

IMPIANTO AGRO-FOTOVOLTAICO "MANIMUZZI" E OPERE CONNESSE

POTENZA IMPIANTO 19.8336 MWp
COMUNI DI COLLEPASSO E CASARANO (LE)

Proponente

EG ETRURIA S.R.L.

VIA DEI PELLEGRINI 22 · 20122 MILANO (MI) · P.IVA: 11769760965 · PEC: egetruria@pec.it

Progettazione

deve-loop

sviluppo sostenibile

DEVE-LOOP S.R.L. UNIPERSONALE

Via ORAZIO, 152
65128 - PESCARA (PE)
P.IVA: 02319140683

ARCH. GIANLUCA
FRANCAVILLA

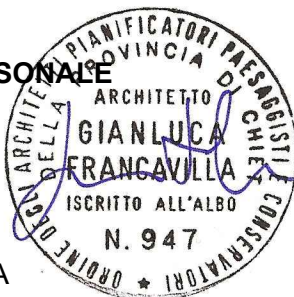

Farenti

FARENTI S.R.L.

Via DON GIUSEPPE CORDA 1576
03030 - SANTOPADRE (FR)
P.IVA: 02604750600

ING. PIERO FARENTI



Coordinamento progettuale

ARCH. GIANLUCA
FRANCAVILLA

DEVE-LOOP S.R.L. UNIPERSONALE
Via ORAZIO, 152 65128 - PESCARA (PE)
P.IVA: 02319140683 · PEC: deve-loop@pec.it

deve-loop
sviluppo sostenibile

Titolo Elaborato

CALCOLI PRELIMINARI DI DIMENSIONAMENTO STRUTTURE

LIVELLO PROGETTAZIONE	CODICE ELABORATO	FILENAME	RIFERIMENTO	DATA	SCALA
PROGETTO DEFINITIVO	REL.10	---	---	04/2022	---

Revisioni

REV.	DATA	DESCRIZIONE	ESEGUITO	VERIFICATO	APPROVATO
0.0	04/2022	PRIMA EMISSIONE	FAR	DEV	ENF

COMUNI DI COLLEPASSO
E CASARANO (LE)
REGIONE PUGLIA



CALCOLI PRELIMINARI STRUTTURE DI SOSTEGNO

Sommario

1. DESCRIZIONE GENERALE	2
2. SCHEMA GEOMETRICO DEI CALCOLI STRUTTURALI	2
3. QUADRO NORMATIVO	5
4. ANALISI DEI CARICHI	6
4. COMBINAZIONI DELLE AZIONI	23
5. AZIONI ALLA BASE DEI PALI	24
6. CALCOLO DELLA LUNGHEZZA DEI PALI	28

1. DESCRIZIONE GENERALE

La struttura meccanica è composta da due telai.

Tre elementi verticali sono fissati nel terreno mediante procedura di speronamento diretto. Sono realizzati in acciaio sezione Ω .

Nella parte superiore di questi, gli elementi di collegamento sono fissi e sostengono le travi principali, e rappresentano degli elementi orizzontali con una sezione tubolare quadrata.

Sulle travi principali, due file di pannelli fotovoltaici in configurazione verticale sono fissate attraverso due diversi tipi di supporto del modulo. Si tratta di traverse secondarie, composte da profilati d'acciaio tubolari rettangolari e sezione Ω .

2. SCHEMA GEOMETRICO DEI CALCOLI STRUTTURALI

Per il calcolo strutturale abbiamo preso in considerazione tre configurazioni principali:

- MODELLO A: $\alpha = 0^\circ$;
- MODELLO B: $\alpha = 30^\circ$;
- MODELLO C: $\alpha = 55^\circ$;

Queste configurazioni sono quelle che generano il massimo stress nella struttura. Sotto è mostrato un diagramma delle dimensioni geometriche per queste configurazioni.

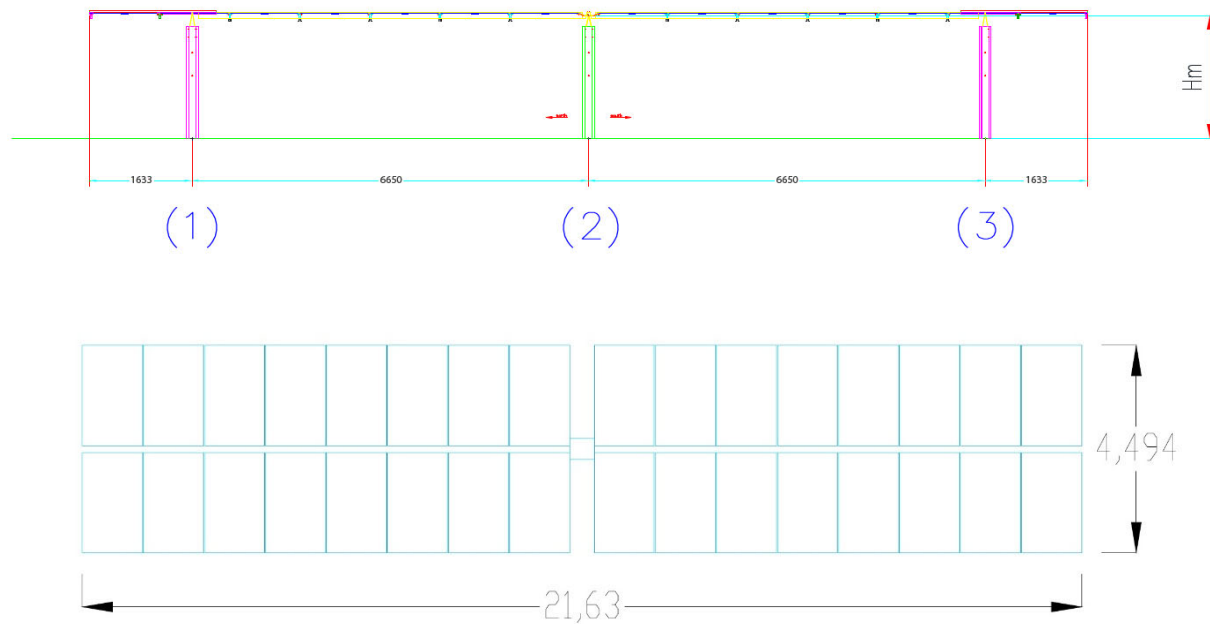

MODEL A - TILT 0°

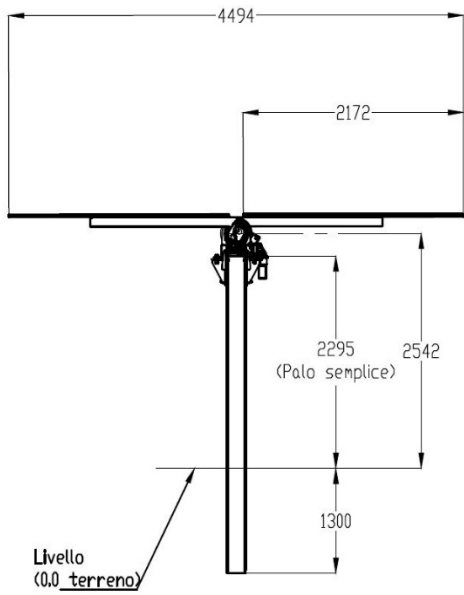

MODEL B - TILT 30°

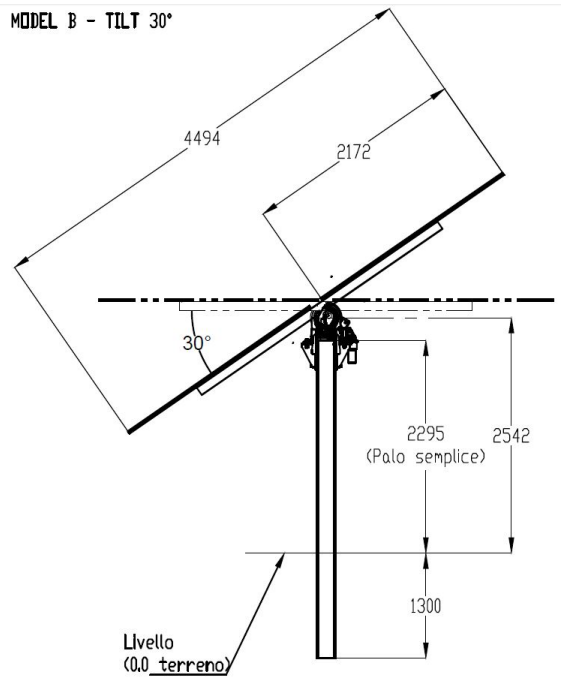

MODEL C - TILT 55°

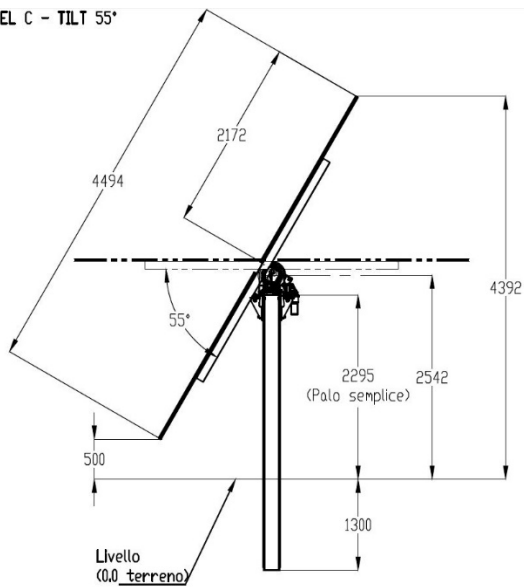

3. QUADRO NORMATIVO

- EUROCODICE 1 – Azioni sulle strutture – Parte 1-4: Azioni in generale – azioni del vento (UNI EN 1991-1-4:2005);
- EUROCODICE 3 – Progettazione delle Strutture in acciaio – Parte 1-1: Regole generali e regole per gli edifici (UNI EN 1993-1-1:2005);
- EUROCODICE 3 – Progettazione delle Strutture in acciaio – Parte 1-8: Progettazione dei collegamenti (UNI EN 1993-1-8:2005);
- D.M. 17 gennaio 2018 – Norme Tecniche per le Costruzioni;
- Legge 2/2/74 n. 64 e DDMM 3/3/1975 – Norme tecniche per la costruzione in zone sismiche.
- Costruzioni in acciaio: Istruzioni per il calcolo, l'esecuzione, il collaudo e la manutenzione. (C.N.R. 10011/85);
- Istruzioni per la valutazione delle Azioni sulle Costruzioni. (C.N.R. 10012/85)

4. ANALISI DEI CARICHI

CARICO PERMANENTE

Structural permanent loads

Central Main Beam- 120x120

L1=	6,000	<i>m - length beeam</i>
pp1=	108,0	<i>N/m - load cross section</i>
n°=	1	
p1.1=	647,9	<i>(N)</i>

Lateral Main Beam- 120x120

L1=	1,388	<i>m - length beeam</i>
pp1=	70,7	<i>N/m - load cross section</i>
n°=	1	
p1.1=	98,2	<i>(N)</i>

Pannel support stand - type P

L2=	0,700	<i>m - length beeam</i>
pp2=	43,6	<i>N/m - load cross section</i>
n°=	1	
p2=	30,5	<i>(N)</i>

Pannel support stand - type S

L2=	1,729	<i>m - length beeam</i>
pp2=	29,8	<i>N/m - load cross section</i>
n°=	1	
p2=	51,6	<i>(N)</i>

KIT's elements for fixing the beam to the central pile

p3=	225,6	<i>(N)</i>
------------	--------------	------------

KIT's elements for fixing the beam to the lateral pile

p3=	279,6	<i>(N)</i>
------------	--------------	------------

Foundation pile - type Ω

L4.1=	2,05	<i>m - preliminary embedment length in to the ground</i>
L4.2=	2,05	<i>m - length above the ground</i>
pp4=	138	<i>N/m - load cross section</i>
n°=	1	
p4=	281,9	<i>(N)</i>

Photovoltaic Modules

A=	1048	<i>(mm)</i>
B=	2108	<i>(mm)</i>
p5=	244	<i>(N)</i>

CARICO DEL VENTO

Il carico del vento è determinato, secondo il D.M. 17 gennaio 2018 – Norme Tecniche per le Costruzioni:

- $\alpha = 0^\circ$: velocità del vento $V = 27$ m/s
- $\alpha \neq 0^\circ$: velocità del vento $V = 15$ m/s

La velocità del vento di base è determinata secondo la Tabella 3.3.I del D.M. 17 gennaio 2018 - Norme Tecniche per le Costruzioni.

Il valore è la caratteristica velocità media del vento di 10 minuti, indipendentemente dalla direzione del vento e dal periodo dell'anno, a 10 m sopra il livello del suolo in terreni aperti con bassa vegetazione come erba e ostacoli isolati, con una probabilità di superare la forza progettata non superiore al 2% in 50 anni.

Il sito fotovoltaico si trova in zona 3 (Puglia), come si evince dalla tabella sottostante

Tab. 3.3.I - Valori dei parametri $v_{b,0}$, a_0 , k_s

Zona	Descrizione	$v_{b,0}$ [m/s]	a_0 [m]	k_s
1	Valle d'Aosta, Piemonte, Lombardia, Trentino Alto Adige, Veneto, Friuli Venezia Giulia (con l'eccezione della provincia di Trieste)	25	1000	0,40
2	Emilia Romagna	25	750	0,45
3	Toscana, Marche, Umbria, Lazio, Abruzzo, Molise, Puglia, Campania, Basilicata, Calabria (esclusa la provincia di Reggio Calabria)	27	500	0,37
4	Sicilia e provincia di Reggio Calabria	28	500	0,36
5	Sardegna (zona a oriente della retta congiungente Capo Teulada con l'Isola di Maddalena)	28	750	0,40
6	Sardegna (zona a occidente della retta congiungente Capo Teulada con l'Isola di Maddalena)	28	500	0,36
7	Liguria	28	1000	0,54
8	Provincia di Trieste	30	1500	0,50
9	Isole (con l'eccezione di Sicilia e Sardegna) e mare aperto	31	500	0,32

Ne consegue che la velocità base del vento $V_{b0} = 27$ m/s

La velocità media del vento è determinata, in accordo con la sezione 3.3.1 del D. M. 17 gennaio 2018, secondo la seguente formula:

$$V_b = C_a \times V_{b0}$$

Dove

$V_{b0} = 27$ m/s per l'inclinazione del tracker = 0°

$V_{b0} = 15 \text{ m/s}$ per l'inclinazione del tracker $\neq 0^\circ$

Ca è il coefficiente di altitudine pari a 1

$$c_s = 1 \quad \text{per } a_i \leq a_0$$
$$c_s = 1 + k_s \left(\frac{a_i}{a_0} - 1 \right) \quad \text{per } a_0 < a_i \leq 1500 \text{ m}$$

Quindi avremo:

$$V_b = 28 \text{ m/s} \quad (\alpha = 0^\circ)$$

$$V_b = 15 \text{ m/s} \quad (\alpha \neq 0^\circ)$$

La velocità di riferimento del vento è calcolata, secondo la sezione 3.3.2 del D.M. 17 gennaio 2018, secondo la seguente formula:

$$V_{br} = C_r \times V_b$$

dove C_r è il coefficiente di ritorno, calcolato, rispetto ad un periodo di ritorno T_r di 25 anni, secondo la seguente formula:

$$c_r = 0,75 \sqrt{1 - 0,20 \cdot \ln \left[-\ln \left(1 - \frac{1}{T_r} \right) \right]} = 0,75 \sqrt{1 - 0,20 \cdot \ln \left[-\ln \left(1 - \frac{1}{25} \right) \right]} = 0,960$$

Quindi avremo:

$$V_{br} = 0,960 \times 27 = 25,92 \text{ m/s} \quad - (\alpha = 0^\circ)$$

$$V_{br} = 1 \times 15 = 15 \text{ m/s} \quad - (\alpha \neq 0^\circ)$$

La pressione cinetica di riferimento è determinata dalla seguente espressione, secondo la sezione 3.3.6 del D.M. 17 gennaio 2018:

$$q_r = \frac{1}{2} \cdot \rho \cdot v_{b,r}^2$$

è la densità dell'aria, calcolata all'altezza di 50 metri sul livello del mare, pari a 1,2 kg/mq

Avremo quindi:

$$q_r = 403 \text{ N/mq} - (\alpha = 0^\circ)$$

$$q_r = 135 \text{ N/mq} - (\alpha \neq 0^\circ)$$

Il coefficiente di esposizione dipende dall'altezza della struttura z sopra il terreno e dalla categoria di esposizione del sito in cui si trova la struttura.

$$c_e(z) = k_t^2 c_t \ln(z/z_0) [7 + c_t \ln(z/z_0)] \quad \text{per } z \geq z_{\min}$$

$$c_e(z) = c_e(z_{\min}) \quad \text{per } z < z_{\min}$$

La classe di rugosità dell'intervento può essere considerata la C, un'area a bassa vegetazione come erba e ostacoli isolati.

Tab. 3.3.III - Classi di rugosità del terreno

Classe di rugosità del terreno	Descrizione
A	Aree urbane in cui almeno il 15% della superficie sia coperto da edifici la cui altezza media superi i 15 m
B	Aree urbane (non di classe A), suburbane, industriali e boschive
C	Aree con ostacoli diffusi (alberi, case, muri, recinzioni,...); aree con rugosità non riconducibile alle classi A, B, D
D	a) Mare e relativa fascia costiera (entro 2 km dalla costa); b) Lago (con larghezza massima pari ad almeno 1 km) e relativa fascia costiera (entro 1 km dalla costa) c) Aree prive di ostacoli o con al più rari ostacoli isolati (aperta campagna, aeroporti, aree agricole, pascoli, zone paludose o sabbiose, superfici innevate o ghiacciate, ...)

L'assegnazione della classe di rugosità non dipende dalla conformazione orografica e topografica del terreno. Si può assumere che il sito appartenga alla Classe A o B, purché la costruzione si trovi nell'area relativa per non meno di 1 km e comunque per non meno di 20 volte l'altezza della costruzione, per tutti i settori di provenienza del vento ampi almeno 30°. Si deve assumere che il sito appartenga alla Classe D, qualora la costruzione sorga nelle aree indicate con le lettere a) o b), oppure entro un raggio di 1 km da essa vi sia un settore ampio 30°, dove il 90% del terreno sia del tipo indicato con la lettera c). Laddove sussistano dubbi sulla scelta della classe di rugosità, si deve assegnare la classe più sfavorevole (l'azione del vento è in genere minima in Classe A e massima in Classe D).

ZONE 1,2,3,4,5						
	costa	10 km	30 km	500m	750m	
A	--	IV	IV	V	V	V
B	--	III	III	IV	IV	IV
C	--	*	III	III	IV	IV
D	I	II	II	II	III	**
* Categoria II in zona 1,2,3,4 Categoria III in zona 5						
** Categoria III in zona 2,3,4,5 Categoria IV in zona 1						

I parametri per il calcolo di c_e , per il sito con categoria di esposizione III e con un fattore topografico uguale a $ct = 1$, sono riportati nella tabella seguente:

Tab. 3.3.II - Parametri per la definizione del coefficiente di esposizione

Categoria di esposizione del sito	K_t	z_0 [m]	z_{min} [m]
I	0,17	0,01	2
II	0,19	0,05	4
III	0,20	0,10	5
IV	0,22	0,30	8
V	0,23	0,70	12

Pertanto, il valore del coefficiente di esposizione è

$$c_e = k_r^2 c_t \ln\left(\frac{z}{z_0}\right) \left[7 + c_t \ln\left(\frac{z}{z_0}\right)\right] = 0,20^2 \ln\left(\frac{5}{0,1}\right) \left[7 + \ln\left(\frac{5}{0,1}\right)\right] = 1,708$$

Il coefficiente dinamico C_d è determinato in riferimento al fattore $C_s C_d$.

I fattori strutturali C_s e C_d dovrebbero tenere conto dell'effetto sulle azioni del vento derivante dal verificarsi non simultaneo di picchi di pressione del vento sulla superficie insieme all'effetto delle vibrazioni della struttura dovute alla turbolenza. Il fattore strutturale $C_s C_d$ può essere separato in un fattore dimensionale (c_s) e un fattore dinamico (c_d), in base al capitolo 6.3.1.

Il calcolo del fattore strutturale $C_s C_d$ è stato eseguito mediante l'uso di un foglio Excel, come di seguito descritto.

Calculation of the structural factor $c_s \cdot c_d$ - for upwind ($\alpha=0^\circ$)

Geometrical and mechanical characteristics		
$z_s =$	4,450	III = Terrain category (m) reference height of the structure
$z_0 =$	0,1	(m)
$z_{eq} =$	5	(m)
$V_m =$	26,89	(m/s) mean wind velocity
$\rho =$	1,2070	(kg/m ³) air density
$C_f =$	0,20	force coefficient for the structure (Section 7)
$C_g =$	1	orography factor
Massa del 1° modo	65	(Kg) is the equivalent mass per unit length according to EN 1991-1-4 § F.4.
$I_{vr} =$	0,256	turbulence intensity

Wind turbulence		
$L(z) = L_0 \left(\frac{z}{z_0} \right)^{0,167}$ for $z > z_{eq}$	38,742	Turbulent length scale
$L(z) = L_0 \left(\frac{z}{z_{eq}} \right)^{0,167}$ for $z < z_{eq}$		
$L_t =$	300	m
$z_t =$	200	m
$S_w(z) = \frac{n \cdot S_w(z_n)}{z_n^2} = \frac{6,8 \cdot (z_n/n)^{-5,75}}{(1+10,2 \cdot (z_n/n)^{-1,25})^2}$	0,0383	non dimensional power spectral density
$T =$	0,21	Fundamental period of the structure
$n =$	4,76	natural frequency of the structure in Hz
$f_z(z, n) = \frac{n \cdot L(z)}{V_m(z)}$	6,861	non dimensionale frequency

Calculation of the background factor B - procedure 1 - Annex B		
$B^2 = \frac{1}{1 + 0,9 \cdot \left(\frac{b+h}{L(z_s)} \right)^{0,63}}$	0,636	background factor
$b =$	14,432	(m) length tracker - see fig.6.1
$h =$	4,432	(m) width tracker - see fig.6.1

Calculation of the peak factor k_p		
$k_p = \sqrt{2 \cdot \ln(v \cdot T)} = \frac{0,6}{\sqrt{2 \cdot \ln(v \cdot T)}}$	3,683	
$T =$	600	(sec) is the averaging time for the mean wind velocity
$v = n_{1,4} \sqrt{\frac{R^2}{B^2 + R^2}}$	0,796	is the up-crossing frequency
$R^2 = \frac{\sigma^2}{2 \cdot \delta} \cdot S_w(z_{1,4}, n_{1,4}) \cdot R_p(\eta_b) \cdot R_p(\eta_s)$	0,018	Resonance response factor
$\eta_b = \frac{4,6 \cdot h}{L(z_s)} \cdot f_z(z_s, n_{1,4})$	3,610	
$\eta_s = \frac{4,6 \cdot b}{L(z_s)} \cdot f_z(z_s, n_{1,4})$	11,755	
$R_p = \frac{1}{\eta_b} \cdot \frac{1}{2 \cdot \eta_s^2} \cdot (1 - \theta^{-2 \eta_b})$	0,239	
$R_s = \frac{1}{\eta_b} \cdot \frac{1}{2 \cdot \eta_s^2} \cdot (1 - \theta^{-2 \eta_s})$	0,081	

Calculation logarithmic decrement of damping		
$\delta_s =$	0,05	logarithmic decrement of structural damping - Table F.2
$\delta_a = \frac{C_d \cdot \rho \cdot b \cdot V_m(z_s)}{2 \cdot n_1 \cdot m_b}$	0,15	logarithmic decrement of aerodynamic damping
$\delta_{sp} =$	0	when no special device is used.
$\delta = \delta_s + \delta_a + \delta_{sp}$	0,201	logarithmic decrement of damping

Structural factor $c_d \cdot c_s$		
$c_s \cdot c_d = \frac{1 + 2 \cdot k_p \cdot I_{vr}(z_s) \cdot \sqrt{B^2 + R^2}}{1 + 7 \cdot I_{vr}(z_s)}$	0,905	

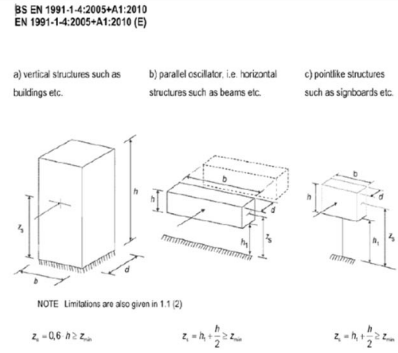

6.3.1 Structural factor c_s
 (1) The detailed procedure for calculating the structural factor c_s is given in Expression (6.1). This procedure can only be used if the conditions given in 6.3.1 (2) apply.

$$c_s = \frac{1 + 2 \cdot k_p \cdot I_{vr}(z_s) \cdot \sqrt{B^2 + R^2}}{1 + 7 \cdot I_{vr}(z_s)}$$
 (6.1)
 where:
 z_s is the reference height for determining the structural factor, see Figure 6.1. For structures where Figure 6.1 does not apply z_s may be set equal to h , the height of the structure.
 k_p is the peak factor defined as the ratio of the maximum value of the fluctuating part of the response to its standard deviation.
 I_{vr} is the turbulence intensity defined in 4.4.
 B^2 is the background factor, allowing for turbulence in resonance with the vibration mode.
 R^2 is the resonance response factor, allowing for turbulence in resonance with the vibration mode.
 NOTE 1: The side factor c_d takes into account the reduction effect on the wind action due to the non-simultaneity of occurrence of the peak wind pressures on the surface and may be obtained from Expression (6.2).

$$c_d = \frac{1 - F \cdot I_{vr}(z_s) \cdot \sqrt{B^2 + R^2}}{1 + F \cdot I_{vr}(z_s)}$$
 (6.2)
 NOTE 2: The side factor c_d takes into account the increasing effect from vibrations due to turbulence in resonance with the structure and may be obtained from Expression (6.3).

$$c_d = \frac{1 - 2 \cdot A_s \cdot I_{vr}(z_s) \cdot \sqrt{B^2 + R^2}}{1 + F \cdot I_{vr}(z_s) \cdot \sqrt{B^2 + R^2}}$$
 (6.3)
 NOTE 3: The procedure to be used to determine k_p , B and R may be given in the National Annex. A modification procedure is given in Annex B. An alternative procedure is given in Annex C. As an indication to the user the differences in c_d using Annex C compared to Annex B does not exceed approximately 2%.
 (2) Expression (6.1) shall only be used if all of the following requirements are met:
 - the structure corresponds to one of the general shapes shown in Figure 6.1.
 - only the along-wind vibration in the fundamental mode is significant and this mode shape has a constant sign.
 NOTE: The contribution to the response from the second or higher alongwind modes is negligible.

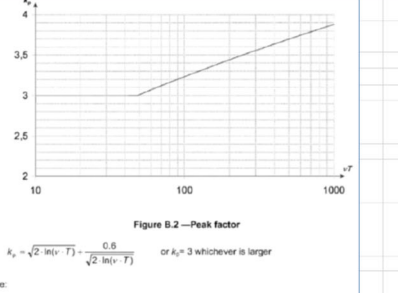

Table F.2 — Approximate values of logarithmic decrement of structural damping in the fundamental mode, δ_s

Structural type	structural damping δ_s
reinforced concrete buildings	0.10
steel buildings	0.05
mixed structures concrete + steel	0.08
reinforced concrete towers and chimneys	0.03
unlined welded steel stacks without external thermal insulation	0.012
unlined welded steel stack with external thermal insulation*	0.020
steel stack with one liner with external thermal insulation*	1) $h/b \leq 18$: 0.020
	2) $20 < h/b \leq 24$: 0.040
	$h/b \geq 28$: 0.014
steel stack with two or more liners with external thermal insulation*	$h/b \leq 18$: 0.020
	$20 < h/b \leq 24$: 0.040
	$h/b \geq 28$: 0.025
steel stack with internal brick liner	0.070
steel stack with internal gunite	0.030
coupled stacks without liner	0.015
guyed steel stack without liner	0.04
steel bridges	0.02
lattice steel towers	0.03
high resistance bolts	0.05
ordinary bolts	0.06
composite bridges	0.04
concrete bridges	0.04
prestressed without cracks	0.10
with cracks	0.06 - 0.12
timber bridges	0.06 - 0.12
aluminum alloys	0.02
bridges, glass or fibre reinforced plastic	0.04 - 0.08
cables	0.006
parallel cables	0.020
spiral cables	0.020

Calculation of the structural factor $c_s \cdot c_d$ - for downwind ($\alpha=0^\circ$)

Geometrical and mechanical characteristics		
z_0	III	= Terrain category
z_0	4,450	(m) reference height of the structure
z_{0m}	0,1	(m)
z_{min}	5	(m)
V_m	26,89	(m/s) mean wind velocity
ρ	1,2070	(kg/m ³) air density
C_f	0,50	force coefficient for the structure (Section 7)
C_{g1}	1	orography factor
Massa del 1° modo	65	(Kg) is the equivalent mass per unit length according to EN 1991-1-4 § F.4.
I_w	0,256	turbulence intensity

Wind turbulence		
$L(z) = L_0 \left(\frac{z}{z_0} \right)^{0,167}$ for $z > z_{min}$	38,742	Turbulent length scale
$L(z) = L(z_{min})$ for $z < z_{min}$		
$L1$	300	m
$z1$	200	m
$S_s(z, n) = \frac{n \cdot S_s(z, n)}{\sigma_s^2} = \frac{0,88 \cdot (z/n)^{0,167}}{(1 + 10,2 \cdot (z/n)^{0,167})^{0,33}}$	0,0383	non dimensional power spectral density
T	0,21	Fundamental period of the structure
n	4,76	natural frequency of the structure in Hz
$f_s(z, n) = \frac{n \cdot L(z)}{V_m(z)}$	6,861	non dimensionale frequency

Calculation of the background factor B - procedure 1 - Annex B		
$B^2 = \frac{1}{1 + 0,9 \cdot \left(\frac{b+h}{L(z_s)} \right)^{0,68}}$	0,636	background factor
b	14,432	(m) length tracker - see fig.6.1
h	4,432	(m) width tracker - see fig.6.1

Calculation of the peak factor Kp		
$k_p = \sqrt{2 \cdot \ln(v \cdot T)} + \frac{0,6}{\sqrt{2 \cdot \ln(v \cdot T)}}$	3,582	
T	600	(sec) is the averaging time for the mean wind velocity
$v = n_s \cdot \sqrt{\frac{R^2}{B^2 + R^2}}$	0,550	is the up-crossing frequency
$R^2 = \frac{\pi^2}{2 \cdot \delta} \cdot S_s(z_s, n_s) \cdot R_s(\eta_s) \cdot R_b(\eta_b)$	0,009	Resonance response factor
$\eta_s = \frac{4,6 \cdot h}{L(z_s)} \cdot f_s(z_s, n_s)$	3,610	
$\eta_b = \frac{4,6 \cdot b}{L(z_s)} \cdot f_s(z_s, n_s)$	11,755	
$R_s = \frac{1}{\eta_s} \cdot \frac{1}{2 \cdot \eta_s} \cdot (1 - \theta^{-2 \eta_s})$	0,239	
$R_b = \frac{1}{\eta_b} \cdot \frac{1}{2 \cdot \eta_b} \cdot (1 - \theta^{-2 \eta_b})$	0,081	

Calculation logarithmic decrement of damping		
$\delta_s = 0,05$	0,05	logarithmic decrement of structural damping - Table F.2
$\delta_a = \frac{C_f \cdot \rho \cdot b \cdot V_m(z_s)}{2 \cdot n_s \cdot m_s}$	0,38	logarithmic decrement of aerodynamic damping
$\delta_0 = 0$	0	when no special device is used.
$\delta = \delta_s + \delta_a + \delta_0$	0,428	logarithmic decrement of damping

Structural factor cd^*c_s		
$c_s \cdot c_d = \frac{1 + 2 \cdot k_p \cdot I_w(z_s) \cdot \sqrt{B^2 + R^2}}{1 + 7 \cdot I_w(z_s)}$	0,886	

BS EN 1991-1-4:2005+A1:2010
 EN 1991-1-4:2005+A1:2010 (E)

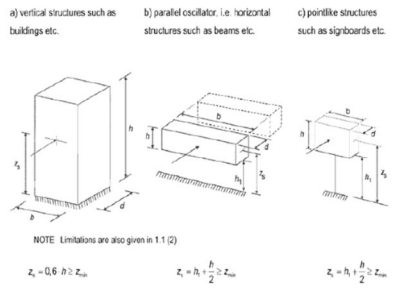

6.3.1 Structural factor $c_s \cdot c_d$

(1) The detailed procedure for calculating the structural factor $c_s \cdot c_d$ is given in Expression (6-1). This procedure can only be used if the conditions given in 6.3.1 (2) apply.

$$c_s \cdot c_d = \frac{1 + 2 \cdot k_p \cdot I_w(z_s) \cdot \sqrt{B^2 + R^2}}{1 + 7 \cdot I_w(z_s)} \quad (6.1)$$

where:

- z_s is the reference height for determining the structural factor. See Figure 6.1. For structures where Figure 6.1 does not apply z_s may be set equal to h , the height of the structure.
- k_p is the peak factor defined as the ratio of the maximum value of the fluctuating part of the response to its standard deviation
- I_w is the turbulence intensity defined in 4.4
- B^2 is the background factor, allowing for the lack of full correlation of the pressure on the structure surface
- R^2 is the resonance response factor, allowing for turbulence in resonance with the vibration mode

NOTE 1. The site factor c_s takes into account the reduction effect on the wind action due to the non-simultaneity of occurrence of the peak wind pressures on the surface and may be obtained from Expression 6.3.2

$$c_s = \frac{1 - 7 \cdot I_w(z_s) \cdot \sqrt{B^2 + R^2}}{1 + 7 \cdot I_w(z_s)} \quad (6.2)$$

NOTE 2. The dynamic factor c_d takes into account the increase in the wind action due to turbulence in resonance with the structure and may be obtained from Expression 6.3.3

$$c_d = \frac{1 + 2 \cdot k_p \cdot I_w(z_s) \cdot \sqrt{B^2 + R^2}}{1 + 7 \cdot I_w(z_s)} \quad (6.3)$$

NOTE 3. The procedure to be used to determine k_p , B and R may be given in the National Annex. A recommended procedure is given in Annex B. An alternative procedure is given in Annex C. As an exception to the usual the reference to c_s using Annex C compared to Annex B does not exceed approximately 5%.

GPF Expression (6.1) shall only be used if all of the following requirements are met:

- the structure corresponds to one of the general shapes shown in Figure 6.1
- only the along-wind vibration in the fundamental mode is significant, and this mode shape has a constant sign.

NOTE: The contribution to the response from the second or higher along-wind vibration modes is negligible.

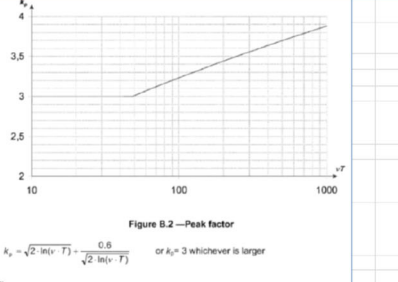

Table F.2 — Approximate values of logarithmic decrement of structural damping in the fundamental mode, δ_s

Structural type	structural damping, δ_s
reinforced concrete buildings	0.10
steel buildings	0.05
mixed structures concrete + steel	0.08
reinforced concrete towers and chimneys	0.03
Unstayed welded steel stacks without external thermal insulation	0.012
unstayed welded steel stacks with external thermal insulation	0.020
steel stack with one liner with external thermal insulation*	$\eta/b = 18$ 0.020
	$20 \leq \eta/b \leq 24$ 0.040
	$\eta/b \geq 26$ 0.014
steel stack with two or more liners with external thermal insulation*	$\eta/b = 18$ 0.020
	$20 \leq \eta/b \leq 24$ 0.040
	$\eta/b \geq 26$ 0.028
steel stack with internal brick liner	0.070
steel stack with internal gurnite	0.030
coupled stacks without liner	0.016
guyed steel stack without liner	0.04
steel bridges + lattice steel towers	welded 0.02
	high resistance bolts 0.03
	ordinary bolts 0.05
composite bridges	0.04
concrete bridges	unstressed without cracks 0.04
	with cracks 0.10
Timber bridges	0.06 - 0.12
Bridges, aluminum alloys	0.02
Bridges, glass or fibre reinforced plastic	0.04 - 0.05
cables	parallel cables 0.006
	spiral cables 0.020

Calculation of the structural factor $c_s \cdot c_d$ - for upwind ($\alpha=30^\circ$)

Geometrical and mechanical characteristics

Z_s	4,450	Terrain category III
Z_0	0,1	(m) reference height of the structure
Z_{min}	5	(m)
V_m	15	(m/s) mean wind velocity
ρ	1,2070	(Kg/m ³) air density
C_F	1,200	force coefficient for the structure (Section 7)
C_{pe}	1	orography factor
Massa del 1° modo	65	(Kg) is the equivalent mass per unit length according to EN 1991-1-4 § F.4.
I_w	0,256	turbulence intensity

$I_w(z) = \frac{0,16}{z} \left(\frac{z}{z_0} \right)^{0,16}$ for $z \geq z_{min}$
 $I_w(z) = \frac{0,16}{z_{min}}$ for $z < z_{min}$ (4.7)
 where:
 A. is the turbulence factor. The value of A_s may be given in the National Annex. The recommended value for A_s is 1,0.
 C. is the orography factor as described in 4.3.3
 z₀ is the roughness length, given in Table 4.1

Wind turbulence

$L(z)$	38,742	Turbulent length scale
L_t	300	m
L_z	200	m
$S_w(z)$	0,0263	non dimensional power spectral density
T	0,21	Fundamental period of the structure
n	4,76	natural frequency of the structure in Hz
$f_s(z, n)$	12,299	non dimensionale frequency

Calculation of the background factor B - procedure 1 - Annex B

$B^2 = \frac{1}{1 + 0,9 \cdot \left(\frac{b+h}{L(z_s)} \right)^{0,65}}$	0,636	background factor
b	14,432	(m) length tracker - see fig.6.1
h	4,432	(m) width tracker - see fig.6.1

Calculation of the peak factor K_p

$k_p = \sqrt{2 \cdot \ln(v \cdot T)} + \frac{0,6}{\sqrt{2 \cdot \ln(v \cdot T)}}$	3,335	
T	600	(sec) is the averaging time for the mean wind velocity
$v = n_1 \cdot \sqrt{\frac{R^2}{B^2 + R^2}}$	0,234	is the up-crossing frequency
$R^2 = \frac{z^2}{2 \cdot \delta} \cdot S_w(z_s, n_1) \cdot R_y(\eta_s) \cdot R_y(\eta_b)$	0,002	Resonance response factor
$\eta_b = \frac{4,6 \cdot h}{L(z_s)} \cdot f_s(z_s, n_1)$	6,472	
$\eta_s = \frac{4,6 \cdot b}{L(z_s)} \cdot f_s(z_s, n_1)$	21,075	
$R_y = \frac{1}{\eta_b} \cdot \frac{1}{2 \cdot \eta_s^2} \cdot (1 - \theta^{-2\eta_b})$	0,143	
$R_s = \frac{1}{\eta_s} \cdot \frac{1}{2 \cdot \eta_b^2} \cdot (1 - \theta^{-2\eta_s})$	0,046	

Calculation logarithmic decrement of damping

δ_s	0,05	logarithmic decrement of structural damping - Table F.2
$\delta_a = \frac{c_1 \cdot \rho \cdot b \cdot v_m(z_s)}{2 \cdot n_1 \cdot m_b}$	0,51	logarithmic decrement of aerodynamic damping
δ_{c1}	0	when no special device is used.
$\delta = \delta_s + \delta_a + \delta_{c1}$	0,557	logarithmic decrement of demping

Structural factor $c_d \cdot c_s$

$c_d \cdot c_s = \frac{1 + 2 \cdot k_p \cdot I_w(z_s) \cdot \sqrt{B^2 + R^2}}{1 + 7 \cdot I_w(z_s)}$	0,847	
--	-------	--

BS EN 1991-1-4:2005+A1:2010
 EN 1991-1-4:2005+A1:2010 (E)

- a) vertical structures such as buildings etc.
- b) parallel oscillator, i.e. horizontal structures such as beams etc.
- c) porifike structures such as signboards etc.

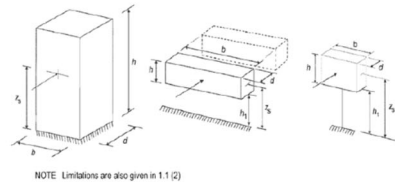

NOTE: Limitations are also given in 1.1 (2)

$$z_s = 0,6 \cdot h \geq z_{min} \quad z_s = h_1 + \frac{h}{2} \geq z_{min} \quad z_s = h_1 + \frac{h}{2} \geq z_{min}$$

6.3.1 Structural factor $c_d \cdot c_s$

(1) The detailed procedure for calculating the structural factor $c_d \cdot c_s$ is given in Expression (6.1). This procedure can only be used if the conditions given in 6.3.1 (2) apply.

$$c_d \cdot c_s = \frac{1 + 2 \cdot k_p \cdot I_w(z_s) \cdot \sqrt{B^2 + R^2}}{1 + 7 \cdot I_w(z_s)} \quad (6.1)$$

where:

- z_s is the reference height for determining the structural factor, see Figure 6.1. For structures where Figure 6.1 does not apply z_s may be set equal to h , the height of the structure.
- k_p is the peak factor defined as the ratio of the maximum value of the fluctuating part of the response to its standard deviation.
- I_w is the turbulence intensity defined in 4.4.
- B^2 is the background factor, allowing for the lack of full correlation of the pressure on the structure surface.
- R^2 is the resonance response factor, allowing for turbulence in resonance with the vibration mode.

NOTE 1: The size factor c_s takes into account the resonance effect on the wind action due to the non-uniformity of the wind pressure on the surface and may be obtained from Expression (6.2).

$$c_s = \frac{1 + 7 \cdot I_w(z_s) \cdot \sqrt{B^2}}{1 + 7 \cdot I_w(z_s)} \quad (6.2)$$

NOTE 2: The dynamic factor c_d takes into account the increasing effect from vibrations due to turbulence in resonance with the structure and may be obtained from Expression (6.3).

$$c_d = \frac{1 + 2 \cdot k_p \cdot I_w(z_s) \cdot \sqrt{B^2 + R^2}}{1 + 7 \cdot I_w(z_s) \cdot \sqrt{B^2}} \quad (6.3)$$

NOTE 3: The procedure to be used to determine k_p , B and R may be given in the National Annex. A recommended procedure is given in Annex B. An alternative procedure is given in Annex C. As an indication to the user, the difference in the values of $c_d \cdot c_s$ compared to Annex B does not exceed approximately 5%.

NOTE: Expression (6.1) shall only be used if all of the following requirements are met:

- the structure corresponds to one of the general shapes shown in Figure 6.1.
- only the along-wind vibration in the fundamental mode is significant, and this mode shape has a constant sign.
- NOTE: The contribution to the response from the second or higher along-wind vibration modes is negligible.

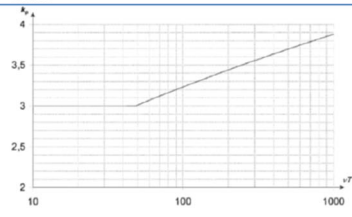

Figure B.2 — Peak factor

$$k_p = \sqrt{2 \cdot \ln(v \cdot T)} + \frac{0,6}{\sqrt{2 \cdot \ln(v \cdot T)}} \quad \text{or} \quad k_p = 3 \quad \text{whichever is larger}$$

where:

v is the up-crossing frequency given in (4)

T is the averaging time for the mean wind velocity, $T = 600$ seconds.

Table F.2 — Approximate values of logarithmic decrement of structural damping in the fundamental mode, δ_s

Structural type	Structural damping, δ_s
reinforced concrete buildings	0,10
steel buildings	0,05
mixed structures concrete – steel	0,08
reinforced concrete towers and chimneys	0,03
unlined welded steel stacks without external thermal insulation	0,012
unlined welded steel stack with external thermal insulation	0,020
steel stack with one liner with external thermal insulation*	$h/b < 18$ 0,020 20: $h/b < 24$ 0,040 $h/b \geq 26$ 0,014
steel stack with two or more liners with external thermal insulation*	$h/b < 18$ 0,020 20: $h/b < 24$ 0,040 $h/b \geq 26$ 0,025
steel stack with internal brick liner	0,070
steel stack with internal gunite	0,030
coupled stacks without liner	0,015
guyed steel stack without liner	0,04
steel	welded 0,02
bridges	high resistance bolts 0,03
lattice steel towers	ordinary bolts 0,05
composite bridges	0,04
concrete bridges	prestressed without cracks 0,04 with cracks 0,10
Timber bridges	0,06 - 0,12
Bridges, aluminum alloys	0,02
Bridges, glass or fibre reinforced plastic	0,04 - 0,08
cables	parallel cables 0,006 spiral cables 0,020

Calculation of the structural factor $c_s \cdot c_d$ - for downwind ($\alpha=30^\circ$)

Geometrical and mechanical characteristics		
III	= Terrain category	
$z_s =$	4,450	(m) reference height of the structure
$z_0 =$	0,1	(m)
$z_{0,m} =$	5	(m)
$V_m =$	15	(m/s) mean wind velocity
$\rho =$	1,2070	(Kg/m ³) air density
$C_f =$	1,800	force coefficient for the structure (Section 7)
$C_{g1} =$	1	orography factor
Massa del 1° modo	65	(Kg) is the equivalent mass per unit length according to EN 1991-1-4 § F.4.
$I_w =$	0,256	turbulence intensity

Wind turbulence		
$L(z) = k_z \left(\frac{z}{z_0} \right)^{\alpha}$ for $z > z_{0,m}$	38,742	Turbulent length scale
$L(z) = 4z_{0,m}$ for $z < z_{0,m}$		
$L_t =$	300	m
$z_t =$	200	m
$S_z(z, n) = \frac{n \cdot S_z(z, n)}{v^2} = \frac{6,8 \cdot I_w(z)}{(1 + 10,2 \cdot I_w(z))^{1,3}}$	0,0263	non dimensional power spectral density
$T =$	0,21	Fundamental period of the structure
$n =$	4,76	natural frequency of the structure in Hz
$f_z(z, n) = \frac{n \cdot L(z)}{V_m(z)}$	12,299	non dimensionale frequency

Calculation of the background factor B - procedure 1 - Annex B		
$B^2 = \frac{1}{1 + 0,9 \cdot \left(\frac{b+h}{L(z_s)} \right)^{0,63}}$	0,636	background factor
$b =$	14,432	(m) length tracker - see fig.6.1
$h =$	4,432	(m) width tracker - see fig.6.1

Calculation of the peak factor k_p		
$k_p = \sqrt{2 \cdot \ln(v \cdot T)} + \frac{0,6}{\sqrt{2 \cdot \ln(v \cdot T)}}$	3,279	
$T =$	600	(sec) is the averaging time for the mean wind velocity
$v = n_{1,4} \sqrt{\frac{R^2}{B^2 + R^2}}$	0,194	is the up-crossing frequency
$R^2 = \frac{\pi^2}{2 \cdot \delta} \cdot S_z(z_s, n_{1,4}) \cdot R_y(\eta_s) \cdot R_y(\eta_b)$	0,001	Resonance response factor
$\eta_b = \frac{4,6 \cdot h}{L(z_s)} \cdot f_z(z_s, n_{1,4})$	6,472	
$\eta_s = \frac{4,6 \cdot b}{L(z_s)} \cdot f_z(z_s, n_{1,4})$	21,075	
$R_s = \frac{1}{\eta_s} \cdot \frac{1}{2 \cdot \eta_s^2} (1 - \theta^{-2\eta_s})$	0,143	
$R_b = \frac{1}{\eta_b} \cdot \frac{1}{2 \cdot \eta_b^2} (1 - \theta^{-2\eta_b})$	0,046	

Calculation logarithmic decrement of damping		
$S_d =$	0,05	logarithmic decrement of structural damping - Table F.2
$\delta_a = \frac{c_d \cdot \rho \cdot b \cdot V_m(z_s)}{2 \cdot n_1 \cdot m_b}$	0,76	logarithmic decrement of aerodynamic damping
$\delta_{07} =$	0	when no special device is used.
$\delta = \delta_s + \delta_a + \delta_{07}$	0,810	logarithmic decrement of damping

Structural factor $c_d \cdot c_s$		
$c_d \cdot c_s = \frac{1 + 2 \cdot k_p \cdot I_w(z_s) \cdot \sqrt{B^2 + R^2}}{1 + 7 \cdot I_w(z_s)}$	0,838	

BS EN 1991-1-4:2005+A1:2010
 EN 1991-1-4:2005+A1:2010 (E)

- a) vertical structures such as buildings etc.
- b) parallel oscillator i.e. horizontal structures such as beams etc.
- c) parallel structures such as signboards etc.

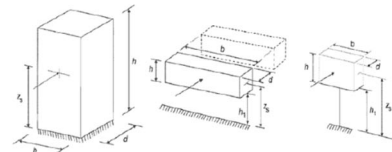

NOTE: Limitations are also given in 1.1 (2)

$$z_1 = 0,6 \cdot b \geq z_{0,m} \quad z_2 = h_1 + \frac{h}{2} \geq z_{0,m} \quad z_3 = h_1 + \frac{h}{2} \geq z_{0,m}$$

6.3.1 Structural factor $c_s \cdot c_d$

(1) The detailed procedure for calculating the structural factor $c_s \cdot c_d$ is given in Expression (6.1). This procedure can only be used if the conditions given in 6.3.1 (2) apply.

$$c_s \cdot c_d = \frac{1 + 2 \cdot k_p \cdot I_w(z_s) \cdot \sqrt{B^2 + R^2}}{1 + 7 \cdot I_w(z_s)} \quad (6.1)$$

where:

- z_s is the reference height for determining the structural factor, see Figure 6.1. For structures where Figure 6.1 does not apply z_s may be set equal to h_s , the height of the structure.
- k_p is the peak factor defined as the ratio of the maximum value of the fluctuating part of the response to its standard deviation
- L is the turbulence intensity defined in 4.4
- R^2 is the background factor, allowing for the lack of full correlation of the pressure on the structure surface
- R^2 is the resonance response factor, allowing for turbulence in resonance with the vibration mode

NOTE 1: The peak factor k_p takes into account the reduction effect on the wind action due to the non-stationary and non-uniformity of the peak wind pressures on the surface and may be obtained from Expression (6.3).

$$k_p = 1 + 7 \cdot I_w(z_s) \cdot \sqrt{B^2 + R^2} \quad (6.2)$$

$$k_p = 1 + 2 \cdot k_p \cdot I_w(z_s) \cdot \sqrt{B^2 + R^2} \quad (6.3)$$

NOTE 2: The dynamic factor c_d takes into account the increasing effect from vibrations due to turbulence in resonance with the structure and may be obtained from Expression (6.1).

NOTE 3: This procedure to be used to determine $c_s \cdot c_d$ and R^2 may be given in the National Annex. A recommended procedure is given in Annex B. An alternative procedure is given in Annex C. As an indication to the users, the differences in $c_s \cdot c_d$ using Annex C compared to Annex B does not exceed approximately 20%.

NOTE 4: Expression (6.1) shall only be used if all of the following requirements are met:

- the structure corresponds to one of the general shapes shown in Figure 6.1.
- only the along-wind vibration in the fundamental mode is significant, and this mode shape has a constant sign.

NOTE: The contribution to the response from the second or higher elongated vibration modes is negligible.

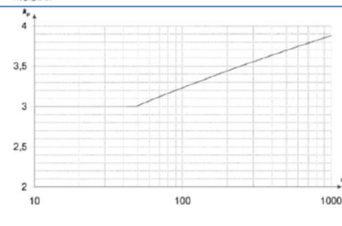

Figure B.2 - Peak factor
 $k_p = \sqrt{2 \cdot \ln(v \cdot T)} + \frac{0,6}{\sqrt{2 \cdot \ln(v \cdot T)}}$ or $k_p = 3$ whichever is larger

Table F.2 - Approximate values of logarithmic decrement of structural damping in the fundamental mode, δ_s

Structural type	Structural damping δ_s
reinforced concrete buildings	0.10
steel buildings	0.05
mixed structures concrete + steel	0.08
reinforced concrete towers and chimneys	0.03
uninsulated welded steel stacks without external thermal insulation	0.012
uninsulated welded steel stack with external thermal insulation	0.020
steel stack with one liner with external thermal insulation	$h/b < 18$ 0.040 $20 \leq h/b \leq 24$ 0.040 $h/b \geq 25$ 0.014
steel stack with two or more liners with external thermal insulation*	$h/b < 18$ 0.020 $20 \leq h/b \leq 24$ 0.040 $h/b \geq 25$ 0.025
steel stack with internal brick liner	0.070
steel stack with internal granite	0.030
coupled stacks without liner	0.015
joined steel stack without liner	0.04
steel + lattice steel towers	welded 0.02
	high resistance bolts 0.03
composite bridges	ordinary bolts 0.05
	0.04
concrete bridges	prestressed without cracks 0.04
	with cracks 0.10
Timber bridges	0.06 - 0.12
Bridges, aluminum alloys	0.02
Bridges, glass or fibre reinforced plastic	0.04 - 0.08
cables	parallel cables 0.066
	spiral cables 0.020

Calculation of the structural factor $c_s \cdot c_d$ - for upwind ($\alpha=55^\circ$)

1.41	III	= Terrain category
$z_s =$	4,450	(m) reference height of the structure
$z_0 =$	0,1	(m)
$z_{eq} =$	5	(m)
$V_m =$	15	(m/s) mean wind velocity
$\rho =$	1,2070	(Kg/m ³) air density
$C_f =$	1,410	force coefficient for the structure (Section 7)
$C_{g1} =$	1	orography factor
Massa del 1° modo	65	(Kg) is the equivalent mass per unit length according to EN 1991-1-4 § F.4.
$I_w =$	0,256	turbulence intensity

Wind turbulence

$L(z) = k_s \left(\frac{z}{z_0} \right)^{0,16}$ for $z > z_{eq}$	38,742	Turbulent length scale
$L(z) = 4z_{eq}$ for $z < z_{eq}$		
$L_t =$	300	m
$z_t =$	200	m
$S_z(z) = \frac{n \cdot S_z(z_n)}{z^2} = \frac{6,8 \cdot (z_n)^{-2}}{(1 + 10,2 \cdot (z_n)^{0,16})^2}$	0,0263	non dimensional power spectral density
$T =$	0,21	Fundamental period of the structure
$n =$	4,76	natural frequency of the structure in Hz
$f_z(z, n) = \frac{n \cdot L(z)}{V_m(z)}$	12,299	non dimensionale frequency

Calculation of the background factor B - procedure 1 - Annex B

$B^2 = \frac{1}{1 + 0,9 \cdot \left(\frac{b+h}{L(z_s)} \right)^{0,63}}$	0,636	background factor
$b =$	14,432	(m) length tracker - see fig.6.1
$h =$	4,432	(m) width tracker - see fig.6.1

Calculation of the peak factor k_p

$k_p = \sqrt{2 \cdot \ln(v \cdot T)} + \frac{0,6}{\sqrt{2 \cdot \ln(v \cdot T)}}$	3,313	
$T =$	600	(sec) is the averaging time for the mean wind velocity
$v = n_{1,1} \sqrt{\frac{R^2}{B^2} + R^2}$	0,217	is the up-crossing frequency
$R^2 = \frac{\pi^2}{2 \cdot \delta^2} \cdot S_z(z_s, n_{1,1}) \cdot R_y(\eta_s) \cdot R_y(\eta_b)$	0,001	Resonance response factor
$\eta_b = \frac{4,6 \cdot h}{L(z_s)} \cdot f_z(z_s, n_{1,1})$	6,472	
$\eta_s = \frac{4,6 \cdot b}{L(z_s)} \cdot f_z(z_s, n_{1,1})$	21,075	
$R_s = \frac{1}{\eta_s} \cdot \frac{1}{2 \cdot \eta_s^2} \cdot (1 - \theta^{-2 \eta_s})$	0,143	
$R_b = \frac{1}{\eta_b} \cdot \frac{1}{2 \cdot \eta_b^2} \cdot (1 - \theta^{-2 \eta_b})$	0,046	

Calculation logarithmic decrement of damping

$S_d =$	0,05	logarithmic decrement of structural damping - Table F.2
$\delta_a = \frac{c_d \cdot \rho \cdot b \cdot V_m(z_s)}{2 \cdot n_1 \cdot m_b}$	0,60	logarithmic decrement of aerodynamic damping
$\delta_{sp} =$	0	when no special device is used.
$\delta = \delta_s + \delta_a + \delta_{sp}$	0,645	logarithmic decrement of damping

Structural factor $c_d \cdot c_s$

$c_d \cdot c_s = \frac{1 + 2 \cdot k_p \cdot I_w(z_s) \cdot \sqrt{B^2 + R^2}}{1 + 7 \cdot I_w(z_s)}$	0,843	
--	--------------	--

BS EN 1991-1-4:2005+A1:2010
 EN 1991-1-4:2005+A1:2010 (E)

- a) vertical structures such as buildings etc.
- b) parallel oscillator i.e. horizontal structures such as beams etc.
- c) portal structures such as signboards etc.

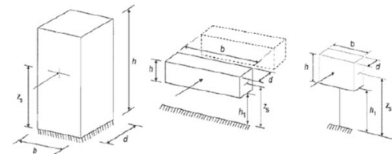

NOTE: Limitations are also given in 1.1 (2)

$z_1 = 0,6 \cdot b \geq z_{eq}$ $z_1 = h_1 \geq \frac{h}{2} \geq z_{eq}$ $z_1 = \frac{h}{2} \geq z_{eq}$

6.3.1 Structural factor $c_s \cdot c_d$

(1) The detailed procedure for calculating the structural factor $c_s \cdot c_d$ is given in Expression (6.1). This procedure can only be used if the conditions given in 6.3.1 (2) apply.

$c_s \cdot c_d = \frac{1 + 2 \cdot k_p \cdot I_w(z_s) \cdot \sqrt{B^2 + R^2}}{1 + 7 \cdot I_w(z_s)}$ (6.1)

where:

- z_s is the reference height for determining the structural factor, see Figure 6.1. For structures where Figure 6.1 does not apply z_s may be set equal to h , the height of the structure.
- k_p is the peak factor defined as the ratio of the maximum value of the fluctuating part of the response to its standard deviation
- I_w is the turbulence intensity defined in 4.4
- R^2 is the background factor, allowing for the lack of full correlation of the pressure on the structure surface
- R^2 is the resonance response factor, allowing for turbulence in resonance with the vibration mode

NOTE 1: The peak factor k_p takes into account the reduction effect on the wind action due to the non-stationary and non-uniformity of the peak wind pressures on the surface and may be obtained from Expression (6.3).

NOTE 2: The dynamic factor c_d takes into account the increasing effect from vibrations due to turbulence in resonance with the structure and may be obtained from Expression (6.1).

NOTE 3: This procedure to be used to determine $c_s \cdot c_d$ and R^2 may be given in the National Annex. A recommended procedure is given in Annex B. An alternative procedure is given in Annex C. As an indication to the users the differences in $c_s \cdot c_d$ using Annex C compared to Annex B does not exceed approximately 20%.

NOTE 4: Expression (6.1) shall only be used if all of the following requirements are met:

- the structure corresponds to one of the general shapes shown in Figure 6.1.
- only the along-wind vibration in the fundamental mode is significant, and this mode shape has a constant sign.

NOTE 5: The contribution to the response from the second or higher elongated vibration modes is negligible.

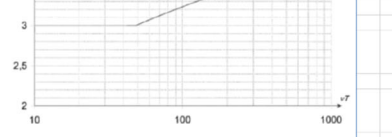

Figure B.2 – Peak factor

$k_p = \sqrt{2 \cdot \ln(v \cdot T)} + \frac{0,6}{\sqrt{2 \cdot \ln(v \cdot T)}}$ or $k_p = 3$ whichever is larger

Table F.2 – Approximate values of logarithmic decrement of structural damping in the fundamental mode, δ_s

Structural type	Structural damping δ_s
reinforced concrete buildings	0,10
steel buildings	0,05
mixed structures concrete + steel	0,08
reinforced concrete towers and chimneys	0,03
uninsulated welded steel stacks without external thermal insulation	0,012
uninsulated welded steel stack with external thermal insulation	0,020
steel stack with one liner with external thermal insulation	$h/b < 18$ 0,040 $20 \leq h/b \leq 24$ 0,040 $h/b \geq 28$ 0,014
steel stack with two or more liners with external thermal insulation*	$h/b < 18$ 0,020 $20 \leq h/b \leq 24$ 0,040 $h/b \geq 28$ 0,025
steel stack with internal brick liner	0,070
steel stack with internal granite	0,030
coupled stacks without liner	0,015
joined steel stack without liner	0,04
steel + lattice steel towers	welded 0,02
	high resistance bolts 0,03
composite bridges	ordinary bolts 0,05
	0,04
concrete bridges	prestressed without cracks 0,04
	with cracks 0,10
Timber bridges	0,06 - 0,12
Bridges, aluminum alloys	0,02
Bridges, glass or fibre reinforced plastic	0,04 - 0,08
cables	parallel cables 0,066
	spiral cables 0,020

Calculation of the structural factor $c_s \cdot c_d$ - for downwind ($\alpha=55^\circ$)

Geometrical and mechanical characteristics

III	= Terrain category
$z_s = 4,450$	(m) reference height of the structure
$z_0 = 0,1$	(m)
$z_{0m} = 5$	(m)
$V_m = 15$	(m/s) mean wind velocity
$\rho = 1,2070$	(kg/m ³) air density
$C_F = 1,755$	force coefficient for the structure (Section 7)
$C_{c0} = 1$	orography factor
Massa del 1° modo	65 (Kg) is the equivalent mass per unit length according to EN 1991-1-4 § F.4.
$I_{vz} = 0,256$	turbulence intensity

where:
 A is the turbulence factor. The value of I_v may be given in the National Annex. The recommended value for I_v is 0,5.
 C_F is the orography factor as described in 4.3.3
 z₀ is the roughness length, given in Table 4.1

Wind turbulence

$L(z) = L_1 \left(\frac{z}{z_0} \right)^{0,16}$ for $z > z_{0m}$	38,742	Turbulent length scale
$L(z) = L_1 \cdot L(z_{0m})$ for $z < z_{0m}$		
$Lt = 300$	m	
$zt = 200$	m	
$S_{\delta}(z, n) = \frac{n \cdot S_{\delta}(z, n)}{\sigma_{\delta}^2} = \frac{6,8 \cdot \{L(z)\}}{(1 + 10,2 \cdot L(z, n))^{0,3}}$	0,0263	non dimensional power spectral density
$T = 0,21$		Fundamental period of the structure
$n = 4,76$		natural frequency of the structure in Hz
$f(z, n) = \frac{n \cdot L(z)}{V_m(z)}$	12,299	non dimensionale frequency

Calculation of the background factor B - procedure 1 - Annex B

$B^2 = \frac{1}{1 + 0,9 \cdot \left(\frac{b+h}{L(z_s)} \right)^{0,65}}$	0,636	background factor
$b = 14,432$	(m) length tracker - see fig.6.1	
$h = 4,432$	(m) width tracker - see fig.6.1	

Calculation of the peak factor K_p

$k_p = \sqrt{2 \cdot \ln(v \cdot T)} + \frac{0,6}{\sqrt{2 \cdot \ln(v \cdot T)}}$	3,282	
$T = 600$	(sec) is the averaging time for the mean wind velocity	
$v = n_{1,1} \cdot \sqrt{\frac{R^2}{B^2 + R^2}}$	0,196	is the up-crossing frequency
$R^2 = \frac{\pi^2}{2 \cdot \delta} \cdot S_{\delta}(z_s, n_{1,1}) \cdot R_{\delta}(n_{1,1}) \cdot R_{\delta}(n_{1,1})$	0,001	Resonance response factor
$\eta_a = \frac{4,6 \cdot h}{L(z_s)} \cdot f(z_s, n_{1,1})$	6,472	
$\eta_b = \frac{4,6 \cdot b}{L(z_s)} \cdot f(z_s, n_{1,1})$	21,075	
$R_{\delta} = \frac{1}{\eta_b} \cdot \frac{1}{2 \cdot \eta_a^2} \cdot (1 - e^{-2 \cdot \eta_a})$	0,143	
$R_{\delta} = \frac{1}{\eta_b} \cdot \frac{1}{2 \cdot \eta_b^2} \cdot (1 - e^{-2 \cdot \eta_b})$	0,046	

Calculation logarithmic decrement of damping

$\delta_s = 0,05$	logarithmic decrement of structural damping - Table F.2
$\delta_a = \frac{C_d \cdot \rho \cdot b \cdot v_m(z_s)}{2 \cdot n_1 \cdot m_b}$	0,74 logarithmic decrement of aerodynamic damping
$\delta_{c0} = 0$	when no special device is used.
$\delta = \delta_s + \delta_a + \delta_{c0}$	0,791 logarithmic decrement of damping

Structural factor $c_d \cdot c_s$

$c_d \cdot c_s = \frac{1 + 2 \cdot k_p \cdot f(z_s) \cdot \sqrt{B^2 + R^2}}{1 + 7 \cdot f(z_s)}$	0,839
--	--------------

BS EN 1991-1-4:2005+A1:2010
 EN 1991-1-4:2005+A1:2010 (E)

- a) vertical structures such as buildings etc.
- b) parallel oscillator, i.e. horizontal structures such as beams etc.
- c) profile structures such as signboards etc.

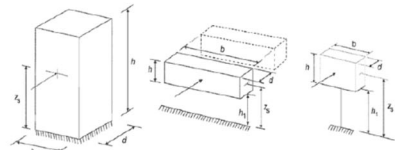

NOTE: Limitations are also given in 1.1 (2)

$$z_s = 0,6 \cdot h \geq z_{0m} \quad z_s = h_1 \geq \frac{h}{2} \geq z_{0m} \quad z_s = h_1 \geq \frac{h}{2} \geq z_{0m}$$

6.3.1 Structural factor $c_d \cdot c_s$

(1) The detailed procedure for calculating the structural factor $c_d \cdot c_s$ is given in Expression (6.1). This procedure can only be used if the conditions given in 6.3.1 (2) apply.

$$c_d \cdot c_s = \frac{1 + 2 \cdot k_p \cdot f(z_s) \cdot \sqrt{B^2 + R^2}}{1 + 7 \cdot f(z_s)} \quad (6.1)$$

where:

z_s is the reference height for determining the structural factor, see Figure 6.1. For structures where Figure 6.1 does not apply z_s may be set equal to h , the height of the structure.

k_p is the peak factor defined as the ratio of the maximum value of the fluctuating part of the response to its standard deviation.

L is the turbulence intensity defined in 4.4.

B^2 is the background factor, allowing for the lack of full correlation of the pressure on the structure surface.

R^2 is the resonance response factor, allowing for turbulence in resonance with the vibration mode.

NOTE 1: The site factor c_s takes into account the resonance effect on the wind action due to the non-uniformity of occurrence of the peak wind pressures on the surface and may be obtained from Expression (B.2).

$$c_s = \frac{1 + 7 \cdot f(z_s) \cdot \sqrt{B^2 + R^2}}{1 + 7 \cdot f(z_s)} \quad (B.2)$$

NOTE 2: The orography factor c_d takes into account the increasing effect from variations due to turbulence in resonance with the structure and may be obtained from Expression (B.3):

$$c_d = \frac{1 + 2 \cdot k_p \cdot f(z_s) \cdot \sqrt{B^2 + R^2}}{1 + 7 \cdot f(z_s)} \quad (B.3)$$

NOTE 3: This procedure is to be used to determine b , h and n may be given in the National Annex. A representative procedure is given in Annex B. An alternative procedure is given in Annex C. As an indication to the user the difference in k_p using Annex C, compared to Annex B, does not exceed approximately 5%.

NOTE 4: The expression (6.1) shall only be used if all of the following requirements are met:

- the structure corresponds to one of the general shapes shown in Figure 6.1.
- only the along-wind vibration in the fundamental mode is significant, and this mode shape has a constant sign.

NOTE: The contribution to the response from the second or higher alongwind vibration modes is negligible.

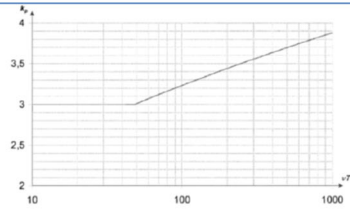

Figure B.2 — Peak factor

$$k_p = \sqrt{2 \cdot \ln(v \cdot T)} + \frac{0,6}{\sqrt{2 \cdot \ln(v \cdot T)}} \quad \text{or } k_p = 3 \text{ whichever is larger}$$

where:

Table F.2 — Approximate values of logarithmic decrement of structural damping in the fundamental mode, δ_s

Structural type	structural damping δ_s
reinforced concrete buildings	0.10
steel buildings	0.05
mixed structures concrete + steel	0.08
reinforced concrete towers and chimneys	0.03
unwelded welded steel stacks without external thermal insulation	0.012
unwelded welded steel stack with external thermal insulation	0.020
steel stack with one liner with external thermal insulation	$h/b < 18$ 0.020 $20 \leq h/b < 24$ 0.040
steel stack with two or more liners with external thermal insulation*	$h/b < 18$ 0.020 $20 \leq h/b < 24$ 0.040 $h/b \geq 28$ 0.025
steel stack with internal brick liner	0.070
steel stack with internal granite	0.030
coupled stacks without liner	0.015
guyed steel stack without liner	0.04
steel bridges	0.02
lattice steel towers	high resistance bolts 0.03 ordinary bolts 0.04
composite bridges	0.04
concrete bridges	prestressed without cracks 0.04 with cracks 0.10
Timber bridges	0.06 - 0.12
Bridges, aluminium alloys	0.05
Bridges, glass or fibre reinforced plastic	0.04 - 0.08
cables	parallel cables 0.006 spiral cables 0.020

Calculation of the structural factor $c_s \cdot c_d$ - for downwind ($\alpha=55^\circ$)

Geometrical and mechanical characteristics		
III	= Terrain category	
$z_s = 4,450$	(m) reference height of the structure	
$z_0 = 0,1$	(m)	
$z_{0m} = 5$	(m)	
$V_m = 15$	(m/s) mean wind velocity	
$\rho = 1,2070$	(kg/m ³) air density	
$C_F = 1,755$	force coefficient for the structure (Section 7)	
$C_{c0} = 1$	orography factor	
Massa del 1° modo	65	(Kg) is the equivalent mass per unit length according to EN 1991-1-4 § F.4.
$I_{vz} = 0,256$		turbulence intensity

Wind turbulence		
$L(z) = L_1 \left(\frac{z}{z_0} \right)^{0,16}$ for $z > z_{0m}$	38,742	Turbulent length scale
$L(z) = L_1(z_{0m})$ for $z < z_{0m}$		
$L_t = 300$	m	
$z_t = 200$	m	
$S_{\dot{w}}(z, n) = \frac{n \cdot S_{\dot{w}}(z_0)}{\sigma^2} = \frac{6,8 \cdot \{L(z)\}}{(1 + 10,2 \cdot L(z))^{0,3}}$	0,0263	non dimensional power spectral density
$T = 0,21$		Fundamental period of the structure
$n = 4,76$		natural frequency of the structure in Hz
$f(z, n) = \frac{n \cdot L(z)}{V_m(z)}$	12,299	non dimensionale frequency

Calculation of the background factor B - procedure 1 - Annex B		
$B^2 = \frac{1}{1 + 0,9 \cdot \left(\frac{b+h}{L(z_s)} \right)^{0,683}}$	0,636	background factor
$b = 14,432$	(m) length tracker - see fig.6.1	
$h = 4,432$	(m) width tracker - see fig.6.1	

Calculation of the peak factor K_p		
$k_p = \sqrt{2 \cdot \ln(v \cdot T)} + \frac{0,6}{\sqrt{2 \cdot \ln(v \cdot T)}}$	3,282	
$T = 600$	(sec) is the averaging time for the mean wind velocity	
$v = n_{1,1} \cdot \sqrt{B^2 + R^2}$	0,196	is the up-crossing frequency
$R^2 = \frac{\pi^2}{2 \cdot \delta} \cdot S_{\dot{w}}(z_s, n_1) \cdot R_y(\eta_1) \cdot R_y(\eta_2)$	0,001	Resonance response factor
$\eta_1 = \frac{4,6 \cdot h}{L(z_s)} \cdot f(z_s, n_{1,1})$	6,472	
$\eta_2 = \frac{4,6 \cdot b}{L(z_s)} \cdot f(z_s, n_{1,1})$	21,075	
$R_y = \frac{1}{\eta_0} \cdot \frac{1}{2 \cdot \eta_0^2} (1 - e^{-2\eta_0})$	0,143	
$R_{y0} = \frac{1}{\eta_0} \cdot \frac{1}{2 \cdot \eta_0^2} (1 - e^{-2\eta_0})$	0,046	

Calculation logarithmic decrement of damping		
$\delta_s = 0,05$		logarithmic decrement of structural damping - Table F.2
$\delta_a = \frac{C_d \cdot \rho \cdot b \cdot v_m(z_s)}{2 \cdot n_1 \cdot m_0}$	0,74	logarithmic decrement of aerodynamic damping
$\delta_{c0} = 0$		when no special device is used.
$\delta = \delta_s + \delta_a + \delta_{c0}$	0,791	logarithmic decrement of damping

Structural factor $c_d \cdot c_s$		
$C_d C_s = \frac{1 + 2 \cdot k_p \cdot f(z_s) \cdot \sqrt{B^2 + R^2}}{1 + 7 \cdot f(z_s)}$	0,839	

BS EN 1991-1-4:2005+A1:2010
 EN 1991-1-4:2005+A1:2010 (E)

- a) vertical structures such as buildings etc.
- b) parallel oscillator, i.e. horizontal structures such as beams etc.
- c) profile structures such as signboards etc.

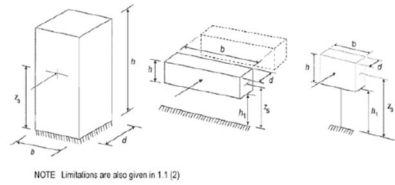

NOTE: Limitations are also given in 1.1 (2)

$$z_s = 0,6 \cdot h \geq z_{0m} \quad z_s = h_1 \geq \frac{h}{2} \geq z_{0m} \quad z_s = h_1 \geq \frac{h}{2} \geq z_{0m}$$

6.3.1 Structural factor c_d, c_s
 (1) The detailed procedure for calculating the structural factor c_d, c_s is given in Expression (6.1). This procedure can only be used if the conditions given in 6.3.1 (2) apply.

$$c_d c_s = \frac{1 + 2 \cdot k_p \cdot f(z_s) \cdot \sqrt{B^2 + R^2}}{1 + 7 \cdot f(z_s)} \quad (6.1)$$

where:

- z_s is the reference height for determining the structural factor, see Figure 6.1. For structures where Figure 6.1 does not apply z_s may be set equal to h , the height of the structure.
- k_p is the peak factor defined as the ratio of the maximum value of the fluctuating part of the response to its standard deviation
- L is the turbulence intensity defined in 4.4
- B^2 is the background factor, allowing for the lack of full correlation of the pressure on the structure surface
- R^2 is the resonance response factor, allowing for turbulence in resonance with the vibration mode

NOTE 1: The site factor c_s takes into account the resonance effect on the wind action due to the non-uniformity of occurrence of the peak wind pressures on the surface and may be obtained from Expression (B.2)

$$c_s = \frac{1 + 7 \cdot f(z_s) \cdot \sqrt{B^2 + R^2}}{1 + 7 \cdot f(z_s)} \quad (B.2)$$

NOTE 2: The orography factor c_d takes into account the increasing effect from vibration due to turbulence in resonance with the structure and may be obtained from Expression (B.3)

$$c_d = \frac{1 + 2 \cdot k_p \cdot f(z_s) \cdot \sqrt{B^2 + R^2}}{1 + 7 \cdot f(z_s)} \quad (B.3)$$

NOTE 3: This procedure is used to determine h_0, D and R may be given in the National Annex. A representative procedure is given in Annex B. An alternative procedure is given in Annex C. As an alternative to the latter the difference in k_p using Annex C, compared to Annex B, does not exceed approximately 5%.

GFP Expression (6.1) shall only be used if all of the following requirements are met:

- the structure corresponds to one of the general shapes shown in Figure 6.1.
- only the along-wind vibration in the fundamental mode is significant, and this mode shape has a constant sign.

NOTE: The contribution to the response from the second or higher alongwind vibration modes is negligible.

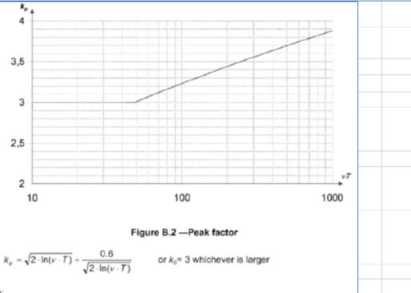

Structural type	structural damping δ
reinforced concrete buildings	0.10
steel buildings	0.05
mixed structures concrete + steel	0.08
reinforced concrete towers and chimneys	0.03
unwind welded steel stacks without external thermal insulation	0.012
unwind welded steel stack with external thermal insulation	0.020
steel stack with one liner with external thermal insulation	$n/b < 18$ 0.020 $20/nb < 24$ 0.040
steel stack with internal brick liner	$n/b \geq 20$ 0.014
steel stack with internal gunitite	$n/b < 18$ 0.020 $20/nb < 24$ 0.040
coupled stacks without liner	$n/b \geq 20$ 0.025
steel stack with internal brick liner	0.070
steel stack with internal gunitite	0.030
coupled stacks without liner	0.015
guyed steel stack without liner	0.04
steel bridges + lattice steel towers	welded 0.02 high resistance bolts 0.03 ordinary bolts 0.05
composite bridges	0.04
concrete bridges	prestressed without cracks 0.04 with cracks 0.10
Timber bridges	0.06 - 0.12
Bridges, aluminium alloys	0.05
Bridges, glass or fibre reinforced plastic	0.04 - 0.08
cables	parallel cables 0.006 spiral cables 0.020

Il coefficiente di pressione C_p dipende dalla tipologia e dalla geometria della costruzione e dal suo orientamento rispetto alla direzione del vento.

Il coefficiente d'attrito c_f dipende dalla scabrezza della superficie sulla quale il vento esercita l'azione tangente.

Entrambi questi coefficienti, definiti coefficienti aerodinamici, possono essere ricavati da dati suffragati da opportuna documentazione o da prove sperimentali in galleria del vento.

La condizione $\phi=1$ è sostanzialmente diversa da quella prevista per gli edifici in quanto l'eventuale ostruzione può essere offerta anche da elementi che non delimitano completamente e permanentemente lo spazio al di sotto della tettoia.

A valle della massima ostruzione si adotta $\phi=0$.

Le azioni aerodinamiche esercitate dal vento sulle tettoie dipendono fortemente dal grado di bloccaggio in quanto la presenza di un'ostruzione, anche soltanto sul lato sottovento, impedisce il passaggio dell'aria al di sotto della tettoia.



Figura C3.3.20 - Differenze nel flusso dell'aria per tettoie con $\phi=0$ e $\phi=1$



Figura C3.3.21 - Coefficienti di pressione complessiva per tettoie a semplice falda

Tabella C3.3.XV - Coefficienti di forza per tettoie a semplice falda (α in °).

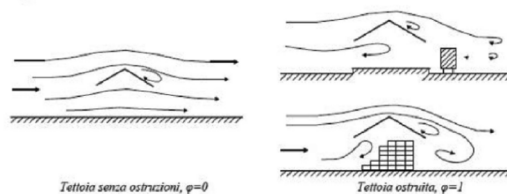
Valori positivi	Tutti i valori di ϕ	$c_F = +0,2 + \alpha/30$
Valori negativi	$\phi = 0$	$c_F = -0,5 - 1,3\alpha/30$
	$\phi = 1$	$c_F = -1,4$

Model A, $\alpha=0^\circ$

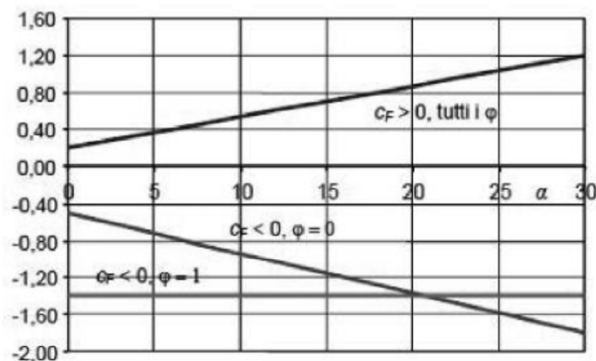
- $c_{pn,+0^\circ} = 0,2 + \alpha/30 = + 0,20$ upwind
- $c_{pn,-0^\circ} = -0,5 - 1,3 \cdot \alpha/30 = - 0,50$ downwind

Model B, $\alpha=30^\circ$

- $c_{pn,+30^\circ} = 0,2 + \alpha/30 = + 1,20$ upwind
- $c_{pn,-30^\circ} = -0,5 - 1,3 \cdot \alpha/30 = - 1,80$ downwind

Il calcolo della pressione del vento è determinato secondo la Sezione 3.3.4 del D.M. 17 gennaio 2018 - Norme Tecniche per le Costruzioni, basato sulla seguente espressione:

$$P_{w,\alpha} = q_{r,\alpha} \cdot c_e \cdot c_d \cdot c_{pn,\alpha}$$

Model A, $\alpha=0^\circ$

- $P_{w,+0^\circ} = q_{r,+0^\circ} \cdot c_e \cdot c_s c_d \cdot c_{pn,+0^\circ} = 436 \cdot 1,708 \cdot 0,905 \cdot 0,20 = 135 \text{ N/m}^2$.. (upwind);
- $P_{w,-0^\circ} = q_{r,-0^\circ} \cdot c_e \cdot c_s c_d \cdot c_{pn,-0^\circ} = -436 \cdot 1,708 \cdot 0,886 \cdot 0,5 = -330 \text{ N/m}^2$ (downwind);

Model B, $\alpha=30^\circ$

- $P_{w,+30^\circ} = q_{r,+30^\circ} \cdot c_e \cdot c_s c_d \cdot c_{pn,+30^\circ} = 136 \cdot 1 \cdot 0,847 \cdot 1,20 = 138 \text{ N/m}^2$ (upwind);
- $P_{w,-30^\circ} = q_{r,-30^\circ} \cdot c_e \cdot c_s c_d \cdot c_{pn,-30^\circ} = -136 \cdot 1 \cdot 0,838 \cdot 1,8 = -205 \text{ N/m}^2$. (downwind);

Model C, $\alpha=55^\circ$

- $P_{w,+55^\circ} = q_{r,+55^\circ} \cdot c_e \cdot c_s c_d \cdot c_{pn,+55^\circ} = 136 \cdot 1 \cdot 0,843 \cdot 1,410 = 161 \text{ N/m}^2$... (upwind);
- $P_{w,-55^\circ} = q_{r,-55^\circ} \cdot c_e \cdot c_s c_d \cdot c_{pn,-55^\circ} = -136 \cdot 1 \cdot 0,839 \cdot 1,755 = -200 \text{ N/m}^2$ (downwind);

AZIONE DELLA NEVE

Il calcolo del carico neve è determinato in base alle indicazioni del D.M. 17 gennaio 2018 – Norme Tecniche per le Costruzioni.

Il carico della neve al suolo dipende dalle condizioni locali di clima e di esposizione, considerata la variabilità delle precipitazioni nevose da zona a zona.

In mancanza di adeguate indagini statistiche e specifici studi locali, che tengano conto sia dell'altezza del manto nevoso che della sua densità, il carico di riferimento della neve al suolo, per località poste a quota inferiore a 1500 m sul livello del mare, non dovrà essere assunto minore di

quello calcolato in base alle espressioni riportate nel seguito, cui corrispondono valori associati ad un periodo di ritorno pari a 50 anni per le varie zone indicate nella Fig. 3.4.1.

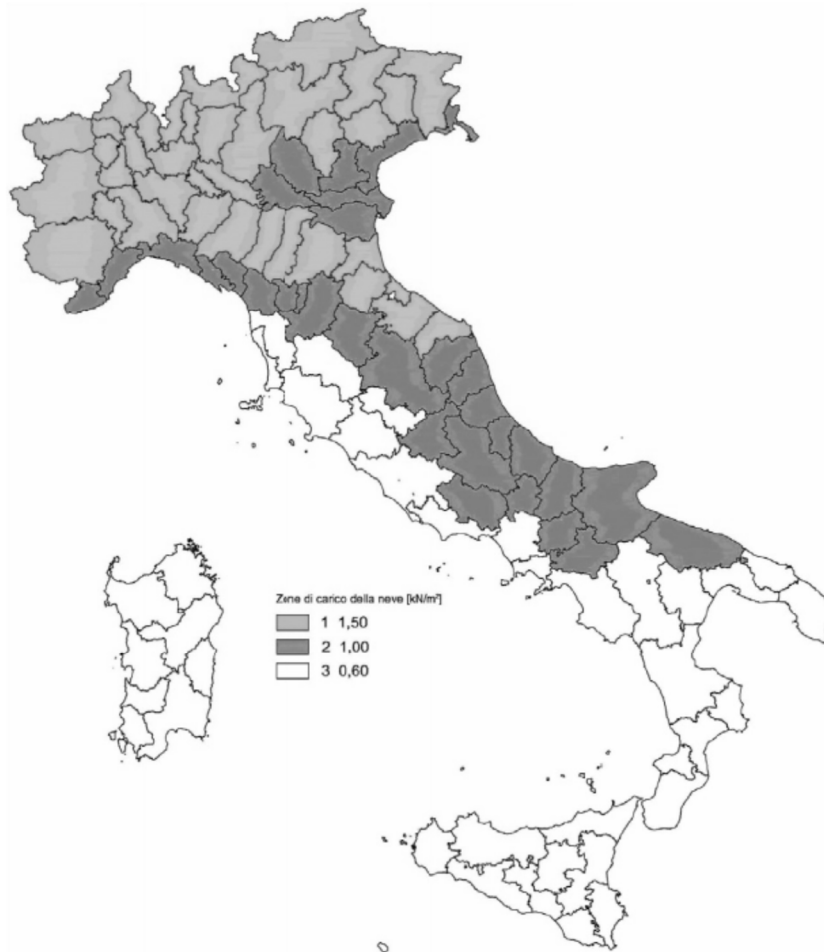

Il sito in oggetto è localizzato in zona 3, ad un'altitudine di circa 45 metri sul livello del mare.

Zona III

Agrigento, Brindisi, Cagliari, Caltanissetta, Carbonia-Iglesias, Caserta, Catania, Catanzaro, Cosenza, Crotona, Erna, Grosseto, Latina, Lecce, Livorno, Matera, Medio Campidano, Messina, Napoli, Nuoro, Ogliastra, Olbia-Tempio, Oristano, Palermo, Pisa, Potenza, Ragusa, Reggio Calabria, Roma, Salerno, Sassari, Siena, Siracusa, Taranto, Terni, Trapani, Vibo Valentia, Viterbo:

$$\begin{aligned} q_{sk} &= 0,60 \text{ kN/m}^2 & a_s &\leq 200 \text{ m} \\ q_{sk} &= 0,51 [1 + (a_s/481)^2] \text{ kN/m}^2 & a_s &> 200 \text{ m} \end{aligned} \quad [3.4.5]$$

Quindi avremo:

$$q_{sk} = 600 \text{ N/m}^2$$

Secondo l'allegato D della EN 1991-1-3: 2003 è possibile utilizzare un coefficiente che tenga conto di un periodo di ritorno diverso da 50 anni. Per un periodo di ritorno pari a 25 anni il carico di neve caratteristiche è

$$q_{sn} = q_{sk} \cdot \left\{ \frac{1 - V \frac{\sqrt{6}}{\pi} [\ln(-\ln(1 - P_n)) + 0,57722]}{(1 + 2,5923V)} \right\} = q_{sk} \cdot \left\{ \frac{1 - 0,6 \frac{\sqrt{6}}{\pi} [\ln(-\ln(1 - 1/25)) + 0,57722]}{(1 + 2,5923 \cdot 0,6)} \right\}$$

$$= 522,7 \text{ N/m}^2$$

I coefficienti di forma delle coperture dipendono dalla forma stessa della copertura e dall'inclinazione sull'orizzontale delle sue parti componenti e dalle condizioni climatiche locali del sito ove sorge la costruzione.

In assenza di dati suffragati da opportuna documentazione, i valori nominali del coefficiente di forma μ_1 possono essere ricavati dalla Tab. 3.4.II, essendo α , espresso in gradi sessagesimali, l'angolo formato dalla falda con l'orizzontale.

Tab. 3.4.II – Valori del coefficiente di forma

Coefficiente di forma	$0^\circ \leq \alpha \leq 30^\circ$	$30^\circ < \alpha < 60^\circ$	$\alpha \geq 60^\circ$
μ_1	0,8	$0,8 \cdot \frac{(60 - \alpha)}{30}$	0,0

Quindi avremo:

- Model (A) – $\alpha=0^\circ$ $\mu = 0,8;$
- Model (B) – $\alpha=30^\circ$ $\mu = 0,8;$
- Model (C) – $\alpha=55^\circ$ $\mu = \frac{0,8 \cdot (60 - \alpha)}{30} = \frac{0,8 \cdot (60 - 55)}{30} = 0,13;$

La struttura dell'inseguitore non può essere classificata come tetto monoposto standard perché durante un'intera giornata i pannelli ruotano da -55° a $+55^\circ$. Per tutte le configurazioni si presume che la semplificazione utilizzi un coefficiente di forma pari alla media tra i valori riportati per la configurazione principale:

$$\mu = \frac{(0,47 \cdot 25^\circ) + (0,8 \cdot 30^\circ)}{55^\circ} = 0,65$$

COEFFICIENTE DI ESPOSIZIONE

Il coefficiente di esposizione C_E tiene conto delle caratteristiche specifiche dell'area in cui sorge l'opera. Valori consigliati di questo coefficiente sono forniti in Tab. 3.4.I per diverse classi di esposizione.

Tab. 3.4.I – Valori di C_E per diverse classi di esposizione

Topografia	Descrizione	C_E
Battuta dai venti	Aree pianeggianti non ostruite esposte su tutti i lati, senza costruzioni o alberi più alti	0,9
Normale	Aree in cui non è presente una significativa rimozione di neve sulla costruzione prodotta dal vento, a causa del terreno, altre costruzioni o alberi	1,0
Riparata	Aree in cui la costruzione considerata è sensibilmente più bassa del circostante terreno o circondata da costruzioni o alberi più alti	1,1

Si assume

$$c_e = 0,9$$

COEFFICIENTE TERMICO

Il coefficiente termico c_t dovrebbe essere utilizzato per tenere conto della riduzione dei carichi di neve sui tetti con elevata trasmittanza termica.

Secondo il capitolo 3.4.5 del D.M. 17 gennaio 2018 - Norme Tecniche per le Costruzioni, il valore è:

$$c_t = 1$$

CALCOLO CARICO NEVE

Il calcolo del carico neve è determinato secondo il capitolo 3.4.1 del D.M. 17 gennaio 2018 - Norme Tecniche per le Costruzioni:

$$q_{s,\alpha} = \mu_{i,\alpha} \cdot c_e \cdot c_t \cdot q_{sk}$$

Pertanto, per le tre diverse configurazioni i carichi sono:

Model A, $\alpha=0^\circ$

$$- q_{s,0^\circ} = \mu_i \cdot c_e \cdot c_t \cdot s_k = 0,65 \cdot 0,9 \cdot 522,7 = 305,8 \text{ N/m}^2$$

Model B, $\alpha=30^\circ$

$$- q_{s,30^\circ} = \mu_i \cdot c_e \cdot c_t \cdot s_k = 0,65 \cdot 0,9 \cdot 522,7 = 305,8 \text{ N/m}^2$$

Model C, $\alpha=55^\circ$

$$- q_{s,55^\circ} = \mu_i \cdot c_e \cdot c_t \cdot s_k = 0,65 \cdot 0,9 \cdot 522,7 = 305,8 \text{ N/m}^2$$

4. COMBINAZIONI DELLE AZIONI

Le combinazioni di carico sono determinate secondo D.M. 17 gennaio 2018 - Norme Tecniche per le Costruzioni.

– Combinazione fondamentale, generalmente impiegata per gli stati limite ultimi (SLU):

$$\gamma_{G1} \cdot G_1 + \gamma_{G2} \cdot G_2 + \gamma_P \cdot P + \gamma_{Q1} \cdot Q_{k1} + \gamma_{Q2} \cdot \psi_{02} \cdot Q_{k2} + \gamma_{Q3} \cdot \psi_{03} \cdot Q_{k3} + \dots \quad [2.5.1]$$

Tab. 2.6.I – Coefficienti parziali per le azioni o per l'effetto delle azioni nelle verifiche SLU

		Coefficiente	EQU	A1	A2
		γ_F			
Carichi permanenti G_1	Favorevoli	γ_{G1}	0,9	1,0	1,0
	Sfavorevoli		1,1	1,3	1,0
Carichi permanenti non strutturali $G_2^{(1)}$	Favorevoli	γ_{G2}	0,8	0,8	0,8
	Sfavorevoli		1,5	1,5	1,3
Azioni variabili Q	Favorevoli	γ_{Q}	0,0	0,0	0,0
	Sfavorevoli		1,5	1,5	1,3

⁽¹⁾ Nel caso in cui l'intensità dei carichi permanenti non strutturali o di una parte di essi (ad es. carichi permanenti portati) sia ben definita in fase di progetto, per detti carichi o per la parte di essi nota si potranno adottare gli stessi coefficienti parziali validi per le azioni permanenti.

Tab. 2.5.I – Valori dei coefficienti di combinazione

Categoria/Azione variabile	ψ_{0j}	ψ_{1j}	ψ_{2j}
Categoria A - Ambienti ad uso residenziale	0,7	0,5	0,3
Categoria B - Uffici	0,7	0,5	0,3
Categoria C - Ambienti suscettibili di affollamento	0,7	0,7	0,6
Categoria D - Ambienti ad uso commerciale	0,7	0,7	0,6
Categoria E – Aree per immagazzinamento, uso commerciale e uso industriale Biblioteche, archivi, magazzini e ambienti ad uso industriale	1,0	0,9	0,8
Categoria F - Rimesse, parcheggi ed aree per il traffico di veicoli (per autoveicoli di peso ≤ 30 kN)	0,7	0,7	0,6
Categoria G – Rimesse, parcheggi ed aree per il traffico di veicoli (per autoveicoli di peso > 30 kN)	0,7	0,5	0,3
Categoria H - Coperture accessibili per sola manutenzione	0,0	0,0	0,0
Categoria I – Coperture praticabili	da valutarsi caso per caso		
Categoria K – Coperture per usi speciali (impianti, eliporti, ...)			
Vento	0,6	0,2	0,0
Neve (a quota ≤ 1000 m s.l.m.)	0,5	0,2	0,0
Neve (a quota > 1000 m s.l.m.)	0,7	0,5	0,2
Variazioni termiche	0,6	0,5	0,0

5. AZIONI ALLA BASE DEI PALI

I calcoli sono stati effettuati utilizzando un modello ad elementi finiti sviluppato mediante l'uso del software Winstrand (versione 2015-043).

Attraverso l'analisi delle combinazioni di carico sui tre modelli principali, i carichi peggiori da utilizzare durante le prove di estrazione risultano dal modello A.

MODEL (A) – $\alpha=0^\circ$

Azione perpendicolare verticale – Compressione

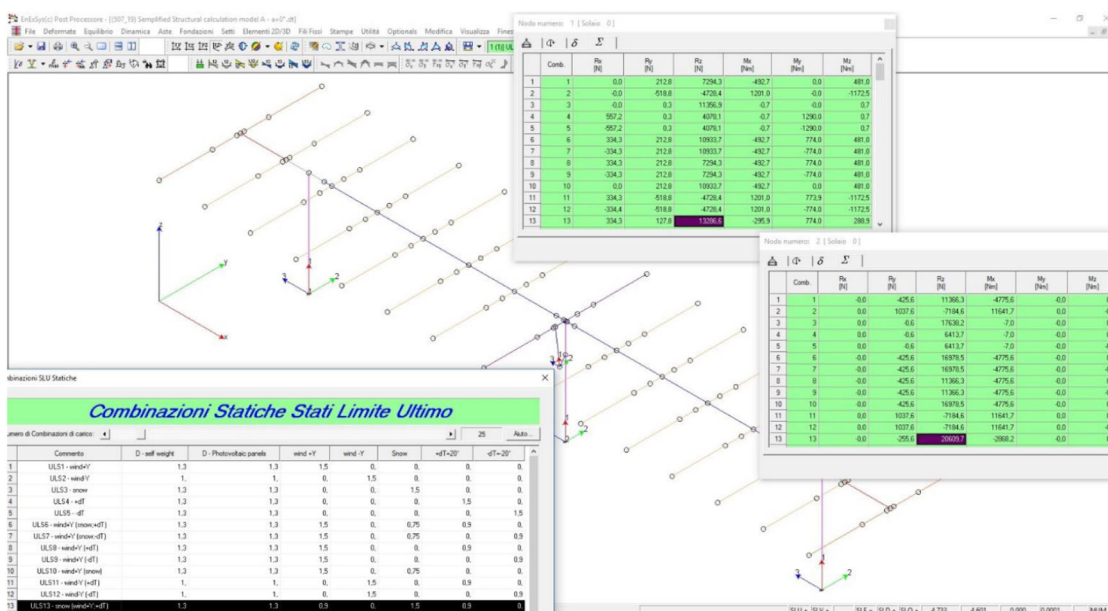

$N_{max} = 14147,1 \text{ N}$ - per i pali laterali

$N_{max} = 21987 \text{ N}$ - per il palo centrale del motore

Azione perpendicolare verticale – Trazione

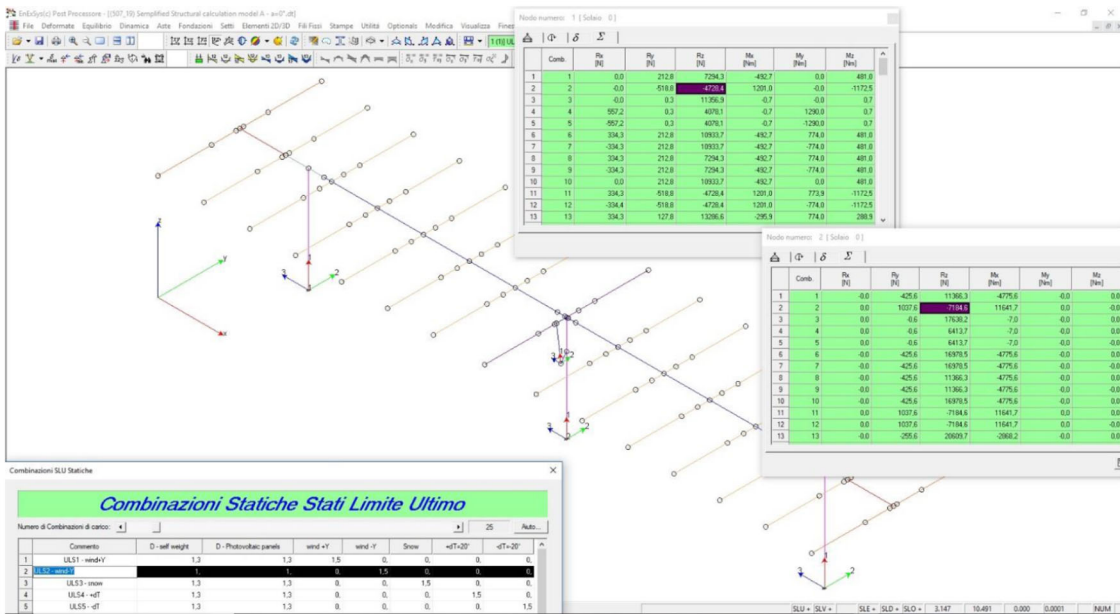

Nmax = -5539,2 N - per i pali laterali

Nmax = -8406 N - per il palo centrale del motore

Azione orizzontale

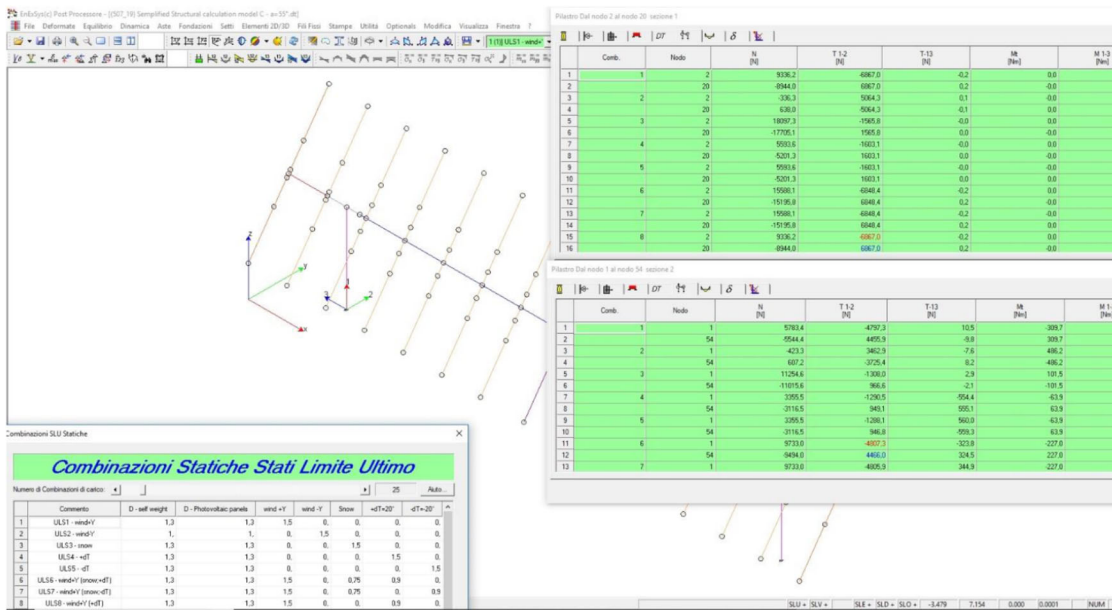

Tmax = 4807 N - per i pali laterali

Tmax = 6867 N - per il palo centrale del motore

Sulla base delle indicazioni NTC-2018, se vengono eseguite solo prove di carico di estrazione (azione perpendicolare verticale - trazione) con un minimo di 5 prove, il carico di progetto deve essere aumentato del coefficiente indicato al paragrafo 6.4.3.1.1.

6.4.3.1.1 Resistenze di pali soggetti a carichi assiali

Il valore di progetto R_d della resistenza si ottiene a partire dal valore caratteristico R_k applicando i coefficienti parziali γ_R della Tab. 6.4.II.

Tab. 6.4.II – Coefficienti parziali γ_R da applicare alle resistenze caratteristiche a carico verticale dei pali

Resistenza	Simbolo	Pali infissi (R3)	Pali trivellati (R3)	Pali ad elica continua (R3)
	γ_R	(R3)	(R3)	(R3)
Base	γ_b	1,15	1,35	1,3
Laterale in compressione	γ_s	1,15	1,15	1,15
Totale (*)	γ	1,15	1,30	1,25
Laterale in trazione	γ_{st}	1,25	1,25	1,25

(*) da applicare alle resistenze caratteristiche dedotte dai risultati di prove di carico di progetto.

(a) Se il valore caratteristico della resistenza a compressione del palo, $R_{c,k}$, o a trazione, $R_{t,k}$, è dedotto dai corrispondenti valori $R_{c,m}$ o $R_{t,m}$ ottenuti elaborando i risultati di una o più prove di carico di progetto, il valore caratteristico della resistenza a compressione e a trazione è pari al minore dei valori ottenuti applicando al valore medio e al valore minimo delle resistenze misurate i fattori di correlazione ξ riportati nella Tab. 6.4.III, in funzione del numero n di prove di carico su pali pilota:

$$R_{c,k} = \text{Min} \left\{ \frac{(R_{c,m})_{\text{media}}}{\xi_1}, \frac{(R_{c,m})_{\text{min}}}{\xi_2} \right\} \quad [6.4.1]$$

$$R_{t,k} = \text{Min} \left\{ \frac{(R_{t,m})_{\text{media}}}{\xi_1}, \frac{(R_{t,m})_{\text{min}}}{\xi_2} \right\} \quad [6.4.2]$$

Tab. 6.4.III - Fattori di correlazione ξ per la determinazione della resistenza caratteristica a partire dai risultati di prove di carico statico su pali pilota

Numero di prove di carico	1	2	3	4	≥ 5
ξ_1	1,40	1,30	1,20	1,10	1,0
ξ_2	1,40	1,20	1,05	1,00	1,0

Secondo le indicazioni precedentemente riportate, le forze massime che devono essere applicate per le prove di estrazione sono:

Massima azione verticale perpendicolare:

$N_{\text{max, trac test}} = N_{\text{max, trac}} \times Y_{\text{st}}$

$N_{\text{max, trac test}} = -8406 \times 1,25 = 10508 \text{ N} = 1072 \text{ Kg}$

6. CALCOLO DELLA LUNGHEZZA DEI PALI

Questo capitolo analizza i controlli geotecnici sui pali della struttura dell'inseguitore.

Il calcolo della lunghezza del palo nel terreno viene effettuato con il software GEOSTRU MP,

Le dimensioni geometriche del palo sono:

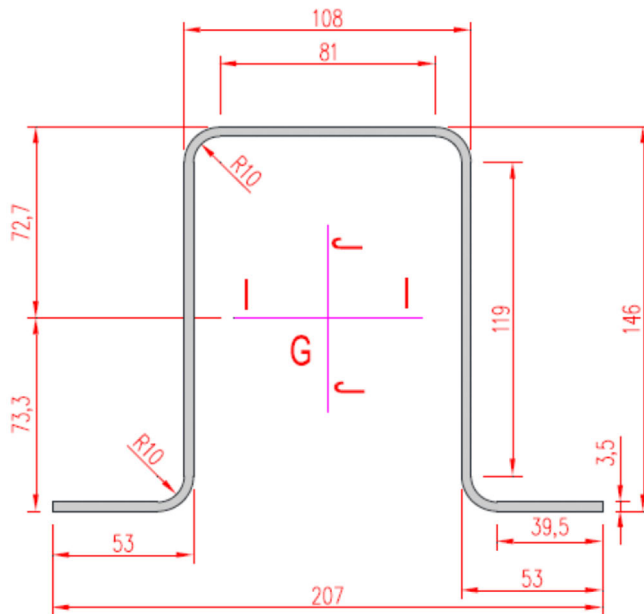

Inertia Characteristics (dimensions in mm)

- Area:1651.3960
- Perimeter:950.6549
- Barycenter: X: 0.0000 / Y: 0.0000
- Moments of inertia: X: 4991037.7770 / Y: 5118921.7495
- Products of inertia:XY: 0.0000
- Main moments and direction X-Y compared to the barycenter:
 - I: 4991037.7770 lungo [1.0000 0.0000]
 - J: 5118921.7495 lungo [0.0000 1.0000]

Per il calcolo del carico della resistenza del palo di carico, si inserisce nel software il diametro equivalente:

$$D_{eq} = 951/\pi = 303mm \cong 300mm$$

DESIGN RESISTANCE TO AXIAL LOADS – combination with $N_{max} = -8,406 \text{ kN}$

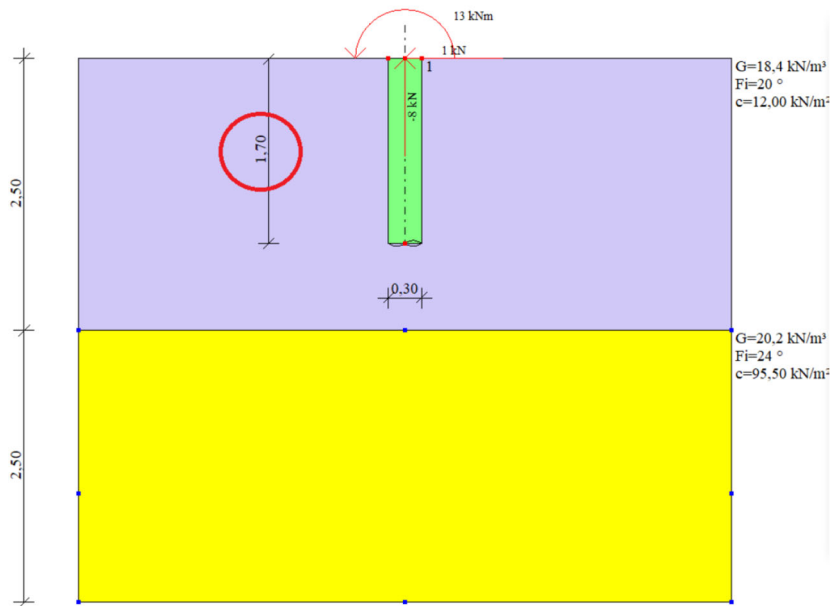

Descrizione	D [m]	L [m]	Nq	Nc	F _i /C strato punta Palo (°)/[kN/m²]	Peso palo [kN]	S _{vl} [kN/m²]	Carico limite punta [kN]	Carico limite laterale [kN]	Carico limite verticale [kN]	Carico limite orizzontale [kN]
A1+M1+R3	0,303	1,7	--	9	-/12,00	0,233849	31,195	--	18,44787	18,68172	17,12693 [Medio]
							Rc, Min	--	18,45	18,68	17,13
							Rc, Max	--	18,45	18,68	17,13
							Rc, Med	--	18,45	18,68	17,13
							Rk	--	11,53	11,68	10,70
							Rd [R3]	--	9,22	9,46	6,69
							Fattore sicurezza verticale				1,13
							Fattore sicurezza orizzontale				5,62

La lunghezza calcolata è:

$L_{emb} = 1700 \text{ mm}$.

Al fine di utilizzare la stessa lunghezza di inclinazione del progetto e ottenere lo stesso fattore di sicurezza, è stato deciso di utilizzare un test di carico di estrazione aumentato per ottenere risultati coerenti.

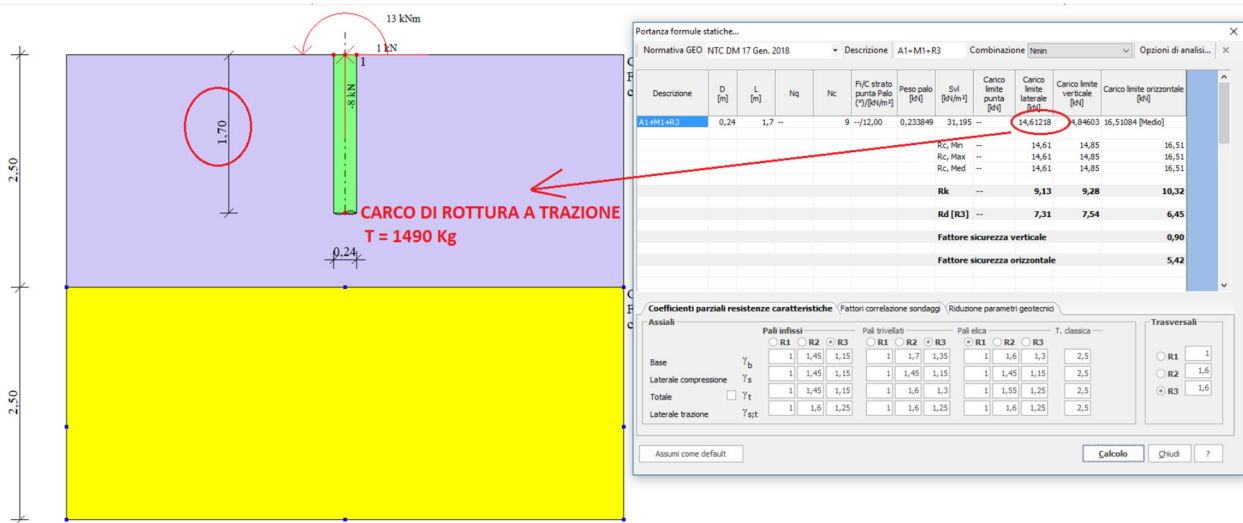

Pertanto, la lunghezza di inclinazione calcolata è $Lemb = 1700 \text{ mm}$ e l'equivalente della massima azione perpendicolare verticale (trazione) è $Nmax, \text{trac. test} = 1490 \text{ kg}$ ($\gg Nmax, \text{trac. test} = 1072 \text{ kg}$).

I tecnici:

Arch. Gianluca Francavilla

Ing. Piero Farenti

