

Technical Documentation

Sound Level Calibrator
Type 4231

Brüel & Kjær 

English BB 0910-12

· User Manual · User Manual · User Manual · User Manual · User Manual ·
Manual · User Manual · User Manual · User Manual · User Manual ·
User Manual · User Manual · User Manual · User Manual · User Manual ·
Manual · User Manual · User Manual · User Manual · User Manual ·
User Manual · User Manual · User Manual · User Manual · User Manual

User Manual
Sound Level Calibrator
Type 4231

From serial no. 1723539

January 1994

Brüel & Kjær

BB 0910-12

About this User Manual

This User Manual concerns the use of Sound Level Calibrator Type 4231.

Chapter 1 describes the basic functions of the calibrator and how to prepare it for use.

Chapter 2 gives a basic calibration procedure.

Chapter 3 contains technical details about the principle of operation of the calibrator and how it is affected by ambient conditions.

Chapter 4 is about service and repair.

Chapter 5 contains the specifications.

Copyright © 1993, Brüel & Kjær A/S

All rights reserved. No part of this publication may be reproduced or distributed in any form or by any means without prior consent in writing from Brüel & Kjær A/S, Nærum, Denmark.

Contents

1	Introduction and Controls.....	1-1
1.1	Description	1-2
1.2	On/Off Button	1-2
1.3	+20 dB Level Step	1-3
1.4	Batteries	1-3
1.5	Adaptors	1-5
2	Operation	2-1
2.1	Calibration Procedure.....	2-2
2.2	Correction for Microphone Characteristics	2-3
3	Characteristics.....	3-1
3.1	Influence of Ambient Pressure	3-2
3.2	Influence of Ambient Temperature	3-2
3.3	Influence of Load Volume	3-3
3.4	Traceability	3-4
3.5	Stability	3-4
3.6	Recalibration of the Calibrator.....	3-4
3.7	How the Calibrator Works.....	3-5
3.8	Construction.....	3-7

4	Service and Repair.....	4-1
5	Specifications.....	5-1
	Specifications 4231.....	5-2
	Ordering Information.....	5-2
6	Index.....	6-1

Chapter 1

Introduction and Controls

1.1 Description.....	1-2
1.2 On/Off Button.....	1-2
1.3 +20 dB Level Step.....	1-3
1.4 Batteries.....	1-3
1.5 Adaptors.....	1-5

1.1 Description

Sound Level Calibrator Type 4231 is used to calibrate sound level meters and other sound measurement equipment. You can calibrate 1" diameter microphones directly and $\frac{1}{2}$ " microphones using the adaptor (UC 0210) supplied with the calibrator. With available adaptors (see section 1.5), you can calibrate other microphones and instruments.

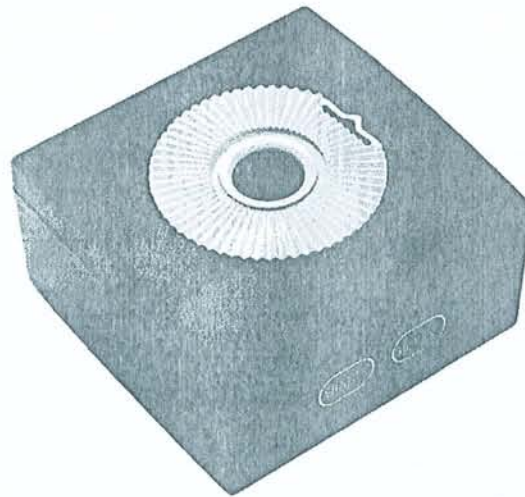

Fig. 1.1 Sound Level Calibrator Type 4231

1.2 On/Off Button

Press the **On/Off** button (see Fig. 1.1) to start the calibrator. To save the batteries, the calibrator will automatically switch off again after a short time if you have not fitted a microphone.

If you are using a coupler smaller than $\frac{1}{2}$ " , the calibrator will not switch off automatically, even when there is no microphone fitted.

When you want the calibrator to keep working, even when there is no microphone or coupler fitted, put it down on a flat surface (such as a table) with the opening facing downwards. This is useful if you are calibrating several microphones one after the other.

Note: If the calibrator cannot maintain the specified sound pressure level, for example because of a leakage at the adaptor, it will switch off automatically.

To switch the calibrator off, press the **On/Off** button again.

1.3 +20 dB Level Step

The **+20 dB** level step button (see Fig. 1.1) increases the sound pressure level by 20 dB (to 114 dB). Using this button you can calibrate in noisy environments and check linearity.

If the calibrator is already switched on when you press the **+20 dB** level step button, the 114 dB sound pressure level is only produced as long as you hold the button down.

To start the calibrator so that it works at the higher level all the time, hold down the **+20 dB** button and press the **On/Off** button. The calibrator will now work at the 114 dB level until it is switched off.

Note: With some special microphones (for example, Weather-proof Microphone Unit Type 4184) the calibrator cannot maintain the 114 dB level, and will switch off automatically.

1.4 Batteries

The calibrator uses two 1.5 V IEC Type LR6 (American "AA") size batteries, Brüel&Kjær order number QB0013. If you want

to use other types of batteries, we recommend that you choose only good quality alkaline batteries.

When the batteries need changing, the calibrator stops working continuously, and only works if you hold down the **On/Off** button. There is enough power left in the batteries to use the calibrator in this way for about 10 hours. The sound pressure level generated will always be within the tolerances as long as the calibrator can be operated.

To keep the batteries and the calibrator in good condition:

- If you are not going to use the calibrator for a long period of time take the batteries out
- Always take old batteries out as soon as they become exhausted

To Replace the Batteries

1. Take the calibrator out of its case.
2. Remove the 1/2" adaptor.
3. Remove the two battery lids on each side of the 1/2" adaptor by sliding them outwards (see Fig.1.2).
4. Replace the batteries making sure that the polarity of the batteries is the same as the markings in each battery compartment.
5. Replace both battery compartment lids and the 1/2" adaptor on the calibrator and put it back in its case.

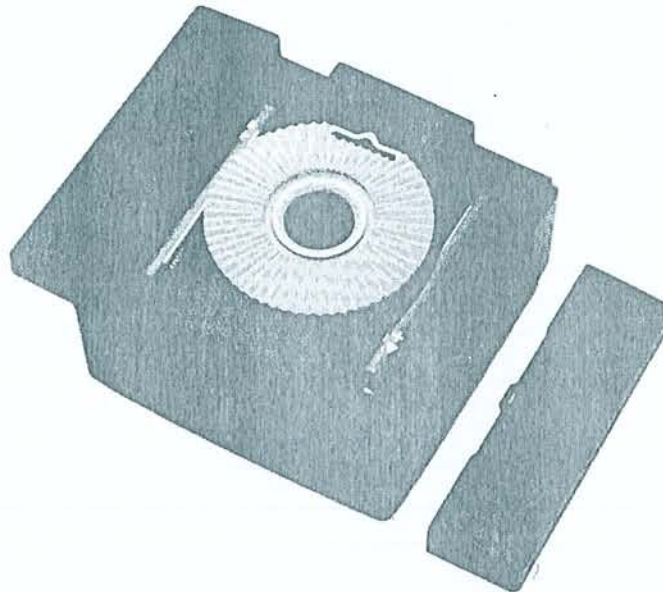

Fig.1.2 Replacing the batteries

1.5 Adaptors

Sound Level Calibrator Type 4231 is mainly intended to be used when calibrating instruments with 1" and 1/2" microphones. With other adaptors, you can also use the calibrator for calibrating the following microphones and instruments:

- Brüel & Kjær 1/4" and 1/8" Microphones
- Noise Dose Meter Type 4436
- Weatherproof Microphone Unit Type 4184
- Head and Torso Simulator Type 4128
- Brüel & Kjær Intensity Probe Sets
- Brüel & Kjær *Studio Microphones

When you are using these adaptors, the accuracy is reduced slightly and you must use a Calibration Level Correction to compensate for this. The adaptors and Calibration Level Corrections are shown in Table 1.1.

Instrument	Adaptor	Cal. Level Correction
Brüel & Kjær $\frac{1}{4}$ Microphones	DP 0775	0.0 dB
Brüel & Kjær $\frac{1}{8}$ Microphones	DP 0774	
Brüel & Kjær Studio Micro-phones Types 4003/4006	DP 0682	
	Types 4004/4007 DP 0750	
Noise Dose Meter Type 4436	DP 0781 ^①	
Head and Torso Simulator Type 4128	DP 0887	+0.5 dB
Weatherproof Microphone Unit Type 4184 (with Protection Tube UA 1072)	UC 0210 ^②	+2.0 dB
Brüel & Kjær Intensity Probe Sets	DP 0888 ^③	+3.0 dB

^① This adaptor delivered with the noise dose meter.

^② The 114 dB level cannot be used.

^③ This only performs an SPL calibration. For intensity calibrations use Sound Intensity Calibrator Type 3541.

Table 1.1 Adaptors and Calibration Level Corrections for Sound Level Calibrator Type 4231

Note: When you are using these adaptors, the automatic “switch-off” circuit on the calibrator does not work. Because of this, you must switch off the calibrator manually.

Calibrating 1" Microphones

To calibrate a 1" microphone, take out the green $\frac{1}{2}$ " adaptor (UC 0210), which is supplied with the calibrator, by twisting it about $\frac{1}{4}$ of a turn anti-clockwise as shown in Fig. 1.3. Then fit the microphone into the 1" opening underneath for calibrating it.

* For all enquires about Brüel & Kjær Studio Microphones please contact Danish Pro Audio ApS, DK-3450 Allerød, Denmark. Tel.: (+45) 4814 2828, Fax: (+45) 4814 2700.

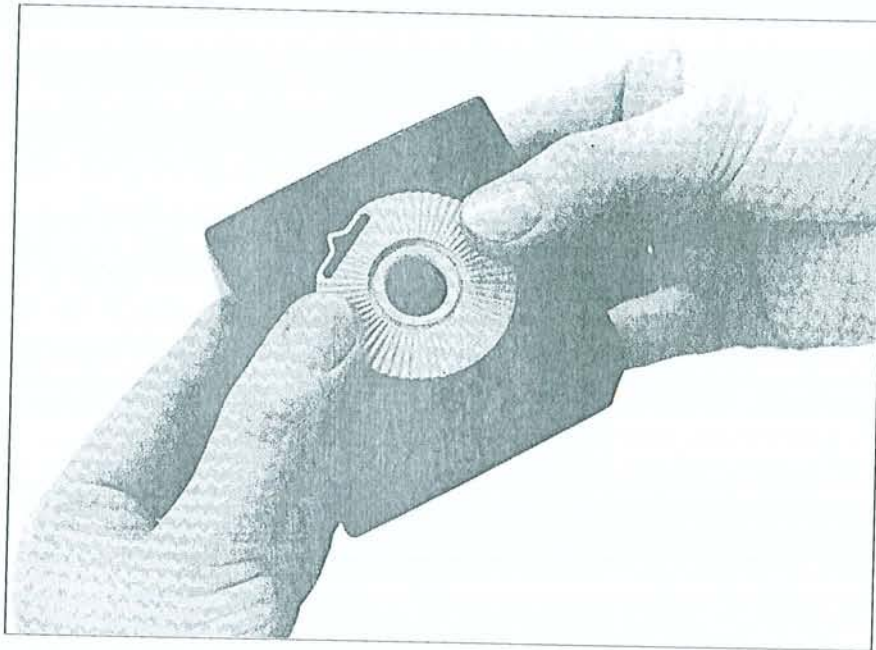

Fig.1.3 Removing the 1/2" adaptor

Chapter 2

Operation

2.1 Calibration Procedure	2-2
2.2 Correction for Microphone Characteristics	2-3

2.1 Calibration Procedure

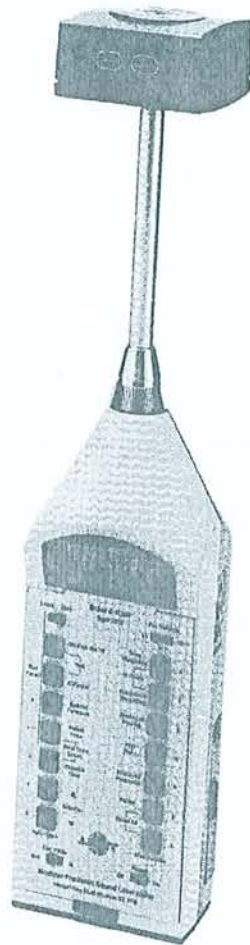

Fig.2.1 Positioning the calibrator on a Modular Precision Sound Level Meter Type 2231

1. Select the correct adaptor for the microphone you want to calibrate and fit it to the calibrator (see section 1.5).

2. Press the microphone into the opening in the calibrator, see Fig.2.1.
3. Press the **On/Off** button on the calibrator.
4. Adjust the sensitivity of measuring equipment to read the correct value.

Refer to Table 2.1 for corrected calibration levels for various types of microphones and sound fields.

Remember: When you are using special adaptors add the Calibration Level Correction for the particular adaptor (see Table 1.1).

5. Remove the calibrator from the microphone.
6. Switch off the calibrator before closing the flap on its case.

2.2 Correction for Microphone Characteristics

The sound pressure level produced by the calibrator is 94.0 dB re 20 μ Pa. However, if you are calibrating a microphone which is not going to be used for pressure measurements (for example, microphones used on sound level meters should be calibrated for free- or random-field measurements) a small correction is necessary. This correction compensates for the difference between the microphone pressure sensitivity that you get with the calibrator and the sensitivity in the actual sound field (free or random) in which you are using the microphone. Table 2.1 shows the corrected calibration levels obtained with the calibrator for different sound fields and for different sizes of Brüel&Kjær Microphones.

Chapter 3

Characteristics

3.1 Influence of Ambient Pressure.....	3-2
3.2 Influence of Ambient Temperature.....	3-2
3.3 Influence of Load Volume.....	3-3
3.4 Traceability.....	3-4
3.5 Stability.....	3-4
3.6 Recalibration of the Calibrator.....	3-4
3.7 How the Calibrator Works.....	3-5
3.8 Construction.....	3-7

3.1 Influence of Ambient Pressure

For normal use, the influence of atmospheric pressure on the sound pressure level produced by the calibrator is so small that you can ignore it.

Fig.3.1 shows the effect that variations in atmospheric pressure have on the sound pressure level produced. It is a linear relationship caused by changes in the sensitivity of the calibrator's reference microphone which varies directly with changes in static pressure.

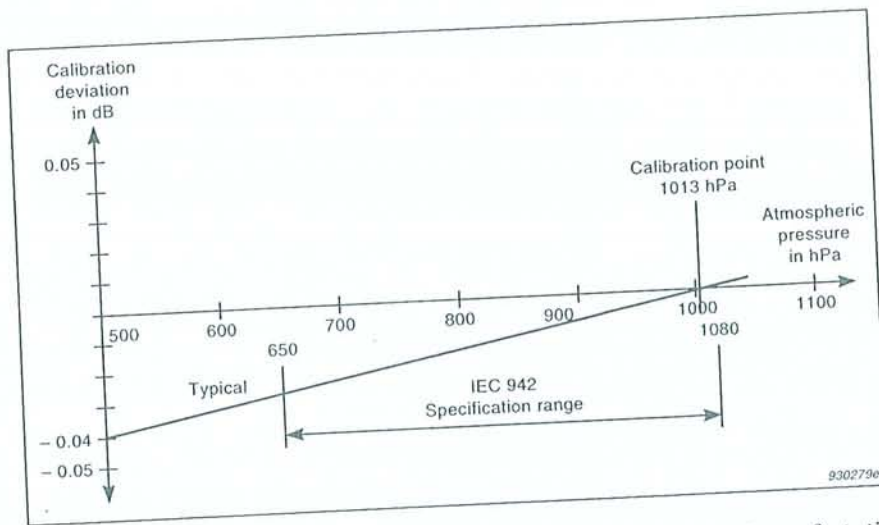

Fig.3.1 Typical variation of sound pressure level as a function of static pressure at 20°C

3.2 Influence of Ambient Temperature

Under normal conditions, the influence of changes in ambient temperature on the sound pressure level produced by the calibrator are so small that you can ignore them.

You can see the effect of ambient temperature changes in Fig.3.2. These are mainly caused by variations in the reference micro-

phone's sensitivity. The electronic compensation corrects for the influence of temperature on the microphone's nominal sensitivity, and the deviation is caused by the variation from this nominal value.

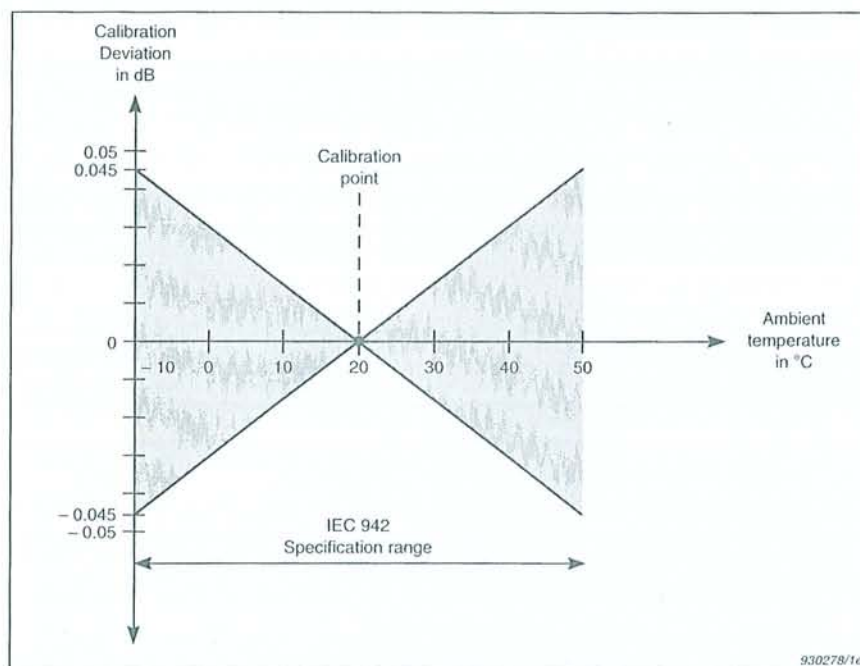

Fig.3.2 Typical calibration uncertainty at 1013hPa due to variation in ambient temperature

3.3 Influence of Load Volume

The calibrator uses a feed-back technique to create a very low output impedance (refer to section 3.7 for a more detailed description). This minimizes the influence of varying acoustic loading and, as a result, the sound pressure level does not change for different sizes of microphone (from $\frac{1}{8}$ " to 1"). This means that you do not need to have an exact fit between the coupler and the microphone you are calibrating.

The specified equivalent coupler volume is based on the assumption that the sound field generated in the coupler is homogeneous. That is, both the built-in reference microphone and the microphone you are calibrating are exposed to the same sound pressure level.

3.4 Traceability

Calibration of Sound Level Calibrator Type 4231 is traceable to both the Danish Primary Laboratory of Acoustics (DPLA) and the National Institute of Standards and Technology (NIST), USA.

3.5 Stability

The stability mentioned in the specification consists of two parts:

- A short-term stability – (defined in IEC 942) which covers fluctuation and repeatability
- A long-term stability – based on an analysis of the electrical circuit/reference microphone.

Note: These are only valid for calibrators that have not been subjected to conditions outside the specified environmental range.

3.6 Recalibration of the Calibrator

The ANSI S1.40 standard recommends that you should recalibrate your calibrator at least once a year. This can be done by an authorised Brüel&Kjær representative or by a recognised standards laboratory or institution.

3.7 How the Calibrator Works

The calibrator uses a feed-back loop based on a reference microphone (see Fig.3.3). Using this technique, the calibrator is highly stable and almost insensitive to variations in static pressure and temperature. The reference microphone has been specially developed for this purpose and is optimized for the 1 kHz calibration frequency.

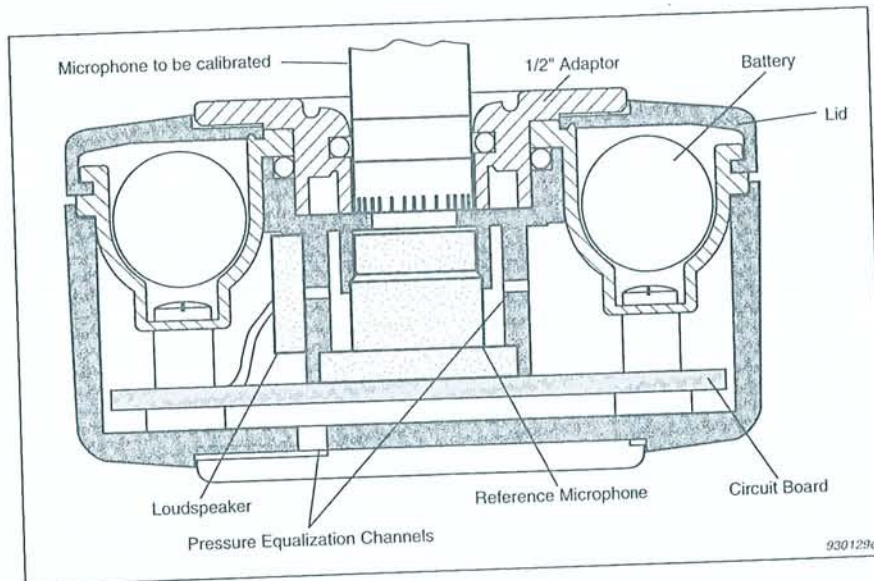

Fig.3.3 Cross-sectional view of the calibrator

Fig.3.4 shows a block diagram that illustrates how the calibrator's electronic circuit works. The main components of the diagram are described in the following sections:

Feed-back Circuit

The signal from the microphone is fed to the feed-back circuit. The feed-back circuit contains:

- a band-pass filter
- a temperature compensation circuit

Chapter 3 – Characteristics How the Calibrator Works

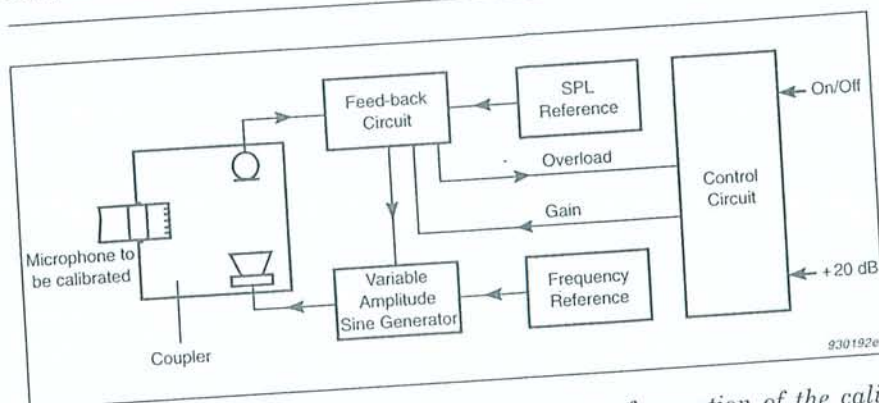

Fig.3.4 Block diagram illustrating the principle of operation of the calibrator

- a detector
- an adjustment for the sound pressure level
- an amplifier with adjustable gain (the gain is reduced by 20 dB when the +20 dB level step is activated).

SPL Reference

The SPL reference is a voltage that the calibrator uses for two critical applications: for comparison with the feed-back and as the polarization for the reference microphone. Using the same voltage source for these applications makes the calibrator insensitive to variation in this voltage.

Variable Amplitude Sine Generator

The variable amplitude sine generator produces a 1 kHz sine wave which drives the loudspeaker (see Fig.3.4). The output from feed-back circuit is used to control the signal produced by the variable amplitude sine generator.

Frequency Reference

This is a quartz-controlled oscillator used to maintain the stability of the frequency of the sine wave produced by the variable amplitude sine generator.

Control Circuit

The control circuit switches the calibrator on or off when you press the **On/Off** button. It also adjusts the gain in the feed-back circuit when the **+20 dB** button is pressed.

The control circuit checks to make sure that the sound pressure level generated by the calibrator is within the accepted range. If the sound pressure level is outside the accepted range (for example, if a test microphone has not been detected), the circuit automatically switches the calibrator off after approximately four seconds.

3.8 Construction

To avoid large pressures inside the coupler when you insert a microphone, the coupler and the cavity, inside as well as outside the calibrator are connected by channels. These channels also reduce the pressure variations caused by handling the calibrator. These pressure equalization channels have a low cut-off frequency to minimize the effect of outside noise.

The coupler volume in the calibrator is shaped like a Helmholtz resonator and has a resonance frequency of 1 kHz. This makes the acoustic system efficient and suppresses higher order distortion components.

Chapter 3 -- Characteristics
Construction

Chapter 4

Service and Repair

The calibrator is designed and constructed to provide you with many years of reliable operation. However, if a fault occurs which impairs its correct function, then remove the batteries to prevent the risk of further damage. For repair, contact your local Brüel & Kjær service representative.

Chapter 5

Specifications

Specifications 4231

STANDARDS SATISFIED:

IEC942 (1988), Sound Calibrators, Class 1
ANSI S1.40-1984, Specifications for Acoustic Calibrators

SPECIFIED MICROPHONE TYPES:

(Conforms to IEC 942 Class 1)
Brüel&Kjær 1" and 1/2", 1/4", 1/8" with adaptor

NOMINAL SOUND PRESSURE LEVEL:

94.0 dB \pm 0.2 dB or 114.0 dB \pm 0.2 dB re 20 μ Pa at reference conditions

EQUIVALENT FREE-FIELD LEVEL:

(0° incidence, re Nominal Sound Pressure Level)
-0.15 dB for 1/2" Brüel&Kjær Microphones

EQUIVALENT RANDOM INCIDENCE LEVEL:

(re Nominal Sound Pressure Level)
+0.0 dB for 1", 1/2", 1/4" and 1/8" Brüel&Kjær Microphones

REFERENCE CONDITIONS:

Ambient Temperature: 20°C (68°F)
Ambient Pressure: 1013 hPa
Ambient Humidity: 65% RH
Load: Microphone Type 4134 (0.25 cm³)

AMBIENT CONDITIONS:

Temperature: -10° to +50°C (14° to 122°F)
Pressure: 650 to 1080 hPa
Humidity: 10 to 90% RH (without condensation)
Effective Load Volume: 0 to 1.5 cm³

INFLUENCE OF AMBIENT CONDITIONS:

(typical)
Temperature Coefficient: \pm 0.0015 dB/°C
Pressure Coefficient: $+8 \cdot 10^{-5}$ dB/hPa
Humidity Coefficient: 0.001 dB/%RH

LEVEL STABILITY:

Short Term: Better than 0.02 dB (as specified in IEC 942)

One Year: Better than 0.05 dB ($\sigma=96\%$)

Stabilisation Time: 5.0 s

NOMINAL EFFECTIVE COUPLER VOLUME:

>200 cm³ at reference conditions

FREQUENCY:

1 kHz \pm 0.1%

TOTAL HARMONIC DISTORTION (THD):

<1%

STORAGE TEMPERATURE RANGE:

-25° to 70°C (-13° to 158°F)

PROTECTION CLASS:

(with leather protection case)
IP50 (IEC 529)

BATTERIES:

Type: 2 \times 1.5 V IEC Type LR6 ("AA" size)
Lifetime: Typically 100 hours continuous operation with alkaline batteries at 20°C (68°F)
Check: When about ten hours of the batteries' lifetime remain, the calibrator can only be operated by keeping the On/Off button pressed. The generated sound level will be within the tolerances as long as the calibrator can be operated

DIMENSIONS (WITHOUT CASE):

Height: 40 mm (1.5")
Width: 72 mm (2.8")
Depth: 72 mm (2.8")

WEIGHT:

150 g (0.33 lb.) (including batteries)

Ordering Information

Type 4231: Sound Level Calibrator
includes the following accessories:
KE 0317: Leather Case
2 \times QB 0013: Alkaline Batteries Type LR6
UC 0210: Adaptor for 1/2" microphones

Optional Accessories

DE 0781: Adaptor for Noise Dose Meter Type 4436
DP 0775: Adaptor for 1/4" microphones
DP 0774: Adaptor for 1/8" microphones
DP 0682: Adaptor for Brüel & Kjær Studio Microphones Types 4003/4006

DP 0750: Adaptor for Brüel & Kjær Studio Microphones Types 4004/4007
DP 0887: Adaptor for Head and Torso Simulator Type 4128
DP 0888: Adaptor for Intensity Probe Sets
UA 1072: Adaptor for Weatherproof Microphone Unit Type 4184

* For all enquires about Brüel & Kjær Studio Microphones please contact Danish Pro Audio ApS, DK-3450 Allerød, Denmark, Tel.: (+45) 4814 2828, Fax: (+45) 4814 2700.

Chapter 6

Index

Entries marked in *Italic* are references to figures or tables.

Symbols

+ 20 dB Level Step1-3

Numerics

1/4" Microphones1-5
1/8" Microphones1-5
1" Microphones1-6
41281-5
41841-5
44361-5

A

Ambient
 Pressure3-2
 Temperature3-2
ANSI S 1.403-4

B

Batteries1-3
Brüel & Kjær
 Intensity Probe Sets1-5
 Studio Microphones1-5

C

Calibration Level Correction1-6, 2-3

Calibration Level Correction (Table)1-6
Calibration levels2-3
Construction3-7
Control Circuit3-6
Cross-section of the calibrator3-5

D

Danish Primary Laboratory of Acoustics3-4
DPLA3-4

F

Feed-back3-3, 3-5
Feed-back Circuit3-5
Frequency Reference3-6

G

Generator, Variable Amplitude Sine3-6

H

Head and Torso Simulator Type 41281-5
Helmholtz resonator3-7

I

Intensity Probe Sets1-5

Index

L			
Load Volume	3-3	Reference microphone	3-5
Long-term stability	3-4	Resonator, Helmholtz	3-7
M		S	
Microphone Characteristics	2-3	Short-term stability	3-4
Microphones	1-2	Sound field	2-3
N		Sound pressure level	1-3
National Institute of Standards and Technology	3-4	Specifications 4231	5-2
Noise Dose Meter Type 4436	1-5	SPL Reference	3-6
O		Stability	
On/Off button	1-2	Long-term	3-4
Optional Accessories	5-2	Short-term	3-4
Ordering Information	5-2	Studio Microphones	1-5
P		T	
Pressure equalization	3-7	Temperature, ambient	3-2
Pressure, ambient	3-2	Traceability	3-4
R		Type 4128	1-5
Recalibration	3-4	Type 4184	1-5
Reference		Type 4436	1-5
Frequency	3-6	V	
SPL	3-6	Variable Amplitude Sine Generator	3-6
		W	
		Weatherproof Microphone Unit Type 4184	1-5

Packing Note

Type/Partno.	Description
4231	Sound Pressure Calibrator

Partno.	Quantity	Description
DD 0511	2	Battery cover
KE 0317	1	Leathercase
QB 0013	2	Battery, alkaline 1,5V 1,5Ah

Packed and controlled by :

B. R. 71

If the accessories included specified in the Product Data Sheet or Manual differ from the items supplied, the items mentioned on the Packing Note / List are valid.

Brüel & Kjær

WORLD HEADQUARTERS: DK-2850 Nærum · Denmark

Telephone: +45 42 80 05 00 · Telex: 37316 bruka dk · Fax: +45 42 80 14 05

Australia (02) 450-2066 · Austria 0222/816 74 00 · Belgium 02-24297 45 · Brazil (011) 246-8149/246-8166
Canada (514) 695-8225 · Czech Republic 02-243104 58 · Finland (0)1481577 · France (1) 64 57 20 10
Germany 04106/7095-0 · Great Britain (081) 954-2366 · Holland 03402-39994 · Hong Kong 548 7486
Hungary (1) 215 83 05/215 89 29 · Italy (02) 57 60 4141 · Japan 03-5420-7302 · Republic of Korea (02) 554-0605
Norway 6690 44 10 · Poland (0-22) 40 93 92 · Portugal (1) 65 92 56/65 92 80 · Singapore 225 8533
Slovak Republic 07-55666 · Spain (91) 368 10 00 · Sweden (08) 71 127 30 · Switzerland (1) 862 19 60
Taiwan (02) 713 9303 · Tunisia (01) 232 478 · USA: MA (508) 481-7737 GA (404) 981-6225 MI (313) 522-860
IL (708) 358-7582 CA (714) 978-8066 WA (206) 883-2203/882-4359
Local representatives and service organisations world-wide

PRINTED IN DENMARK BY NÆRUM OFFSET