



Regione
Sicilia



Città
metropolitana
di Palermo



Provincia
di Caltanissetta



Comune di
Petralia Sottana



Comune di
Villalba



Comune di
Castellana Sicula

Impianto agrofotovoltaico "GARISI" di potenza installata pari a 57 MW da realizzarsi nel Comune di Petralia Sottana (PA)

PROGETTO DEFINITIVO

REV.	DATA	DESCRIZIONE	REDATTO	VERIFICATO	APPROVATO
00	25/11/2022	Prima Stesura	Ing. Fabiana Marchese	Dott. Giuseppe Filiberto	Ing. Carlo Gargano

PROGETTISTA:

GREEN FUTURE Srl

Sede Legale: Via U. Maddalena, 92

Sede operativa: Corso Calatafimi, 421

90100 - Palermo, Italia

info@greenfuture.it



Dott. Giuseppe Filiberto

Ing. Alessio Furlotti

Arch. Pianif. Giovanna Filiberto

Ing. Ilaria Vinci

Ing. Fabiana Marchese

Ing. Daniela Chifari

Green Future s.r.l. unipersonale
L'Amministratore
Giuseppe Filiberto



PROPONENTE:



FALCK RENEWABLES SICILIA SRL

Corso Venezia 16

20121 Milano, Italia

frsicilia@legalmail.it

TITOLO ELABORATO:

SCHEDE TECNICHE

CODICE ELABORATO:

GARISI_EL47_REV00

SCALA:

-

DATA:

Novembre 2022

TIPOLOGIA/ANNO

FV22

COD. PROGETTO

GARISI

N.º ELABORATO

EL47

REVISIONE

00

Tiger Neo N-type 78HL4-BDV 590-610 Watt

BIFACIAL MODULE WITH
DUAL GLASS

N-Type

Positive power tolerance \varnothing of 0~+3%

IEC61215(2016), IEC61730(2016)

ISO9001:2015: Quality Management System

ISO14001:2015: Environment Management System

ISO45001:2018
Occupational health and safety management systems

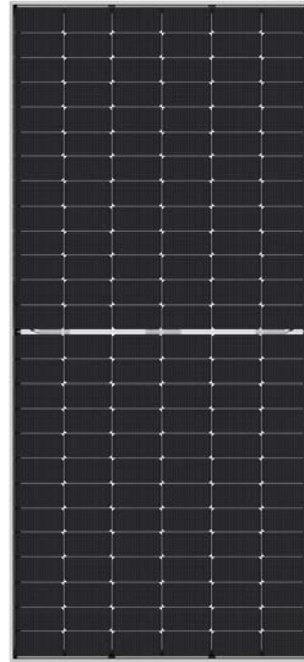

Key Features



SMBB Technology

Better light trapping and current collection to improve module power output and reliability.



PID Resistance

Excellent Anti-PID performance guarantee via optimized mass-production process and materials control.



Higher Power Output

Module power increases 5-25% generally, bringing significantly lower LCOE and higher IRR.



Hot 2.0 Technology

The N-type module with Hot 2.0 technology has better reliability and lower LID/LETID.



Enhanced Mechanical Load

Certified to withstand: wind load (2400 Pascal) and snow load (5400 Pascal).



LINEAR PERFORMANCE WARRANTY

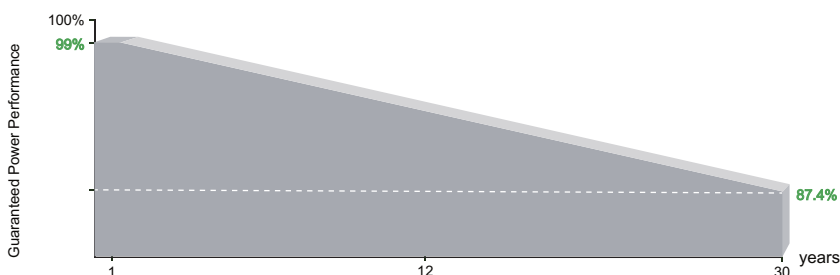

12 Year Product Warranty

30 Year Linear Power Warranty

0.40% Annual Degradation Over 30 years

Engineering Drawings

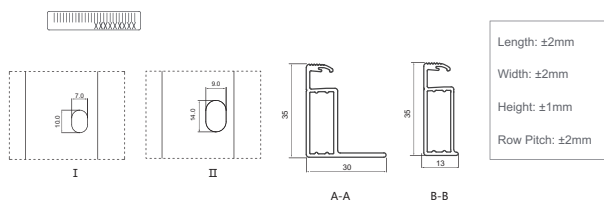
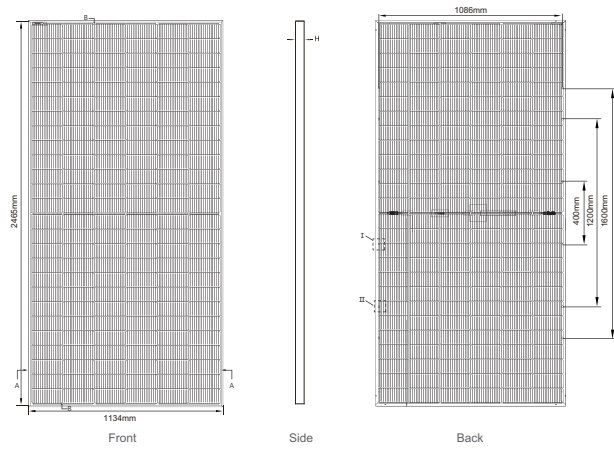

Electrical Performance & Temperature Dependence

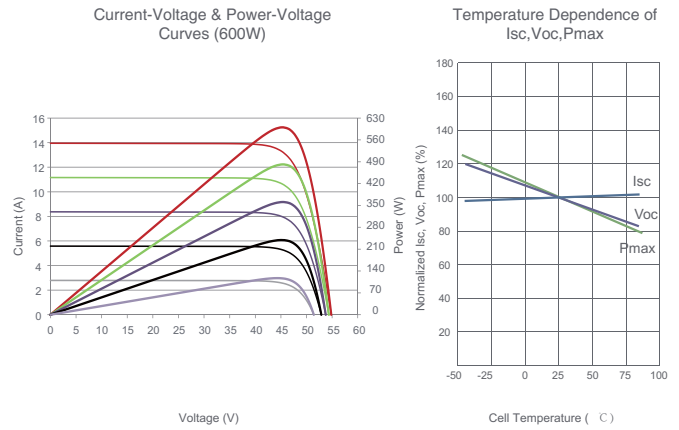

Mechanical Characteristics

Cell Type	N type Mono-crystalline
No. of cells	156 (2×78)
Dimensions	2465×1134×35mm (97.05×44.65×1.38 inch)
Weight	34.6kg (76.38 lbs)
Front Glass	2.0mm, Anti-Reflection Coating
Back Glass	2.0mm, Heat Strengthened Glass
Frame	Anodized Aluminium Alloy
Junction Box	IP68 Rated
Output Cables	TUV 1×4.0mm ² (+): 400mm, (-): 200mm or Customized Length

Packaging Configuration

(Two pallets = One stack)

31pcs/pallets, 62pcs/stack, 496pcs/ 40'HQ Container

SPECIFICATIONS

Module Type	JKM590N-78HL4-BDV		JKM595N-78HL4-BDV		JKM600N-78HL4-BDV		JKM605N-78HL4-BDV		JKM610N-78HL4-BDV	
	STC	NOCT	STC	NOCT	STC	NOCT	STC	NOCT	STC	NOCT
Maximum Power (Pmax)	590Wp	444Wp	595Wp	447Wp	600Wp	451Wp	605Wp	455Wp	610Wp	459Wp
Maximum Power Voltage (Vmp)	44.91V	41.89V	45.08V	42.00V	45.25V	42.12V	45.42V	42.23V	45.60V	42.35V
Maximum Power Current (Imp)	13.14A	10.59A	13.20A	10.65A	13.26A	10.71A	13.32A	10.77A	13.38A	10.83A
Open-circuit Voltage (Voc)	54.76V	52.02V	54.90V	52.15V	55.03V	52.27V	55.17V	52.41V	55.31V	52.54V
Short-circuit Current (Isc)	13.71A	11.07A	13.79A	11.13A	13.87A	11.20A	13.95A	11.26A	14.03A	11.33A
Module Efficiency STC (%)	21.11%		21.29%		21.46%		21.64%		21.82%	
Operating Temperature(°C)	-40°C~+85°C									
Maximum system voltage	1500VDC (IEC)									
Maximum series fuse rating	30A									
Power tolerance	0~+3%									
Temperature coefficients of Pmax	-0.30%/°C									
Temperature coefficients of Voc	-0.25%/°C									
Temperature coefficients of Isc	0.046%/°C									
Nominal operating cell temperature (NOCT)	45±2°C									
Refer. Bifacial Factor	80±5%									

BIFACIAL OUTPUT-REAR SIDE POWER GAIN

		5%		15%		25%	
		Maximum Power (Pmax)	Module Efficiency STC (%)	Maximum Power (Pmax)	Module Efficiency STC (%)	Maximum Power (Pmax)	Module Efficiency STC (%)
		620Wp	22.16%	679Wp	24.27%	738Wp	26.38%
		625Wp	22.35%	684Wp	24.48%	744Wp	26.61%
		630Wp	22.54%	690Wp	24.68%	750Wp	26.83%
		635Wp	22.73%	696Wp	24.89%	756Wp	27.05%
		641Wp	22.91%	702Wp	25.10%	763Wp	27.28%

*STC Irradiance 1000W/m² Cell Temperature 25°C

NOCT: Irradiance 800W/m² Ambient Temperature 20°C

AM=1.5

AM=1.5

Wind Speed 1m/s

**TRANSFORMERLESS
DUAL SOLUTION
WITH TWO B SERIES
INVERTERS****Up to 3.6 MVA at 1500 V****Maximum power density**

These PV central inverters feature more power per cubic foot. Thanks to the use of high-quality components, this inverter series performs at the highest possible level.

Latest generation electronics

The B Series inverters integrate an innovative control unit that runs faster and performs a more efficient and sophisticated inverter control, as it uses a last-generation digital signal processor. Furthermore, the hardware of the control unit allows some more accurate measurements and very reliable protections.

These inverters feature a low voltage ride-through capability and also a lower power consumption thanks to a more efficient power supply electronic board.

Integrated AC connections

The output connections are integrated into the same cabinet, facilitating close-coupled connection with the MV transformer, as well as maintenance and repair work.

Maximum protection

These PV inverters can guarantee the maximum protection thanks to their motorized DC switch to decouple the PV generator from the inverter.

Moreover, they are also supplied with a motorized AC circuit breaker. Optionally, they can be supplied with DC fuses, grounding kit and input current monitoring.

Maximum efficiency values

Through the use of innovative electronic conversion topologies, efficiency values of up to 98.9% can be achieved.

Enhanced functionality

This new INGECON® SUN Power range features a revamped, improved enclosure which, together with its innovative air cooling system, makes it possible to increase the ambient operating temperature.



Long-lasting design

These inverters have been designed to guarantee a long life expectancy. Standard 5 year warranty, extendable for up to 25 years.

Grid support

The INGECON® SUN Power B Series has been designed to comply with the grid connection requirements, contributing to the quality and stability of the electric system. These inverters therefore feature a low voltage ride-through capability, and can deliver reactive power and control the active power delivered to the grid. Moreover, they can operate in weak power grids with a low SCR.

Ease of maintenance

All the elements can be removed or replaced directly from the inverter's front side, thanks to its new design.

Easy to operate

The INGECON® SUN Power inverters feature an LCD screen for the simple and convenient monitoring of the inverter status and a range of internal variables. The display also includes a number of LEDs to show the inverter operating status with warning lights to indicate any incidents. All this helps to simplify and facilitate maintenance tasks.

Monitoring and communication

Ethernet communications supplied as standard. The following applications are included at no extra cost: INGECON® SUN Manager, INGECON® SUN Monitor and its Smartphone version Web Monitor, available on the App Store. These applications are used for monitoring and recording the inverter's internal operating variables through the Internet (alarms, real time production, etc.), in addition to the historical production data.

Two communication ports available for each inverter (one for monitoring and one for plant controlling), allowing fast and simultaneous plant control.

PROTECTIONS

- DC Reverse polarity.
- Short-circuits and overloads at the output.
- Anti-islanding with automatic disconnection.
- Insulation failure DC.
- Up to 15 pairs of fuse-holders per power block.
- Lightning induced DC and AC surge arresters, type II.
- Motorized DC switch to automatically disconnect the inverter from the PV array.
- Low voltage ride-through capability.
- Motorized AC circuit breaker.
- Hardware protection via firmware.
- Additional protection for the power stack, as it is air-cooled by a closed loop.

OPTIONAL ACCESSORIES

- Auxiliary services feeder.
- Grounding kit.
- Heating kit, for operating at an ambient temperature of down to -30 °C.
- DC surge arresters type I+II.
- DC fuses.
- Monitoring of the group currents at the DC input.
- PID prevention kit (PID: Potential Induced Degradation).
- Night time reactive power injection.
- Sand trap kit.
- Integrated DC combiner box.

ADVANTAGES OF THE B SERIES

- Higher power density.
- Latest generation electronics.
- More efficient electronic protection.
- Night time supply to communicate with the inverter at night.
- Enhanced performance.
- Easier maintenance thanks to its new design and enclosure.
- Lightweight spares.
- It allows to ground the PV array.
- Components easily replaceable.

Power B Series

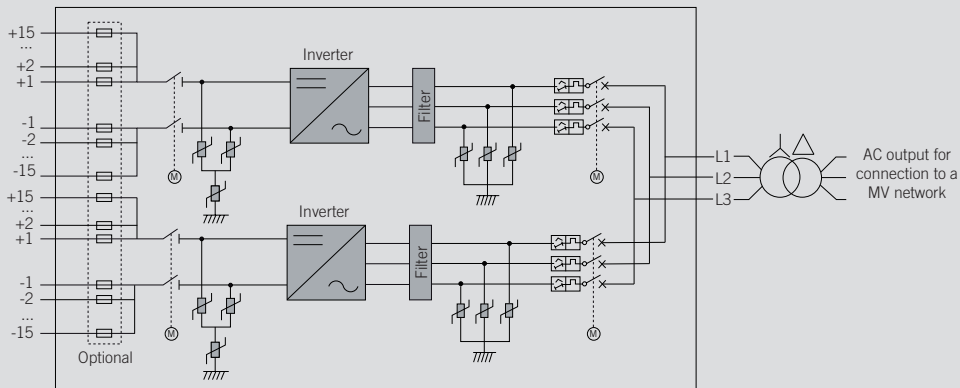

Size and weight (mm and kg)

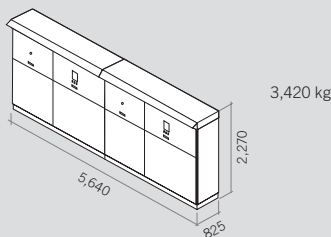

Efficiency DUAL INGECON® SUN 1690TL B650

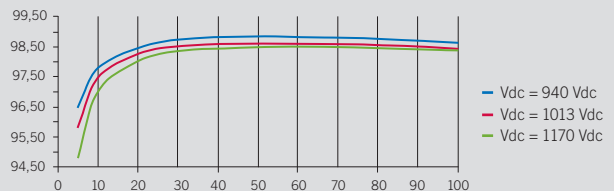

	2340 kVA DUAL INGECON® SUN 1170TL B450	2800 kVA DUAL INGECON® SUN 1400TL B540	3000 kVA DUAL INGECON® SUN 1500TL B578	3120 kVA DUAL INGECON® SUN 1560TL B600	3200 kVA DUAL INGECON® SUN 1600TL B615
Input (DC)					
Recommended PV array power range ⁽¹⁾	2,314 - 3,040 kWp	2,778 - 3,648 kWp	2,974 - 3,904 kWp	3,086 - 4,052 kWp	3,164 - 4,154 kWp
Voltage Range MPP ⁽²⁾	645 - 1,300 V	769 - 1,300 V	822 - 1,300 V	853 - 1,300 V	873 - 1,300 V
Maximum voltage ⁽³⁾	1,500 V				
Maximum current	1,870 A per power block				
N° inputs with fuse-holders	6 up to 15 per power block (up to 12 with the combiner box)				
Fuse dimensions	63 A / 1,500 V to 500 A / 1,500 V fuses (optional)				
Type of connection	Connection to copper bars				
Power blocks	2				
MPPT	2				
Input protections					
Overvoltage protections	Type II surge arresters (type I+II optional)				
DC switch	Motorized DC load break disconnect				
Other protections	Up to 15 pairs of DC fuses (optional) / Reverse polarity / Insulation failure monitoring / Anti-islanding protection / Emergency pushbutton				
Output (AC)					
Power IP54 @30 °C / @50 °C	2,338 kVA / 2,104 kVA	2,806 kVA / 2,525 kVA	3,004 kVA / 2,703 kVA	3,118 kVA / 2,806 kVA	3,196 kVA / 2,876 kVA
Current IP54 @30 °C / @50 °C	3,000 A / 2,700 A				
Power IP56 @27 °C / @50 °C ⁽⁴⁾	2,338 kVA / 2,070 kVA	2,806 kVA / 2,484 kVA	3,004 kVA / 2,660 kVA	3,118 kVA / 2,760 kVA	3,196 kVA / 2,830 kVA
Current IP56 @27 °C / @50 °C ⁽⁴⁾	3,000 A / 2,656 A				
Rated voltage ⁽⁵⁾	450 V IT System	540 V IT System	578 V IT System	600 V IT System	615 V IT System
Frequency	50 / 60 Hz				
Power Factor adjustable	0-1 (leading / lagging)				
THD (Total Harmonic Distortion) ⁽⁶⁾	<3%				
Output protections					
Overvoltage protections	Type II surge arresters				
AC breaker	Motorized AC circuit breaker with door control				
Anti-islanding protection	Yes, with automatic disconnection				
Other protections	AC short-circuits and overloads				
Features					
Operating efficiency	98.9%				
CEC	98.5%				
Max. consumption aux. services	9,400 W (50 A)				
Stand-by or night consumption ⁽⁷⁾	< 180 W				
Average power consumption per day	4,000 W				
General Information					
PV inverters included	Two units of the INGECON® SUN 1170TL B450	Two units of the INGECON® SUN 1400 B450	Two units of the INGECON® SUN 1500TL B578	Two units of the INGECON® SUN 1560TL B600	Two units of the INGECON® SUN 1600TL B615
Ambient temperature	-20 °C to +57 °C				
Relative humidity (non-condensing)	0-100% (Outdoor)				
Protection class	IP54 (IP56 with the sand trap kit)				
Corrosion protection	External corrosion protection				
Maximum altitude	4,500 m (for installations beyond 1,000 m, please contact Ingeteam's solar sales department)				
Cooling system	Air forced with temperature control (230 V phase+ neutral power supply)				
Air flow range	0 - 7,800 m³/h per power block				
Average air flow	2 x 4,200 m³/h				
Acoustic emission (100% / 50% load)	<66 dB(A) at 10m / <54.5 dB(A) at 10m				
Marking	CE				
EMC and security standards	IEC 62920, IEC 61000-6-1, IEC 61000-6-2, IEC 61000-6-4, IEC 61000-3-11, IEC 61000-3-12, IEC 62109-1, IEC 62109-2, EN 50178, FCC Part 15, AS3100				
Grid connection standards	IEC 62116, EN 50530, IEC 61683, EU 631/2016 (EN 50549-2, P.O.12.2, CEI 0-16, VDE AR N 4120 ...), G99, South African Grid code, Mexican Grid Code, Chilean Grid Code, Ecuadorian Grid Code, Peruvian Grid code, Thailand PEA requirements, IEC61727, UNE 206007-1, ABNT NBR 16149, ABNT NBR 16150, IEEE 1547, IEEE1547.1, DEWA (Dubai) Grid code, Abu Dhabi Grid Code, Jordan Grid Code, Egyptian Grid Code, Saudi Arabia Grid Code, RETIE Colombia, Australian Grid Code				

Notes: ⁽¹⁾ Depending on the type of installation and geographical location. Data for STC conditions ⁽²⁾ V_{mpp}.min is for rated conditions (V_{ac}=1 p.u. and Power Factor=1) and floating systems ⁽³⁾ Consider the voltage increase of the 'Voc' at low temperatures ⁽⁴⁾ With the sand trap kit ⁽⁵⁾ Other AC voltages and powers available upon request ⁽⁶⁾ For P_{out}>25% of the rated power and voltage in accordance with IEC 61000-3-4 ⁽⁷⁾ Consumption from PV field when there is PV power available.

	3280 kVA DUAL INGECON® SUN 1640TL B630	3350 kVA DUAL INGECON® SUN 1675TL B645	3430 kVA DUAL INGECON® SUN 1715TL B660	3510 kVA DUAL INGECON® SUN 1755TL B675	3600 kVA DUAL INGECON® SUN 1800TL B690
Input (DC)					
Recommended PV array power range ⁽¹⁾	3,240 - 4,256 kWp	3,318 - 4,358 kWp	3,396 - 4,458 kWp	3,472 - 4,560 kWp	3,550 - 4,662 kWp
Voltage Range MPP ⁽²⁾	894 - 1,300 V	915 - 1,300 V	935 - 1,300 V	957 - 1,300 V	978 - 1,300 V
Maximum voltage ⁽³⁾	1,500 V				
Maximum current	1,870 A per power block				
N° inputs with fuse-holders	6 up to 15 per power block (up to 12 with the combiner box)				
Fuse dimensions	63 A / 1,500 V to 500 A / 1,500 V fuses (optional)				
Type of connection	Connection to copper bars				
Power blocks	2				
MPPT	2				
Input protections					
Overvoltage protections	Type II surge arresters (type I+II optional)				
DC switch	Motorized DC load break disconnect				
Other protections	Up to 15 pairs of DC fuses (optional) / Reverse polarity / Insulation failure monitoring / Anti-islanding protection / Emergency pushbutton				
Output (AC)					
Power IP54 @30 °C / @50 °C	3,274 kVA / 2,946 kVA	3,352 kVA / 3,016 kVA	3,430 kVA / 3,086 kVA	3,508 kVA / 3,156 kVA	3,586 kVA / 3,226 kVA
Current IP54 @30 °C / @50 °C	3,000 A / 2,700 A				
Power IP56 @27°C / @50°C ⁽⁴⁾	3,274 kVA / 2,898 kVA	3,352 kVA / 2,967 kVA	3,430 kVA / 3,036 kVA	3,508 kVA / 3,105 kVA	3,586 kVA / 3,174 kVA
Current IP56 @27°C / @50°C ⁽⁴⁾	3,000 A / 2,656 A				
Rated voltage ⁽⁵⁾	630 V IT System	645 V IT System	660 V IT System	675 V IT System	690 V IT System
Frequency	50 / 60 Hz				
Power Factor adjustable	0-1 (leading / lagging)				
THD (Total Harmonic Distortion) ⁽⁶⁾	<3%				
Output protections					
Overvoltage protections	Type II surge arresters				
AC breaker	Motorized AC circuit breaker with door control				
Anti-islanding protection	Yes, with automatic disconnection				
Other protections	AC short-circuits and overloads				
Features					
Operating efficiency	98.9%				
CEC	98.5%				
Max. consumption aux. services	9,400 W (50 A)				
Stand-by or night consumption ⁽⁷⁾	< 180 W				
Average power consumption per day	4,000 W				
General Information					
PV inverters included	Two units of the INGECON® SUN 1640TL B630	Two units of the INGECON® SUN 1665TL B640	Two units of the INGECON® SUN 1690TL B650	Two units of the INGECON® SUN 1740TL B670	Two units of the INGECON® SUN 1800TL B690
Ambient temperature	-20 °C to +57 °C				
Relative humidity (non-condensing)	0-100% (Outdoor)				
Protection class	IP54 (IP56 with the sand trap kit)				
Corrosion protection	External corrosion protection				
Maximum altitude	4,500 m (for installations beyond 1,000 m, please contact Ingeteam's solar sales department)				
Cooling system	Air forced with temperature control (230 V phase+ neutral power supply)				
Air flow range	0 - 7,800 m³/h per power block				
Average air flow	2 x 4,200 m³/h				
Acoustic emission (100% / 50% load)	<66 dB(A) at 10m / <54.5 dB(A) at 10m				
Marking	CE				
EMC and security standards	IEC 62920, IEC 61000-6-1, IEC 61000-6-2, IEC 61000-6-4, IEC 61000-3-11, IEC 61000-3-12, IEC 62109-1, IEC 62109-2, EN 50178, FCC Part 15, AS3100				
Grid connection standards	IEC 62116, EN 50530, IEC 61683, EU 631/2016 (EN 50549-2, P.O.12.2, CEI 0-16, VDE AR N 4120 ...), G99, South African Grid code, Mexican Grid Code, Chilean Grid Code, Ecuadorian Grid Code, Peruvian Grid code, Thailand PEA requirements, IEC61727, UNE 206007-1, ABNT NBR 16149, ABNT NBR 16150, IEE 1547, IEEE1547.1, DEWA (Dubai) Grid code, Abu Dhabi Grid Code, Jordan Grid Code, Egyptian Grid Code, Saudi Arabia Grid Code, RETIE Colombia, Australian Grid Code				

Notes: ⁽¹⁾ Depending on the type of installation and geographical location. Data for STC conditions ⁽²⁾ V_{mpp}.min is for rated conditions (V_{ac}=1 p.u. and Power Factor=1) and floating systems ⁽³⁾ Consider the voltage increase of the 'Voc' at low temperatures ⁽⁴⁾ With the sand trap kit ⁽⁵⁾ Other AC voltages and powers available upon request ⁽⁶⁾ For P_{out}>25% of the rated power and voltage in accordance with IEC 61000-3-4 ⁽⁷⁾ Consumption from PV field when there is PV power available.

**MEDIUM VOLTAGE
POWER STATION,
CUSTOMIZED
UP TO 7.2 MVA,
WITH ALL THE
COMPONENTS
SUPPLIED ON TOP
OF A FULL SKID**

From 1.17 to 7.2 MVA

This brand new medium voltage solution integrates all the devices required for a multi-mega-watt system.

Maximize your investment with a minimal effort

Ingeteam's Power Station is a compact, customizable and flexible solution that can be configured to suit each customer's requirements. It is supplied together with up to four photovoltaic inverters (two dual inverters). All the equipment is suitable for outdoor installation, so there is no need of any kind of housing.

Higher adaptability and power density

This PowerStation is now more versatile, as it presents the MV transformer integrated into a steel base frame together with the LV and MV components, including the PV inverters. Moreover, it features a great power density: 317 kW/m³.

Plug & Play technology

This MV solution integrates power conversion equipment (up to 7.2 MVA), liquid-filled hermetically sealed transformer up to 36 kV and provision for low voltage equipment.

The MV Skid is delivered pre-assembled for a fast on-site connection with up to two dual PV inverters from Ingeteam's B Series central inverter family.

Complete accessibility

Thanks to the lack of housing, the inverters, the switchgear and the transformer can have immediate access. Furthermore, the design of the B Series central inverters has been conceived to facilitate maintenance and repair works.

Maximum protection

Ingeteam's B Series central inverters integrate the latest generation electronics and a much more efficient electronic protection. Apart from that, they feature the main electrical protections and they deploy grid support functionalities, such as low voltage ride-through capability, reactive power deliverance and active power injection control.

Furthermore, the electrical connection between the inverters and the transformer is fully protected from direct contact.

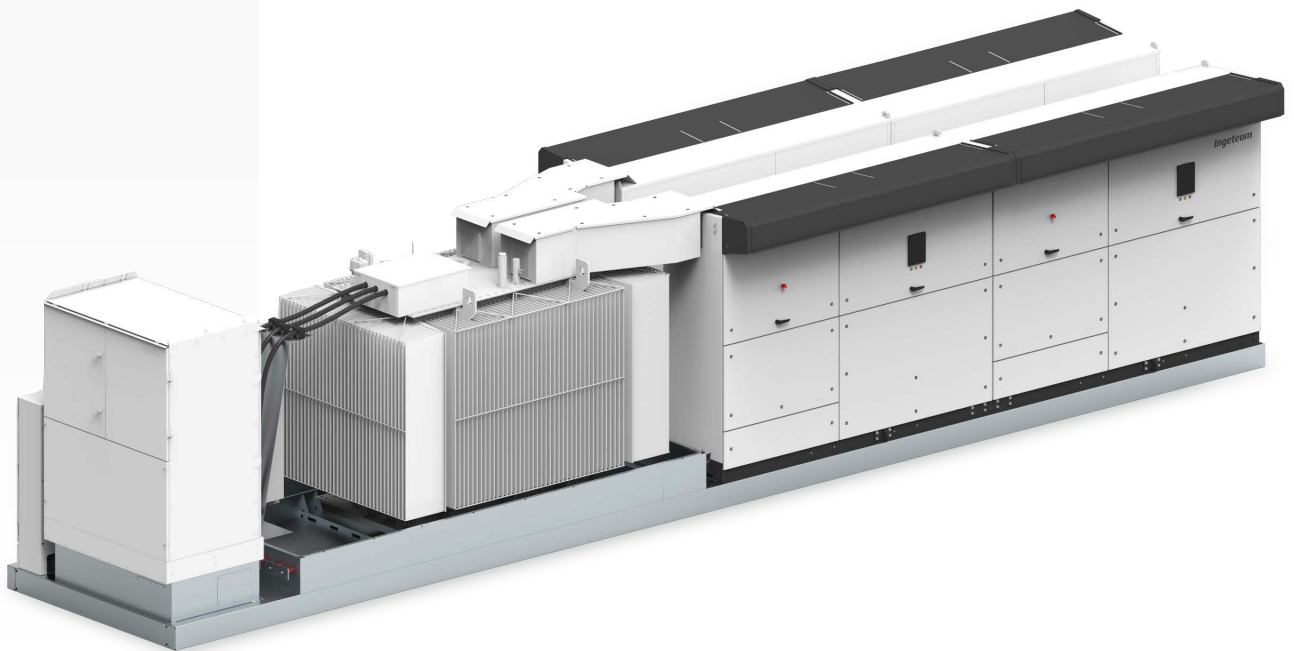

CONSTRUCTION

- Steel base frame.
- Suitable for slab or piers mounting.
- Compact design, minimizing freight costs.

OPTIONAL ACCESSORIES

- Auxiliary services transformer (up to 50 kVA, Dyn11).
- UPS for monitoring (1.5 kVA, 30 min).
- LV Surge arresters type I+II.
- MV Surge arresters.
- Low voltage distribution panel (IP55).
- Power plant commissioning.
- High-speed Ethernet / fibre optic communication infrastructure for Plug & Play connection to the Power Plant Controller and/or SCADA systems.
- INGECON® SUN StringBox with 16 / 24 / 32 input channels. Intelligent or passive string combiner box.
- Energy meter for auxiliary services and/or energy production.
- Insulation monitoring relay for continuous monitoring of IS systems insulation.
- Reactive power regulation when there is no PV power available.
- Ground connection of the PV array.

STANDARD EQUIPMENT

- Up to four inverters with an output power of 7.2 MVA.
- Liquid-filled hermetically sealed transformer up to 36 kV.
- 1L1A MV switchgear (2L1A optional).
- Oil-retention tank.
- Frame for installation of LV equipment.
- Minimum installation at project site.

COMPONENTS

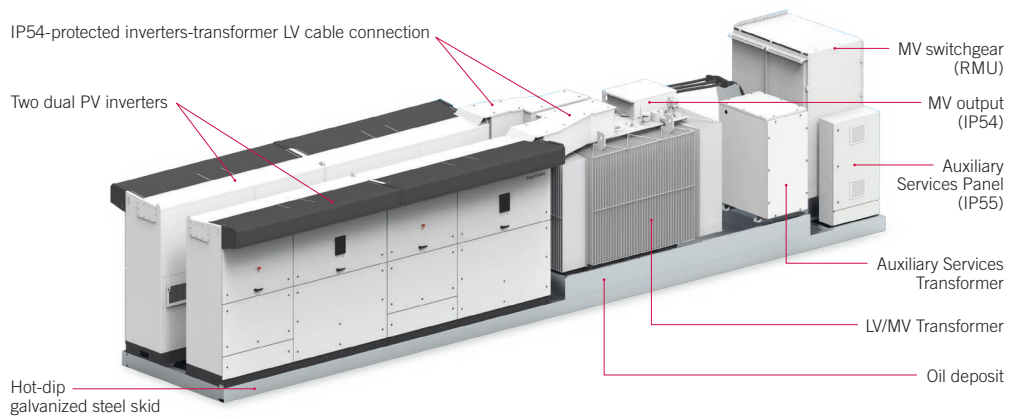

PV PLANT CONFIGURATION

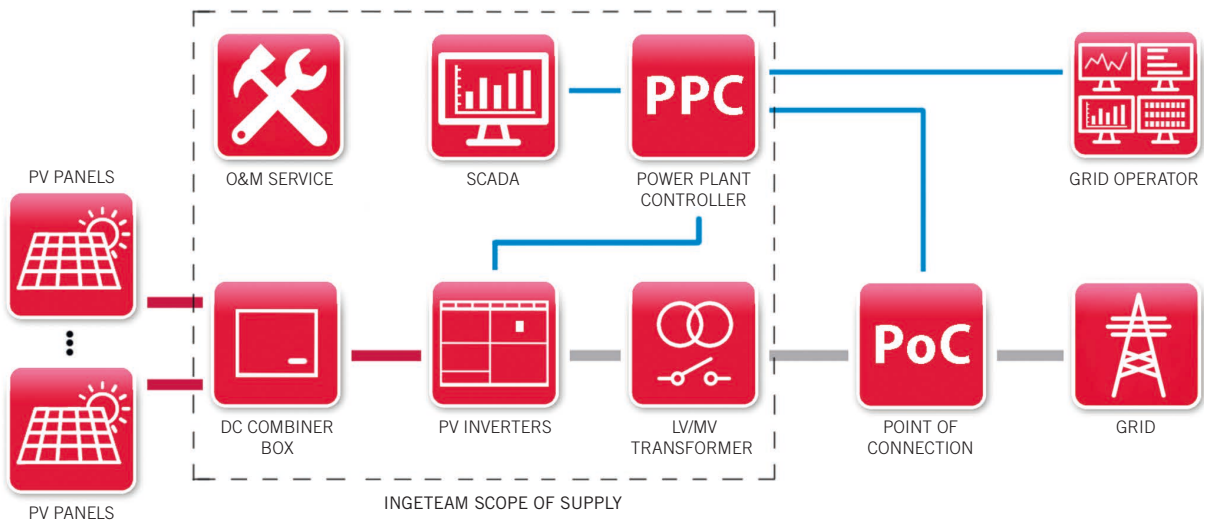

	1800 FSK B Series	3600 FSK B Series	5400 FSK B Series	7200 FSK B Series
General data				
Number of inverters	1	2	3	4
Max. power @30 °C / 86 °F ⁽¹⁾	1,793 kVA	3,586 kVA	5,379 kVA	7,172 kVA
Operating temperature range	from -20 °C to +50 °C			
Relative humidity (non-condensing)	0 - 100%			
Maximum altitude	3,000 masl (power derating starting at 1,000 masl)			
LV / MV Transformer				
Medium voltage	From 20 kV up to 36 kV, 50-60 Hz			
Cooling system	ONAN			
Minimum PEI (Peak Efficiency Index) ⁽²⁾	99.40%			
Protection degree	IP54			
MV Switchgear				
Medium voltage	24 kV / 36 kV / 40.5 kV			
Rated current	630 A			
Cooling system	Natural air ventilation			
Protection degree	IP54			
Equipment				
LV-AUX Switchgear	Standard version (optional monitoring system)			
LV / MV Transformer	Oil-immersed hermetically sealed transformer			
MV Switchgear	1L1A cells (2L1A optional)			
Mechanical information				
Structure type	Hot dip galvanized steel skid			
Dimensions Full Skid (W x D x H)	8,570 x 2,100 x 2,460 mm	11,390 x 2,100 x 2,460 mm	11,390 x 2,100 x 2,460 mm	11,390 x 2,100 x 2,460 mm
Full Skid	13 T	16 T	19 T	25 T
Standards	IEC 62271-212, IEC 62271-200, IEC 60076, IEC 61439-1			

Notes: ⁽¹⁾ Maximum power calculated with the inverter model INGECON® SUN 1800TL B690. For other inverter models, please contact Ingeteam's Solar sales department ⁽²⁾ For European installations, ECO design according to the EU 548/2014 and EU 2019/1783 standards.

Configuration with four B Series PV inverters

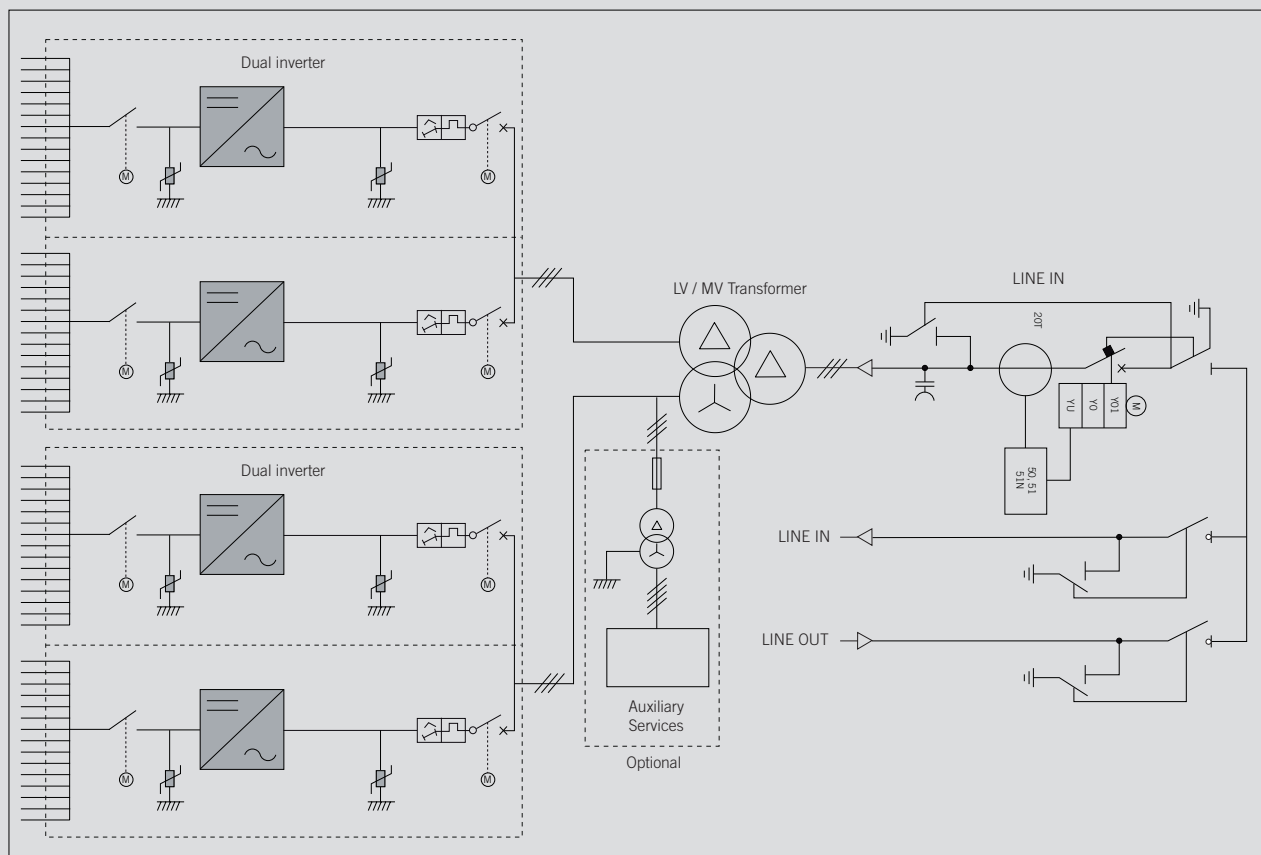

Ingeteam

Ingeteam Power Technology, S.A.
Avda. Ciudad de la Innovación, 13
31621 Sarriguren (Navarra) - Spain
Tel.: +34 948 288 000
Fax: +34 948 288 001
e-mail: solar.energy@ingeteam.com

Ingeteam S.r.l.
Via Emilia Ponente, 232
48014 Castel Bolognese (RA) - Italy
Tel.: +39 0546 651 490
Fax: +39 054 665 5391
e-mail: italia.energy@ingeteam.com

Ingeteam SAS
La Naurouze B - 140 rue Carmin
31670 Labège - France
Tel.: +33 (0)5 61 25 00 00
Fax: +33 (0)5 61 25 00 11
e-mail: france@ingeteam.com

Ingeteam INC.
3550 W. Canal St.
Milwaukee, WI 53208 - USA
Tel.: +1 (414) 934 4100 / +1 (855) 821 7190
Fax: +1 (414) 342 0736
e-mail: solar.us@ingeteam.com

Ingeteam, a.s.
Technologická 371/1
70800 Ostrava - Pustkovec
Czech Republic
Tel.: +420 59 747 6800
Fax: +420 59 732 6899
e-mail: czech@ingeteam.com

Ingeteam Shanghai, Co. Ltd.
Shanghai Trade Square, 1105
188 Si Ping Road
200086 Shanghai - P.R. China
Tel.: +86 21 65 07 76 36
Fax: +86 21 65 07 76 38
e-mail: shanghai@ingeteam.com

Ingeteam, S.A. de C.V.
Leibnitz Ext 13 Int 1102, Colonia Anzures
11590 - Miguel Hidalgo
Ciudad de México - Mexico
Tel.: +52 81 8311 4858
Fax: +52 81 8311 4859
e-mail: northamerica@ingeteam.com

Ingeteam Ltda.
Rua Estácio de Sá, 560
Jd. Santa Genebra
13080-010 Campinas/SP - Brazil
Tel.: +55 19 3037 3773
e-mail: brazil@ingeteam.com

Ingeteam Pty Ltd.
Unit 2 Alphen Square South
16th Road, Randjiespark
Midrand 1682 - South Africa
Tel.: +2711 314 3190
Fax: +2711 314 2420
e-mail: southafrica@ingeteam.com

Ingeteam SpA
Los militares 5890, Torre A, oficina 401
7560742 - Las Condes
Santiago de Chile - Chile
Tel.: +56 2 29574531
e-mail: chile@ingeteam.com

Ingeteam Power Technology India Pvt. Ltd.
2nd Floor, 431
Udyog Vihar, Phase III
122016 Gurgaon (Haryana) - India
Tel.: +91 124 420 6491-5
Fax: +91 124 420 6493
e-mail: india@ingeteam.com

Ingeteam Sp. z o.o.
Ul. Koszykowa 60/62 m 39
00-673 Warszawa - Poland
Tel.: +48 22 821 9930
Fax: +48 22 821 9931
e-mail: polska@ingeteam.com

Ingeteam Australia Pty Ltd.
iAccelerate Centre, Building 239
Innovation Campus, Squires Way
North Wollongong, NSW 2500 - Australia
Tel.: +61 429 111 190
e-mail: australia@ingeteam.com

Ingeteam Panama S.A.
Av. Manuel Espinosa Batista,
Ed. Torre Internacional
Business Center, Apto./Local 407
Urb.C45 Bella Vista
Bella Vista - Panama
Tel.: +50 761 329 467

Ingeteam Service S.R.L.
Bucuresti, Sector 2,
Bulevardul Dimitrie Pompeiu Nr 5-7
Cladirea Hermes Business
Campus 1, Birou 236, Etaj 2
Romania
Tel.: +40 728 993 202

Ingeteam Philippines Inc.
Office 2, Unit 330, Milelong Bldg.
Amorsolo St. corner Rufino St.
1230 Makati
Gran Manila - Philippines
Tel.: +63 0917 677 6039

Ingeteam Power Technology, S.A.
Level 1, Al Bateen Tower C6 Bainunah
ADIB Building, Street 34
PO BOX 30010 - Abu Dhabi
United Arab Emirates
Tel.: +971 50 125 8244

Ingeteam Vietnam Ltd.
Spaces - 28A Tran Hung Dao Street
Phan Chu Trinh Ward
Hoan Kiem District
Ha Noi City - Vietnam
Tel.: +84 24 71014057
e-mail: vietnam@ingeteam.com

Ingeteam Uruguay, S.A.
Avenida 18 de Julio, 1474, Piso 12
11200, Montevideo - Uruguay
Tel.: +598 934 92064

SIEMENS



Catalog
HA 40.3 ·
Edition 2017

Switchgear Type 8DJH 36 for Secondary Distribution Systems up to 36 kV, Gas-Insulated

Medium-Voltage Switchgear

[siemens.com/8DJH36](https://www.siemens.com/8DJH36)

Application

Typical uses

R-HA40-134.tif



R-HA40-112.tif



Application
in public
and industrial
energy systems

R_HA40-150a.tif

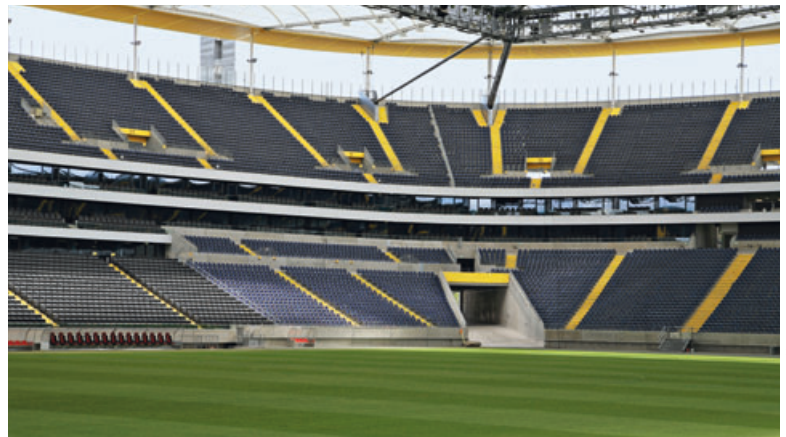

R-HA40-147.tif

R-HA40-135.tif



R-HA40-148.tif

Switchgear Type 8DJH 36 for Secondary Distribution Systems up to 36 kV, Gas-Insulated

Medium-Voltage Switchgear

Catalog HA 40.3 · 2017

Invalid: Catalog HA 40.3 · 2014

[siemens.com/medium-voltage-switchgear](https://www.siemens.com/medium-voltage-switchgear)
[siemens.com/8DJH36](https://www.siemens.com/8DJH36)

The products and systems described in this catalog are manufactured and sold according to a certified management system (acc. to ISO 9001, ISO 14001 and BS OHSAS 18001).

Application	
Typical uses	2
Types, ratings	4 and 5
Requirements	
Features, safety	6
Technology	7
Technical Data	
Electrical data of the switchgear, classification	8
Switching capacity and classification of switching devices	9 and 10
Product Range	
Individual panels and modules	11
Air-insulated billing metering panel	12
Product range overview of panel blocks	13
Design	
Panel design	14 to 16
Outdoor enclosure	17
Operation	18
Components	
Three-position switch-disconnector	19 and 20
Vacuum circuit-breaker	21 to 23
Busbar extension, modularity	24
HV HRC fuse assembly	25 to 27
Current and voltage transformers	28 to 30
Current and voltage sensors	31 and 32
Cable connection, cable testing	33 to 38
Interlocks, locking devices	39
Indicating and measuring equipment	40 to 48
Transformer monitor system, protection systems	49 and 50
Intelligent transformer substation	51 and 52
Low-voltage compartment	53
Dimensions	
Room planning	54 and 55
Individual panels and modules, billing metering panel as individual panel, panel blocks	56 to 58
Outdoor enclosure	59
Floor openings and fixing points	60 to 62
Installation	
Shipping data, transport	63 and 64
Standards	
Standards, specifications, guidelines	65 to 67

Application Types



Ring-main panel and circuit-breaker panel
as individual panels



RRT block

8DJH 36 switchgear is a factory-assembled, type-tested, 3-pole metal-enclosed single-busbar switchgear for indoor installation.

8DJH 36 switchgear is used in public and industrial energy systems of the secondary distribution level, e.g. in

- Local ring-main units, customer transfer substations and switching substations of power supply and public utilities
- Wind power plants and solar plants, hydroelectric power stations
- Water and liquid waste processing systems
- Airports, train stations, underground stations
- High-rise buildings.

Electrical data (maximum values) and dimensions

Rated voltage	kV	36
Rated frequency	Hz	50 / 60
Rated short-duration power-frequency withstand voltage	kV	70
Rated lightning impulse withstand voltage	kV	170
Rated peak withstand current	kA	50 / 52
Rated short-circuit making current	kA	50 / 52
Rated short-time withstand current 3 s	kA	20
Rated normal current of the busbar	A	630
Rated normal current of the feeders	A	200 / 630
Width		
– Ring-main feeder	mm	430
– Transformer feeder	mm	500
– Circuit-breaker feeder	mm	590
– Metering panel	mm	1100
Depth		
– Without pressure relief duct	mm	920 ¹⁾
– With pressure relief duct	mm	1035 ¹⁾
Height		
– Standard	mm	1600
– With low-voltage compartment	mm	1800 / 2000 / 2200

1) In circuit-breaker feeders, the depth in the area of the front operating mechanism of the circuit-breaker is increased by 60 mm. In metering panels, the depth is increased by 60 mm.

Requirements

Features

Environmental independence

Hermetically tight, welded switchgear vessels made of stainless steel as well as single-pole solid insulation make the parts of the primary circuit under high voltage of 8DJH 36 switchgear

- Insensitive to certain aggressive ambient conditions, such as:
 - Saline air
 - Humidity
 - Dust
 - Condensation
- Tight to ingress of foreign objects, such as:
 - Dust
 - Pollution
 - Small animals
 - Humidity.

Compact design

Thanks to the use of SF₆ insulation, compact dimensions are possible.

Thus:

- Existing switchgear rooms and substation rooms can be used effectively
- New constructions cost little
- Costly city-area space is saved.

Maintenance-free design

Switchgear vessels designed as sealed pressure systems, maintenance-free switching devices and enclosed cable plugs ensure:

- Maximum supply reliability
- Personnel safety
- Sealed-for-life design according to IEC 62271-200 (sealed pressure system)
- Installation, operation, extension and replacement without SF₆ gas work
- Reduced operating costs
- Cost-efficient investment
- No maintenance cycles.

Innovation

The use of digital secondary systems and combined protection and control devices ensures:

- Clear integration in process control systems
- Flexible and highly simplified adaptation to new system conditions and thus to cost-efficient operation.

Service life

Under normal operating conditions, the expected service life of gas-insulated switchgear 8DJH 36 is at least 35 years, probably 40 to 50 years, taking the tightness of the hermetically welded switchgear vessel into account. The service life is limited by the maximum number of operating cycles of the switchgear devices installed:

- For circuit-breakers, according to the endurance class defined in IEC 62271-100
- For three-position disconnectors and earthing switches, according to the endurance class defined in IEC 62271-102
- For three-position switch-disconnectors and earthing switches, according to the endurance class defined in IEC 62271-103.

Safety

Personal safety

- Safe-to-touch and hermetically sealed primary enclosure
- Standard degree of protection IP 65 for all high-voltage parts of the primary circuit, at least IP 2X for the switchgear enclosure according to IEC 60529 and VDE 0470-1
- Cable terminations, busbars and voltage transformers are surrounded by earthed layers in all feeders except for the air-insulated metering panels. All high-voltage parts including the cable terminations, busbars and voltage transformers are metal-enclosed
- Operating mechanisms and auxiliary switches safely accessible outside the primary enclosure (switchgear vessel)
- High resistance to internal arcs by logical mechanical interlocks and tested switchgear enclosure
- Panels tested for resistance to internal faults up to 20 kA
- Capacitive voltage detecting system to verify safe isolation from supply
- Due to the system design, operation is only possible with closed switchgear enclosure
- Logical mechanical interlocks prevent maloperation
- HV HRC fuses and cable sealing ends are only accessible when outgoing feeders are earthed
- Feeder earthing via make-proof earthing switches.

Security of operation

- Hermetically sealed primary enclosure independent of environmental effects (pollution, humidity and small animals)
- Maintenance-free in an indoor environment (IEC 62271-1 and VDE 0671-1)
- Operating mechanisms of switching devices accessible outside the primary enclosure (switchgear vessel)
- Metal-enclosed and plug-in inductive voltage transformers mounted outside the SF₆ switchgear vessel
- Current transformers as ring-core current transformers mounted outside the SF₆ switchgear vessel
- Complete switchgear interlocking system with logical mechanical interlocks
- Welded switchgear vessels, sealed for life
- Minimum fire load
- Type and routine-tested
- Standardized and manufactured using numerically controlled machines
- Quality assurance in accordance with DIN EN ISO 9001
- More than 500,000 switchgear panels of Siemens in operation worldwide for many years.

Reliability

- Type and routine-tested
- Standardized and manufactured using numerically controlled machines
- Quality assurance in accordance with DIN EN ISO 9001
- More than 500,000 switchgear panels of Siemens in operation worldwide for many years.

General

- Three-pole primary enclosure, metal-enclosed
- Welded switchgear vessel, made of stainless steel, with welded-in bushings for electrical connections and mechanical components
- Insulating gas SF₆ (fluorinated greenhouse gas)
- Maintenance-free components under normal ambient conditions according to IEC 62271-1 and VDE 0671-1
- Three-position switch-disconnector with load-break function and make-proof earthing function
- Vacuum circuit-breaker
- Cable connection with outside-cone plug-in system
- In ring-main, circuit-breaker and transformer feeders with bolted contact (M16)
- In transformer feeders optionally with plug-in contact
- Wall-standing or free-standing arrangement
- Cable connection access from front
- Installation and extension of existing switchgear at both ends without gas work and without modification of existing panels
- Pressure relief downwards, optionally to the rear/upwards, or via pressure relief duct and optionally with pressure absorber systems upwards.

Interlocks

- According to IEC 62271-200 and VDE 0671-200
- Logical mechanical interlocks prevent maloperation
- Logical mechanical interlocks and the constructive features of the three-position switches prevent maloperation as well as access to the cable connection of the feeders and HV HRC fuses under voltage
- Impermissible and undesired operations can be prevented by means of locking devices on the switching devices
- A detailed description of all interlocking options is available on page 39.

Insulating system

- Switchgear vessel filled with SF₆ gas
- Features of SF₆ gas:
 - Non-toxic
 - Odorless and colorless
 - Non-inflammable
 - Chemically neutral
 - Heavier than air
 - Electronegative (high-quality insulator)
 - Global Warming Potential GWP = 22,800
- Pressure of SF₆ gas in the switchgear vessel (absolute values at 20 °C):
 - Rated filling level: 150 kPa
 - Design pressure: 180 kPa
 - Design temperature of the SF₆ gas: 80 °C
 - Operating pressure of bursting disc: ≥ 300 kPa
 - Bursting pressure: ≥ 550 kPa
 - Gas leakage rate: < 0.1 % per year.

Modular design

- Individual panels and panel blocks can be lined up and extended at will – without gas work on site
- Low-voltage compartment available in 3 overall heights, wiring to the panel via plug connectors.

Panel design

- Factory-assembled, type-tested
- Metal-enclosed, with metallic partitions ¹⁾
- Hermetically tight, welded switchgear vessel made of stainless steel
- Maintenance-free
- Degree of protection
 - IP 65 for all high-voltage parts of the primary circuit in the gas-insulated panels
 - IP 2X for the switchgear enclosure
- Vacuum circuit-breaker with three-position disconnector for disconnecting and earthing
- Three-position switch-disconnector
- Cable connection with outside-cone plug-in system according to DIN EN 50181
- Wall-standing arrangement, optionally free-standing arrangement
- Installation and possible later extension of existing panels without gas work
- Replacement of instrument transformers without gas work, as they are located outside the gas compartments
- Enclosure made of sendzimir-galvanized sheet steel, front cover powder-coated in color "light basic" (SN 700)
- Low-voltage compartment removable, plug-in bus wires
- Lateral, metallic wiring ducts for control cables.

Instrument transformers

- Current transformers not subjected to dielectric stress
- Easy replacement of current transformers designed as ring-core transformers
- Metal-enclosed, plug-in voltage transformers.

Vacuum circuit-breaker

- Maintenance-free under normal ambient conditions according to IEC 62271-1 and VDE 0671-1
- No relubrication or readjustment
- Up to 10,000 operating cycles
- Vacuum-tight for life.

Secondary systems

- Customary protection, measuring and control equipment
- Option: Numerical multifunction protection relay with integrated protection, control, communication, operating and monitoring functions
- Can be integrated in process control systems.

1) Corresponds to "metal-clad" according to former standard IEC 60298

Technical Data

Electrical data of the switchgear, classification

Rated insulation level		Rated voltage U_r	kV	36
		Rated short-duration power-frequency withstand voltage U_d		
		– phase-to-phase, phase-to-earth, open contact gap	kV	70
		– across the isolating distance	kV	80
		Rated lightning impulse withstand voltage U_p		
		– phase-to-phase, phase-to-earth, open contact gap	kV	170
		– across the isolating distance	kV	195
Rated frequency f_r			Hz	50 / 60
Rated normal current I_r ²⁾		for ring-main feeders	A	630
		for circuit-breaker feeders	A	630
		for busbar	A	630
		for transformer feeders	A	200 ³⁾
50 Hz	Rated short-time withstand current I_k	for switchgear with $t_k = 3$ s	up to kA	20
	Rated peak withstand current I_p		up to kA	50
	Rated short-circuit making current I_{ma}	for ring-main feeders	up to kA	50
		for circuit-breaker feeders	kA	50
		for transformer feeders	up to kA	50
60 Hz	Rated short-time withstand current I_k	for switchgear with $t_k = 3$ s	up to kA	20
	Rated peak withstand current I_p		up to kA	52
	Rated short-circuit making current I_{ma}	for ring-main feeders	up to kA	52
			for circuit-breaker feeders	kA
		for transformer feeders	up to kA	52
Filling pressure (pressure values at 20 °C)		Rated filling level p_{re} (absolute)	kPa	150
		Minimum functional level p_{me} (absolute)	kPa	130
Ambient air temperature T ⁴⁾		Operation	standard	°C –25 to +55
		Storage / transport	standard	°C –25 to +55
			on request	°C –40 to +70
Degree of protection		for gas-filled switchgear vessel		IP65
		for switchgear enclosure		IP2X / IP3X ¹⁾
		for low-voltage compartment		IP3X / IP4X ¹⁾

8DJH 36 switchgear is classified according to IEC / EN 62271-200 / VDE 0671-200.

Design and construction

Partition class	PM (partition of metal)
Loss of service continuity category for panels or panel blocks	
– With HV HRC fuses (T)	LSC 2
– Without HV HRC fuses (R, L)	LSC 2
– Billing metering panel M, cable panel K	LSC 1
Accessibility to compartments (enclosure)	
– Busbar compartment	– Non accessible
– Switching-device compartment	– Non accessible
– Low-voltage compartment (option)	– Tool-based
– Cable compartment for panels or panel blocks	
– With HV HRC fuses (T)	– Interlock-controlled
– Without HV HRC fuses (R, L)	– Interlock-controlled
– Cable feeder only (K)	– Tool-based
– Metering panels (air-insulated) (M)	– Tool-based

Internal arc classification (option)

Designation of the internal arc classification IAC	Rated voltage 36 kV
IAC class for	
– Wall-standing arrangement	IAC A FL
– Free-standing arrangement	IAC A FLR
Type of accessibility A	Switchgear in closed electrical service location, access “for authorized personnel only” (according to IEC / EN 62271-200)
	Front
	Lateral
	Rear (for free-standing arrangement)
Arc test current	Up to 20 kA
Test duration	1 s

1) Design option

2) The rated normal currents apply to ambient air temperatures of max. 40 °C.

The 24-hour mean value is max. 35° C (according to IEC / EN 62271-1 / VDE 0671-1)

3) Depending on the HV HRC fuse-link

4) Minimum and maximum permissible ambient air temperature depending on the secondary equipment used

Three-position switch-disconnector

Switching capacity for general-purpose switches according to IEC/EN 62271-103/VDE 0671-103

	Rated voltage U_r	kV	36
Test duty TD _{load}	Rated mainly active	100 operations I_{load} [I_1]	A 630
	load-breaking current I_{load}	20 operations 0.05 I_{load} [I_1]	A 31.5
Test duty TD _{loop}	Rated closed-loop breaking current I_{loop} [I_{2a}]		A 630
Test duty TD _{cc}	Rated cable-charging breaking current I_{cc} [I_{4a}]		A 50
Test duty TD _{lc}	Rated line-charging breaking current I_{lc} [I_{4b}]		A 50
Test duty TD _{ma}	Rated short-circuit making current I_{ma}	50 Hz	up to kA 50
		60 Hz	up to kA 52
Test duty TD _{ef1}	Rated earth-fault breaking current TD _{ef1} [I_{6a}]		A 150
Test duty TD _{ef2}	Rated cable-charging breaking current and line-charging breaking current under earth-fault conditions I_{ef2} [former I_{6b} ($\sqrt{3} \cdot I_{4a}$ or I_{4b})]		A 87
Number of mechanical operating cycles / M-classification		n	1000 / M1 ¹⁾
Number of electrical operating cycles with I_{load} / Classification		n	100 / E3
Number of short-circuit making operations with I_{ma} / Classification		n	5 / E3
C-classification	For general-purpose switches (no restrikes, TD: I_{cc} , I_{lc})		C2

Classification for disconnectors according to IEC/EN 62271-102/VDE 0671-102

Number of mechanical operating cycles	n	1000
M-classification		M0

Switching capacity for make-proof earthing switch according to IEC/EN 62271-102/VDE 0671-102

Rated short-time withstand current I_k	50 Hz	up to kA	20
Rated short-circuit making current I_{ma}	50 Hz	up to kA	50
Rated short-time withstand current I_k	60 Hz	up to kA	20
Rated short-circuit making current I_{ma}	60 Hz	up to kA	52
Number of mechanical operating cycles / M-classification		n	1000 / M0
Number of short-circuit making operations / Classification		n	5 / E2

Switch-disconnector/fuse combination

Switch-disconnector/fuse combination

Rated voltage U_r	kV	36
Rated normal current I_r	A	200 ²⁾

Switching capacity for switch-disconnector/fuse combination according to IEC/EN 62271-105/VDE 0671-105

Rated transfer current $I_{transfer}$	A	740 ³⁾
Maximum transformer rating	kVA	2500

Switching capacity for make-proof earthing switch, feeder side, in transformer feeder with HV HRC fuses

Rated short-time withstand current I_k with $t_k = 1$ s	kA	2
Rated short-circuit making current I_{ma}	50 Hz	kA 5
	60 Hz	kA 5.2

1) Optionally 2000 operating cycles at 36 kV and 50 Hz

2) Depending on the HV HRC fuse-link

3) Up to 800 A at 36 kV and 50 Hz

Technical Data

Switching capacity and classification of switching devices

Vacuum circuit-breaker

Switching capacity according to IEC/EN 62271-100/VDE 0671-100

Type 1 with three-position disconnector

Rated voltage U_r		kV	36
Rated normal current of feeders I_r		A	630
50 Hz	Rated short-time withstand current I_k for switchgear with $t_k = 3$ s	up to kA	20
	Rated peak withstand current I_p	up to kA	50
	Rated short-circuit breaking current I_{sc}	up to kA	20
	Rated short-circuit making current I_{ma}	up to kA	50
60 Hz	Rated short-time withstand current I_k for switchgear with $t_k = 3$ s	up to kA	20
	Rated peak withstand current I_p	up to kA	52
	Rated short-circuit breaking current I_{sc}	up to kA	20
	Rated short-circuit making current I_{ma}	up to kA	52
Number of mechanical operating cycles, disconnector		n	1000
Number of mechanical operating cycles, earthing switch		n	1000
Number of mechanical operating cycles, circuit-breaker		n	10,000
Classification of circuit-breaker			M2, E2, C2
Classification of disconnector			M0
Classification of make-proof earthing switch			M0, E2
Rated operating sequence			O – 0.3 s – CO – 3 min – CO O – 0.3 s – CO – 15 s – CO on request
Number of short-circuit breaking operations		n	25 or 50

Type 2 with three-position disconnector

Rated voltage U_r		kV	36
Rated normal current of feeders I_r		A	630
50 Hz	Rated short-time withstand current I_k for switchgear with $t_k = 3$ s	up to kA	20
	Rated peak withstand current I_p	up to kA	50
	Rated short-circuit breaking current I_{sc}	up to kA	20
	Rated short-circuit making current I_{ma}	up to kA	50
60 Hz	Rated short-time withstand current I_k for switchgear with $t_k = 3$ s	up to kA	20
	Rated peak withstand current I_p	up to kA	52
	Rated short-circuit breaking current I_{sc}	up to kA	20
	Rated short-circuit making current I_{ma}	up to kA	52
Number of mechanical operating cycles, disconnector		n	1000
Number of mechanical operating cycles, earthing switch		n	1000
Number of mechanical operating cycles, circuit-breaker		n	2000
Classification of circuit-breaker			M1, E2, C2
Classification of disconnector			M0
Classification of make-proof earthing switch			M0, E2
Rated operating sequence			O – 3 min – CO – 3 min – CO
Number of short-circuit breaking operations		n	6 or 20

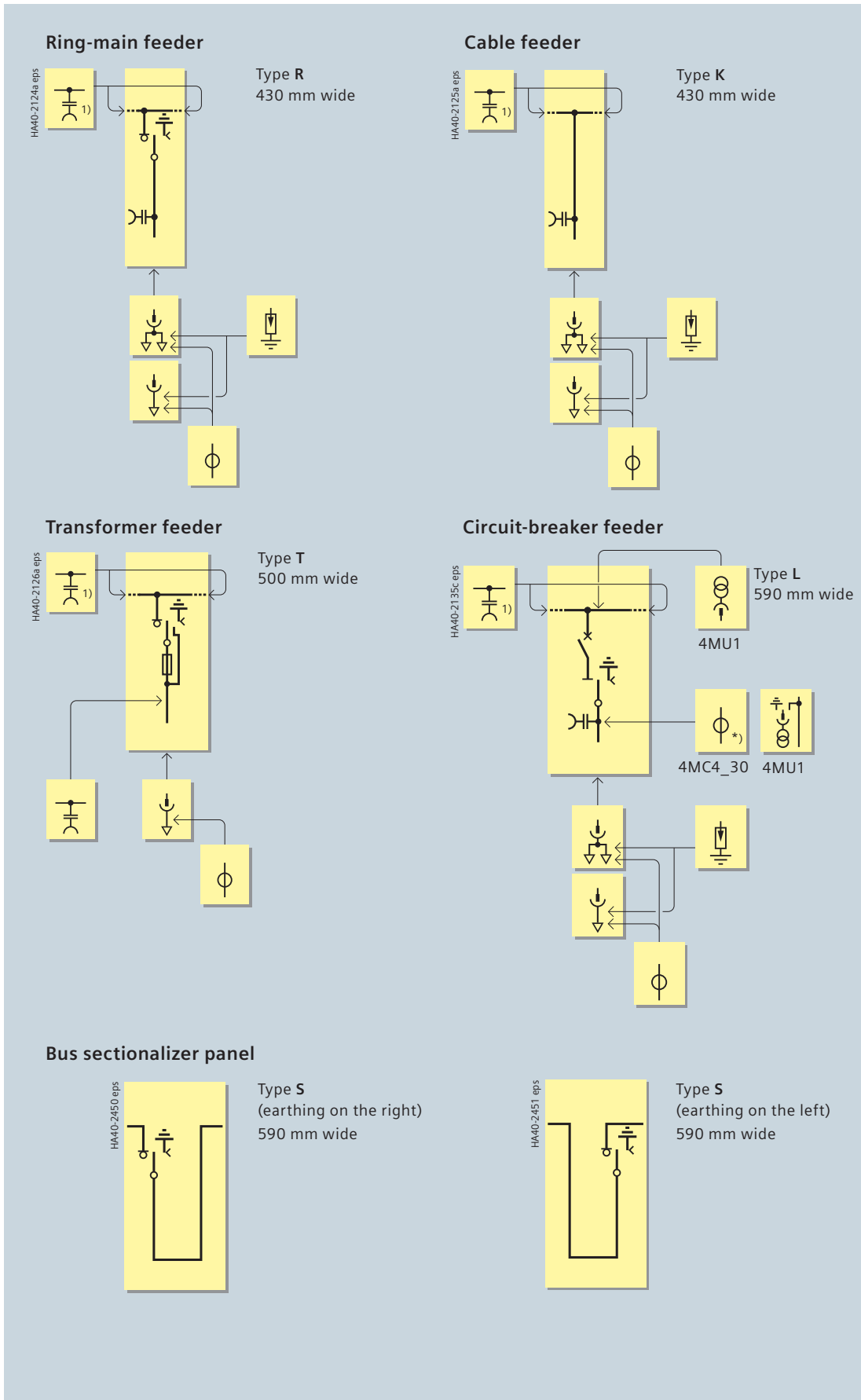



- 
Vacuum circuit-breaker

- 
Three-position switch-disconnector

- 
Three-position disconnecter

- 
Capacitive voltage detecting system

- 
HV HRC fuse

- 
Current transformer on the bushing

- 
Cable-type current transformer

- 
Cable connection with outside cone (not included in the scope of supply)

- 
Surge arrester

- 
Plug-in voltage transformer

- 
Disconnectable and plug-in voltage transformer

1) Only for end panel, on the free connection side of the busbar

Product Range

Air-insulated billing metering panel type M, 1100 mm wide

Billing metering panels with cable connection on the left

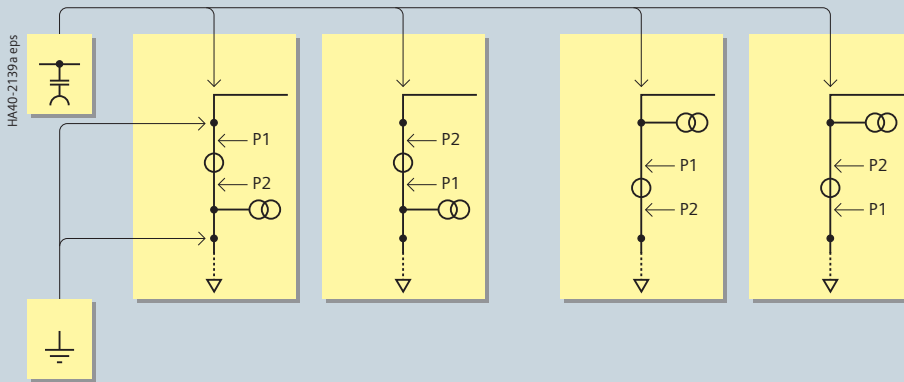

Billing metering panels with cable connection on the right

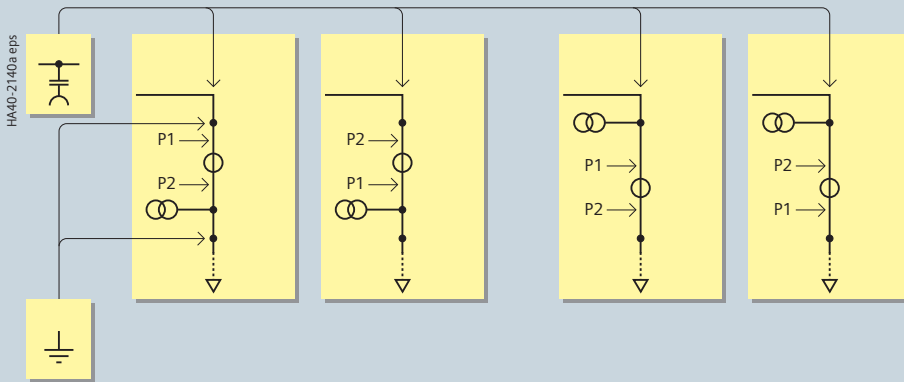

Billing metering panels with busbar connection on both sides

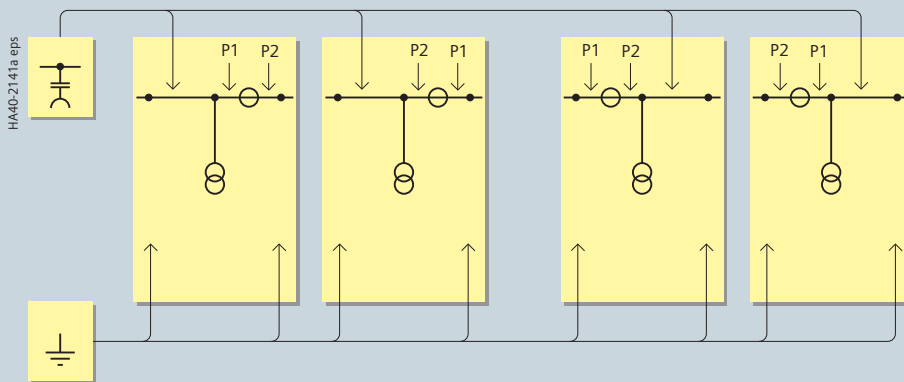

Billing metering panels with cable connection on both sides

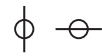
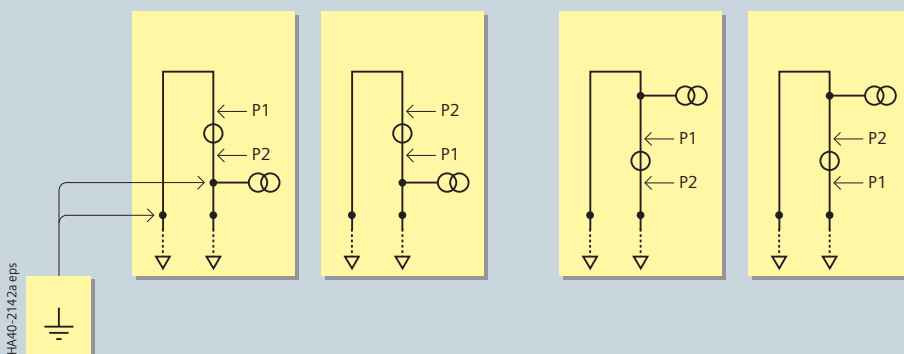

Current transformer, cast-resin insulated



Voltage transformer, cast-resin insulated



Capacitive voltage detecting system



Fixed earthing points for busbar earthing

P1 and P2 are terminal designations of the current transformer

Panel block Components shown in dotted lines can be used optionally.	Installation dimensions		
	Width	Depth	Height
	mm	mm	mm

Panel block Components shown in dotted lines can be used optionally.	Installation dimensions		
	Width	Depth	Height
	mm	mm	mm

Panel blocks with transformer feeders, optionally with busbar extension

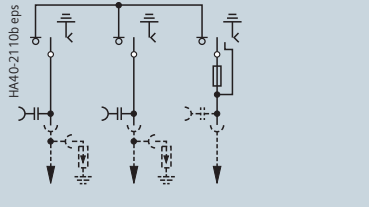
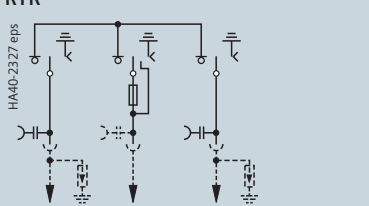
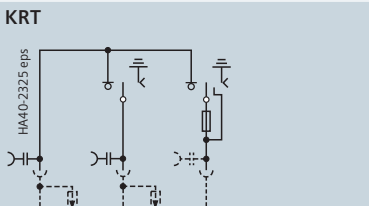
RRT 	2 ring-main feeders, 1 transformer feeder		
	1360	920	1600
RTR 	2 ring-main feeders, 1 transformer feeder		
	1360	920	1600
KRT 	1 cable feeder, 1 ring-main feeder, 1 transformer feeder		
	1360	920	1600

Panel blocks with circuit-breaker feeders, optionally with busbar extension

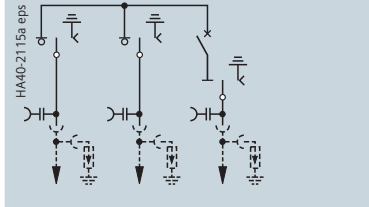
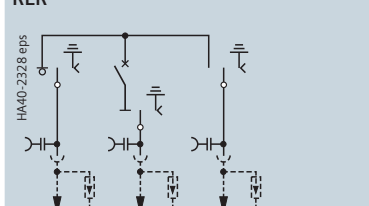
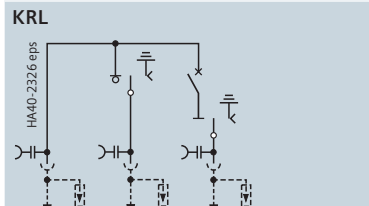
RRL 	2 ring-main feeders, 1 circuit-breaker feeder		
	1450	920	1600
RLR 	2 ring-main feeders, 1 circuit-breaker feeder		
	1450	920	1600
KRL 	1 cable feeder, 1 ring-main feeder, 1 circuit-breaker feeder		
	1450	920	1600

Design

Panel design (examples)

Ring-main feeder

Type R

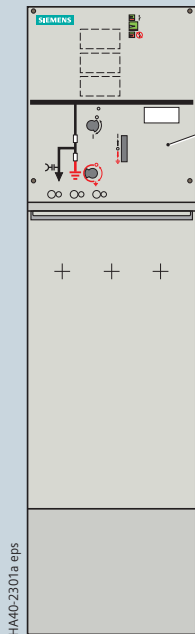

Section

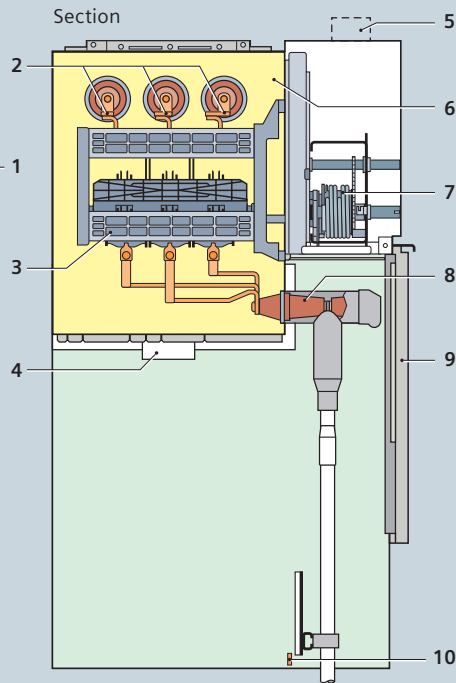

- 1 Control board (for details, see page 18)
- 2 Busbar arrangement
- 3 Three-position switch-disconnector
- 4 Pressure relief device
- 5 Wiring duct, removable, for protection and/or bus wires
- 6 Switchgear vessel, filled with gas
- 7 Operating mechanism of switching device
- 8 Bushing for cable plug with bolted contact (M16)
- 9 Cable compartment cover
- 10 Earthing busbar with earthing connection
- 11 HV HRC fuse assembly

Transformer feeder

Type T

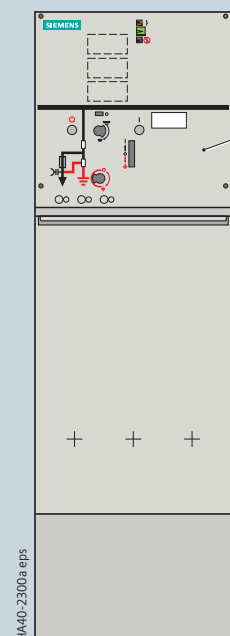

Section

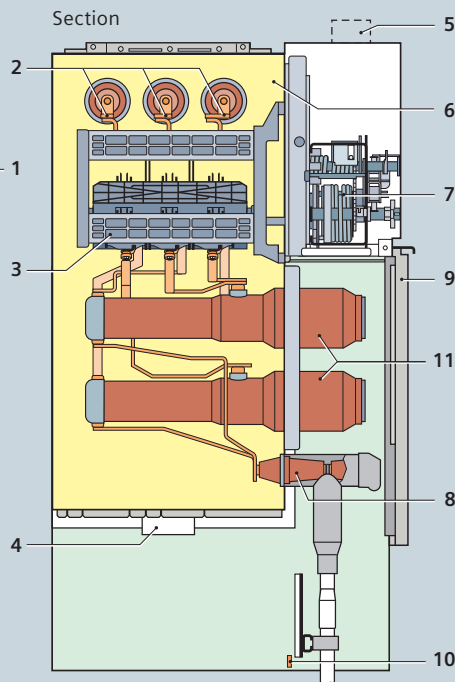

Circuit-breaker panel with indicated low-voltage compartment
Section

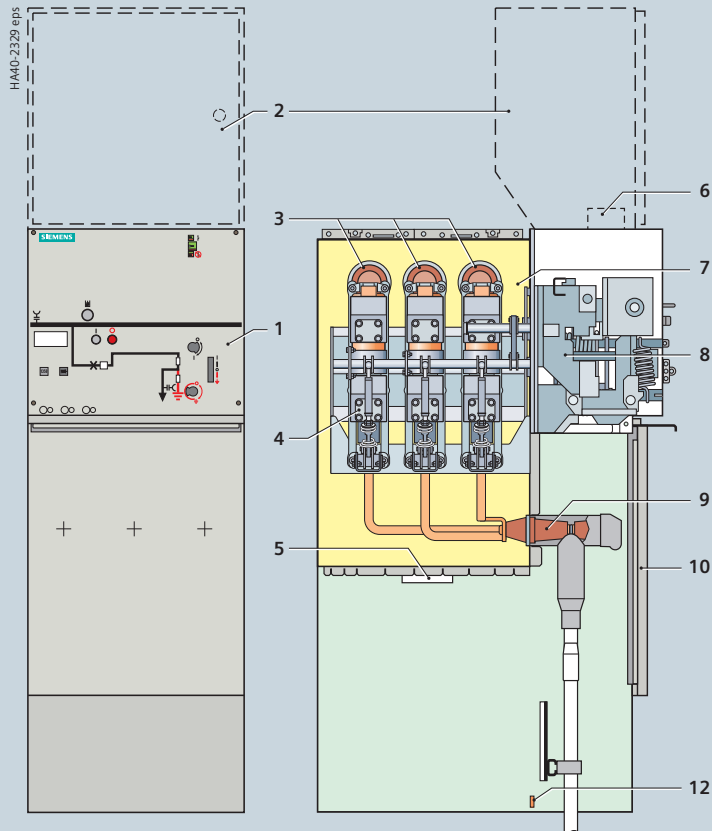

- 1 Control board (for details, see page 18)
- 2 Option: Low-voltage compartment
- 3 Busbar arrangement
- 4 Vacuum circuit-breaker and three-position switch module
- 5 Pressure relief device
- 6 Wiring duct, removable, for protection and/or bus wires
- 7 Switchgear vessel, filled with gas
- 8 Operating mechanism of switching devices
- 9 Bushing for cable plug with bolted contact (M16)
- 10 Cable compartment cover
- 11 Option: Current transformers on the bushing
- 12 Earthing busbar with earthing connection
- 13 Low-voltage compartment
- 14 Option: SIPROTEC bay controller
- 15 Option: Plug-in voltage transformer 4MU1 on the busbar
- 16 Option: Bushing for connection of plug-in voltage transformers on the busbar
- 17 Option: Disconnecting facility for the plug-in voltage transformer 4MU1 at the cable connection
- 18 Option: Bushing for connection of plug-in voltage transformers at the cable connection
- 19 Option: Plug-in voltage transformer 4MU1 at the cable connection

Circuit-breaker panel with 400 mm high low-voltage compartment
Section

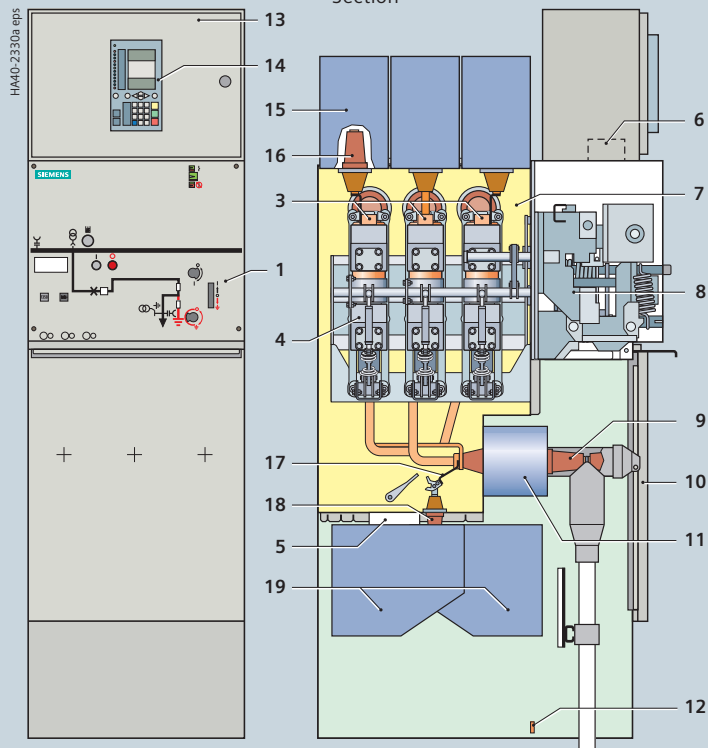

Design

Panel design (examples)

Billing metering panel

Type M, air-insulated

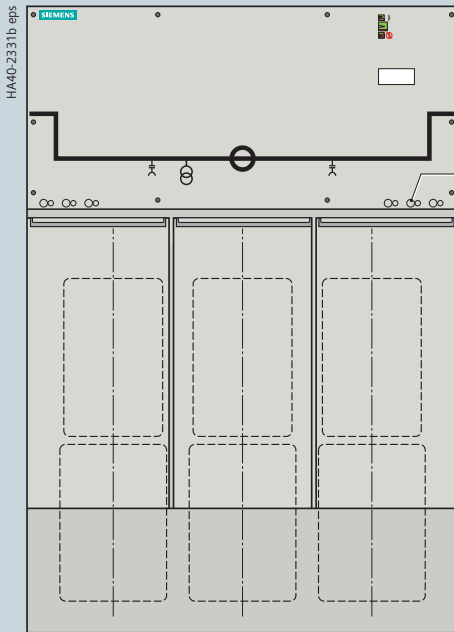

Connection: busbar – busbar

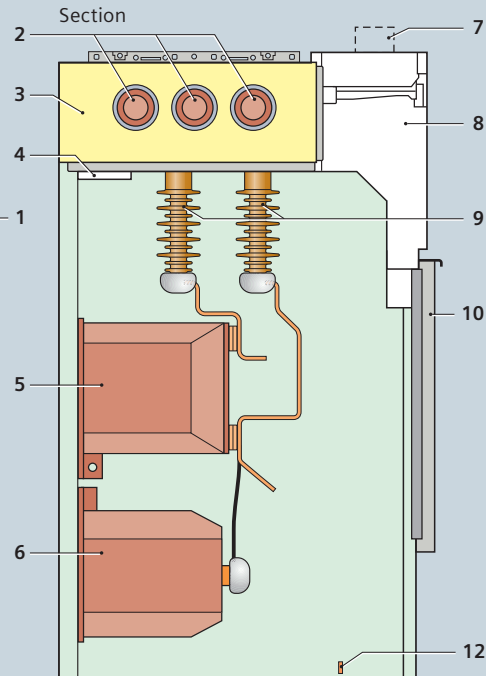

- 1 Sockets for voltage detecting system
- 2 Busbar connection
- 3 Busbar vessel, filled with gas
- 4 Pressure relief device
- 5 Current transformer type 4MA7
- 6 Voltage transformer type 4MR
- 7 Wiring duct, removable, for protection and/or bus wires
- 8 Niche for customer-side low-voltage equipment, screwed cover
- 9 Bushings for connection of transformer bars
- 10 Transformer compartment cover
- 11 Cable connection
- 12 Earthing busbar with earthing connection

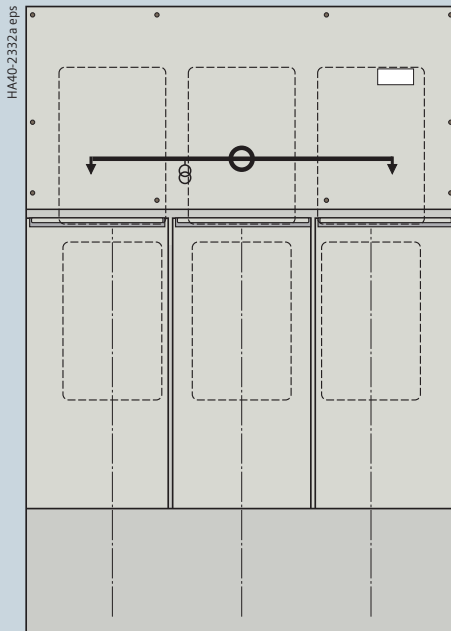

Connection: cable – cable

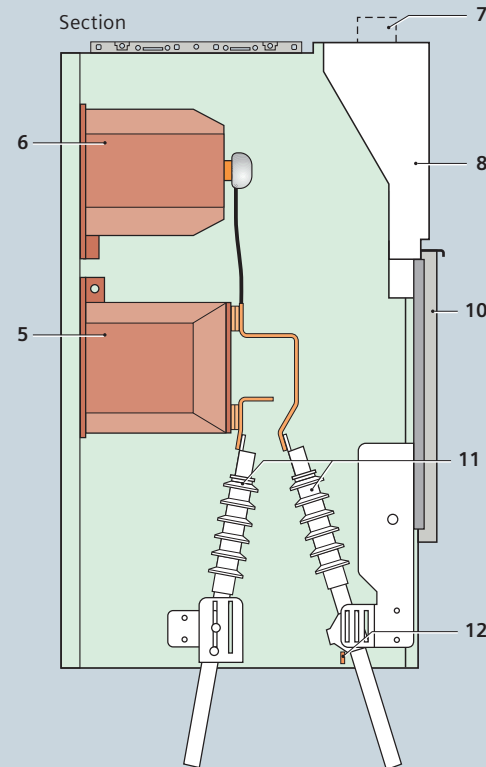

On request, 8DJH 36 switchgear can be provided with an outdoor enclosure with the following features:

- For outdoor applications on company grounds
- Enclosure attached to standard indoor panels
- Enclosure with three different heights (optionally with low-voltage compartment as a 200 mm, 400 mm or 600 mm high version)
- Enclosure with three different widths for freely configurable, non-extendable switchgear rows up to a switchgear width of 2040 mm (for dimensions, see page 59)
- Internal arc classification IAC A FL or FLR to 20 kA/1 s according to IEC 62271-200
- Degree of protection IP 54.



R-HA40-161.tif

Outdoor enclosure (front closed)

Design

Operation (examples)

The control boards are function-related. They integrate operation, mimic diagram and position indication. Furthermore, indicating, measuring and monitoring equipment as well as locking devices and local-remote switches are arranged according to the panel type and version. The ready-for-service indicator and rating plates are fitted in accordance with the panel blocks.

Operation is identical for transformer and circuit-breaker feeders. First, the operating mechanism must be charged; then, closing/opening is done through separate push-buttons. The condition of the energy store is indicated.

All actuating openings are functionally interlocked against each other, and are optionally lockable. Separate operating levers for the disconnecting and earthing function are optionally available.

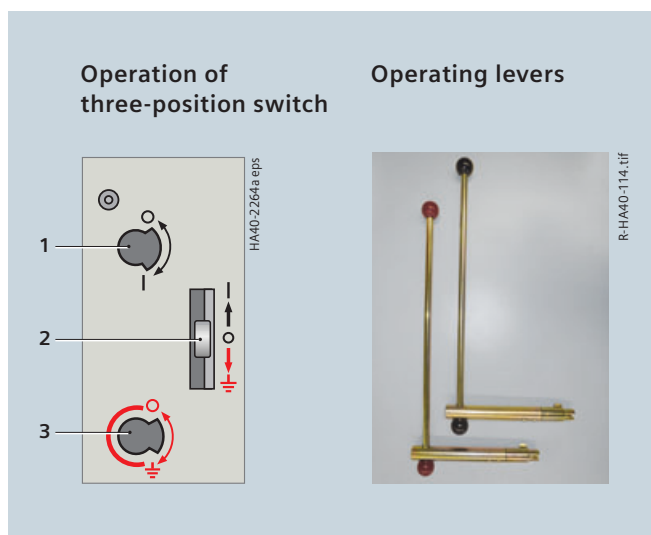

- 1 Manual operation of load-break function
- 2 Locking function (option for ring-main feeders)
- 3 Manual operation of earthing function
- 4 Panel designation label
- 5 Position indicator for switch-disconnector
- 6 Position indicator for earthing switch
- 7 Sockets of capacitive voltage detecting system
- 8 "Fuse tripped" indicator
- 9 ON pushbutton for transformer feeder and circuit-breaker feeder
- 10 OFF pushbutton for transformer feeder and circuit-breaker feeder
- 11 Manual spring charging
- 12 "Spring charged" indicator
- 13 Position indicator for circuit-breaker
- 14 Operations counter

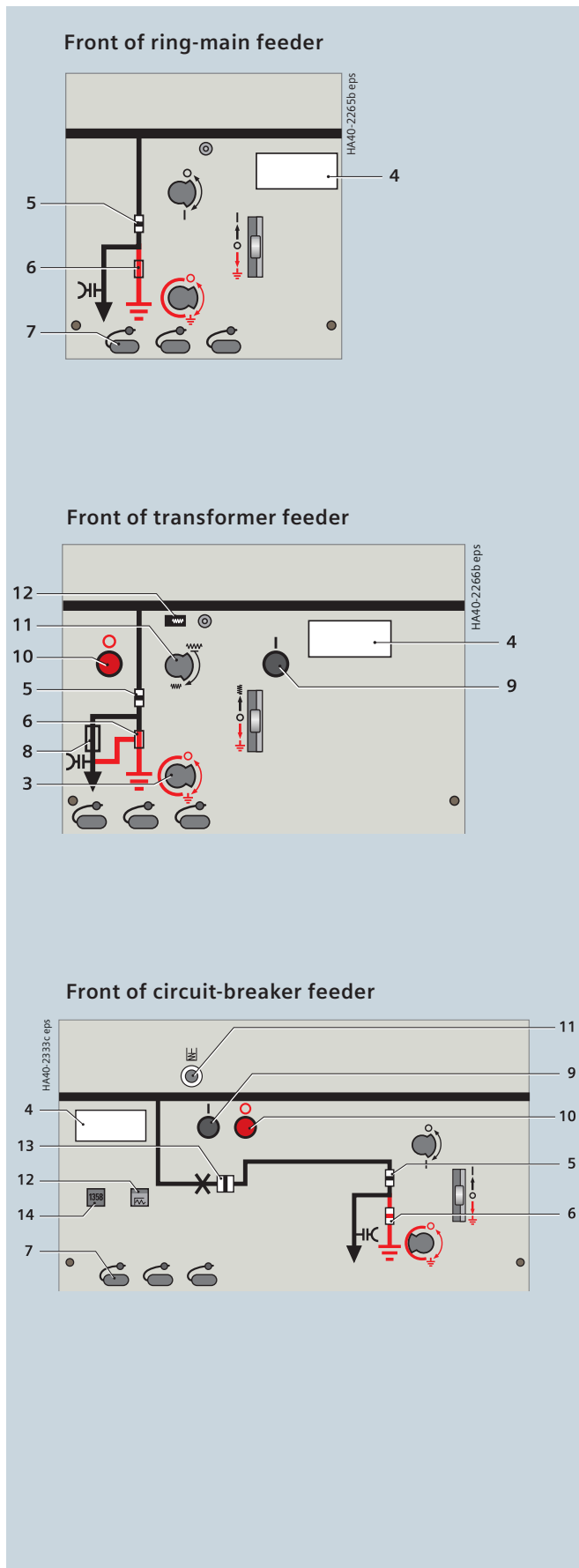

Features

- Switch positions: CLOSED – OPEN – EARTHED
- Switching functions as general-purpose switch-disconnector (class E3) according to
 - IEC/EN 62271-103/VDE 0671-103
 - IEC/EN 62271-102/VDE 0671-102
- Designed as a three-position switch with the functions
 - Switch-disconnector and
 - Make-proof earthing switch
- Operation via rotary bushing welded gas-tight into the front of the switchgear vessel
- Climate-independent contact in the gas-filled switchgear vessel
- Maintenance-free for indoor installation according to IEC/EN 62271-1/VDE 0671-1
- Individual secondary equipment.

Mode of operation

The operating shaft forms one unit together with the three contact blades. Due to the arrangement of the fixed contacts (earth – busbar), it is not necessary to interlock the CLOSE and EARTHING functions.

Closing operation

During the closing operation, the operating shaft with the moving contact blades changes from the “OPEN” to the “CLOSED” position.

The force of the spring-operated mechanism ensures a high operator-independent closing speed and a reliable connection of the main circuit.

Opening operation

During the opening operation, the arc is caused to rotate by the arc-suppression system. This rotation movement prevents the development of a fixed root.

The isolating distance in gas established after breaking fulfills the conditions applicable to isolating distances in accordance with

– IEC/EN 62271-102/VDE 0671-102

and

– IEC/EN 62271-1/VDE 0671-1.

Due to the arc rotation caused by the arc-suppression system, both load currents and minor no-load currents are safely interrupted.

Earthing operation

The EARTHING operation is implemented by changing from the “OPEN” to the “EARTHED” position.

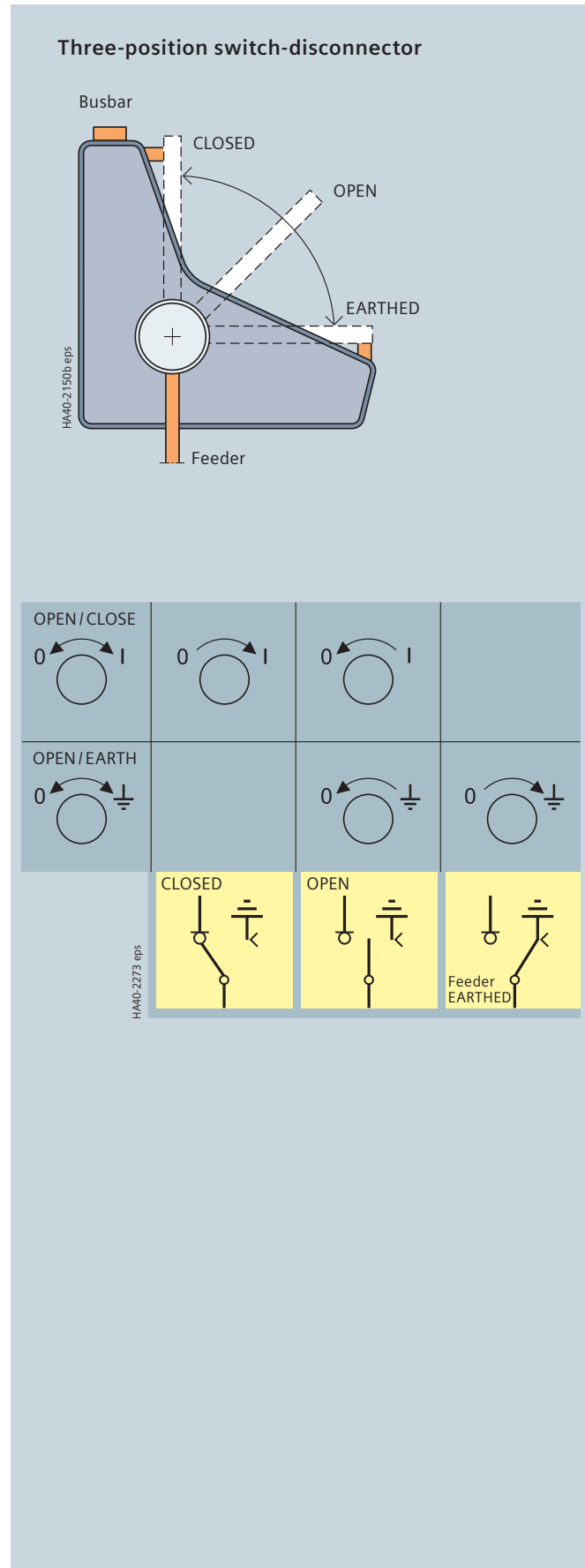

Components

Operating mechanisms for the three-position switch, equipment (optional)

Features

- Mechanical endurance of more than 1000 operating cycles
- Parts subjected to mechanical stress are highly corrosion-proof
- Manual operation with the help of a slip-on operating lever
- Option: Motor operation
- Control board with accordingly cut-out switching gate prevents the three-position switch-disconnector from being switched directly from the "CLOSED" via the "OPEN" to the "EARTHED" position
- Two separate actuating openings are provided for unambiguous selection of the DISCONNECTING and EARTHING functions
- Operation via rotary movement, operating direction according to IEC/EN 60447/VDE 0196 (FNN recommendation, formerly VDN/VDEW recommendation).

Spring-operated mechanism

The switching movements are performed independently of the operating speed.

Spring-operated/stored-energy mechanism

The switching movements are performed independently of the operating speed.

During the charging process, the closing and opening springs are charged. This ensures that the switch-disconnector/fuse combination can switch off all types of faults reliably even during closing.

Closing and opening is done via pushbuttons, and is therefore identical with the operation of circuit-breaker operating mechanisms.

An energy store is available for tripping by means of an operating HV HRC fuse or via a shunt release (f-release).

After tripping, a red bar appears on the switch position indication.

Assignment of operating mechanism type of three-position switch to panel types

Panel type	R, S, L	
Function	Switch-disconnector (R,S) Disconnector (L)	Earthing switch
Type of operating mechanism	Spring-operated	Spring-operated
Operation	Manual Motor (option)	Manual
Panel type	T	
Function	Switch-disconnector (T)	Earthing switch
Earthing switch	Stored-energy	Spring-operated
Operation	Manual Motor (option)	Manual

Legend:

- R = Ring-main feeder
- S = Bus sectionalizer panel
- L = Circuit-breaker feeder
- T = Transformer feeder

Motor operating mechanism (option)

The manual operating mechanisms of 8DJH 36 switchgear can be equipped with motor operating mechanisms for the three-position switch-disconnector. Retrofitting is possible.

Operating voltages for motor operating mechanisms:

- 24, 48, 60, 110, 220 V DC
- 110 and 230 V AC, 50/60 Hz
- Motor rating: maximum 80 W/80 VA

Operation:

- Local operation by momentary-contact rotary control switch (option)
- Remote operation (standard) applied to terminal.

Shunt release (option) (f-release)

Stored-energy mechanisms can be equipped with a shunt release. Remote electrical tripping of the three-position switch-disconnector is possible via the magnet coil of the shunt release, e.g. transformer overtemperature tripping.

To avoid thermal overloading of the shunt release in the event of a continuous signal that may be applied, the shunt release is switched off via an auxiliary switch which is mechanically coupled with the three-position switch-disconnector.

Auxiliary switch (option)

Each operating mechanism of the three-position switch-disconnector can be optionally equipped with an auxiliary switch for the position indication. Free contacts (for manual operating mechanism):

- Switch-disconnector function:
CLOSED and OPEN: 1 NO + 1 NC + 2 changeover
- Earthing switch function:
CLOSED and OPEN: 1 NO + 1 NC + 2 changeover.

Technical data of the auxiliary switch

Breaking capacity

AC operation at 40 Hz up to 60 Hz		DC operation		
Operating voltage	Normal current	Operating voltage	Normal current	
V	A	V	Resistive A	Inductive, T = 20 ms A
up to 230	10	24	10	10
		48	10	9
		60	9	7
		110	5	4
		240	2.5	2

Rated switching capacity

Rated insulation voltage	250 V AC/DC
Insulation group	C acc. to VDE 0110
Continuous current	10 A
Making capacity	50 A

Abbreviations:

- NO = Normally open contact
- NC = Normally closed contact

Features

- The vacuum circuit-breaker consists of a vacuum interrupter unit with integrated three-position disconnecter located in the switchgear vessel, and the associated operating mechanisms.
- According to IEC/EN 62271-100/VDE 0671-100
- Application in hermetically welded switchgear vessel in conformity with the system
- Climate-independent vacuum interrupter poles in the gas-filled switchgear vessel
- Operating mechanism located outside the switchgear vessel in the front operating mechanism box
- Maintenance-free for indoor installation according to IEC/EN 62271-1/VDE 0671-1
- Individual secondary equipment.

Operating mechanism functions

The closing spring is charged by means of the operating lever or the hand crank supplied, or by the motor (option in L2 panel), until the latching of the closing spring is indicated ("spring charged" indicator). Then, the vacuum circuit-breaker can be closed manually or electrically.

In operating mechanisms provided for automatic reclosing (AR), the closing spring can be recharged by hand or automatically in case of motor operating mechanism. Thus, the "closing option" is available again.

Operating mechanism

The operating mechanism assigned to a circuit-breaker feeder consists of the following components:

- Operating mechanism for circuit-breaker
- Operating mechanism for three-position disconnecter
- Motor operating mechanism (option in L2 panel)
- Position indicators
- Pushbuttons for CLOSING and OPENING the circuit-breaker
- Interlocking between circuit-breaker and three-position disconnecter.

Assignment of operating mechanism type

Panel type	L		
Function	Circuit-breaker	Three-position disconnecter	
		Disconnecter	Earthing switch
Type	Stored-energy	Spring-operated	Spring-operated
Operation	Manual/Motor	Manual/Motor	Manual

Trip-free mechanism

The vacuum circuit-breaker is fitted with a trip-free mechanism according to IEC/EN 62271-100/VDE 0671-100. In the event of an opening command being given after a closing operation has been initiated, the moving contacts return to the open position and remain there even if the closing command is sustained. This means that the contacts are momentarily in the closed position, which is permissible according to the above-mentioned standard.

Circuit-breaker

Circuit-breaker	Type 1	Type 2
Short-circuit breaking current I_{SC}	up to 20 kA	up to 20 kA
Rated operating sequence O – 0.3 s – CO – 3 min – CO O – 0.3 s – CO – 15 s – CO O – 3 min – CO – 3 min – CO	• on request –	– – •
Number of breaking operations I_t	10,000	2000
short-circuit breaking operations	up to 50	up to 20
In individual panel	590 mm •	•
In panel block	590 mm •	•

Explanations:

- Design option
- Not available

Components

Vacuum circuit-breaker

Electrical service life

Vacuum circuit-breaker type 1

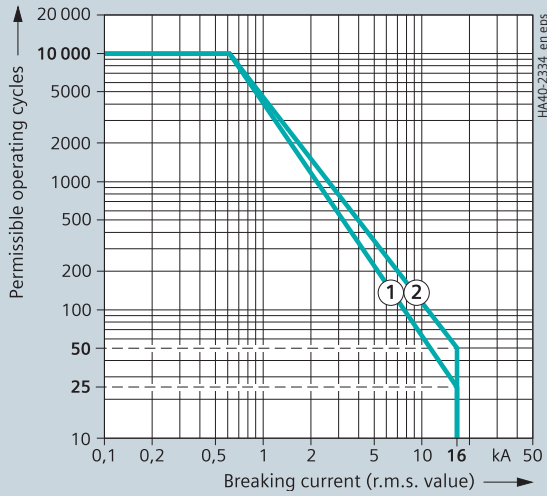

Rated short-circuit breaking current 16 kA

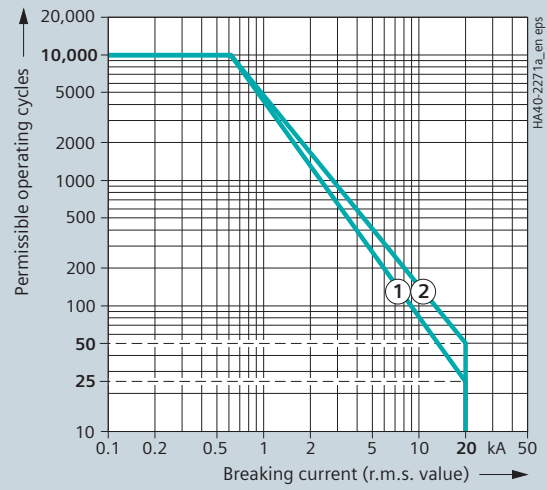

Rated short-circuit breaking current 20 kA

Vacuum circuit-breaker type 2

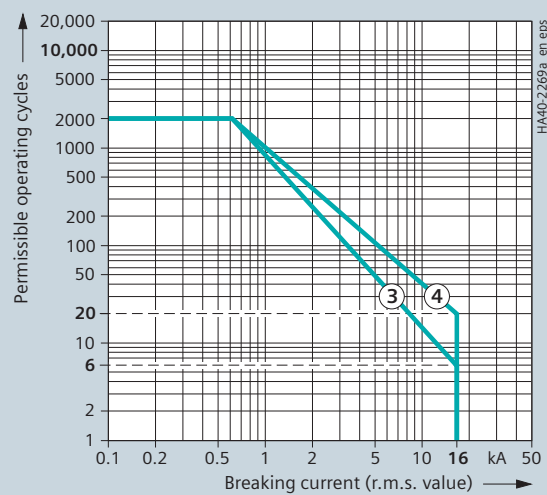

Rated short-circuit breaking current 16 kA

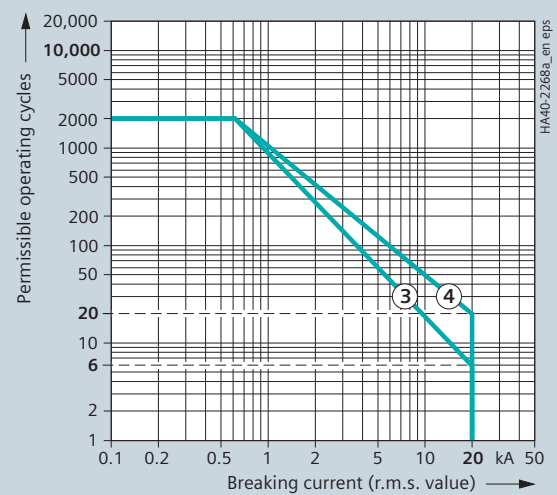

Rated short-circuit breaking current 20 kA

Max. number of short-circuit breaking operations

- ① n = 25 ③ n = 6
- ② n = 50 ④ n = 20

Motor operating mechanism (option for type 2)

Operating voltages for motor operating mechanisms:

- 24, 48, 60, 110, 220 V DC
- 110 and 230 V AC, 50/60 Hz.

Further values on request.

Motor rating for circuit-breaker operating mechanism at
DC: maximum 500 W
AC: maximum 650 VA.

Secondary components

The scope of the secondary equipment of the vacuum circuit-breaker depends on the type of application and offers a wide range of possible variations, allowing almost every requirement to be satisfied.

Closing solenoid (option for type 2)

- For electrical closing.

Shunt release

- Magnet coil for tripping by protection device or electrical actuation.

C.t.-operated release

- For tripping pulse 0.1 Ws in conjunction with suitable protection systems, e.g. protection system 7SJ45 or make Woodward / SEG type WIC; other designs on request
- Used if external auxiliary voltage is missing, tripping via protection relay.

Undervoltage release

- Comprising:
 - Energy store and unlatching mechanism
 - Electromagnetic system, which is permanently connected to voltage while the vacuum circuit-breaker is closed; tripping is initiated when this voltage drops.

Anti-pumping

(mechanical and electrical)

- Function: If constant CLOSE and OPEN commands are present at the vacuum circuit-breaker at the same time, the vacuum circuit-breaker will return to the open position after closing. It remains in this position until a new CLOSE command is given. In this manner, continuous closing and opening (= pumping) is avoided.

Circuit-breaker tripping signal

- For electrical signaling (as pulse > 10 ms), e.g. to remote control systems, in the case of automatic tripping (e.g. protection)
- Via limit switch and cutout switch.

Varistor module

- To limit overvoltages to approx. 500 V for protection devices (when inductive components are mounted in the vacuum circuit-breaker)
- For auxiliary voltages ≥ 60 V DC.

Auxiliary switch

- Standard: 6 NO + 6 NC, free contacts thereof ¹⁾ 1 NO + 2 NC + 2 changeover
- Option: 11 NO + 11 NC, free contacts thereof ¹⁾ 6 NO + 7 NC + 2 changeover.

Position switch

- For signaling "closing spring charged".

Mechanical interlocking

- Dependent on the type of operating mechanism
- Interrogation of the three-position disconnecter from the switchgear side
- Option: Operating mechanism with mechanical interlocking as
 - Stored-energy mechanism with closing solenoid and pushbutton: The pushbutton operated by the mechanical interlocking prevents a continuous command to the closing solenoid
- During operation of the three-position disconnecter from CLOSED to OPEN, the vacuum circuit-breaker cannot be closed.

Operations counter

1) Depending on the secondary components selected

Components

Busbar extension, modularity

Features

- Busbar extension possible on all individual panels and panel blocks (ordering option)
- Plug-in unit consisting of contact coupling and screened silicone coupling
- Insensitive to pollution and condensation
- Switchgear installation, extension or panel replacement is possible without gas work.

Every switchgear block and every individual panel is optionally available with busbar extension on the right, on the left or on both sides. This offers a high flexibility for the creation of switchgear configurations the functional units of which are lined up in any order. Local installation and lining up is done without gas work.

Lining up takes place as follows:

- By the busbar couplings on the medium-voltage side. Tolerances between adjacent panels are compensated by spherical fixed contacts and the movable contact coupling with degrees of freedom in all axis directions.
- By safe dielectric sealing with screened silicone couplings that are externally earthed and adjustable to tolerances. These silicone couplings are pressed on with a defined pressure when the panels are interconnected.
- On free busbar ends, screened dummy plugs are inserted, each of which is pressed on through a metal cover. A common protective cover with a warning is fixed over all three covers.
- By centering bolts for easier switchgear installation and fixing of adjacent panels.
- By bolted panel joints with defined stops for the distances between adjacent panels and the associated pressure of contact pieces and silicone couplings.

Switchgear installation, extension or replacement of one or more functional units requires a lateral wall distance ≥ 200 mm.

Interconnecting the panels

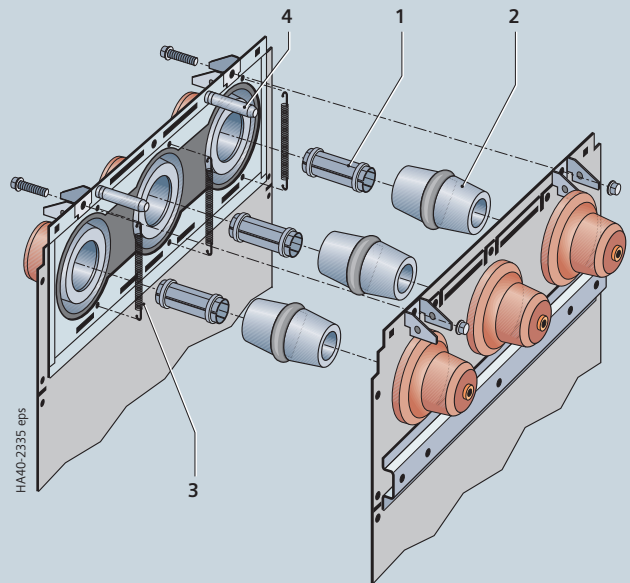

Surge-proof termination

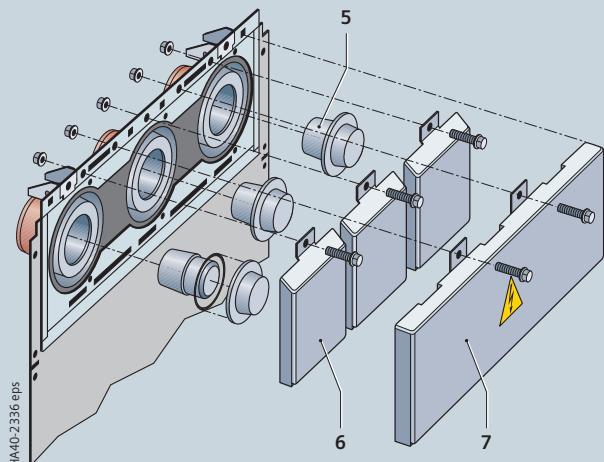

- 1 Contact piece
- 2 Silicone coupling
- 3 Tension spring for earthing
- 4 Centering bolt
- 5 Silicone dummy plug with insertable sleeve
- 6 Clamping cover for dummy plugs
- 7 Busbar termination cover

Features

- Application for switch-disconnector/fuse combination in
 - Transformer feeders (T)
- HV HRC fuse-links according to DIN 43625 (main dimensions) with striker; “medium” version according to IEC/EN 60282-1/VDE 0670-4
- As short-circuit protection for transformers
- With selectivity – depending on correct selection – to upstream and downstream connected equipment
- 1-pole insulated
- Requirements according to IEC/EN 62271-105/ VDE 0671-105 fulfilled in high-voltage switch-fuse combinations
- Climate-independent and maintenance-free
- Arrangement of fuse assembly in the switchgear vessel
- Fuse can only be replaced if feeder is earthed
- Fuse assembly for applications with a reference dimension of 537 mm.

Option with three-position switch-disconnector

- Shunt release (f-release)
- “Tripped signal” of the transformer switch for remote electrical indication with 1 normally open contact.

Mode of operation

In the event that an HV HRC fuse-link has tripped, the switch-disconnector is tripped via an articulation which is integrated into the cover of the fuse box (see figure).

In the event that the fuse tripping fails, e.g. if the fuse has been inserted incorrectly, the fuse box is protected by thermal protection. The overpressure generated by overheating trips the switch via the diaphragm in the cover of the fuse box and via an articulation. This prevents the fuse box from incurring irreparable damage.

This thermal protection works independently of the type and design of the HV HRC fuse used. Like the fuse itself, it is maintenance-free and independent of any outside climatic effects.

Furthermore, the HV HRC fuses (e.g. make SIBA) release the striker depending on the temperature and trip the switch-disconnector as early as in the fuse overload range.

Impermissible heating of the fuse box can be avoided in this way.

Replacement of HV HRC fuse-links

- Isolate and earth the transformer feeder
- Open the cover of the fuse access
- Replace the HV HRC fuse-link.

Note to HV HRC fuse-links

According to IEC 60282-1 (2009) Clause 6.6, the breaking capacity of HV HRC fuses is tested within the scope of the type test at 87% of their rated voltage. In three-phase systems with resonance-earthed or isolated neutral, under double earth fault and other conditions, the full phase-to-phase voltage may be available at the HV HRC fuse during breaking. Depending on the size of the operating voltage of such a system, this applied voltage may then exceed

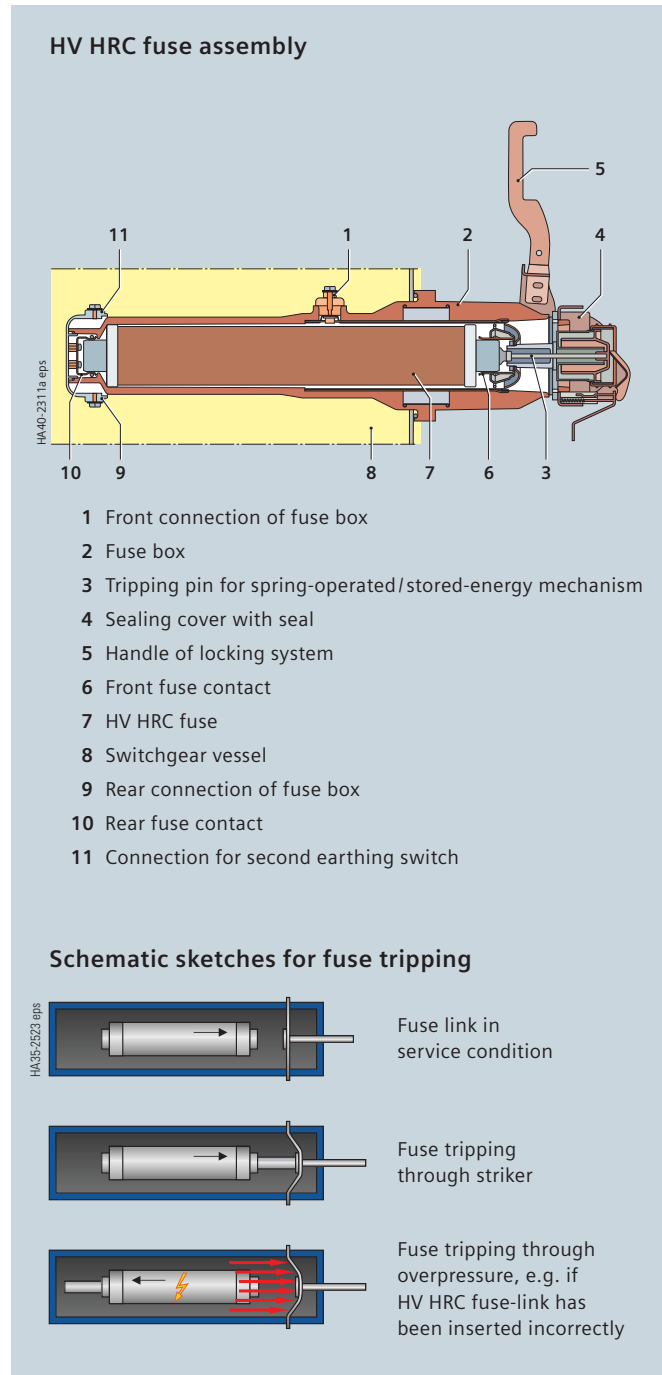

87% of the rated voltage. It must therefore already be ensured during configuration of the switching devices and selection of the HV HRC fuse that only such fuse-links are used, which either satisfy the above operating conditions, or whose breaking capacity was tested at least with the maximum system voltage. In case of doubt, a suitable HV HRC fuse must be selected together with the fuse manufacturer.

Components

Allocation of HV HRC fuses and transformer ratings

Allocation of HV HRC fuses and transformers

The following table shows the recommended HV HRC fuse-links make SIBA (electrical data valid for ambient air temperatures of up to 40 °C) for fuse protection of transformers.

Fuse protection table

The three-position switch-disconnector in the transformer feeder (transformer switch) was combined and tested according to IEC 62271-105 with HV HRC fuse-links type HHD-B resp. HHD-BSSK.

Standards

HV HRC fuse-links "medium" version with striker and tripping energy 1 ± 0.5 Joule according to

- IEC/EN 60282-1/VDE 0670-4
- IEC/TR 62655/VDE 0670-402
- DIN 43625 main dimensions.

MV system Operating voltage U_n kV	Transformer			HV HRC fuse-link				
	Rated power S_r kVA	Relative impedance voltage u_k %	Rated current I_r A	Rated current I_r A	Min. operating/ rated voltage U_r kV	Dimension "e" mm	Outside diameter d mm	Order No. Make SIBA
24	75	4	1.8	6.3	20 to 36	537	53	30 008 13.6.3
	100	4	2.4	6.3	20 to 36	537	53	30 008 13.6.3
	125	4	3.0	10	20 to 36	537	53	30 008 13.10
	160	4	3.9	10	20 to 36	537	53	30 008 13.10
	200	4	4.8	16	20 to 36	537	53	30 008 13.16
	250	4	6.0	16	20 to 36	537	53	30 008 13.16
	315	4	7.6	20	20 to 36	537	53	30 008 13.20
	400	4	9.6	20	20 to 36	537	53	30 008 13.20
	500	4	12.0	25	20 to 36	537	53	30 008 13.25
	630	4	15.2	31.5	20 to 36	537	67	30 016 13.31.5
	800	5	19.3	31.5	20 to 36	537	67	30 016 13.31.5
	800	6	19.3	31.5	20 to 36	537	67	30 016 13.31.5
	1000	5	24.1	40	20 to 36	537	67	30 016 13.40
	1000	6	24.1	40	20 to 36	537	67	30 016 13.40
	1250	5	30.1	50	20 to 36	537	85	30 024 13.50
	1250	6	30.1	50	20 to 36	537	85	30 024 13.50
	1600	5	38.5	63	20 to 36	537	85	30 024 43.63 ¹⁾
	1600	6	38.5	63	20 to 36	537	85	30 024 43.63 ¹⁾
	2000	5	48.1	80	20 to 36	537	85	30 024 43.80 ¹⁾
	2000	6	48.1	80	20 to 36	537	85	30 024 43.80 ¹⁾
25	75	4	1.7	6.3	20 to 36	537	53	30 008 13.6.3
	100	4	2.3	6.3	20 to 36	537	53	30 008 13.6.3
	125	4	2.9	10	20 to 36	537	53	30 008 13.10
	160	4	3.7	10	20 to 36	537	53	30 008 13.10
	200	4	4.6	16	20 to 36	537	53	30 008 13.16
	250	4	5.8	16	20 to 36	537	53	30 008 13.16
	315	4	7.3	20	20 to 36	537	53	30 008 13.20
	400	4	9.2	20	20 to 36	537	53	30 008 13.20
	500	4	11.6	25	20 to 36	537	53	30 008 13.25
	630	4	14.6	31.5	20 to 36	537	67	30 016 13.31.5
	800	5	18.5	31.5	20 to 36	537	67	30 016 13.31.5
	800	6	18.5	31.5	20 to 36	537	67	30 016 13.31.5
	1000	5	24.1	40	20 to 36	537	67	30 016 13.40
	1000	6	24.1	40	20 to 36	537	67	30 016 13.40
	1250	5	30.1	50	20 to 36	537	85	30 024 13.50
	1250	6	30.1	50	20 to 36	537	85	30 024 13.50
	1600	5	38.5	63	20 to 36	537	85	30 024 43.63 ¹⁾
	1600	6	38.5	63	20 to 36	537	85	30 024 43.63 ¹⁾
	2000	5	48.1	80	20 to 36	537	85	30 024 43.80 ¹⁾
	2000	6	48.1	80	20 to 36	537	85	30 024 43.80 ¹⁾
25.8	75	4	1.7	6.3	20 to 36	537	53	30 008 13.6.3
	100	4	2.2	6.3	20 to 36	537	53	30 008 13.6.3
	125	4	2.8	10	20 to 36	537	53	30 008 13.10
	160	4	3.6	10	20 to 36	537	53	30 008 13.10
	200	4	4.5	16	20 to 36	537	53	30 008 13.16
	250	4	5.6	16	20 to 36	537	53	30 008 13.16
	315	4	7.1	20	20 to 36	537	53	30 008 13.20
	400	4	9.0	20	20 to 36	537	53	30 008 13.20
	500	4	11.2	25	20 to 36	537	53	30 008 13.25
	630	4	14.1	31.5	20 to 36	537	67	30 016 13.31.5
	800	5	17.9	31.5	20 to 36	537	67	30 016 13.31.5
	800	6	17.9	31.5	20 to 36	537	67	30 016 13.31.5
	1000	5	22.4	40	20 to 36	537	67	30 016 13.40
	1000	6	22.4	40	20 to 36	537	67	30 016 13.40
	1250	5	28.0	50	20 to 36	537	85	30 024 13.50
	1250	6	28.0	50	20 to 36	537	85	30 024 13.50
	1600	5	35.8	63	20 to 36	537	85	30 024 43.63 ¹⁾
	1600	6	35.8	63	20 to 36	537	85	30 024 43.63 ¹⁾
	2000	5	44.8	80	20 to 36	537	85	30 024 43.80 ¹⁾
	2000	6	44.8	80	20 to 36	537	85	30 024 43.80 ¹⁾

1) For 1600 kVA and 2000 kVA, HHD-BSSK fuse-links are used.

Continued on next page

MV system	Transformer			HV HRC fuse-link				
	Rated power S_r	Relative impedance voltage u_k	Rated current I_r	Rated current I_r	Min. operating/ rated voltage U_r	Dimension "e" mm	Outside diameter d	Order No. Make SIBA
kV	kVA	%	A	A	kV	mm	mm	
27.6	75	4	1.6	6.3	20 to 36	537	53	30 008 13.6.3
	100	4	2.1	6.3	20 to 36	537	53	30 008 13.6.3
	125	4	2.6	10	20 to 36	537	53	30 008 13.10
	160	4	3.4	10	20 to 36	537	53	30 008 13.10
	200	4	4.2	10	20 to 36	537	53	30 008 13.10
	250	4	5.2	16	20 to 36	537	53	30 008 13.16
	315	4	6.6	16	20 to 36	537	53	30 008 13.16
	400	4	8.4	20	20 to 36	537	53	30 008 13.20
	500	4	10.5	25	20 to 36	537	53	30 008 13.25
	630	4	13.2	31.5	20 to 36	537	67	30 016 13.31.5
	800	5	16.8	31.5	20 to 36	537	67	30 016 13.31.5
	800	6	16.8	31.5	20 to 36	537	67	30 016 13.31.5
	1000	5	21.0	40	20 to 36	537	67	30 016 13.40
	1000	6	21.0	40	20 to 36	537	67	30 016 13.40
	1250	5	26.2	50	20 to 36	537	85	30 024 13.50
	1250	6	26.2	50	20 to 36	537	85	30 024 13.50
	1600	5	33.5	63	20 to 36	537	85	30 024 43.63 ¹⁾
	1600	6	33.5	63	20 to 36	537	85	30 024 43.63 ¹⁾
	2000	5	41.9	80	20 to 36	537	85	30 024 43.80 ¹⁾
	2000	6	41.9	80	20 to 36	537	85	30 024 43.80 ¹⁾
2500	5	52.4	80	20 to 36	537	85	30 024 43.80 ¹⁾	
2500	6	52.4	80	20 to 36	537	85	30 024 43.80 ¹⁾	
30	75	4	1.5	6.3	20 to 36	537	53	30 008 13.6.3
	100	4	1.9	6.3	20 to 36	537	53	30 008 13.6.3
	125	4	2.4	6.3	20 to 36	537	53	30 008 13.6.3
	160	4	3.1	10	20 to 36	537	53	30 008 13.10
	200	4	3.9	10	20 to 36	537	53	30 008 13.10
	250	4	4.8	16	20 to 36	537	53	30 008 13.16
	315	4	6.1	16	20 to 36	537	53	30 008 13.16
	400	4	7.7	20	20 to 36	537	53	30 008 13.20
	500	4	9.6	20	20 to 36	537	53	30 008 13.20
	630	4	12.1	25	20 to 36	537	53	30 008 13.25
	800	5	15.4	31.5	20 to 36	537	67	30 016 13.31.5
	800	6	15.4	31.5	20 to 36	537	67	30 016 13.31.5
	1000	5	19.3	31.5	20 to 36	537	67	30 016 13.31.5
	1000	6	19.3	31.5	20 to 36	537	67	30 016 13.31.5
	1250	5	24.1	40	20 to 36	537	67	30 016 13.40
	1250	6	24.1	40	20 to 36	537	67	30 016 13.40
	1600	5	30.8	63	20 to 36	537	85	30 024 43.63 ¹⁾
	1600	6	30.8	63	20 to 36	537	85	30 024 43.63 ¹⁾
	2000	5	38.5	80	20 to 36	537	85	30 024 43.80 ¹⁾
	2000	6	38.5	80	20 to 36	537	85	30 024 43.80 ¹⁾
2500	5	48.2	80	20 to 36	537	85	30 024 43.80 ¹⁾	
2500	6	48.2	80	20 to 36	537	85	30 024 43.80 ¹⁾	
36	100	4	1.6	6.3	20 to 36	537	53	30 008 13.6.3
	125	4	2	6.3	20 to 36	537	53	30 008 13.6.3
	160	4	2.6	10	20 to 36	537	53	30 008 13.10
	200	4	3.2	10	20 to 36	537	53	30 008 13.10
	250	4	4	10	20 to 36	537	53	30 008 13.10
	315	4	5.1	16	20 to 36	537	53	30 008 13.16
	400	4	6.4	16	20 to 36	537	53	30 008 13.16
	500	4	8	20	20 to 36	537	53	30 008 13.20
	630	4	10.1	20	20 to 36	537	53	30 008 13.20
	800	5	12.9	20	20 to 36	537	53	30 008 13.20
	800	6	12.9	20	20 to 36	537	53	30 008 13.20
	1000	5	16.1	31.5	20 to 36	537	67	30 016 13.31.5
	1000	6	16.1	31.5	20 to 36	537	67	30 016 13.31.5
	1250	5	20.1	40	20 to 36	537	67	30 016 13.40
	1250	6	20.1	40	20 to 36	537	67	30 016 13.40
	1600	5	25.7	40	20 to 36	537	67	30 016 13.40
	1600	6	25.7	40	20 to 36	537	67	30 016 13.40
	2000	5	32.1	63	20 to 36	537	85	30 024 43.63 ¹⁾
	2000	6	32.1	63	20 to 36	537	85	30 024 43.63 ¹⁾
	2500	5	40.1	80	20 to 36	537	85	30 024 43.80 ¹⁾
2500	6	40.1	80	20 to 36	537	85	30 024 43.80 ¹⁾	

1) For voltages up to and including 30 kV, HHD-BSSK fuse-links are used for 1600 kVA, 2000 kVA and 2500 kVA.
For voltages up to and including 36 kV, HHD-BSSK fuse-links are used for 2000 kVA and 2500 kVA.

Components

Cable-type current transformers 4MC7033 and 4MC4_30

Features

- According to IEC/EN 61869-1 and -2/VDE 0414-9-1 and -2
- Designed as ring-core current transformers, 1-pole
- Free of dielectrically stressed cast-resin parts (due to design)
- Insulation class E
- Inductive type
- Secondary connection by means of a terminal strip in the panel.

Installation

The mounting location is outside the switchgear vessel, around the cable at the panel connection or at the bushings of the cable connection (option for current transformer type 4MC4_30 in circuit-breaker panel); installation on the cable on site.

Note: Installation inside or underneath the panel depending on the panel type and the overall transformer height.

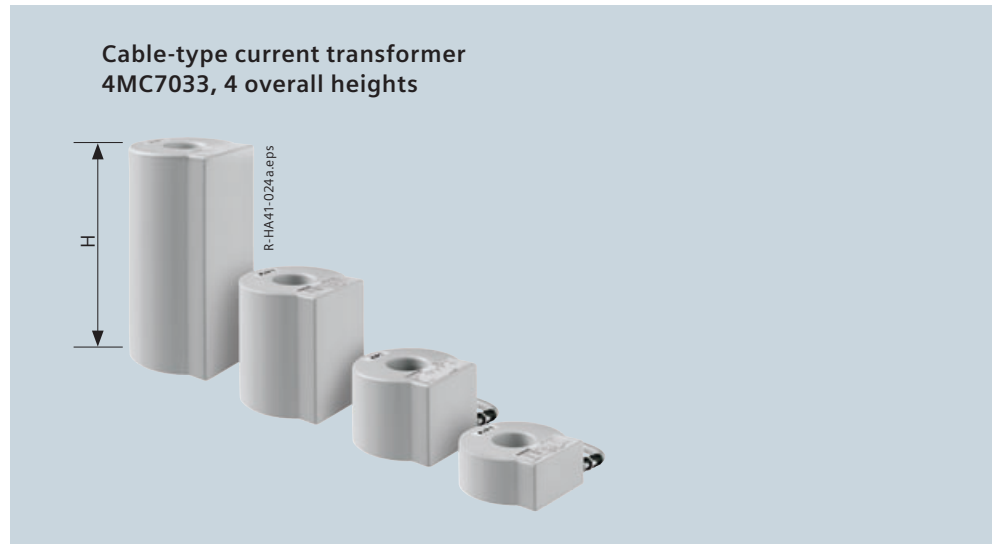

Technical data

Cable-type current transformer 4MC7033

Primary data

Highest voltage for equipment U_m	0.72 kV
Rated current I_N	20 A to 600 A
Rated short-duration power-frequency withstand voltage (winding test)	3 kV
Rated short-time thermal current I_{th}	up to 20 kA/3 s
Rated continuous thermal current I_D	$1.2 \times I_N$
Transient overload current	$1.5 \times I_D/1$ h or $2 \times I_D/0.5$ h
Rated dynamic current I_{dyn}	$2.5 \times I_{th}$

Secondary data

Rated current	1 A or 5 A, optionally: multiratio			
Measuring core	Class	0.2	0.5	1
	Overcurrent factor	with-out	FS5	FS10
Rating		2.5 VA to 30 VA		
Protection core	Class	10 P	5 P	
	Overcurrent factor	10	20	30
	Rating	1 VA to 30 VA		

Dimensions

Overall height H, mm depending on core data	65	110	170	285
Outside diameter	150 mm			
Inside diameter	55 mm			
For cable diameter	50 mm			

Other values on request

Technical data

Cable-type current transformer and current transformer on the bushing, 4MC4_30

Primary data

Highest voltage for equipment U_m	0.72 kV
Rated current I_N	50 A to 600 A
Rated short-duration power-frequency withstand voltage (winding test)	3 kV
Rated short-time thermal current I_{th}	up to 20 kA/3 s
Rated continuous thermal current I_D	$1.2 \times I_N$
Transient overload current	$1.5 \times I_D/1$ h or $2 \times I_D/0.5$ h
Rated dynamic current I_{dyn}	$2.5 \times I_{th}$

Secondary data

Rated current	1 A or 5 A	
Measuring core	Class	0.2 to 1
	Overcurrent factor	FS 5, FS 10
	Rating	2.5 VA to 30 VA
Protection core	Class	5 P or 10 P
	Overcurrent factor	10 to 30
	Rating	2.5 VA to 30 VA

Dimensions

Overall height H, mm	50	100	170	214
Outside diameter	190 mm			
Inside diameter	106 mm			
For cable diameter	100 mm			

Other values on request

Features

- According to IEC/EN 61869-1 and -3/ VDE 0414-9-1 and -3
- 1-pole, plug-in design
- Inductive type
- Connection with plug-in contact
- Safe-to-touch due to metal enclosure
- Secondary connection by means of plugs inside the panel
- For outside-cone system type C
- Voltage transformers at the cable connection can be disconnected from the main circuit for cable testing without being removed
- Busbar voltage transformers designed for up to 80% of the rated short-duration power-frequency withstand voltage at rated frequency (option).

Installation

- Mounting location:
 - Arranged above the switchgear vessel in individual panels type L; connection directly at the busbar
 - Arranged below the switchgear vessel in individual panels type L; can be switched off through SF₆-insulated disconnecting facility in the switchgear vessel.

Plug-in voltage transformer 4MU1



Technical data

for type 4MU1

Primary data

Highest voltage for equipment $1.2 \times U_n$	
Rated voltage U_r	Operating voltage U_n
kV	$kV/\sqrt{3}$
36	24.0
	25.0
	25.8
	27.6
	30.0
	33.0
	34.5
	35.0

Secondary data

Rated voltage	1 st winding	100/ $\sqrt{3}$
		120/ $\sqrt{3}$
	Auxiliary winding (option)	100/3
		110/3
		120/3
Rated long-time current (8 h)	6 A	Class
Rating in VA up to	25	0.2
	60	0.5
	150	1.0

Components

Current transformers 4MA76 and voltage transformers 4MR56 for air-insulated billing metering panels

Features

Current transformer 4MA76

- According to IEC/EN 61869-1 and -2 / VDE 0414-9-1 and -2
- Dimensions according to DIN 42600-5
- Designed as indoor block-type current transformer, 1-pole
- Cast-resin insulated
- Insulation class E
- Secondary connection by means of screw-type terminals.

Voltage transformer 4MR56

- According to IEC/EN 61869-1 and -3 / VDE 0414-9-1 and -3
- Dimensions according to DIN 42600-3
- Designed as indoor voltage transformer, 1-pole
- Cast-resin insulated
- Insulation class E
- Secondary connection by means of screw-type terminals.

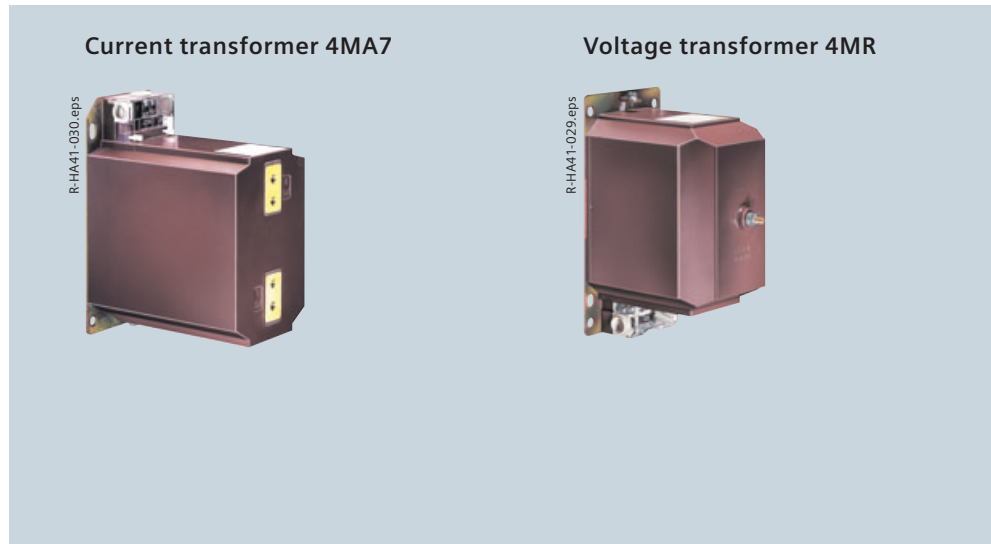

Technical data

Current transformer 4MA76, 1 pole

Primary data

Highest voltage for equipment U_m	36 kV
Rated short-duration power-frequency withstand voltage U_d	70 kV
Rated lightning impulse withstand voltage U_p	170 kV
Rated current I_N	
Rated short-time thermal current I_{th}	20 A to 600 A
Rated continuous thermal current I_D	$1.2 \times I_N$
Rated dynamic current I_{dyn}	max. $2.5 \times I_{th}$

Secondary data

Rated current	1 A or 5 A			
Measuring core	Class	0.2	0.5	1
	Overcurrent factor	with-out	FS5	FS10
	Rating	2.5 VA to 30 VA		
Protection core	Class	5 P or 10 P		
	Overcurrent factor	10		
	Rating	2.5 VA to 30 VA		

Other values on request

Technical data

Voltage transformer 4MR56, 1 pole

Primary data

Highest voltage for equipment	$1.2 \times U_n$ resp. max. 36 kV
Rated voltage (8 h) = $1.9 \times U_n$	
Rated voltage U_r	Operating voltage U_n
kV	$kV/\sqrt{3}$
36	24.0
	25.0
	25.8
	27.6
	30.0
	33.0
	34.5
	35.0

Secondary data

Rated voltage in V	1 st winding	100/ $\sqrt{3}$
		110/ $\sqrt{3}$
		120/ $\sqrt{3}$
	Auxiliary winding (option)	100/3
		110/3
		120/3
Rating in VA up to		Class
	20	0.2
	60	0.5
	100	1.0

Other values on request

Common features

- According to IEC 60044-8 (low-power current transformers)
- Example for available secondary devices that can be connected:
 - SICAM FCM
 - 7SJ81

Current sensors

(make Zelisko)

The current sensors are inductive current transformers whose secondary winding delivers a voltage signal through a precision shunt. At the rated primary current, this is 225 mV. Depending on their version, the sensors have a dual accuracy class; the output signal can be equally used for measuring, protection and, if required, earth-fault detection. The outgoing leads of the sensors are directly connected to the secondary device (SICAM FCM, 7SJ81).



Ring-core current sensor
SMCS-JW 1001



Ring-core current sensor
SMCS/T-JW 1002, divisible



Ring-core current sensor
GAE120/SENS-JW 1003 for
earth-fault detection, divisible

Technical data

	SMCS-JW1001	SMCS/ T-JW1002	GAE120/ SENS-JW1003
--	-------------	-------------------	------------------------

Primary data

Highest voltage for equipment U_n	0.72/3 kV	0.72/3 kV	0.72/3 kV
Rated current I_N	300 A ¹⁾	300 A ¹⁾	60 A
Rated short-time thermal current I_{th}	20 kA 1 s	20 kA 1 s	20 kA 1 s

Secondary data

Output signal	225 mV	225 mV	225 mV
Measuring	Class	0.5; 1; 3	1; 3
	Overcurrent factor	–	–
Protection	Class	5P	5P
	Overcurrent factor	10 20	10; 20
Earth-fault detection	Class	–	–
	Angle error	–	–
	Composite error e	–	–
Rated burden	≥ 20 kOhm	≥ 20 kOhm	≥ 20 kOhm

Dimensions and installation

Overall height, depending on the overcurrent factor	28 mm	up to 56 mm	53 mm	130 mm (incl. mounting plate)
External dimensions in mm	128 × 106		111 × 106	242 × 226
Inside diameter in mm	82		55	120
Mounting location	Cable plug ²⁾		On the cable	On the cable
Usable for panel widths in mm	430, 500, 590	430, 500, 590	430, 500, 590	430, 500, 590

1) Usable up to $2 \times I_N = 600$ A (output signal 2×225 mV) at constant accuracy class and half overcurrent factor

2) Mounting location at the bushings around the screened cable plug

Components

Voltage sensors

Common features

- According to IEC 60044-7 (low-power voltage transformers)
- Example for available secondary devices that can be connected:
 - SICAM FCM
 - 7SJ81

Voltage sensors

(make Zelisko)

The voltage sensors are resistor dividers which provide an output signal of $3.25 V/\sqrt{3}$ at the rated primary voltage. The outgoing leads of the sensors are directly connected to the secondary device (SICAM FCM, 7SJ81).



Sensor SMVS-UW1001

Technical data

Sensor SMVS-UW1001

Primary data

Highest voltage for equipment U_m	$1.2 \times U_n$
Rated voltage (8 h)	$1.9 \times U_n$
Rated voltage U_r	36 kV
Operating voltage U_n	30 kV

Secondary data

Rated voltage	$3.25 V/\sqrt{3}$
Class	0.5; 1; 3
Rated burden	200 kOhm \pm 1 %

Installation

Mounting location	On the screened cable plugs make Nexans type M400TB and M440TB
-------------------	--

Features

- Access to the cable compartment only if the feeder has been disconnected and earthed
- Bushings according to DIN EN 50181 with outside cone and bolted connection M16 as interface type C, or plug-in contact as interface type B (option in transformer feeder).

Connection of

- Cable T-plugs with bolted contact M16 for 630 A
- Cable elbow plugs or cable T-plugs with plug-in contact for 400 A (option in transformer panel)
- Thermoplastic-insulated cables (1-core and 3-core cables).

Option

- Mounted cable clamps on cable bracket.

Cable plugs

- As screened (semi-conductive) design independent of the site altitude.

Surge arresters

- Pluggable on cable T-plug or T-adapter
- The switchgear depth can be extended when surge arresters are mounted (depending on the make and type)
- Surge arresters recommended if, at the same time,
 - the cable system is directly connected to the overhead line,
 - the protection zone of the surge arrester at the end tower of the overhead line does not cover the switchgear.

Cable compartment

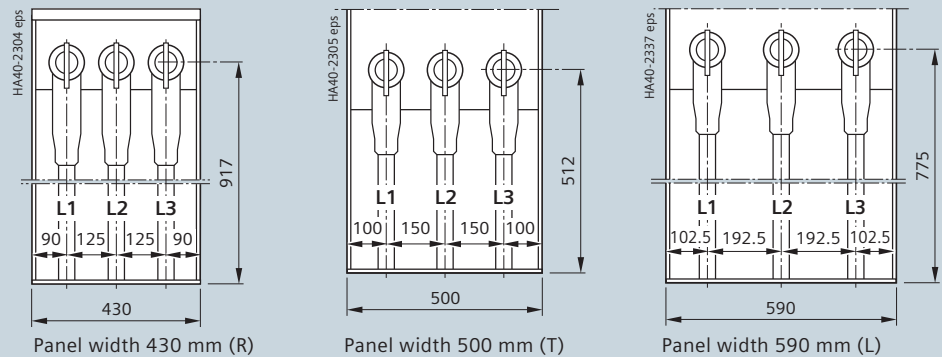

Connection options

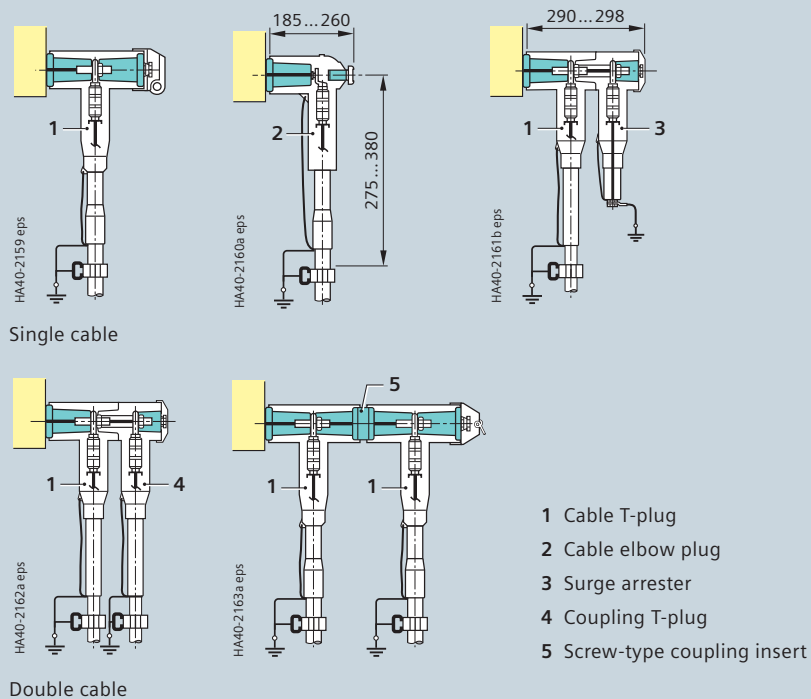

Components

Cable connection

Cable plugs for single cable connection

Cable type	Cable T-plug / cable elbow plug			
	Make	Type	Cross-section mm ²	Comment
Thermoplastic-insulated cables 36 kV according to IEC 60502-2 and VDE 0276 Part 620				
1-core cable, PE and XLPE-insulated N2YSY (Cu) and N2XSY (Cu) or NA2YSY (Al) and NA2XSY (Al)	Nexans	M400 LR/G ¹⁾	50 to 240	EPDM with semi-conductive layer
		M400 TE/G ¹⁾	50 to 240	EPDM with semi-conductive layer
		M400 TB/G	50 to 240	EPDM with semi-conductive layer
		M440 TB/G	300 to 630	EPDM with semi-conductive layer
		M430 TB/G	50 to 240	EPDM with semi-conductive layer
		M484 TB/G	50 to 630	EPDM with semi-conductive layer
		M480 TB/G	50 to 300	EPDM with semi-conductive layer
	Südkabel	SET 36-B ¹⁾	70 to 300	Silicone with semi-conductive layer (optionally with metal housing)
		SET 36	70 to 300	Silicone with semi-conductive layer (optionally with metal housing)
		SEHDT33	300 to 500	Silicone with semi-conductive layer (optionally with metal housing)
	nkt cables	CB36-400 ¹⁾	25 to 300	Silicone with semi-conductive layer
		CB36-630	25 to 300	Silicone with semi-conductive layer (optionally with metal housing)
		CB36-630 (1250)	400 to 630	Silicone with semi-conductive layer
	TE Connectivity	RSTI-68xx	25 to 300	Silicone with semi-conductive layer, with capacitive measuring point
		RSTI-69xx	300 to 630	Silicone with semi-conductive layer, with capacitive measuring point
	Prysmian	FMCT-400-X ¹⁾	25 to 300	EPDM with semi-conductive layer
		FMCTs-400-X	25 to 300	EPDM with semi-conductive layer
	Cooper Power Systems	DT436	25 to 240	EPDM with semi-conductive layer
	3 M Germany	94-EE 705-6/-XX	70 to 400	EPDM with semi-conductive layer
3-core cable, PE and XLPE-insulated N2YSY (Cu) and N2XSY (Cu) or NA2YSY (Al) and NA2XSY (Al)	Nexans	M400 TB/G	50 to 240	EPDM with semi-conductive layer, in combination with distribution kit
		M430 TB/G	50 to 240	EPDM with semi-conductive layer, in combination with distribution kit
	Südkabel	SET 36	70 to 300	Silicone with semi-conductive layer (optionally with metal housing), in combination with distribution kit
		SEHDT33	300 to 500	Silicone with semi-conductive layer (optionally with metal housing), in combination with distribution kit
	nkt cables	CB36-630	25 to 300	Silicone with semi-conductive layer (optionally with metal housing), in combination with distribution kit
	TE Connectivity	RSTI-68xx	25 to 300	Silicone with semi-conductive layer, with capacitive measuring point, in combination with distribution kit RSTI-TRF0x
	Prysmian	FMCTs-400-X	25 to 300	EPDM with semi-conductive layer, in combination with distribution kit
	Cooper Power Systems	DT436	25 to 240	EPDM with semi-conductive layer, in combination with distribution kit
	3 M Germany	94-EE 705-6/-XX	70 to 400	Silicone with semi-conductive layer, in combination with distribution kit

Larger cable cross-sections and other cable T-plugs or cable elbow plugs on request

1) Cable T-plug or cable elbow plug with plug-in contact for interface type B

Number of cables per panel and phase	Make	Conductor cross-section ¹⁾ mm ²	Elbow connectors	Coupling inserts / coupling plugs	Surge arresters	Coupling unit	According to standard
			plugged in	plugged in	Arresters		

• Transformer feeder with outside-cone interface type B

1	Nexans	50 to 240	1 × M400LR/G	–	–	–	IEC
---	--------	-----------	--------------	---	---	---	-----

Number of cables per panel and phase	Make	Conductor cross-section ¹⁾ mm ²	Cable T-plugs	Coupling inserts/ coupling plugs	Surge arresters	Coupling unit	According to standard
			plugged in	plugged in	Arresters		

• Transformer feeder with outside-cone interface type B

1	Nexans	50 to 240	1 × M400TE/G	–	–	–	IEC
	Südkabel	50 to 300	1 × SET 36-B	–	–	–	IEC
	nkt cables	25 to 300	1 × CB 36-400	–	–	–	IEC
	Prysmian	25 to 300	1 × FMCT-400	–	–	–	IEC

Number of cables per panel and phase	Make	Conductor cross-section ¹⁾ mm ²	Cable T-plugs	Coupling inserts/ coupling plugs	Surge arresters	Coupling unit	According to standard
			bolted	bolted	Arresters		

• Transformer feeder with outside-cone interface type C

• Ring-main feeder • Circuit-breaker feeder • Cable feeder

1	Nexans	50 to 240	1 × M400TB/G	–	400PB-10-SA-xxx ²⁾	–	IEC
		50 to 240	1 × M430TB/G	–	300SA-10-xxx	–	IEC
		50 to 300	1 × M480TB/G	–	800SA-10-xxx	–	IEC
		35 to 630	1 × M484TB/G	–	800SA-10-xxx	–	IEC
		300 to 630	1 × M440TB/G	–	400PB-10-SA-xxx ²⁾	–	IEC
	Südkabel	70 to 300	1 × SET 36	–	–	–	IEC
		300 to 500	1 × SEHDT 33	–	1 × MUT 33 ²⁾	1 × KU 33	IEC
	nkt cables	25 to 300	1 × CB 36-630	–	1 × CSA 36-10	–	IEC
		400 to 630	1 × CB 36-630 (1250)	–	1 × CSA 36-10	–	IEC
	TE Connectivity	50 to 300	1 × RSTI-68xx	–	1 × RSTI-CC-68SAxx10	–	IEC
		300 to 630	1 × RSTI-69xx	–	–	–	IEC
	Prysmian	25 to 300	1 × FMCTs-400-x	–	–	–	IEC
	Cooper Power Systems	25 to 240	1 × DT436-x-x	–	–	–	IEC
	3M	400 to 630	1 × 94-EE 705-6/xxx	–	–	–	IEC
2	Nexans	50 to 240	2 × M400TB/G ²⁾	1 × M400CP	–	–	IEC
		50 to 240	1 × M430TB/G	1 × M300PB/G	300SA-10-xxx ¹⁾	–	IEC
		50 to 300	1 × M480TB/G	1 × M804PB/G	800SA-10-xxx	–	IEC
		35 to 630	1 × M484TB/G	1 × M804PB/G	800SA-10-xxx ¹⁾	–	IEC
		300 to 630	2 × M440TB/G ²⁾	1 × M440CP	–	–	IEC
	Südkabel	300 to 500	2 × SEHDT33 ²⁾	1 × KU33	–	–	IEC
	nkt cables	25 to 300	1 × CB 36-630	1 × CC 36-630	1 × CSA 36-10 ²⁾	–	IEC
		400 to 630	1 × CB 36-630 (1250)	1 × CC 36-630 (1250)	1 × CSA 36-10 ²⁾	–	IEC
	TE Connectivity	50 to 300	1 × RSTI-68xx	1 × RSTI-CC-68xx	1 × RSTI-CC-68SAxx10 ²⁾	–	IEC
		300 to 630	1 × RSTI-69xx ¹⁾	1 × RSTI-CC-69xx ¹⁾	–	–	IEC

1) If this plug combination is used, or with a surge arrester, a 105 mm deeper cable compartment cover is necessary

2) If this plug combination is used, or with a surge arrester, a 250 mm deeper cable compartment cover is necessary

Components

Cable connection for single and double cables with surge arresters

Deep cable compartment cover

To increase the mounting depth in the cable compartment, deep cable compartment covers can be ordered optionally. The assignment to selected types of cable plugs and cable plug/surge arrester combinations is given in the following tables.

For circuit-breaker panels with current transformer on the bushing and/or voltage transformer at the cable connection, the illustration on the following page applies.

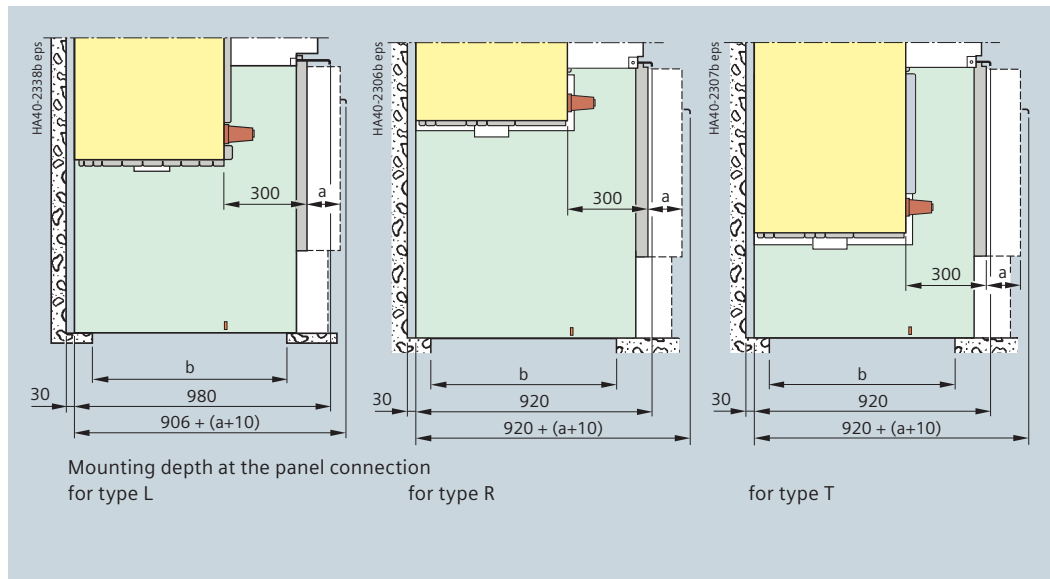

Cable plugs for double cable connection

Double cable connection			Connection combination			Deep cable compartment cover	
Make	Serial no.	Cable plug (type)	Design	Arrangement	Mounting depth (mm)	Deeper by a (mm)	Depth of floor opening b (mm)
Nexans	1	M430TB/G + M300PB/G	Screened	K + K	290	–	756
	2	2 × M400TB/G with coupling insert M400CP	Screened	K + K	505	250	1006
	3	M480TB/G + M804PB/G	Screened	K + K	290	–	756
	4	M484TB/G + M804PB/G	Screened	K + K	290	–	756
	5	2 × M440TB/G with coupling insert M440CP	Screened	K + K	505	250	1006
Südkabel	6	2 × SEHDT33 with coupling insert KU33	Screened	K + K	530	250	1006
nkt cables	7	CB 36-630 + CC 36-630	Screened	K + K	300	–	756
	8	CB 36-630(1250) + CC 36-630(1250)	Screened	K + K	300	–	756
TE Connectivity	9	RSTI-68xx + RSTI-CC-68xx	Screened	K + K	295	–	756
	10	RSTI-69xx + RSTI-CC-69xx	Screened	K + K	315	105	861
Cable plug + surge arrester			Connection combination			Deep cable compartment cover	
Make	Serial no.	Cable plug (type)	Design	Arrangement	Mounting depth (mm)	Deeper by a (mm)	Depth of floor opening b (mm)
Nexans	1	M430TB/G + 300SA	Screened	K + Ü	290	–	756
	2	M400TB/G + 400PB	Screened	K + Ü	410	250	1006
	3	M480TB/G + 800SA	Screened	K + Ü	290	–	756
	4	M484TB/G + 800SA	Screened	K + Ü	290	–	756
	5	M440TB/G + 400PB	Screened	K + Ü	410	250	1006
	6	M480TB/G + M804PB/G + 800SA	Screened	K + K + Ü	400	105	861
	7	M430TB/G + M300PB/G + 300SA	Screened	K + K + Ü	400	105	861
	8	M484TB/G + M804PB/G + 800SA	Screened	K + K + Ü	400	105	861
Südkabel	9	SEHDT33 + MUT 33 with coupling insert KU33	Screened	K + Ü	505	250	1006
nkt cables	10	CB 36-630 + CSA 36-10	Screened	K + Ü	300	–	756
	11	CB 36-630(1250) + CSA 36-10	Screened	K + Ü	300	–	756
	12	CB 36-630 + CC 36-630 + CSA 36-10	Screened	K + K + Ü	410	250	1006
	13	CB 36-630(1250) + CC 36-630(1250) + CSA 36-10	Screened	K + K + Ü	410	250	1006
TE Connectivity	14	RSTI-68xx + RSTI-CC-68SAxx	Screened	K + Ü	295	–	756
	15	RSTI-68xx + RSTI-CC-68xx + RSTI-CC-68SAxx	Screened	K + K + Ü	407	250	1006

K = Cable plug

Ü = Surge arrester

Deep cable compartment cover

To increase the mounting depth in the cable compartment, deep cable compartment covers can be ordered optionally. The assignment to selected types of cable plugs and cable plug/surge arrester combinations is given in the following tables.

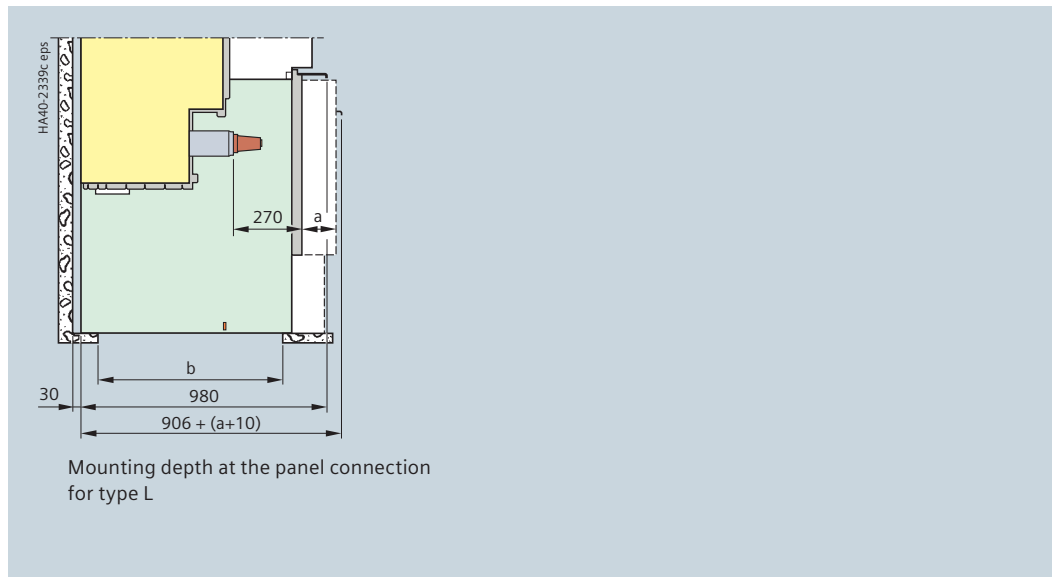

Cable plugs for double cable connection

Double cable connection			Connection combination			Deep cable compartment cover	
Make	Serial no.	Cable plug (type)	Design	Arrangement	Mounting depth (mm)	Deeper by a (mm)	Depth of floor opening b (mm)
Nexans	1	M430TB/G + M300PB/G	Screened	K + K	290	105	861
	2	2 × M400TB/G with coupling insert M400CP	Screened	K + K	505	250	1006
	3	M480TB/G + M804PB/G	Screened	K + K	290	105	861
	4	M484TB/G + M804PB/G	Screened	K + K	290	105	861
	5	2 × M440TB/G with coupling insert M440CP	Screened	K + K	505	250	1006
nkt cables	6	CB 36-630 + CC 36-630	Screened	K + K	300	105	861
	7	CB 36-630(1250) + CC 36-630(1250)	Screened	K + K	300	105	861
TE Connectivity	8	RSTI-68xx + RSTI-CC-68xx	Screened	K + K	295	105	861
	9	RSTI-69xx + RSTI-CC-69xx	Screened	K + K	315	105	861
Cable plug + surge arrester			Connection combination			Deep cable compartment cover	
Make	Serial no.	Cable plug (type)	Design	Arrangement	Mounting depth (mm)	Deeper by a (mm)	Depth of floor opening b (mm)
Nexans	1	M430TB/G + 300SA	Screened	K + Ü	290	105	861
	2	M400TB/G + 400PB	Screened	K + Ü	410	250	1006
	3	M480TB/G + 800SA	Screened	K + Ü	290	105	861
	4	M484TB/G + 800SA	Screened	K + Ü	290	105	861
	5	M440TB/G + 400PB	Screened	K + Ü	410	250	1006
	6	M480TB/G + M804PB/G + 800SA	Screened	K + K + Ü	400	250	1006
	7	M430TB/G + M300PB/G + 300SA	Screened	K + K + Ü	400	250	1006
	8	M484TB/G + M804PB/G + 800SA	Screened	K + K + Ü	400	250	861
Südkabel	9	SEHDT33 + MUT 33 with coupling insert KU33	Screened	K + Ü	505	250	1006
nkt cables	10	CB 36-630 + CSA 36-10	Screened	K + Ü	300	105	861
	11	CB 36-630(1250) + CSA 36-10	Screened	K + Ü	300	105	861
	12	CB 36-630 + CC 36-630 + CSA 36-10	Screened	K + K + Ü	410	250	1006
	13	CB 36-630(1250) + CC 36-630(1250) + CSA 36-10	Screened	K + K + Ü	410	250	1006
TE Connectivity	14	RSTI-68xx + RSTI-CC-68SAxx	Screened	K + Ü	295	105	861
	15	RSTI-68xx + RSTI-CC-68xx + RSTI-CC-68SAxx	Screened	K + K + Ü	407	250	1006

K = Cable plug

Ü = Surge arrester

Components

Cable testing

Cable testing

- For cable, ring-main cable and circuit-breaker feeders
- Disassembly of the switchgear cables not necessary
- Measuring bolts can be connected following the removal of the protective cap and/or the end stopper of the cable plug
- The switchgear is suitable for the following cable test voltages:

Rated voltage of switchgear	Cable test voltage ¹⁾		
	U_{ct} (DC)	U_{ct} (AC)	VLF 0.1 Hz ²⁾
U_r	kV	kV	kV
36	72	57	57
Test duration	15 min	60 min	60 min

- Additional important data for cable testing are included
 - In the installation and operating instructions for the 8DJH 36 switchgear
 - In the standards IEC/EN 62271-200/VDE 0671-200, HD 620 S2/VDE 0276-620, HD 621 S1/VDE 0276-621
 - In the cable and cable plug manufacturer information.

Cable testing

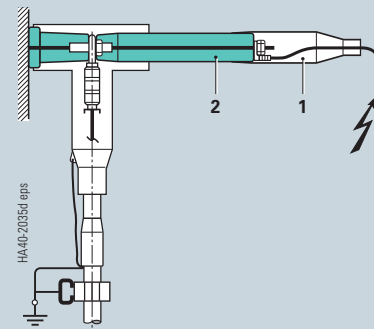

Cable testing at the cable T-plug (example)

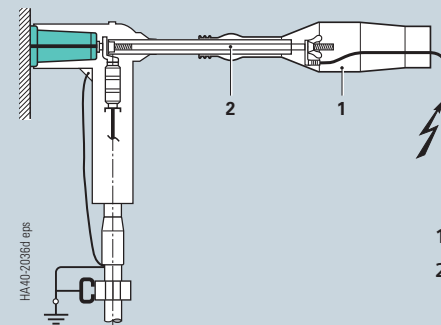

Cable testing at the cable elbow plug (example)

- 1 Insulating cap
- 2 Measuring bolt

1) Further values on request

2) VLF = Very low frequency

Standard interlocks

- Three-position switch: Disconnecting function against earthing function
- Access to cable compartment is generally only possible if
 - the feeder is isolated
 - and
 - the feeder is earthed ("EARTHED" position).

For ring-main feeders

- Option: Closing lockout
Prevents switching the three-position switch-disconnector from "OPEN" position to "CLOSED" position when the cable compartment cover is removed.

For transformer feeders

- The three-position switch disconnector cannot be switched from "EARTHED" to "OPEN" position when the cable compartment cover/the HV HRC fuse compartment is open.

For circuit-breaker feeders

- Option: Closing lockout:
Prevents switching the three-position disconnector from "OPEN" position to "CLOSED" position when the cable compartment cover is removed
- Option: De-earthing lockout:
Prevents switching the three-position disconnector from "EARTHED" position to "OPEN" position when the cable compartment cover is removed.

Locking device for padlock

- Shackle diameter 12 mm
- Standard for transformer feeders (stored-energy mechanisms)
- Option for ring-main feeders (spring-operated mechanisms)
- Three-position switch-disconnector lockable at the operating mechanism in any desired switch position.

Key-operated interlock (option)

- With cylinder locks from selected manufacturers
- For the basic functionalities:
 - Switch disconnector/disconnector
 - KF 1 Key free in OPEN
 - Key trapped in CLOSED
 - Earthing switch
 - KF 2 Key free in OPEN
 - Key trapped in EARTHED
 - Earthing switch
 - KF 3 Key free in EARTHED
 - Key trapped in OPEN.

These basic functionalities can be combined at will. Furthermore it is possible to integrate cylinder locks, e.g. of doors to transformer rooms, or external key boxes.

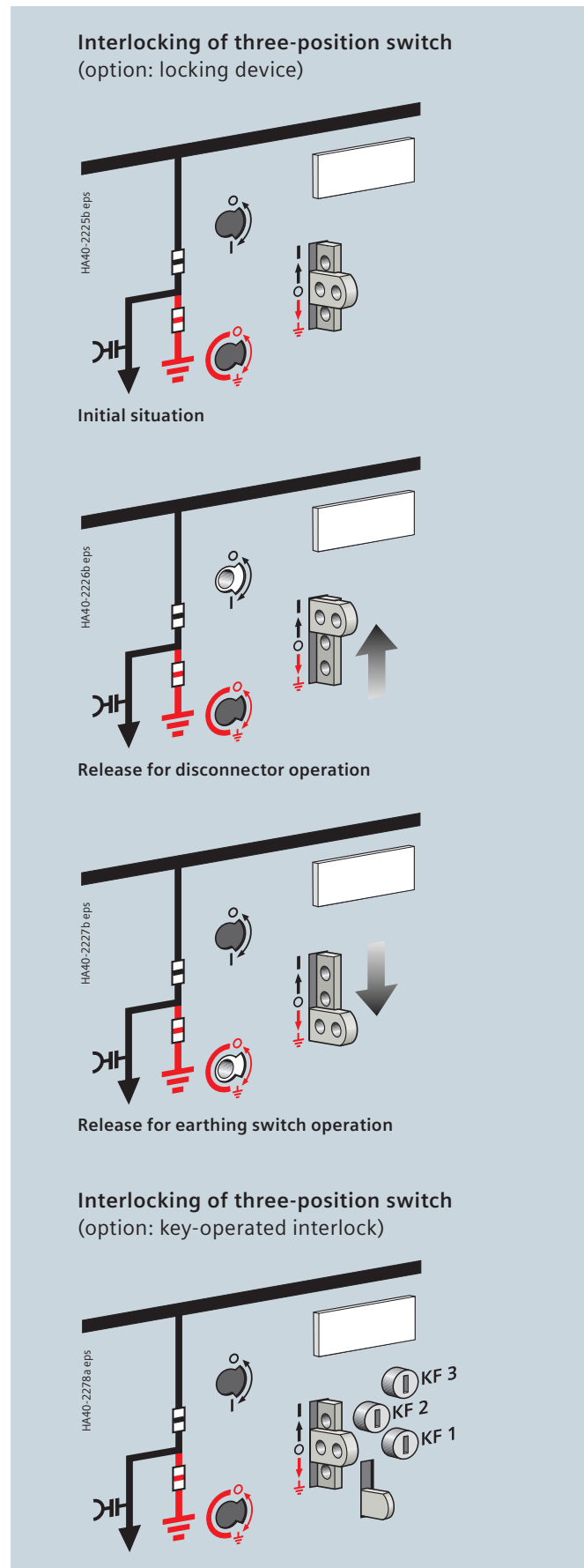

Components

Indicating and measuring equipment

Ready-for-service indicator

Features

- Self-monitoring; easy to read
- Independent of temperature and pressure variations
- Independent of the site altitude
- Only responds to changes in gas density
- Option: Alarm switch "1 NO + 1 NC" for remote electrical indication.

Mode of operation

For the ready-for-service indicator, a gas-tight measurement box is installed inside the switchgear vessel.

A coupling magnet, which is fitted to the bottom end of the measurement box, transmits its position to an outside armature through the non-magnetizable switchgear vessel. This armature moves the ready-for-service indicator of the switchgear.

While changes in the gas density during the loss of gas, which are decisive for the dielectric strength, are displayed, temperature-dependent changes in the gas pressure are not. The gas in the measurement box has the same temperature as that in the switchgear vessel.

The temperature effect is compensated via the same pressure change in both gas volumes.

Gas monitoring

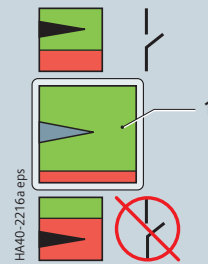

Indicator on control board:

- 1 Indication
green: ready for service
red: not ready for service

- 2 Measurement box
- 3 Magnetic coupling

Principle of operation

of gas monitoring with ready-for-service indicator

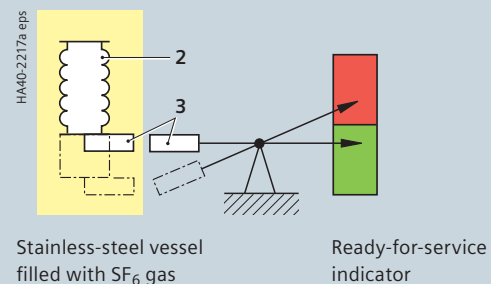

Stainless-steel vessel
filled with SF₆ gas

Ready-for-service
indicator

Voltage detecting systems according to IEC 61243-5 or VDE 0682-415

- For verification of safe isolation from supply
- HR or LRM detecting systems with plug-in indicator
- LRM detecting systems with integrated indicator type VOIS+, VOIS R+, CAPDIS-S1+, CAPDIS-S2+, WEGA 1.2 C, WEGA 2.2 C or WEGA 3.

Plug-in voltage indicator

- Verification of safe isolation from supply phase by phase
- Indicator suitable for continuous operation
- Measuring system and voltage indicator can be tested, repeat test according to local specifications and standards
- Voltage indicator flashes if high voltage is present.

VOIS+, VOIS R+

- Without auxiliary power
- Display indication "A1" to "A3" (see legend)
- Repeat test according to local specifications and standards
- With integrated 3-phase LRM test socket for phase comparison
- With integrated signaling relay (only VOIS R+).

Common features of CAPDIS-Sx+

- Without auxiliary power
- Integrated repeat test of the interfaces (self-monitoring)
- With integrated function test (without auxiliary power) by pressing the "Test" button
- Adjustable for different operating voltages (adjustable capacitance C2)
- With integrated 3-phase LRM test socket for phase comparison
- With connectable signal-lead test
- With overvoltage monitoring and signaling (1.2 times operating voltage).

CAPDIS-S1+

- Without auxiliary power
- Display indication "A1" to "A7" (see legend)
- Without ready-for-service monitoring
- Without signaling relay (without auxiliary contacts).

CAPDIS-S2+

- Display indication "A0" to "A8" (see legend)
- Only by pressing the "Test" pushbutton: "ERROR" indication (A8), e.g. in case of missing auxiliary voltage
- With ready-for-service monitoring (auxiliary power required)
- With integrated signaling relay for signals (auxiliary power required).

Indicators and detecting systems

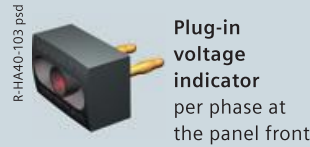

Integrated voltage detecting system CAPDIS-S1+, -S2+

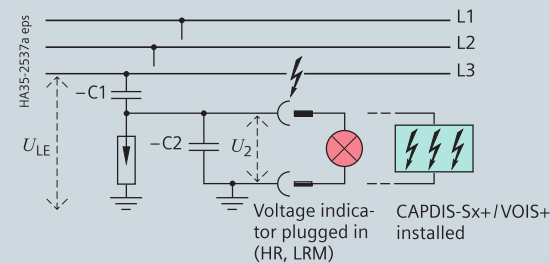

Voltage indication

via capacitive voltage divider (principle)

- C1 Capacitance integrated into bushing
 - C2 Capacitance of the connection leads and the voltage indicator to earth
- $U_{LE} = U_N / \sqrt{3}$ during rated operation in the three-phase system
- $U_2 = U_A =$ Voltage at the capacitive interface of the switchgear or at the voltage indicator

Symbols shown

	VOIS+, VOIS R+			CAPDIS-S1+			CAPDIS-S2+			
	L1	L2	L3	L1	L2	L3	L1	L2	L3	
A0							000			U=0 U=0 U=0
A1	⚡	⚡	⚡	⚡	⚡	⚡	⚡	⚡	⚡	U=0 U=0 U=0
A2										U=0 U=0 U=0
A3	⚡	⚡		⚡	⚡		⚡	⚡		U=0 U=0 U=0
A4				⚡	⚡	⚡	⚡	⚡	⚡	U=0 U=0 U=0
A5				000	000	000	000	000	000	U=0 U=0 U=0
A6				000	000	000	000	000	000	U=0 U=0 U=0
A7				000	000	000	000	000	000	U=0 U=0 U=0
A8							000	000	000	U=0 U=0 U=0

CAPDIS S2+: The red and green LEDs show the state of the relay contacts

○ LED doesn't light up

● LED lights up

U = Operating voltage

A0 CAPDIS-S2+: Operating voltage not present

A1 Operating voltage present

A2 – Operating voltage not present
– For CAPDIS-S2+: Auxiliary power not present

A3 Failure in phase L1, operating voltage at L2 and L3 (for CAPDIS-Sx+ also earth-fault indication)

A4 Voltage (not operating voltage) present

A5 Indication "Test" passed (lights up shortly)

A6 Indication "Test" not passed (lights up shortly)

A7 Overvoltage present (lights up permanently)

A8 "ERROR" indication, e.g. in case of missing auxiliary voltage

Components

Indicating and measuring equipment

WEGA 3

- Display indication "A1" to "A5"
- Integrated repeat test of the interface (self-monitoring)
- With integrated 3-phase LRM test socket for phase comparison.

WEGA 1.2 C

- Display indication "A1" to "A6" (see legend)
- Integrated repeat test of the interface (self-monitoring)
- With integrated function test (without auxiliary power) by pressing the "Display Test" button
- With integrated 3-phase LRM test socket for phase comparison.

WEGA 2.2 C

- Display indication "A0" to "A7" (see legend)
- Integrated repeat test of the interface (self-monitoring)
- With integrated function test (without auxiliary power) by pressing the "Display Test" button
- With integrated 3-phase LRM test socket for phase comparison
- With two integrated signaling relays (auxiliary power required *)).



Integrated voltage indicator WEGA 3



Integrated voltage indicator WEGA 1.2 C



Integrated voltage indicator WEGA 2.2 C

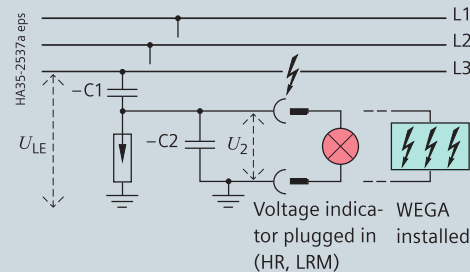

Voltage indication

via capacitive voltage divider (principle)

- C1 Capacitance integrated into bushing
- C2 Capacitance of the connection leads and the voltage indicator to earth

$U_{LE} = U_N / \sqrt{3}$ during rated operation in the three-phase system

$U_2 = U_A =$ Voltage at the capacitive interface of the switchgear or at the voltage indicator

Symbols shown

	WEGA 3			WEGA 1.2 C			WEGA 2.2 C			
	L1	L2	L3	L1	L2	L3	L1	L2	L3	
A0										U≠0 U=0
A1	⚡	⚡	⚡	⚡	⚡	⚡	⚡	⚡	⚡	U≠0 U=0
A2										U≠0 U=0
A3	⚡	⚡		⚡	⚡		⚡	⚡		U≠0 U=0
A4	⚡	⚡	⚡	⚡	⚡	⚡	⚡	⚡	⚡	U≠0 U=0
A5	⚡	⚡	⚡	⚡	⚡	⚡	⚡	⚡	⚡	U≠0 U=0
A6				⚡	⚡	⚡	⚡	⚡	⚡	U≠0 U=0
A7							⚡	⚡	⚡	U≠0 U=0

LC display gray: not illuminated

LC display white: illuminated

WEGA 2.2 C: The red and green LEDs show the state of the relay contacts

○ LED doesn't light up

● LED lights up

U = Operating voltage

A0 For WEGA 2.2 C:

Operating voltage not present, auxiliary power present, LCD illuminated

A1 Operating voltage present

For WEGA 2.2 C: Auxiliary power present, LCD illuminated

A2 Operating voltage not present

For WEGA 2.2 C: Auxiliary power not present, LCD not illuminated

A3 Failure in phase L1,

operating voltage at L2 and L3

For WEGA 2.2 C: Auxiliary power present, LCD illuminated

A4 Voltage present,

current monitoring of coupling

section below limit value

For WEGA 2.2 C: Auxiliary power present, LCD illuminated

A5 Indication "Display-Test" passed

For WEGA 2.2 C: Auxiliary power present, LCD illuminated

A6 Indication "Display Test" passed

For WEGA 2.2 C:

Auxiliary power present

A7 For WEGA 2.2 C: LCD for missing

auxiliary voltage is not illuminated

*) Shows the function of the relay via the LED indications (U=0, U≠0)

Verification of correct terminal-phase connections

- Verification of correct terminal-phase connections possible by means of a phase comparison test unit (can be ordered separately)
- Safe-to-touch handling of the phase comparison test unit by inserting it into the capacitive taps (socket pairs) of the switchgear.

Phase comparison test units according to IEC 61243-5 or VDE 0682-415

R-HA41-EPV.eps



Phase comparison test unit make Pfisterer, type EPV

as combined test unit (HR and LRM) for:

- Voltage detection
- Phase comparison
- Interface test
- Integrated self-test
- Indication via LED.

R-HA41-ORION-3-1.tif



Phase comparison test unit make Horstmann, type ORION 3.1

as combined test unit (HR and LRM) for:

- Phase comparison
- Interface testing at the switchgear
- Voltage detection
- Integrated self-test
- Indication via LED and acoustic alarm
- Phase sequence indication.

R-HA41-CAP-Phase.eps



Phase comparison test unit make Kries, type CAP-Phase

as combined test unit (HR and LRM) for:

- Voltage detection
- Repeat test
- Phase comparison
- Phase sequence test
- Self-test.

The unit does not require a battery.

R-HA41-ORION-M-1.tif



Phase comparison test unit make Horstmann, type ORION M1

as combined test unit (HR and LRM) for:

- Voltage detection
- Phase comparison
- Interface testing at the switchgear
- Integrated self-test
- Indication via display and acoustic alarm
- Phase sequence indication and status LED
- Measurement of interface current up to 25 μ A
- Measurement of phase angle from -180° to $+180^\circ$
- Measurement of harmonics up to 40th harmonic
- Securing the measured values via PC software (ORION explorer) and USB.

Components

Indicating and measuring equipment

Short-circuit/earth-fault indicators make Horstmann

Short-circuit/earth-fault indicator (option)

Ring-main, cable and circuit-breaker feeders can optionally be equipped with short-circuit or earth-fault indicators in different designs. The equipment features are shown in the table on page 47.

Short-circuit and earth-fault indicators reduce the downtimes of a power system by delimiting the fault locations in medium-voltage systems.

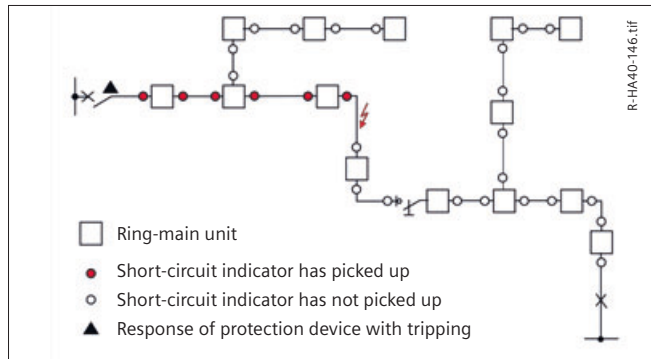

Short-circuit/earth-fault indicators can be used in all kinds of power systems. In impedance-earthed and solidly earthed systems, as well as in isolated and compensated (resonant-earthed) systems, earth-fault detection is also possible.

SIGMA 2.0 with basic functions

- Adjustable pickup values
- Phase-selective fault indication
- Reset of the fault indication: manually, automatically, from remote
- Earth-fault detection in impedance-earthed or solidly earthed systems
- Remote indication with relay contacts.

SIGMA D++ with directional function

- Directional short-circuit indication
- Directional earth-fault indication for all types of neutral treatment
- Unambiguous indication of the fault direction
- Monitoring with "SIGMA Explorer" software.

ComPass B 2.0 with monitoring

- Voltage detection via WEGA voltage detecting system and resistive sensor system for up to 4 devices
- High-precision current and voltage measurement up to 0.5 %
- Monitoring of the values: U, I, f, P, Q, S, E, $\cos \varphi$, load flow direction, power meter with direction
- Temperature measurement with PT100
- Limit value recording for U, I, P, Q, T
- Transfer of measured values, fault indications and events via RS485/MODBUS.

ComPass Bs 2.0 with control function

- Remote control of a switch-disconnector or circuit-breaker
- Freely programmable logic to define the switching conditions
- 6 binary inputs for recording relevant state information from the switchgear/substation.



EARTH ZERO



ALPHA E



SIGMA 2.0



SIGMA D++



ComPass B 2.0

All indicators (except ALPHA) use the same phase current sensors.

Short-circuit/ earth-fault indicators Horstmann	ALPHA M ALPHA E	SIGMA 2.0 SIGMA 2.0 AC / DC	SIGMA F+E 2.0 SIGMA F+E 2.0 AC / DC	SIGMA F+E 3 2.0 SIGMA F+E 3 2.0 AC / DC	SIGMA D	SIGMA D+	SIGMA D++	ComPass A 2.0	ComPass B 2.0	ComPass Bs 2.0	Earth Zero- EarthZeroFlag
Function											
Short circuit/earth fault	■ / ■	■ / ■	■ / ■	■ / ■	■ / ■	■ / ■	■ / ■	■ / ■	■ / ■	■ / ■	- / ■
Direction indication	-	-	-	-	■	■	■	-	■	■	-
Monitoring: U, I, f, P, Q, S, E, cos φ, load flow direction	-	-	-	-	-	-	-	■	■	■	-
Control of a CB or SD	-	-	-	-	-	-	-	-	-	■	-
Logic	-	-	-	-	-	-	-	-	-	■	-
Applicable for the following neutral treatments											
Impedance earthed	■	■	■	■	■	■	■	■	■	■	■
Solidly earthed	■	■	■	■	■	■	■	■	■	■	■
Isolated	■	■	■	■	■	■	■	■	■	■	-
Compensated	■	■	■	■	■	■	■	■	■	■	-
Short-circuit pickup values											
I>> Short-circuit current	400, 600, 800, 1000 A	200, 300, 400, 600, 800, 1000, 2000 A, self-adjustment			DIP: 200, 300, 400, 600, 800, 2000 A, self-adjustment Software (SW): 50 – 2000 A			20 – 2000 A		-	
tI>> Pickup delay	100 ms	40, 80 ms	40, 80, 200, 300 ms		DIP: 40, 80 ms, Software (SW): 40 ms – 60 s			40 ms – 60 s		-	
Earth-fault pickup values											
IES> Short-circuit-to-earth current	-	-	20, 40, 60, 80, 100, 120 or 160 A		DIP: off, 20, 40, 60, 80, 100, 120, 160 A, Software (SW): 20 – 1000 A			20 – 1000 A		25, 50, 75, 100 A	
IET> Transient earth fault	-	-	-	-	-	10 – 100 A	10 – 500 A	-	10 – 500 A	-	
IEP> Active residual current cos φ	-	-	-	-	-	5 – 200 A	5 – 200 A	-	1 – 200 A	-	
IEQ> Reactive current sin φ	-	-	-	-	-	5 – 200 A	5 – 200 A	-	1 – 200 A	-	
UNE> Permanent earth fault	-	-	-	-	-	-	-	-	1 – 100%	-	
ΔIE> Pulse location (pulse amplitude)	-	-	-	■	-	1 – 100 A	1 – 100 A	1 – 200 A		-	
Pickup delay	-	-	80, 200 ms	60, 80, 200, 300 ms	DIP: 80, 160 ms, Software (SW): 40 ms – 60 s			40 ms – 60 s		80, 160 ms	
Reset											
Manually / from remote	■ / - (M) ■ / ■ (E)	■ / ■	■ / ■	■ / ■	■ / ■	■ / ■	■ / ■	■ / ■	■ / ■	■ / ■	■ / -
Auto. time reset	■ (E)	■	■	■	■	■	■	■	■	■	■
Current / voltage recovery	-	-	-	■ / -	■ / ■	■ / ■	■ / ■	■ / -	■ / ■	■ / ■	- / ■
Test											
Manually / from remote	■ / -	■ / ■	■ / ■	■ / ■	■ / ■	■ / ■	■ / ■	■ / ■	■	■	■ / -
Communication											
Relay contact	1	1	2	3	4	4	4	4	4	4	1
Maintained / passing contact	adjustable	adjustable			adjustable			adjustable			adjustable
RS485 / MODBUS-RTU	-	-	-	-	-	-	-	■	■	■	-
USB connection	-	-	-	-	■	■	■	■	■	■	-
Parameterizing											
Manually / from remote	■ / -	■ / -	■ / -	■ / -	■ / -	■ / -	■ / -	■ / ■	■ / ■	■ / ■	■ / -
Supply											
Lithium cell, ≥ 20 years	■ (E)	■ / Capacitor (AC/DC)			■	■	■	■	■	■	■
Current-transformer operated	■	■	■	■	■	■	■ (not IET>)	-	-	-	■
External auxiliary voltage	-	24 – 230 V AC / DC (only AC / DC versions)		24 – 230 V AC / DC (SIG-MA F+E3 2.0 optional)	-	24 V AC, 24 – 60 V DC (possible)	24 – 230 V AC / DC (for IET>)	24 – 230 V AC / DC			-
Binary inputs											
Number	2	2	2	2	2	2	2	2	2	6	-
Current inputs											
Phase current	3	3	3	3	3	3	3	3	3 or 2	0	
Summation current	0	0	0	0	0	0 or 1	0 or 1	0	0 or 1	1	
Voltage inputs											
Capacitive	-	-	-	-	■	■	■	-	■	■	-
Resistive	-	-	-	-	-	-	-	-	■	■	-

Components

Indicating and measuring equipment

Short-circuit / short-circuit-to-earth and earth-fault indicators, make Kries

Ring-main, cable and circuit-breaker feeders can optionally be equipped with short-circuit or earth-fault indicators in different designs. The equipment features are shown in the table on the next page. The three most common types of faults in medium-voltage systems are earth faults in cables and switchgear, faults and overloads of distribution transformers, as well as short circuits in cables and switchgear. For fast fault location and minimization of downtimes, electronic fault indicators are used:

- Selective fault detection, and thus minimization of downtimes
- Reliable fault detection through electronic measured-value acquisition
- Remote indication of fault events and measured values.

Short-circuit and short-circuit-to-earth indicator IKI-20

- Universally adjustable
- Current-transformer supported battery version or auxiliary voltage versions available
- Extended commissioning and testing functions.

Short-circuit and earth-fault indicator IKI-20PULS

- Short-circuit detection same as IKI-20
- Earth-fault detection via pulse location in compensated systems.

Short-circuit and earth-fault indicator IKI-20C(PULS)

- Current-transformer operated (No battery, no auxiliary voltage)
- Optionally with pulse location for earth-fault detection in compensated systems.

Directional short-circuit and earth-fault indicator IKI-22

- Directional fault detection for all system types
- Directional detection combined with the voltage detecting system CAPDIS-Sx+.

Grid-Inspector IKI-50

- Directional measured-value acquisition
- Monitoring of values U, I, f, P, Q, S, E, cos φ , power factor, load flow direction (momentary value, mean value and min/max value, directional)
- Directional fault detection for all system types
- Switchgear control or automation through an integrated, programmable logic component
- Directional detection combined with the voltage detecting system CAPDIS-Sx+.

Options:

- One device controls two cable panels and the load flow total
- Directional detection combined with resistor dividers (accuracy 1.0 %)
- Early fault detection and detection of intermittent earth faults
- Telecontrol interface according to IEC 60870-5-104.

Short-circuit-to-earth indicator IKI-10light

- Earth-fault detection in systems with impedance-earthed neutral or temporarily impedance-earthed neutral
- Adjustable.



Short-circuit/ earth-fault indicators Kries	IKI-20B	IKI-20T	IKI-20U	IKI-20PULS	IKI-20C	IKI-20CPULS	IKI-22	IKI-50_1F	IKI- 50_1F_EW_ PULS	IKI-50_2F	IKI- 50_2F_EW_ PULS	IKI-10-light-P
Function												
Short-circuit indication	■	■	■	■	■	■	■	■	■	■	■	■
Earth-fault indication				■		■	■	■	■	■	■	
Short-circuit-to-earth indication ⁵⁾	■	■	■		■		■	■	■	■	■	■
Direction indication							■	■	■	■	■	
Applicable for the following neutral earthing options												
Impedance	■	■	■		■		■	■	■	■	■	■
Solid	■	■	■		■		■	■	■	■	■	■
Isolated	■	■	■		■	■	■	■	■	■	■	
Compensated	■	■	■	■	■		■	■	■	■	■	
Pickup current												
Short-circuit current	100, 200, 400, 600, 800, 1000, 2000 A				400, 600, 800, 1000 A		100, 200, 300, 400, 600, 800, 1000, 2000 A		100 ... 1000 A (steps of 100 A)			
Earth-fault current							Transient fault detection		4 ... 30 A (steps of 1 A)			
Short-circuit-to-earth current ⁵⁾	40, 80, 100, 150 A						40, 80, 100, 200 A		40 ... 200 A (steps of 10 A)		20, 40, 60, 80 A	
Pulse location									■		■	
Pickup time												
Short-circuit current	60, 80, 150, 200 ms				100 ms		60, 80, 150, 200 ms		60 – 1600 ms			
Short-circuit-to-earth current ⁵⁾	60, 80, 150, 200 ms				100 ms		60, 80, 150, 200 ms		60 – 1600 ms		70, 250 ms	
Earth-fault current					Pulse location		Pulse location		Transient fault detection		400 – 3000 ms	
Reset												
Manual	■	■	■	■	■	■	■	■	■	■	■	■
Automatic	■	■	■	■	■	■	■	■	■	■	■	■
From remote	■	■	■	■			■	■	■	■	■	■
Remote indication												
Passing contact	adjustable				■	■	■	adjustable				
Maintained contact	adjustable							adjustable				
Interface												
RS485/MODBUS								■	■	■	■	
IEC 60870-5-104 (option)								■	■	■	■	
Power supply												
Lithium battery	■						■					■
External auxiliary voltage		■	■	■			Only for transient fault detection	Buffered for 6 h by internal capacitor				■
Current inputs												
Phase current	3	3	3	3	3	3	3	3	3	6	6	–
Summation current	1	1	1	1		1			1 ¹⁾	0 ²⁾	0 ²⁾	1
Voltage inputs												
Capacitive							3	3	3	6	6	–
Resistive (option)							–	3	3	6	6	–
Release outputs												
Potential-free	1 – 3	1 – 3	1 – 3	1 – 3	2	2	4	4	4	4	4	1
Supplied by internal capacitor (option)								2 ³⁾	2 ³⁾	2 ³⁾	2 ³⁾	
Binary inputs												
Number	2 (test + reset)						2 (test + reset)	4	4	4	4	–

1) Optional for wattmetric detection of earth-fault direction

4) Momentary value, mean value and min / max value, directional

2) Creation of sum signal via 3 transformers mounted around the conductor 5) Short-circuit to earth = Earth fault in impedance-earthed system

3) 0.1 Ws, 24 V DC

Components

On request: Indicating and measuring equipment

Short-circuit / earth-fault indicator Siemens	SICAM FCM	SICAM FPI
Function		
Short-circuit indication	■	■
Earth-fault indication	■	■
Earth-fault function (impedance-earthed system)	■	■
Indication of direction, short-circuit / earth-fault	■	–
Undervoltage and overvoltage indication	■	–
Applicable for the following neutral earthing options		
Impedance	■	■
Solid	■	■
Isolated	■	■
Compensated	■	■
Pickup current		
Short-circuit current	50 ... 2000 A (steps of 1 A)	Type 1: 200 – 1200 A, type 2: 200 – 800 A (in 7 steps each)
Earth-fault current	1 ... 1000 A (steps of 1 A)	Type 1: 10 – 100 A, type 2: 40 – 300 A (in 7 steps each)
Pulse location	–	–
Pickup time		
Short-circuit current	40 ms < t < 60 s	< 500 ms adjustable
Earth-fault current	40 ms < t < 60 s	< 500 ms adjustable
Reset		
Manual	■	■
Automatic	■	■
From remote	■	■
Remote indication		
Passing contact	adjustable	–
Maintained contact	adjustable	2 binary outputs
Interface		
RS485/MODBUS	■	–
Power supply		
Lithium battery	■	■
External auxiliary voltage	■	–
Current inputs		
Phase current	3 (2) ¹⁾	3 optical
Summation current	0 (1) ¹⁾	1 optical
Voltage inputs		
Via resistor divider	3	–
Via integrated capacitive voltage indicator (optional)	3	–
Relay outputs		
Potential-free	2 ²⁾	2
Binary inputs		
Number	1	–

1) Measuring sensor 3+0 (summation current is calculated), measuring sensor 2+1 (phase L2 is calculated)
2) Optional



SICAM FCM

The short-circuit and earth-fault indicator SICAM FCM (Feeder Condition Monitor) with direction indication enables fast and precise fault location, thus reducing the downtimes in the power system. The possibility to determine and telecommunicate the values U, I, f, P, Q, S, E, cos φ and load flow direction supports efficient operational management and network planning.

- Usable in earthed, isolated and resonance-earthed systems
- Directional short-circuit and earth-fault detection
- Selective fault information with direction indication as a basis for "self-healing" applications
- Usable with current and voltage sensors according to IEC 60044 for precise measurement without calibration and adjustment to the primary values
- Alternatively usable with an integrated capacitive voltage detecting system
- Flexible earth-current detection as from 0.4 A
- Integrated MODBUS-RTU interface:
- Remote parameterization via SICAM A8000 and MODBUS
- Self-test function of the communication connection.

SICAM FPI (Fault Passage Indicator)

- Detection of short circuits and earth faults
- Indication of phase and earth faults via 4 separate LEDs
- Enhanced diagnostics, self and sensor cable diagnostics is supported
- Configurable binary outputs, for remote indication to SCADA via RTU for faults and for diagnostics.



SICAM FPI

Transformer monitor IKI-30 (make Kries)

Application with vacuum circuit-breaker

Protection of distribution transformers with ratings that cannot or should not be protected with HV HRC fuses:

- Tripping of the circuit-breaker in case of overload (delayed)
- Tripping of the circuit-breaker when the short-circuit current arises.



Application area

The transformer monitor IKI-30 is suitable for the following transformer ratings:

- Operating voltage 25 ... 35 kV: ≥ 400 kVA.

Features

- Current-transformer operated, alternatively auxiliary voltage 24 ... 230 V AC/DC
- Instrument transformers
 - Special cable-type current transformers
 - No direction-dependent installation required
 - No earthing of a transformer pole required
 - No short-circuit terminals required for maintenance
- C.t.-operated release (0.1 Ws)
- Optional shunt release for auxiliary voltage supply

- Mounting location
 - In the front operating mechanism box of the feeder panel
 - In the low-voltage compartment (option) of the circuit-breaker feeder
- Response performance
 - Definite-time overcurrent characteristic
 - Definite-time overcurrent characteristic for earth-fault protection
 - Inverse time-overcurrent characteristic
 - extremely inverse
 - normal inverse
 - Externally undelayed instantaneous tripping
- Self-test function
 - Display test LED (red)
 - Battery test (under load), LED (green)
 - Primary current test with tripping and with primary current injection into the instrument transformers
- Indication
 - LED indication for tripping (single flash: starting; double flash: tripping)
 - Reset after 2 h or automatically (after return of power) or manually with reset pushbutton
- Outputs
 - Tripping signal: 1 floating relay output (NC contact) for telecommunication as passing contact
 - Starting signal: 1 floating relay output (NC contact) – is activated as long as the starting criterion is reached, e.g. to block an upstream primary protection
 - 1 watchdog (relay)
 - 1 external tripping output for control of an existing release, e.g. via capacitor
 - Tripping output designed as impulse output for direct control of the c.t.-operated release
- Input
 - Remote tripping signal, control via floating external contact
 - Instantaneous tripping.

Components

Protection systems

Simple protection systems

As a simple protection for distribution transformers and circuit-breaker feeders, standard protection systems are available, consisting of:

- Current-transformer operated protection device with c.t.-operated release (low-energy 0.1 Ws)
 - Siemens SIPROTEC 7SJ45
 - Woodward/SEG WIC 1-2P, WIC 1-3P, WIP-1
- Protection device with auxiliary voltage supply with shunt release (f)
 - Siemens SIPROTEC 7SJ46
- Instrument transformer as
 - Cable-type current transformer (standard).

Mounting location

- In 200-mm-high top low-voltage unit (option) of the circuit-breaker feeder.

Multifunction protection (selection)

Application of simple protection systems

Operating voltage (kV)	Transformer rating (kVA)	
	7SJ45/7SJ46	WIC 1-2P
25	≥ 630 kVA	≥ 630 kVA
30	≥ 800 kVA	≥ 800 kVA
35	≥ 1000 kVA	≥ 1000 kVA

SIPROTEC Compact series, overcurrent protection SIPROTEC 7SJ80

- 9 programmable function keys
- 6-line display
- USB front port
- 2 additional communication ports
- IEC 61850 with integrated redundancy (electrical or optical)

SIPROTEC 5 series, overcurrent protection SIPROTEC 7SJ82

- Directional and non-directional time-overcurrent protection with additional functions
- Time optimization of the tripping times by directional comparison and protection data communication
- Frequency protection and rate-of-frequency-change protection for load shedding applications
- Overvoltage and undervoltage protection in all required variations
- Power protection, configurable as active or reactive power protection
- Control, synchrocheck and switchgear interlocking system
- Firmly integrated, electrical Ethernet port J for DIGSI
- Complete IEC 61850 (Reporting and GOOSE) via integrated port J
- Two optional, pluggable communication modules usable for different and redundant protocols (IEC 61850, IEC 60870-5-103, DNP3 (serial+TCP), Modbus RTU Slave, protection data communication).

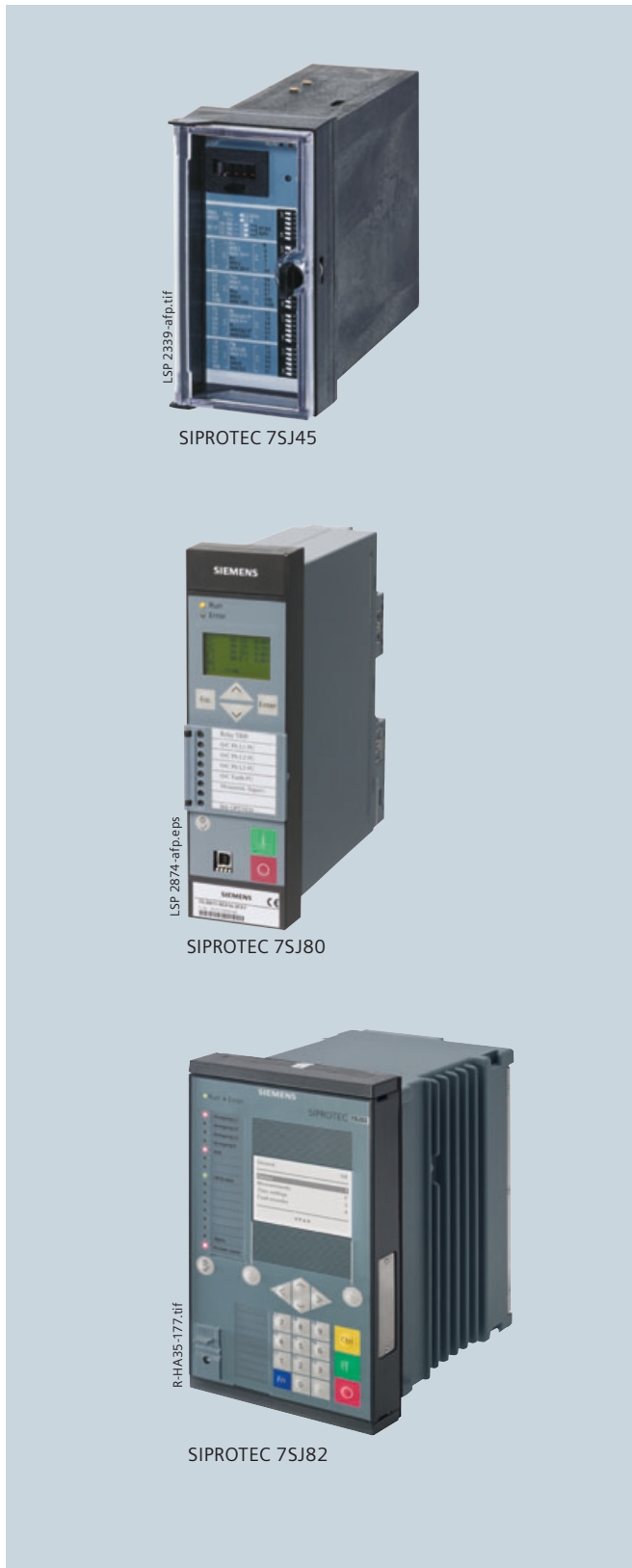

Other types and makes on request

Mounting location

- In the 400 mm or 600 mm high low-voltage compartment (option) of the feeders.

Equipment examples for the switchgear

8DJH 36 switchgear can be equipped with motor operating mechanisms, voltage detecting and measuring devices, short-circuit indicators, and further detection systems.

RTUs (Remote Terminal Units) can be optionally integrated inside the switchgear, in additional low-voltage compartments, or in a separate wall cubicle via a plug connection.

In this way, the switchgear fulfills all preconditions for integration in an intelligent network infrastructure. Depending on the purpose, different components for monitoring and control are used: These components can also be easily and quickly retrofitted at a later time. An equipment example for the switchgear is illustrated here.



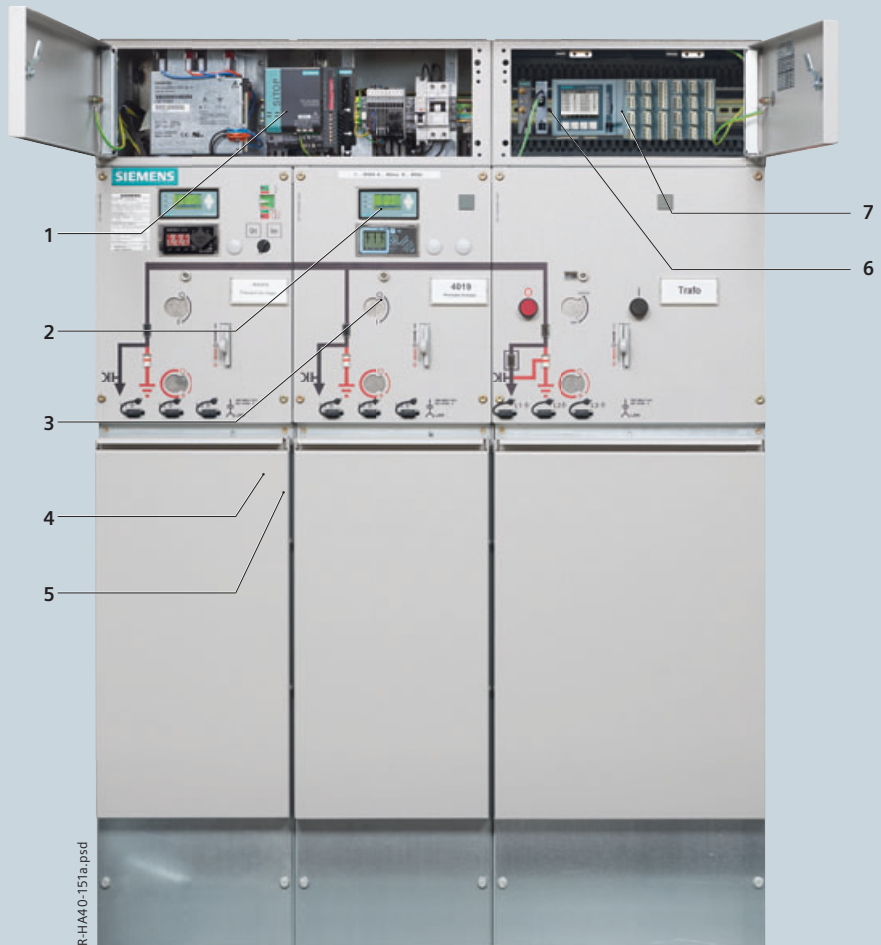

The integration

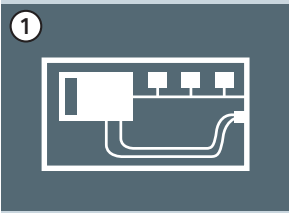
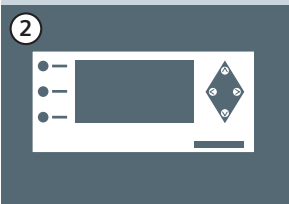
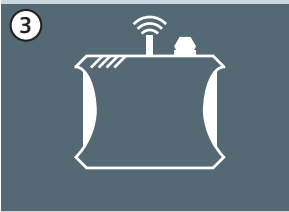

- 1 Uninterruptible power supply (UPS)
- 2 Intelligent SC indicators
- 3 Remotely controllable operating mechanisms
- 4 Current sensors
- 5 Voltage sensors
- 6 Communication modem
- 7 Remote terminal unit

Components

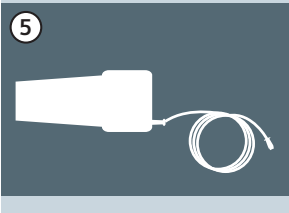
Intelligent transformer substation

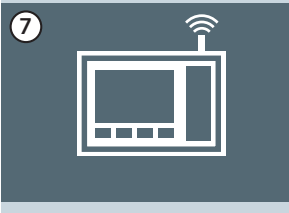
	Components	Function
	<p>Uninterruptible power supply (UPS) Depending on the requested bridging time in case of power failures, an uninterruptible power supply based on battery or capacitor modules is used.</p>	<p>The task of the UPS is to continue to ensure the communication and/or the possibility to telecontrol the transformer substation in case of power failure.</p>
	<p>Intelligent SC indicators Intelligent short-circuit and ground fault indicators with or without direction indication can be used in all grid types. For communication with the RTU, a Modbus RTU interface is available.</p>	<p>Intelligent short-circuit/ground fault direction indicators report short-circuits or ground faults in the medium-voltage distribution grid. Relevant measured values are acquired, allowing for an active load management in the distribution grid.</p>
	<p>Remotely controllable operating mechanisms Motor operating mechanisms inside the ring-main unit are available in original equipment manufacturer quality. If required, retrofitting is easily possible.</p>	<p>In order to reduce the reclosing times in case of fault, the switch-disconnectors or circuit-breakers are equipped with motor operating mechanisms for remote control.</p>
	<p>Current sensors Current sensors with low-power transformer technology are available as closed or divisible ring cores.</p>	<p>The current signal serves to detect short-circuits and ground faults, and can be used as a measured value for load flow control or for optimal utilization of the grid capacity.</p>
	<p>Voltage sensors Voltage sensors as resistor dividers are available as cast-resin plugs for insertion into the cable T-plug.</p>	<p>The voltage signal serves to detect the direction of the short-circuit or ground fault, and can be used as a measured value for load flow control or voltage regulation.</p>
	<p>Communication modem The selection of the communication modem to be used is determined by the selected or available telecommunication technology.</p>	<p>Communication modems are employed for safe data transmission from the remote terminal unit to the network control center using the selected telecommunication technology.</p>
	<p>Remote terminal unit The remote terminal unit (RTU) is equipped with binary inputs and outputs, various communication interfaces, and freely programmable user programs.</p>	<p>Inside the intelligent transformer substation, the RTU serves as a connecting element to the network control center. It collects all relevant signals and receives control commands, or works autonomously according to predetermined control or regulation algorithms.</p>

Features

- Overall heights
 - 200 mm, 400 mm, 600 mm
 - Option: Cover
- Partitioned safe-to-touch from the high-voltage part of the panel
- Installation on the panel
- Possible per feeder
- Option for all panel types, depending on the scope of the secondary equipment
- Customer-specific equipment
For accommodation of protection, control, measuring and metering equipment
- Separate wiring duct on the switchgear beside the low-voltage compartment (option)
- Door with hinge on the left (standard for heights of 200, 400 and 600 mm).

Low-voltage cables

- Control cables of the panel to the low-voltage compartment via multi-pole, coded module plug connectors
- Option: Plug-in bus wires from panel to panel in the separate wiring duct on the panel.

Low-voltage compartment (example 500 × 600 mm)

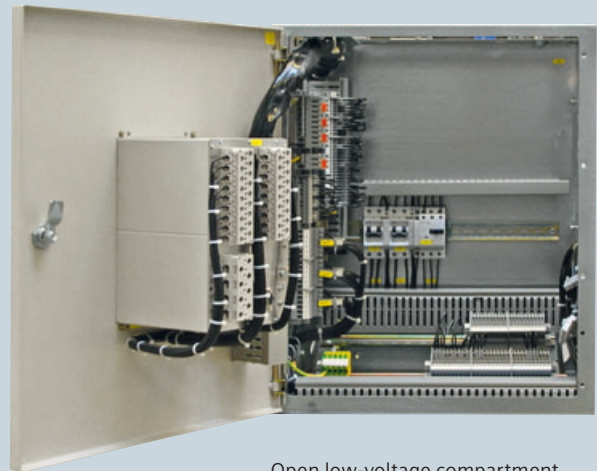

R:HA40-128.eps

Open low-voltage compartment with built-in equipment (option)

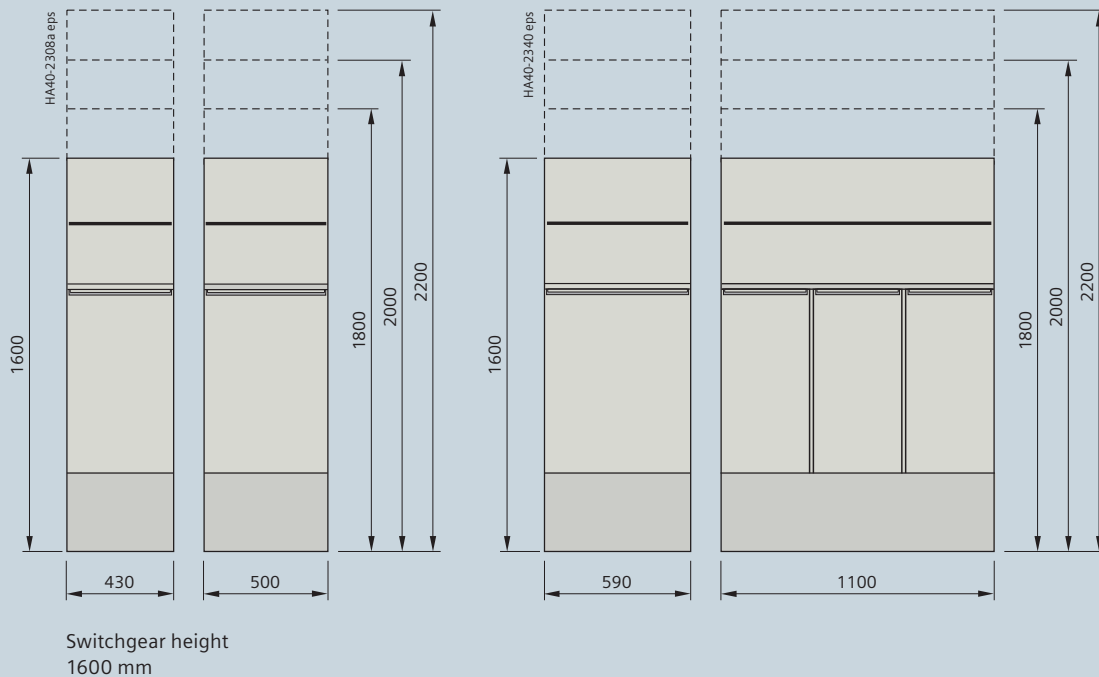

Dimensions

Room planning

Please observe the following for room planning and switchgear installation:

Switchgear installation

Wall-standing arrangement

- 1 row
- 2 rows (for face-to-face arrangement)
 - A wall distance of ≥ 30 mm applies to the metering panel in switchgear with billing metering panels, as well as in switchgear with pressure relief downwards and in switchgear with pressure relief duct. Then, the wall distance of the other panel types increases to ≥ 90 mm. In switchgear with pressure relief to the rear/upwards, billing metering panels have a wall distance of 90 mm. All other panel types have a wall distance of 150 mm.

Option: Free-standing arrangement

Pressure relief

The type of pressure relief selected has an effect on the size of the switchgear depth, and places requirements on the size of the cable basement and/or the room height. In case of pressure relief upwards, the room heights reproduced in the type test are decisive for the internal arc classification acc. to IEC/EN 62271-200/VDE 0671-200.

Door dimensions

The door dimensions have an influence on the size of the transport units (see page 63) and the factory assembly of panel groups, low-voltage compartments and pressure absorber systems. If required, this installation work can also be performed on site by the customer.

Switchgear fixing

- For floor openings and fixing points of the switchgear, see pages 60 to 62
- Foundations:
 - Steel girder construction
 - Reinforced-concrete floor.

Panel dimensions

See page 56 and 57.

Weight

For data, see page 64.

Local regulations and guidelines

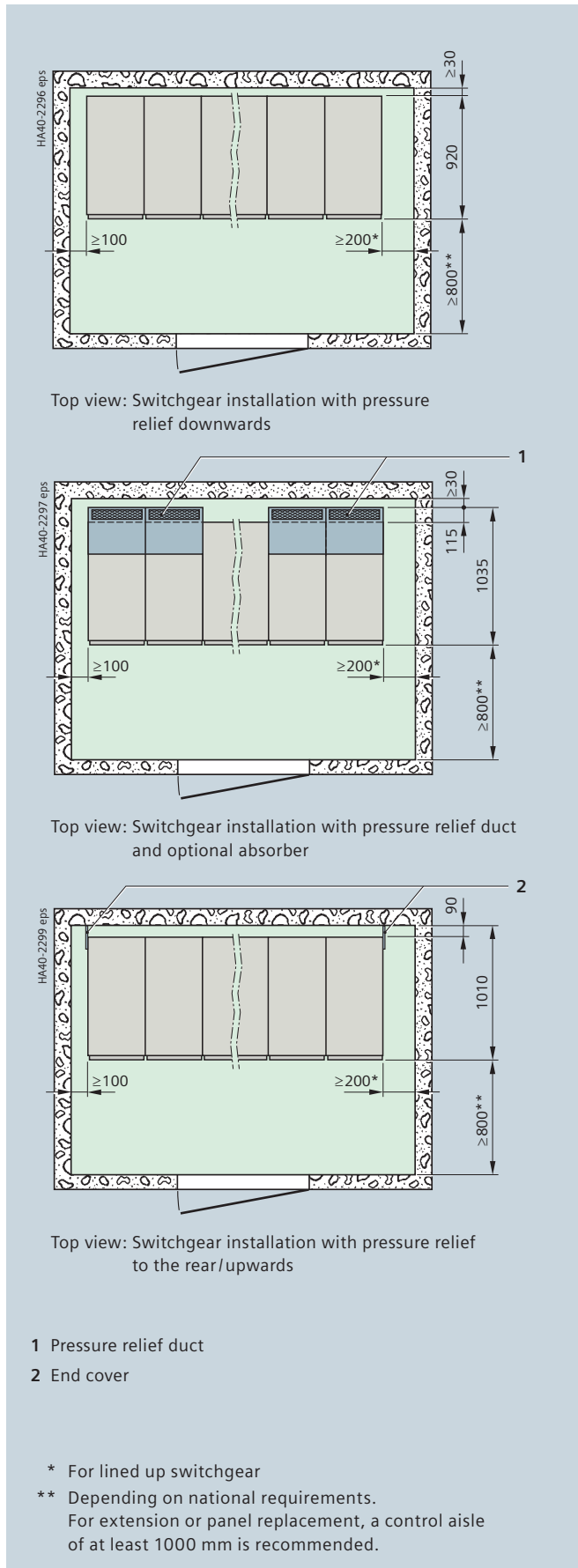

Pressure relief

The following type-tested versions of the pressure relief system are available for 8DJH 36 switchgear:

- Downwards into the cable basement (for individual panels and panel blocks, internal arc classification up to IAC A FL 20 kA/1 s or IAC A FLR 20 kA/1 s)
- To the rear/upwards (for individual panels and panel blocks, internal arc classification up to IAC A FL 20 kA/1 s)
- Upwards through rear pressure relief duct (for individual panels and panel blocks, internal arc classification up to IAC A FL 20 kA/1 s or IAC A FLR 20 kA/1 s)

- Upwards through rear pressure relief duct and additional absorber (for individual panels – except billing metering panels – and for panel blocks, internal arc classification up to IAC A FL 20 kA/1 s or IAC A FLR 20 kA/1 s).

Room heights

- Minimum room heights according to the table below
- As a difference to the minimum room heights according to the table, a minimum room height of 2200 mm applies to all pressure relief versions in circuit-breaker panels with busbar voltage transformers
- For billing metering panels with pressure relief to the rear/upwards and with rear duct, a minimum room height of 2400 is required.

Switchgear installation with pressure relief downwards (standard)

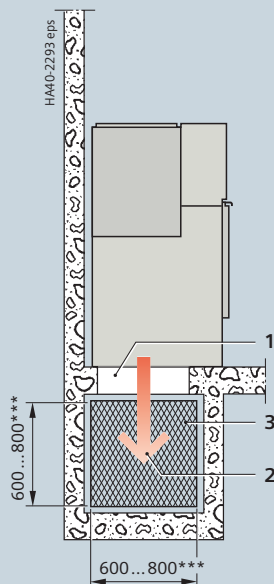

Switchgear installation with pressure relief to the rear/upwards (option)

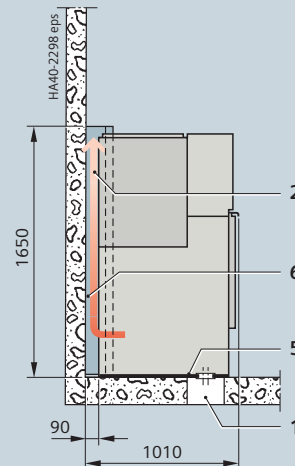

- 1 Floor opening
- 2 Direction of pressure relief
- 3 Expanded metal
- 4 Pressure relief with and without absorber and pressure relief duct directed upwards at the rear
- 5 Divided floor cover for cable insertion, installation on site
- 6 Termination plate

*** Total opening minimum 0.48 m²

Switchgear installation with pressure relief duct (option)

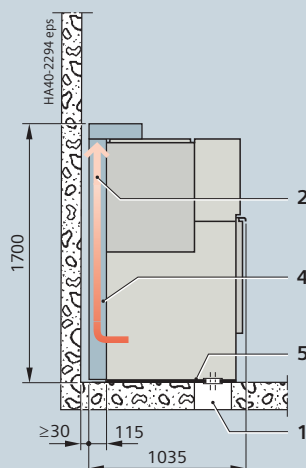

Switchgear installation with pressure relief duct and absorber (option)

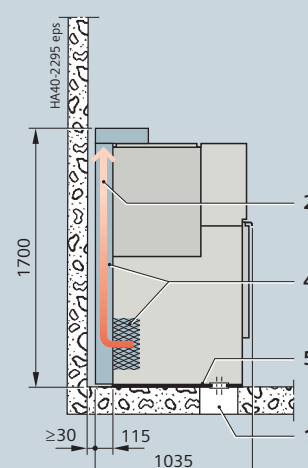

Room heights for pressure relief to the rear/upwards and for switchgear with rear pressure relief duct

Switchgear height	Room height
1650 mm	≥ 2000 mm
1700 mm	≥ 2000 mm

Dimensions

Individual panels and modules

Ring-main feeder type R

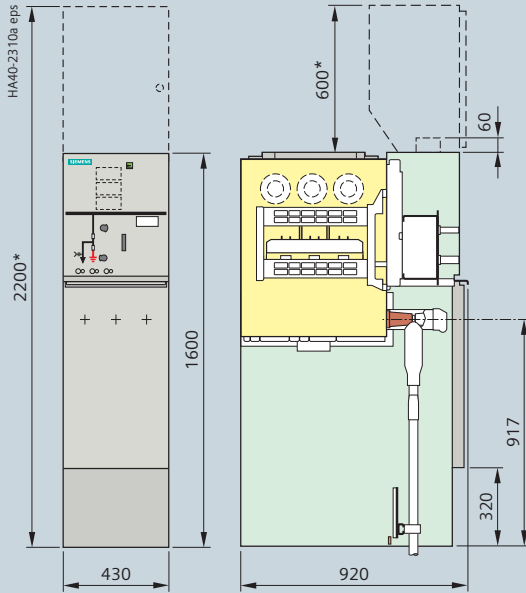

Cable feeder type K

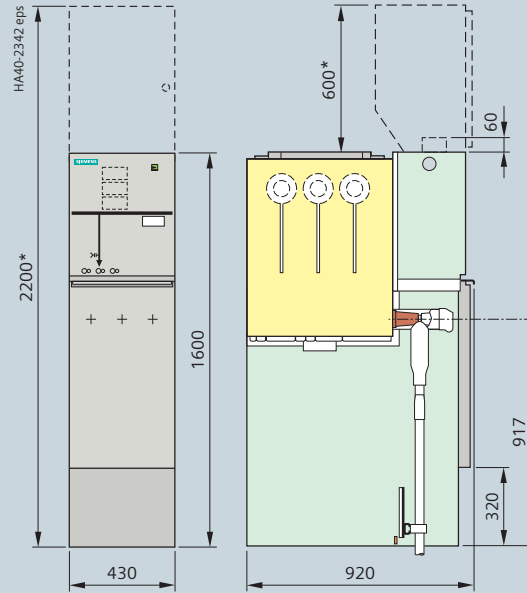

Transformer feeder type T

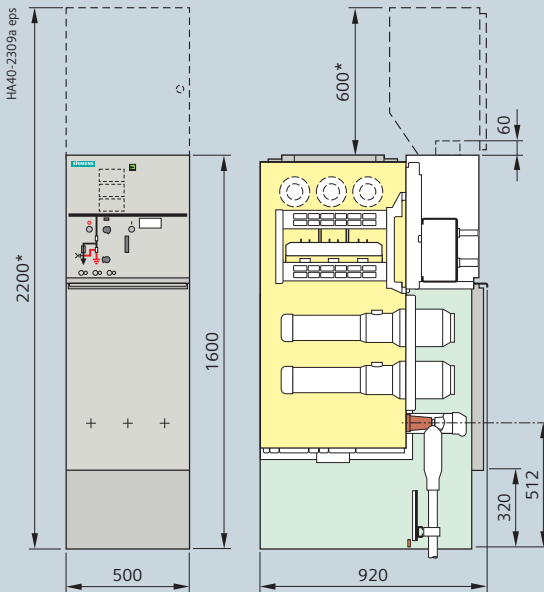

Circuit-breaker feeder type L

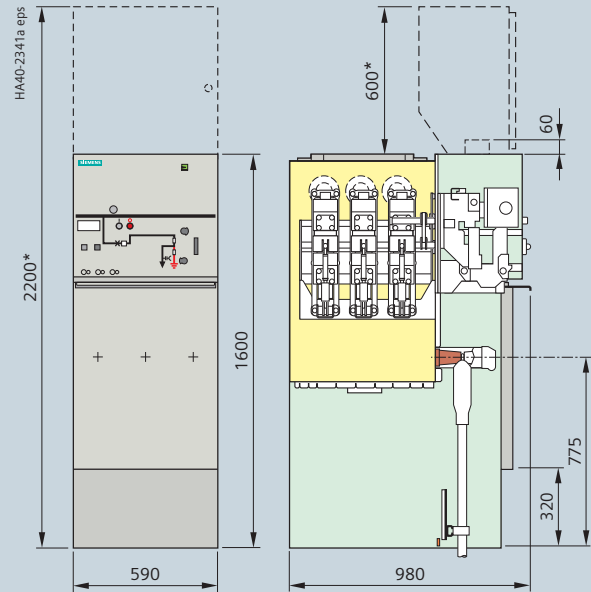

* Option: With low-voltage compartment

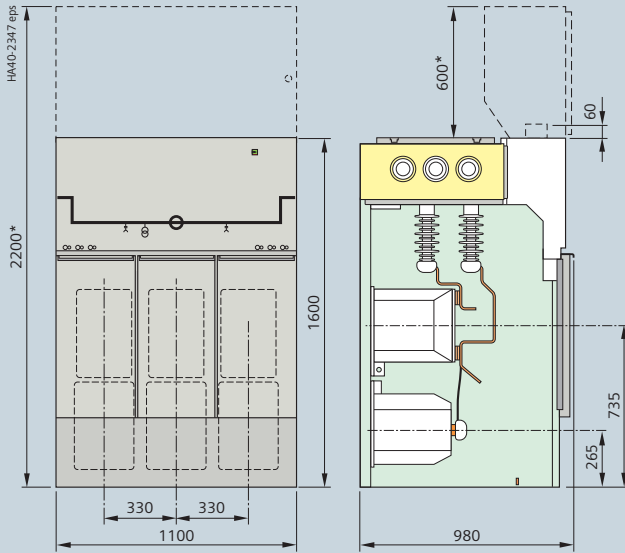

Connection: busbar – busbar

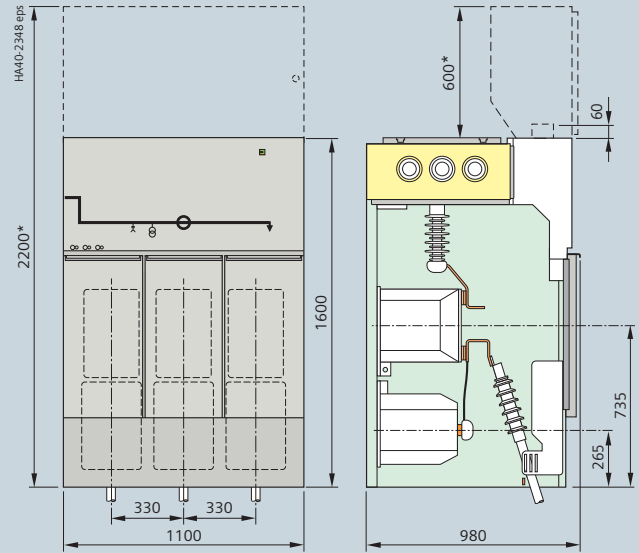

Connection: busbar on the left – cable on the right

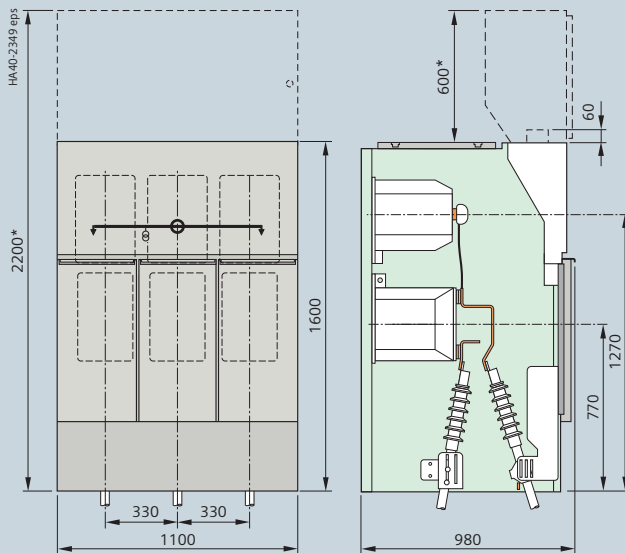

Connection: cable – cable

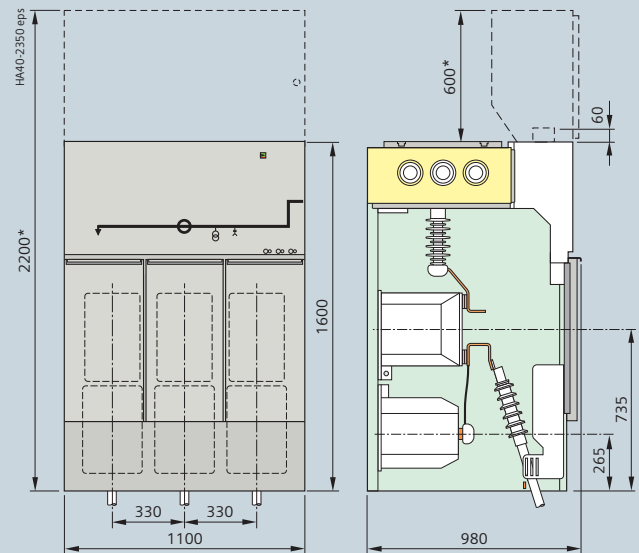

Connection: cable on the left – busbar on the right

* Option: With low-voltage compartment

Dimensions

Panel blocks

Versions with transformer feeders

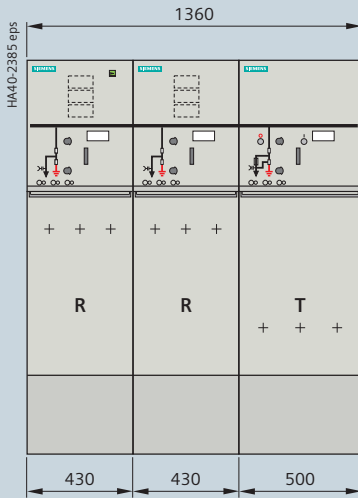

Panel block **RRT**

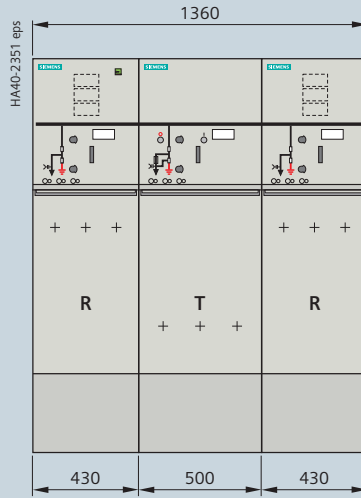

Panel block **RTR**

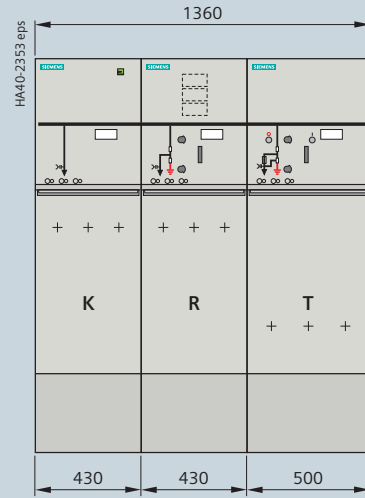

Panel block **KRT**

Versions with circuit-breaker feeders

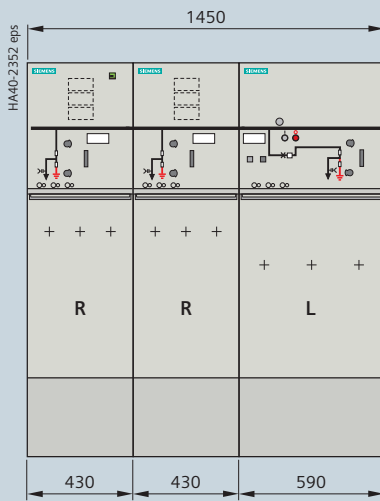

Panel block **RRL**

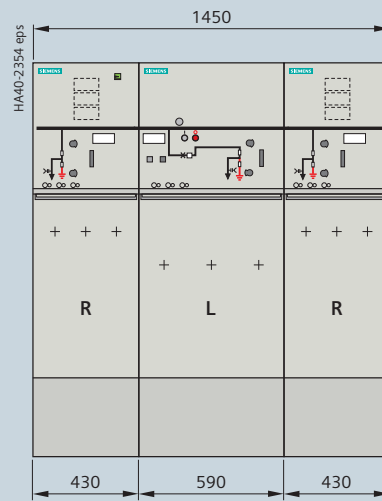

Panel block **RLR**

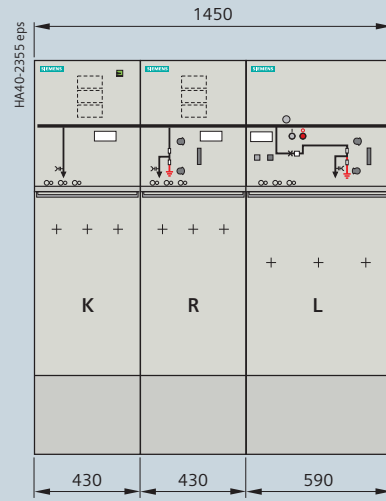

Panel block **KRL**

For further dimension data,
see individual panels and modules on page 11.

For floor openings and fixing points,
see page 60.

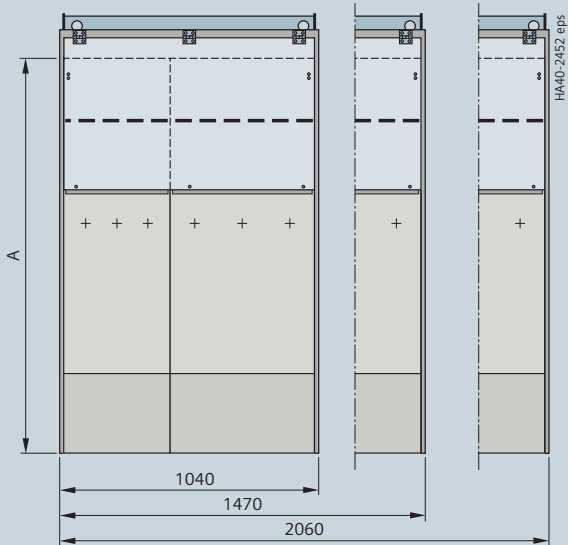

Outdoor enclosure with pressure relief upwards

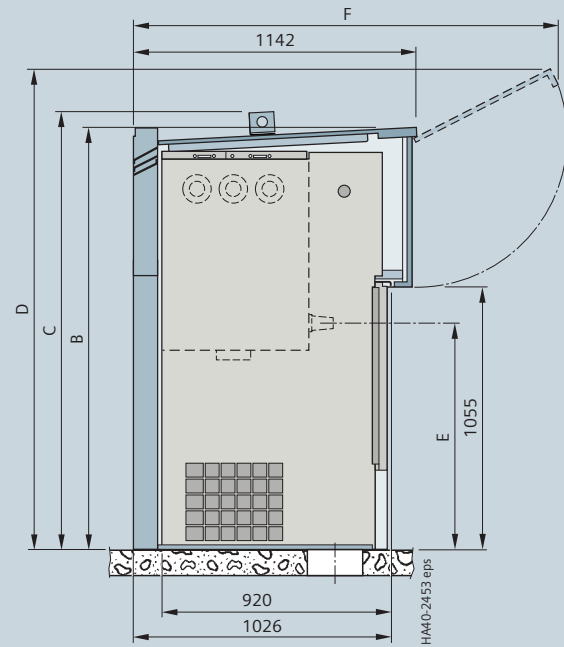

Outdoor enclosure with pressure relief upwards

Switchgear height	without low-voltage compartment	A	1600			
	with low-voltage compartment ¹⁾		-	1800	2000	2200
Low-voltage compartment ¹⁾		-	-	200	400	600
Enclosure height	without crane profile	B	1700	1875	2275	2275
	with crane profile (removable)	C	1760	1935	2335	2335
	Door open	D	1000	1000	1200	1400
Cable connection	Typical K, R	E	917			
	Typical T		512			
	Typical L		775			
Enclosure depth (roof level, with pressure relief duct)	Door while opening / closing	F	1725	1725	1925	2125

1) Option: With low-voltage compartment

Note: Maximum switchgear width = Enclosure width – 20 mm

Dimensions

Floor openings and fixing points

Ring-main panel/cable panel

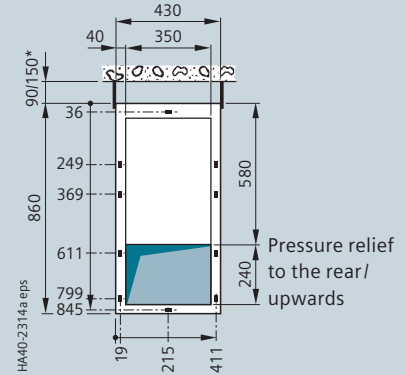
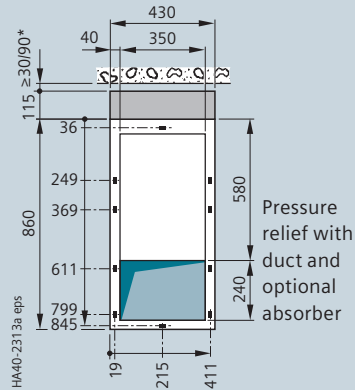
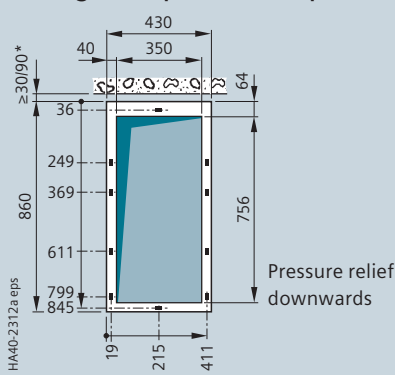

Transformer panel

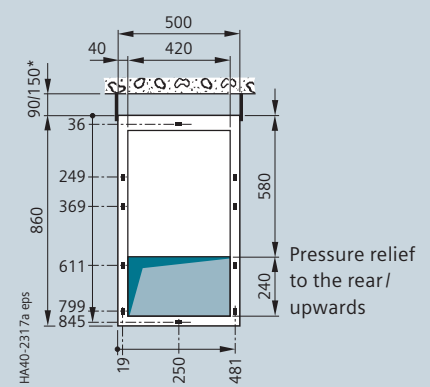
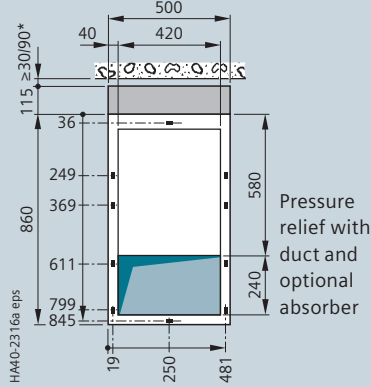
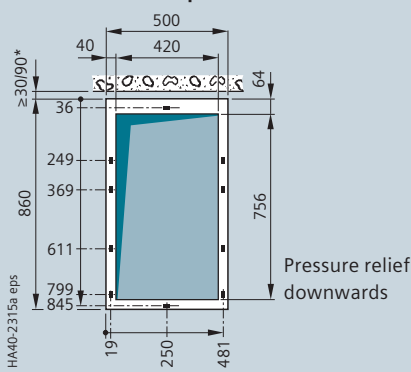

Circuit-breaker panel

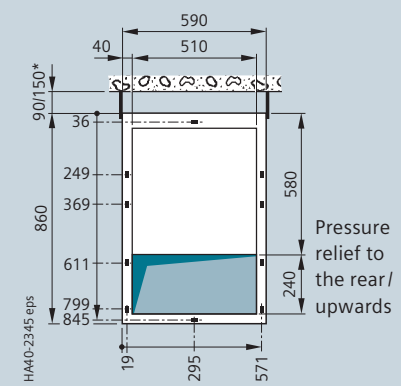
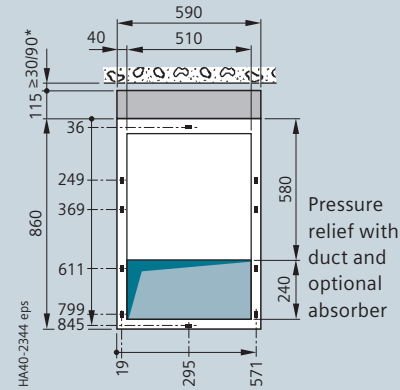
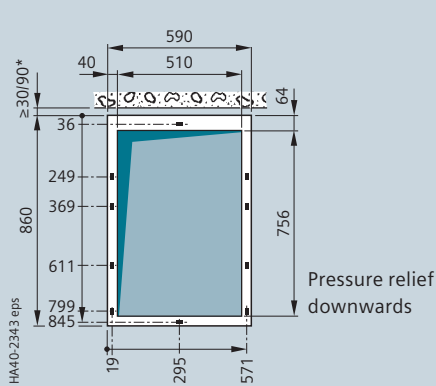

Billing metering panel

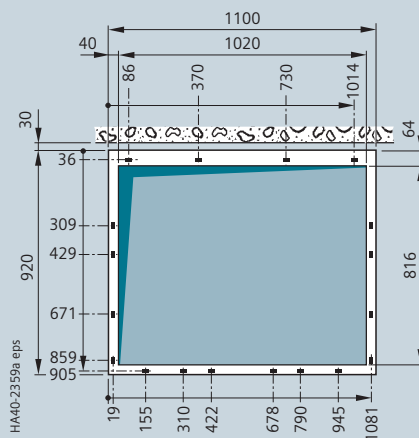
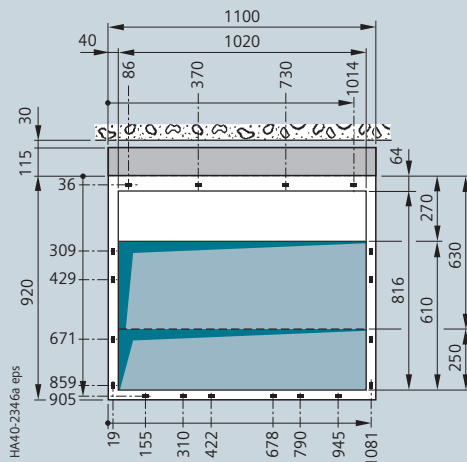

*) For switchgear with billing metering panels, all panel types except the billing metering panel have a wall distance of 90 mm.

RRT and KRT block

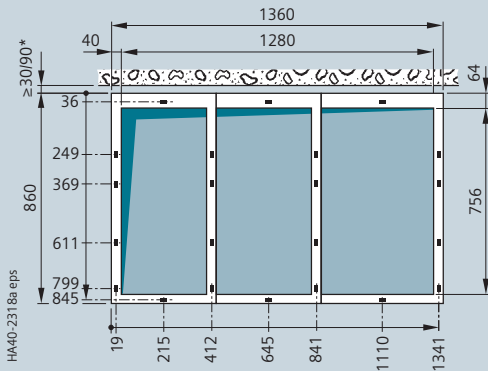

Pressure relief downwards

RRL and KRL block

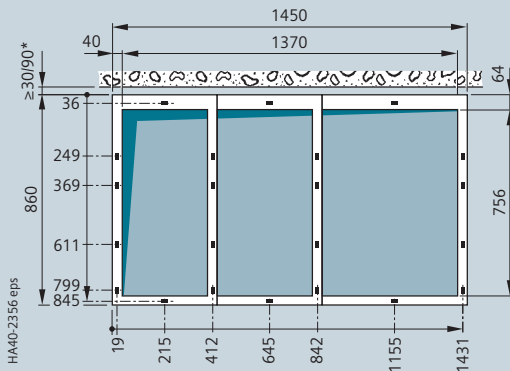

Pressure relief downwards

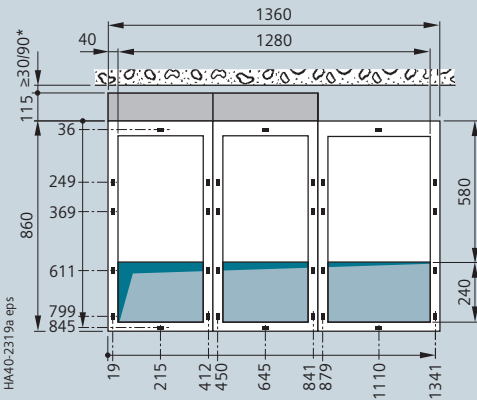

Pressure relief with duct and optional absorber

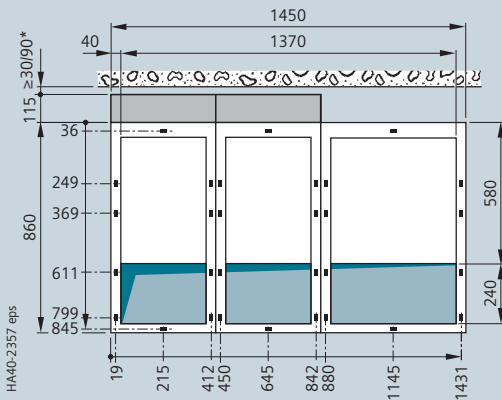

Pressure relief with duct and optional absorber

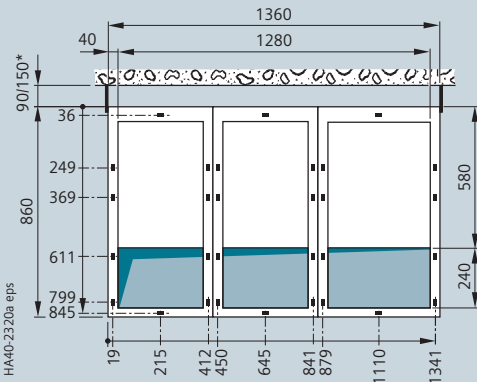

Pressure relief to the rear/upwards

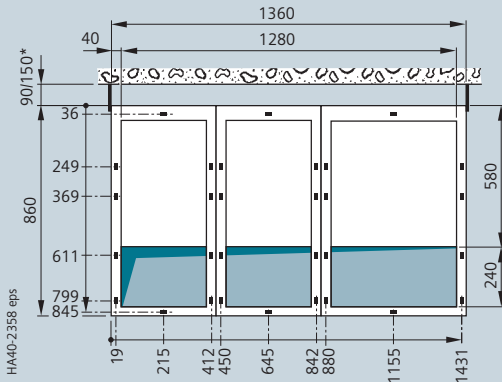

Pressure relief to the rear/upwards

*) For switchgear with billing metering panels, all panel types except the billing metering panel have a wall distance of 90 mm.

Dimensions

Floor openings and fixing points

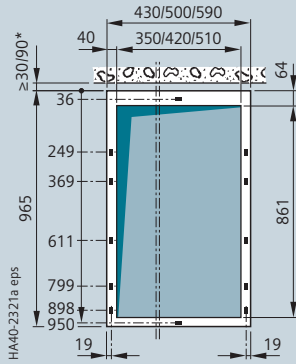

Pressure relief downwards with 105 mm deeper cable compartment cover

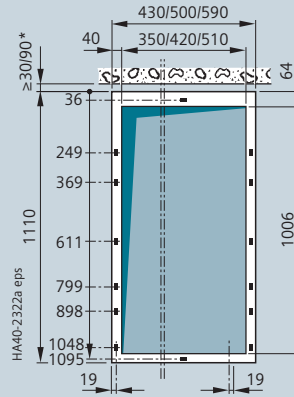

Pressure relief downwards with 250 mm deeper cable compartment cover

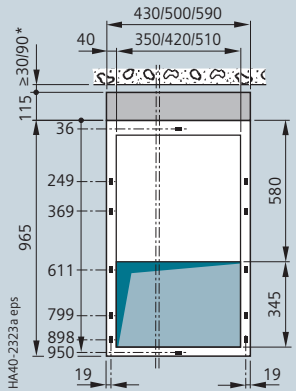

Pressure relief with duct and optional absorber, and with 105 mm deeper cable compartment cover

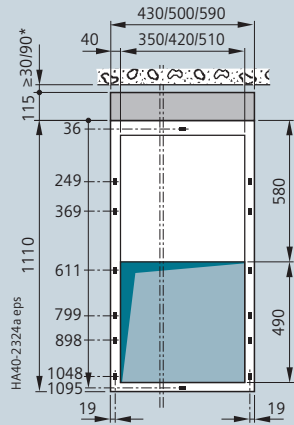

Pressure relief with duct and optional absorber, and with 250 mm deeper cable compartment cover

*) For switchgear with billing metering panels, all panel types except the billing metering panel have a wall distance of 90 mm.

Packing types (examples)

For size and weight of the transport units, see the following tables.

Means of transport	Examples for packing
Rail and truck	Type: Open PE protective foil pulled over the switchgear, with wooden base
Seafreight	Type: Open (for container transport) PE protective foil pulled over the switchgear, with wooden base
	Type: Seaworthy crate (for piece goods transport) Welded PE protective foil, with closed wooden crate, with desiccant bag
Airfreight	Type: Open PE protective foil pulled over the switchgear, with wooden base and lattice or cardboard cover

Transport

8DJH 36 switchgear is completely delivered in transport units. Please observe the following:

- Transport facilities on site
- Transport dimensions and weights
- Size of door openings in building
- Switchgear with low-voltage compartment: Please observe other transport dimensions and weights.

Transport dimensions

for Europe and overseas

Max. width of switchgear unit	Transport dimensions				
	Truck / rail / container			Seaworthy crate / airfreight	
TE	Width B	Height	Depth T	Height	Depth T
mm	m	m	m	m	m
860	1.10	A + 0.20	1.10 / 1.40 *)	A + 0.4	1.15 / 1.45 *)
1200	1.40			min. 2.00	
1600	1.80				
1910	2.05				

A = Switchgear height with or without low-voltage compartment

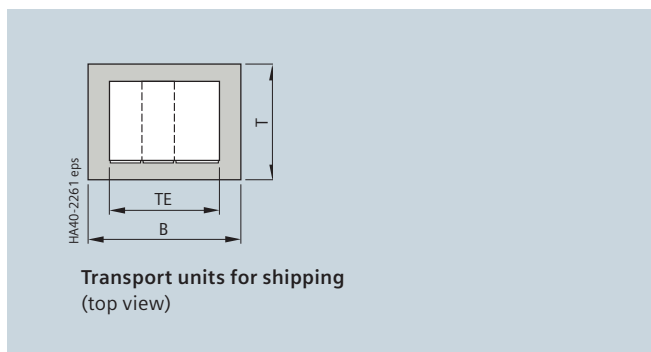

*) For switchgear with deep cable compartment cover, as well as for switchgear with pressure relief duct and pressure relief to the rear/ upwards

Types of transport (examples)

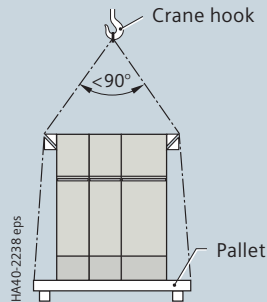

Crane transport with pallet

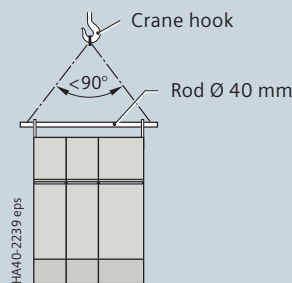

Crane transport with rod

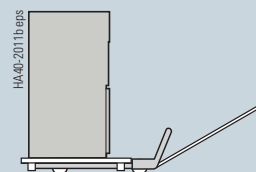

Transport with lifting truck with or without pallet

Rod Ø 40 mm (observe switchgear weight)

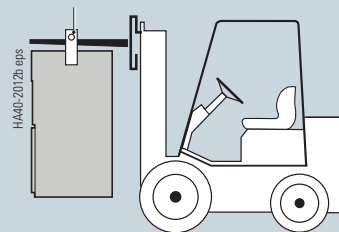

Transport with fork-lift truck, suspended

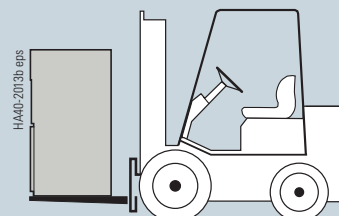

Transport with fork-lift truck, standing

Installation

Shipping data, transport

Transport weights

The transport weight results from the switchgear weight per transport unit and the packing weight. The packing weight results from the transport dimensions and the type of transport.

Packing weights

Max. width of switchgear unit	Packing weight Truck/rail/container		Packing weight Seaworthy crate / airfreight	
	1100 mm	1400 * mm	1100 mm	1400 * mm
Depth	approx. kg		approx. kg	
mm				
860	30	40	90	120
1200	40	50	120	160
1600	50	65	150	200
1910	60	80	180	235

Switchgear weights

The weight of the switchgear unit results from the sum of the weights per functional unit. Depending on the design and the degree to which it is equipped (e.g. current transformers, motor operating mechanism, low-voltage compartment), different values will result. The table shows typical values.

Panel type	Width	Gross weight	LV compartment
		1600 mm	600 mm
		approx. kg	approx. kg
R	430	180	50
K	430	180	50
T	500	300	60
L without voltage transformer 4MU1	590	400	70
L with voltage transformer 4MU1 on the busbar or at the cable connection	590	550	70
L with voltage transformer 4MU1 on the busbar and at the cable connection	590	700	70
M (BC/BB/CB)	1100	740	80
M (CC)	1100	680	80

Panel block	Width	Gross weight
	1600 mm	
	mm	approx. kg
RRT	1360	650
KRT	1360	650
RTR	1360	650
RRL	1450	750
KRL	1450	750
RLR	1450	750

* For switchgear with deep cable compartment cover, as well as for switchgear with pressure relief duct and pressure relief to the rear/upwards

Additional weights for pressure absorber

For switchgear blocks with IAC A FL/FLR up to 20 kA/1 s
Basic switchgear height 1600 mm

Additional element	Weight/kg
Cooler	30
Duct	60
Floor cover per panel	approx. 5
<i>Example</i> RRT with IAC A FL/FLR	105

Additional weights for outdoor enclosure

Width mm	1040			1470			2060		
	1040	1875	2275	1700	1875	2275	1700	1875	2275
Height mm									
Weight approx. kg	160	170	185	195	195	225	225	235	300

Type of service location

8DJH 36 switchgear can be used as indoor installation according to IEC 61936 (Power Installations exceeding AC 1 kV) and VDE 0101.

- Outside lockable electrical service locations at places which are not accessible to the public. Enclosures of switchgear can only be removed with tools.
- Inside lockable electrical service locations. A lockable electrical service location is a place outdoors or indoors that is reserved exclusively for housing electrical equipment and which is kept under lock and key. Access is restricted to authorized personnel and persons who have been properly instructed in electrical engineering. Untrained or unskilled persons may only enter under the supervision of authorized personnel or properly instructed persons.

Terms and definitions

“Make-proof earthing switches” are earthing switches with short-circuit making capacity according to IEC 62271-102 and VDE 0671-102/EN 62271-102.

Dielectric strength

- The dielectric strength is verified by testing the switchgear with rated values of short-duration power-frequency withstand voltage and lightning impulse withstand voltage according to IEC 62271-1/VDE 0671-1 (see table “Dielectric strength”).
- The rated values are referred to sea level and to normal atmospheric conditions (1013 hPa, 20 °C, 11g/m³ humidity according to IEC 60071 and VDE 0111)
- The dielectric strength decreases with increasing altitude. For site altitudes above 1000 m (above sea level) the standards do not provide any guidelines for the insulation rating, but leave this to the scope of special agreements.

The gas insulation at a relative gas pressure of 50 kPa permits switchgear installation at any desired altitude above sea level without the dielectric strength being adversely affected. This also applies to the cable connection when plug-in sealing ends are used.

A decrease (reduction) of the dielectric strength with increasing site altitude must only be considered for panels with HV HRC fuses as well as for air-insulated metering panels and a site altitude of 1000 m (above sea level).

Standards

8DJH 36 switchgear complies with the relevant standards and specifications applicable at the time of type tests. In accordance with the harmonization agreement reached by the countries of the European Union, their national specifications conform to the IEC standard.

Table – Dielectric strength

Rated voltage (r.m.s. value)	kV	36
Rated short-duration power-frequency withstand voltage (r.m.s. value)		
– Between phases and to earth	kV	70
– Across isolating distances	kV	80
Rated lightning impulse withstand voltage (peak value)		
– Between phases and to earth	kV	170
– Across isolating distances	kV	195

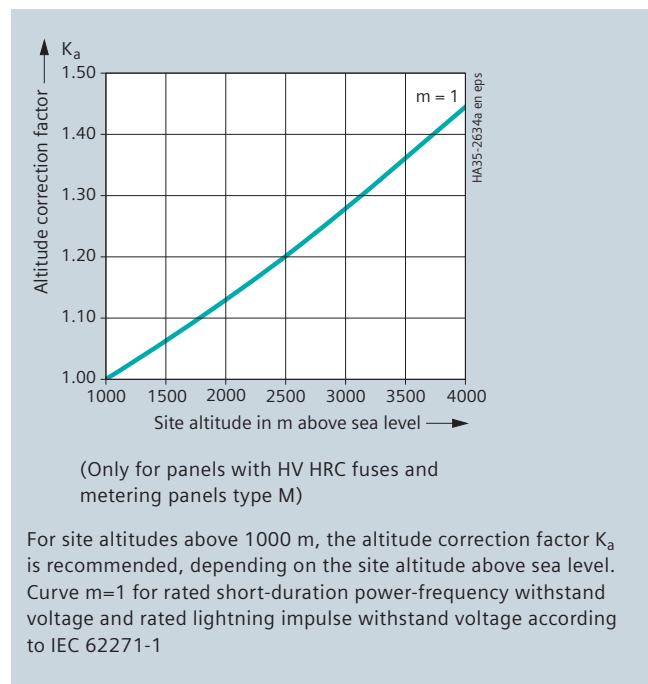
Altitude correction factor K_a for panels with HV HRC fuses or for metering panels type M**Overview of standards (June 2017)**

		IEC standard	VDE standard	EN standard
Switchgear	8DJH 36	IEC 62271-1	VDE 0671-1	EN 62271-1
		IEC 62271-200	VDE 0671-200	EN 62271-200
		IEC 62271-304	–	eLC/TS 62271-304
Devices	Circuit-breakers	IEC 62271-100	VDE 0671-100	EN 62271-100
	Disconnectors and earthing switches	IEC 62271-102	VDE 0671-102	EN 62271-102
	Switch-disconnectors	IEC 60271-103	VDE 0671-103	EN 60271-103
	Switch-disconnector/ fuse combination	IEC 62271-105	VDE 0671-105	EN 62271-105
	HV HRC fuses	IEC 60282-1	VDE 0670-4	IEC 60282-1
	Voltage detecting systems	IEC 61243-5	VDE 0682-415	EN 61243-5
Degree of protection	IP code	IEC 60529	VDE 0470-1	EN 60529
	IK code	IEC 62262	VDE 0470-100	EN 50102
Insulation	–	IEC 60071	VDE 0111	EN 60071
Instrument transformers	Current transformers	IEC 61869-2	VDE 0414-9-2	EN 61869-2
	Voltage transformers	IEC 61869-3	VDE 0414-9-3	EN 61869-3
Installation, erection	–	IEC 61936-1	VDE 0101	–
Insulating gas SF ₆	Specification for new SF ₆	IEC 60376	VDE 0373-1	EN 60376

Standards

Standards, specifications, guidelines

Current carrying capacity

- According to IEC 62271-200 or IEC 62271-1, VDE 0671-200 or VDE 0671-1, the rated normal current refers to the following ambient air temperatures:
 - Maximum of 24-hour mean + 35 °C
 - Maximum + 40 °C
- The current carrying capacity of the panels and busbars depends on the ambient air temperature outside the enclosure.

Appearance of internal faults

In gas-insulated switchgear 8DJH 36, faults leading to internal arcing are widely excluded by the construction due to the following measures:

- Use of gas-filled switchgear compartments
- Use of suitable switching devices such as three-position switches with make-proof earthing switch
- Logical mechanical interlocks
- Use of metal-enclosed voltage transformers, and current transformers as ring-core transformers (exception: air-insulated billing metering panel)
- There are no effects due to external influences, such as
 - Pollution layers
 - Humidity
 - Small animals and foreign objects
- Maloperation is practically excluded due to logical arrangement of operating elements
- Short-circuit-proof feeder earthing by means of the three-position switch-disconnector.

In the event of an arc fault at the cable connection or in the unlikely case inside the switchgear vessel, pressure relief is effected downwards into the cable basement.

For the use in substation buildings without internal arcing test, such as “old substations”, the switchgear can be designed with a modified pressure relief system with absorbers (option).

As a “special cooling system”, this maintenance-free pressure absorber system reduces the pressure-dependent and thermal effects of internal arcing in switchgear vessels and cable compartments, and thus protects people and buildings.

The closed system is suitable for both wall-standing and free-standing arrangement.

Internal arcing test (design option)

- Protection of operating personnel by means of tests for verifying the internal arc classification
- Internal arcing tests must be performed in accordance with IEC/EN 62271-200/VDE 0671-200 for IAC (internal arc classification)
- Definition of criteria:
 - Criterion 1
Correctly secured doors and covers do not open, limited deformations are accepted
 - Criterion 2
No fragmentation of the enclosure, no projection of small parts above 60 g
 - Criterion 3
No holes in accessible sides up to a height of 2 m
 - Criterion 4
No ignition of indicators due to hot gases
 - Criterion 5
The enclosure remains connected to its earthing point.

Optionally, 8DJH 36 switchgear can be designed with internal arc classification.

Color of the panel front

Siemens standard (SN) 47 030 G1, color no. 700/light basic (similar to RAL 7047/gray).

Climate and environmental influences

All parts of the primary circuit of the 8DJH 36 switchgear which are subjected to high voltage are completely enclosed and insensitive to climatic influences.

- All medium-voltage devices (except for HV HRC fuses) are installed in a gas-tight, welded stainless-steel switchgear vessel which is filled with SF₆ gas
- Live parts outside the switchgear vessel are provided with single-pole enclosure
- At no point can creepage currents flow from high-voltage potentials to earth
- Operating mechanism parts which are functionally important are made of corrosion-resistant materials
- Bearings in the operating mechanism are designed as dry-type bearings and do not require lubrication.

The 8DJH 36 switchgear is suitable for application in indoor installations under normal operating conditions as defined in the standard IEC 62271-1.

Furthermore, the high-voltage part of 8DJH 36 switchgear can be used in environmental conditions of the climatic category 3C2 according to the standard IEC 60721-3-3.

8DJH 36 has been subjected to a climatic test according to IEC 60932, Level 2, and is suitable for operating conditions according to “Design Class 2”.

These tests also meet the requirements of IEC 62271-304 for “Design Class 2”.

**Protection against solid foreign objects,
electric shock and water**

8DJH 36 switchgear fulfills according to the standards

IEC 62271-1	VDE 0671-1, EN 62271-1
IEC 62271-200	VDE 0671-200, EN 62271-200
IEC 60529	VDE 0470-1, EN 60529
IEC 62262	VDE 0470-100, EN 50102

the following degrees of protection:

Degree of protection IP	Type of protection
IP 65	for parts of the primary circuit under high voltage
IP2X	for switchgear enclosure
IP3X	for switchgear enclosure (optional)

Degree of protection IK	Type of protection
IK 07	for switchgear enclosure

Recycling

The switchgear can be recycled in ecological manner in compliance with existing legislation. Auxiliary devices such as short-circuit indicators have to be recycled as electronic scrap. Batteries have to be recycled professionally. Insulating gas SF₆ has to be evacuated professionally as a reusable material and recycled (SF₆ must not be released into the environment).

Published by
Siemens AG 2017

Energy Management
Medium Voltage & Systems
Mozartstraße 31 C
91052 Erlangen, Germany

For further information please contact
our Customer Support Center
Phone: +49 180 524 70 00
Fax: +49 180 524 24 71
E-mail: support.energy@siemens.com
siemens.com/medium-voltage-switchgear
siemens.com/8DJH36

Article No. EMM5-K1440-A311-A3-7600
Printed in Germany
Dispo 40401
PU 002926 KG 08.17 1.0

Subject to changes and errors. The information
given in this document only contains general
descriptions and/or performance features which
may not always specifically reflect those described,
or which may undergo modification in the course
of further development of the products.
The requested performance features are binding
only when they are expressly agreed upon in the
concluded contract.

2017



AUXILIARY LV TRANSFORMER DATA SHEET

Code	-	-
Ambient temperature (min)	°C	-20
Ambient temperature (max)	°C	50
Installation altitude (max)	m a.s.l.	1,000

TRANSFORMER FOR OUTDOOR INSTALLATION

Electrical Features		
Type	-	Three phase dry type transformer
Installation	-	Outdoor (with IP54 protection enclosure)
Number of phases	-	3
Rated power	kVA	30
Rated frequency	Hz	50
Cooling system	-	AN
Primary voltage	V	$615 \pm 2 \times 2.5\%$
Secondary voltage	V	400
Vector group	-	Dyn11
Insulation levels - primary side	kV	3.6 / 10
Insulation levels - secondary side	kV	1.1 / 3
Winding material - primary side	-	Aluminum
Winding material - secondary side	-	Aluminum
Reference temperature	°C	120
No-load losses	W	≤ 230
Load losses (at ref. temperature)	W	≤ 670
Short-circuit impedance	%	3
No load current	%	< 5
Type of service	-	Continuous
Thermal insulation type	-	H
Overtemperature type (referred to 40°C):	-	B
Electrostatic shield	-	1
Standard	-	IEC 60076-11, IEC 61558-2-2
Sound pressure level	dB(A)	$< 60 @ 1 \text{ m}$

Mechanical Features		
Connection system	-	IP20 terminals
Protection rating	-	IP54
Corrosion protection	-	C4-H
Dimensions (W x D x H)	mm	TBD (*)
Weight	Kg	TBD (*)

(*) Ingeteam reserves the right to change mechanical data maintaining unmodified the electrical characteristics.

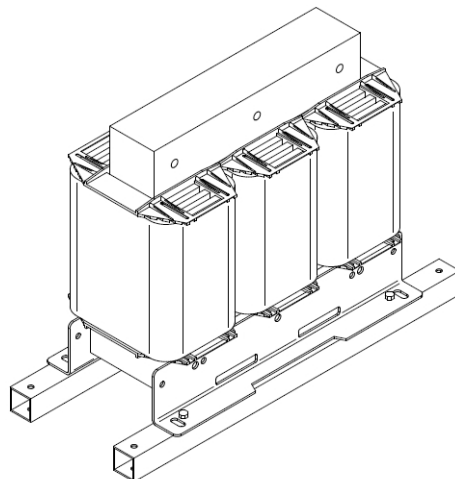

OIL INSULATED TRANSFORMER DATA SHEET

Ambient temperature (min)	°C	-20	Code: -
Ambient temperature (max)	°C	50	Corrosive environment classification: C4-H
Max. installation altitude	m a.s.l.	1,000	Losses according to EU 548/2014 Tier 2 / EU 2019/1783

TRANSFORMER FOR OUTDOOR INSTALLATION

Electrical Features			Accessories Included
Type	-	Hermetic	Integrated safety detector protection relay for electrical transformers (DGPT2 or equivalent). Detection: <ul style="list-style-type: none"> • Gas discharge or drop of the dielectric level (1 contact) • Internal pressure (1 contact) • Dielectric temperature (2 contacts) Reading: <ul style="list-style-type: none"> • Dielectric temperature • Dielectric level or gas volume PT100 sensor for oil temperature N. 3 H.V. terminals plug-in bushings Elastimold type N. 3 L.V. terminals, IP00 bushings N. 2 Earth terminals in stainless steel N. 1 Electrostatic shield in between primary & secondary windings IP55 junction box for auxiliary connections Pressure release valve Oil filling device with breather valve Oil draining device First oil filling Lifting lugs Towing hooks Registration plate with data Documentation: <ul style="list-style-type: none"> • User and installation guide in English language • Bulletin related to the test applied • Oil Certificate • Certificate of conformity
Insulating fluid	-	Mineral Oil	
Power	kVA	1,600 @ 30°C	
Power	kVA	1,520 @ 40°C	
Power	kVA	1,440 @ 50°C	
Primary voltage	kV	30	
Secondary voltage	kV	0.615	
Off load tap changer	%	± 2 × 2.5	
Primary phase current	A	30.8	
Secondary phase current	A	1,502	
Vector group	-	Dy11	
Frequency	Hz	50	
Cooling system	-	ONAN	
No load current	%	0.5	
Insulation levels - primary side	kV	36 / 70 / 170	
Insulation levels - secondary side	kV	3.6 / 10	
Winding material - primary side	-	Aluminum	
Winding material - secondary side	-	Aluminum	
Sound pressure level, LpA	dB(A)	TBD	
No Load losses	W	1,290	
Load losses (75°C)	W	12,700 (*)	
Impedance voltage, V _{sc}	%	7 (*)	
Series resistance R (primary side)	Ω	TBD	
Series reactance X (primary side)	Ω	TBD	
Voltage drop	cos φ = 0.8	100%	TBD
Efficiency	cos φ = 0.8	50%	TBD
Efficiency	cos φ = 0.8	75%	TBD
Efficiency	cos φ = 0.8	100%	TBD
Max temperature rise - oil	K	60 (**)	
Max temperature rise - windings	K	65 (**)	
Winding hot spot	K	78 (**)	
Mechanical Features			
Hermetic / Expansion vessel	-	Hermetic	
Overall protection rating ⁽¹⁾	-	IP55	⁽¹⁾ Excluding MV/LV terminals
Colour	-	RAL 7035	
Length	mm	TBD (***)	
Height	mm	TBD (***)	
Depth	mm	TBD (***)	
Oil weight	kg	TBD (***)	
Unit total weight	kg	TBD (***)	

Transformers in this specification are engineered, manufactured and tested according to IEC 60076 Standard.

The transformers are suitable for outdoor installations under direct solar radiation.

Ingeteam qualified suppliers: ABB, Siemens, SEA, GBE, CELME, Westrafo, Trafo Elettro, Newton Trasformatori, Ormazabal, Alkargo Transformers, IMEFY SL, Telawne Power Equipments, ELTAS, BEST Transformers, Sanil Electric Co., GE, SGB-SMIT Group.

(*) Referred to 1,600 kVA at 30°C ambient temperature (Peak Efficiency Index ≥ 99.494%).

(**) Referred to 40°C ambient temperature.

(***) Ingeteam reserves the right to change mechanical data maintaining unmodified the electrical characteristics.

OIL INSULATED TRANSFORMER DATA SHEET

Ambient temperature (min)	°C	-20	Code: -
Ambient temperature (max)	°C	50	Corrosive environment classification: C4-H
Max. installation altitude	m a.s.l.	1,000	Losses according to EU 548/2014 Tier 2 / EU 2019/1783

TRANSFORMER FOR OUTDOOR INSTALLATION

Electrical Features			Accessories Included
Type	-	Hermetic	Integrated safety detector protection relay for electrical transformers (DGPT2 or equivalent). Detection: <ul style="list-style-type: none"> • Gas discharge or drop of the dielectric level (1 contact) • Internal pressure (1 contact) • Dielectric temperature (2 contacts) Reading: <ul style="list-style-type: none"> • Dielectric temperature • Dielectric level or gas volume PT100 sensor for oil temperature N. 3 H.V. terminals plug-in bushings Elastimold type N. 3 L.V. terminals, IP00 bushings N. 2 Earth terminals in stainless steel N. 1 Electrostatic shield in between primary & secondary windings IP55 junction box for auxiliary connections Pressure release valve Oil filling device with breather valve Oil draining device First oil filling Lifting lugs Towing hooks Registration plate with data Documentation: <ul style="list-style-type: none"> • User and installation guide in English language • Bulletin related to the test applied • Oil Certificate • Certificate of conformity
Insulating fluid	-	Mineral Oil	
Power	kVA	3,200 @ 30°C	
Power	kVA	3,040 @ 40°C	
Power	kVA	2,880 @ 50°C	
Primary voltage	kV	30	
Secondary voltage	kV	0.615	
Off load tap changer	%	± 2 × 2.5	
Primary phase current	A	61.59	
Secondary phase current	A	3,004	
Vector group	-	Dy11	
Frequency	Hz	50	
Cooling system	-	ONAN	
No load current	%	0.5	
Insulation levels - primary side	kV	36 / 70 / 170	
Insulation levels - secondary side	kV	3.6 / 10	
Winding material - primary side	-	Aluminum	
Winding material - secondary side	-	Aluminum	
Sound pressure level, LpA	dB(A)	TBD	
No Load losses	W	2,410	
Load losses (75°C)	W	24.600 (*)	
Impedance voltage, V _{sc}	%	7 (**)	
Series resistance R (primary side)	Ω	TBD	
Series reactance X (primary side)	Ω	TBD	
Voltage drop	cos φ = 0.8	100%	TBD
Efficiency	cos φ = 0.8	50%	TBD
Efficiency	cos φ = 0.8	75%	TBD
Efficiency	cos φ = 0.8	100%	TBD
Max temperature rise - oil	K	60 (**)	
Max temperature rise - windings	K	65 (**)	
Winding hot spot	K	78 (**)	
Mechanical Features			
Hermetic / Expansion vessel	-	Hermetic	
Overall protection rating ⁽¹⁾	-	IP55	⁽¹⁾ Excluding MV/LV terminals
Colour	-	RAL 7035	
Length	mm	TBD (***)	
Height	mm	TBD (***)	
Depth	mm	TBD (***)	
Oil weight	kg	TBD (***)	
Unit total weight	kg	TBD (***)	

Transformers in this specification are engineered, manufactured and tested according to IEC 60076 Standard.

The transformers are suitable for outdoor installations under direct solar radiation.

Ingeteam qualified suppliers: ABB, Siemens, SEA, GBE, CELME, Westrafo, Trafo Elettro, Newton Trasformatori, Ormazabal, Alkargo Transformers, IMEFY SL, Telawne Power Equipments, ELTAS, BEST Transformers, Sanil Electric Co., GE, SGB-SMIT Group.

(*) Referred to 3,200 kVA at 30°C ambient temperature (Peak Efficiency Index ≥ 99.519%).

(**) Referred to 40°C ambient temperature.

(***) Ingeteam reserves the right to change mechanical data maintaining unmodified the electrical characteristics.

OIL INSULATED TRANSFORMER DATA SHEET

Ambient temperature (min)	°C	-20	Code: -
Ambient temperature (max)	°C	50	Corrosive environment classification: C4-H
Max. installation altitude	m a.s.l.	1,000	Losses according to EU 548/2014 Tier 2 / EU 2019/1783
TRANSFORMER FOR OUTDOOR INSTALLATION			
Electrical Features			Accessories Included
Type	-	Hermetic	Integrated safety detector protection relay for electrical transformers (DGPT2 or equivalent). Detection: <ul style="list-style-type: none"> • Gas discharge or drop of the dielectric level (1 contact) • Internal pressure (1 contact) • Dielectric temperature (2 contacts) Reading: <ul style="list-style-type: none"> • Dielectric temperature • Dielectric level or gas volume PT100 sensor for oil temperature N. 3 H.V. terminals plug-in bushings Elastimold type N. 6 L.V. terminals, IP00 bushings N. 2 Earth terminals in stainless steel N. 1 Electrostatic shield in between primary & secondary windings IP55 junction box for auxiliary connections Pressure release valve Oil filling device with breather valve Oil draining device First oil filling Lifting lugs Towing hooks Registration plate with data Documentation: <ul style="list-style-type: none"> • User and installation guide in English language • Bulletin related to the test applied • Oil Certificate • Certificate of conformity
Insulating fluid	-	Mineral Oil	
Power	kVA	4,800 @ 30°C	
Power	kVA	4,560 @ 40°C	
Power	kVA	4,320 @ 50°C	
Primary voltage	kV	30	
Secondary voltage	kV	0.615	
Off load tap changer	%	± 2 × 2.5	
Primary phase current	A	92.38	
Secondary phase current	A	4,506	
Vector group	-	Dy11	
Frequency	Hz	50	
Cooling system	-	ONAN	
No load current	%	0.5	
Insulation levels - primary side	kV	36 / 70 / 170	
Insulation levels - secondary side	kV	3.6 / 10	
Winding material - primary side	-	Aluminum	
Winding material - secondary side	-	Aluminum	
Sound pressure level, LpA	dB(A)	TBD	
No Load losses	W	3,600	
Load losses (75°C)	W	33,100 (*)	
Impedance voltage, V _{sc}	%	7 (*)	
Series resistance R (primary side)	Ω	TBD	
Series reactance X (primary side)	Ω	TBD	
Voltage drop	cos φ = 0.8	100%	TBD
Efficiency	cos φ = 0.8	50%	TBD
Efficiency	cos φ = 0.8	75%	TBD
Efficiency	cos φ = 0.8	100%	TBD
Max temperature rise - oil	K	60 (**)	
Max temperature rise - windings	K	65 (**)	
Winding hot spot	K	78 (**)	
Mechanical Features			
Hermetic / Expansion vessel	-	Hermetic	
Overall protection rating ⁽¹⁾	-	IP55	⁽¹⁾ Excluding MV/LV terminals
Colour	-	RAL 7035	
Length	mm	TBD (***)	
Height	mm	TBD (***)	
Depth	mm	TBD (***)	
Oil weight	kg	TBD (***)	
Unit total weight	kg	TBD (***)	

Transformers in this specification are engineered, manufactured and tested according to IEC 60076 Standard.
 The transformers are suitable for outdoor installations under direct solar radiation.
 Ingeteam qualified suppliers: ABB, Siemens, SEA, GBE, CELME, Westrafo, Trafo Elettro, Newton Trasformatori, Ormazabal, Alkargo Transformers, IMEFY SL, Telawne Power Equipments, ELTAS, BEST Transformers, Sanil Electric Co., GE, SGB-SMIT Group.

(*) Referred to 4,800 kVA at 30°C ambient temperature (Peak Efficiency Index ≥ 99.545%).
 (**) Referred to 40°C ambient temperature.
 (***) Ingeteam reserves the right to change mechanical data maintaining unmodified the electrical characteristics.

OIL INSULATED TRANSFORMER DATA SHEET

Ambient temperature (min)	°C	-20	Code: -
Ambient temperature (max)	°C	50	Corrosive environment classification: C4-H
Max. installation altitude	m a.s.l.	1,000	Losses according to EU 548/2014 Tier 2 / EU 2019/1783
TRANSFORMER FOR OUTDOOR INSTALLATION			
Electrical Features			Accessories Included
Type	-	Hermetic	Integrated safety detector protection relay for electrical transformers (DGPT2 or equivalent). Detection: <ul style="list-style-type: none"> • Gas discharge or drop of the dielectric level (1 contact) • Internal pressure (1 contact) • Dielectric temperature (2 contacts) Reading: <ul style="list-style-type: none"> • Dielectric temperature • Dielectric level or gas volume PT100 sensor for oil temperature N. 3 H.V. terminals plug-in bushings Elastimold type N. 6 L.V. terminals, IP00 bushings N. 2 Earth terminals in stainless steel N. 2 Electrostatic shields in between primary & secondary windings IP55 junction box for auxiliary connections Pressure release valve Oil filling device with breather valve Oil draining device First oil filling Lifting lugs Towing hooks Registration plate with data Documentation: User and installation guide in English language Bulletin related to the test applied Oil Certificate Certificate of conformity
Insulating fluid	-	Mineral Oil	
Power	kVA	6,400 @ 35°C	
Power	kVA	6,080 @ 40°C	
Power	kVA	5,760 @ 45°C	
Primary voltage	kV	30	
Secondary voltage	kV	2 x 0.615	
Off load tap changer	%	± 2 x 2.5	
Primary phase current	A	123.2	
Secondary phase current	A	2 x 3,004	
Vector group	-	Dd0y11	
Frequency	Hz	50	
Cooling system	-	ONAN	
No load current	%	0.5	
Insulation levels - primary side	kV	36 / 70 / 170	
Insulation levels - secondary side	kV	3.6 / 10	
Winding material - primary side	-	Aluminum	
Winding material - secondary side	-	Aluminum	
Sound pressure level, LpA	dB(A)	TBD	
No Load losses	W	4,800	
Load losses (75°C)	W	39,100 (*)	
Impedance voltage, HV/LV ₁ -LV ₂	%	8 (*)	
Impedance voltage, HV/LV ₁	%	7 (*)	
Impedance voltage, HV/LV ₂	%	7 (*)	
Series resistance R (primary side)	Ω	TBD	
Series reactance X (primary side)	Ω	TBD	
Voltage drop	cos φ = 0.8	100%	TBD
Efficiency	cos φ = 0.8	50%	TBD
Efficiency	cos φ = 0.8	75%	TBD
Efficiency	cos φ = 0.8	100%	TBD
Max temperature rise - oil	K	60 (**)	
Max temperature rise - windings	K	65 (**)	
Winding hot spot	K	78 (**)	
Mechanical Features			
Hermetic / Expansion vessel	-	Hermetic	
Overall protection rating ⁽¹⁾	-	IP55	⁽¹⁾ Excluding MV/LV terminals
Length	mm	TBD (***)	
Height	mm	TBD (***)	
Depth	mm	TBD (***)	
Oil weight	kg	TBD (***)	
Unit total weight	kg	TBD (***)	

Transformers in this specification are engineered, manufactured and tested according to IEC 60076 Standard.

The transformers are suitable for outdoor installations under direct solar radiation.

Ingeteam qualified suppliers: ABB, Siemens, SEA, GBE, CELME, Westrafo, Trafo Elettro, Newton Trasformatori, Ormazabal, Alkargo Transformers, IMEFY SL, Telawne Power Equipments, ELTAS, BEST Transformers, Sanil Electric Co., GE, SGB-SMIT Group.

(*) Referred to 6,400 kVA at 30°C ambient temperature (Peak Efficiency Index ≥ 99.572%).

(**) Referred to 40°C ambient temperature.

(***) Ingeteam reserves the right to change mechanical data maintaining unmodified the electrical characteristics.

PV PLANT CONTROL SYSTEM

The INGECON® SUN Plant Controller helps the grid operator to manage the PV plant performance and to guarantee the quality and stability of the electricity supply.

Maximum PV plant control

An advanced algorithm combined with a fast and efficient communications system, with response times of less than one second, allows for a precise control of the active and reactive power delivered by the plant to the grid.

The INGECON® SUN Plant Controller controls the PV inverters, ensuring compliance with the grid operator's requirements at the PV plant connection point. It is also possible to manage energy storage systems and other devices such as diesel generators, through the use of INGECON® SUN STORAGE Power inverters.

This is a flexible system that can easily be adapted to the needs and configurations of each particular plant, whilst complying with the country-specific standards and regulations.

Continuous communication with all the devices

The Power Plant Controller dynamically receives the grid operator's setpoints. For this purpose, a number of communication protocols are incorporated such as Modbus TCP / RTU, DNP3, IEC 60870-5-101, IEC 60870-5-104 and OPC UA. Likewise, it is also possible to add digital and analogue I/O modules in order to extend the communication capabilities with third-party devices.

Furthermore, the INGECON® SUN Plant Controller permits communication with the plant SCADA to transmit the connection point data. It is also possible a manual control for temporary maintenance or engineering operations.



Plant Controller

Description of the complete system

A PV plant with a plant controller typically consists of:

- INGECON® SUN Plant Controller, comprising two basic systems: metering and control. It can additionally incorporate a communication channel with the grid operator in order to receive the operating setpoints.
- INGECON® SUN PV inverters connected to the PV array.
- INGECON® SUN STORAGE battery inverters connected to the energy storage system.
- SCADA, plant monitoring system.

- Communications network. Connecting the INGECON® SUN Plant Controller with the different inverters, transmitting the operating setpoints and monitoring the status of the equipment.

Operating mode

For the control, the INGECON® SUN Plant Controller takes the following data:

- Active power, reactive power, voltage and frequency at the point of connection, provided by the integrated metering unit.
- Grid operator requirements. To establish references for parameters such as voltage at the point of connection, ac-

tive and reactive power, power ramps, active power reserve, etc. These requirements can be predetermined either by the grid operator or by the plant operator or dynamically modified through an external setpoint.

- Instantaneous values of the various elements inside the plant: inverters, batteries, weather stations, reactive power compensation systems.
- With all these data, the controller can determine the optimum operating setpoints for each inverter integrated into the system and transmit the setpoints through the communications network.

Schema

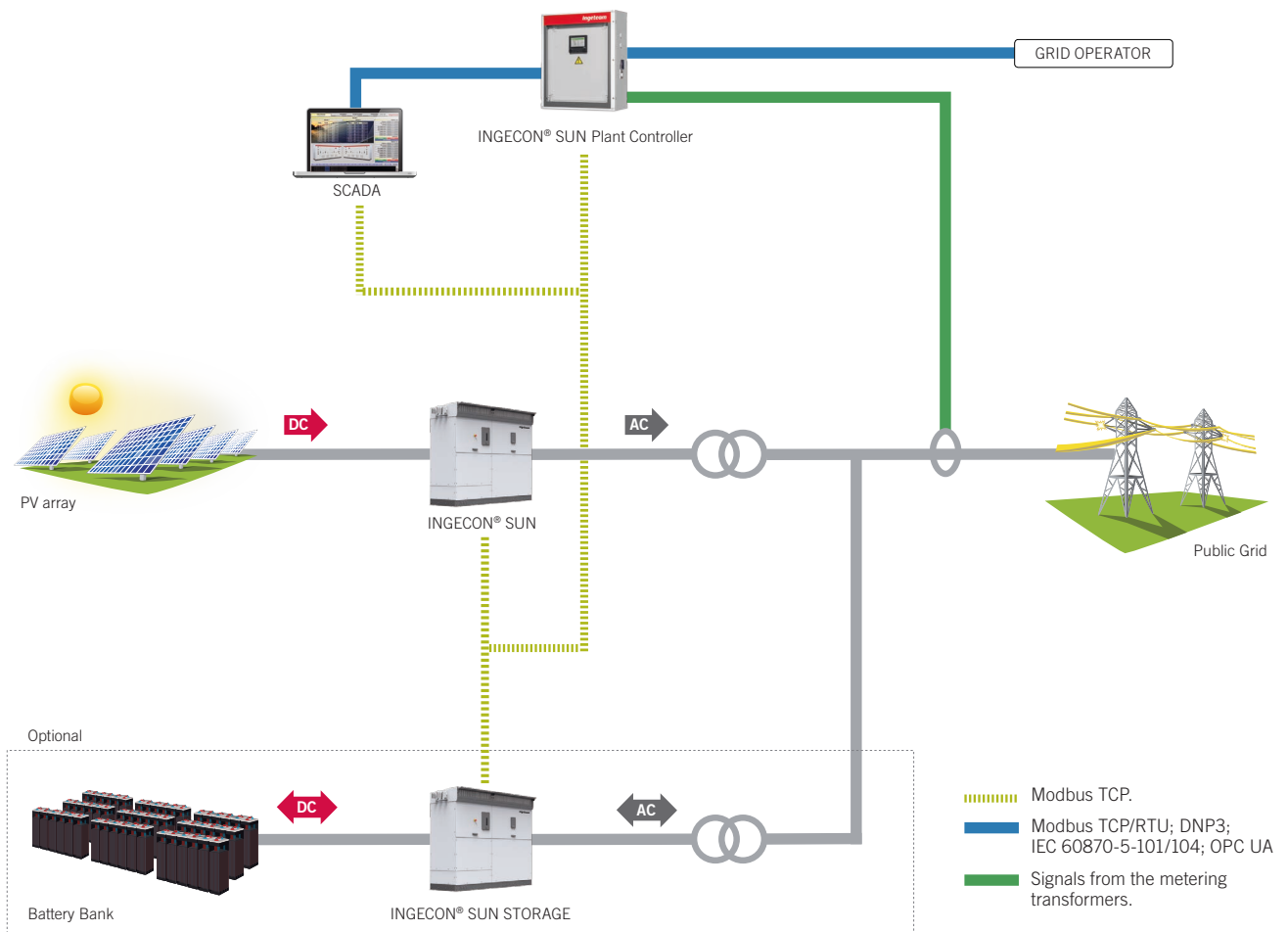

System Features

Production Control

Some of the active power control functions that can be implemented in the INGECON® SUN Plant Controller are:

- **Active Power Curtailment.** It controls the PV plant's output power, limiting it to a desired value.
- **Ramp Rate Control.** It controls the power generated by the inverters, ensuring that the variation in the plant power output conforms to the established setpoint. So as to control any power variation, it is necessary to add an energy storage system.
- **Fast Frequency Regulation.** The system adjusts the power production depending on the frequency variations.
- **Energy Time Shifting.** This control mode enables an advanced power generation planning, making the power plant's production profile unmatch the consumption profile.
- **P Open Loop.** This operating mode allows for controlling the active power generated at the inverter's terminals, and thus any inverter working point.
- **Hybrid Self-Consumption.** An energy storage system allows for a more optimised use of solar energy, utilising the energy stored to compensate the surplus or shortfalls of solar power, while controlling the active power injected to the grid.

- **Uninterrupted Power Supply.** When a grid-tied system becomes an isolated one as a consequence of a distant interruptor opening, the power plant can create an AC grid in order to feed the loads.
- **Stand-Alone Generation.** In this mode, one of the inverters will create an AC grid by generating an AC voltage and frequency for the loads and the other inverters.
- **Solar Power Reserve.** The INGECON® SUN Plant Controller incorporates an innovative control strategy to guarantee an active power reserve with no need to include storage systems (depending on the availability of the PV resource), although it is also compatible with the addition of an ESS.

Grid Support

Some of the reactive power control functions that can be implemented in the INGECON® SUN Plant Controller are:

- **On Demand Q.** The system developed by Ingeteam allows to control the reactive power output, adjusting it to a given reference.
- **Power Factor Control.** Regulation of the power factor at the point of connection.
- **Black Start Capability.** The system can restore the electric supply during a blackout by creating an AC network to power the loads.

ing a blackout by creating an AC network to power the loads.

- **Q Open Loop.** This operating mode allows for controlling the reactive power generated at the inverter's terminals, and thus any inverter working point.
- **Dynamic Reactive Compensation.** With this mode, the reactive power at the point of connection can be compensated up to any desired value, 24 hours a day.
- **Automatic Voltage Regulation.** The INGECON® SUN Plant Controller makes it possible to regulate the plant voltage at the point of connection through a control system applied to the voltage closed loop.
- **Voltage Droop Control.** According to an established Droop gain, the system selects the necessary reactive power at the point of connection, depending on the existing voltage difference.
- **Power Oscillations Damping.** In those places where the grid is divided in different interconnected zones, the power plant can suffer from low-frequency active power oscillations. The Plant Controller allows to implement a control strategy to minimise these oscillations in both stationary and transitory regimes.

Two models available:



Standard version



Premium version

INCLUDED ITEMS

- PLC.
- Power analyzer.
- Communications switch.
- Power supply.
- Protections.
- O&M socket.

OPTIONAL INPUTS / OUTPUTS

- Analogue inputs V/I.
- Analogue outputs V/I.
- Digital inputs.
- Digital outputs @24 Vdc or potential-free digital outputs.

	Standard version	Premium version
Power Analyzer		
Energy metering accuracy	0.5 s / 0.2 s / 0.2 s	
Voltage metering accuracy	0.2% / 0.1% / 0.1%	
Current metering accuracy	0.2% / 0.2% / 0.1%	
Frequency metering accuracy	10 mHz ⁽¹⁾	
Power metering accuracy	0.5% / 0.2% / 0.2%	
THD metering accuracy	Class 0.5 s	
Voltage and current harmonics metering	1..40 / 1..63 / 1..63	
Input voltage metering range	0..480 V @50 Hz / 0..347 V @60 Hz	
Input current metering range	0..5 A	
Other measurements	Unbalances / Rotation sequence / Positive, negative and homopolar sequences	
Production quality registration (PQ)	Optional	
Redundancy	Optional	
Power Supply		
Voltage supply	85 Vac..264 Vac, 50 Hz..60 Hz	
Typical consumption ⁽²⁾	75 W	225 W
Maximum consumption ⁽²⁾	90 W	270 W
UPS capacity ⁽³⁾	15 Wh / 288 Wh	
Redundancy	Optional	
Communication		
Standard protocols	Modbus / TCP (client and server), FTP (client and server), NTP (client and server)	
Compatible protocols	Modbus / RTU (Master and slave), 101 (Slave), 104 (Slave), DNP3 (Slave), OPC UA (Server)	
Outer connectivity	10 / 100BaseT(X), 100BaseFX with patch panels	
Managed communication	Optional	Yes, with SNMP v1/2/3, VLAN, DHCP, Flow control, NTP, MAC filter
Redundancy	Optional	
Compatibility		
Inverters	IS 3Play, IS Power, ISS Power	
Utilities	Main industry protocols	
Batteries	Main manufacturers	
SCADA	Main industry protocols	
Reactive power compensation systems	Modbus or hard-wired interface	
On load tap changer	Modbus or hard-wired interface	
Weather Stations	Modbus interface	
O&M Functions		
Datalogger	4 GB Compact Flash memory	
Equipment start up / stop	General start up or stop of the inverters, BESS and capacitor banks	
Power plant surveillance	Monitoring of the status of every single element inside the plant	
Others	Web server	
CPU		
Typical processing time	< 10 ms	
Clock	Internal RTC synchronizable through NTP	
Surveillance system	Watchdog, working times surveillance, CPU temperature and input/output status	
Redundancy	Optional	
General Data		
Dimensions (H/W/D)	1,005 / 860 / 360 mm	2,000 / 800 / 800 mm
Weight ⁽²⁾	120 kg	460 kg
Protection class	IP65	
Impact resistance	IK10	
Overvoltage protection	Type 2	
Installation	Wall	Ground
Operating temperature	-20 to 50 °C / -4 to 122 °F	
Storage temperature	-25 to 60 °C / -13 to 140 °F	
Relative humidity (non-condensing)	10 - 90%	
Maximum altitude ⁽⁵⁾	2,000 m	
Marking	CE	
Standards	IEC 61000-4-30, IEC 62586-1, IEC 61131-3, IEC 60204-1, IEC 61439	

Notes: ⁽¹⁾ For voltages greater than 30% of the nominal voltage ⁽²⁾ Values measured with the highest possible number of hardware elements inside ⁽³⁾ If the installation does not feature an energy storage system, the autonomy will be 2 seconds ⁽⁴⁾ For other configurations, please contact Ingeteam's solar sales department ⁽⁵⁾ For installations beyond the maximum altitude, please contact Ingeteam's solar sales department.

A set of perfectly built-in software tools, specifically designed for developing Supervisory, Control and Data Acquisition Systems (SCADAs) and Human-machine Interfaces (HMIs)

The best way to control your PV plants

Web-based

Customers do not have to install any software on their PC. The PV plant pages can be viewed by using a simple web browser

Redundant

INGECON® SUN SCADA can be set-up in a hot-redundancy configuration. This configuration foresees two servers that continuously synchronize data between them. When the main server goes down the backup server is ready to take its place and all the connected clients are automatically redirected to it.

Platform independent

The pages can be viewed from any device and with any operating system. Customers can use a standard PC, laptop with Windows, Linux or MAC OS as well as an Android or iOS Smartphone/ tablet

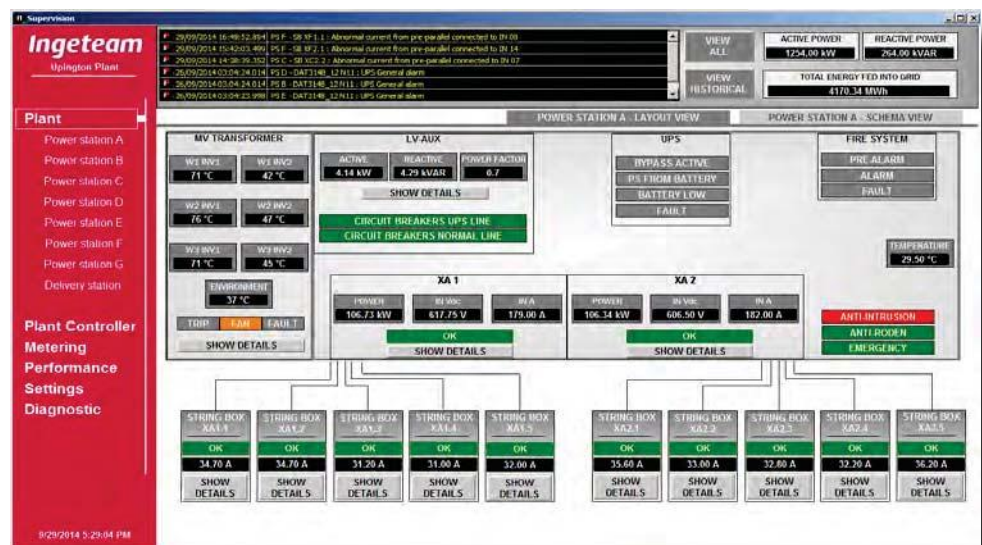

Alarm management

The system can handle all the alarms from the PV plant. Each alarm can be associated with one or more notifications in order to send critical information to the user via SMS, e-mail or voice call.

Remote maintenance

All the upgrades, enhancements and modifications on the system can be made by connecting to the runtime server via web browser without stopping it. This allows the customer to save money because this kind of operations can be done without a single minute of downtime. Moreover it is not necessary to install a dedicated engineering machine in the control room because the modifications can be done directly on the running machine.

Surveillance

It is possible to integrate the system with the live streaming of all the TCP webcams installed in the PV plant. In this way the operator can overlook what is happening on the plant without switching from the SCADA system to the 3rd-party surveillance software.



Security

The operation on each element like buttons, images, menu can be associated to a user level in order to prevent manipulation from unauthorized users.

Reporting engine

The system is capable of storing historical data in most widely used database engines. Stored data as well as online data can be easily presented in a report format directly in the supervision page. The reports can also be exported to excel, csv or can be printed locally or via cloud - if the server is connected to the Web.

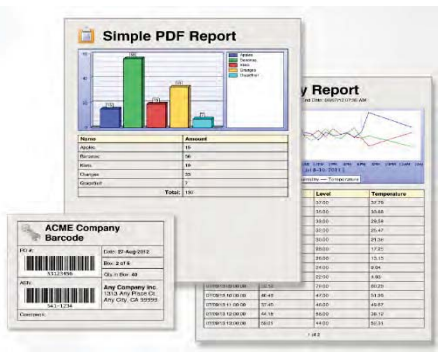

Production forecast

INGECON® SUN SCADA can talk with meteo services in order to understand how the weather conditions on the PV plant will be. This information, together with the plant information, are merged to produce detailed forecast reports.

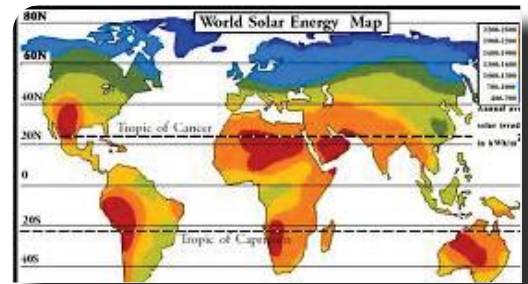

System performance measurement

INGECON® SUN SCADA is capable to collect every important data regarding the plant production. All the data are used to calculate system performance and produce KPI reports like Performance Ratio and Availability in the format requested from the stakeholders.

Predictive maintenance

INGECON® SUN SCADA is capable to collect every important data regarding the PV plant performance and the weather conditions. These data together with the standard maintenance program defined by the customer will produce a detailed maintenance plan that can be used by the O&M team in order to perform the correct maintenance operations when they are needed.



Standalone solution

In this case the server is installed in one of the PV plant buildings (usually a control room). Customers access the supervision system from every machine that has an ethernet access to the plant (direct access or via VPN)

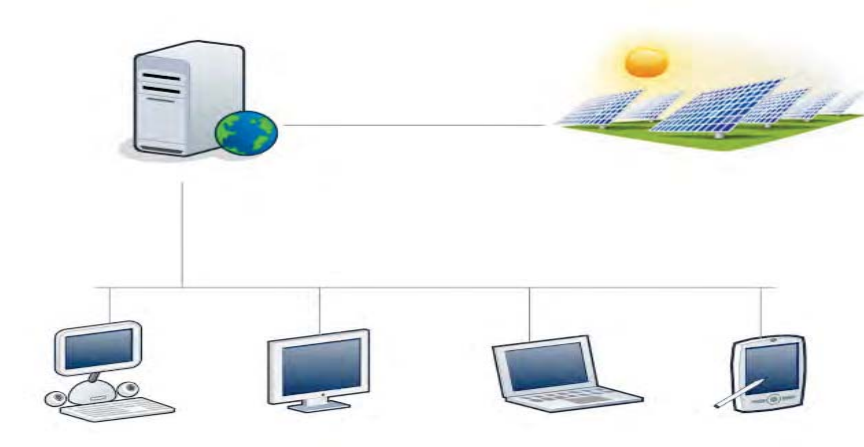

Cloud solution

This solution foresees a small hardware installed in the PV plant that acquires data from all the devices and send them to one of the Ingeteam cloud servers. Customers can access their PV plants by simply entering a user name and password on the server.

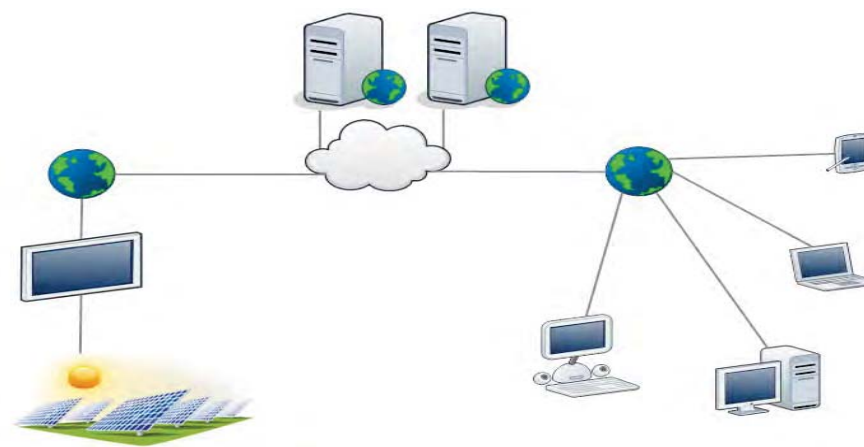

ARG7H1R 1,8/3 kV - 18/30 kV

MEDIA TENSIONE - SENZA PIOMBO
MEDIUM VOLTAGE - LEAD-FREE



NON PROPAGANTE
LA FIAMMA
FLAME RETARDANT



SENZA PIOMBO
LEAD-FREE

RIFERIMENTO NORMATIVO/STANDARD REFERENCE

Costruzione e requisiti/Construction and specifications	IEC 60502 CEI 20-13
Misura delle scariche parziali/Measurement of partial discharges	CEI 20-16 IEC 60885-3
Propagazione fiamma/Flame propagation	CEI EN 60332-1-2
Gas corrosivi o alogenidrici/Corrosive gases or halogens	CEI EN 50267-2-1

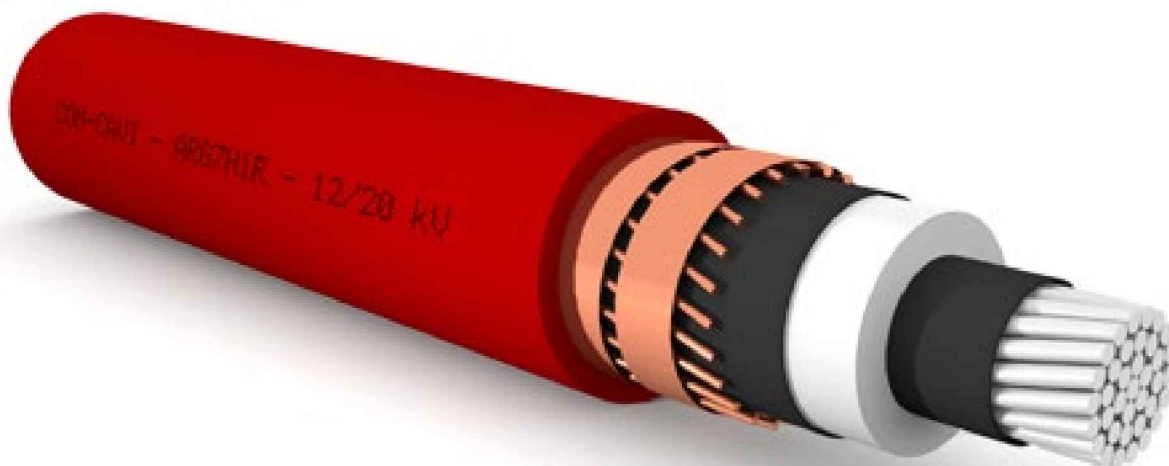

Le immagini sono puramente illustrative e coperte da copyright ©

DESCRIZIONE:

Cavi unipolari isolati in gomma HEPR di qualità G7, sotto guaina di PVC

CARATTERISTICHE FUNZIONALI:

- Tensione nominale U_0/U : 1,8/3 ÷ 18/30 kV
- Temperatura massima di esercizio: 90°C
- Temperatura minima di esercizio: -15°C (in assenza di sollecitazioni meccaniche)
- Temperatura minima di posa: 0°C
- Temperatura massima di corto circuito: 250°C
- Raggio minimo di curvatura consigliato: 12 volte il diametro del cavo.
- Massimo sforzo di trazione consigliato: 50 N/mm² di sezione

CONDIZIONI DI IMPIEGO:

Adatto per il trasporto di energia tra le cabine di trasformazione e le grandi utenze. Per posa in aria libera, in tubo o canale. Ammessa la posa interrata anche non protetta, in conformità all'art. 4.3.11 della norma CEI 11-17.

DESCRIPTION:

Single-core cables, insulated with HEPR rubber of G7 quality, under PVC sheath.

FUNCTIONAL CHARACTERISTICS

- Nominal voltage U_0/U : 1,8/3 ÷ 18/30 kV
- Maximum operating temperature: 90°C
- Min. operating temperature: -15°C (without mechanical shocks)
- Minimum installation temperature: 0°C
- Maximum short circuit temperature: 250°C
- Recommended minimum bending radius: 12 times the cable diameter.
- Recommended maximum tensile stress: 50 N/mm² of the cross-section

USE AND INSTALLATION

Suitable for energy transmission between transformer rooms and big power users. For laying on air, into tube or open pass. Can be laid underground, also if not protected, complying with art. 4.3.11 of CEI 11-17 standard.

ARG7H1R 1,8/3 kV - 18/30 kV

COSTRUZIONE DEL CAVO / CABLE CONSTRUCTION



CONDUTTORE

Materiale: Alluminio, formazione rigida compatta, classe 2

CONDUCTOR

Material: Aluminum, compact stranded wire, class 2



STRATO SEMICONDUCTORE

Materiale: Estruso (solo cavi $U_0/U \geq 6/10$ kV)

SEMICONDUCTOR LAYER

Material: Extruded (only cables $U_0/U \geq 6/10$ kV)



ISOLAMENTO

Materiale: Gomma HEPR, qualità G7, **SENZA PIOMBO** (HD 620 DHI 2)

INSULATION

Material: : HEPR rubber, G7 quality, **LEAD FREE** (HD 620 DHI 2)



STRATO SEMICONDUCTORE

Materiale: Estruso, pelabile a freddo (solo cavi $U_0/U \geq 6/10$ kV)

SEMICONDUCTOR LAYER

Material: Extruded, cold stripping (only cables $U_0/U \geq 6/10$ kV)



SCHERMO

Tipo: Fili di rame rosso, con nastro di rame in controspirale

SCREEN

Type: Plain copper wires with helically wound copper tape



GUAINA ESTERNA

Materiale: Miscela a base di PVC, qualità Rz
Colore: Rosso

OUTER SHEATH

Material: PVC based compound, Rz quality
Colour: Red

N.B. Il cavo può essere fornito nella versione tripolare riunito ad elica visibile. In tal caso la sigla di designazione diventa ARG7H1RX seguita dalla tensione nominale di esercizio.
N.B. The cable can be built in the three-pole version with helically wound cores. In this case, the initials becomes ARG7H1RX, followed by rated voltage.

ARG7H1R 18/30 kV

Caratteristiche tecniche/Technical characteristics U max: 36 kV

Formazione Size	Ø indicativo conduttore Approx. conduct. Ø	Spessore medio isolante Average insulation thickness	Ø esterno max Max outer Ø	Peso indicativo cavo Approx. cable weight	Portata di corrente Current rating			
					A			
					in aria In air		interrato* buried*	
n° x mm ²	mm	mm	mm	kg/km	a trifoglio trefoil	in piano flat	a trifoglio trefoil	in piano flat
1 X 35	7,0	8,0	33,5	1030,0	144,0	152,0	142,0	149,0
1 x 50	8,1	8,0	34,1	1150,0	174,0	183,0	168,0	177,0
1 x 70	9,7	8,0	36,2	1300,0	218,0	229,0	207,0	218,0
1 x 95	11,4	8,0	38,2	1450,0	266,0	280,0	247,0	260,0
1 x 120	12,9	8,0	40,0	1650,0	309,0	325,0	281,0	296,0
1 x 150	14,3	8,0	41,0	1800,0	352,0	371,0	318,0	335,0
1 x 185	16,0	8,0	43,1	2020,0	406,0	427,0	361,0	380,0
1 x 240	18,3	8,0	45,0	2300,0	483,0	508,0	418,0	440,0
1 x 300	21,0	8,0	47,0	2620,0	547,0	576,0	472,0	497,0
1 x 400	23,6	8,0	51,1	3080,0	640,0	674,0	543,0	572,0
1 x 500	26,5	8,0	53,0	3630,0	740,0	779,0	621,0	654,0
1 x 630	30,1	8,0	60,2	4250,0	862,0	907,0	706,0	743,0

*Resistività termica del terreno 100°C cm/W

* Ground thermal resistivity 100°C cm/W

Caratteristiche elettriche/Electrical characteristics

Formazione Size	Resistenza elettrica a 20°C Max. electrical resistance at 20°C	Resistenza apparente a 90°C e 50Hz Conductor apparent resistance at 90°C and 50Hz		Reattanza di fase Phase reactance		Capacità a 50Hz Capacity at 50Hz
		a trifoglio trefoil	in piano flat	a trifoglio trefoil	in piano flat	
		Ω/Km	Ω/Km	Ω/Km	Ω/Km	
1 X 35	0,868	1,113	1,113	0,16	0,21	0,15
1 x 50	0,641	0,822	0,822	0,15	0,20	0,15
1 x 70	0,443	0,568	0,568	0,14	0,20	0,16
1 x 95	0,320	0,411	0,411	0,13	0,19	0,18
1 x 120	0,253	0,325	0,325	0,13	0,18	0,19
1 x 150	0,206	0,265	0,265	0,12	0,18	0,20
1 x 185	0,164	0,211	0,211	0,12	0,18	0,22
1 x 240	0,125	0,161	0,161	0,11	0,17	0,24
1 x 300	0,100	0,130	0,129	0,11	0,17	0,27
1 x 400	0,0778	0,102	0,101	0,11	0,16	0,29
1 x 500	0,0605	0,0801	0,0794	0,10	0,16	0,32
1 x 630	0,0469	0,0635	0,0625	0,099	0,16	0,36

ARG7H1OR 3,6/6 kV - 12/20 kV - 18/30 kV

MEDIA TENSIONE - SENZA PIOMBO
MEDIUM VOLTAGE - LEAD-FREE



NON PROPAGANTE
LA FIAMMA
FLAME RETARDANT



SENZA PIOMBO
LEAD-FREE

RIFERIMENTO NORMATIVO/STANDARD REFERENCE

Costruzione e requisiti/Construction and specifications	IEC 60502 CEI 20-13
Misura delle scariche parziali/Measurement of partial discharges	CEI 20-16 IEC 60885-3
Propagazione fiamma/Flame propagation	CEI EN 60332-1-2
Gas corrosivi o alogenidrici/Corrosive gases or halogens	CEI EN 50267-2-1

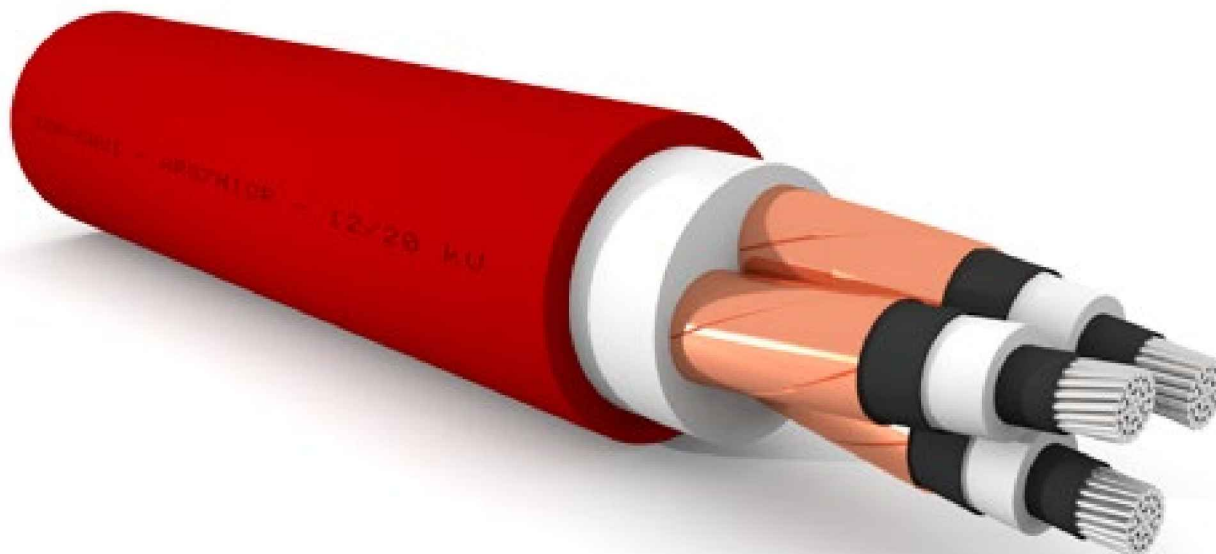

Le immagini sono puramente illustrative e coperte da copyright ©

DESCRIZIONE:

Cavi tripolari isolati in gomma HEPR di qualità G7, sotto guaina di PVC.

CARATTERISTICHE FUNZIONALI:

- Tensione nominale U_0/U : 3,6/6 - 12/20 - 18/30 kV
- Temperatura massima di esercizio: 90°C
- Temperatura minima di esercizio: -15°C (in assenza di sollecitazioni meccaniche)
- Temperatura minima di posa: 0°C
- Temperatura massima di corto circuito: 250°C
- Raggio minimo di curvatura consigliato: 12 volte il diametro del cavo.
- Massimo sforzo di trazione consigliato: 60 N/mm² di sezione del rame

CONDIZIONI DI IMPIEGO:

Adatto per il trasporto di energia tra le cabine di trasformazione e le grandi utenze. Per posa in aria libera, in tubo o canale. Ammessa la posa interrata anche non protetta, in conformità all'art. 4.3.11 della norma CEI 11-17

DESCRIPTION:

Three-pole cables insulated with HEPR rubber of G7 quality, under PVC sheath.

FUNCTIONAL CHARACTERISTICS

- Nominal voltage U_0/U : 3,6/6 - 12/20 - 18/30 kV
- Maximum operating temperature: 90°C
- Min. operating temperature: -15°C (without mechanical shocks)
- Minimum installation temperature: 0°C
- Maximum short circuit temperature: 250°C
- Recommended minimum bending radius: 12 times the cable diameter.
- Recommended maximum tensile stress: 60 N/mm² of the cross-section of the copper

USE AND INSTALLATION

Suitable for energy transmission between transformer rooms and big power users. For laying on air, into tube or open pass. Can be laid underground, also if not protected, complying with art. 4.3.11 of CEI 11-17 standard.

ARG7H1OR 3,6/6 kV - 12/20 kV - 18/30 kV

COSTRUZIONE DEL CAVO / CABLE CONSTRUCTION



CONDUTTORE

Materiale: Alluminio, formazione rigida compatta, classe 2

CONDUCTOR

Material: Aluminum, compact stranded wire, class 2



STRATO SEMICONDUCTORE

Materiale: Estruso (solo cavi $U_0/U \geq 6/10$ kV)

SEMICONDUCTOR LAYER

Material: Extruded (only cables $U_0/U \geq 6/10$ kV)



ISOLAMENTO

Materiale: Gomma HEPR, qualità G7, **SENZA PIOMBO** (HD 620 DHI 2)

INSULATION

Material: HEPR rubber, G7 quality, **LEAD FREE** (HD 620 DHI 2)



STRATO SEMICONDUCTORE

Materiale: Estruso, pelabile a freddo (solo cavi $U_0/U \geq 6/10$ kV)

SEMICONDUCTOR LAYER

Material: Extruded, cold stripping (only cables $U_0/U \geq 6/10$ kV)



SCHERMO

Tipo: Nastri di rame rosso avvolti

SCREEN

Type: Plain copper tapes wrapped



CORDATURA TOTALE

Tipo: I conduttori isolati sono cordati insieme

TOTAL CABLING

Type: The cores are stranded together in concentric lay



RIEMPITIVO

Materiale: Estruso penetrante tra le anime

FILLER

Material: Extruded, penetrating between the cores



GUAINA ESTERNA

Materiale: Mescola a base di PVC, qualità Rz
Colore: Rosso

OUTER SHEATH

Material: PVC based compound, Rz quality
Colour: Red

ARG7H1OR 12/20 kV

Caratteristiche tecniche/Technical characteristics U max: 24 kV

Formazione	Ø indicativo conduttore	Spessore medio isolante	Ø esterno max	Peso indicativo cavo	Portata di corrente	
Size	Approx. conduct. Ø	Average insulation thickness	Max outer Ø	Approx. cable weight	Current rating	
n° x mm ²	mm	mm	mm	kg/km	in aria / In air	interrato* / buried*
3 X 25	6,10	5,5	48,10	2950,0	125,0	115,0
3 x 35	7,0	5,5	50,40	3254,0	150,0	145,0
3 x 50	8,1	5,5	52,80	3595,0	175,0	175,0
3 x 70	9,7	5,5	56,45	4168,0	220,0	210,0
3 x 95	11,4	5,5	60,70	4841,0	265,0	255,0
3 x 120	12,9	5,5	64,95	5617,0	305,0	290,0
3 x 150	14,3	5,5	68,05	6120,0	345,0	320,0
3 x 185	16,0	5,5	72,20	7029,0	406,0	360,0
3 x 240	18,3	5,5	78,90	8404,0	470,0	420,0
3 x 300	21,0	5,5	83,95	9588,0	590,0	500,0
3 X 400	23,6	5,5	91,40	11853,0	640,0	543,0

*Resistività termica del terreno 100°C cm/W

* Ground thermal resistivity 100°C cm/W

Caratteristiche elettriche/Electrical characteristics

Formazione	Resistenza elettrica a 20°C	Resistenza apparente a 90°C e 50Hz	Reattanza di fase	Capacità a 50Hz
Size	Max. electrical resistance at 20°C	Conductor apparent resistance at 90°C and 50Hz	Phase reactance	Capacity at 50Hz
n° x mm ²	Ω/Km	Ω/Km	Ω/Km	μF/km
3 X 25	1,20	1,222	0,21	0,17
3 x 35	0,868	1,113	0,20	0,17
3 x 50	0,641	0,822	0,19	0,18
3 x 70	0,443	0,568	0,19	0,21
3 x 95	0,320	0,411	0,18	0,23
3 x 120	0,253	0,325	0,18	0,25
3 x 150	0,206	0,265	0,17	0,27
3 x 185	0,164	0,211	0,17	0,29
3 x 240	0,125	0,161	0,16	0,32
3 x 300	0,100	0,130	0,16	0,35
3 X 400	0,0778	0,102	0,16	0,39

ARG7H1OR 18/30 kV

Caratteristiche tecniche/Technical characteristics U max: 36 kV

Formazione	Ø indicativo conduttore	Spessore medio isolante	Ø esterno max	Peso indicativo cavo	Portata di corrente	
Size	Approx. conduct. Ø	Average insulation thickness	Max outer Ø	Approx. cable weight	Current rating	
n° x mm ²	mm	mm	mm	kg/km	in aria / In air	interrato* / buried*
3 x 185	16,0	8,0	85,50	9400,0	406,0	361,0

*Resistività termica del terreno 100°C cm/W

* Ground thermal resistivity 100°C cm/W

Caratteristiche elettriche/Electrical characteristics

Formazione	Resistenza elettrica a 20°C	Resistenza apparente a 90°C e 50Hz	Reattanza di fase	Capacità a 50Hz
Size	Max. electrical resistance at 20°C	Conductor apparent resistance at 90°C and 50Hz	Phase reactance	Capacity at 50Hz
n° x mm ²	Ω/Km	Ω/Km	Ω/Km	μF/km
3 x 185	0,164	0,211	0,12	0,22



1 Introduction

The scope of this documents is to describe typical SAET solutions for Battery Energy Storage System (BESS) including the correct match between battery container and PCS for different C-rate as shown in the following block diagram:

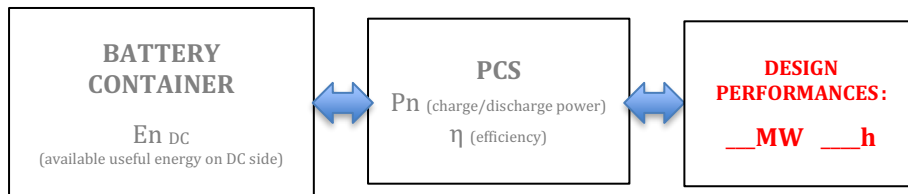

Battery containers and PCS can be arranged in different configurations including all necessary equipment for power connection (LV-MV transformers, MV switchgear, HV equipment if required) and BESS control (Power Management System – PMS).

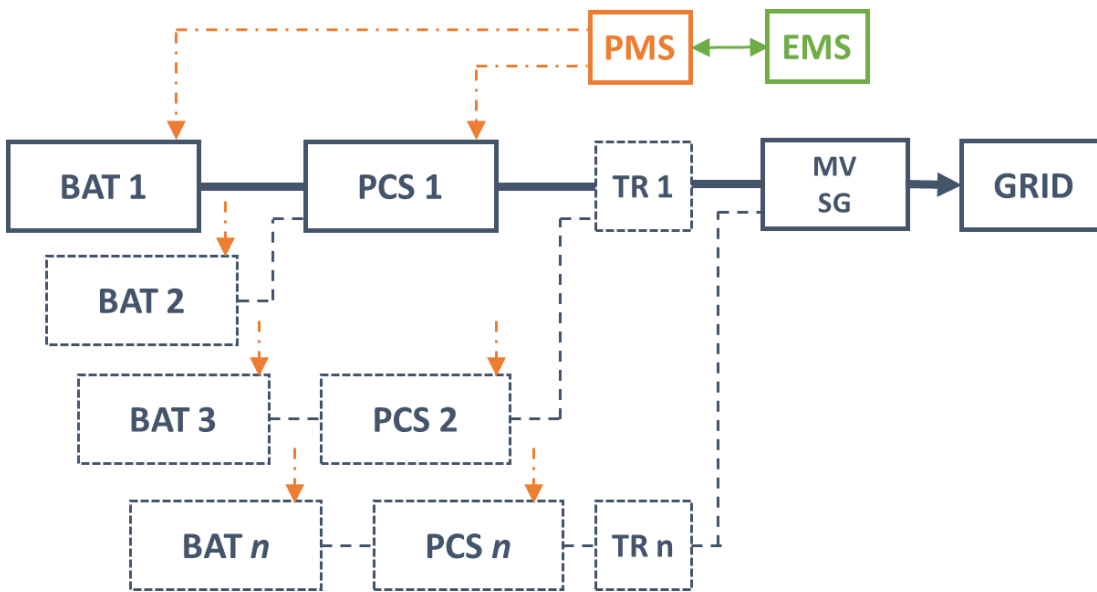

For additional details on plant configuration please contact SAET.

Data shown are used as technical reference performances and dimensions are subject to change during project design stage.

2 Battery Container Specification

Here in the following are reported the features of battery 40ft container.

System Specification - 40ft HC container							
SYSTEM CHARACTERISTICS			C-rate: 0,25	C-rate: 0,5	C-rate: 1	C-rate: 2	
Energy Rating	DC Nominal Energy	MWh	5	5	4	3.2	@ BOL
	Discharge C-Rate	C	0.25	0.5	1.0	2.0	
Power Rating	Maximum Constant Power @ C-rate	MW	1	2.50	4	6	@ BOL
	Nominal discharge duration	hours	4	2	1	0.5	
Battery Voltage	Nominal Voltage	Vdc	1150				
	Voltage Range	Vdc	1000 : 1300				
SOC Range	Recommended range	%	5 % - 95%				
Features system			Module & rack BMS (Battery Module Unit)				
			BPU (Battery Protection Unit)				
			DC coupling panel				
			Fire detection and suppression system				
PHYSICAL CHARACTERISTICS							
Container building	Quantity		1				
	Container dimensions (feet)		40' ISO HC				
	Weight	ton	< 80	< 80	< 80	< 80	(preliminary)
ENVIRONMENTAL CHARACTERISTICS							
Environmental conditions	Operating temperature	°C	- 40 °C to 60 °C				
	Storage temperature	°C	10 °C to 30 °C				
	Installation	-	Outdoor				
Relative Humidity	Maximum humidity	%	up to 95%				
Altitude	Above sea level	m	1000 m				

Access to batteries is done only through external opening of the containers door.

Below list of applied safety standards to battery container:

- UL 9540 – Safety for Energy Storage System and Equipment
- UL 9540A – Test Methods for Evaluating Thermal Runaway Fire Propagation–BESS
- UL 1973 – Batteries For Use in Stationary Applications
- UL 1642 – Standards for Lithium Batteries
- NFPA 70E – Standard for Electrical Safety in the Workplace
- NFPA 551 / NFPA 550 – Fire detection and suppression
- *Other specific national standard on request*



Battery Container HVAC

The cooling of the batteries container is provided with an air-cooling system using a closed circuit; this system permits to keep the internal temperature and humidity at the nominal level.

The system uses “backpack” units for low- and medium-powered exchanges fixed on the short side of battery container. They are distinguished by an innovative air circulation system which significantly enhances performance in all operating conditions.

Fire protection system

Please refer to paragraph 4.

3 PCS Specification

Here in the following are reported the features of PCS and battery container related to the different C-rate.

3.1 PCS 0.25 - Constant Power / 2x 40ft battery container

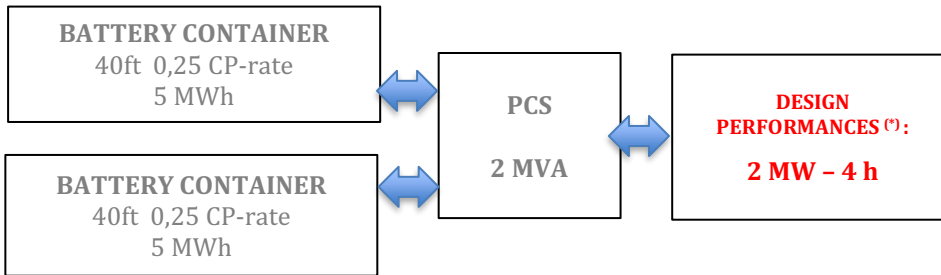

PCS Specification – 2 MVA		
AC		
AC Output Power	<i>kVA/kW</i>	2000
Operating Grid Voltage	<i>Vac</i>	530 V ± 10%
Operating Grid Frequency	<i>Hz</i>	50 / 60
Current Harmonic Distortion	<i>THDi</i>	< 3%
Reactive Power Compensation		Four quadrant operation
DC		
DC Voltage Range	<i>Vdc</i>	1000 - 1300
DC Voltage Ripple	<i>%</i>	< 3%
Number of Separate DC Inputs		2
EFFICIENCY		
Efficiency	<i>%</i>	> 98 %
CABINET		
Dimensions [WxDxH]	<i>mm</i>	3000 x 2000 x 2200
Weight	<i>kg</i>	5200
Type of Ventilation		Forced air cooling
ENVIRONMENT		
Degree of Protection		IP55
Permissible Ambient Temperature		-35°C to +60°C, >50°C / Active power derating
Relative Humidity	<i>%</i>	4% to 100% non-condensing
Max. Altitude (above sea level)		1000m
CERTIFICATIONS & STANDARDS		
Safety		UL 1741 / CSA 22.2 No.107.1-16 / IEC 62109-1 / IEC 62109-2
Utility Interconnect		IEEE 1547:2018 / UL 1741 SB/ IEC 62116:2014

(*) Performances considering 365 cycles/year at PCS AC output power guaranteed up to 5 years. After fifth year performances are reduced based on battery' State of Health (SOH). Additional information or performances upon request. Please contact SAET for further details.

3.2 PCS 0.5 - Constant Power / 1x 40ft battery container

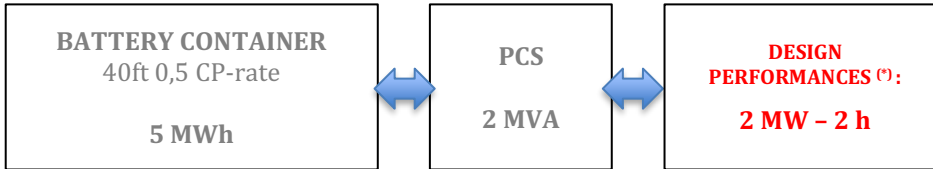

PCS Specification – 2 MVA		
AC		
AC Output Power	kVA/kW	2000
Operating Grid Voltage	V _{ac}	630 V ± 10%
Operating Grid Frequency	Hz	50 / 60
Current Harmonic Distortion	THDi	< 3%
Reactive Power Compensation		Four quadrant operation
DC		
DC Voltage Range	V _{dc}	1000 - 1300
DC Voltage Ripple	%	< 3%
Number of Separate DC Inputs		2
EFFICIENCY		
Efficiency	%	> 98 %
CABINET		
Dimensions [WxDxH]	mm	3000 x 2000 x 2200
Weight	kg	5200
Type of Ventilation		Forced air cooling
ENVIRONMENT		
Degree of Protection		IP55
Permissible Ambient Temperature		-35°C to +60°C, >50°C / Active power derating
Relative Humidity	%	4% to 100% non-condensing
Max. Altitude (above sea level)		1000m
CERTIFICATIONS & STANDARDS		
Safety		UL 1741 / CSA 22.2 No.107.1-16 / IEC 62109-1 / IEC 62109-2
Utility Interconnect		IEEE 1547:2018 / UL 1741 SB/ IEC 62116:2014

(* Performance considering 365 cycles/year at PCS AC output power guaranteed up to 5 years. After fifth year performances are reduced based on battery' State of Health (SOH). Additional information or performances upon request. Please contact SAET for further details.

3.3 PCS 0.5 - Constant Power / 2x 40ft battery container

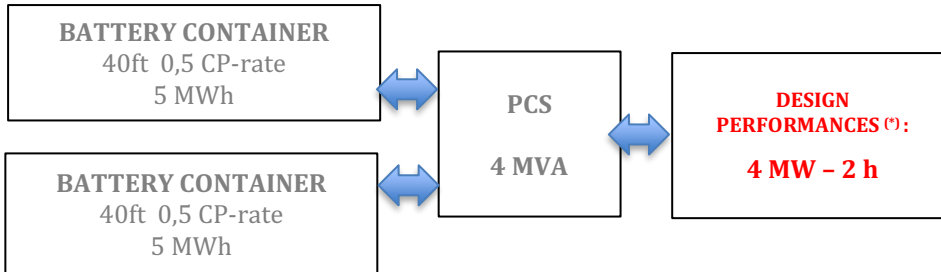

PCS Specification – 4 MVA		
AC		
AC Output Power	kVA/kW	4000
Operating Grid Voltage	Vac	630 V ± 10%
Operating Grid Frequency	Hz	50 / 60
Current Harmonic Distortion	THDi	< 3%
Reactive Power Compensation		Four quadrant operation
DC		
DC Voltage Range	Vdc	1000 - 1300
DC Voltage Ripple	%	< 3%
Number of Separate DC Inputs		4
EFFICIENCY		
Efficiency	%	> 98 %
CABINET		
Dimensions [WxDxH]	mm	3000 x 2000 x 2200
Weight	kg	5200
Type of Ventilation		Forced air cooling
ENVIRONMENT		
Degree of Protection		IP55
Permissible Ambient Temperature		-35°C to +60°C, >50°C / Active power derating
Relative Humidity	%	4% to 100% non-condensing
Max. Altitude (above sea level)		1000m
CERTIFICATIONS & STANDARDS		
Safety		UL 1741 / CSA 22.2 No.107.1-16 / IEC 62109-1 / IEC 62109-2
Utility Interconnect		IEEE 1547:2018 / UL 1741 SB/ IEC 62116:2014

(*). Performances considering 365 cycles/year at PCS AC output power guaranteed up to 5 years. After fifth year performances are reduced based on battery' State of Health (SOH). Additional information or performances upon request. Please contact SAET for further details.

3.4 PCS 1 - Constant Power / 1x 40ft battery container

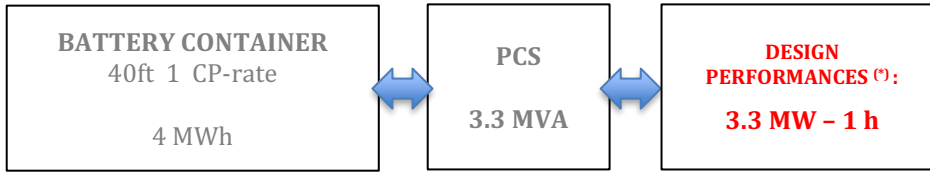

PCS Specification – 3.3 MVA		
AC		
AC Output Power	kVA/kW	3300
Operating Grid Voltage	V _{ac}	530 V ± 10%
Operating Grid Frequency	Hz	50 / 60
Current Harmonic Distortion	THDi	< 3%
Reactive Power Compensation		Four quadrant operation
DC		
DC Voltage Range	V _{dc}	1000 - 1300
DC Voltage Ripple	%	< 3%
Number of Separate DC Inputs		2
EFFICIENCY		
Efficiency	%	> 98 %
CABINET		
Dimensions [WxDxH]	mm	3000 x 2000 x 2200
Weight	kg	5200
Type of Ventilation		Forced air cooling
ENVIRONMENT		
Degree of Protection		IP55
Permissible Ambient Temperature		-35°C to +60°C, >50°C / Active power derating
Relative Humidity	%	4% to 100% non-condensing
Max. Altitude (above sea level)		1000m
CERTIFICATIONS & STANDARDS		
Safety		UL 1741 / CSA 22.2 No.107.1-16 / IEC 62109-1 / IEC 62109-2
Utility Interconnect		IEEE 1547:2018 / UL 1741 SB/ IEC 62116:2014

(* Performance considering 365 cycles/year at PCS AC output power guaranteed up to 5 years. After fifth year performances are reduced based on battery' State of Health (SOH). Additional information or performances upon request. Please contact SAET for further details.

3.5 PCS 2 - Constant Power / 1x 40ft battery container

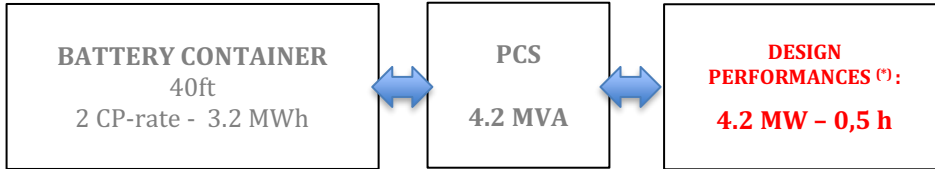

PCS Specification – 4.2 MVA		
AC		
AC Output Power	<i>kVA/kW</i>	4200
Operating Grid Voltage	<i>Vac</i>	660 V ± 10%
Operating Grid Frequency	<i>Hz</i>	50 / 60
Current Harmonic Distortion	<i>THDi</i>	< 3%
Reactive Power Compensation		Four quadrant operation
DC		
DC Voltage Range	<i>Vdc</i>	1000 - 1300
DC Voltage Ripple	<i>%</i>	< 3%
Number of Separate DC Inputs		2
EFFICIENCY		
Efficiency	<i>%</i>	> 98 %
CABINET		
Dimensions [WxDxH]	<i>mm</i>	3000 x 2000 x 2200
Weight	<i>kg</i>	5200
Type of Ventilation		Forced air cooling
ENVIRONMENT		
Degree of Protection		IP55
Permissible Ambient Temperature		-35°C to +60°C, >50°C / Active power derating
Relative Humidity	<i>%</i>	4% to 100% non-condensing
Max. Altitude (above sea level)		1000m
CERTIFICATIONS & STANDARDS		
Safety		UL 1741 / CSA 22.2 No.107.1-16 / IEC 62109-1 / IEC 62109-2
Utility Interconnect		IEEE 1547:2018 / UL 1741 SB/ IEC 62116:2014

(*) Performances considering 365 cycles/year at PCS AC output power guaranteed up to 5 years.
 After fifth year performances are reduced based on battery' State of Health (SOH).
 Additional information or performances upon request. Please contact SAET for further details.

4 Fire safety protection

Protection against major fire events and thermal abnormal situations are based on:

- Installation of battery container far from critical devices of the plant.
- Proper management of ventilation and temperature control of battery container.
- Proper thermal insulation of battery container to avoid unexpected heat transfer.
- Installation of an automatic fire detection system.
- Gas-based fire extinguishing system installed on LV container automatically activated by the smoke detector.
- Availability on site of local fire extinguisher

The BESS container is equipped with the firefighting system that is composed by a detection system, an extinguishing system and a central firefighting unit:

- The detection system is composed by smoke and temperature sensors installed on the ceiling of each room, and by a smoke analyzer unit that are connected to the central fire-fighting unit. In each room there are at least 2 smoke and temperature detection sensors.
- The extinguishing system is composed by the bottles that contains the inert extinguisher gas, the distribution pipes and the nozzles. Each room is provided with the suitable number of nozzles in order to assure an homogeneous saturation of the room.

In case that one sensor detects smoke, the central fire-fighting unit issues the first threshold of alarm that result in to a stop of the BESS, and the issuing of the alarm to the customer supervision system.

In case that two sensors of the same room detect smoke, the central fire-fighting unit issues the second threshold of alarm that result in to a shutdown of the BESS, the releasing of the extinguisher and the issuing of the alarm to the customer supervision system.

Automatic smoke and fire detection system are made of:

- Addressable fire detection control panel.
- Lead backup batteries.

- Electronic smoke detectors.
- Alarm push button.
- Emergency light (visual/acoustic signaling device).
- Emergency buzzer (addressable audio/visual devices).
- Fire resistant cables.

Gas-based fire extinguishing system installed on battery container automatically activated by the smoke detector installed on battery cabinet.

For the extinguishing system will be used an inert gas. The type of used gas is linked to the battery's manufacturer prescriptions. The main characteristic of inert gases (like helium, neon, argon, krypton and xenon) is that of not taking part in chemical reactions and it is for this characteristic that they prevent the development of combustion. Inert gas fire-fighting systems use argon and nitrogen gases and their mixtures as extinguishing agents, with the technique of total saturation of the environment up to a value below which the combustion process cannot to occur, but in any case such as not to constitute a danger for any operators.

Inert gases as extinguishing agents are particularly suitable for the protection of all environments where water cannot be used.

5 BESS installation and erection

The containers and equipment (i.e. battery container, PCS, MV, etc.) could be laid on foundation slabs in reinforced concrete or in elevation on metal structures; this second solution secures the equipment from possible risks of flooding and protects the system more from accumulations of dust.

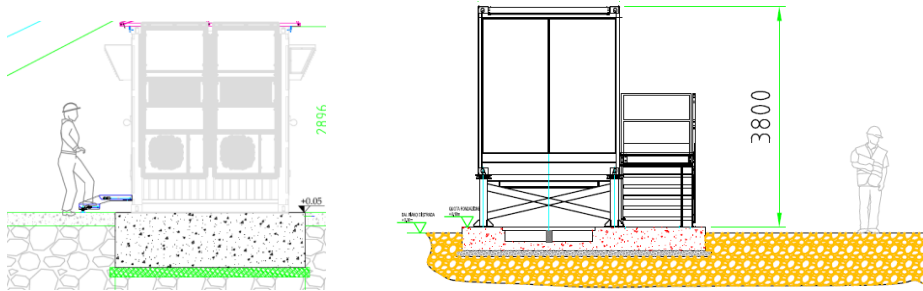

Example of site installation container on the ground or on metal structures

The power and control cables between containers will be laid inside cable ducts obtained from the foundation slabs. For cable external to the foundations slabs they will be covered by means of fiberglass plots or solutions with a pipe embedded in the concrete.

A space of 3 meters per side must be guaranteed around the battery container, to guarantee the assembly and maintenance activities required by the battery container, such as transit and manoeuvring for inserting or extracting the modules.

On the container installation zone no additional treatment are needed except the collection and disposal of the rainwater.

Battery container does not foresee emissions of any kind in terms of gas or liquid during operation.

6 Decommissioning plan

SAET, being active as battery importer is properly enrolled, according to Italian Law “D. Lgs 188/2008” to the Italian battery logbook “Registro Pile e Accumulatori” and selected Italian COBAT consortium to support recycling process including decommissioning activities.

Here after the certification of the subscription to battery logbook:



**RICEVUTA DI AVVENUTA PRESENTAZIONE MEDIANTE INVIO TELEMATICO DELLA PRATICA
DI PRATICA ISCRIZIONE PRODUTTORE NAZIONALE
articolo 14 del il D.Lgs 20 novembre 2008 n. 188**

Pratica PD01-0089734 trasmessa in data 16/04/2019 alle ore 09:34:08 alla CAMERA DI COMMERCIO
INDUSTRIA ARTIGIANATO E AGRICOLTURA DI PADOVA per Pratica Iscrizione Produttore Nazionale.

Il numero di posizione attribuito alla pratica è: **PA01-PD-0000767**.

Impresa: **SAET S.P.A.**
VIA A. MORAVIA 8
SELVAZZANO DENTRO (ITALIA)

Delegato: **GIORGIO ROSSI**
RSSGRG49P19G693I

La presente ricevuta attesta l'avvenuta presentazione della pratica Pile Accumulatori.

In addition, battery manufacturer can also support decommissioning process through its own channels. Depending on the specific situation, existing equipment can be addressed to recycling and/or second life purposes.

In case **no plant refurbishment** is planned, decommissioning activities will be:

Main equipment		Option	Note
Battery Module	Cell Group (LFP)	Option 1, Sell Modules to the company who use it for low voltage & Low cycle application; Option 2, Sell to recycle company	
	Interlink		
	Enclosure		
	Cables		
BMS	BMU, BCU, BAU, HMI	Recycle as electronic equipment	BMS is a critical components, for protection purpose, may not for re-use.
	Fuse, Contactor		
	Disconnecter		
	Shunt / Hall		
	Enclosure, Cables		
Rack frame	Battery Cabinet	Sell to recycle company, full recycled	
Power Cable	Main Power Cable	Sell to recycle company, full recycled	
Container	Container itself	Sell to recycle company, full recycled	
	Cable Bridge / Pipe		
	Accessories		
HVAC	Air conditioner	Sell to recycle company, full recycled	After long life operation, not suggest to re-use
	Air duct		
Fire Suppression System	Detection	Sell to recycle company, full recycled	
	Controller		
	Alerter		
	Suppression (Gas & Battle)	Inspect by authorized company and decide if can re-use or have to recycle	Authorized company also do recycle or re-use service
Power Distribution Cabinet	Cabinet	Sell to recycle company, full recycled	
	Electrical Board		
DC Combiner	Cabinet	Sell to recycle company, full recycled	
	Coper Bar		
	Fuse / Breakers		

In case some **plant refurbishment** is planned, decommissioning activities will be:

Main equipment		Option	Note
Battery Module	Cell Group (LFP)	Option 1, Inspect and re-group modules, continue used for next lifetime with lower capacity performance; Option 2, Sell Modules to the company who use it for low voltage & Low cycle application; Option 2, Sell to recycle company	
	Interlink		
	Enclosure		
	Cables		
BMS	BMU, BCU, BAU, HMI	Recycle as electronic equipment	BMS is a critical components, for protection purpose, may not for re-use.
	Fuse, Contactor		
	Disconnecter		
	Shunt / Hall		
	Enclosure, Cables		
Rack frame	Battery Cabinet	Re-use	
Power Cable	Main Power Cable	Re-use	
Container	Container itself	Re-use	
	Cable Bridge / Pipe		
	Accessories		
HVAC	Air conditioner	Option 1, re-use if performance is good; Option 2, Sell to recycle company, full recycled	After long life operation, not suggest to re-use
	Air duct		
Fire Suppression System	Detection	Re-use after refurbishment	Authorized company also do recycle or re-use service
	Controller		
	Alerter		
	Suppression (Gas & Battle)	Inspect by authorized company and decide if can re-use or have to recycle	
Power Distribution Cabinet	Cabinet	Re-use cabinet; Inspect Electrical Board, re-use after refurbishment	
	Electrical Board		
DC Combiner	Cabinet	Re-use cabinet and coper bar; Replace fuse / breaker	Fuse / breaker is critical components for protection purpose
	Coper Bar		
	Fuse / Breakers		