

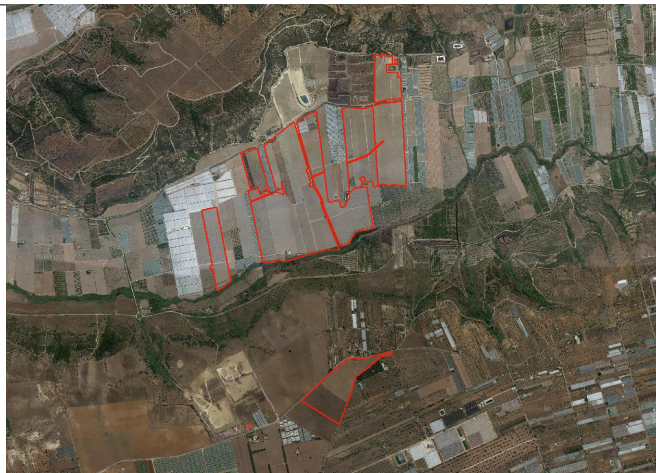

**REGIONE SICILIA  
PROVINCIA RAGUSA  
COMUNE DI ACATE**



**PROGETTO PER LA REALIZZAZIONE DI UN IMPIANTO AGROVOLTAICO SITO IN C/DA PAVAVONE NEL COMUNE DI ACATE, COMPRESO LE OPERE PER LA CONNESSIONE ALLA RETE ELETTRICA IN AT NEL COMUNE DI CHIARAMONTE GULFI (RG)  
POT. IMMISSIONE 38,60 MW - POT. IMPIANTO 38,8332 MWp**

**PROGETTO DEFINITIVO**

**SCHEDE TECNICHE COMPONENTI IMPIANTO FV**

Titolo elaborato

Committente



Sviluppo



Progettazione



Firme



P01/22	PVI1EPD0014A0	P01/Acate/EPD/Sch. comp. impianto	-	A4	001/015
Commessa	Cod. elaborato	Nome file	Scala	Formato	Foglio

00	20.05.2022	Emissione	RS	FB	AN
Rev.	Data	Oggetto revisione	Redatto	Verificato	Approvato

# SCHEDA TECNICA TRACKER

# TRACKER Vanguard™ -1P

## Single-Row



### About TrinaTracker

#### Excellent Bankability

Trina Solar was ranked top in the list of "Top Bankable Module Supplier" released by Bloomberg New Energy Finance (BNF) for five consecutive years

#### Multiple Product Line For All Applications

Multiple product line developed by experienced International R&D team for meeting market demands in all application scenarios

#### Superb Reliability and High Quality Total Solution

Leading quality management system and over 20 years product quality control experience in the industry

#### Efficient Engineering Design Expert

Systematic and high efficient workflow for presales service to guarantee prompt engineering design

#### Unified Product Delivery Service

Global supply chain layout for core equipments in solar farm (modules and tracker) and unified delivery channel for unique experience in customer service



### Compatible with Larger Modules

Vanguard™-1P is designed to reduce LCOE with larger modules. Compatible with modules up to **670W+**



### Highly reliable with strengthened structure

Optimized torque tube improves the torsional resistance by **29.6%** and the bending resistance by **12.4%**



### Less Installation Time & Costs

Trina Clamp is a proprietary product that is quick and easy to use with the 1P configuration, reducing the installation time and costs.



### Highly stable with Bilateral - damper system

The bilateral damper system increases stability and structural flexibility of the tracker, improving the tracking system's resistance to wind gusts from all directions by **20%**.



### Innovative SuperTrack Technology

SuperTrack can improve power generation under highly diffused irradiation weather, reduce generation losses due to row-to-row shading. Up to **8%** yield gain compared with conventional tracking algorithm.

### BILATERAL DAMPER SYSTEM

The bilateral damper system can shorten the tracker oscillation time, thus preventing oscillation. Dynamic responses are reduced and the critical wind speed increased.



### SPHERICAL BEARING

Global patented spherical bearings with up to 30% angle adjustability, alleviate the damage caused by uneven foundation settlement during operations. The spherical bearings dissipate the extra stress caused by the deformation of the tracker system, thus reduce the load and failure rate of each component.



# TECHNICAL SPECIFICATIONS

## GENERAL FEATURES

Solar tracker type	Single row Single-Axis
Tracking range	±60° (120°)
Driver	Slewing driver
Configuration	One module in portrait (1P) up to 90 modules per tracker (1500V string)
Solar module supported	Framed
Foundation options	Direct ramming / Pre-drilling + ramming / Micropile / PHC piles
Pile section	W, compatible with IPE, IPEA, HEA and HEB
Modules attachment	Bolts, Rivets and Clamps
Piles per MW (550Wp module)	~250 piles/MW <sup>(1)</sup> (87 modules per row)
(670Wp module)	~242 piles/MW <sup>(1)</sup> (64 modules per row)
Terrain adaptability	20% N-S <sup>(2)</sup>
Wind and snow loads tolerance	Tailored to site requirement

## STRUCTURE

Material	High Yield Strength Steel
Coating	HDG, Pregalvanized& ZM <sup>(3)</sup>

## CONTROLLER

Controller	Electronic board with microprocessor
Ingress protection marking	IP65
Tracking method	Astronomical algorithms + SuperTrack technology <sup>(4)</sup>
Advanced wind control	Customizable
Anemometer	Cup/Ultrasonic
Night-time stow	Configurable
Communication with the tracker	Wired option: RS485 Wireless option: LoRa/Zigbee
Operating conditions	Altitude < 4000m <sup>(5)</sup> Temperature: -30°C to 60°C <sup>(5)</sup>
Sensors	Digital inclinometer
Power (motor drive)	DC motor: 0.15kW
Power supply	Grid connection / String powered / Self-powered with battery

## WARRANTY

Structure	10 years
Driver and control components	5 years

(1) Depending on layout

(2) For scenarios beyond the scope of use, please consult TrinaTracker

(3) Standard configuration. Other coating under request, please consult TrinaTracker

(4) Includes smart tracking algorithm and smart backtracking algorithm

(5) Standard configuration. Different conditions under request, please consult TrinaTracker

CAUTION: READ SAFETY AND INSTALLATION INSTRUCTIONS BEFORE USING THE PRODUCT.

© 2022 Trina Solar Co.,Ltd. All rights reserved. Specifications included in this datasheet are subject to change without notice.

Doc.number: DT-T-0004 Rev: B

## SCHEDA TECNICA PANNELLO FV

Trina Solar

# INTRODUCTION OF **670W** VERTEX MODULE

## Vertex

High Power

**670W**

High Efficiency

**21.6%**

**Mechanical data**

Size: 2384\*1303mm

Weight: 33.9kg

**Electrical Data**

Low voltage concept design

Voc: 45.7V Isc: 18.5A

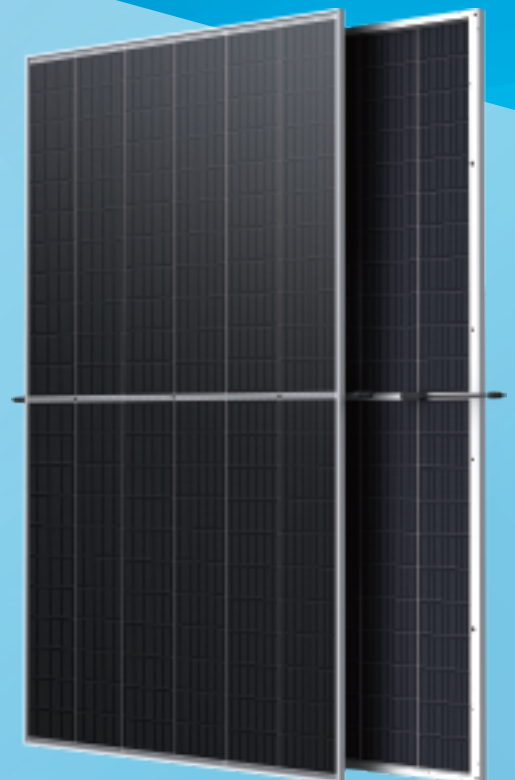

# 210, The Future from Now On!

Vertex module with 670W+ power and 21.6%+ efficiency

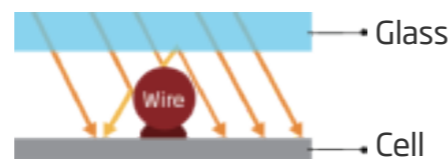
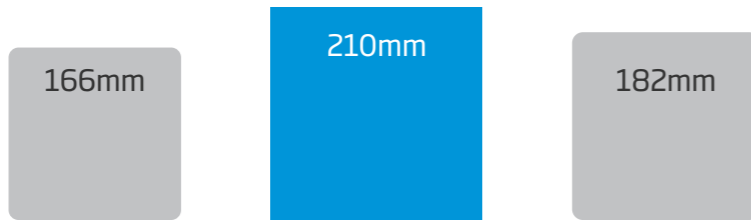

Multi-busbar technology, improving optical utilization rate with higher electricity performance, Module power increase **2~3%**, efficiency increase **0.4~0.6%**

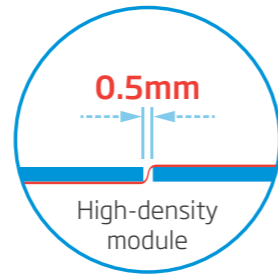
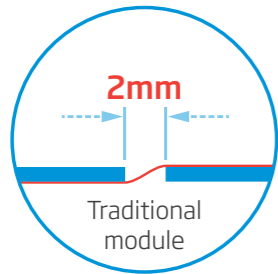

High density encapsulation technology, optimizing power output with good balance between reliability and efficiency, module efficiency increase **0.2~0.3%**

## Non-destructive Cutting(NDC) Technology

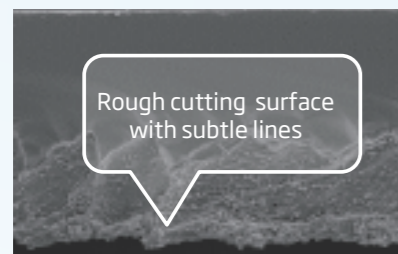

Cross-section from conventional cutting

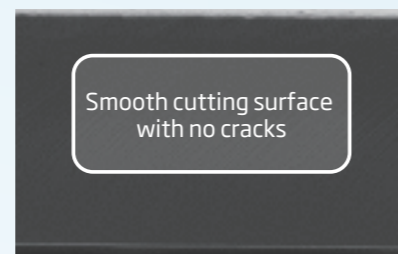

Cross-section from NDC

Achieving better cell strength, lower micro-cracks risk for better product reliability

# LOWER VOLTAGE BRINGS HIGHER STRING POWER **34%**

Module Type	String Module Number	Module Pmax	String Power	Higher Power
210	28	670W	18,760	34%
182	26	540W	14,040	-

**670W**

String Power **18,760W**

28 pcs/string  
53.3 Strings/MW

Rack Steel **33.76 ton/MW**

**VS**

**540W**

String Power **14,040W**

26 pcs/string  
71.4 Strings/MW

Rack Steel **37.15 ton/MW**

# HIGHER STRING POWER BRINGS LOWER COST

## CUSTOMER VALUE OF 670W VERTEX MODULES



### Case study

Location: Minnesota  
 Project Capacity: 100MW  
 Inverter: String Inverter  
 Capacity ratio: 1.2  
 Fixed Tilt



**-15%**  
Racks



**-17%**  
Foundation



**-11%**  
Cable



**-7%**  
installation

	Module Type Power	Reference module 540W	Vertex 670W
<b>BOS(\$/W)</b>	Racks	BL	<b>-0.0035</b>
	Foundation	BL	<b>-0.0015</b>
	Cable	BL	<b>-0.0027</b>
	installation	BL	<b>-0.0053</b>
	Sum	BL	<b>-0.013</b>
<b>LCOE</b>			<b>~ -1.2%</b>

\*Source: Authority expert.

## Logistic cost reduce **12%** per container

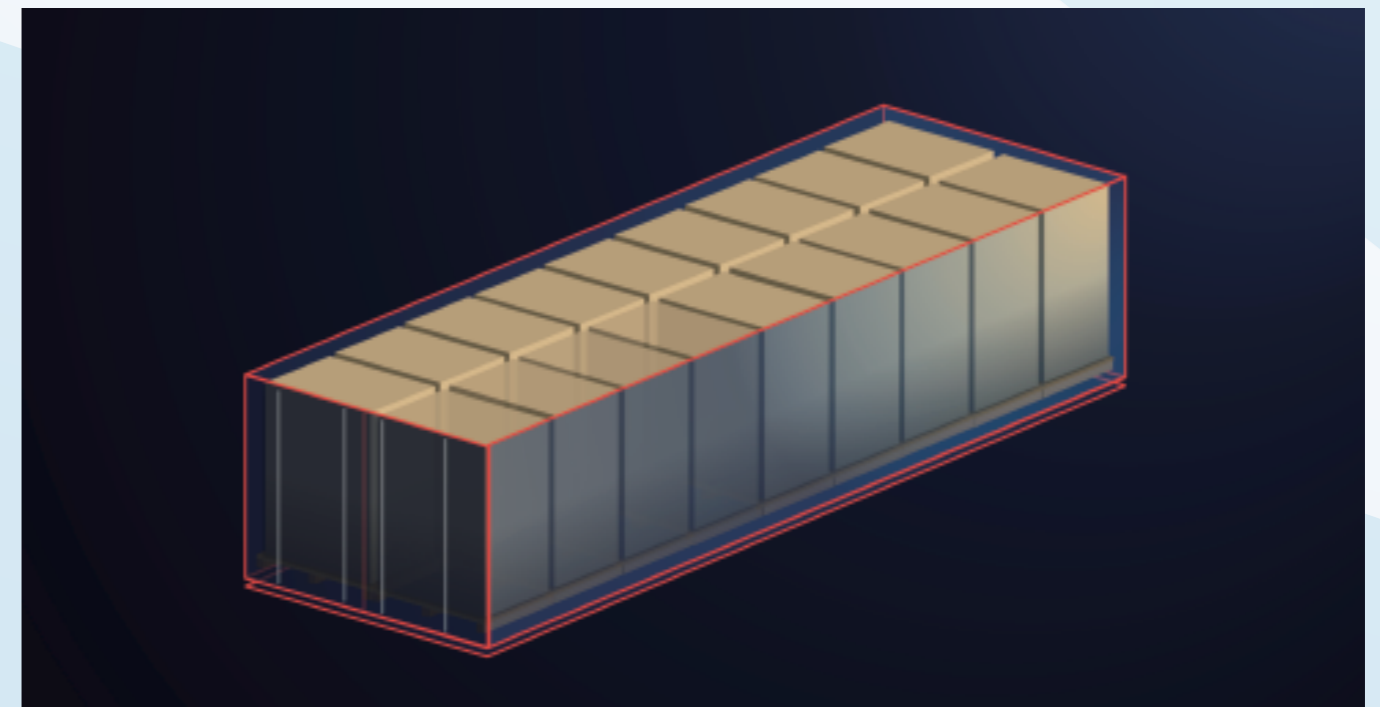
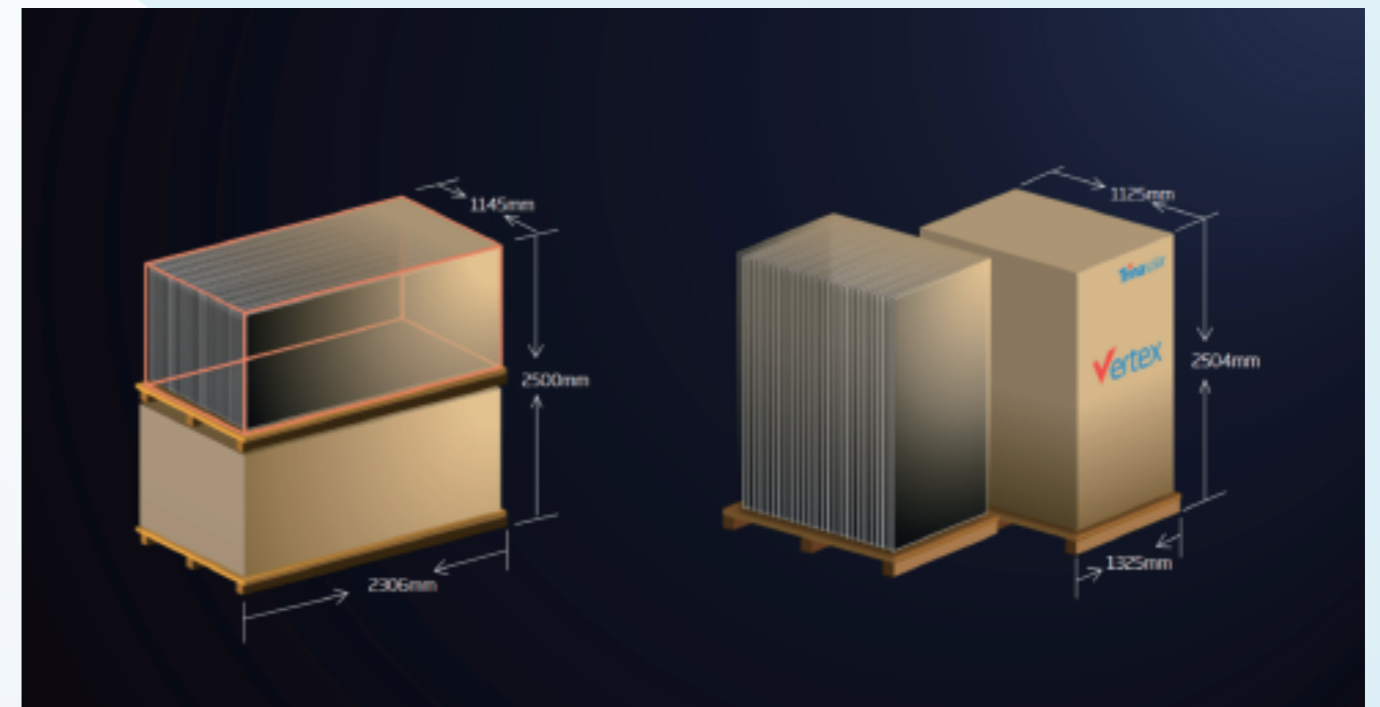

Category	Module Power	Piece per Pallet	Pallet NO. per Container	Power per Container
Other Module	540W	31	20	334,800W
Vertex Module	670W	31	18	373,860W

**+390,60W (+12%)**



## Easy for unpacking and prevent module from falling down

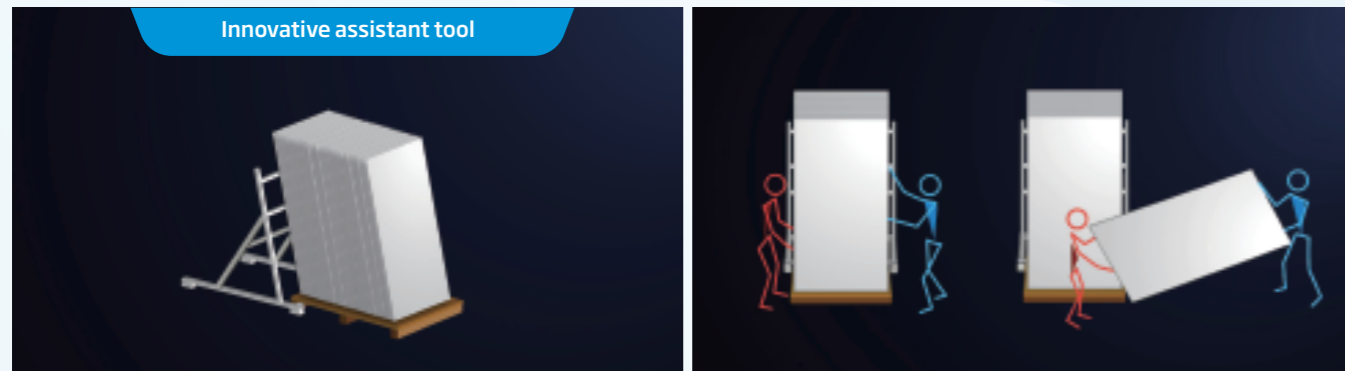

## Manual handling

4 crews/group, same staffing as traditional installation

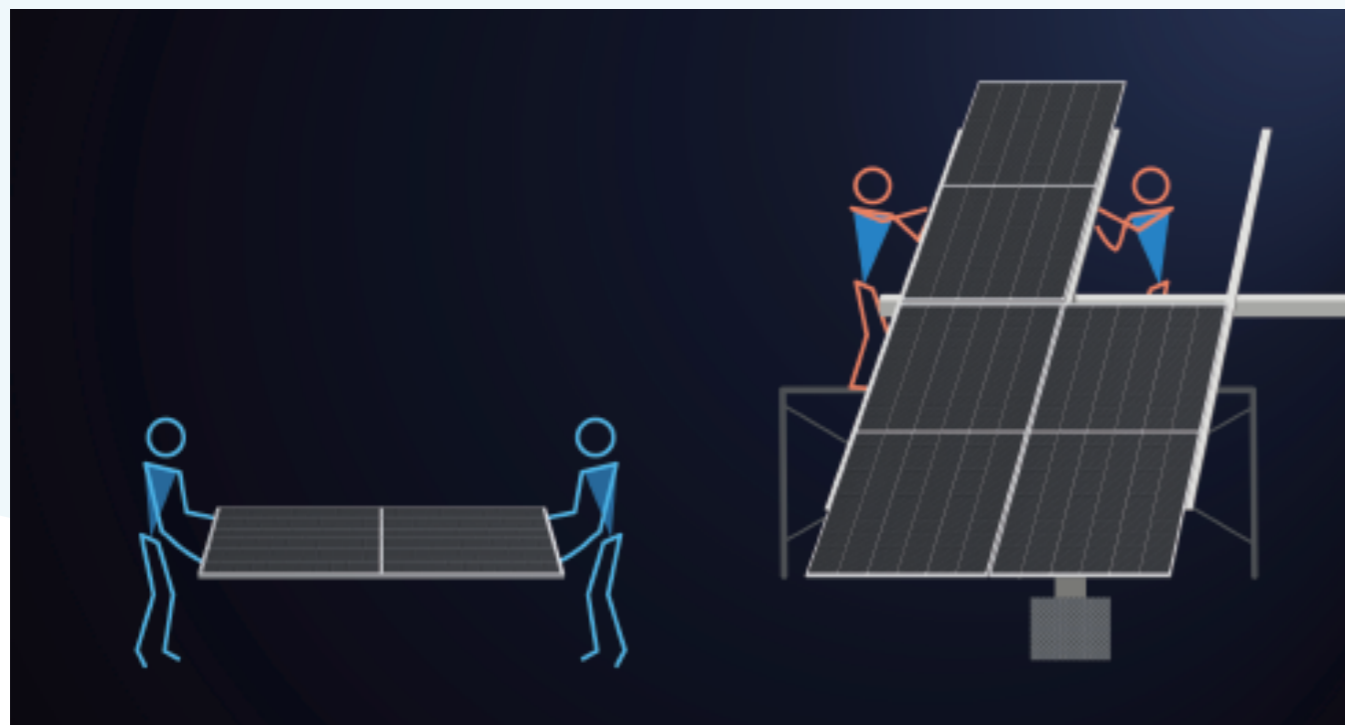

**-24%**

Module installation Quantity

**Installation cost reduction 5-7%**

## ECOSYSTEM IS COMPLETELY IN PLACE

TYPE	BRAND	MODEL	
INVERTER	Central	SUNGROW	1600/2500/3125KW
	String	SUNGROW	SG225HX/SG250HX
		HUAWEI	SUN2000-196KTL-H0/SUN2000-196KTL-H3
		SMA	Sunny Tripower 150-20
		SINENG	SP-225-H/SP-250K-H
COMBINER BOX	LongMax, Bentek, ConnectPV Shoals, SolarBOS	1500V High Current	
CABLE	4MM <sup>2</sup> /6MM <sup>2</sup>		

### CENTRAL INVERTER COMPATIBILITY

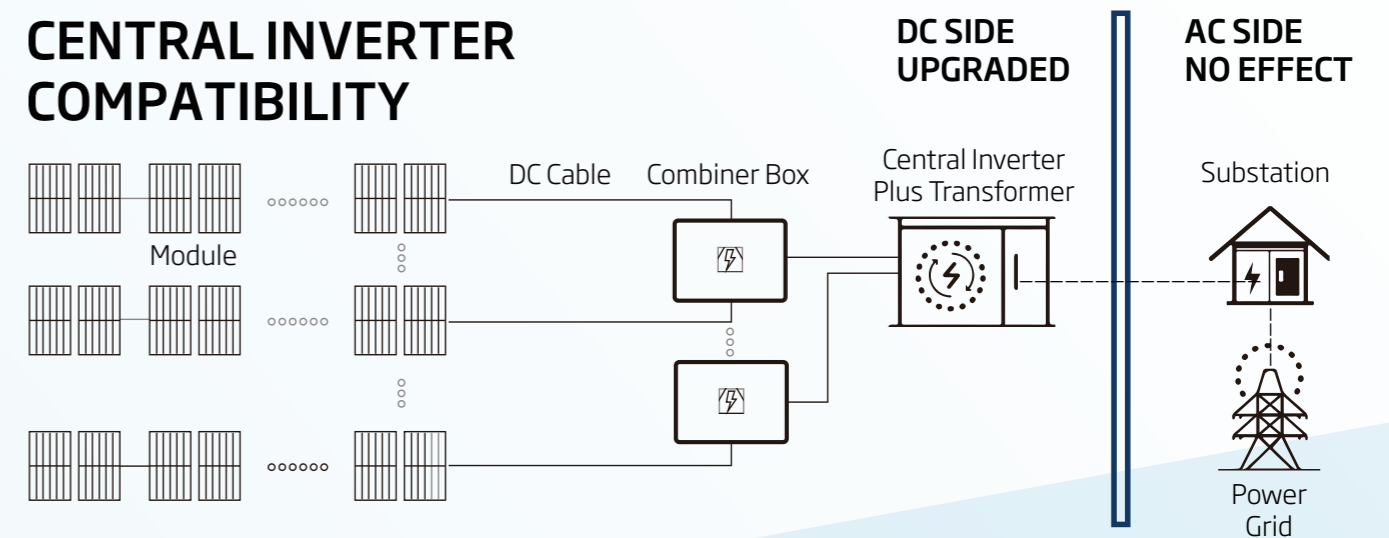

### STRING INVERTER COMPATIBILITY

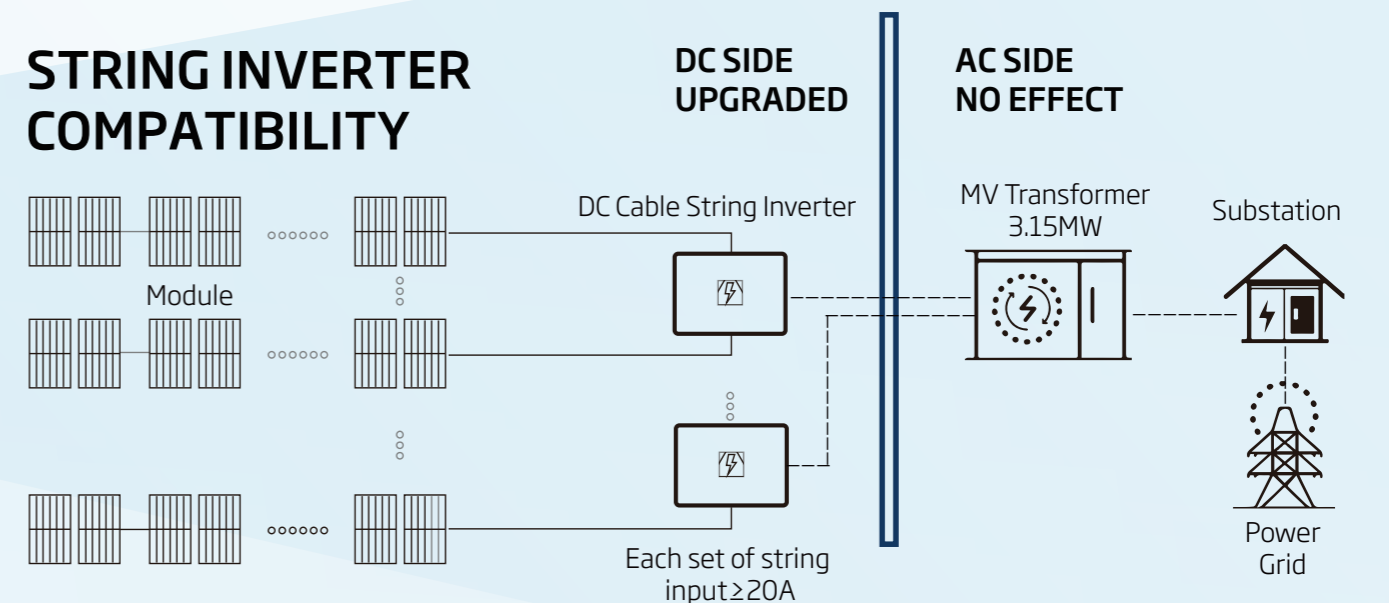

# MECHANICAL LOADING

Compatible with Fixed-tilt and Tracker

**Frame design optimization**

*Conventional Module frame*      *670W Vertex Module frame*

Optimal Design:  
 Optimized frame profile design;  
 Strengthened material;  
 Reinforced supporting bar for backsheet module;  
 Excellent loading performance suits diversified scenarios.

**TÜVRheinland®** IEC 61215, IEC 61730  
 Precisely Right. Received certification in Jan 2021.

**Fix-tilt**      **Tracker**

*Static loading +5400Pa/-2400Pa*      *Static loading +3600Pa/-2400Pa*      *Static loading +2400Pa/-2400Pa*

Company Name	Brand/Product Type	210 Modules
Arcotech Solar Holdings Co., Ltd.	Skyline/Skysmart II	✓
Array Technologies Inc	DuraTrack HZ v3	✓
GameChange Solar LP	GENIUS TRACKER™ 1P/ GENIUS TRACKER™ 2P	✓
IDEEMATEC Deutschland GmbH	H4PLUS™	✓
Nexttracker Inc.	Nexttracker products	✓
PV HARDWARE SOLUTIONS, S.L.U	Independent row: Monoline™ (all its versions 1V, 3H and 2V); Multi-row: Axone™, Axone Duo™	✓
SOLTEC ENERGIAS RENOVABLES S.L.	SF7 & SF8	✓
Trina Solar Co., Ltd	TrinaTracker (Vanguard™/Agile™)	✓
FTC Solar	Voyager/Voyager+	✓
Soltigua	Soltigua products	✓

**Vertex Module Capacity in 2021** **50+ GW**





# Power Beyond Solar

Uif!Xpsme!Mfbejoh!QW!boe!Joufhsbufe!Tnbsu!Fofshz!Tpmvujpo!Qspwjefs



Trina Solar  
Official Website



Vertex Product  
information

For more information regarding Vertex module,  
please follow our social media accounts or  
scan the QR codes to visit us at our website.

## SCHEMA TECNICA INVERTER 215 KVA

# SUN2000-215KTL-H3

## Smart String Inverter



100A  
Per MPPT



99.0%  
Max. Efficiency



String-Smart  
Switch



Smart I-V Curve  
Diagnosis Supported



MBUS  
Supported



Fuse Free  
Design



Surge Arresters for  
DC & AC



IP66  
Protection

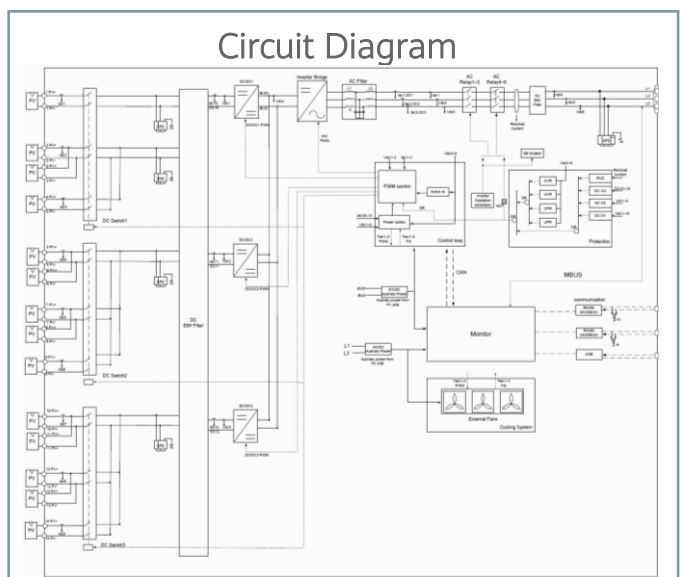
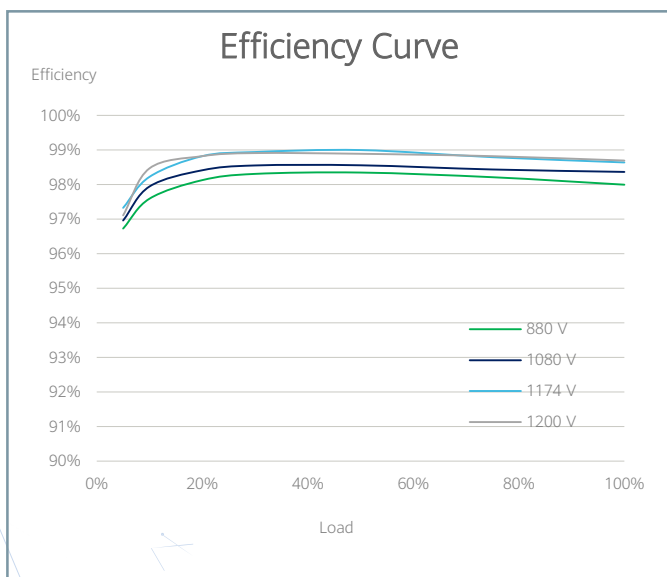

# Technical Specifications

Efficiency	
Max. Efficiency	≥99.0%
European Efficiency	≥98.6%
Input	
Max. Input Voltage	1,500 V
Number of MPP Trackers	3
Max. Current per MPPT	100A/100A/100A
Max. PV Inputs per MPPT	4/5/5
Start Voltage	550 V
MPPT Operating Voltage Range	500 V ~ 1,500 V
Nominal Input Voltage	1,080 V
Output	
Nominal AC Active Power	200,000 W
Nominal Output Voltage	800 V, 3W + PE
Rated AC Grid Frequency	50 Hz / 60 Hz
Nominal Output Current	144.4 A
Adjustable Power Factor Range	0.8 LG ... 0.8 LD
Max. Total Harmonic Distortion	< 1%
Protection	
Input-side Disconnection Device	Yes
Anti-islanding Protection	Yes
AC Overcurrent Protection	Yes
DC Reverse-polarity Protection	Yes
PV-array String Fault Monitoring	Yes
DC Surge Arrester	Type II
AC Surge Arrester	Type II
DC Insulation Resistance Detection	Yes
Residual Current Monitoring Unit	Yes
Communication	
Display	LED Indicators, WLAN + APP
USB	Yes
MBUS	Yes
RS485	Yes
General	
Dimensions (W x H x D)	1,035 x 700 x 365 mm (40.7 x 27.6 x 14.4 inch)
Weight (with mounting plate)	≤86 kg (191.8 lb.)
Operating Temperature Range	-25°C ~ 60°C (-13°F ~ 140°F)
Cooling Method	Smart Air Cooling
Max. Operating Altitude without Derating	4,000 m (13,123 ft.)
Relative Humidity	0 ~ 100%
DC Connector	Staubli MC4 EVO2
AC Connector	Waterproof Connector + OT/DT Terminal
Protection Degree	IP66
Topology	Transformerless

## SCHEDA TECNICA CAVI

**Energia - Applicazioni terrestri e/o eoliche**  
**Power - Ground and/or wind farm applications**

**RG7H1R EPRO-SETTE™**

Unipolare da 1,8/3 kV a 26/45 kV / Single core from 1,8/3 kV to 26/45 kV

**Unipolare da 1,8/3 kV a 45 kV / Single core from 1,8/3 kV to 45 kV**

sezione nominale	diametro indicativo conduttore	spessore isolante	diametro esterno massimo	peso indicativo del cavo	raggio minimo di curvatura	sezione nominale	posa in aria		posa interrata			
conductor cross-section	approximate conductor diameter	insulation thickness	maximum outer diameter	approximate weight	minimum bending radius	conductor cross-section	in piano	a trifoglio	in piano	a trifoglio	in piano	a trifoglio
(mm <sup>2</sup> )	(mm)	(mm)	(mm)	(kg/km)	(mm)	(mm <sup>2</sup> )	open air installation flat	trefoil	flat	trefoil	flat	trefoil
									p=1 °C m/W	p=1 °C m/W	p=2 °C m/W	p=2 °C m/W

**Dati costruttivi / Construction charact. - 18/30 kV**

35	7,0	8,0	34,6	1290	450
50	8,2	8,0	34,8	1390	450
70	9,9	8,0	36,6	1660	480
95	11,6	8,0	38,3	1940	500
120	13,1	8,0	39,8	2230	520
150	14,4	8,0	41,2	2520	540
185	16,1	8,0	43,4	2960	570
240	18,5	8,0	45,8	3560	600
300	21,1	8,0	48,5	4240	640
400	23,9	8,0	51,3	5120	680
500	27,1	8,0	55,3	6300	730
630	30,7	8,0	59,8	7790	790

**Caratt. elettriche / Electrical charact. - 18/30 kV**

35	211	191	187	181	146	142
50	253	229	222	214	172	166
70	316	285	272	263	210	203
95	386	347	325	314	250	242
120	445	400	370	358	283	275
150	505	452	413	400	315	306
185	580	520	467	453	355	345
240	680	614	539	525	408	398
300	775	704	606	593	457	448
400	895	815	684	671	514	506
500	1030	943	775	761	580	572
630	1170	1085	874	860	650	644

**Dati costruttivi / Construction charact. - 26/45 kV**

70	9,9	10,0	42,2	2010	550
95	11,6	10,0	44,3	2360	580
120	13,1	10,0	45,9	2660	600
150	14,4	9,0	45,1	2810	590
185	16,1	9,0	46,9	3220	620
240	18,5	9,0	49,3	3840	650
300	21,1	9,0	52,6	4590	690
400	23,9	9,0	55,1	5440	730
500	27,1	9,0	59,1	6640	780
630	30,7	9,0	63,3	8150	840

**Caratt. elettriche / Electrical charact. - 26/45 kV**

70	318	285	264	256	205	199
95	385	346	315	305	243	237
120	443	398	358	348	275	269
150	502	449	400	389	305	299
185	576	516	451	441	344	338
240	675	609	520	511	395	390
300	769	698	585	575	442	438
400	881	807	661	654	498	495
500	1014	933	742	739	557	558
630	1178	1069	848	836	635	630