

ENGINEERING DRAWING (mm)

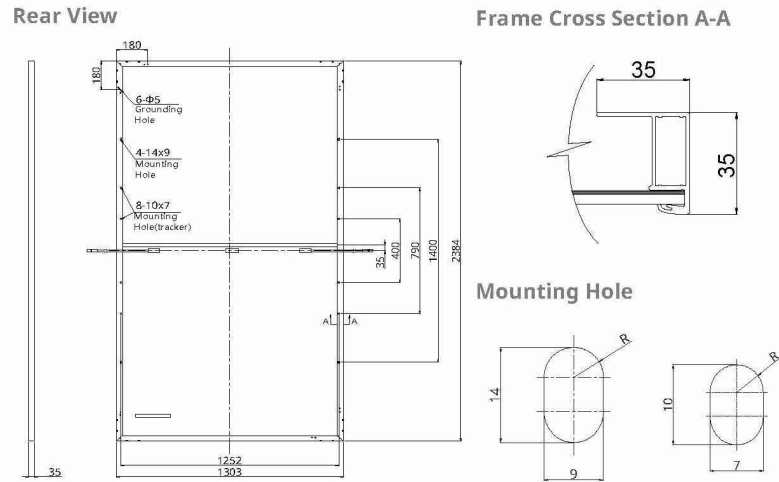

CS7N-650MS / I-V CURVES

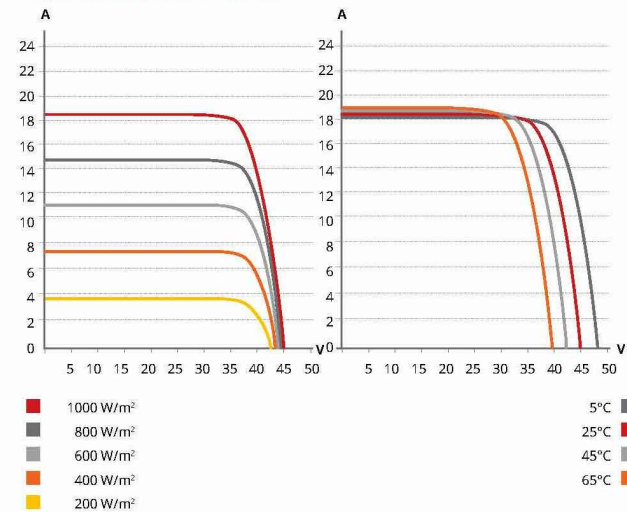

ELECTRICAL DATA | STC\*

CS7N	640MS	645MS	650MS	655MS	660MS	665MS	670MS
Nominal Max. Power (Pmax)	640 W	645 W	650 W	655 W	660 W	665 W	670 W
Opt. Operating Voltage (Vmp)	37.5 V	37.7 V	37.9 V	38.1 V	38.3 V	38.5 V	38.7 V
Opt. Operating Current (Imp)	17.07 A	17.11 A	17.16 A	17.20 A	17.24 A	17.28 A	17.32 A
Open Circuit Voltage (Voc)	44.6 V	44.8 V	45.0 V	45.2 V	45.4 V	45.6 V	45.8 V
Short Circuit Current (Isc)	18.31 A	18.35 A	18.39 A	18.43 A	18.47 A	18.51 A	18.55 A
Module Efficiency	20.6%	20.8%	20.9%	21.1%	21.2%	21.4%	21.6%
Operating Temperature	-40°C ~ +85°C						
Max. System Voltage	1500V (IEC/UL) or 1000V (IEC/UL)						
Module Fire Performance	TYPE 1 (UL 61730 1500V) or TYPE 2 (UL 61730 1000V) or CLASS C (IEC 61730)						
Max. Series Fuse Rating	30 A						
Application Classification	Class A						
Power Tolerance	0 ~ + 10 W						

\* Under Standard Test Conditions (STC) of irradiance of 1000 W/m², spectrum AM 1.5 and cell temperature of 25°C.

MECHANICAL DATA

Specification	Data
Cell Type	Mono-crystalline
Cell Arrangement	132 [2 x (11 x 6)]
Dimensions	2384 x 1303 x 35 mm (93.9 x 51.3 x 1.38 in)
Weight	34.4 kg (75.8 lbs)
Front Cover	3.2 mm tempered glass with anti-reflective coating
Frame	Anodized aluminium alloy, crossbar enhanced
J-Box	IP68, 3 bypass diodes
Cable	4 mm² (IEC), 12 AWG (UL)
Cable Length (Including Connector)	460 mm (18.1 in) (+) / 340 mm (13.4 in) (-) or customized length*
Connector	T6 or T4 series or MC4-EVO2
Per Pallet	31 pieces
Per Container (40' HQ)	527 pieces

\* For detailed information, please contact your local Canadian Solar sales and technical representatives.

ELECTRICAL DATA | NMOT\*

CS7N	640MS	645MS	650MS	655MS	660MS	665MS	670MS
Nominal Max. Power (Pmax)	480 W	484 W	487 W	491 W	495 W	499 W	502 W
Opt. Operating Voltage (Vmp)	35.2 V	35.3 V	35.5 V	35.7 V	35.9 V	36.1 V	36.3 V
Opt. Operating Current (Imp)	13.64 A	13.72 A	13.74 A	13.76 A	13.79 A	13.83 A	13.85 A
Open Circuit Voltage (Voc)	42.2 V	42.3 V	42.5 V	42.7 V	42.9 V	43.1 V	43.3 V
Short Circuit Current (Isc)	14.77 A	14.80 A	14.83 A	14.86 A	14.89 A	14.93 A	14.96 A

\* Under Nominal Module Operating Temperature (NMOT), irradiance of 800 W/m² spectrum AM 1.5, ambient temperature 20°C, wind speed 1 m/s.

TEMPERATURE CHARACTERISTICS

Specification	Data
Temperature Coefficient (Pmax)	-0.34 % / °C
Temperature Coefficient (Voc)	-0.26 % / °C
Temperature Coefficient (Isc)	0.05 % / °C
Nominal Module Operating Temperature	41 ± 3°C

PARTNER SECTION



\* The specifications and key features contained in this datasheet may deviate slightly from our actual products due to the on-going innovation and product enhancement. CSI Solar Co., Ltd. reserves the right to make necessary adjustment to the information described herein at any time without further notice. Please be kindly advised that PV modules should be handled and installed by qualified people who have professional skills and please carefully read the safety and installation instructions before using our PV modules.

CSI Solar Co., Ltd.  
199 Lushan Road, SND, Suzhou, Jiangsu, China, 215129, www.csisolar.com, support@csisolar.com

Regione  
SICILIA



Provincia  
CATANIA



PROGETTO PER LA REALIZZAZIONE DI UN PARCO  
AGRIVOLTAICO E DELLE RELATIVE OPERE  
DI CONNESSIONE ALLA RTN



Comune di Mineo  
Località: "Tre Portelle"

A. PROGETTO DEFINITIVO DELL'IMPIANTO, DELLE  
OPERE CONNESSE E DELLE INFRASTRUTTURE INDISPENSABILI

ELABORATI GRAFICI

Codice:	PTL02	Autorizzazione Unica ai sensi del D.Lgs 387/2003 e D.Lgs 152/2006		
N° elaborato:	A.12.a.22	Schemi funzionali dei singoli pannelli		
N° Foglio	Tot. Fogli	Formato	Scala	Tipo di documento
1	1	A3	-	Progetto Definitivo

Progettazione



Proponente



Rappresentante legale proponente

Emmanuel MACQUERON

Data

Ottobre 2022

Progettisti

Ing. Vassalli Quirino



Ing. Speranza Carmine Antonio



Revisioni	Rev.	Data	Descrizione	Elaborato	Controllato	Approvato
	00	10/2022	Emissione	AS	QV/AS/DR	QI

ITS\_PTL02\_A12a22\_Schemi funzionali dei singoli pannelli.dwg

ITS\_PTL02\_A12a22\_Schemi funzionali dei singoli pannelli.pdf

Il presente elaborato è di proprietà di ITS MEDORA S.r.l. Non è consentito riprodurlo o comunque utilizzarlo senza autorizzazione scritta di ITS MEDORA S.r.l.