

SG250HX PRODUCT DRAWING

Inverter Dimensions

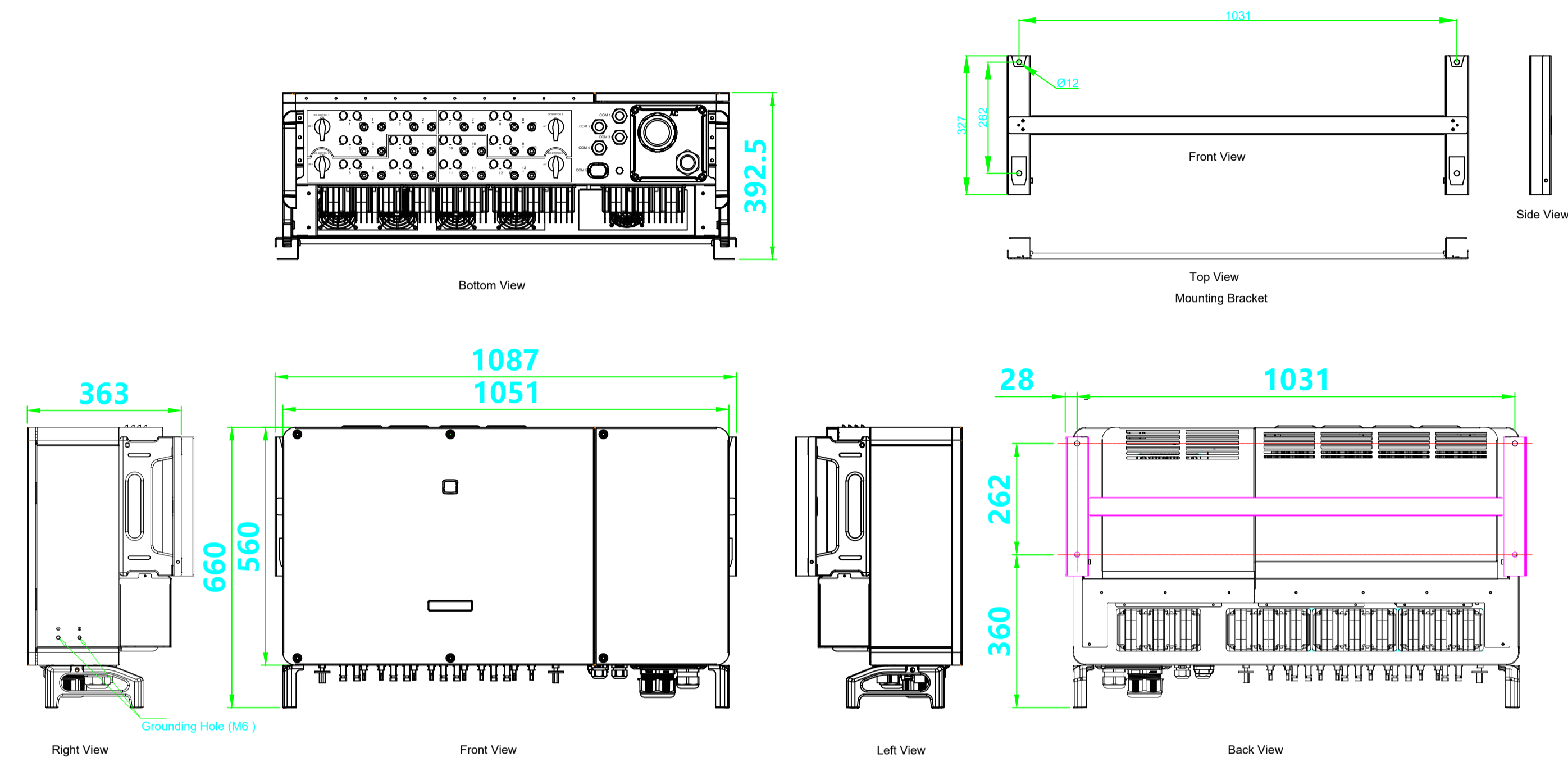

1. The drawing may be not the final version and it is used for reference only. For the final drawing, refer to the documentation in the scope of delivery.
2. Foundations Note : Not for construction. The foundation should be constructed according to onsite conditions as well as local design specifications. The drawings are for information purpose, showing the factors to be considered when designing the foundations; the final engineering drawings must be prepared by professional personal .

Inverter Electrical Diagram

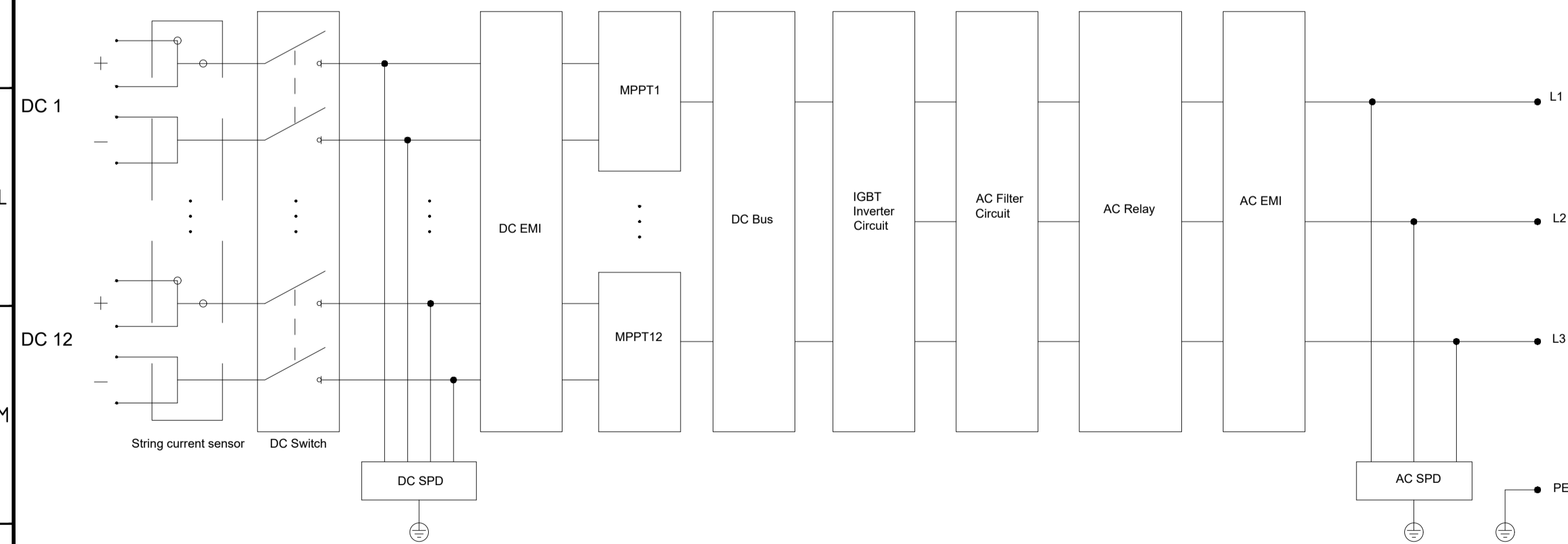

Inverter Internal Layout

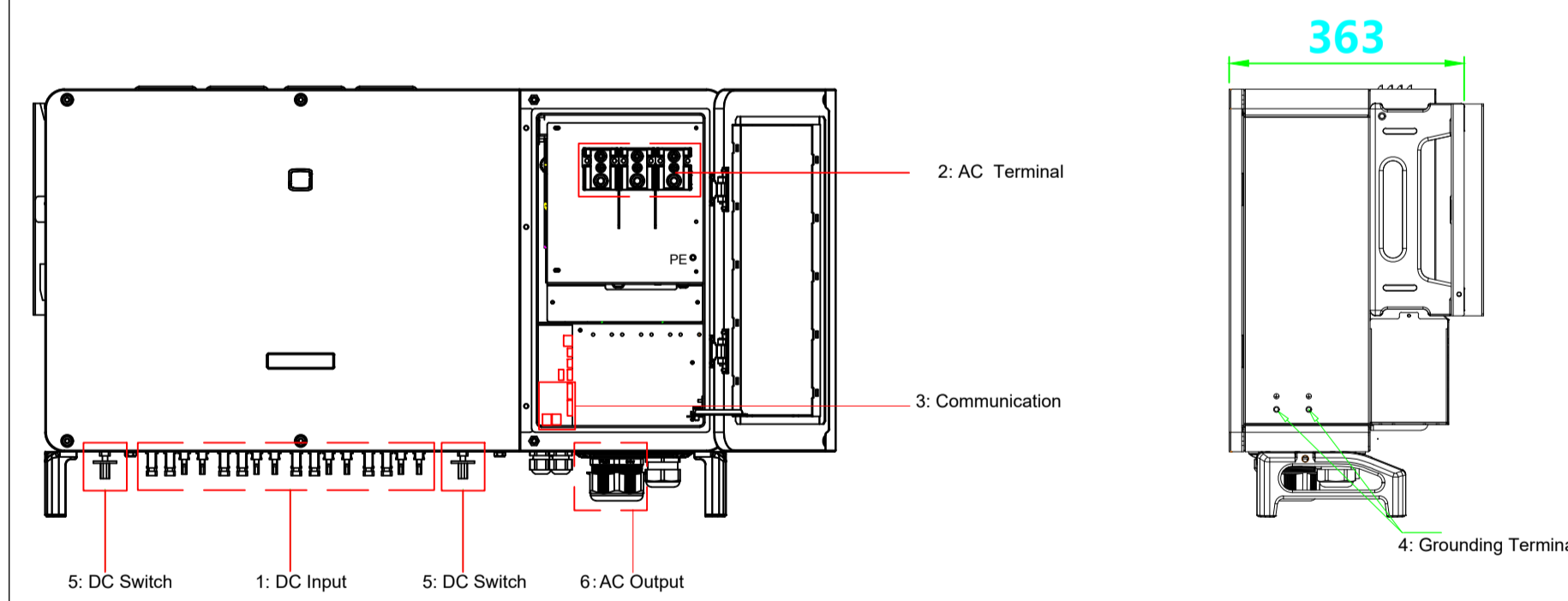

NO.	Name	Description	Terminal Type
1	DC Input	4 or 6 mm ²	MC4
2	AC Terminal	Range: 70-300mm ²	OT Terminal
3	Communication	RS485, 2x1mm ² Shielded Twisted Pair Cable	Tubular Terminal
4	Grounding Hole	M6, 16mm ² Yellow/Green Cable	OT Terminal
5	DC Switch	Load Break_ switch	---
6	AC Output	M75, Waterproof Terminal for AC Cable	---

IMPIANTO AGRIVOLTAICO DELLA POTENZA NOMINALE DI 40.683,52 kWp "SALICE SANCHIRICO"

UBICATO NEL COMUNE DI SALICE SALENTINO (LE)

CODICE IDENTIFICATIVO PRATICA AU REGIONALE: T141QE2

Titolo Elaborato:

PARTICOLARI COSTRUTTIVI INVERTER

IDENTIFICAZIONE ELABORATO (MITE)

LIVELLO PROGETTAZIONE	TIPO DOCUMENTO	CODICE IDENTIFICATIVO	DATA	SCALA
PD	D	T141QE2_TAV_08	LUGLIO 2022	-

REVISIONI

REV.	DATA	DESCRIZIONE	ESEGUITO	VERIFICATO	APPROVATO
00	07/22	Prima emissione	Ing. Cosimo Totaro	Ing. Cosimo Totaro	Ing. Cosimo Totaro

PROGETTAZIONE:



TECNICO:

Ing. Cosimo Totaro
Ordine degli Ingegneri
Provincia di Brindisi n.1718



PROPONENTE:

TRINA SOLAR PAPIRO S.R.L.
Piazza Borromeo, 14
20123, Milano (MI) - Italy

