



REGIONE PUGLIA



CITTA' DI BRINDISI

COSTRUZIONE ED ESERCIZIO DI UN IMPIANTO "AGROVOLTAICO" PER PRODUZIONE DI ENERGIA ELETTRICA DA FONTE FOTOVOLTAICA AVENTE POTENZA IN IMMISSIONE PARI A 27,308 MW
CON RELATIVO COLLEGAMENTO ALLA RETE ELETTRICA - IMPIANTO DENOMINATO "BRINDISI LOIZZO" UBICATO IN AGRO DEL COMUNE DI BRINDISI.

DATI CATASTALI: Brindisi Fg. 179 P.IIa 45,123,124,226,227,228,229,266, 86,130,131,215,230,231,232,233,234
Fg 186 P.IIa 210,217,218,224,237,472,508,690,545
Mesagne Fg. 103 P.IIa 60,61,58,57,56,46,83



Via Gen. Giacinto Antonelli n.3
70043 Monopoli (BA)



Ing. Emanuele Verdoscia
Via Villafranca n.42
73041 Carmiano (LE)



CABINA RICEZIONE ANELLO MT

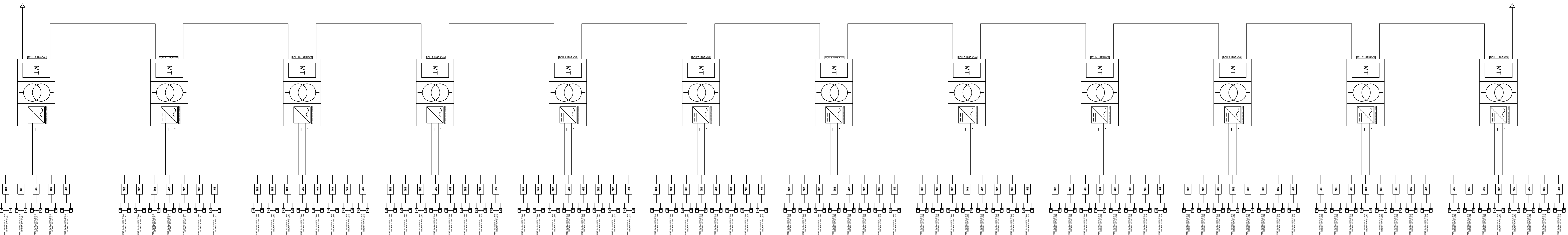

Elaborato	Tecnico
Schema elettrico unifilare	Ing. Emanuele Verdoscia