

TOMBINO SCATOLARE A SINGOLA CANNA – SEZIONE LONGITUDINALE TIPOLOGICA

Scala 1:50

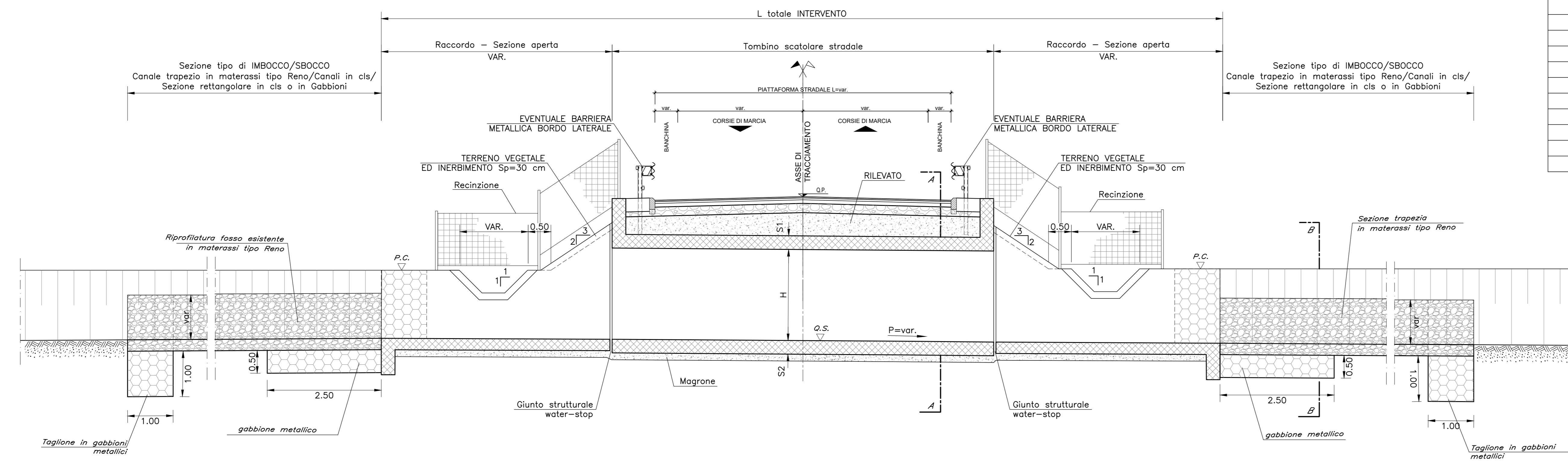

WBS tombino	WBS viabilità	Inlet elev (m s.m.m.)	Outlet elev (m s.m.m.)	B (m)	H (m)	Lunghezza	Tipologico	S1 (m)	S2 (m)	tipologico	Piano di rotolamento (m s.m.m.)	distanza Pstrada-estradosso soletta (m)
N001	NV01	62.83	62.71	2.0	2.5	13.5	T52	0.3	0.4	2x2,5	66.49	0.92
N003	NV04_ex	108.39	108.3	3.0	2.0	13.0	T54	0.4	0.5	3x2	111.59	0.84
N004	NV04_dx	107.85	107.83	2.0	2.0	15.0	T51	0.3	0.4	2x2	111.59	1.05
N006	NV04	102.4	102.2	2.0	2.0	13.0	T51	0.3	0.4	2x2	106.29	1.69
N015	NV09	54.86	54.67	7.0	4.0	18.0	T55	0.8	0.9	7x4	60.82	1.26
N009	NV17	179.47	179.34	2.0	2.0	9.5	T51	0.3	0.4	2x2	182.94	1.24
N009a	NV17	180.4	180.26	3.0	2.0	11.0	T54	0.4	0.5	3x2	185.46	2.73
N10A	NV20A	222.5	222.3	2.0	3.0	9.5	T53	0.3	0.4	2x3	226.33	0.63
N10	NV20	215.5	215.3	2.0	3.0	12.0	T53	0.3	0.4	2x3	220.03	1.33
N13	NV25	175.9	175.8	2.0	2.0	19.5	T51	0.3	0.4	2x2	178.72	0.57
N14	Accesso PT23	170.2	170	2.0	2.0	30.5	T51	0.3	0.4	2x2	173.02	0.62

TOMBINO SCATOLARE A SINGOLA CANNA – PIANTA TIPOLOGICA

Scala 1:50

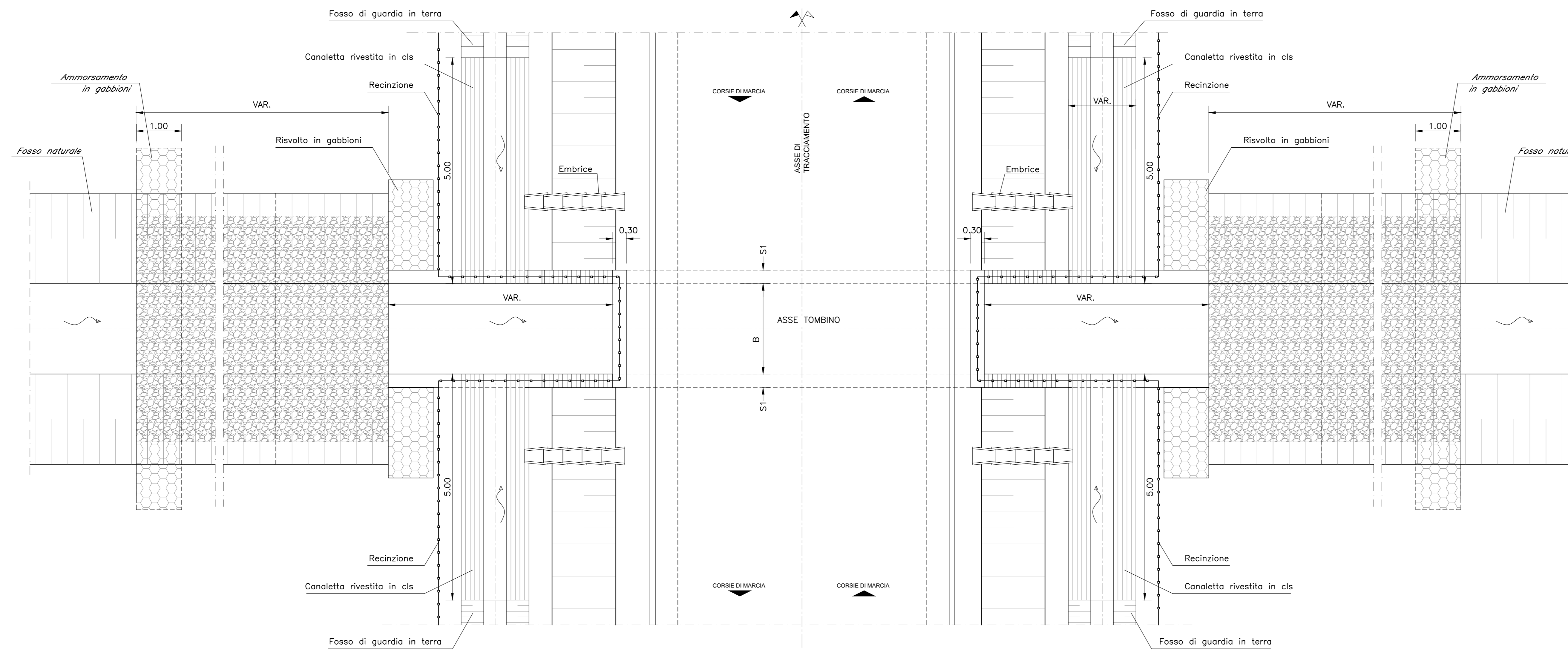

SEZIONE A-A

Scala 1:50

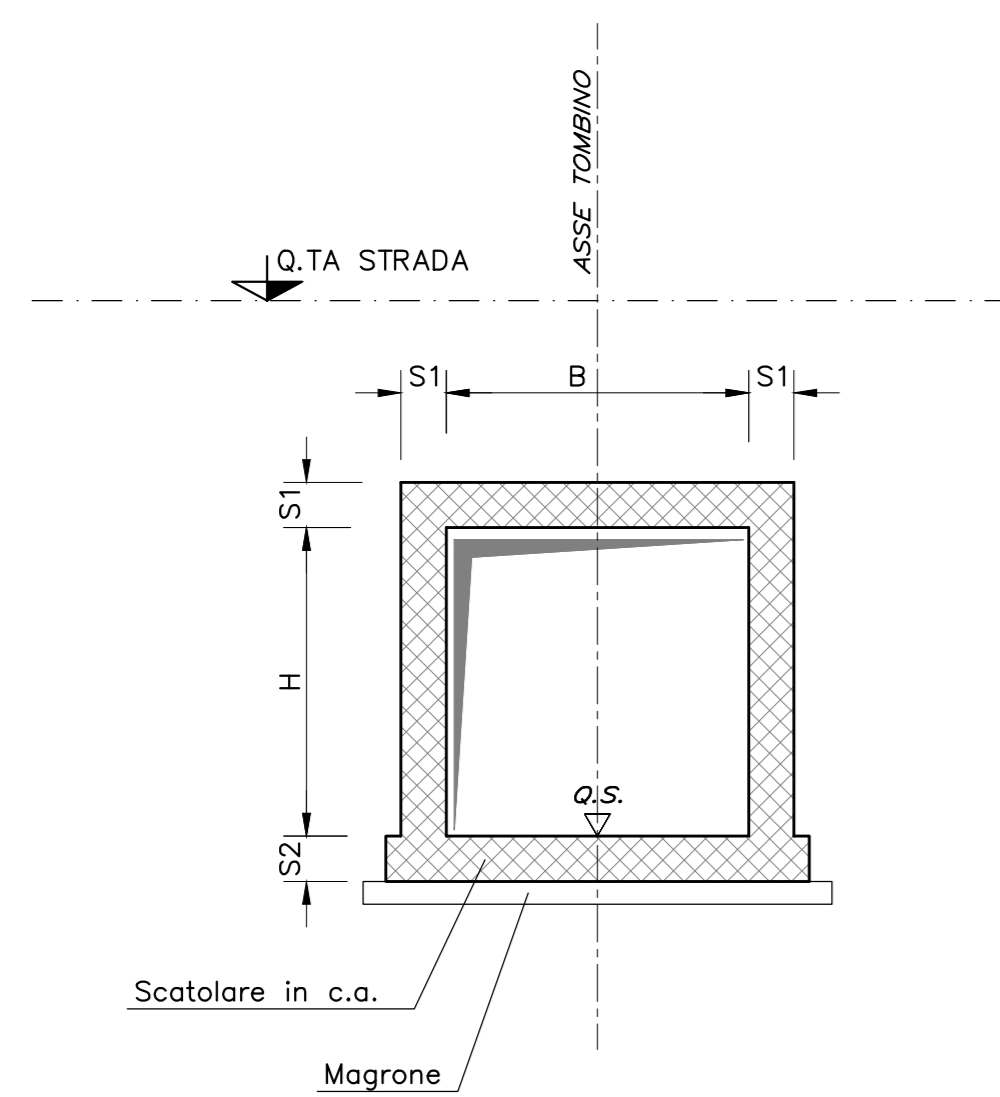

SEZIONE/PROSPETTO B-B

Scala 1:50

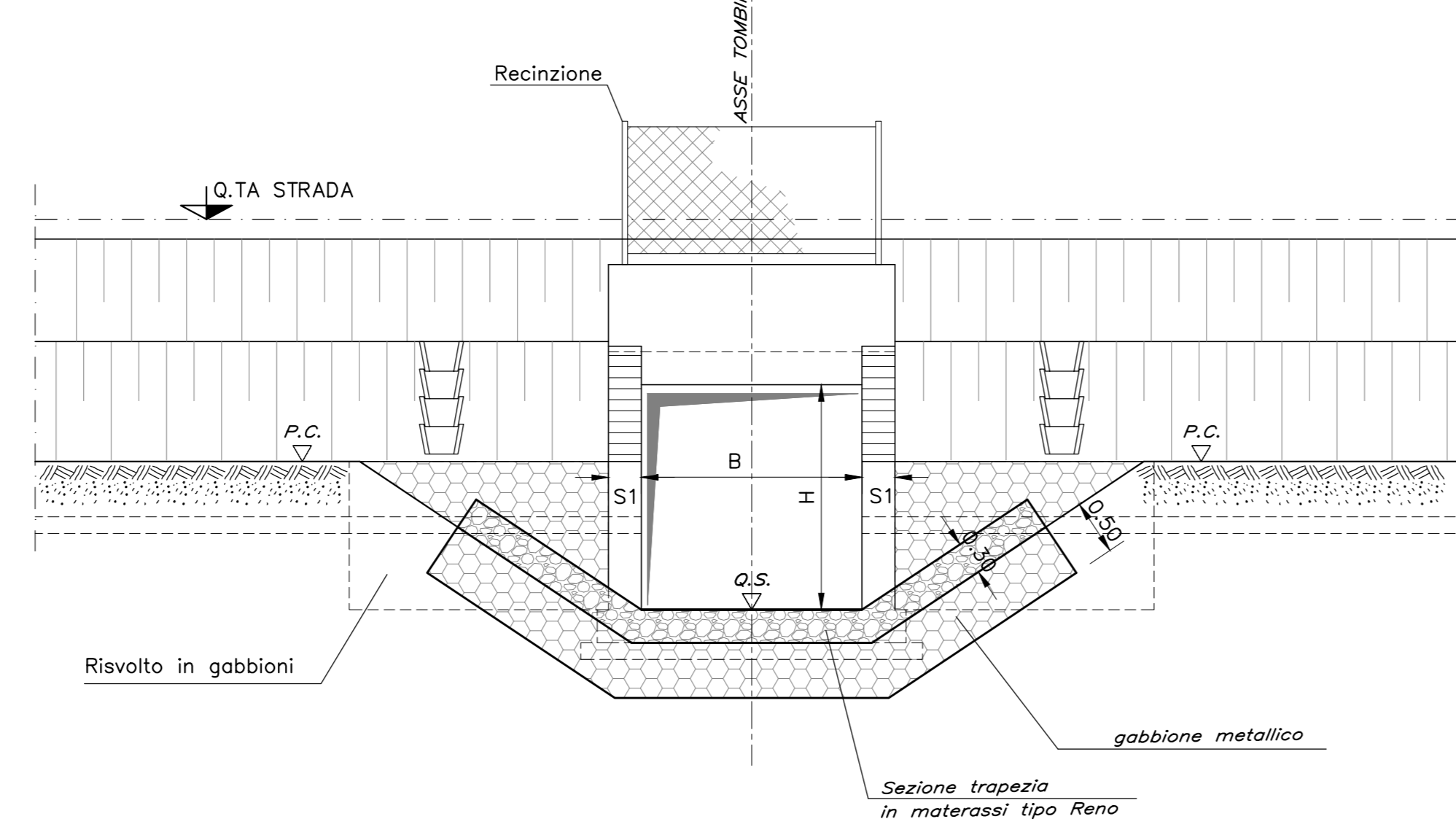

COMMITTENTE: 
 PROGETTAZIONE: 

S.O. PROGETTAZIONE INTEGRATA SUD
PROGETTO DI FATTIBILITA' TECNICA ED ECONOMICA
NUOVA LINEA AV SALERNO – REGGIO CALABRIA
LOTTO 1 BATTIPAGLIA – PRAIA
LOTTO 1A BATTIPAGLIA-ROMAGNANO E INTERCONNESSIONE CON LA
LS BATTIPAGLIA-POTENZA
TOMBINI STRADALI

Tipologico - Pianta, prospetto e sezioni

SCALA: **Varie**

Rev.	Descrizione	Redatto	Data	Verificato	Data	Approvato	Data	Autorizzato	Data
A	Emissione esecutiva	E. Seleni	20/07/2022	A. Giannone	20/07/2022	L. Zappalà	20/07/2022	F. Savin	20/07/2022

File: RC21 A 1 R 78 FZ N.00.0.0.001 A n. Elab.: