

CABINA RICEZIONE ANELLO MT

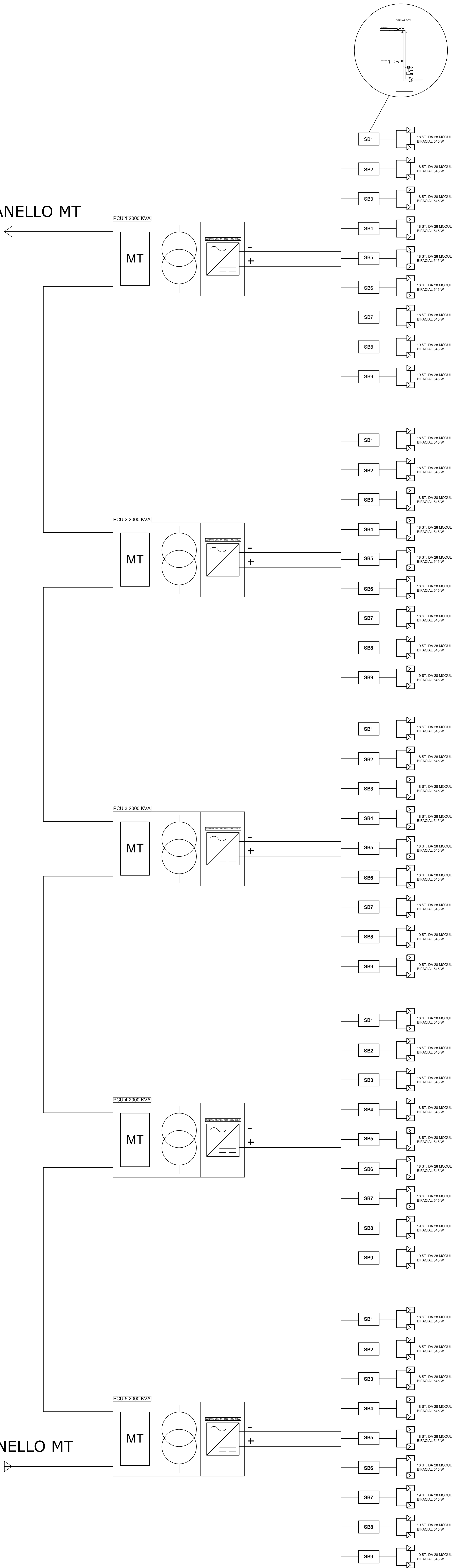

id PCU	id STRING BOX	N. STRINGHE	MODULI PER STRINGA	MODULI TOTALI	POTENZA TOTALE KW
1	1_1	18	28	504	274,68
1	1_2	18	28	504	274,68
1	1_3	18	28	504	274,68
1	1_4	18	28	504	274,68
1	1_5	18	28	504	274,68
1	1_6	18	28	504	274,68
1	1_7	18	28	504	274,68
1	1_8	19	28	532	289,94
1	1_9	19	28	532	289,94
2	2_1	18	28	504	274,68
2	2_2	18	28	504	274,68
2	2_3	18	28	504	274,68
2	2_4	18	28	504	274,68
2	2_5	18	28	504	274,68
2	2_6	18	28	504	274,68
2	2_7	18	28	504	274,68
2	2_8	19	28	532	289,94
2	2_9	19	28	532	289,94
3	3_1	18	28	504	274,68
3	3_2	18	28	504	274,68
3	3_3	18	28	504	274,68
3	3_4	18	28	504	274,68
3	3_5	18	28	504	274,68
3	3_6	18	28	504	274,68
3	3_7	18	28	504	274,68
3	3_8	19	28	532	289,94
3	3_9	19	28	532	289,94
4	4_1	18	28	504	274,68
4	4_2	18	28	504	274,68
4	4_3	18	28	504	274,68
4	4_4	18	28	504	274,68
4	4_5	18	28	504	274,68
4	4_6	18	28	504	274,68
4	4_7	18	28	504	274,68
4	4_8	19	28	532	289,94
4	4_9	19	28	532	289,94
5	5_1	18	28	504	274,68
5	5_2	18	28	504	274,68
5	5_3	18	28	504	274,68
5	5_4	18	28	504	274,68
5	5_5	18	28	504	274,68
5	5_6	18	28	504	274,68
5	5_7	19	28	532	289,94
5	5_8	19	28	532	289,94
5	5_9	19	28	532	289,94
				22988	12528,46

CABINA RICEZIONE ANELLO MT



REGIONE PUGLIA



CITTA' DI BRINDISI

COSTRUZIONE ED ESERCIZIO DI UN IMPIANTO "AGROVOLTAICO" PER PRODUZIONE DI ENERGIA ELETTRICA DA FONTE FOTOVOLTAICA AVENTE POTENZA IN IMMISSIONE PARI A 12.5 MWe POTENZA MODULI PARI A 12,52 MWp CON RELATIVO COLLEGAMENTO ALLA RETE ELETTRICA - IMPIANTO DENOMINATO "BRINDISI TORMARESCA" UBICATO IN AGRO DEL COMUNE DI BRINDISI.



progettato e sviluppato da
Via Gen. Giacinto Antonelli n.3
70043 Monopoli (BA)



Ing. Emanuele Verdoscia
Via Villafranca n.42
73041 Carmiano (LE)



Elaborato	Tecnico
Schema unifilare di impianto	Ing. Emanuele Verdoscia