

COMUNI DI:
TRAMATZA, SIAMAGGIORE,
SOLARUSSA

PROVINCIA: ORISTANO
REGIONE: SARDEGNA

"FATTORIA SOLARE TRAMATZA"
AGRIVOLTAICO DI TIPO ELEVATO E AVANZATO

PROGETTO DEFINITIVO

SCHEDA TECNICA INVERTER

Tipo Elaborato	Codice Elaborato	Data	Scala CAD	Formato	Foglio / di	Scala
TAV.	2104_T.P.27	21/04/2023	-	A4	1/3	-

PROPONENTE

EF AGRI Società Agricola A R.L.
Via del Brennero, 111
38121 - Trento (TN)

SVILUPPO



SET SVILUPPO s.r.l.
Corso Trieste, 19
00198 - Roma (RM)

PROGETTAZIONE

Ing. Giacomo Greco



Ing. Marco Marsico



Rev.	Data	Descrizione	Redatto	Verificato	Approvato
00	21/04/2023	Prima Emissione	Ing. M. Marsico	Ing. G. Greco	Ing. M. Marsico

SUN2000-185KTL-H1

Smart String Inverter



9
MPP Trackers



99.0%
Max. Efficiency



String-level
Management



Smart I-V Curve
Diagnosis Supported



MBUS
Supported



Fuse Free
Design



Surge Arresters for
DC & AC



IP66
Protection

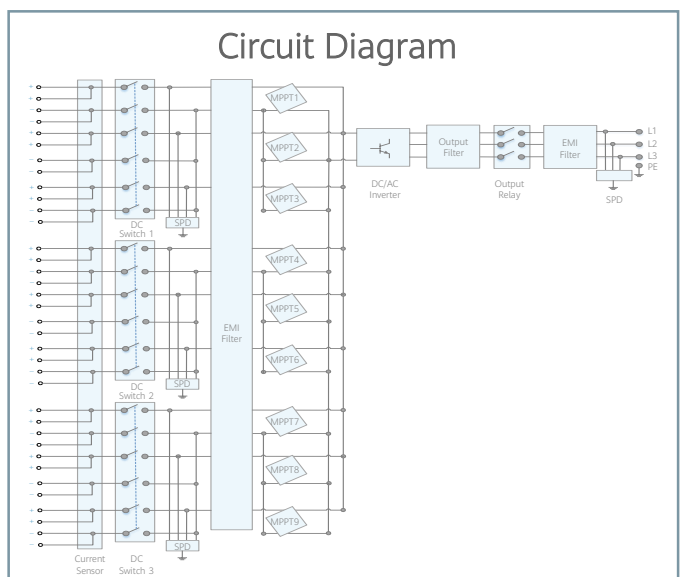
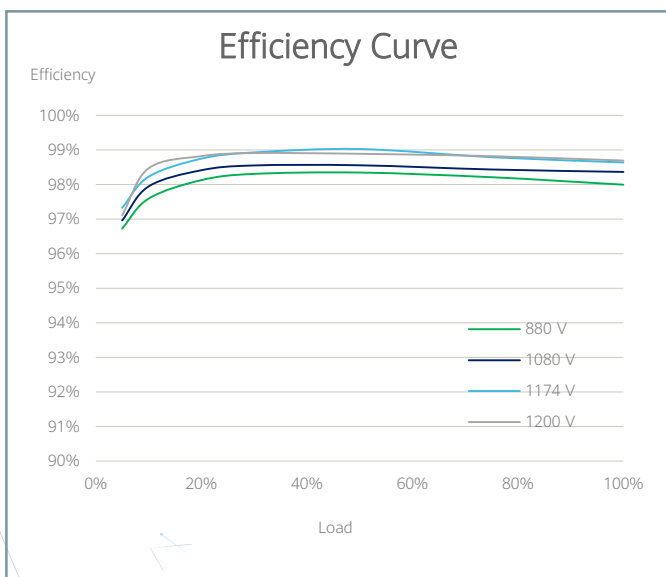

Technical Specifications

Efficiency	
Max. Efficiency	99.03%
European Efficiency	98.69%
Input	
Max. Input Voltage	1,500 V
Max. Current per MPPT	26 A
Max. Short Circuit Current per MPPT	40 A
Start Voltage	550 V
MPPT Operating Voltage Range	500 V ~ 1,500 V
Nominal Input Voltage	1,080 V
Number of Inputs	18
Number of MPP Trackers	9
Output	
Nominal AC Active Power	175,000 W @40°C
Max. AC Apparent Power	185,000 VA
Nominal Output Voltage	800 V, 3W + PE
Rated AC Grid Frequency	50 Hz / 60 Hz
Nominal Output Current	126.3 A @40°C
Max. Output Current	134.9 A
Adjustable Power Factor Range	0.8 LG ... 0.8 LD
Max. Total Harmonic Distortion	< 3%
Protection	
Input-side Disconnection Device	Yes
Anti-islanding Protection	Yes
AC Overcurrent Protection	Yes
DC Reverse-polarity Protection	Yes
PV-array String Fault Monitoring	Yes
DC Surge Arrester	Type II
AC Surge Arrester	Type II
DC Insulation Resistance Detection	Yes
Residual Current Monitoring Unit	Yes
Communication	
Display	LED Indicators, Bluetooth/WLAN + APP
USB	Yes
MBUS	Yes
RS485	Yes
General	
Dimensions (W x H x D)	1,035 x 700 x 365 mm (40.7 x 27.6 x 14.4 inch)
Weight (with mounting plate)	84 kg (185.2 lb.)
Operating Temperature Range	-25°C ~ 60°C (-13°F ~ 140°F)
Cooling Method	Smart Air Cooling
Max. Operating Altitude without Derating	4,000 m (13,123 ft.)
Relative Humidity	0 ~ 100%
DC Connector	Staubli MC4 EVO2
AC Connector	Waterproof Connector + OT/DT Terminal
Protection Degree	IP66
Topology	Transformerless
Standard Compliance (more available upon request)	
Certificates	EN 62109-1/-2, IEC 62109-1/-2, EN 50530, IEC 62116, IEC 60068, IEC 61683, IEC 61727, IEC 62910, P.O. 12.3, RD 1699, RD 661, RD 413, RD 1565, RD 1663, ABNT NBR 16149, ABNT NBR 16150, ABNT NBR IEC 62116