



PROGETTO DEFINITIVO DI UN IMPIANTO AGRO-FOTOVOLTAICO DELLA POTENZA COMPLESSIVA DI 57 MW_p, E RELATIVE OPERE DI CONNESSIONE ALLA RETE, CON SISTEMA DI ACCUMULO DI CAPACITA' PARI 10 MWh DA REALIZZARSI NEL COMUNE DI ROTELLO E MONTELONGO (CB)

PROGETTO DEFINITIVO

COMMITTENTE: ROTELLO SOLAR s.r.l.

PROGETTISTA:

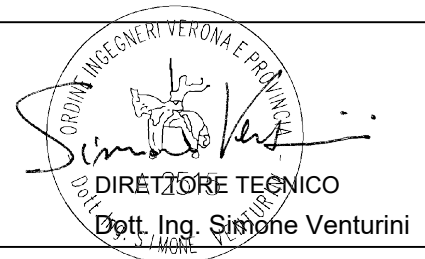

TITOLO ELABORATO:

**BROCHURE CABINE MT/BT DI CAMPO
PREFABBRICATE IN CONTAINER**

ELABORATO n° :

BI026F-D-RO00-IMP-SH-04-00

NOME FILE :

SCALA : -

DATA : Dicembre 2022

REVISIONE	N.	DATA	DESCRIZIONE	ELABORATO	CONTROLLATO	APPROVATO
	00	Dicembre 2022	Emissione	N.Ostoich	M.Palvarini	S. Venturini
	01					
	02					
	03					
	04					

MVS3200/4480-LV

MV Turnkey Solution for 1500 Vdc String Inverter SG350HX

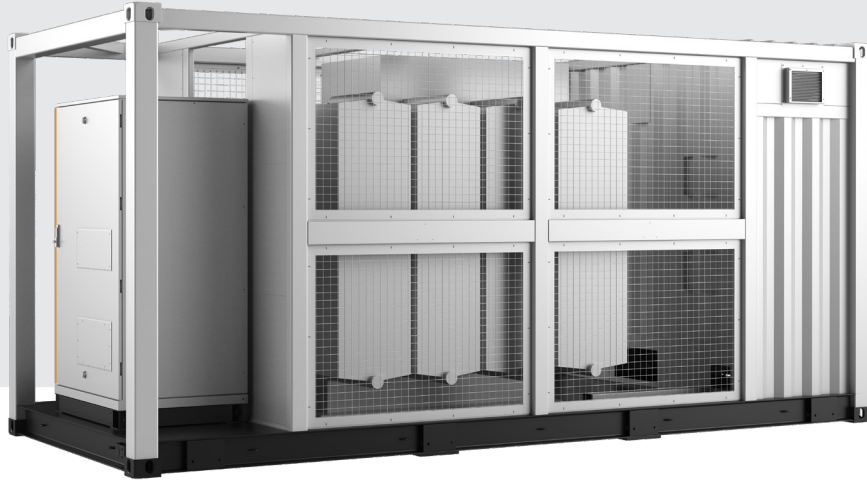

SAVED INVESTMENT

- Up to 4.48 MW block design
- Easy transportation due to standard container design
- All pre-assembled for easy set-up and commissioning



SAFETY

- MV and LV isolated, independent control room
- All key components front accessible, no need walk-in operation



EASY O&M

- Online analysis for fast trouble shooting
- Modular design, main device easy replacement



RELIABLE

- All components type-tested
- Compliance with standards: IEC 60076, IEC 62271, IEC 61439

CIRCUIT DIAGRAM

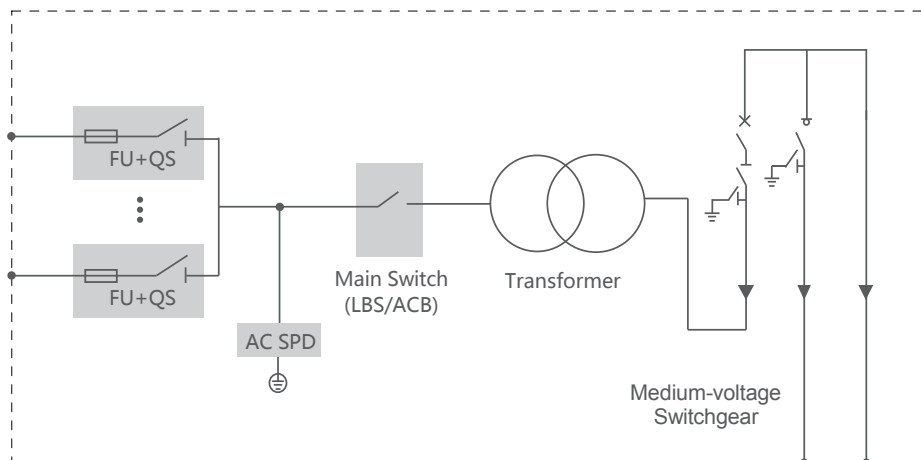

Type designation	MVS3200-LV	MVS4480-LV
Transformer		
Transformer type	Oil immersed	
Rated power	3200 kVA @ 40 °C	4480 kVA @ 40 °C
Max. power	3520 kVA @ 30 °C	4928 kVA @ 30 °C
Vector group	Dy11	
LV / MV voltage	0.8 kV / 20 – 35 kV	
Maximum input current at nominal voltage	2540 A	3557 A
Frequency	50 Hz / 60 Hz	
Tapping on HV	0, ±2×2.5%	
Efficiency	≥99%	
Cooling type	ONAN (Oil Natural Air Natural)	
Impedance	7% (±10%)	8% (±10%)
Oil type	Mineral oil (PCB free)	
Winding material	Al / Al	
Insulation class	A	
MV Switchgear		
Insulation type	SF6	
Rate voltage	24 – 36 kV	
Rate current	630 A	
Internal arcing fault	IAC AFL 20kA/1s	
Qty. of feeder	3 feeders	
LV Panel		
Main switch specification	4000 A / 800 Vac / 3P, 1 pcs	
Disconnecter specification	260 A / 800 Vac / 3P, 10 pcs	260 A / 800 Vac / 3P, 14 pcs
Fuse specification	400A / 800 Vac / 1P, 30 pcs	400 A / 800 Vac / 1P, 42 pcs
Protection		
AC input protection	FUSE+Disconnecter	
Transformer protection	Oil-temperature, oil-level, oil-pressure	
Relay protection	50/51,50N/51N	
LV overvoltage protection	AC Type II (optional: AC Type I + II)	
General Data		
Dimensions(W*H*D)	6058*2896*2438 mm	
Approximate weight	15 T	17 T
Operating ambient temperature range	-20 to 60 °C (optional: -30 to 60 °C)	
Auxiliary power supply	5 kVA / 400 V (optional: max. 40 kVA)	
Degree of protection	IP54	
Allowable relative humidity range (non-condensing)	0 – 95 %	
Operating altitude	1000 m (standard) / > 1000 m (optional)	
Communication	Standard: RS485, Ethernet; Optional: optical fiber	
Compliance	IEC 60076, IEC 62271-200, IEC 62271-202, IEC 61439-1, EN50588-1	

MVS6400-LV

MV Turnkey Solution for 1500 Vdc String Inverter SG350HX



SAVED INVESTMENT

- Up to 7 MW block design
- Easy transportation due to standard container design
- All pre-assembled for easy set-up and commissioning



SAFETY

- MV and LV isolated, independent control room
- All key components front accessible, no need walk-in operation



EASY O&M

- Online analysis for fast trouble shooting
- Modular design, main device easy replacement



RELIABLE

- All components type-tested
- Compliance with standards: IEC 60076, IEC 62271, IEC 61439

CIRCUIT DIAGRAM

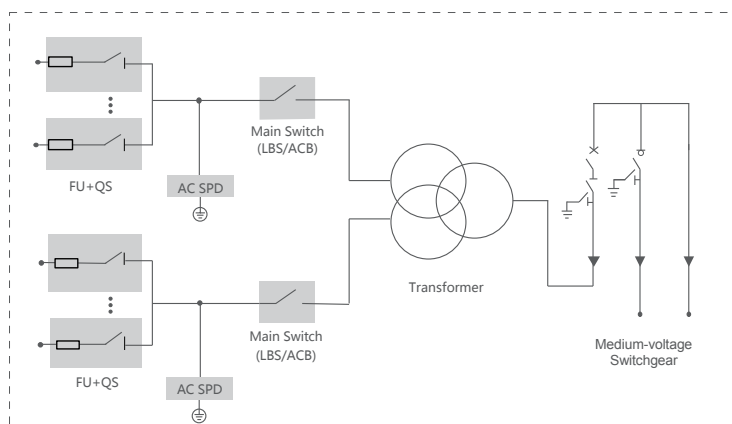

Type designation	MVS6400-LV
Transformer	
Transformer type	Oil immersed
Rated power	6400 kVA @ 40 °C
Max. power	7040 kVA @ 30 °C
Vector group	Dy11y11
LV / MV voltage	0.8 - 0.8 kV / 10 – 35 kV
Maximum input current at nominal voltage	2540 A * 2
Frequency	50 Hz / 60 Hz
Tapping on HV	0, ±2*2.5%
Efficiency	≥99%
Cooling type	ONAN (Oil Natural Air Natural)
Impedance	8% (±10%)
Oil type	Mineral oil (PCB free)
Winding material	Al (Option:Cu)
Insulation class	A
MV Switchgear	
Insulation type	SF6
Rate voltage	24 – 36 kV
Rate current	630 A
Internal arcing fault	IAC AFL 20kA/1s
Qty. of feeder	3 feeders
LV Panel	
Main switch specification	4000 A / 800 Vac / 3P, 2 pcs
Disconnecter specification	260 A / 800 Vac / 3P, 20 pcs
Fuse specification	400A / 800 Vac / 1P, 60 pcs
Protection	
AC input protection	FUSE+Disconnecter
Transformer protection	Oil-temperature, oil-level, oil-pressure
Relay protection	50/51, 50N/51N
LV overvoltage protection	AC Type II (optional: AC Type I + II)
General Data	
Dimensions (W*H*D)	6058*2896*2438 mm
Approximate weight	22 T
Operating ambient temperature range	-30 to 60 °C
Auxiliary power supply	5 kVA / 400 V (optional: max. 40 kVA)
Degree of protection	IP54
Allowable relative humidity range (non-condensing)	0 – 95 %
Operating altitude	1000 m (standard) / > 1000 m (optional)
Communication	Standard: RS485, Ethernet; Optional: optical fiber
Compliance	IEC 60076, IEC 62271-200, IEC 62271-202, IEC 61439-1, EN50588-1