



PROGETTO DEFINITIVO DI UN IMPIANTO AGRO-FOTOVOLTAICO DELLA POTENZA COMPLESSIVA DI 57 MW<sub>p</sub>, E RELATIVE OPERE DI CONNESSIONE ALLA RETE, CON SISTEMA DI ACCUMULO DI CAPACITA' PARI 10 MWh DA REALIZZARSI NEL COMUNE DI ROTELLO E MONTELONGO (CB)

## PROGETTO DEFINITIVO

COMMITTENTE: ROTELLO SOLAR s.r.l.

PROGETTISTA:



TITOLO ELABORATO:

**BROCHURE SEZIONATORE AT**

ELABORATO n° :

BI026F-D-RO00-IMP-SH-08-00

NOME FILE :

SCALA : -

DATA : Dicembre 2022

REVISIONE	N.	DATA	DESCRIZIONE	ELABORATO	CONTROLLATO	APPROVATO
	00	Dicembre 2022	Emissione	N.Ostoich	M.Palvarini	S. Venturini
	01					
	02					
	03					
	04					

**TCB 72.5-300 kV Double-break disconnecter**

**HV Switching**



## We know how

Our range of double-break disconnectors is designed to ensure the best performances and reliability, which are the result of our 60-year old experience.

Over 100,000 disconnectors installed in more than 100 countries worldwide are the guarantee of best-buys.

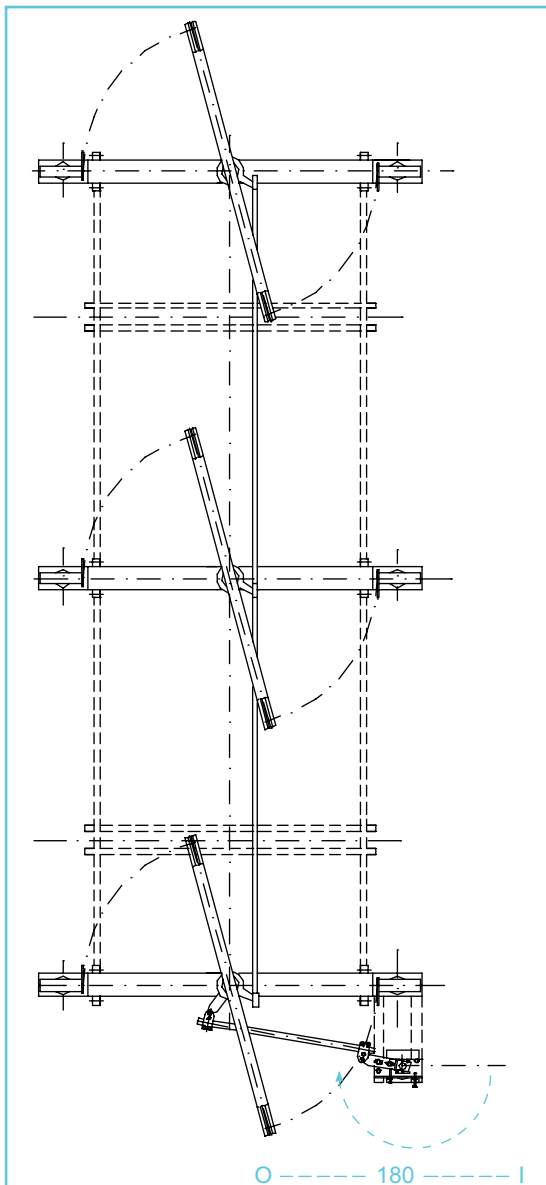

## The TCB double-break disconnector

The TCB double-break disconnector is formed by three poles, operated simultaneously either by a single operating mechanism and mechanical linkages between the poles or by one mechanism for each pole.

The main characteristics of the TCB disconnector are a reduced phase to phase distance, and a very high capability to withstand terminal loads. At the design stage of the bay, the first feature allows space to be saved and the second one, due to insulators directly bolted on the base frame helps to avoid additional post insulators. The insulating columns used for the TCB can comply with either IEC or ANSI standard. Special heights and creepage distances are also available on request.

The electrodynamic behaviour is also improved by the symmetrical design of the motion: during a short-circuit, the efforts on both sides of the pivot point tend to be balanced, preventing any tendency for the main contacts to open.

To adapt to various layouts of substations, the poles can be erected traditionally (horizontal) or wall-mounted, and even upside down.

Like all our models, the TCB meets the latest international standards (IEC, ANSI) but can also be customised according to particular specification.

## Earthing switch

Integrated earthing switches are available for mounting at each or both sides of the pole, with the same short-time current withstand capability.

The earthing switch is actuated by the same types of operating mechanisms as the disconnector, either manually or electrically, single-pole or 3-pole operation. It can be electrically and/or mechanically interlocked with the main blade.

## Construction features

The arm is made of rectangular drawn aluminium tubes, with silver plated copper fingers (thickness accorded to rated current). The contact pressure is ensured by stainless steel springs. All the hardware of the live part is made of stainless steel.

The male (fixed) contacts are also silver plated and protected from corona effects by suitable corona shields, according to rated voltage. They are bolted directly on the top of the insulator.

The base frame and the rotary support are made of hot-dip galvanised steel profiles. The bearings are sealed and greased for a lifetime of maintenance free operation.

All our design and manufacturing process is ruled by ISO 9001 certified procedures to guarantee a perfect repetitivity of the performances from the type-testing to the delivery of series.



## Operating principle

The base frame supports two insulators and a rotating insulating rod (drive insulator), which supports and operates the arm.

The live part is very simple in its design and motion. From the open position, the arm ① rotates to enter directly the fixed contacts ② at the ends of the disconnector. There are a minimum of parts in motion, and no rotary contact is necessary.

The flat HV terminals ③ are as per the next page figure. Custom terminals are also available upon request.

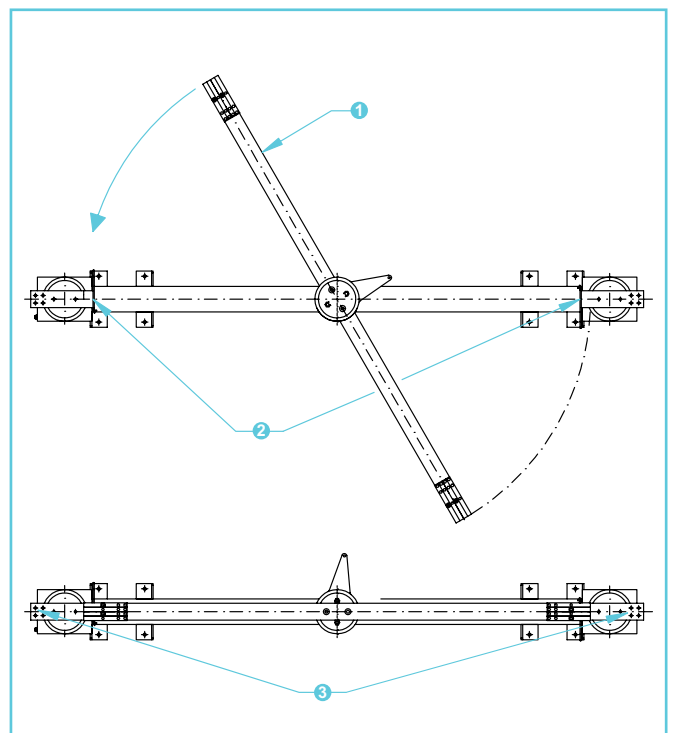

## Ratings and dimensions

The values in the table refer to IEC standards, unless explicit reference to ANSI is made; for missing ANSI ratings, refer to C37.32

Rated voltage	$U_r$ (kV)	72.5	123	145	170	245	300	
Rated power-frequency withstand voltage	TE $U_d$ (kV)	140	230	275	325	395	460	380
	AID $U_d$ (kV)	160	265	315	375	460	530	435
Rated lightning impulse withstand voltage	TE $U_p$ (kV <sub>p</sub> )	325 (IEC) 350 (ANSI)	550	650	750	950 (IEC) 900 (ANSI)	1050	1050
	AID $U_p$ (kV <sub>p</sub> )	375	630	750	860	1050	1200	1050 (+170)
Rated switching impulse withstand voltage	TE $U_s$ (kV <sub>p</sub> )	-	-	-	-	-	-	850
	AID $U_s$ (kV <sub>p</sub> )	-	-	-	-	-	-	700 (+245)

TE: To Earth

AID: Across the Isolating Distance

Rated continuous current	$I_r$ (A)	up to 4000 IEC / ANSI (depending on rated voltage)
Rated short-time withstand current	$I_k$ (kA)	up to 75 / 3s (depending on rated current)
Rated peak withstand current	$I_p$ (kA <sub>p</sub> )	up to 190 (depending on rated current)

Dimensions (mm)	A	1280	1780	2200	2200	2880	3200	3200
B	IEC	770	1220	1500	1700	2100	2300	2300
	ANSI	762	1143	1372	1575	2032	2337	2337
C	IEC	970	1420	1720	1920	2370	2570	2570
	ANSI	962	1343	15912	1795	2302	2607	2607
D		900	1400	1800	1800	2300	2800	2800
E		170	170	270	270	270	270	270
F		-	-	-	-	-	270	270
G		4 $\phi$ 18	4 $\phi$ 18	4 $\phi$ 18	4 $\phi$ 18	4 $\phi$ 18	8 $\phi$ 18	8 $\phi$ 18

## Reliability and maintenance

Due to lifetime greased or self-lubricated hinges, and self-wiping contact, the maintenance of the TCB metallic parts is ensured by its own motion. The use of corrosion-free or protected materials for all the components induces an exceptional reliability over many years of service. The mechanical endurance performance exceeds the IEC standard.

## Optional devices

Upon request, the disconnector can be equipped with a bus-transfer current switching device, according to IEC 62271-102 (annex B).

The integrated earthing switch can also be fitted with an optional induced currents switching device, as per IEC 62271-102 (annex C).

For operation under severe ice conditions (up to 20 mm), ice shields are available to protect the parts, where needed.

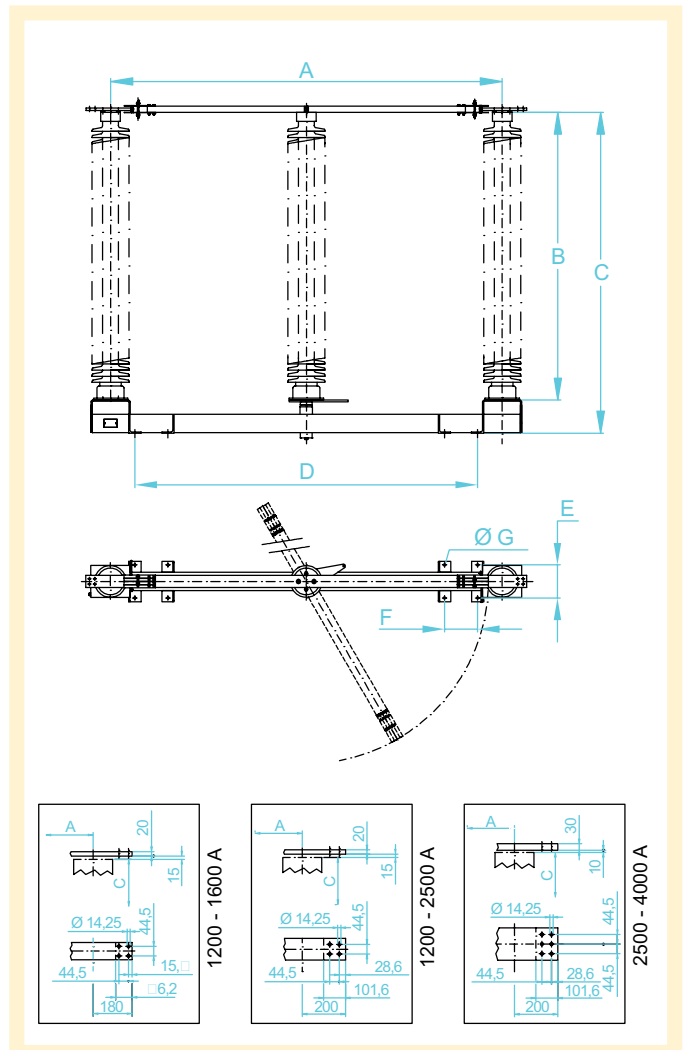

### COELME

Via G. Galilei, 1/2 - 30036 Santa Maria di Sala (VE) - Italia  
Tel.: +39 041 486022 - Fax: +39 041 486909  
E-Mail: contact@coelme-egic.com, www.coelme-egic.com

### EGIC

60b, rue L. et R. Desgrand - 69625 Villeurbanne CEDEX - France  
Tel.: +33 4 72 66 20 70 - Fax: +33 4 72 39 08 65  
E-Mail: contact@coelme-egic.com, www.coelme-egic.com