

REGIONE SARDEGNA
Provincia del Sud Sardegna

**IMPIANTO EOLICO NEL COMUNE DI
VILLAMASSARGIA**

**POTENZA MASSIMA IN IMMISSIONE DI 59,15 MW
COMPRENSIVA DI SISTEMA DI ACCUMULO INTEGRATO DA 15,75 MW**

Oggetto	PROGETTO DEFINITIVO	SR-VI-TC11	
Titolo	SEZIONI TRASVERSALI RAPPRESENTATIVE VIABILITÀ DI IMPIANTO	Cod.elab.	
		scala	1:200

Data	Rev.	Descrizione	Eseg.	Contr.	Appr.
Marzo 2023	0	Emissione per procedura di VIA	MU	GF	SR

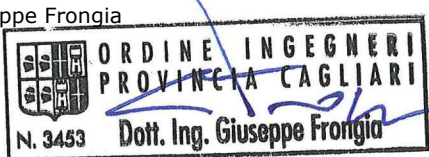
<p>A cura di: I.A.T. Consulenza e progetti S.r.l. Dott. Ing. Giuseppe Frongia</p> <p>Gruppo di progettazione: Ing. Giuseppe Frongia (coordinatore e responsabile) Ing. Marianna Barbarino Ing. Enrica Batzella Pian. Terr. Andrea Cappai Ing. Gianfranco Corda Ing. Paolo Desogus Pian. Terr. Veronica Fais Ing. Gianluca Melis Ing. Andrea Onnis Pian. Terr. Eleonora Re Ing. Elisa Roych Ing. Marco Utzeri</p> <p>Contributi specialistici: Ce.Pi.Sar. (Chiroterofauna) Ing. Antonio Dedoni (acustica) Dott. Geol. Maria Francesca Lobina (geologia) Agr. Dott. Nat. Nicola Manis (pedologia) Dott. Nat. Francesco Mascia (Flora) Dott. Maurizio Medda (Fauna) Dott.ssa Alice Nozza (Archeologia) Dott. Matteo Tatti (Archeologia)</p>	<p>Progettazione: Dott. Ing. Giuseppe Frongia</p> <div style="border: 1px solid black; padding: 5px; text-align: center;"></div>
<p>Il Committente:</p>	

 iat CONSULENZA E PROGETTI www.iatprogetti.it	 	SORGENIA RENEWABLES S.R.L. Via Algardi, 4 20148 Milano (MI)	
---	---	--	---

A4	SR-VI-TC11_Sezioni trasversali rappresentative viabilità di impianto	SR-VI-TC11_Sezioni trasversali rappresentative viabilità di impianto	2022/0301b
Formato	File origine	File di stampa	Codice pratica

Elaborazioni: I.A.T. Consulenza e progetti S.r.l. con socio unico - Via Michele Giua s.n.c. ZI CACIP , 09122 Cagliari, Tel./Fax +39.070.658297

Disegni, calcoli, specifiche e tutte le altre informazioni contenute nel presente documento sono di proprietà della I.A.T. Consulenza e progetti s.r.l. Al ricevimento di questo documento la stessa diffida pertanto di riprodurlo, in tutto o in parte, e di rivelarne il contenuto in assenza di esplicita autorizzazione.

SEZIONI TRASVERSALI
Profilo longitudinale tratto 1-2
Viabilità di impianto - Postazione aerogeneratore
VI01

Nota: Le canalette di deflusso delle acque meteoriche, non indicate nel presente elaborato, sono rappresentate graficamente nelle sezioni stradali tipo dell'elaborato "SR-VI-TC12_Piazzole aerogeneratori e strade di servizio - Particolari costruttivi", individuate planimetricamente nell'elaborato "SR-VI-TC13_Opere di regimazione acque superficiali - Planimetria generale" e quantificate nell'elaborato "SR-VI-RC6_Computo Metrico Estimativo opere civili".

DISEGNI DI RIFERIMENTO

TAVOLA	DESCRIZIONE
SR-VI-TC8.1	Piazzole e viabilità - Planimetria di progetto - Fase di cantiere
SR-VI-TC10	Profili longitudinali viabilità di impianto
SR-VI-TC12	Piazzole aerogeneratori e strade di servizio - Particolari costruttivi
SR-VI-TC13	Opere di regimazione acque superficiali - Planimetria generale

Sezione: 3
 Progressiva: 30.000
 Q. Progetto: 194.370

192.00

Quote Terreno	-194.37		194.47		194.54		-194.57
Quote Progetto		194.41	193.91	193.97	194.03	194.53	
Parziali			2.50		2.50		
Progressiva		-2.61	-2.50	0.00	2.50	2.60	
Dislivelli		0.00	-0.11	-0.50	-0.50	0.00	

Sezione: 4
 Progressiva: 40.000
 Q. Progetto: 195.028

193.00

Quote Terreno	-194.89		195.03		195.05		-195.92
Quote Progetto		194.57	194.63	194.69	195.57		
Parziali			2.50		2.50	0.48	
Progressiva		-2.51	0.00	2.50	2.98		
Dislivelli		0.00	-0.42	-0.80	-0.00		

Sezione: 5
 Progressiva: 44.781
 Q. Progetto: 195.396

193.00

Quote Terreno	-195.07			195.26	-195.33	195.44	-195.94
Quote Progetto		195.15	194.93	195.00	195.06	195.42	
Parziali			2.50		2.50		
Progressiva		-2.68	-2.30	0.00	2.50	2.54	
Dislivelli		0.00	0.18	-0.26	-0.36	0.00	

Sezione: 6
 Progressiva: 50.000
 Q. Progetto: 195.851

193.00

Quote Terreno	-194.96	-195.01		195.48	195.76	-196.37
Quote Progetto		195.10	195.39	195.45	195.51	195.81
Parziali		0.68	2.50		2.50	
Progressiva		-3.18	-2.50	0.00	2.50	2.60
Dislivelli		0.00	0.60	-0.03	-0.27	0.00

Sezione: 7
 Progressiva: 60.000
 Q. Progetto: 196.877

194.00

Quote Terreno	-195.43			195.90	195.99	196.39	-196.66
Quote Progetto		195.59	196.41	196.48	196.54	196.33	
Parziali		1.22	2.50		2.50	0.61	
Progressiva		-3.72	-2.50	0.00	2.50	3.11	
Dislivelli		0.00	1.12	0.58	0.31	0.00	

Sezione: 8
 Progressiva: 69.474
 Q. Progetto: 198.037

195.00

Quote Terreno	196.59	196.49	196.70	197.02
Quote Progetto	196.49	197.57	197.64	196.91
Parziali		1.48	2.50	1.19
Progressiva	-3.98	-2.50	0.00	3.69
Dislivelli	0.00	1.41	0.93	-0.00

Sezione: 9
 Progressiva: 71.536
 Q. Progetto: 198.314

195.00

Quote Terreno	197.09	197.05	197.27	197.39	197.40
Quote Progetto	197.10	197.85	197.91	197.98	197.39
Parziali		1.15	2.50	0.98	
Progressiva	-3.65	-2.50	0.00	2.50	3.48
Dislivelli	-0.00	1.10	0.64	0.59	0.00

Sezione: 10
 Progressiva: 80.000
 Q. Progetto: 199.542

197.00

Quote Terreno	199.17	199.18	199.21	199.22	199.19	199.17	199.17
Quote Progetto	199.08	199.14	199.22	199.20	199.20	199.17	199.17
Parziali	0.30	2.50	2.50	0.41			
Progressiva	-2.80	-2.50	0.00	2.50	2.91		
Dislivelli	0.00	0.29	-0.07	0.00	0.00	0.00	

Sezione: 11
 Progressiva: 83.883
 Q. Progetto: 200.155

198.00

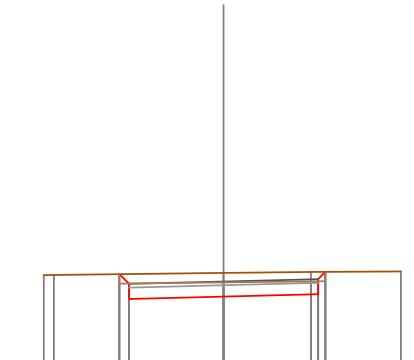

Quote Terreno	200.32	200.33		200.38	200.41	200.42
Quote Progetto			200.35	199.76	199.82	200.41
Parziali				2.50	2.50	
Progressiva		-2.76	-2.50	0.00	2.50	2.89
Dislivelli		0.00	-0.26	-0.63	-0.59	0.00

Sezione: 12
 Progressiva: 90.000
 Q. Progetto: 201.185

199.00

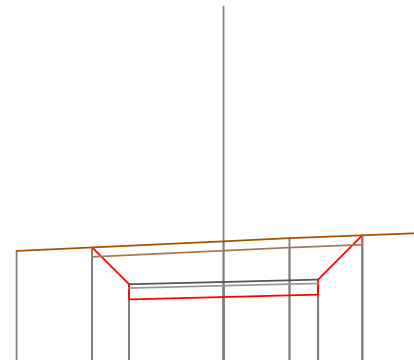

Quote Terreno	202.00			202.26	202.34	202.50
Quote Progetto		202.10	200.72	200.78	200.85	202.42
Parziali		0.98	2.50	2.50	1.17	
Progressiva		-3.48	-2.50	0.00	2.50	3.67
Dislivelli		0.00	-1.02	-1.48	-1.52	0.00

Sezione: 13
 Progressiva: 96.229
 Q. Progetto: 202.314

200.00

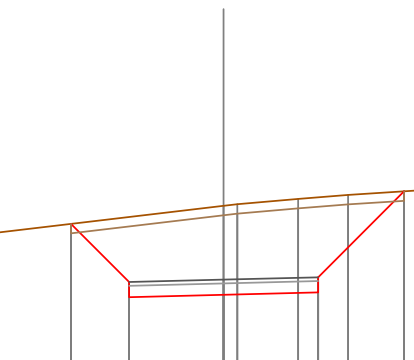

Quote Terreno	203.55			204.26	204.31	204.45	204.55	204.78
Quote Progetto		203.79	201.85	201.91	201.98	204.65		
Parziali		1.54	2.50	2.50	2.27			
Progressiva		-4.04	-2.50	0.00	2.50	4.77		
Dislivelli		0.00	-1.72	-2.35	-2.51	0.00		

Sezione: 14
 Progressiva: 100.000
 Q. Progetto: 203.036

201.00

Quote Terreno	204.60	204.63		205.38	205.66		206.00
Quote Progetto		204.85	202.57	202.64	202.57	205.86	
Parziali			1.88	2.50	2.50	2.89	
Progressiva		-4.38	-2.50	0.00	2.50	5.39	
Dislivelli		-0.00	-2.10	-2.74	-3.10	0.00	

Sezione: 15
 Progressiva: 108.490
 Q. Progetto: 204.774

203.00

Quote Terreno	206.60			207.73	208.13	208.24	208.28	208.49
Quote Progetto		206.94	204.44	204.37	204.31		208.38	
Parziali		2.10	2.50	2.50		3.67		
Progressiva		-4.60	-2.50	0.00	2.50		6.17	
Dislivelli		-0.00	-2.46	-3.35	-3.84		0.00	

Sezione: 16
 Progressiva: 110.000
 Q. Progetto: 205.100

203.00

Quote Terreno	206.91			208.00	208.18	208.48	208.56	208.67
Quote Progetto		207.24	204.76	204.70	204.64		208.57	
Parziali		2.08	2.50	2.50		3.54		
Progressiva		-4.58	-2.50	0.00	2.50		6.04	
Dislivelli		-0.00	-2.42	-3.30	-3.73		0.00	

Sezione: 17
 Progressiva: 120.000
 Q. Progetto: 207.275

205.00

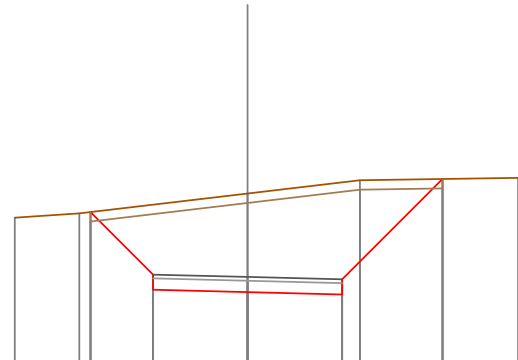

Quote Terreno	-208.84	-208.96	-209.48	-209.83	-209.90
Quote Progetto		208.99	206.94	206.87	206.81
Parziali		1.65	2.50	2.50	2.65
Progressiva		-4.15	-2.50	0.00	2.50
Dislivelli		0.00	-1.85	-2.61	-2.96

Sezione: 18
 Progressiva: 121.103
 Q. Progetto: 207.515

206.00

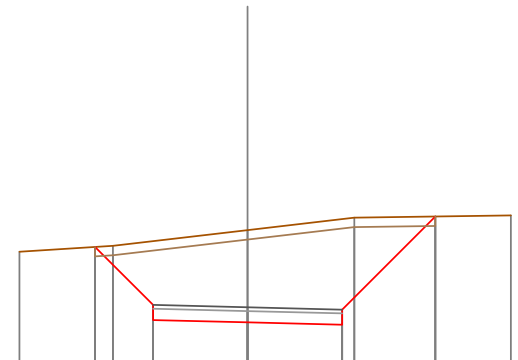

Quote Terreno	-208.98	-209.14	-209.56	-209.88	-209.95
Quote Progetto		209.11	207.18	207.11	207.05
Parziali		1.53	2.50	2.50	2.46
Progressiva		-4.03	-2.50	0.00	2.50
Dislivelli		0.00	-1.69	-2.44	-2.80

Sezione: 19
 Progressiva: 130.000
 Q. Progetto: 209.450

207.00

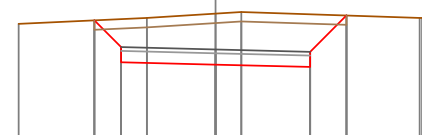

Quote Terreno	-210.13	-210.22	-210.28	-210.40	-210.44	-210.29	-210.29
Quote Progetto		210.22	209.11	209.05	208.99	210.35	
Parziali		0.71	2.50	2.50	0.96		
Progressiva		-3.21	-2.50	0.00	2.50	3.46	
Dislivelli		0.00	-0.74	-1.35	-1.39	0.00	

Sezione: 20
 Progressiva: 133.716
 Q. Progetto: 210.258

208.00

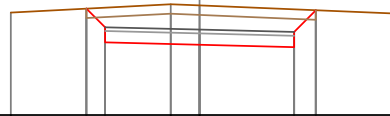

Quote Terreno	-210.71	-210.93	-210.90	-210.69
Quote Progetto	210.81	209.92	209.86	209.80
Parziali	0.49	2.50	2.50	0.57
Progressiva	-2.99	-2.50	0.00	2.50
Dislivelli	0.00	-0.52	-1.04	-1.00

Sezione: 21
 Progressiva: 140.000
 Q. Progetto: 211.625

210.00



Quote Terreno	-211.81	-211.92	-211.94	-211.87	-211.69
Quote Progetto	211.92	211.16	211.23	211.16	211.77
Parziali	0.36	2.50	2.50	0.00	0.00
Progressiva	-2.86	-2.50	0.00	2.50	2.70
Dislivelli	0.00	-0.37	-0.65	-0.61	0.00

Sezione: 22
 Progressiva: 146.351
 Q. Progetto: 213.007

211.00

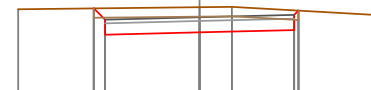

Quote Terreno	-213.22	-213.27	-213.28	-213.07
Quote Progetto	213.24	212.54	212.61	212.67
Parziali	0.30	2.50	2.50	0.00
Progressiva	-2.80	-2.50	0.00	2.50
Dislivelli	-0.00	-0.30	-0.67	-0.52

Sezione: 23
 Progressiva: 148.813
 Q. Progetto: 213.542

212.00

Quote Terreno	-213.77	-213.73	-213.78	-213.82	-213.75	-213.62
Quote Progetto		213.73 213.08	213.14	213.20 213.79		
Parziali			2.50	2.50		
Progressiva		-2.75 -2.50	0.00	2.50 2.89		
Dislivelli		0.00 -0.25	-0.64	-0.59 -0.00		

Sezione: 24
 Progressiva: 150.000
 Q. Progetto: 213.800

212.00

Quote Terreno	-214.10		-214.05	-214.05	-214.09	-214.07	-213.92	-213.90
Quote Progetto		214.08 213.34	213.40	213.46 214.09	214.09			
Parziali		0.34	2.50	2.50				
Progressiva		-2.84 -2.50	0.00	2.50 2.72				
Dislivelli		0.00 -0.34	-0.65	-0.63 -0.00				

Sezione: 25
 Progressiva: 151.276
 Q. Progetto: 214.078

212.00

Quote Terreno	214.44	214.45	214.45	214.44	214.27	214.26
Quote Progetto		214.45 213.82	213.68	213.74 214.43		
Parziali		0.44	2.50	2.50	0.29	
Progressiva		-2.94 -2.50	0.00	2.50 2.79		
Dislivelli		0.00 -0.44	-0.77	-0.70 -0.00		

Sezione: 26
 Progressiva: 160.000
 Q. Progetto: 215.975

214.00

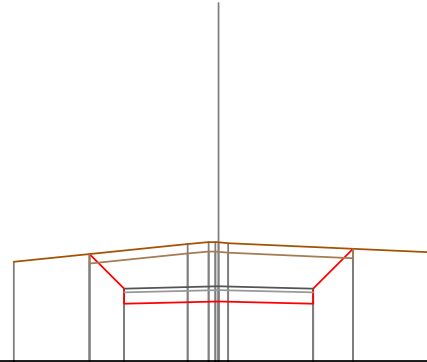

Quote Terreno	-216.62		-217.09	217.12		-216.88
Quote Progetto		216.83	215.51	215.58	215.51	216.97
Parziali		0.91	2.50	2.50	1.05	
Progressiva		-3.41	-2.50	0.00	2.50	3.55
Dislivelli		-0.00	-1.01	-1.56	-1.50	0.00

Sezione: 27
 Progressiva: 160.503
 Q. Progetto: 216.085

214.00

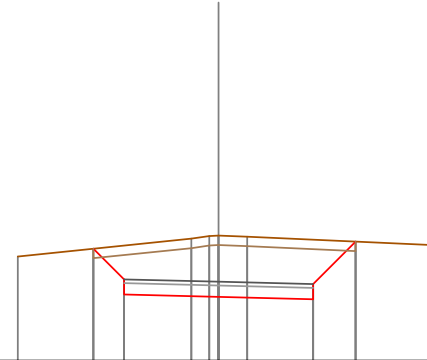

Quote Terreno	-216.75		-217.22	217.30	-217.28	-217.06
Quote Progetto		216.96	215.75	215.68	215.62	217.15
Parziali		0.81	2.50	2.50	1.12	
Progressiva		-3.31	-2.50	0.00	2.50	3.62
Dislivelli		-0.00	-0.89	-1.62	-1.57	0.00

Sezione: 28
 Progressiva: 163.072
 Q. Progetto: 216.644

215.00

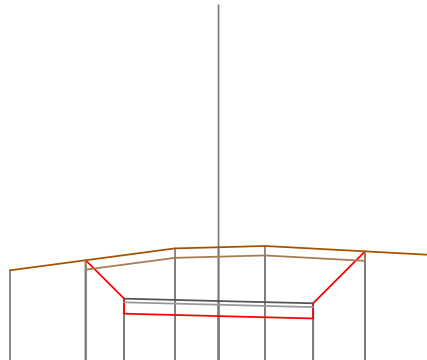

Quote Terreno	-217.46		-218.03	218.07	-218.10	-217.85
Quote Progetto		217.72	216.31	216.24	216.18	217.96
Parziali		1.01	2.50	2.50	1.37	
Progressiva		-3.51	-2.50	0.00	2.50	3.87
Dislivelli		0.00	-1.15	-1.82	-1.85	0.00

Sezione: 29
 Progressiva: 165.642
 Q. Progetto: 217.203

215.00

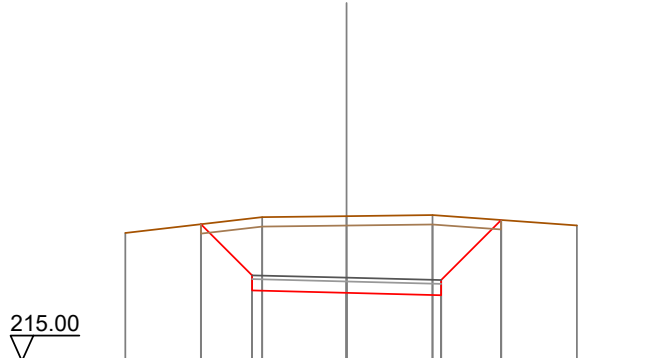

Quote Terreno	-218.39		218.80	218.83	218.86		-218.59
Quote Progetto		218.62	216.87	216.80	216.74	218.73	
Parziali			1.35	2.50	2.50	1.59	
Progressiva		-3.85	-2.50	0.00	2.50	4.09	
Dislivelli		0.00	-1.51	-2.03	-2.10	-0.00	

Sezione: 30
 Progressiva: 169.305
 Q. Progetto: 217.999

216.00

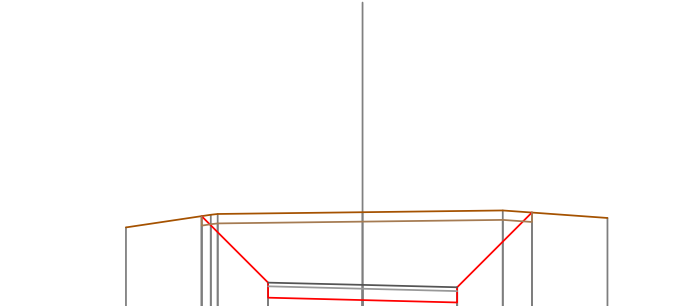

Quote Terreno	-219.52	219.85	219.88		219.92		219.97	-219.77
Quote Progetto		219.82	217.86		217.60		217.54	219.92
Parziali			1.76		2.50		2.50	1.98
Progressiva		-4.26	-2.50		0.00		2.50	4.48
Dislivelli		0.00	-1.83		-2.32		-2.42	0.00

Sezione: 31
 Progressiva: 170.000
 Q. Progetto: 218.151

216.00

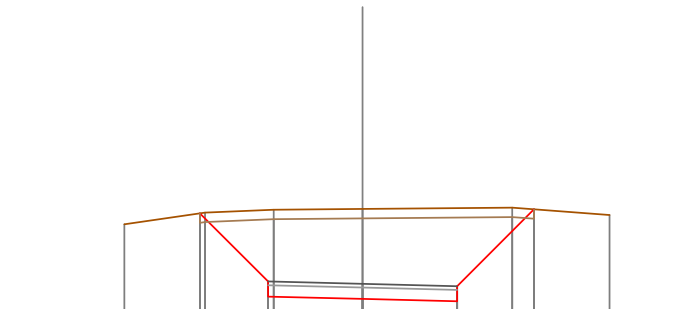

Quote Terreno	-219.72	220.03	220.11	220.13		220.16		-219.97
Quote Progetto		220.01	217.81	217.75		217.69		220.12
Parziali			1.80	2.50	2.50	2.03		
Progressiva		-4.30	-2.50	0.00		2.50		4.53
Dislivelli		-0.00	-1.89	-2.38		-2.46		0.00

Sezione: 32
 Progressiva: 173.768
 Q. Progetto: 218.970

217.00

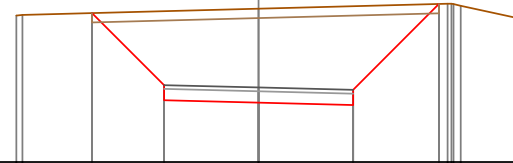

Quote Terreno	220.87	220.89		221.05		221.19	221.13	220.82
Quote Progetto		220.94	218.63	218.57	218.51	221.18		
Parziali			1.91	2.50	2.50	2.27		
Progressiva		-4.41	-2.50	0.00	2.50	4.77		
Dislivelli		-0.00	-1.96	-2.48	-2.61	-0.00		

Sezione: 33
 Progressiva: 178.232
 Q. Progetto: 219.941

218.00

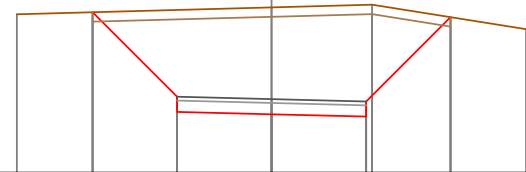

Quote Terreno	222.18			222.37	222.44		221.79
Quote Progetto		222.24	219.60	219.54	219.48	222.11	
Parziali		2.24	2.50	2.50	2.23		
Progressiva		-4.74	-2.50	0.00	2.50	4.73	
Dislivelli		0.00	-2.30	-2.83	-2.96	0.00	

Sezione: 34
 Progressiva: 178.838
 Q. Progetto: 220.073

218.00

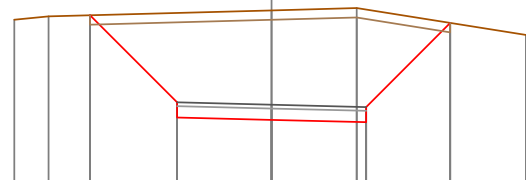

Quote Terreno	222.32	222.41		222.57	222.63		221.92
Quote Progetto		222.44	219.74	219.67	219.61	222.24	
Parziali		2.30	2.50	2.50	2.23		
Progressiva		-4.80	-2.50	0.00	2.50	4.73	
Dislivelli		0.00	-2.36	-2.89	-2.98	0.00	

Sezione: 35
 Progressiva: 180.000
 Q. Progetto: 220.326

218.00

Quote Terreno	-222.62	-222.88	-222.95	-222.98	-222.13
Quote Progetto		222.80	219.99	219.93	219.86
Parziali		2.41	2.50	2.50	2.19
Progressiva		-4.91	-2.50	0.00	2.50
Dislivelli		0.00	-2.52	-3.03	-2.95

Sezione: 36
 Progressiva: 187.349
 Q. Progetto: 221.924

220.00

Quote Terreno	-225.12	-225.30	-225.50	-225.50	-224.73
Quote Progetto		225.24	221.59	221.52	221.46
Parziali		3.25	2.50	2.50	2.79
Progressiva		-5.75	-2.50	0.00	2.50
Dislivelli		0.00	-3.41	-3.97	-3.64

Sezione: 37
 Progressiva: 190.000
 Q. Progetto: 222.501

221.00

Quote Terreno	-226.10	-226.16	-226.28	-226.44	-226.43
Quote Progetto		226.28	222.16	222.10	222.04
Parziali		3.72	2.50	2.50	3.02
Progressiva		-6.22	-2.50	0.00	2.50
Dislivelli		0.00	-3.82	-4.33	-3.95

Sezione: 38
 Progressiva: 195.859
 Q. Progetto: 223.775

222.00

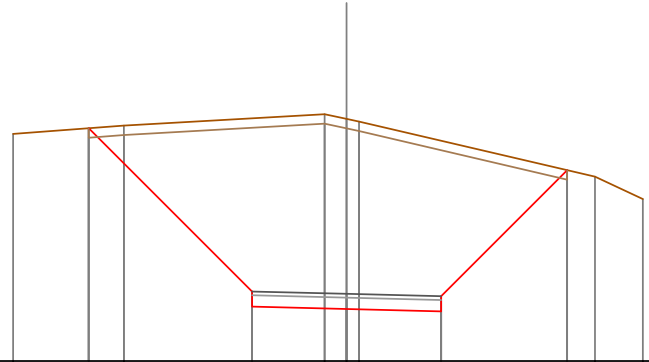

Quote Terreno	-228.01	-228.23	-228.53	-228.33	-226.87	-226.28
Quote Progetto		228.16	223.44	223.38	223.31	227.05
Parziali		4.32	2.50	2.50	3.33	
Progressiva		-6.82	-2.50	0.00	2.50	5.83
Dislivelli		0.00	-4.58	-5.03	-4.51	0.00

Sezione: 39
 Progressiva: 197.298
 Q. Progetto: 224.088

222.00

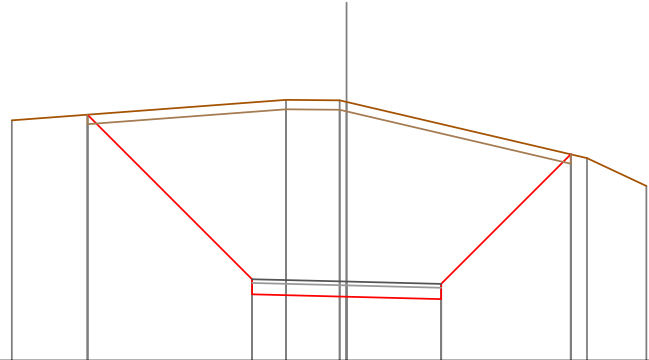

Quote Terreno	-228.35	-228.89	-228.88	-228.84	-227.35	-226.62
Quote Progetto		228.50	223.75	223.69	223.63	227.45
Parziali		4.35	2.50	2.50	3.43	
Progressiva		-6.85	-2.50	0.00	2.50	5.93
Dislivelli		0.00	-4.68	-5.15	-4.63	0.00

Sezione: 40
 Progressiva: 200.000
 Q. Progetto: 224.676

223.00

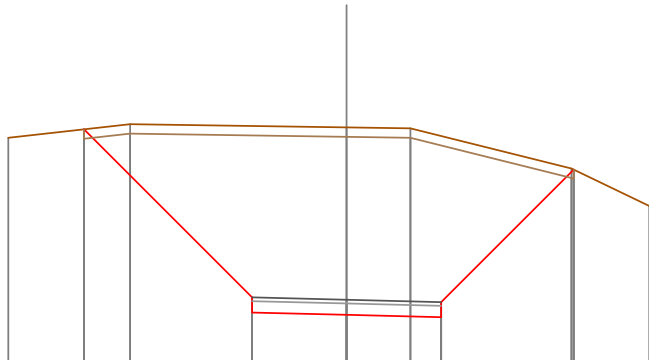

Quote Terreno	-228.96	-229.32	-229.23	-229.21	-228.15	-227.15
Quote Progetto		229.18	224.34	224.28	224.21	228.12
Parziali		4.44	2.50	2.50	3.51	
Progressiva		-6.94	-2.50	0.00	2.50	6.01
Dislivelli		0.00	-4.53	-4.96	-4.79	0.00

Sezione: 41
 Progressiva: 202.746
 Q. Progetto: 225.273

223.00

Quote Terreno	-229.82	-229.81	-229.69	-229.59	-229.52	-228.97	-227.69
Quote Progetto		229.76	224.94	224.87	224.81	228.68	
Parziali			4.43	2.50	2.50	3.47	
Progressiva		-6.93	-2.50	0.00	2.50	5.97	
Dislivelli		0.00	-4.31	-4.72	-4.73	-0.00	

Sezione: 42
 Progressiva: 208.195
 Q. Progetto: 226.458

224.00

Quote Terreno	-230.82	-230.71	-230.49	-230.45	-230.27	-229.80	-228.66
Quote Progetto		230.76	226.12	226.06	226.00	229.79	
Parziali			4.24	2.50	2.50	3.39	
Progressiva		-6.74	-2.50	0.00	2.50	5.89	
Dislivelli		0.00	-4.06	-4.39	-4.34	-0.00	

Sezione: 43
 Progressiva: 209.138
 Q. Progetto: 226.664

225.00

Quote Terreno	-230.97	-230.84	-230.75	-230.61	-230.45	-229.79	-228.95
Quote Progetto		230.90	226.33	226.26	226.20	229.91	
Parziali			4.18	2.50	2.50	3.31	
Progressiva		-6.68	-2.50	0.00	2.50	5.81	
Dislivelli		-0.00	-4.01	-4.35	-4.30	0.00	

Sezione: 44
 Progressiva: 210.000
 Q. Progetto: 226.851

225.00

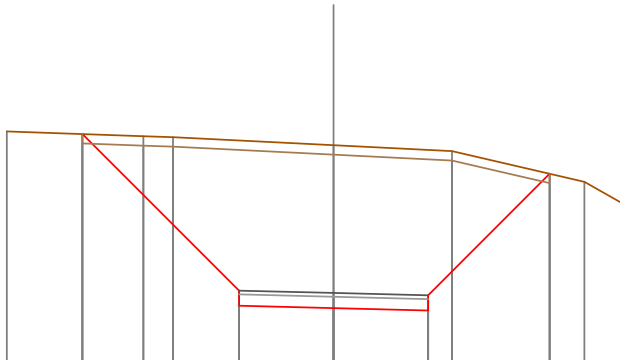

Quote Terreno	-231.13	-231.00	-230.97	-230.76	-230.60	-229.79	-229.18
Quote Progetto		231.06		226.51	226.45	226.39	230.01
Parziali		4.14	2.50	2.50	3.22		
Progressiva		-6.64	-2.50	0.00	2.50	5.72	
Dislivelli		0.00	-3.97	-4.31	-4.25	-0.00	

Sezione: 45
 Progressiva: 211.280
 Q. Progetto: 227.130

225.00

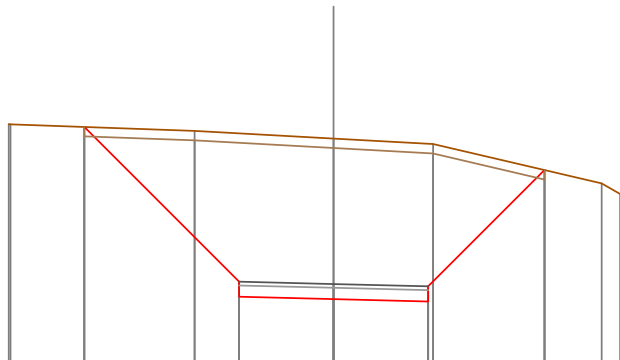

Quote Terreno	231.36	231.36	-231.18	-230.98	-230.83	-229.79	-229.51
Quote Progetto		231.28	226.79	226.73	226.67	230.14	
Parziali		4.09	2.50	2.50	3.08		
Progressiva		-6.59	-2.50	0.00	2.50	5.58	
Dislivelli		0.00	-3.92	-4.25	-4.17	0.00	

Sezione: 46
 Progressiva: 213.422
 Q. Progetto: 227.596

226.00

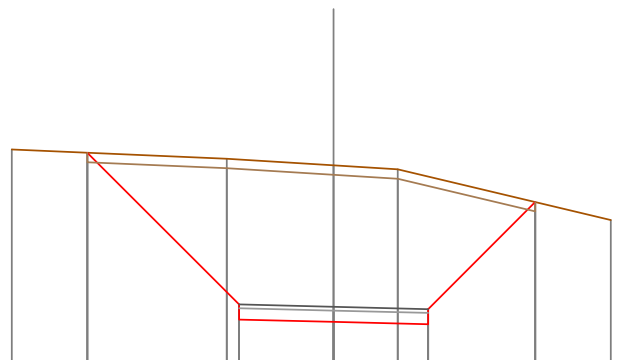

Quote Terreno	-231.76	-231.51	-231.34	-231.23	-229.89	
Quote Progetto		231.67	227.26	227.20	227.13	230.37
Parziali		4.01	2.50	2.50	2.83	
Progressiva		-6.51	-2.50	0.00	2.50	5.33
Dislivelli		-0.00	-3.83	-4.14	-3.91	0.00

Sezione: 47
 Progressiva: 220.000
 Q. Progetto: 229.026

227.00

Quote Terreno	-233.31	-232.89	-232.51	-232.38	-232.00	-230.89
Quote Progetto	233.12	228.56	228.63	228.56	231.30	
Parziali		4.16	2.50	2.50	2.34	
Progressiva	-6.66	-2.50	0.00	2.50	4.84	
Dislivelli	-0.00	-3.75	-3.75	-3.22	0.00	

Sezione: 48
 Progressiva: 235.743
 Q. Progetto: 232.451

230.00

Quote Terreno	-238.46	-238.41	-237.90	-237.21	-236.93	-235.78	-235.16
Quote Progetto	238.30	232.11	232.05	231.99	235.62		
Parziali		5.78	2.50	2.50	3.23		
Progressiva	-8.28	-2.50	0.00	2.50	5.73		
Dislivelli	0.00	-4.90	-4.88	-4.37	0.00		

Sezione: 49
 Progressiva: 238.107
 Q. Progetto: 232.965

231.00

Quote Terreno	239.61	239.59	-238.65	-238.26	-237.65	-236.36	-236.27	-235.75
Quote Progetto	239.31	232.63	232.56	232.50	236.23	236.27		
Parziali		6.28	2.50	2.50	3.33			
Progressiva	-8.78	-2.50	0.00	2.50	5.83			
Dislivelli	0.00	-5.24	-5.09	-4.54	0.00			

Sezione: 50
 Progressiva: 240.000
 Q. Progetto: 233.377

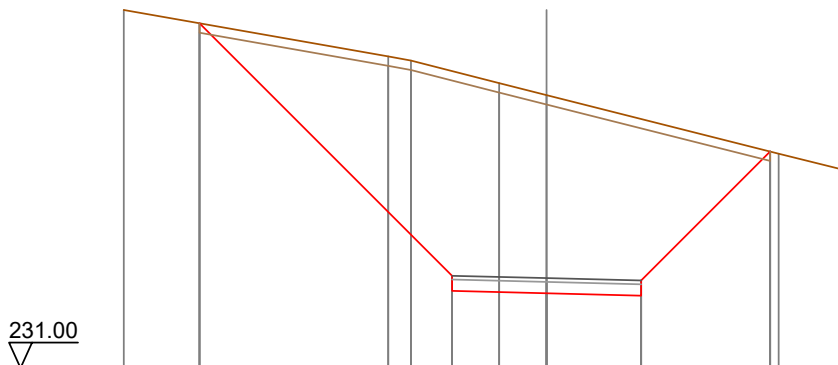

Quote Terreno	-240.47	-239.24	-239.13	-238.53	-238.22	-236.67	-236.23
Quote Progetto	240.12	233.04	232.98	232.91	236.73		
Parziali		6.68	2.50	2.50	3.41		
Progressiva	-9.18	-2.50	0.00	2.50	5.91		
Dislivelli	-0.00	-5.41	-5.24	-4.67	0.00		

Sezione: 51
 Progressiva: 240.471
 Q. Progetto: 233.479

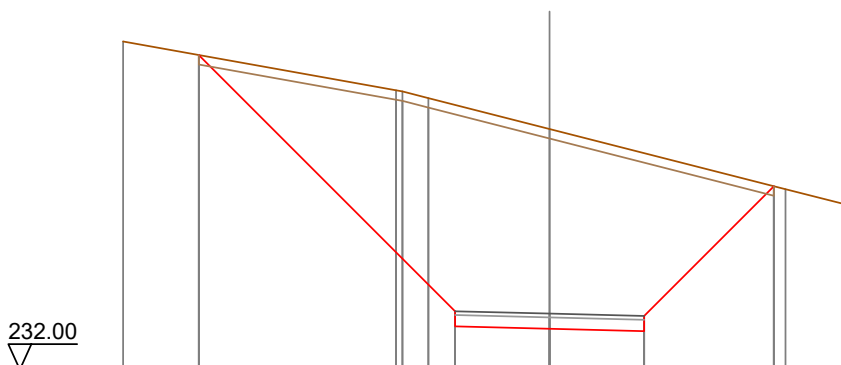

Quote Terreno	-240.68	239.39	239.35	239.18	-238.36	-236.77	-236.34
Quote Progetto	240.32	233.14	233.08	233.02	236.85		
Parziali		6.78	2.50	2.50	3.43		
Progressiva	-9.28	-2.50	0.00	2.50	5.93		
Dislivelli	-0.00	-5.46	-5.28	-4.71	0.00		

Sezione: 52
 Progressiva: 245.181
 Q. Progetto: 234.503

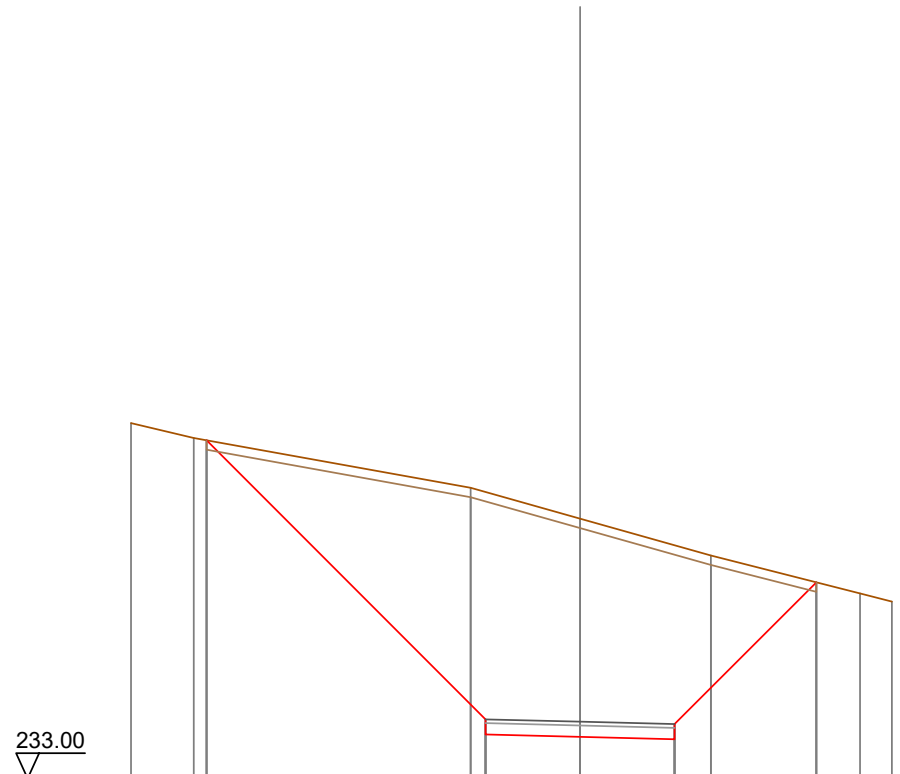

Quote Terreno		242.40	242.01		240.69	239.87		238.90		237.89	237.68
Quote Progetto			241.95		234.17	234.10		234.04		238.19	
Parziali				7.38		2.50	2.50		3.75		
Progressiva			-9.88		-2.50	0.00		2.50		6.25	
Dislivelli			0.00		-6.01	-5.77		-5.13		0.00	

Sezione: 53
 Progressiva: 247.544
 Q. Progetto: 235.018

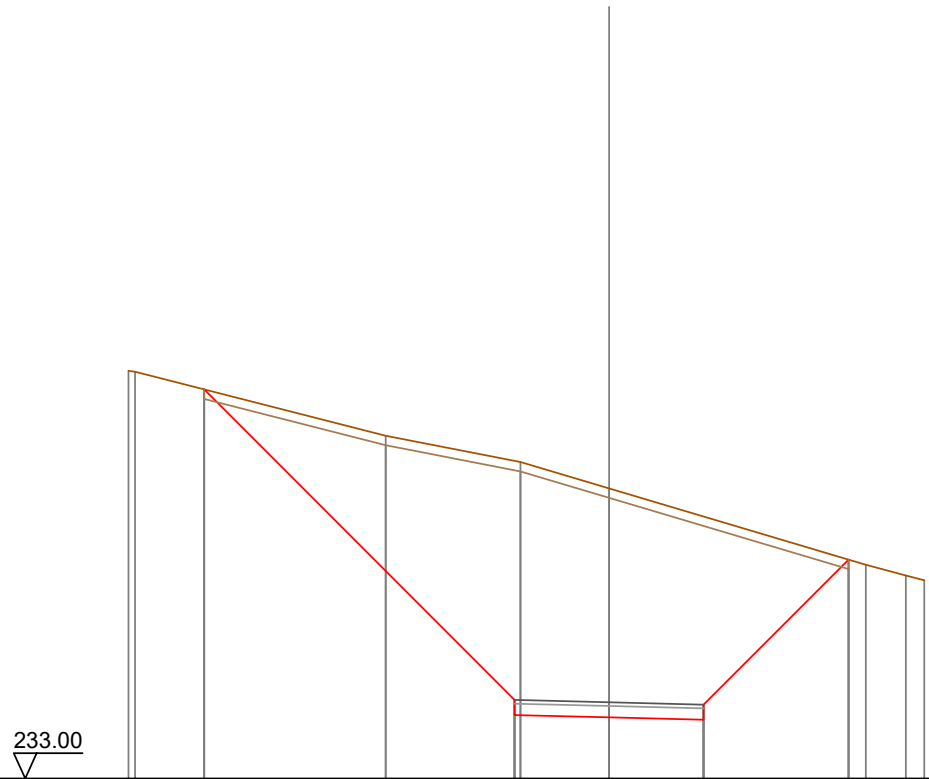

Quote Terreno		243.78 243.76		242.07	241.37 241.37	240.67		238.66 238.37 238.24
Quote Progetto			243.29		234.68	234.62	234.56	238.79
Parziali				8.21	2.50	2.50	3.84	
Progressiva			-10.71		-2.50	0.00	2.50	6.34
Dislivelli			0.00		-6.32	-6.06	-5.38	0.00

Sezione: 54
 Progressiva: 249.908
 Q. Progetto: 235.532

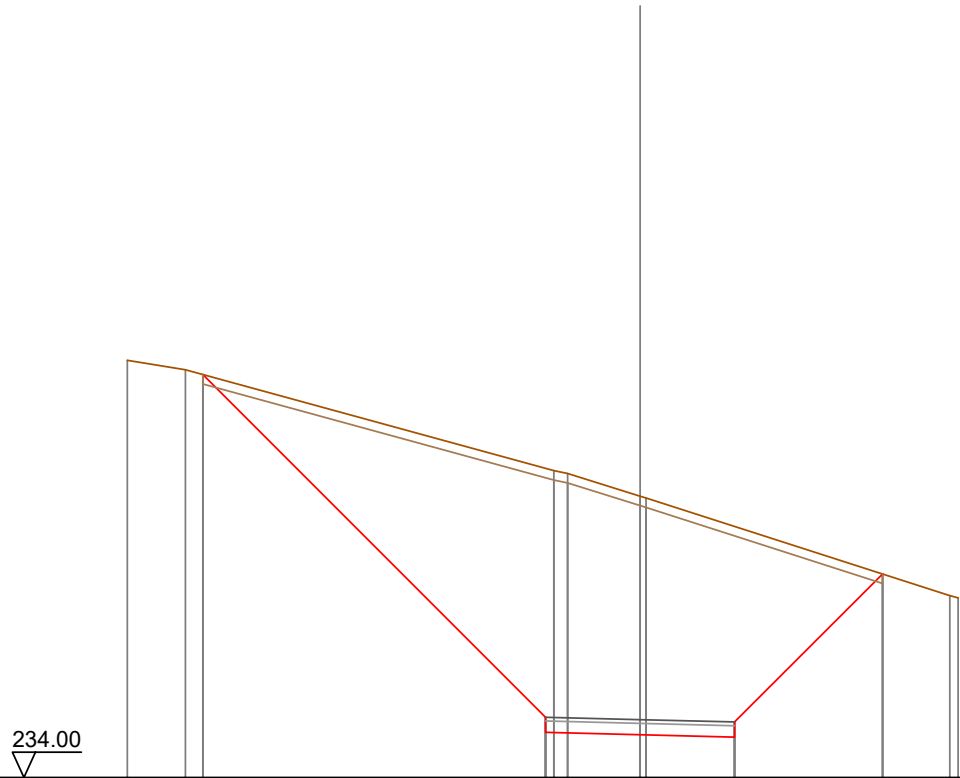

Quote Terreno		245.03	244.79		242.12 242.04	241.44 241.39		238.81 238.75
Quote Progetto			244.66		235.19	235.13	235.07	239.38
Parziali				9.06		2.50	2.50	3.91
Progressiva			-11.56		-2.50	0.00	2.50	6.41
Dislivelli			0.00		-6.58	-6.31	-5.57	0.00

Sezione: 55
 Progressiva: 260.000
 Q. Progetto: 237.727

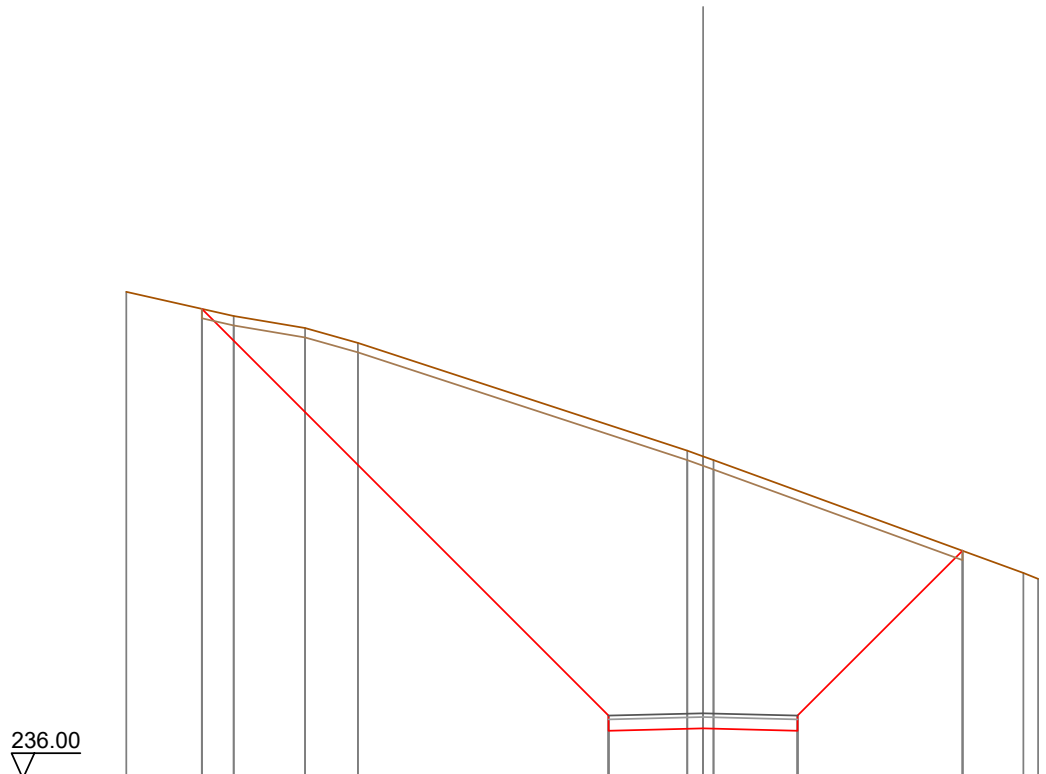

Quote Terreno		248.87	248.23	247.91	247.52		244.67	244.42		241.44	241.28
Quote Progetto			248.42				237.26	237.33	237.26		242.03
Parziali				10.76			2.50	2.50	4.36		
Progressiva			-13.26				-2.50	0.00	2.50		6.86
Dislivelli			0.00				-7.69	-7.19	-6.35		-0.00

Sezione: 56
 Progressiva: 277.792
 Q. Progetto: 241.597

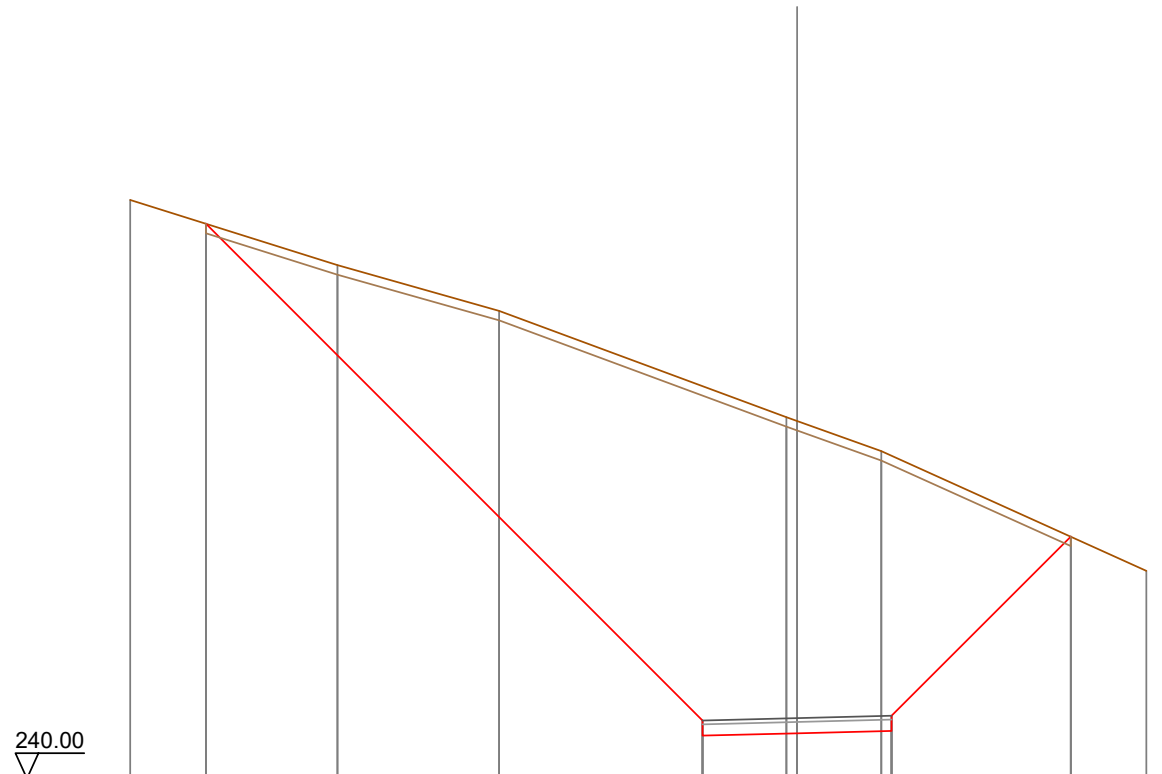

Quote Terreno	-255.30	-253.58	-252.37	-249.56	-249.46	-248.66	-245.49
Quote Progetto	-254.67	-241.13	-241.20	-241.26	-246.40		
Parziali		13.14	2.50	2.50	4.74		
Progressiva	-15.64	-2.50	0.00	2.50	7.24		
Dislivelli	-0.00	-8.84	-8.26	-7.28	0.00		

Sezione: 57
 Progressiva: 280.000
 Q. Progetto: 242.077

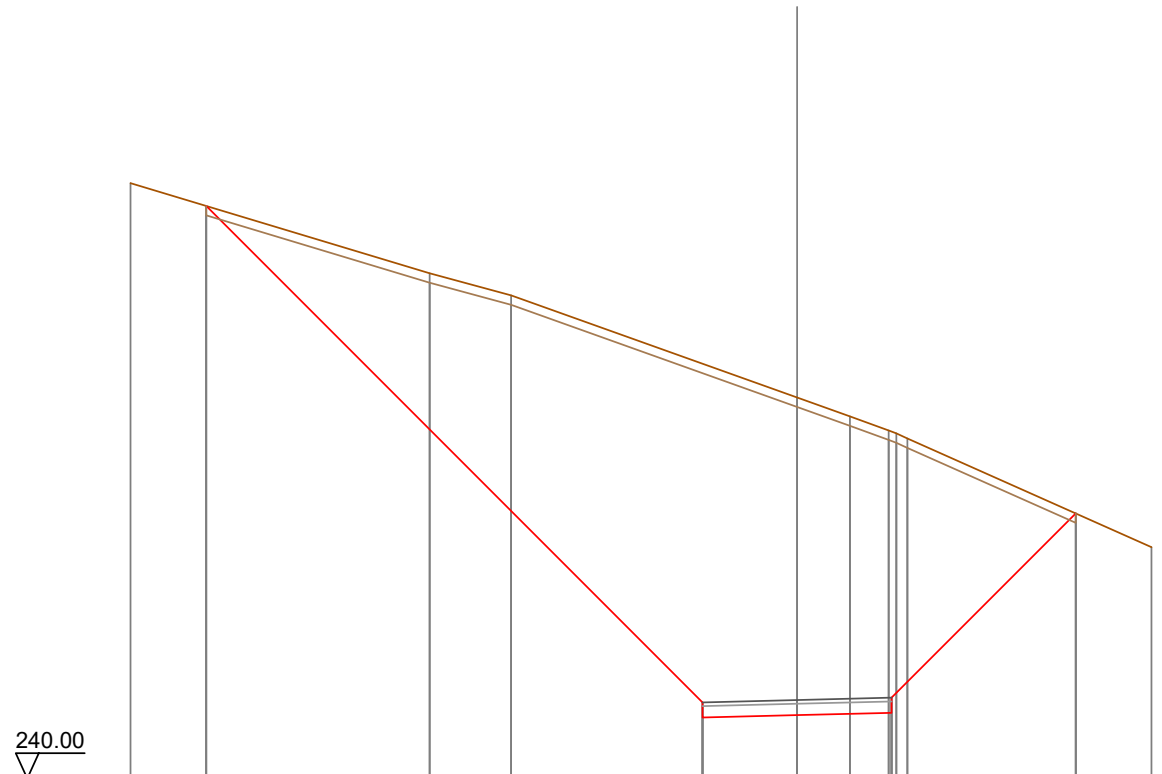

Quote Terreno		255.75		253.36	252.78		250.08	249.58	249.21	248.99		247.01	246.12
Quote Progetto			255.14				241.61	241.68		241.74		247.01	
Parziali				13.13			2.50	2.50		4.87			
Progressiva			-15.63				-2.50	0.00		2.50		7.37	
Dislivelli			-0.00				-8.95	-8.40		-7.44		0.00	

Sezione: 58
 Progressiva: 280.793
 Q. Progetto: 242.250

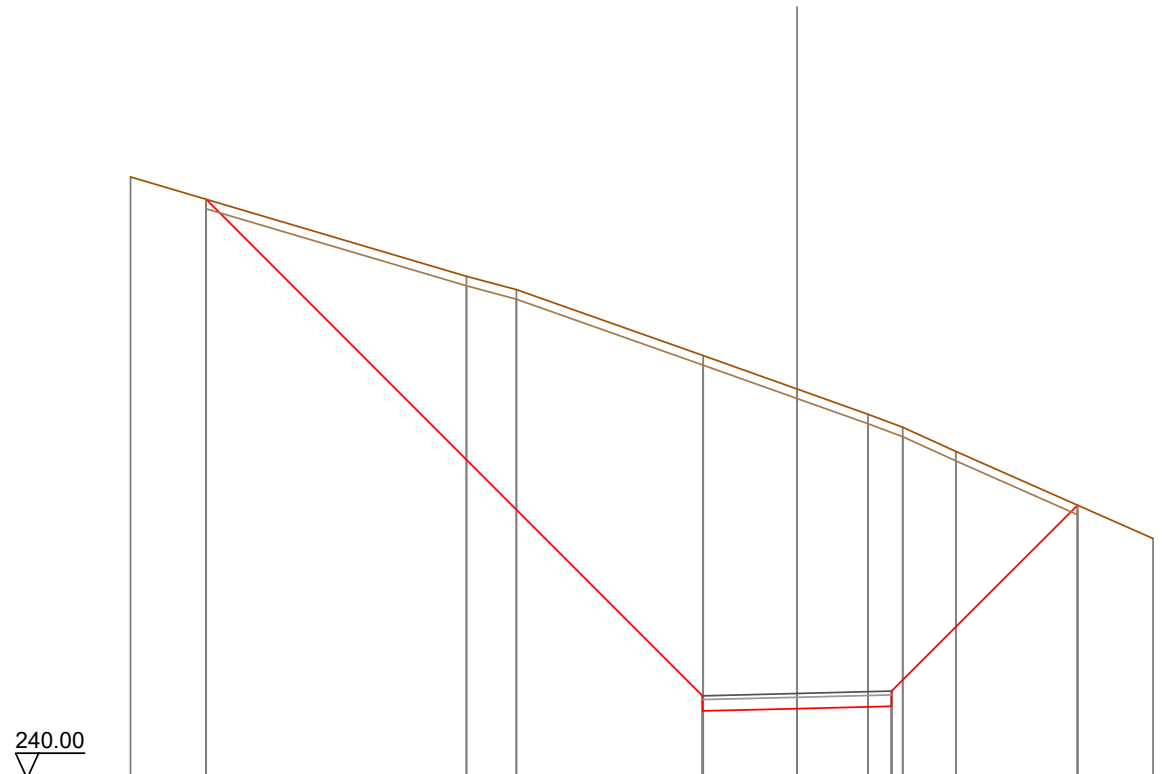

Quote Terreno		255.91		253.28	252.93		251.18	250.30	249.63	249.29	248.65		246.35
Quote Progetto		255.32					241.79	241.85	241.91	241.91		247.23	
Parziali			13.13				2.50	2.50		4.92			
Progressiva		-15.63					-2.50	0.00	2.50			7.42	
Dislivelli		0.00					-9.00	-8.45	-7.49			0.00	

Sezione: 59
 Progressiva: 283.795
 Q. Progetto: 242.903

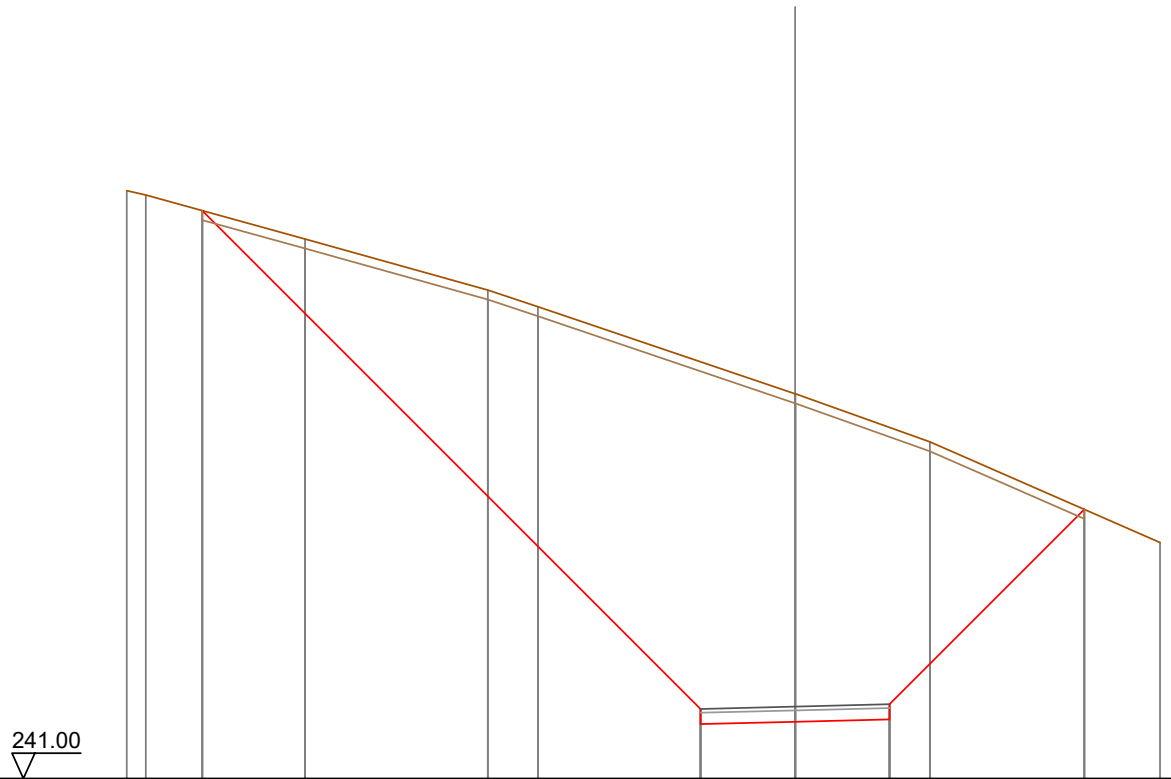

Quote Terreno		256.55	256.43		255.27		253.92	253.48		251.17		249.90		248.12	247.24
Quote Progetto			256.02						242.44	242.50		242.57		248.12	
Parziali				13.18					2.50	2.50		5.15			
Progressiva			-15.68						-2.50	0.00		2.50		7.65	
Dislivelli			0.00						-9.18	-8.67		-7.72		0.00	

Sezione: 60
 Progressiva: 289.761
 Q. Progetto: 244.200

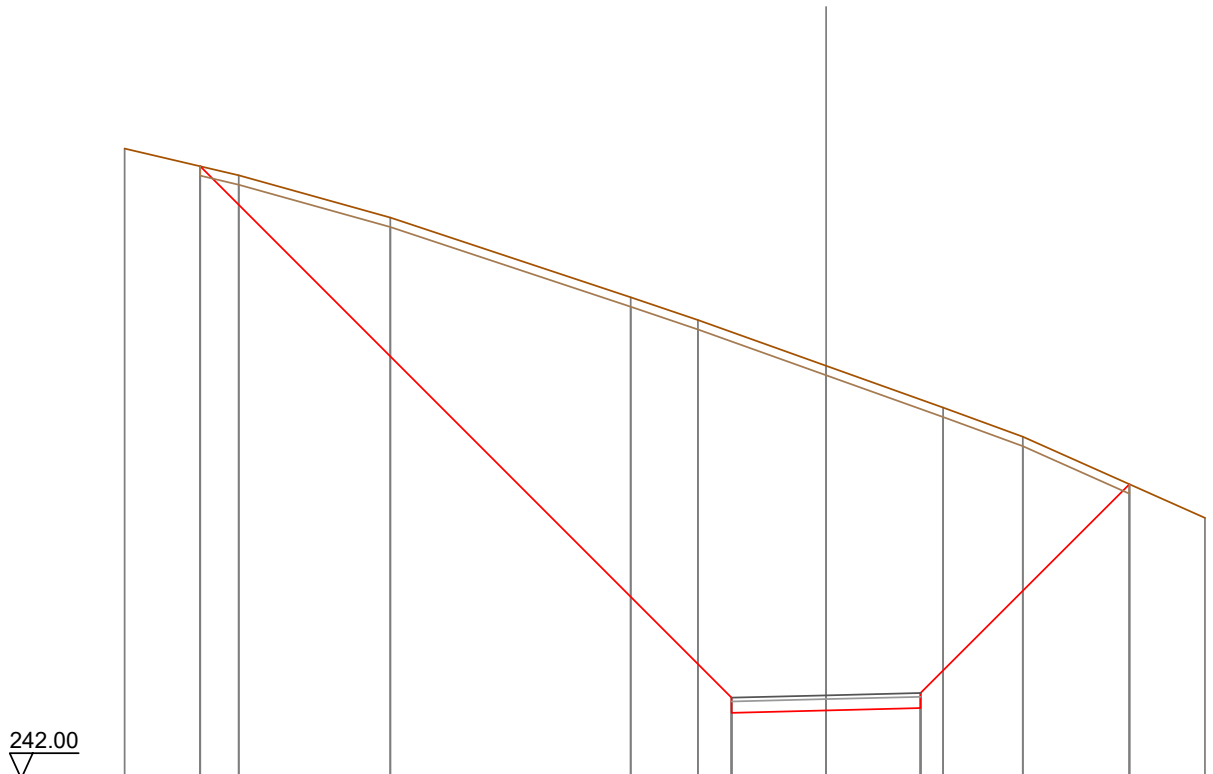

Quote Terreno	-258.66	-257.95	-256.84	-254.73	-254.12	-252.92	-251.81	-251.04	-248.89
Quote Progetto		258.19			243.74	243.80	243.86		249.78
Parziali			14.06		2.50	2.50	5.52		
Progressiva		-16.56			-2.50	0.00	2.50		8.02
Dislivelli		0.00			-9.67	-9.12	-8.16		0.00

Sezione: 61
 Progressiva: 290.000
 Q. Progetto: 244.252

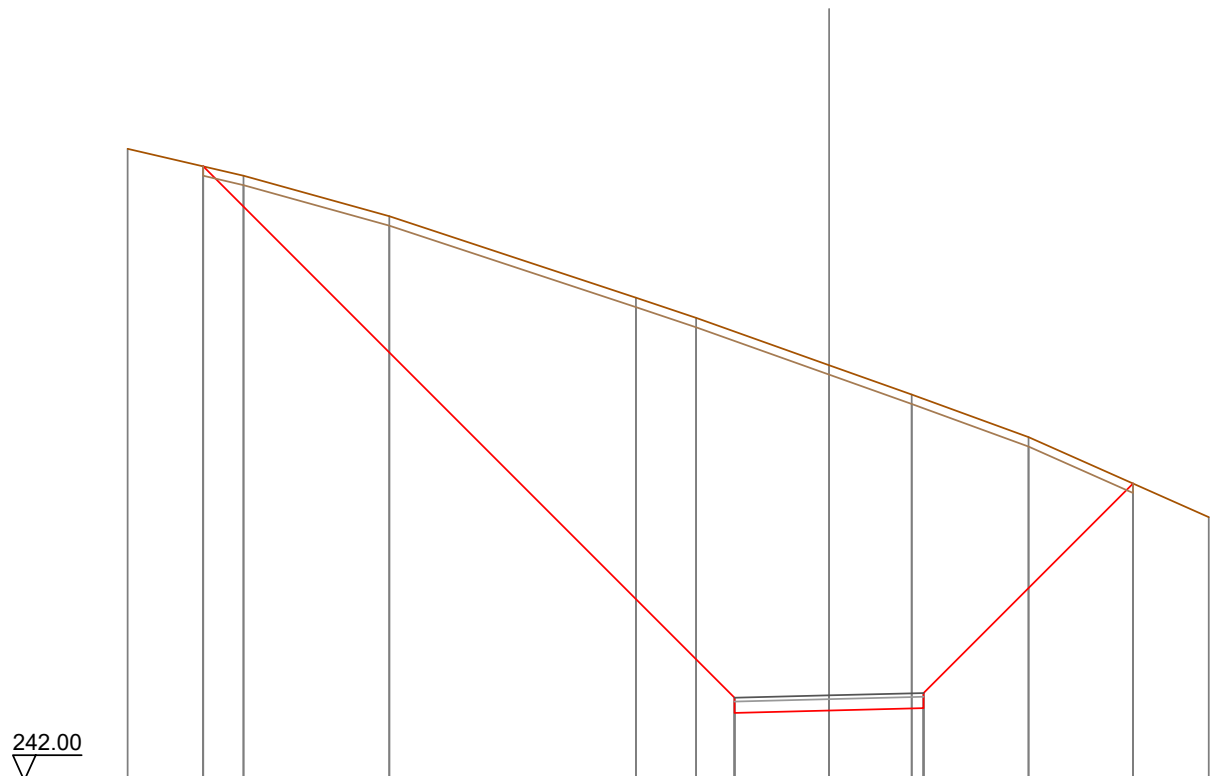

Quote Terreno		258.71	258.00	256.92		254.77	254.23		252.99	252.21	251.08		248.97
Quote Progetto			258.24					243.79	243.85	243.91		249.86	
Parziali				14.05			2.50	2.50		5.54			
Progressiva			-16.55				-2.50	0.00	2.50		8.04		
Dislivelli			-0.00				-9.68	-9.13	-8.18		0.00		

Sezione: 62
 Progressiva: 292.762
 Q. Progetto: 244.853

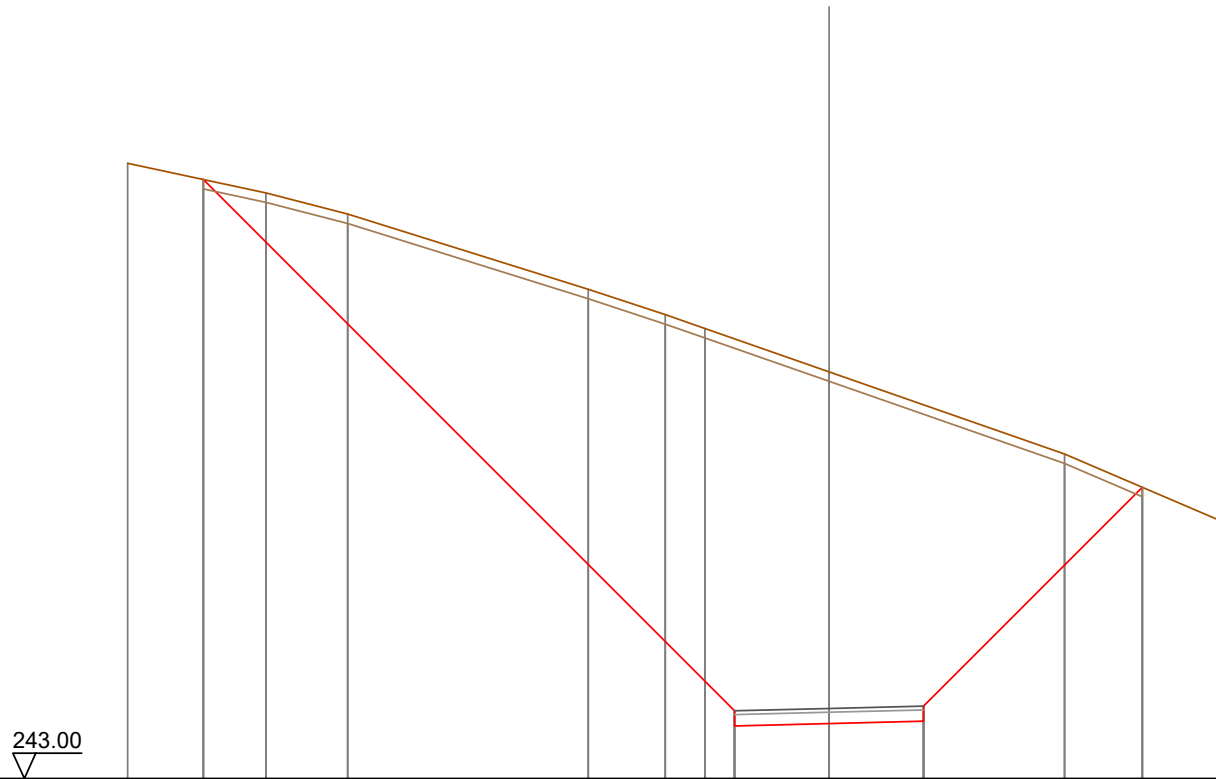

Quote Terreno		259.27		258.49		257.93		255.94		255.27		254.90		253.76		251.58		249.85
Quote Progetto			258.84									244.39		244.45		244.52		250.70
Parziali					14.05							2.50		2.50		5.79		
Progressiva			-16.55									-2.50		0.00		2.50		8.29
Dislivelli			0.00									-9.84		-9.30		-8.37		0.00

Sezione: 63
 Progressiva: 295.763
 Q. Progetto: 245.506

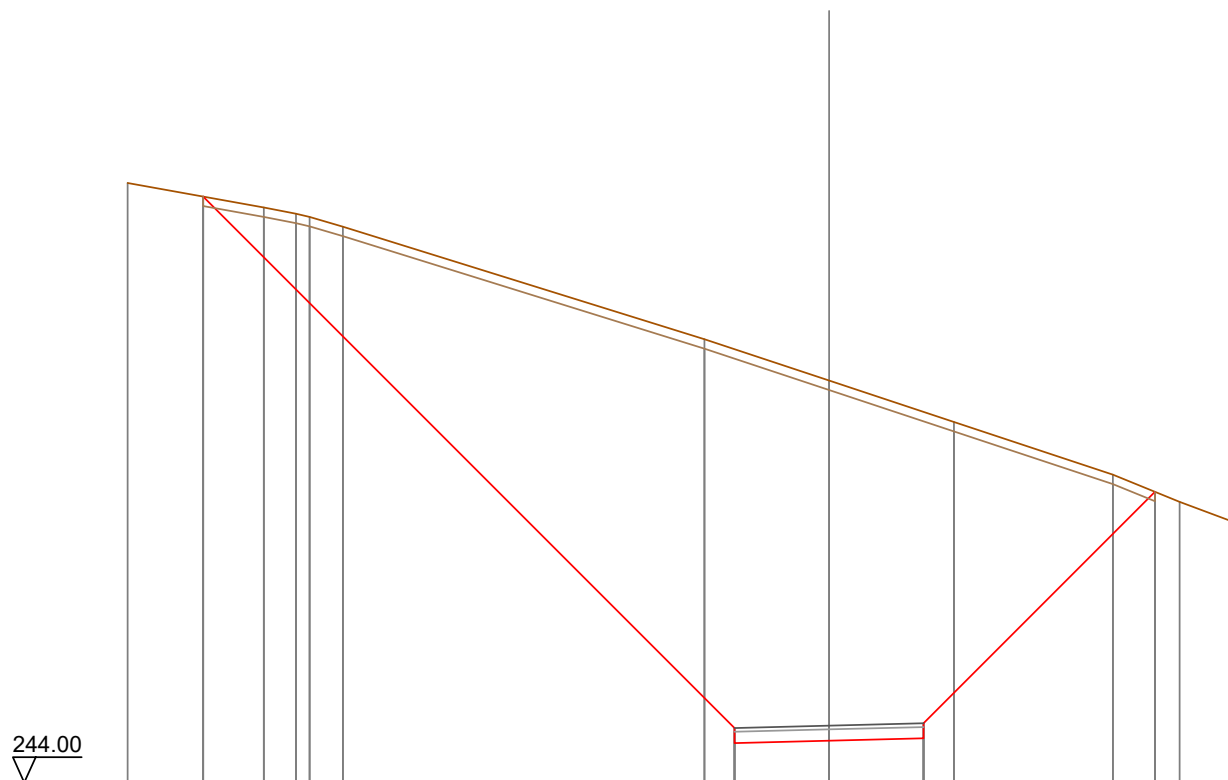

Quote Terreno		259.86		259.21	259.04	258.96	258.70			255.72		254.63		253.54		252.14	251.42	250.92
Quote Progetto			259.50							245.04		245.11		245.17			251.89	
Parziali							14.05			2.50		2.50			6.12			
Progressiva			-16.55							-2.50		0.00		2.50			8.62	
Dislivelli			0.00							-10.02		-9.53		-8.64			0.00	

Sezione: 64
 Progressiva: 300.000
 Q. Progetto: 246.427

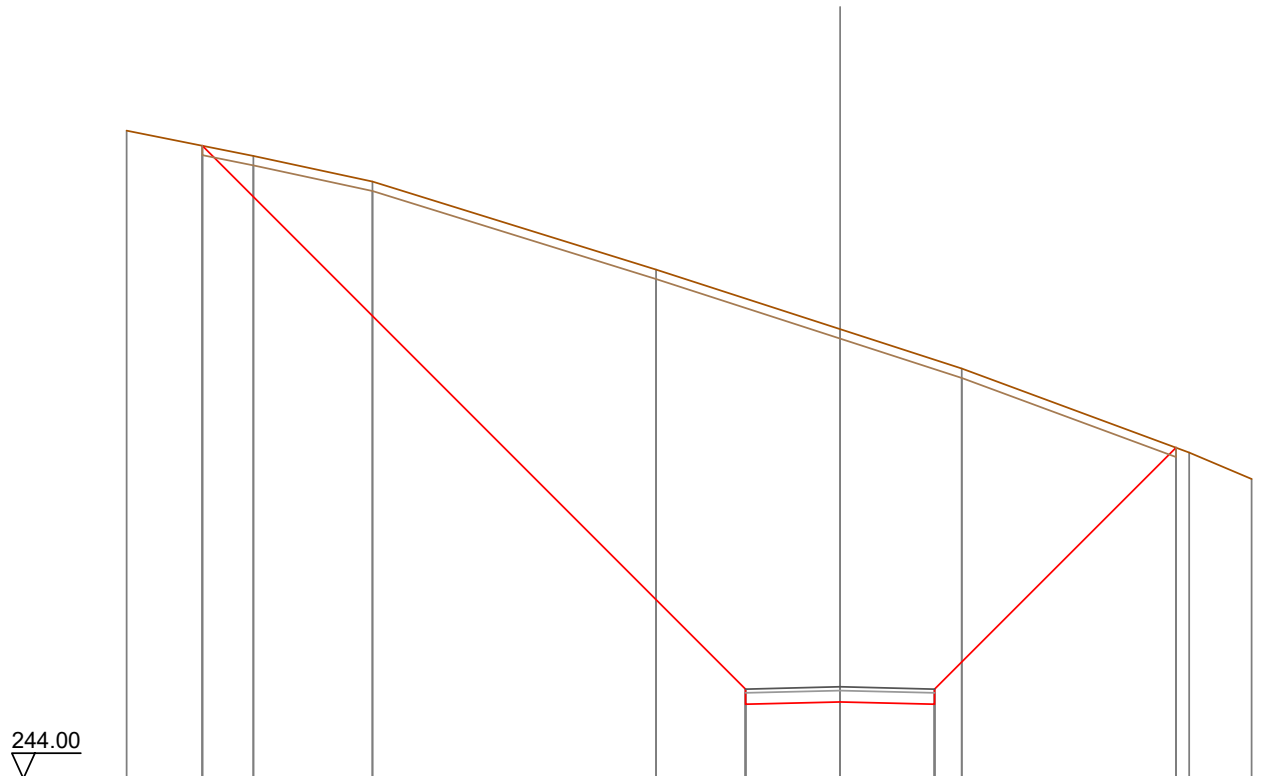

Quote Terreno	261.14	260.46	259.79	257.46	245.96	246.03	255.88	254.85	252.62	251.92
Quote Progetto		260.73			245.96	246.03		245.96	252.75	
Parziali			14.37		2.50	2.50		6.39		
Progressiva		-16.87			-2.50	0.00		2.50	8.89	
Dislivelli		0.00			-10.33	-9.86		-9.11	0.00	

Sezione: 65
 Progressiva: 306.183
 Q. Progetto: 247.772

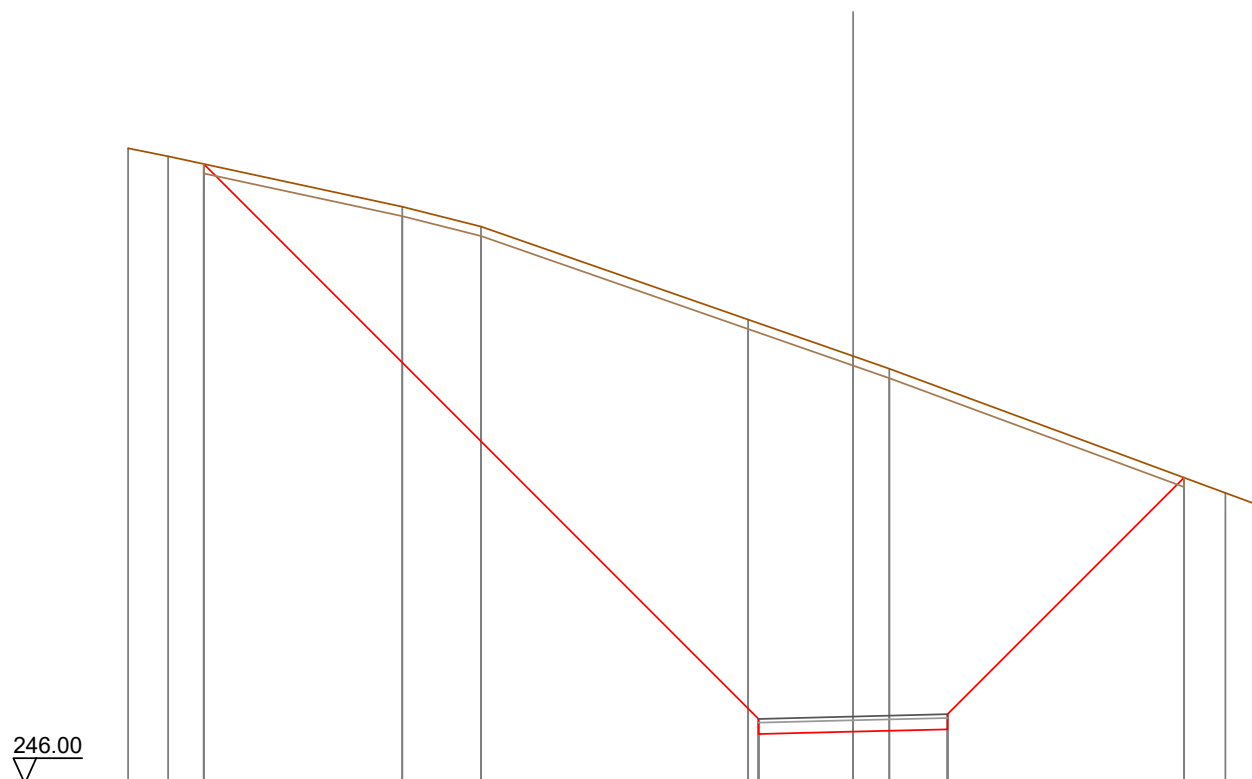

Quote Terreno	262.80	262.59	261.26	260.73	258.27	257.30	256.97	254.09	253.69	253.35
Quote Progetto		262.39			247.31	247.37	247.43		254.09	
Parziali			14.68		2.50	2.50	6.26			
Progressiva		-17.18			-2.50	0.00	2.50		8.76	
Dislivelli		0.00			-10.46	-9.93	-8.97		0.00	

Sezione: 66
 Progressiva: 309.475
 Q. Progetto: 248.488

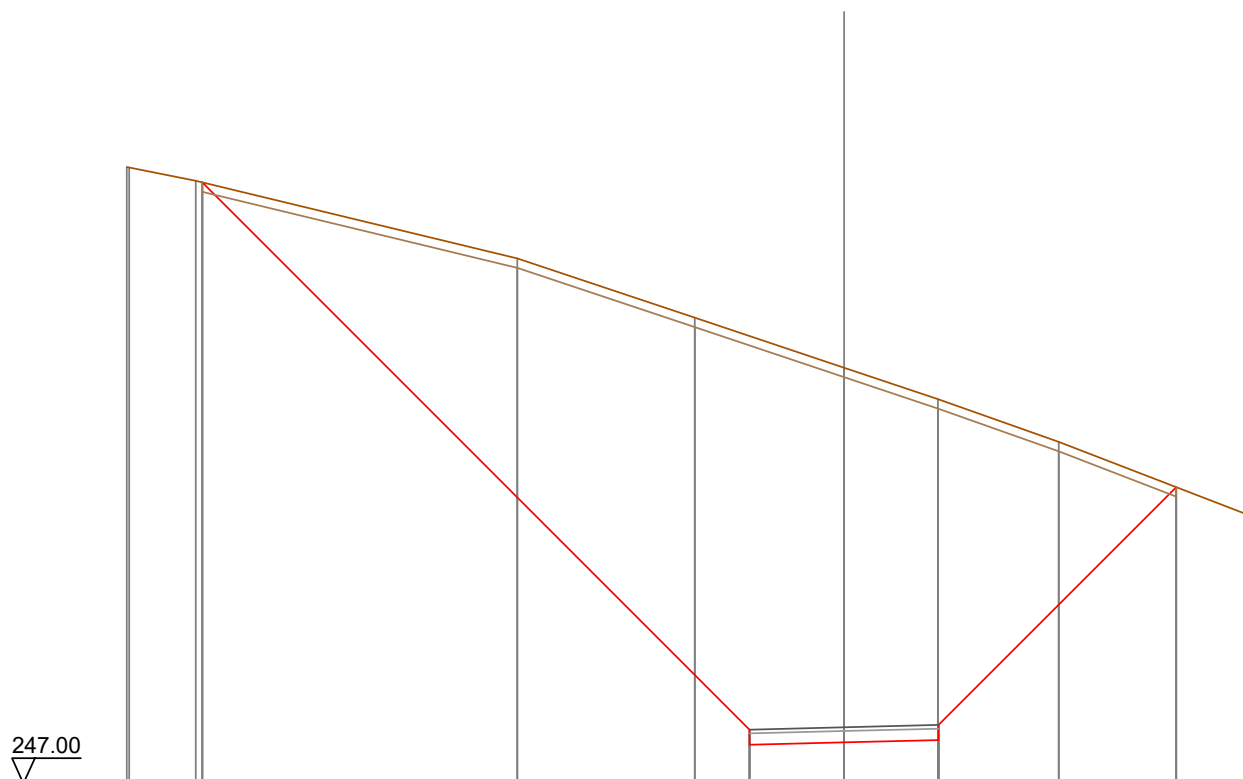

Quote Terreno	263.30 263.29	262.94	260.89	259.32	258.00	257.17	256.03	254.07
Quote Progetto		262.90		248.03	248.09	248.15		254.84
Parziali			14.47		2.50	2.50	6.29	
Progressiva		-16.97		-2.50	0.00	2.50		8.79
Dislivelli		0.00		-10.41	-9.91	-9.01		0.00

Sezione: 67
 Progressiva: 310.000
 Q. Progetto: 248.603

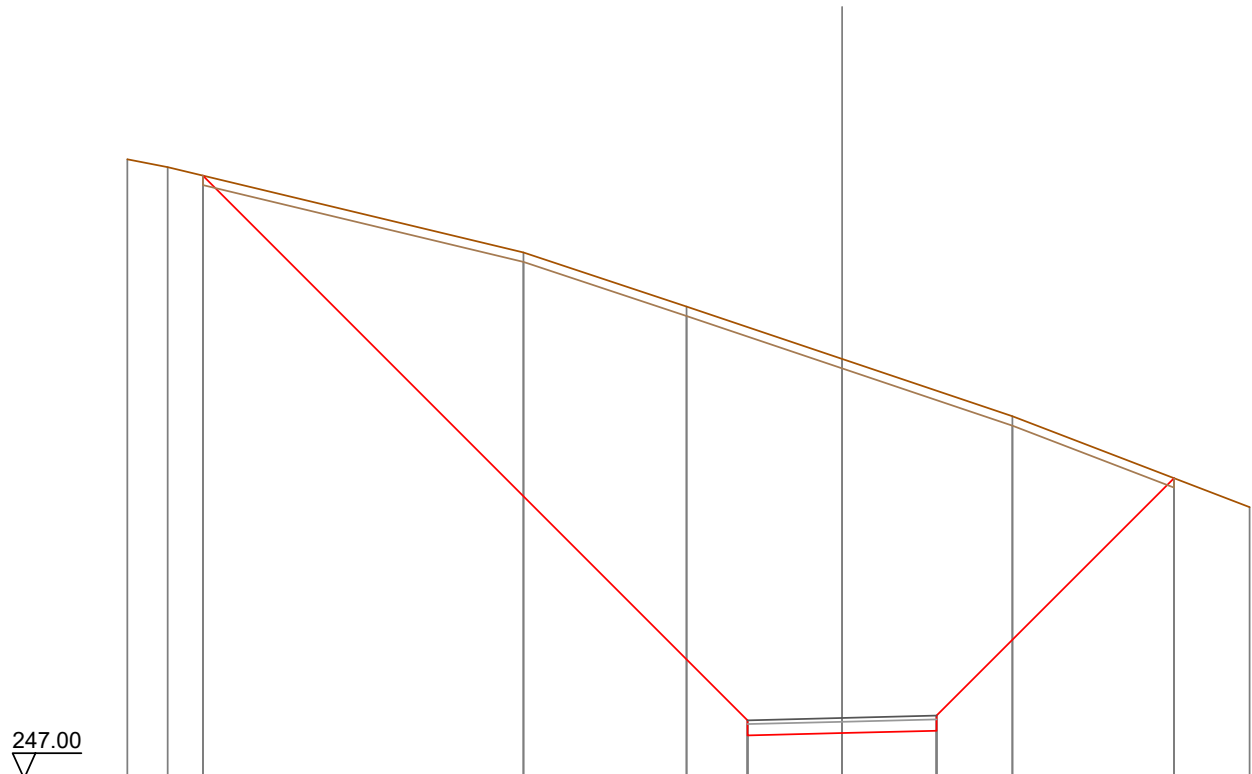

Quote Terreno	-263.38	-263.17	-260.91	-259.48	-258.10	-256.58	-254.18
Quote Progetto		262.95		248.14	248.20	248.27	254.95
Parziali			14.41		2.50	2.50	6.28
Progressiva		-16.91		-2.50	0.00	2.50	8.78
Dislivelli		0.00		-10.40	-9.90	-8.99	0.00

Sezione: 68
Progressiva: 312.767
Q. Progetto: 249.204

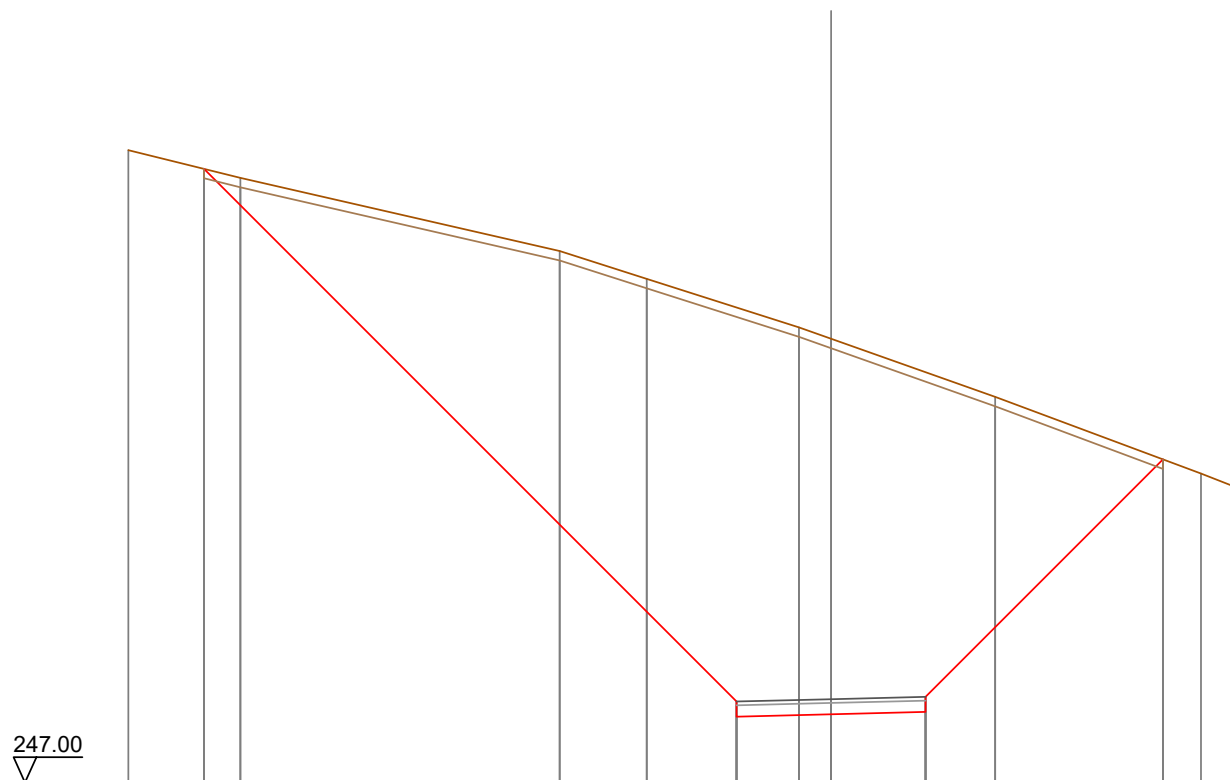

Quote Terreno	263.72	262.99		261.06	260.32	259.04	258.74	257.20	255.17	254.78
Quote Progetto		263.23				248.74	248.80	248.87	255.55	
Parziali			14.09			2.50	2.50	6.28		
Progressiva		-16.59				-2.50	0.00	2.50	8.78	
Dislivelli		-0.00				-10.42	-9.93	-8.98	0.00	

Sezione: 69
 Progressiva: 314.543
 Q. Progetto: 249.591

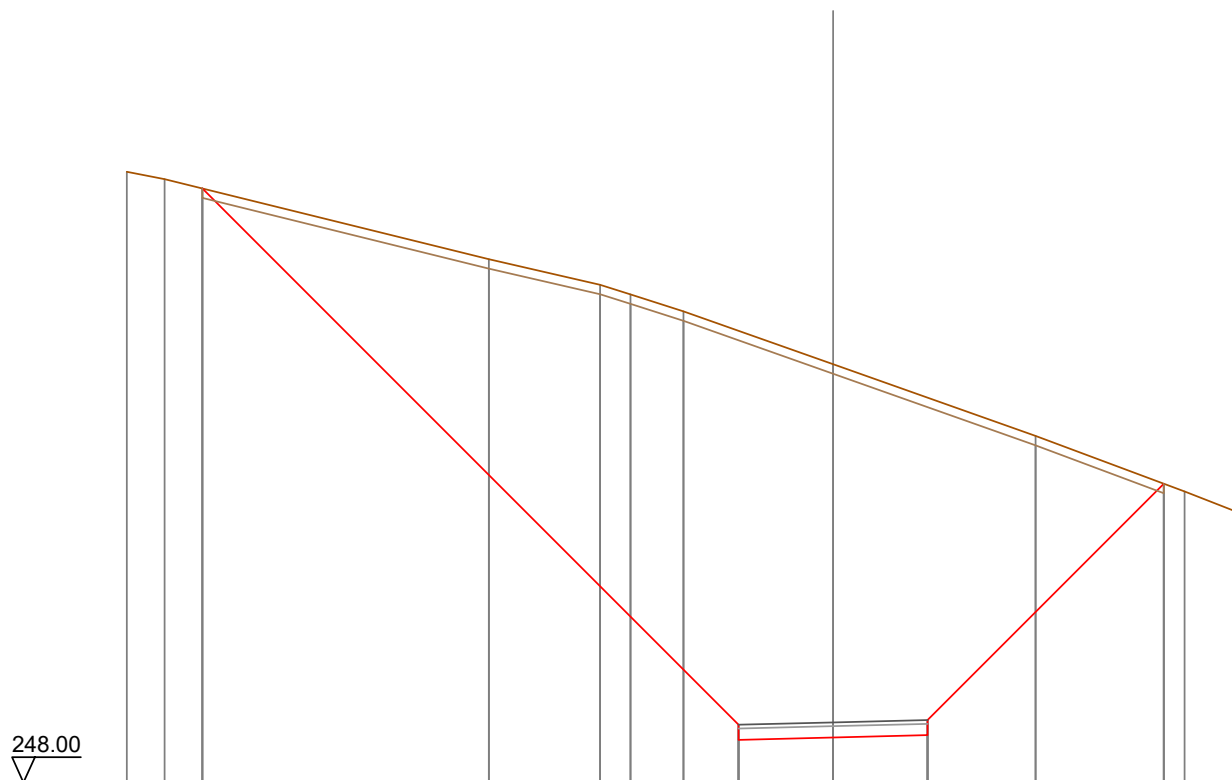

Quote Terreno	-264.15	-263.96	-261.84	-261.17	-260.91	-260.46	-259.06	-257.17	-255.70	-255.13
Quote Progetto		263.71				249.13	249.19	249.25	255.90	
Parziali			14.18			2.50	2.50		6.25	
Progressiva		-16.68				-2.50	0.00	2.50		8.75
Dislivelli		0.00				-10.42	-9.87	-8.92		-0.00

Sezione: 70
 Progressiva: 320.000
 Q. Progetto: 250.778

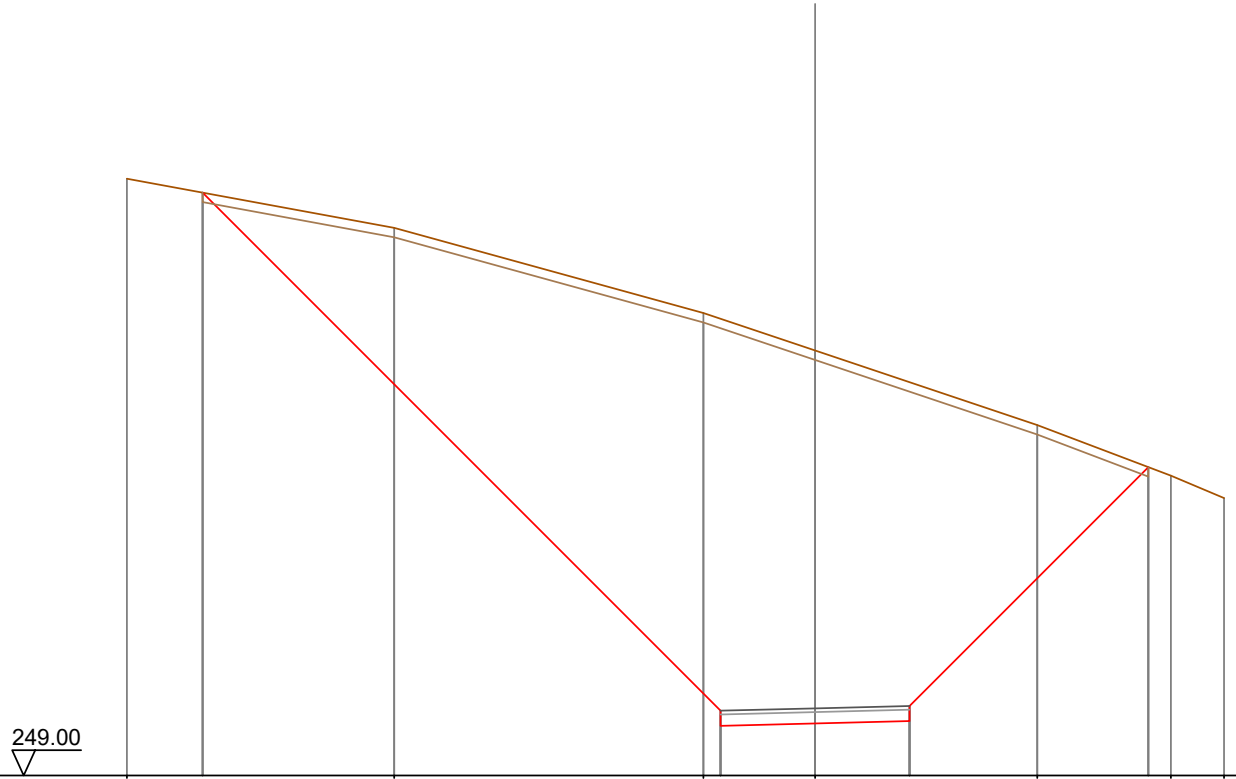

Quote Terreno		264.78		263.48		261.23		260.24		258.27		256.93		256.34
Quote Progetto		264.42				250.32		250.38		250.44		257.16		
Parziali			13.70			2.50		2.50		6.31				
Progressiva		-16.20				-2.50		0.00		2.50		8.81		
Dislivelli		-0.00				-10.37		-9.86		-8.96		0.00		

Sezione: 71
 Progressiva: 322.531
 Q. Progetto: 251.328

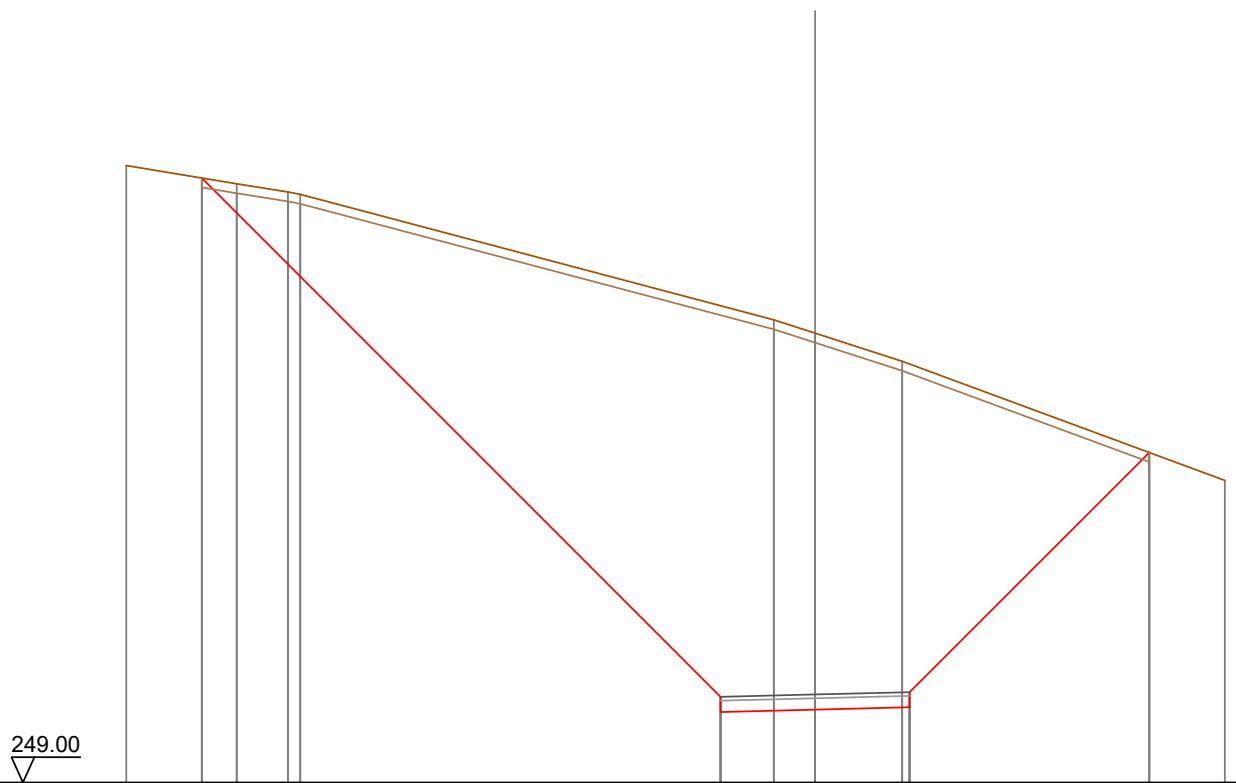

Quote Terreno	-265.32	-264.83	-264.62	-264.55	-250.87	-261.24	-260.89	-260.14	-256.99
Quote Progetto		264.99			250.87	250.93	250.89	250.99	257.73
Parziali			13.72		2.50	2.50		6.34	
Progressiva		-16.22			-2.50	0.00	2.50		8.84
Dislivelli		0.00			-10.34	-9.96	-9.08		0.00

Sezione: 72
 Progressiva: 330.000
 Q. Progetto: 252.953

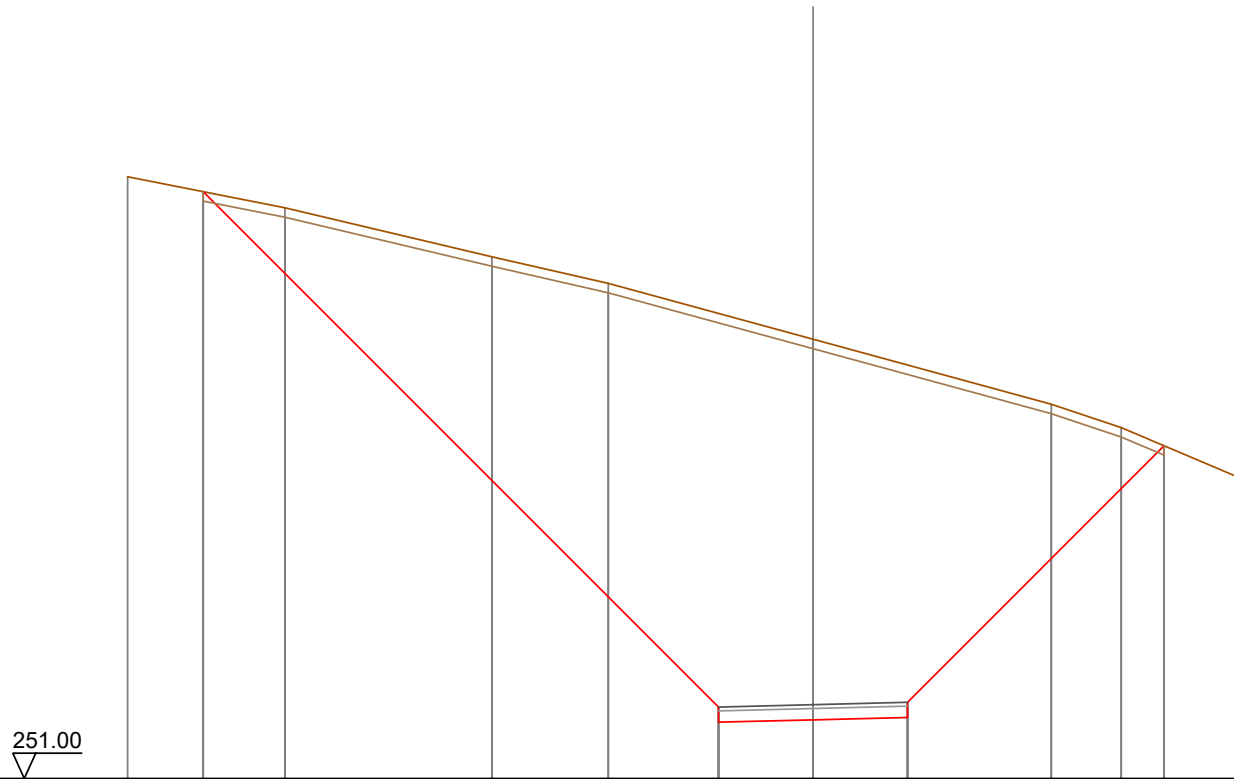

Quote Terreno		-266.92		-266.10		-264.80		-264.10		-262.62		-260.90		-260.28		-258.95
Quote Progetto			266.52					252.49		252.55		252.62				259.80
Parziali					13.63			2.50	2.50			6.79				
Progressiva			-16.13					-2.50	0.00	2.50					9.29	
Dislivelli			0.00					-10.41	-10.06	-9.32					0.00	

Sezione: 73
 Progressiva: 330.519
 Q. Progetto: 253.066

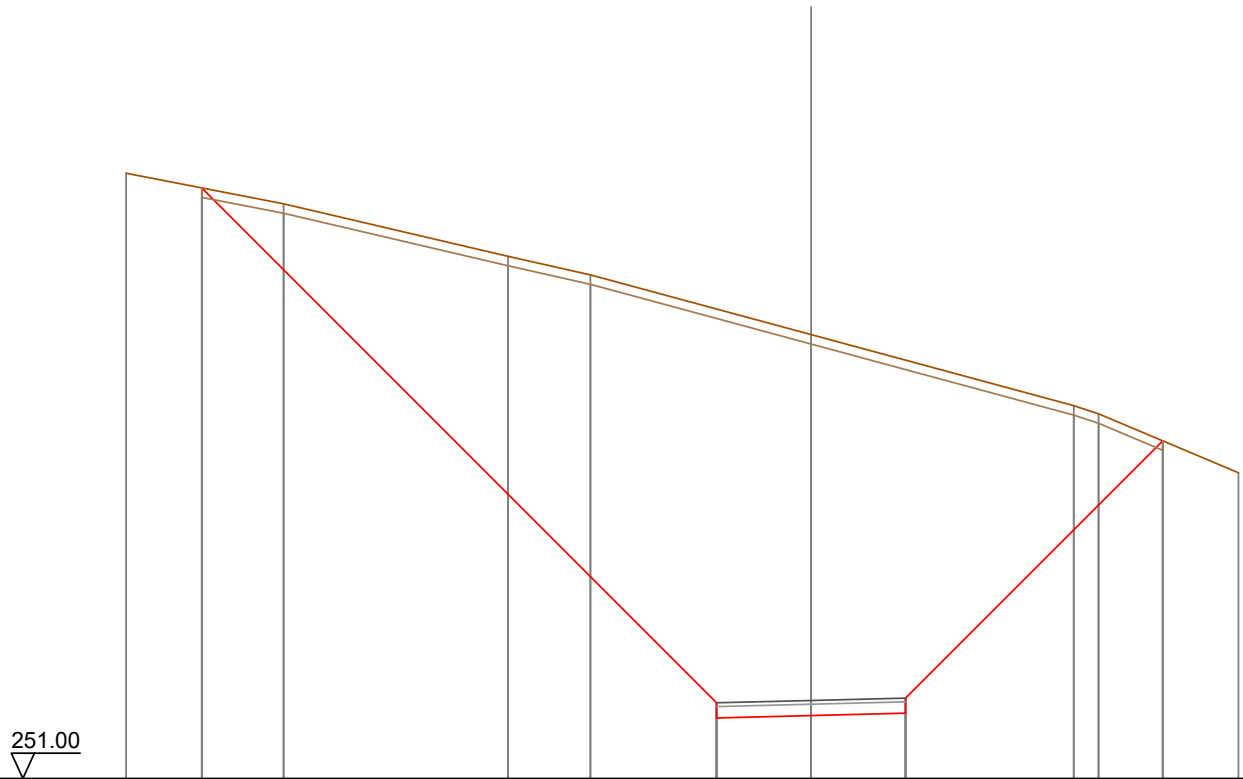

Quote Terreno	-267.01	-266.20	-264.81	-264.32	-252.60	-262.74	-260.86	-260.65	-259.09
Quote Progetto		266.62			252.60	252.67	252.73		259.93
Parziali			13.62		2.50	2.50	6.80		
Progressiva		-16.12			-2.50	0.00	2.50		9.30
Dislivelli		0.00			-10.42	-10.08	-9.34		0.00

Sezione: 74
 Progressiva: 336.425
 Q. Progetto: 254.351

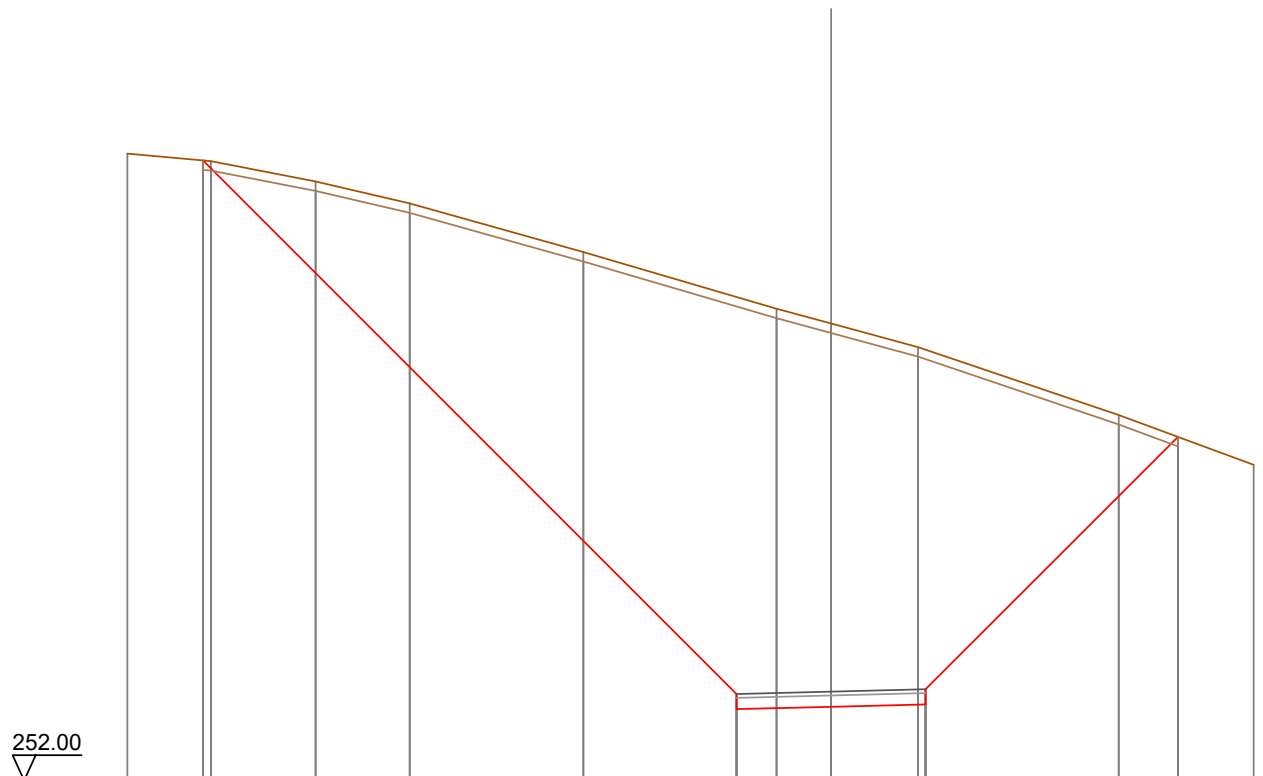

Quote Terreno	-268.58	-268.38	-267.84	-267.26	-265.98	-264.48	-264.09	-263.46	-261.67	-260.35
Quote Progetto		268.40				253.89	253.95	254.01		261.09
Parziali			14.11			2.50	2.50	6.68		
Progressiva		-16.61				-2.50	0.00	2.50		9.18
Dislivelli		0.00				-10.50	-10.14	-9.38		0.00

Sezione: 75
 Progressiva: 340.000
 Q. Progetto: 255.128

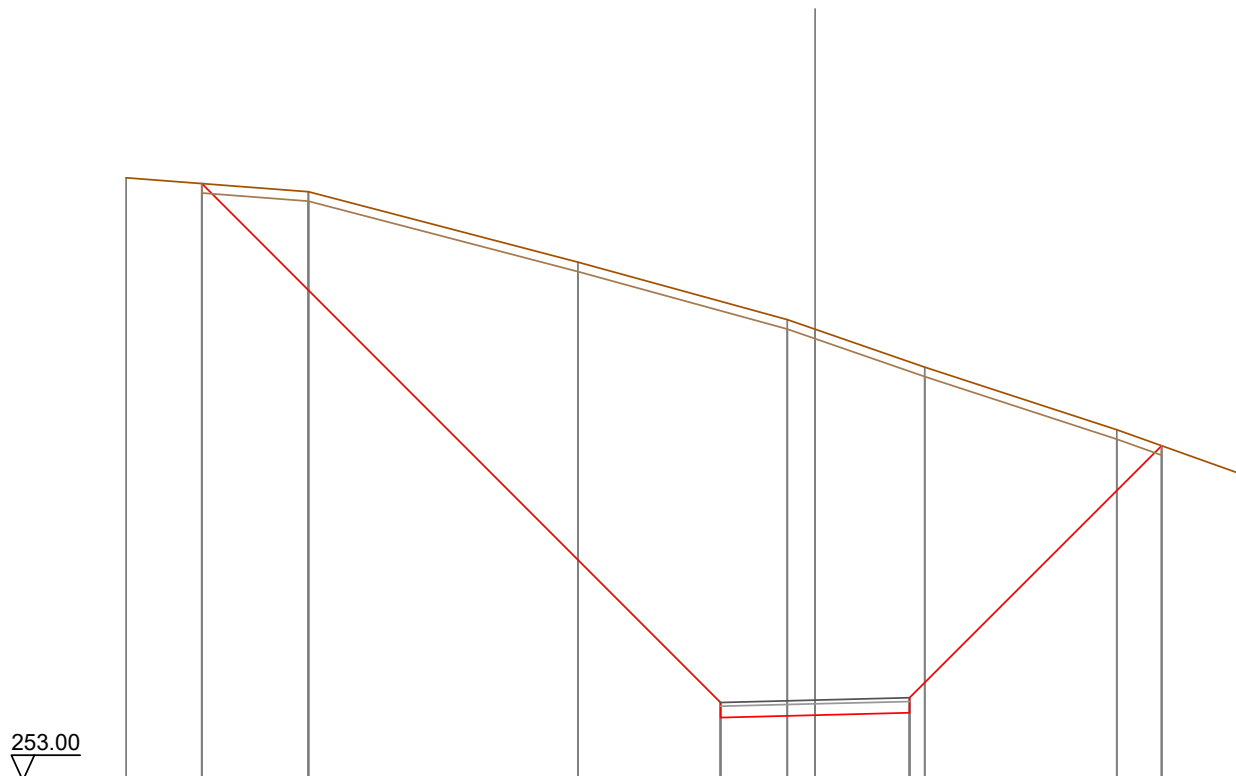

Quote Terreno	-268.94	-268.57	-266.71	-265.19	-264.93	-263.93	-262.28	-261.14
Quote Progetto		268.79		254.67	254.73	254.79		261.86
Parziali		13.72		2.50	2.50	6.67		
Progressiva		-16.22		-2.50	0.00	2.50		9.17
Dislivelli		0.00		-10.61	-10.21	-9.28		0.00

Sezione: 76
 Progressiva: 341.121
 Q. Progetto: 255.372

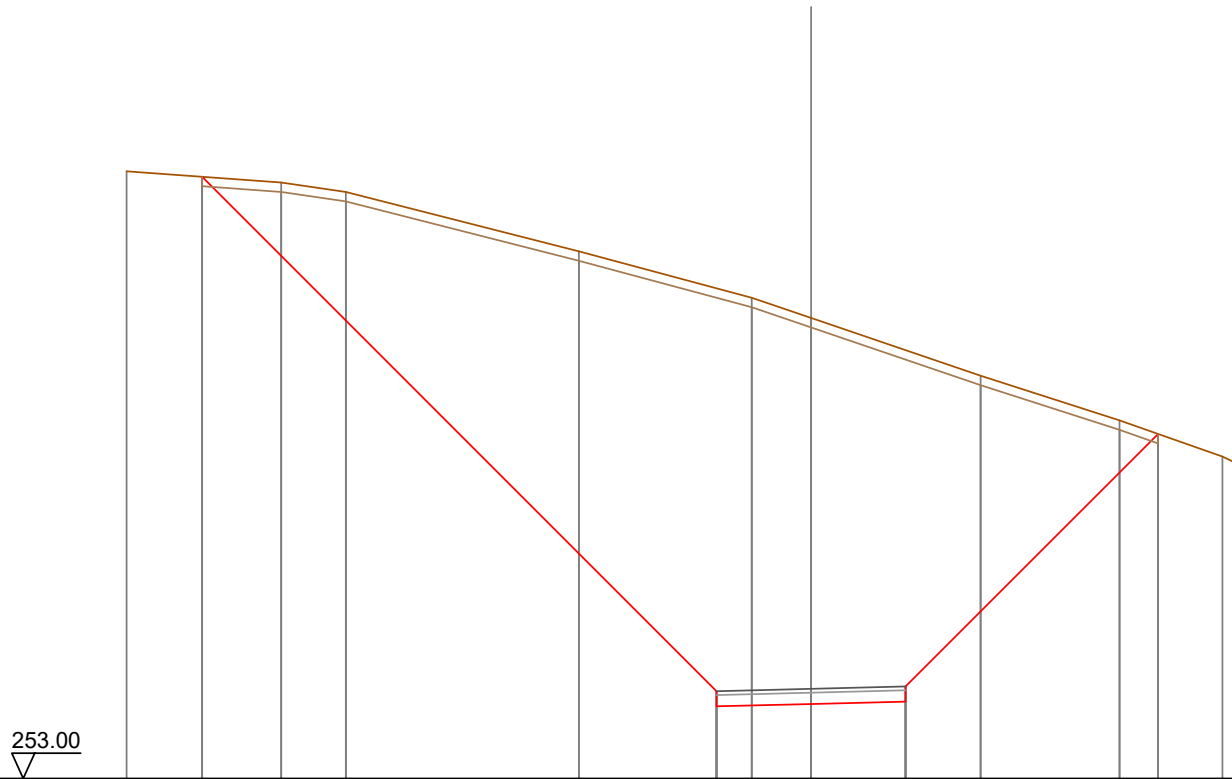

Quote Terreno	269.06	268.76	268.51	266.94	265.71	265.18	263.65	262.47	261.51	261.38
Quote Progetto	268.91				254.91	254.97	255.03		262.11	
Parziali		13.61			2.50	2.50	6.68			
Progressiva	-16.11				-2.50	0.00	2.50		9.18	
Dislivelli	0.00				-10.65	-10.21	-9.29		0.00	

Sezione: 77
 Progressiva: 345.817
 Q. Progetto: 256.393

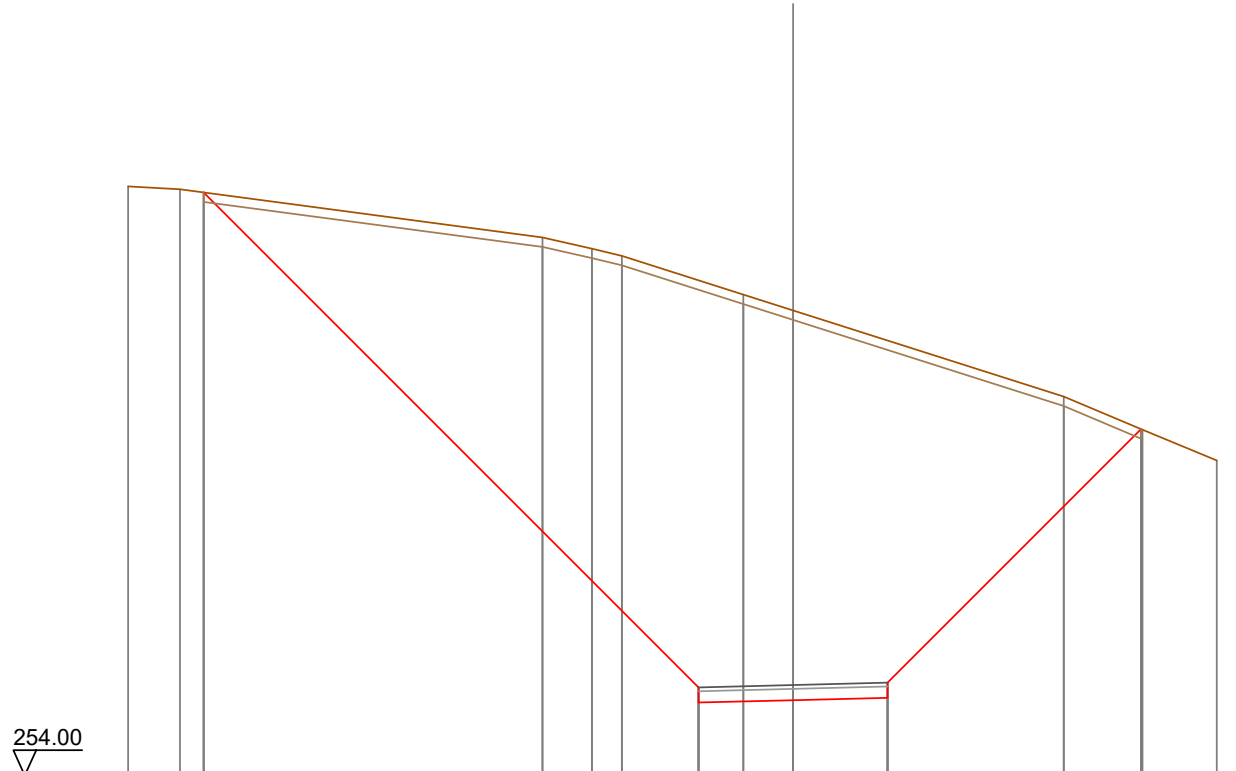

Quote Terreno		269.58	269.50		268.23	267.93	267.74		266.72	266.30		264.02	263.14	262.33
Quote Progetto			269.42						255.93	255.99	256.06		263.16	
Parziali				13.09					2.50	2.50		6.71		
Progressiva			-15.59						-2.50	0.00	2.50		9.21	
Dislivelli			0.00						-10.77	-10.31	-9.45		0.00	

Sezione: 78
 Progressiva: 354.999
 Q. Progetto: 258.390

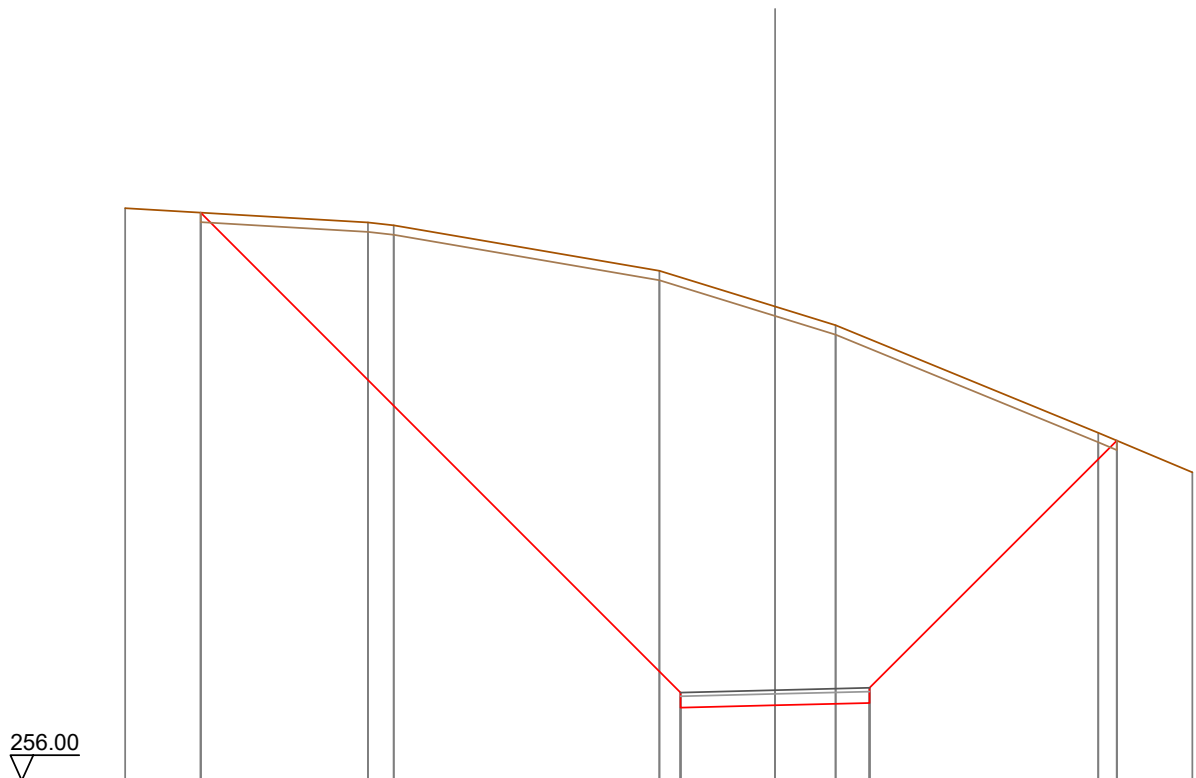

Quote Terreno	-271.14	-270.76	-270.68	-269.48	-268.54	-268.04	-265.20	-264.15
Quote Progetto		271.02		257.93	257.99	258.05	264.99	
Parziali			12.69	2.50	2.50	6.54		
Progressiva		-15.19		-2.50	0.00	2.50	9.04	
Dislivelli		0.00		-10.98	-10.55	-9.62	-0.00	

Sezione: 79
 Progressiva: 358.463
 Q. Progetto: 259.144

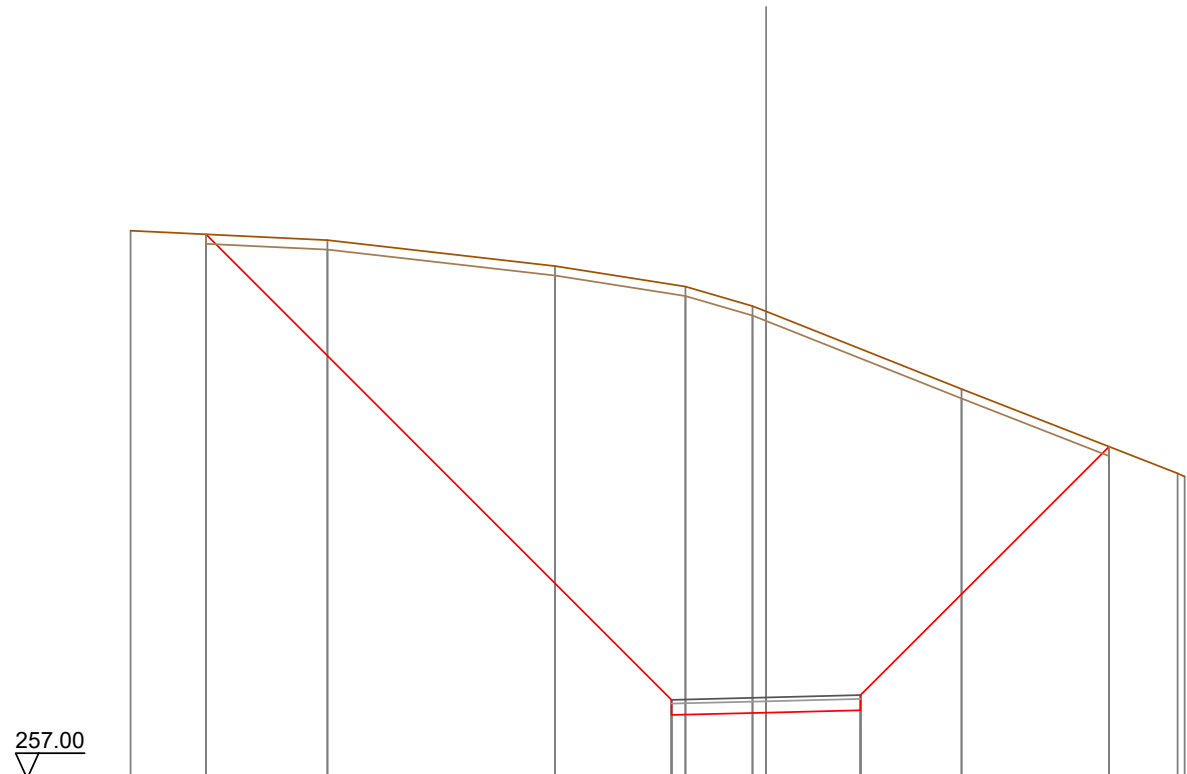

Quote Terreno	271.49	271.24	270.55	270.01	269.50	269.35	267.30	265.07	264.98
Quote Progetto		271.39		258.68	258.74	258.81		265.78	
Parziali			12.31		2.50	2.50	6.57		
Progressiva		-14.81		-2.50	0.00	2.50		9.07	
Dislivelli		0.00		-10.99	-10.61	-9.55		0.00	

Sezione: 80
 Progressiva: 360.000
 Q. Progetto: 259.478

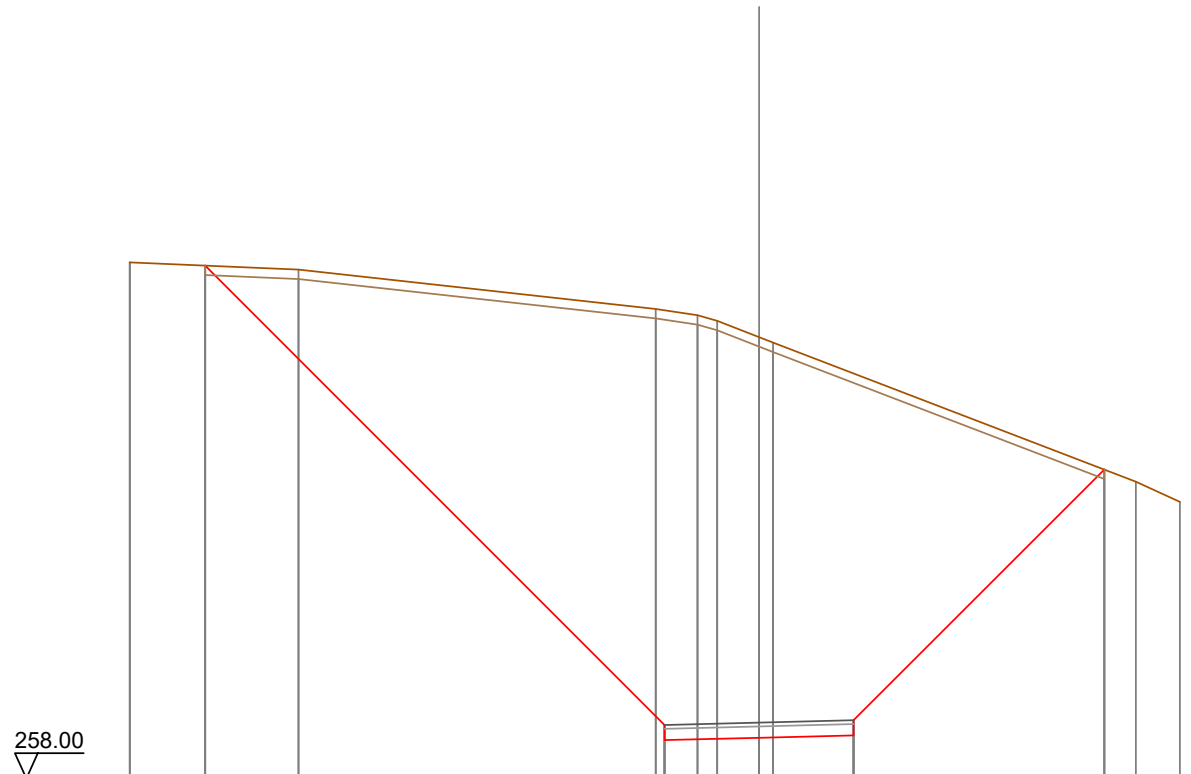

Quote Terreno	-271.65	-271.46	-270.42	-270.25	-270.11	-269.67	-269.53	-266.85	-265.32
Quote Progetto		271.56	259.02			259.08		259.14	266.17
Parziali		12.15	2.50	2.50	6.63				
Progressiva		-14.65	-2.50	0.00	2.50	9.13			
Dislivelli		0.00	-10.97	-10.60	-9.57	0.00			

Sezione: 81
 Progressiva: 361.927
 Q. Progetto: 259.897

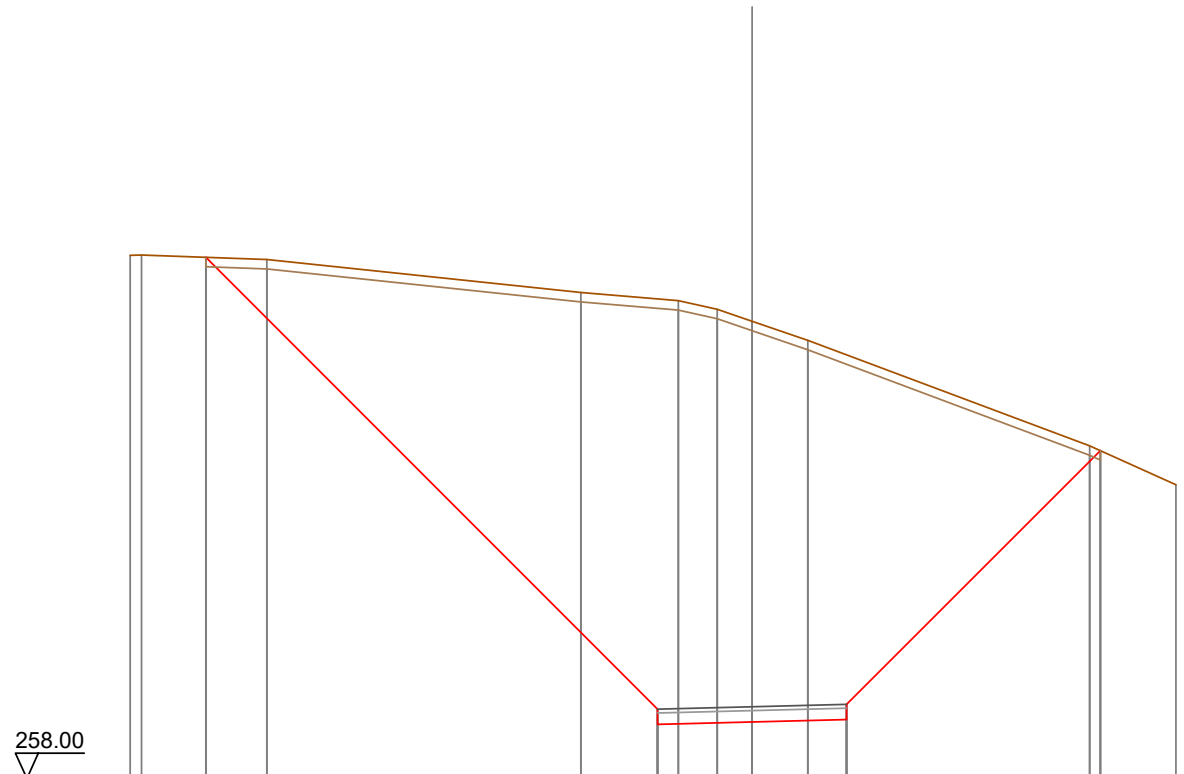

Quote Terreno	271.83	271.85	271.73	270.86	270.64	270.41	270.09	269.59	266.80	265.77
Quote Progetto		271.78			259.43	259.50	259.56		266.67	
Parziali			11.95		2.50	2.50	6.71			
Progressiva		-14.45			-2.50	0.00	2.50		9.21	
Dislivelli		-0.00			-10.85	-10.60	-9.64		0.00	

Sezione: 82
 Progressiva: 367.564
 Q. Progetto: 261.124

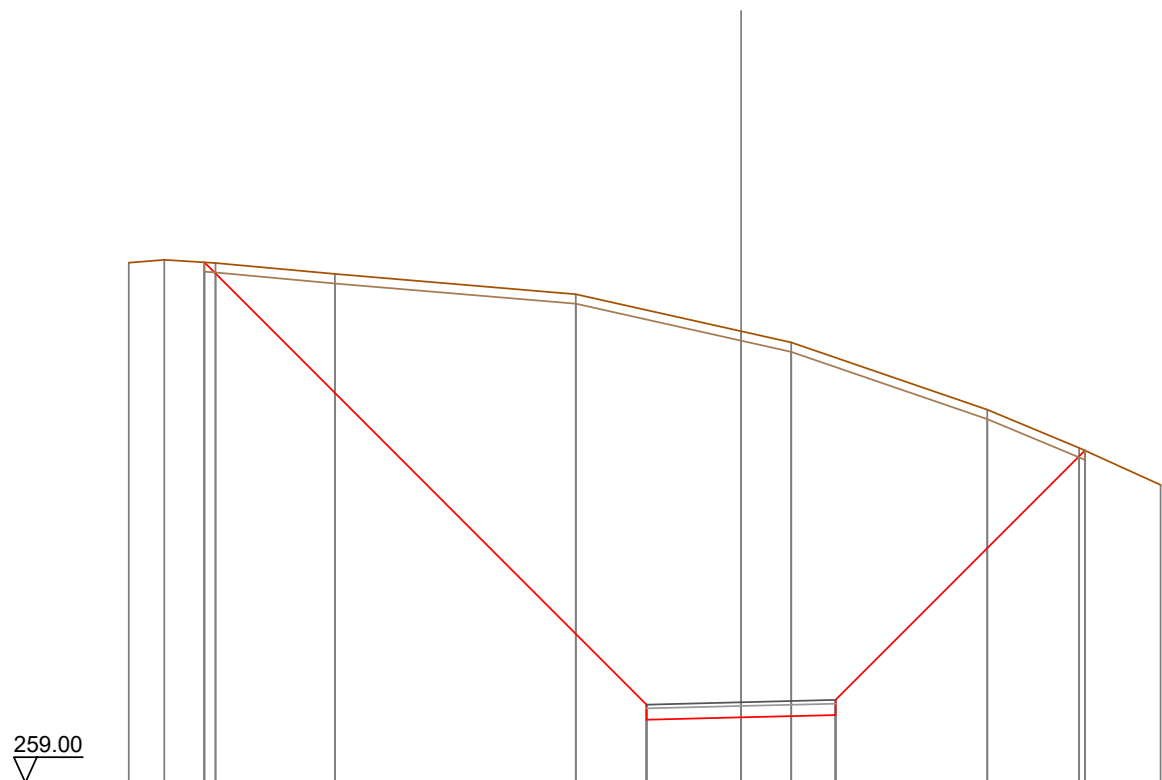

Quote Terreno	-272.75	-272.82	-272.74	-272.45	-271.91	-260.66	-270.94	-270.64	-268.86	-267.85	-266.87
Quote Progetto			272.76			260.66	260.72	270.94		267.78	
Parziali				11.70		2.50	2.50		6.59		
Progressiva			-14.20			-2.50	0.00	2.50		9.09	
Dislivelli			-0.00			-10.43	-10.21	-9.45		0.00	

Sezione: 83
 Progressiva: 370.000
 Q. Progetto: 261.653

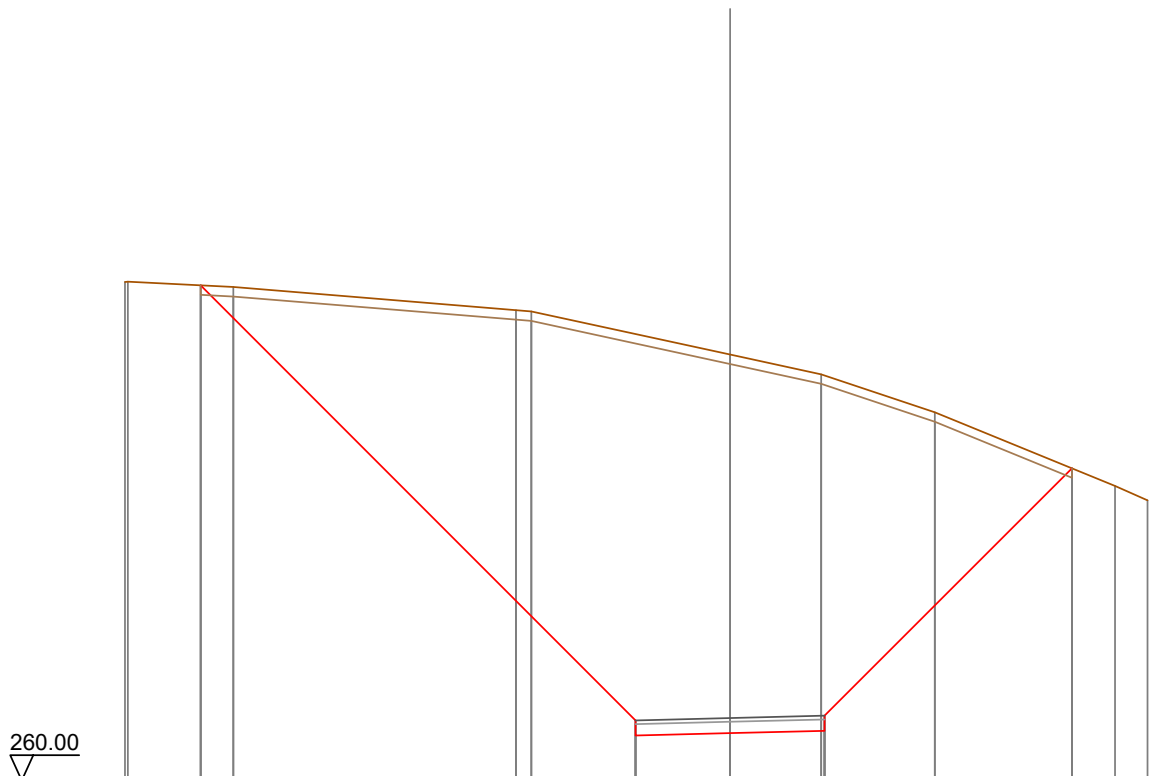

Quote Terreno	273.18 273.19	273.05	272.44 272.41	261.19	261.25 271.26	261.32 270.74	268.74	267.79 267.41
Quote Progetto		273.09		261.19	261.25	261.32		268.26
Parziali			11.50	2.50	2.50		6.54	
Progressiva		-14.00		-2.50	0.00	2.50		9.04
Dislivelli		0.00		-10.22	-10.01	-9.39		0.00

Sezione: 84
 Progressiva: 372.255
 Q. Progetto: 262.144

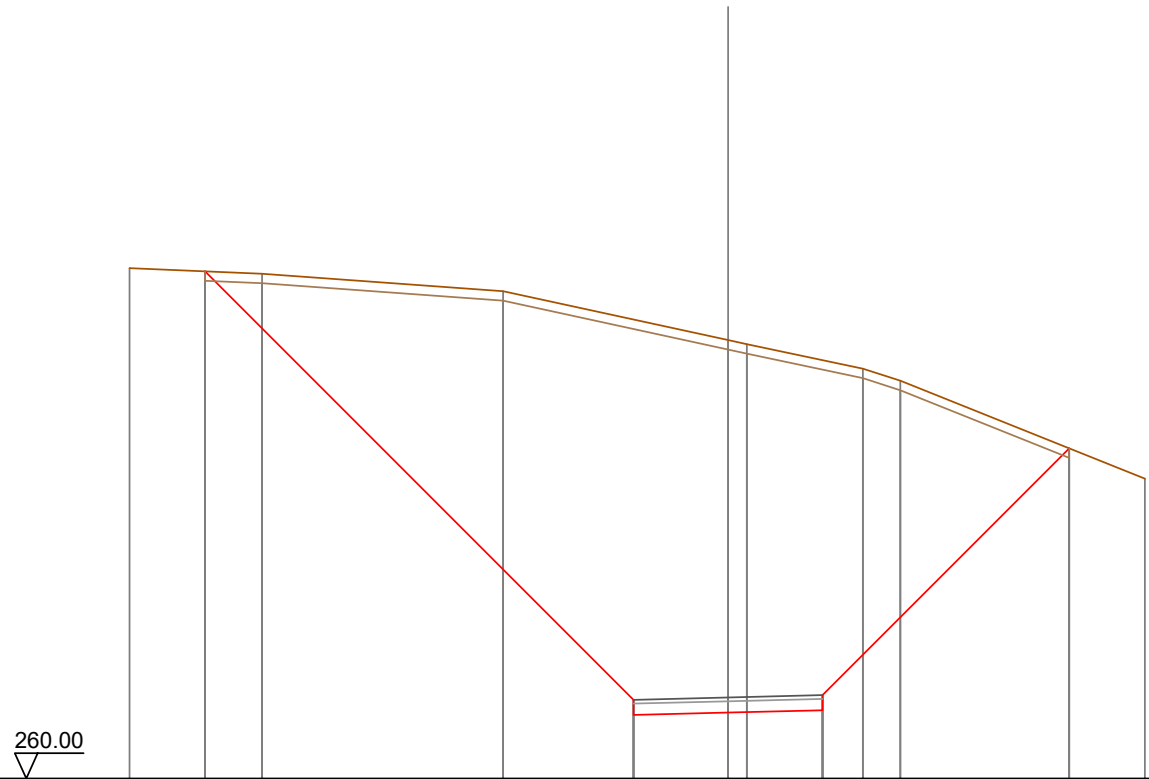

Quote Terreno	-273.50	-273.35	-272.89	-261.68	-271.60	-271.49	-270.84	-270.52	-267.93
Quote Progetto		273.41		261.68	261.74	271.49	261.81		268.73
Parziali		11.33		2.50	2.50		6.52		
Progressiva		-13.83		-2.50	0.00	2.50			9.02
Dislivelli		0.00		-10.06	-9.85	-9.26			0.00

Sezione: 85
 Progressiva: 376.946
 Q. Progetto: 263.164

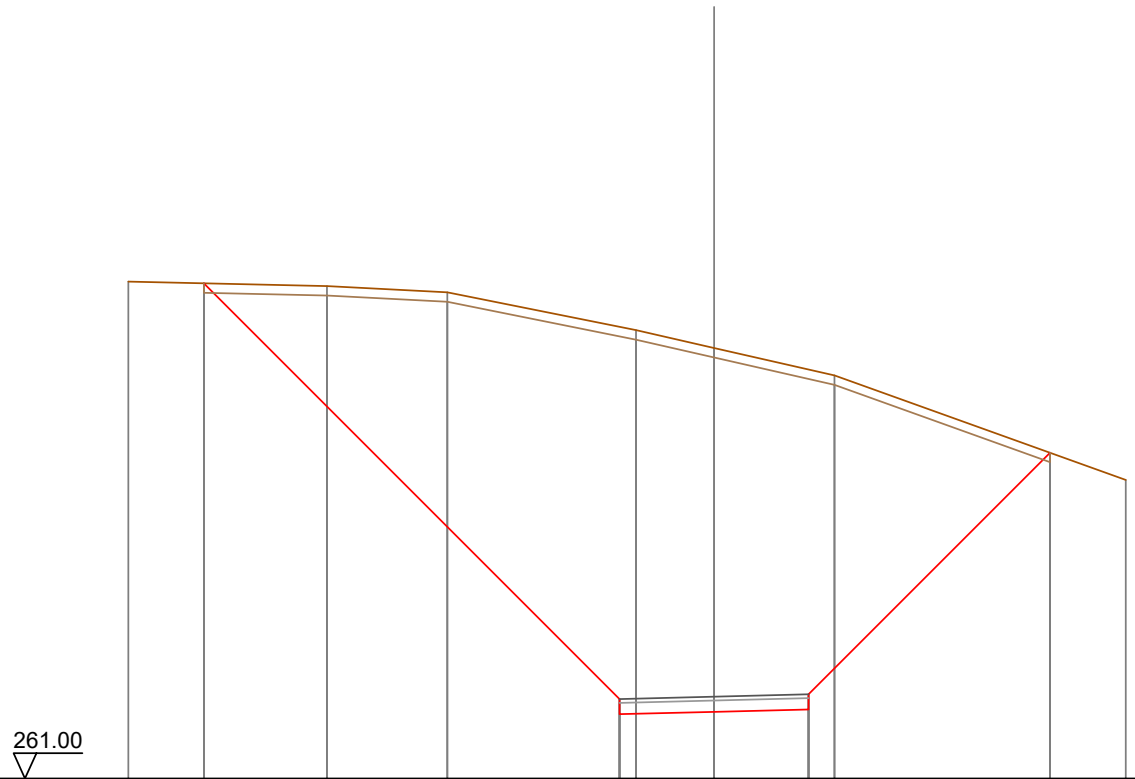

Quote Terreno	-274.14	-274.02	-273.86	-272.86	-272.39	-271.66	-268.90
Quote Progetto	274.10			262.70	262.76	262.83	269.62
Parziali		10.99		2.50	2.50	6.39	
Progressiva	-13.49			-2.50	0.00	2.50	8.89
Dislivelli	0.00			-9.84	-9.62	-8.99	0.00

Sezione: 86
 Progressiva: 380.000
 Q. Progetto: 263.829

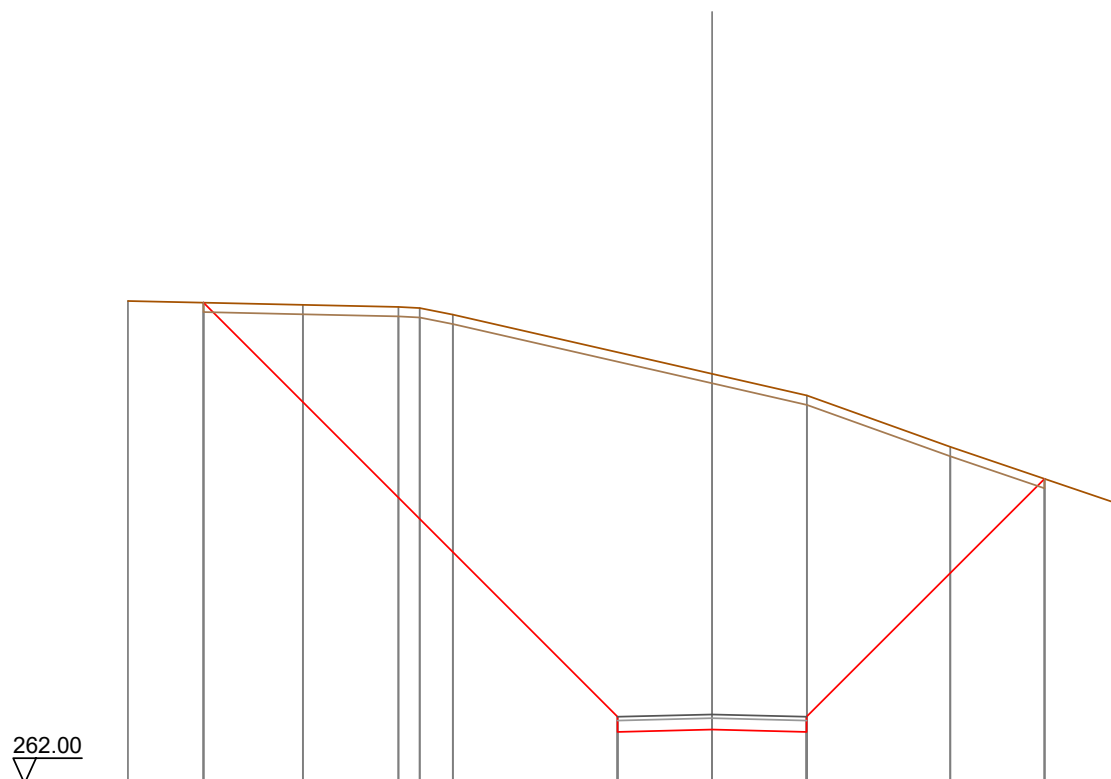

Quote Terreno	-274.76	-274.66	-274.60	-274.58	-274.40	-263.37	-272.84	-272.27	-270.91	-270.06	-269.38
Quote Progetto		274.72				263.37	263.43	263.37		270.06	
Parziali			10.95			2.50	2.50		6.29		
Progressiva		-13.45				-2.50	0.00	2.50		8.79	
Dislivelli		0.00				-9.64	-9.41	-8.90		-0.00	

Sezione: 87
 Progressiva: 400.000
 Q. Progetto: 268.179

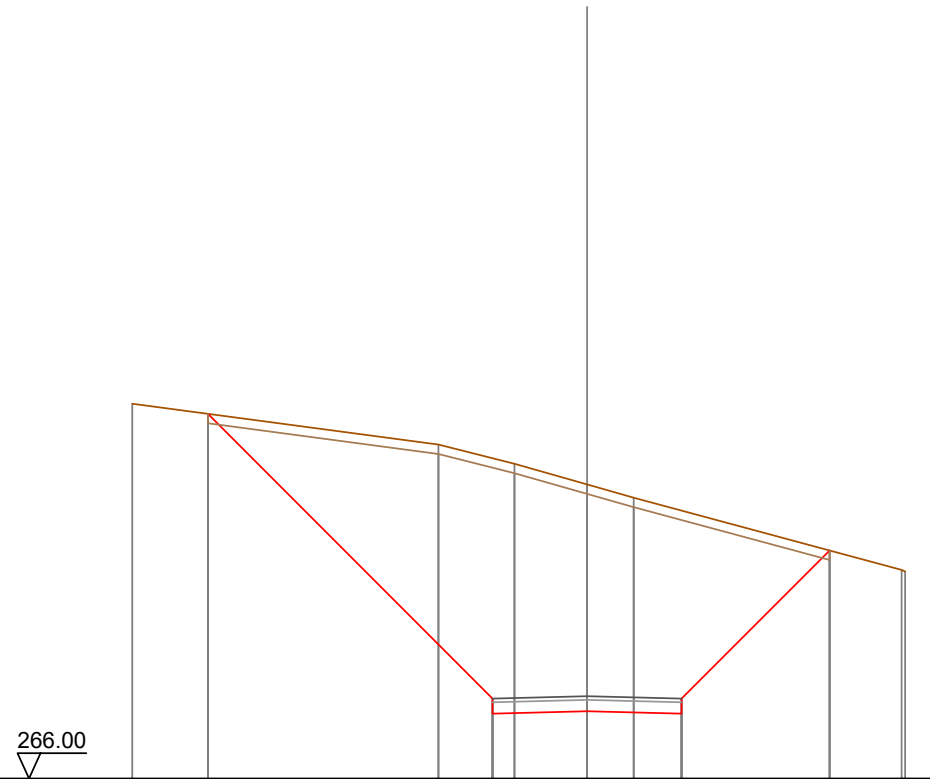

Quote Terreno		-275.91		-274.83	-274.33	-273.78	-273.43		-271.52	-271.48
Quote Progetto			275.65		267.72	267.78		267.72		272.03
Parziali				7.53		2.50	2.50		3.91	
Progressiva			-10.03		-2.50	0.00		2.50		6.41
Dislivelli			-0.00		-6.36	-6.00		-5.37		0.00

Sezione: 88
 Progressiva: 416.917
 Q. Progetto: 271.859

270.00

Quote Terreno	-274.90	-274.80	-273.79	-273.38	-272.15	-271.89
Quote Progetto		274.70	271.52	271.46	271.40	272.51
Parziali		2.78	2.50	2.50	0.72	
Progressiva		-5.28	-2.50	0.00	2.50	3.22
Dislivelli		0.00	-2.11	-1.92	-1.31	0.00

Sezione: 89
 Progressiva: 420.000
 Q. Progetto: 272.529

271.00

Quote Terreno	-275.09			-273.50	-273.42	-272.46	-272.09
Quote Progetto		274.60	272.19	272.13	272.07	272.75	
Parziali		2.01	2.50	2.50	0.28		
Progressiva		-4.51	-2.50	0.00	2.50	2.79	
Dislivelli		-0.00	-1.52	-1.37	-0.76	0.00	

Sezione: 90
 Progressiva: 420.421
 Q. Progetto: 272.621

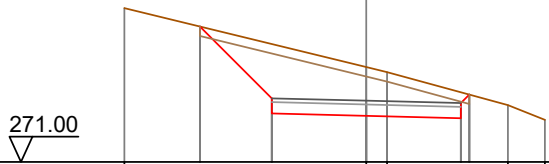

Quote Terreno	-275.07			273.51	273.38		272.50	272.11
Quote Progetto		274.58	272.28	272.22		272.16	272.78	
Parziali			1.90	2.50	2.50			
Progressiva		-4.40	-2.50	0.00		2.50	2.72	
Dislivelli		0.00	-1.44	-1.29		-0.69	0.00	

Sezione: 91
 Progressiva: 423.925
 Q. Progetto: 273.376

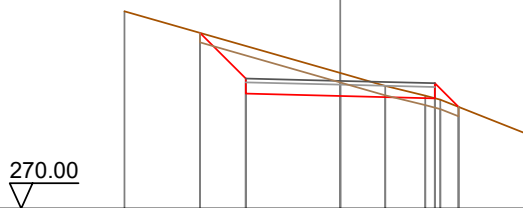

Quote Terreno	-275.22			273.59	273.25		272.99	272.88	271.90
Quote Progetto		274.65	273.04	272.98		272.91	272.88	272.69	
Parziali			1.21	2.50	2.50		0.63		
Progressiva		-3.71	-2.50	0.00		2.50	3.13		
Dislivelli		-0.00	-0.86	-0.61		-0.00	0.00		

Sezione: 92
 Progressiva: 440.000
 Q. Progetto: 276.511

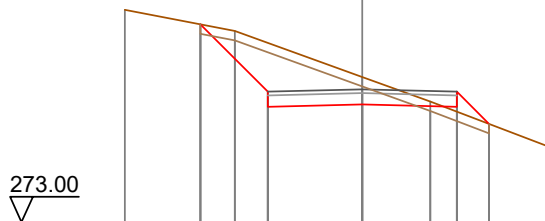

Quote Terreno	-278.61			276.84	276.19			274.83
Quote Progetto		278.23	276.05	276.11	276.05		275.60	
Parziali			1.78	2.50	2.50		0.85	
Progressiva		-4.28	-2.50	0.00		2.50	3.35	
Dislivelli		-0.00	-1.29	-0.73		0.13	0.00	

Sezione: 93
 Progressiva: 460.000
 Q. Progetto: 279.656

277.00

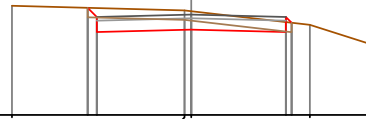

Quote Terreno	-279.89		279.77	279.75		279.39	-278.90
Quote Progetto		279.83	279.19	279.26	279.19	279.44	
Parziali			2.50	2.50			
Progressiva		-2.74	-2.50	0.00	2.50	2.65	
Dislivelli		0.00	-0.23	-0.49	-0.26	0.00	

Sezione: 94
 Progressiva: 467.682
 Q. Progetto: 280.645

278.00

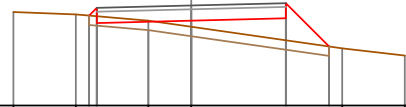

Quote Terreno	-280.47	280.41	-280.25	280.08		279.51	-279.32
Quote Progetto		280.38	280.18	280.25	280.31	279.56	
Parziali			2.50	2.50	1.15		
Progressiva		-2.70	-2.50	0.00	2.50	3.65	
Dislivelli		-0.00	0.22	0.16	0.58	0.00	

Sezione: 95
 Progressiva: 469.094
 Q. Progetto: 280.814

278.00

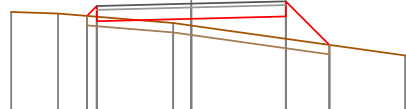

Quote Terreno	280.60	280.55	280.30	280.24			279.44
Quote Progetto		280.49	280.35	280.41	280.48	279.72	
Parziali			2.50	2.50	1.15		
Progressiva		-2.76	-2.50	0.00	2.50	3.65	
Dislivelli		0.00	0.28	0.18	0.59	0.00	

Sezione: 96
 Progressiva: 470.000
 Q. Progetto: 280.920

278.00

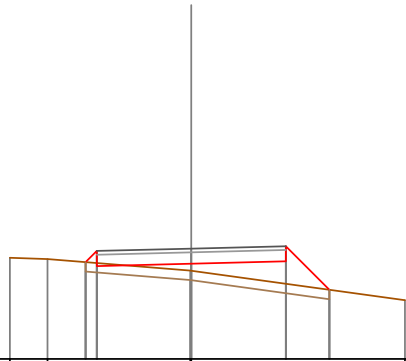

Quote Terreno	-280.68	-280.64	280.34	280.33	-279.55
Quote Progetto		280.56	280.52	280.58	279.83
Parziali		0.28	2.50	2.50	1.15
Progressiva		-2.79	-2.50	0.00	2.50
Dislivelli		-0.00	0.32	0.18	0.59
					0.00

Sezione: 97
 Progressiva: 470.506
 Q. Progetto: 280.978

278.00

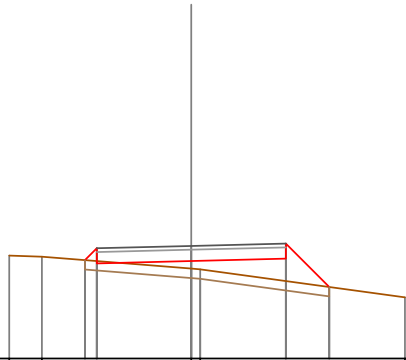

Quote Terreno	-280.72	-280.69	280.58	280.56	-279.62
Quote Progetto		280.60	280.56	280.64	279.89
Parziali		0.31	2.50	2.50	1.15
Progressiva		-2.81	-2.50	0.00	2.50
Dislivelli		-0.00	0.34	0.20	0.59
					0.00

Sezione: 98
 Progressiva: 480.000
 Q. Progetto: 281.979

279.00

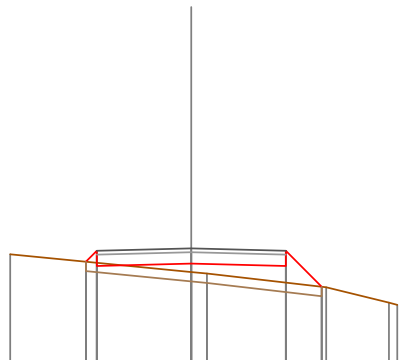

Quote Terreno	-281.83	281.63	281.36	281.32	280.95
Quote Progetto		281.52	281.58	281.52	280.97
Parziali		0.28	2.50	2.50	0.95
Progressiva		-2.79	-2.50	0.00	2.50
Dislivelli		-0.00	0.31	0.22	0.44
					-0.00

Sezione: 99
 Progressiva: 495.667
 Q. Progetto: 283.231

280.00

Quote Terreno	-284.10	-283.63	-283.48	-283.15	-282.90	-281.61
Quote Progetto		283.73	282.77	282.83	282.89	282.17
Parziali		0.56	2.50	2.50	1.13	
Progressiva		-3.06	-2.50	0.00	2.50	3.63
Dislivelli		-0.00	-0.46	-0.32	0.41	-0.00

Sezione: 100
 Progressiva: 498.182
 Q. Progetto: 283.386

280.00

Quote Terreno	-284.66	-284.27	-283.89	-283.33	-282.75	-281.77
Quote Progetto		284.28	282.92	282.99	283.05	282.32
Parziali		0.96	2.50	2.50	1.12	
Progressiva		-3.46	-2.50	0.00	2.50	3.62
Dislivelli		0.00	-0.70	-0.35	0.42	0.00

Sezione: 101
 Progressiva: 500.000
 Q. Progetto: 283.490

280.00

Quote Terreno	-285.00	-284.17	-283.50	-283.15	-281.97	
Quote Progetto		284.47	283.03	283.09	282.52	
Parziali		1.04	2.50	2.50	1.03	
Progressiva		-3.54	-2.50	0.00	2.50	3.53
Dislivelli		0.00	-0.77	-0.41	0.34	0.00

Sezione: 102
 Progressiva: 500.697
 Q. Progetto: 283.528

281.00

Quote Terreno	-285.07	-284.28	-283.57	-282.06		
Quote Progetto		284.55	283.07	283.13	283.19	282.61
Parziali		1.08	2.50	2.50	0.98	
Progressiva		-3.56	-2.50	0.00	2.50	3.48
Dislivelli		-0.00	-0.80	-0.44	0.31	0.00

Sezione: 103
 Progressiva: 505.158
 Q. Progetto: 283.749

281.00

Quote Terreno	-285.63	-284.98	-284.29	-283.99	-282.27	
Quote Progetto		285.11	283.29	283.35	283.41	282.90
Parziali		1.42	2.50	2.50	0.91	
Progressiva		-3.92	-2.50	0.00	2.50	3.41
Dislivelli		0.00	-1.03	-0.64	0.22	0.00

Sezione: 104
 Progressiva: 507.762
 Q. Progetto: 283.860

281.00

Quote Terreno	-285.93	-285.51	-285.34	-285.19	-284.32	-284.11	-282.41
Quote Progetto		285.41	283.40	283.46	283.52	283.04	
Parziali		1.61	2.50	2.50	0.88		
Progressiva		-4.11	-2.50	0.00	2.50	3.38	
Dislivelli		0.00	-1.09	-0.65	0.20	0.00	

Sezione: 105
 Progressiva: 510.000
 Q. Progetto: 283.944

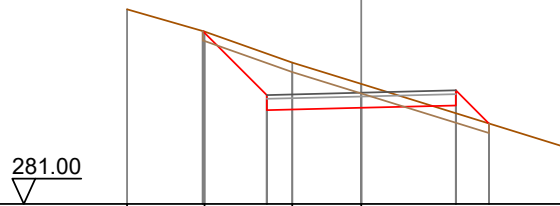

Quote Terreno	-286.15	-285.56	-284.74	-284.18	-282.51
Quote Progetto		285.57	283.48	283.54	283.61
Parziali		1.69	2.50	2.50	0.88
Progressiva		-4.19	-2.50	0.00	2.50
Dislivelli		0.00	-1.10	-0.63	0.21

Sezione: 106
 Progressiva: 510.365
 Q. Progetto: 283.957

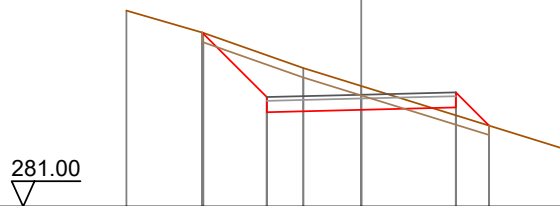

Quote Terreno	-286.18	-285.60	-284.66	-284.19	-282.52
Quote Progetto		285.60	283.49	283.56	283.62
Parziali		1.71	2.50	2.50	0.88
Progressiva		-4.21	-2.50	0.00	2.50
Dislivelli		0.00	-1.11	-0.63	0.21

Sezione: 107
 Progressiva: 520.000
 Q. Progetto: 284.303

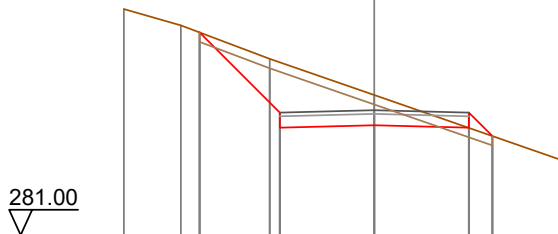

Quote Terreno	-286.98	-286.55	-285.66	-284.70	-282.99
Quote Progetto		286.36	283.84	283.90	283.84
Parziali		2.12	2.50	2.50	0.62
Progressiva		-4.62	-2.50	0.00	2.50
Dislivelli		-0.00	-1.33	-0.80	0.01

Sezione: 108
 Progressiva: 532.280
 Q. Progetto: 284.745

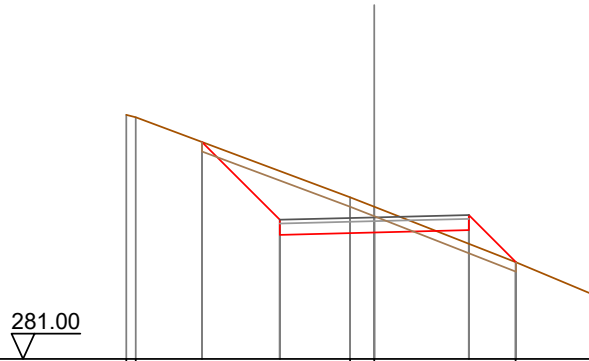

Quote Terreno	-287.46	-287.39		-285.28	-285.03		-283.56	-282.72
Quote Progetto		286.74	284.28	284.34	284.41	283.56		
Parziali			2.06	2.50	2.50	1.25		
Progressiva		-4.56	-2.50	0.00	2.50	3.75		
Dislivelli		-0.00	-1.29	-0.68	0.36	0.00		

Sezione: 109
 Progressiva: 540.000
 Q. Progetto: 285.023

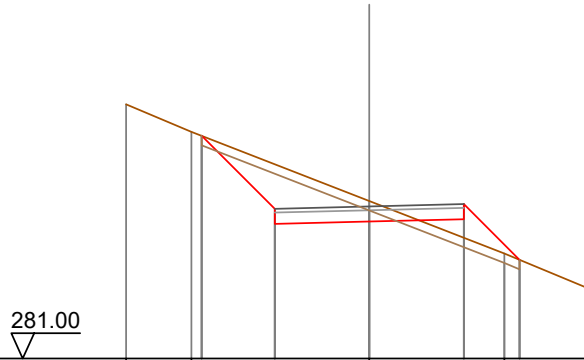

Quote Terreno	-287.72	-287.00		-285.17		-283.78	-282.78
Quote Progetto		286.89	284.56	284.62	284.69	283.61	
Parziali			1.93	2.50	2.50	1.48	
Progressiva		-4.43	-2.50	0.00	2.50	3.98	
Dislivelli		-0.00	-1.18	-0.54	0.49	0.00	

Sezione: 110
 Progressiva: 542.040
 Q. Progetto: 285.096

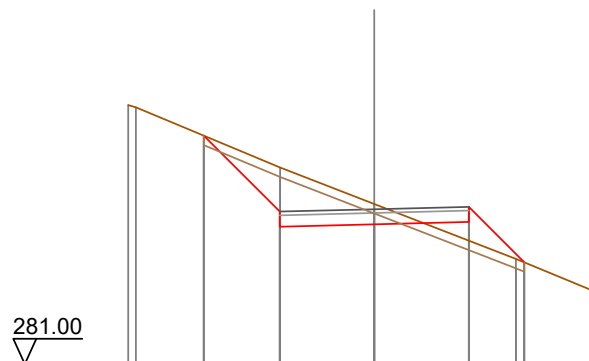

Quote Terreno	-287.85	-287.79		-286.20	-285.24		-283.78	-282.86
Quote Progetto		287.04	284.63	284.70	284.76	283.69		
Parziali			2.01	2.50	2.50	1.47		
Progressiva		-4.51	-2.50	0.00	2.50	3.97		
Dislivelli		0.00	-1.17	-0.54	0.49	0.00		

Sezione: 111
 Progressiva: 550.000
 Q. Progetto: 285.382

282.00

Quote Terreno	-288.66	-288.01	-284.92	-285.94	-284.84	-283.71	-283.66
Quote Progetto		288.08	284.92	284.98	285.04	284.52	
Parziali		2.76	2.50	2.50	0.93		
Progressiva		-5.26	-2.50	0.00	2.50	3.43	
Dislivelli		0.00	-1.65	-0.96	0.13	0.00	

Sezione: 112
 Progressiva: 551.801
 Q. Progetto: 285.447

282.00

Quote Terreno	-288.79	-287.99	-284.98	-286.13	-285.46	-283.92
Quote Progetto		288.21	284.98	285.05	285.11	284.77
Parziali		2.82	2.50	2.50	0.73	
Progressiva		-5.32	-2.50	0.00	2.50	3.23
Dislivelli		0.00	-1.76	-1.08	0.02	0.00

Sezione: 113
 Progressiva: 553.759
 Q. Progetto: 285.517

283.00

Quote Terreno	-288.96	-287.96	-286.34	-286.10	-284.21	
Quote Progetto		288.38	285.05	285.12	285.18	285.06
Parziali		2.93	2.50	2.50	0.52	
Progressiva		-5.43	-2.50	0.00	2.50	3.02
Dislivelli		0.00	-1.90	-1.22	-0.10	0.00

Sezione: 114
 Progressiva: 560.000
 Q. Progetto: 285.742

283.00

Quote Terreno	-289.81	-288.35	-287.97	-287.80	-286.99	-284.93
Quote Progetto		289.20	285.28	285.34	285.40	285.84
Parziali		3.52	2.50	2.50		
Progressiva		-6.02	-2.50	0.00	2.50	2.54
Dislivelli		0.00	-2.39	-1.65	-0.45	-0.00

Sezione: 115
 Progressiva: 566.659
 Q. Progetto: 285.981

284.00

Quote Terreno	-290.51	-288.96	-287.43	-286.79	-286.19	-285.52
Quote Progetto		289.77	285.52	285.56	285.64	286.33
Parziali		3.85	2.50	2.50	0.78	
Progressiva		-6.35	-2.50	0.00	2.50	2.78
Dislivelli		-0.00	-2.42	-1.84	-0.81	0.00

Sezione: 116
 Progressiva: 570.000
 Q. Progetto: 286.101

284.00

Quote Terreno	-290.73	-290.68	-289.43	-287.69	-286.64	-285.86	-285.53
Quote Progetto		290.06	285.64	285.70	286.45	286.45	286.45
Parziali		4.02	2.50	2.50	0.78		
Progressiva		-6.52	-2.50	0.00	2.50	2.79	
Dislivelli		0.00	-2.56	-1.99	-0.82	0.00	

Sezione: 117
 Progressiva: 579.559
 Q. Progetto: 286.445

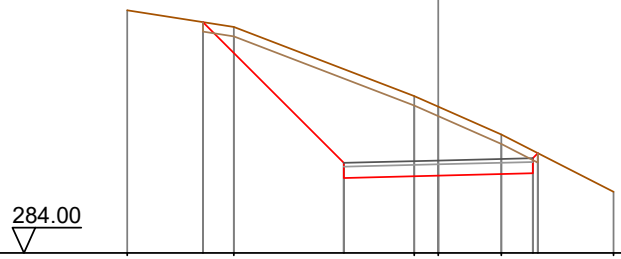

Quote Terreno	-290.42	-289.98	-288.15	-287.13	-285.62
Quote Progetto		290.11	285.98	286.05	286.11
Parziali		3.72	2.50	2.50	
Progressiva		-6.22	-2.50	0.00	2.50
Dislivelli		0.00	-2.48	-1.82	-0.60

Sezione: 118
 Progressiva: 580.000
 Q. Progetto: 286.461

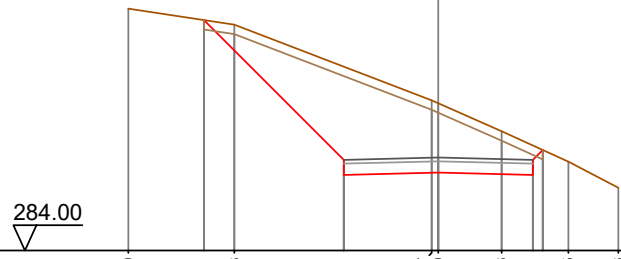

Quote Terreno	-290.40	-289.98	-287.97	-287.16	-286.35
Quote Progetto		290.10	286.00	286.06	286.00
Parziali		3.70	2.50	2.50	0.78
Progressiva		-6.20	-2.50	0.00	2.50
Dislivelli		0.00	-2.47	-1.83	-0.78

Sezione: 119
 Progressiva: 587.116
 Q. Progetto: 286.717

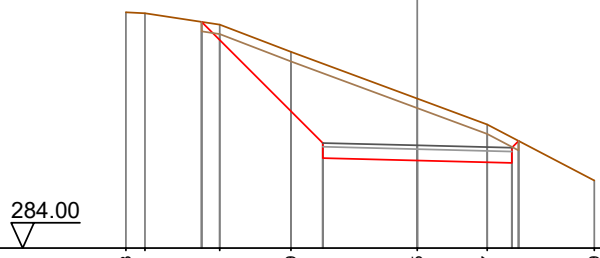

Quote Terreno	-290.23	-290.21	-289.91	-289.19	-287.95	-287.27	-285.79
Quote Progetto			289.98	286.38	286.32	286.25	286.83
Parziali			3.20	2.50	2.50		
Progressiva			-5.70	-2.50	0.00	2.50	2.68
Dislivelli			-0.00	-2.10	-1.64	-0.67	0.00

Sezione: 120
 Progressiva: 590.000
 Q. Progetto: 286.820

284.00

Quote Terreno	-289.97	-289.93	-289.90	-289.45	-287.96	-287.28	-285.83
Quote Progetto			289.91	286.48	286.42	286.36	286.87
Parziali			3.03	2.50	2.50		
Progressiva			-5.53	-2.50	0.00	2.50	2.62
Dislivelli			0.00	-2.00	-1.54	-0.58	0.00

Sezione: 121
 Progressiva: 593.083
 Q. Progetto: 286.931

284.00

Quote Terreno	-289.97	-289.93	-288.33	-287.90	-287.30	-285.78
Quote Progetto		289.92	286.59	286.53	286.47	286.63
Parziali		2.92	2.50	2.50		
Progressiva		-5.42	-2.50	0.00	2.50	2.54
Dislivelli		0.00	-1.83	-1.37	-0.38	-0.00

Sezione: 122
 Progressiva: 599.049
 Q. Progetto: 287.146

284.00

Quote Terreno	289.98	289.98	288.68	287.73	287.50	286.35	285.28
Quote Progetto			289.27	286.81	286.75	286.68	286.23
Parziali			2.06	2.50	2.50	0.85	
Progressiva			-4.56	-2.50	0.00	2.50	3.35
Dislivelli			0.00	-1.33	-0.99	0.04	0.00

Sezione: 123
 Progressiva: 600.000
 Q. Progetto: 287.180

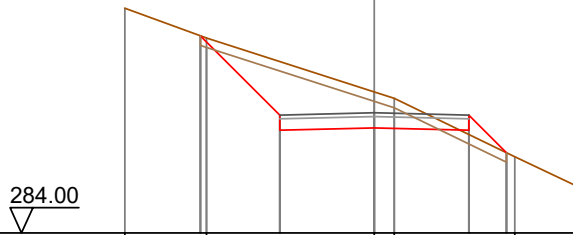

Quote Terreno	-289.95	-289.16		-287.73	-287.56	-286.02	-285.17
Quote Progetto		289.21	286.72	286.78	286.72	286.12	
Parziali			2.10	2.50	2.50	0.99	
Progressiva		-4.60	-2.50	0.00	2.50	3.49	
Dislivelli		0.00	-1.42	-0.95	0.11	-0.00	

Sezione: 124
 Progressiva: 617.451
 Q. Progetto: 287.930

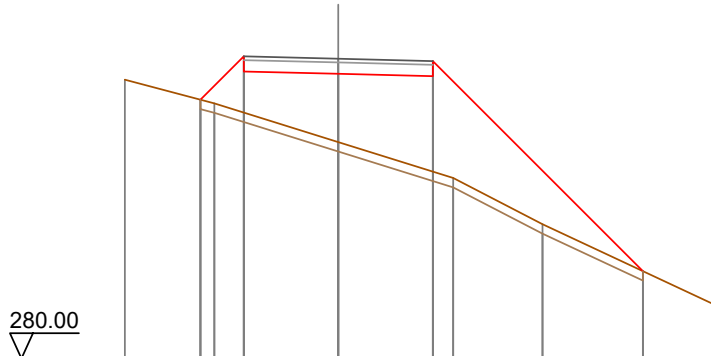

Quote Terreno	-287.38	-286.75		-285.73	-284.78	-283.55	-281.38
Quote Progetto		286.85	287.59	287.53	287.47		282.31
Parziali			1.15	2.50	2.50	5.56	
Progressiva		-3.65	-2.50	0.00	2.50		8.06
Dislivelli		0.00	1.49	1.81	2.52		0.00

Sezione: 125
 Progressiva: 620.000
 Q. Progetto: 288.085

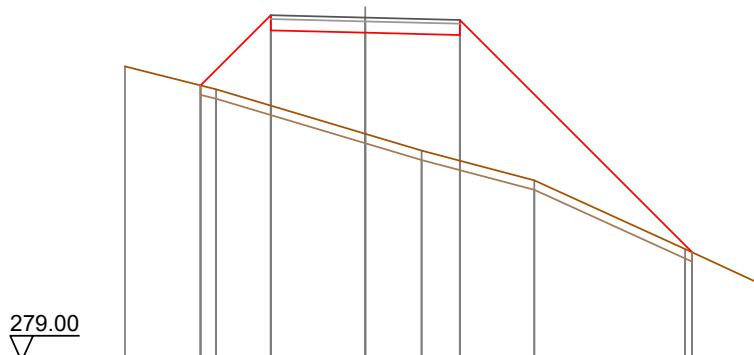

Quote Terreno	-286.79	-286.19		-285.01	-284.57	-283.78	-281.97	-280.95
Quote Progetto		286.29	287.75	287.69	287.62		281.88	
Parziali			1.86	2.50	2.50		6.14	
Progressiva		-4.36	-2.50	0.00	2.50		8.64	
Dislivelli		0.00	2.39	2.67	3.32		0.00	

Sezione: 126
 Progressiva: 623.230
 Q. Progetto: 288.300

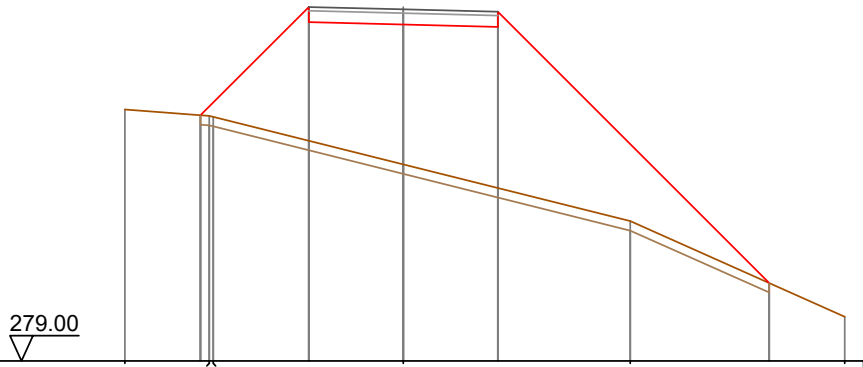

Quote Terreno	-285.65	285.48 285.46		284.20		282.70	-280.17
Quote Progetto		285.50	287.96	287.90	287.84		281.06
Parziali		2.86	2.50	2.50		7.18	
Progressiva		-5.36	-2.50	0.00	2.50		9.68
Dislivelli		0.00	3.54	3.70	4.26		0.00

Sezione: 127
 Progressiva: 629.008
 Q. Progetto: 288.737

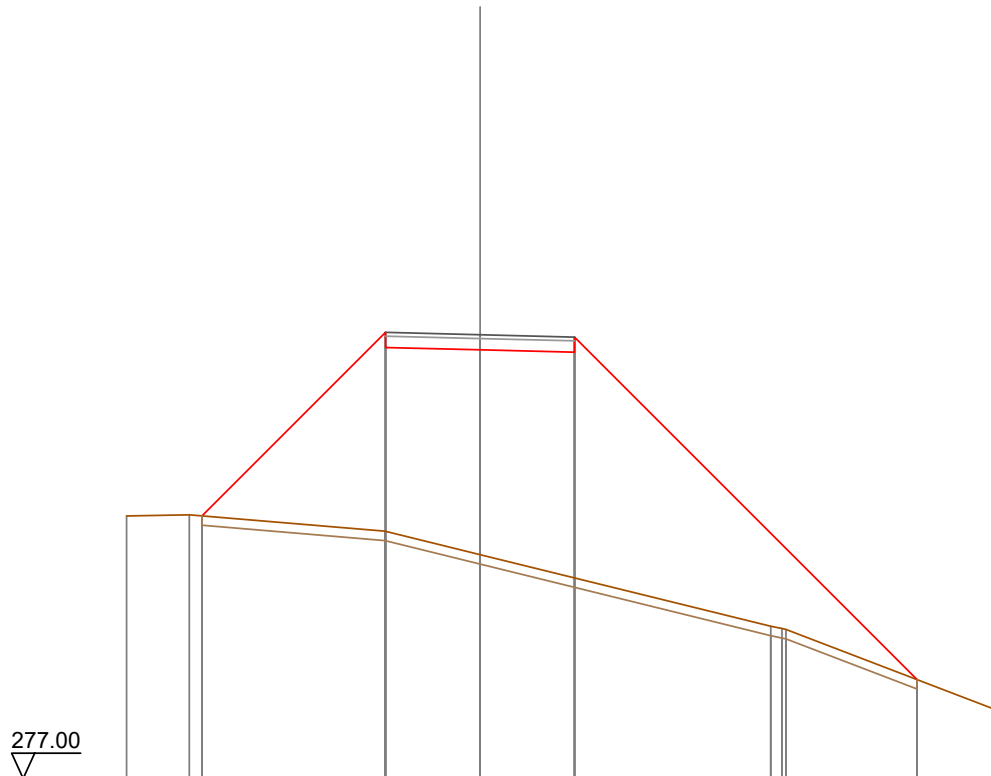

Quote Terreno		283.95	283.98	283.54	282.92	288.27	281.03	280.94	279.62	278.65
Quote Progetto			283.95	288.40	288.34	288.27			279.62	
Parziali				4.85	2.50	2.50		9.06		
Progressiva			-7.35	-2.50	0.00	2.50			11.56	
Dislivelli			0.00	5.26	5.42	5.97			0.00	

Sezione: 129
 Progressiva: 653.537
 Q. Progetto: 291.346

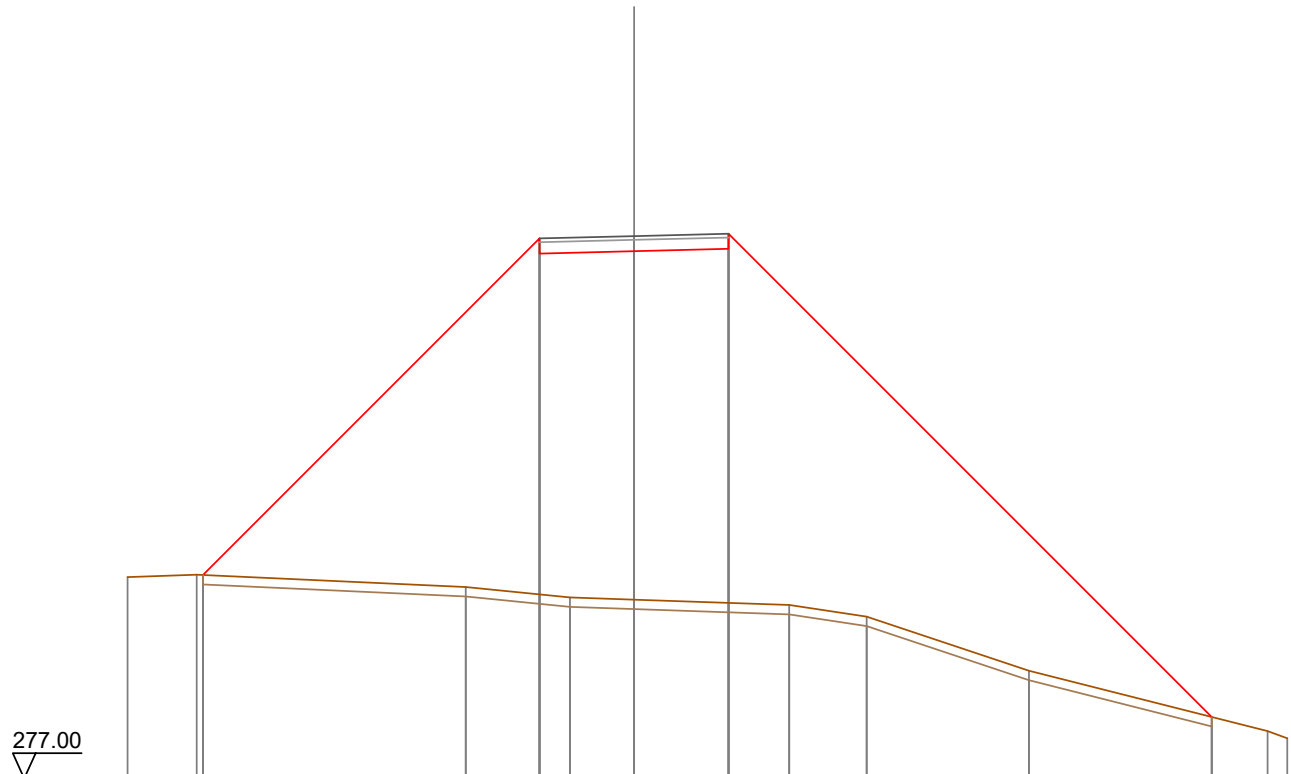

Quote Terreno	282.33	282.39	282.07	281.79	281.73	281.59	281.28	279.85	278.26	278.06
Quote Progetto		282.38		290.88	290.95	291.01			278.63	
Parziali			8.90	2.50	2.50			12.78		
Progressiva		-11.40		-2.50	0.00	2.50			15.28	
Dislivelli		0.00		9.41	9.21	9.36			-0.00	

Sezione: 130
 Progressiva: 654.438
 Q. Progetto: 291.465

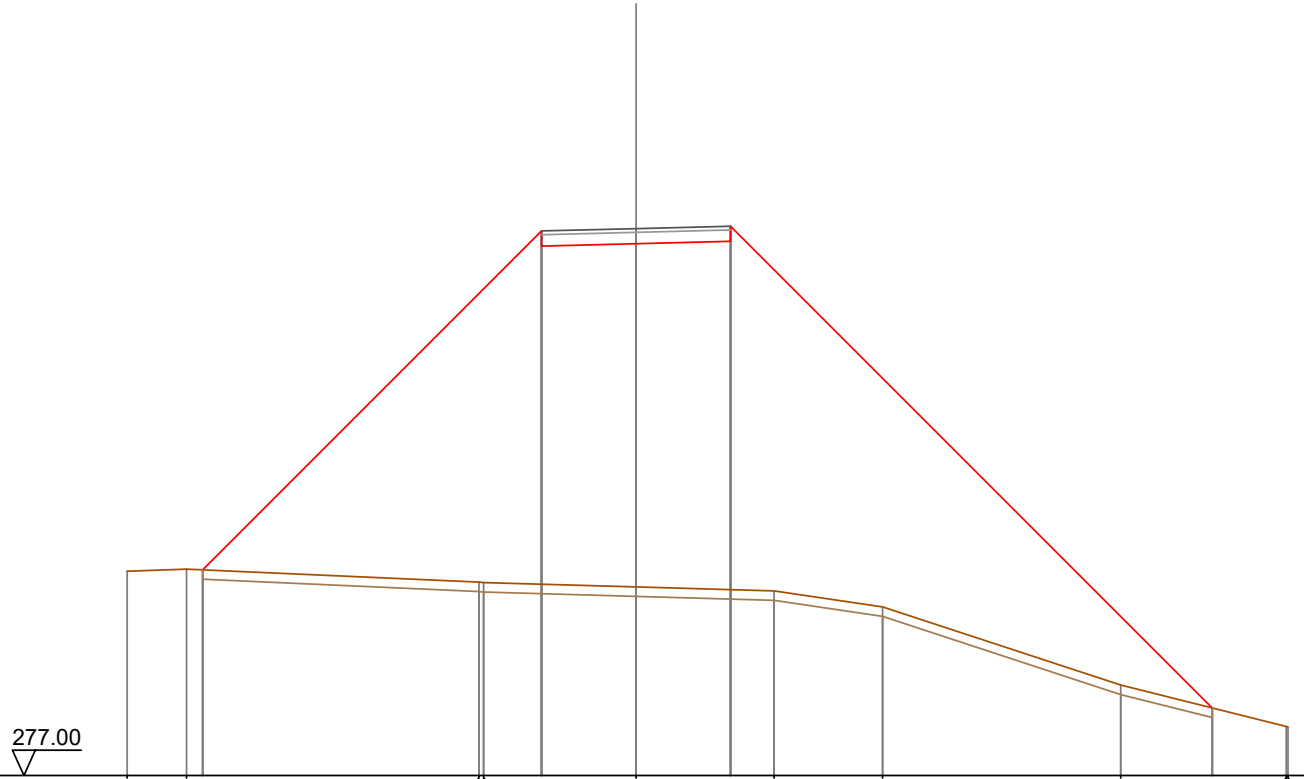

Quote Terreno	-282.40	-282.46	-282.12	-282.10	-281.99	-281.88	-281.46	-279.39	-278.30	-278.28
Quote Progetto		282.44			291.00	291.06	291.13		278.79	
Parziali			8.96		2.50	2.50		12.74		
Progressiva		-11.46			-2.50	0.00	2.50		15.24	
Dislivelli		0.00			9.34	9.08	9.21		0.00	

Sezione: 131
 Progressiva: 655.338
 Q. Progetto: 291.586

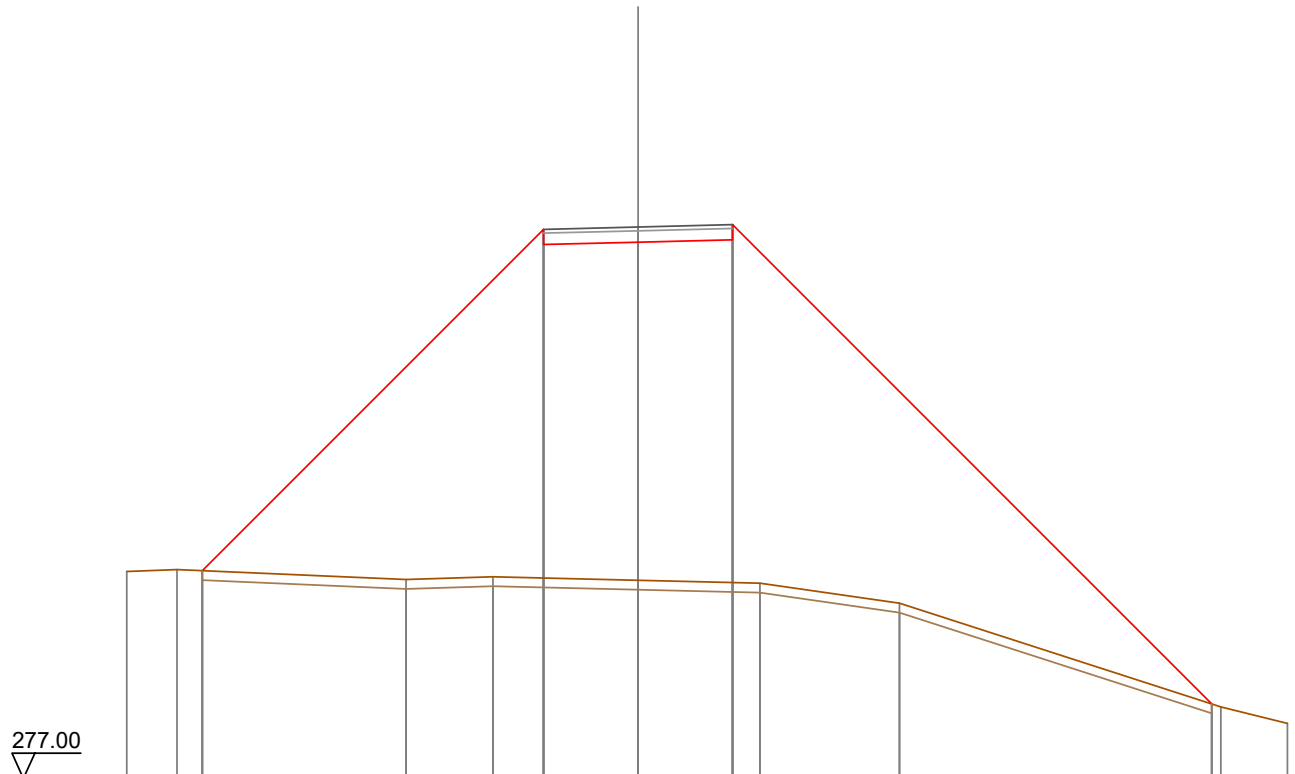

Quote Terreno	-282.47	-282.53	-282.27	-282.34	-282.24	-282.17	-281.64	-278.90	-278.46
Quote Progetto		-282.50		-291.12	-291.19	-291.25		-278.97	
Parziali			9.03		2.50	2.50		12.67	
Progressiva		-11.53		-2.50	0.00	2.50		15.17	
Dislivelli		0.00		9.22	8.84	9.06		0.00	

Sezione: 132
 Progressiva: 660.000
 Q. Progetto: 292.238

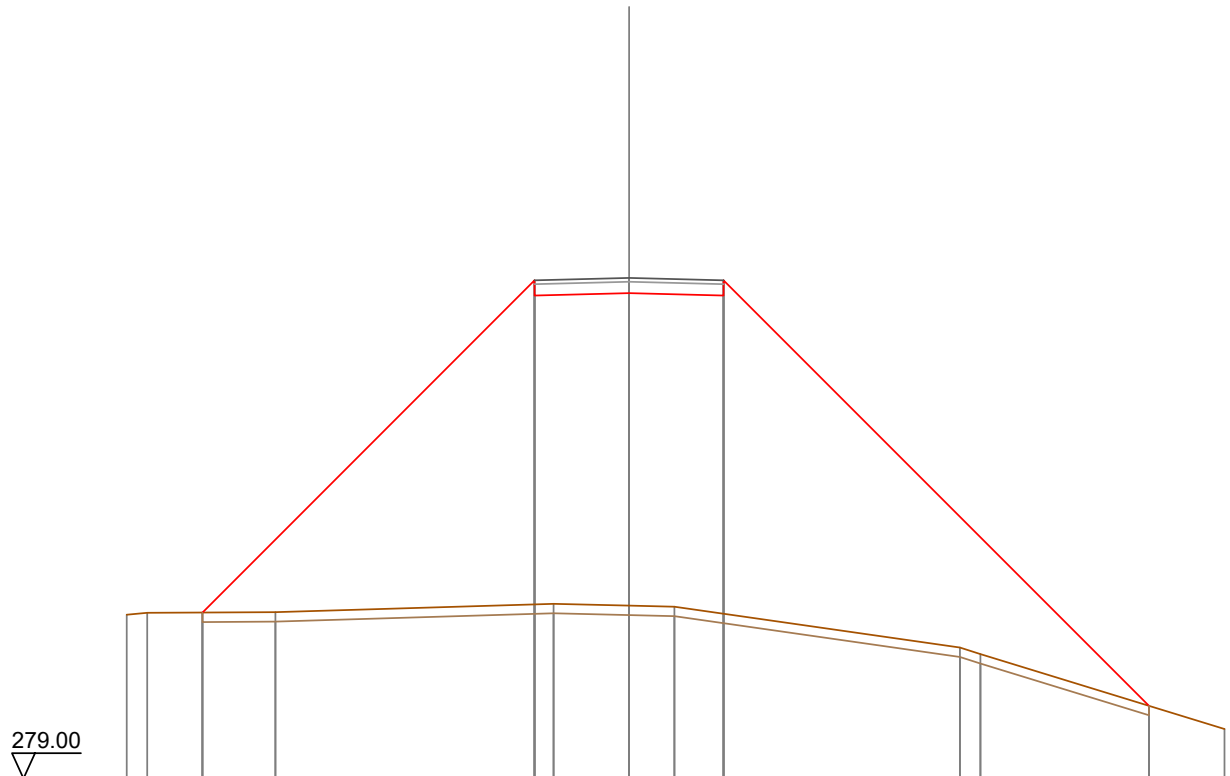

Quote Terreno		283.33	283.38		283.40		283.62	283.57	283.55		282.47	282.29		280.31
Quote Progetto				283.39			291.78	291.84	291.78				280.92	
Parziali					8.79		2.50	2.50			11.25			
Progressiva				-11.29			-2.50	0.00	2.50				13.75	
Dislivelli				-0.00			8.57	8.26	8.42				-0.00	

Sezione: 133
 Progressiva: 680.000
 Q. Progetto: 295.514

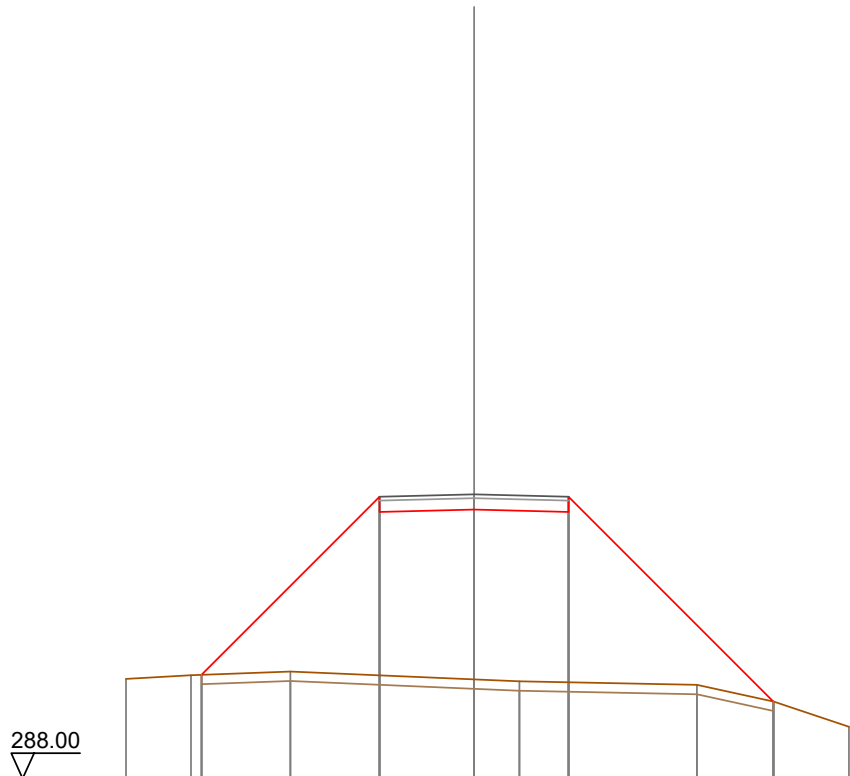

Quote Terreno		290.64	290.73	290.83	290.62	290.57	290.48	290.03	289.37
Quote Progetto			290.74		295.05	295.11	295.05	290.04	
Parziali				4.71	2.50	2.50	5.41		
Progressiva			-7.21		-2.50	0.00	2.50	7.91	
Dislivelli			0.00		4.72	4.49	4.51	0.00	

Sezione: 134
 Progressiva: 690.424
 Q. Progetto: 297.336

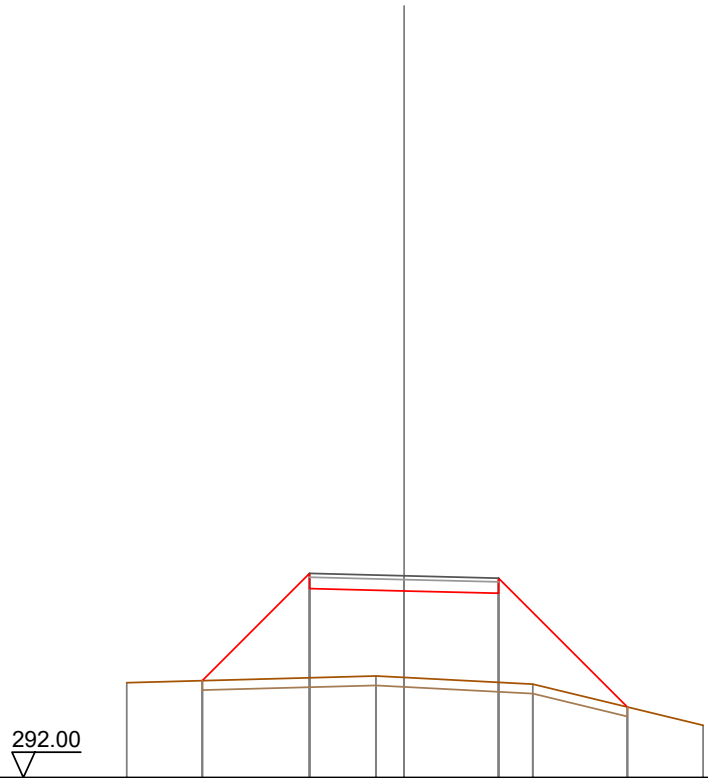

Quote Terreno		-294.51		-294.69	-294.65	-294.47		-293.38
Quote Progetto			294.56	297.00	296.94	296.87		293.87
Parziali			2.84	2.50	2.50	3.41		
Progressiva			-5.34	-2.50	0.00	2.50		5.91
Dislivelli			0.00	2.76	2.29	2.36		0.00

Sezione: 135
 Progressiva: 691.194
 Q. Progetto: 297.469

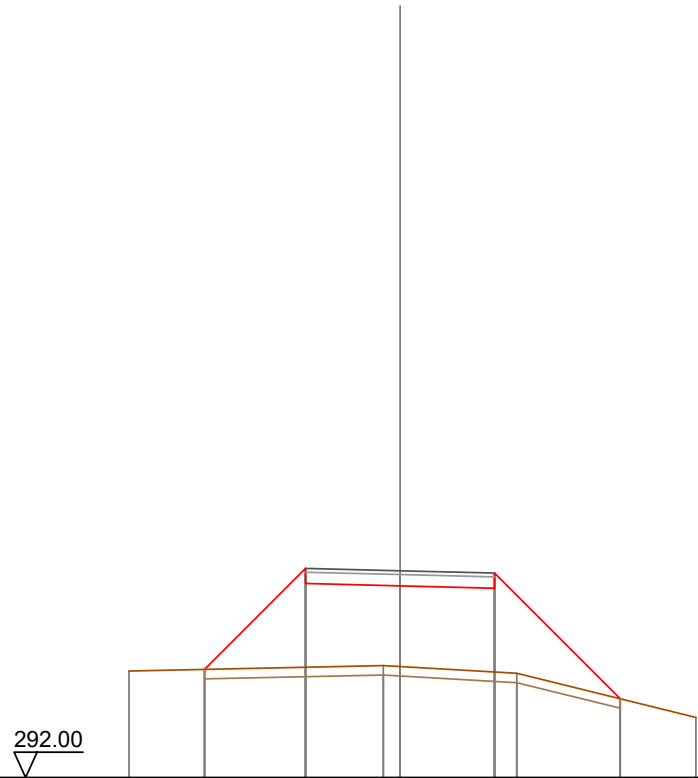

Quote Terreno		-294.82			-294.86	-294.93	-294.96	-294.76		-293.59
Quote Progetto			294.86	297.13	297.07	297.01		294.08		
Parziali				2.67	2.50	2.50	3.32			
Progressiva			-5.17	-2.50	0.00	2.50	5.82			
Dislivelli			-0.00	2.61	2.13	2.21	-0.00			

Sezione: 136
 Progressiva: 691.963
 Q. Progetto: 297.600

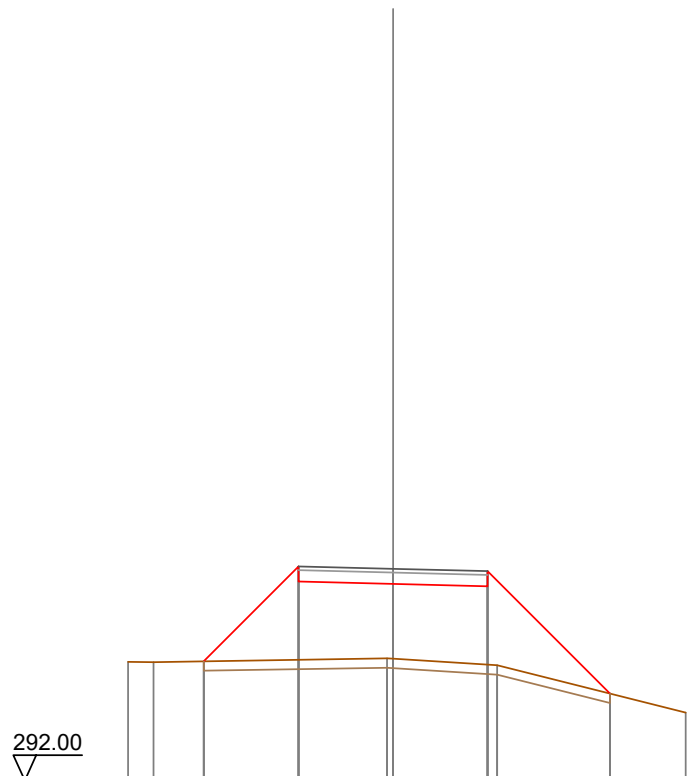

Quote Terreno		295.14	295.13		295.23	295.22	295.05		293.80
Quote Progetto			295.15	297.26	297.20	297.14	294.30		
Parziali			2.51	2.50	2.50	3.24			
Progressiva			-5.01	-2.50	0.00	2.50	5.74		
Dislivelli			0.00	2.47	1.98	2.07	-0.00		

Sezione: 137
 Progressiva: 700.000
 Q. Progetto: 298.903

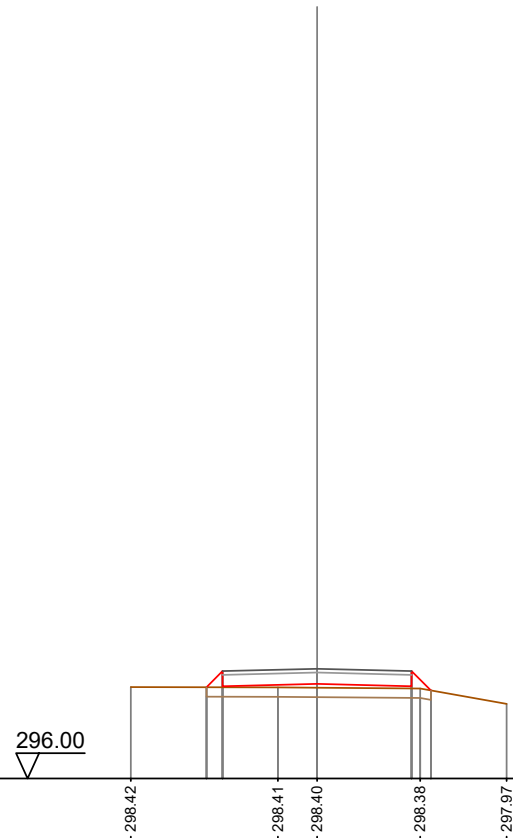

Quote Terreno		-298.42		-298.41	-298.40		-298.38		-297.97
Quote Progetto			298.42	298.44		298.50		298.44	298.33
Parziali			0.43	2.50		2.50		0.51	
Progressiva			-2.93	-2.50		0.00		2.50	3.01
Dislivelli			0.00	0.43		0.10		0.06	0.00

Sezione: 138
 Progressiva: 703.514
 Q. Progetto: 299.431

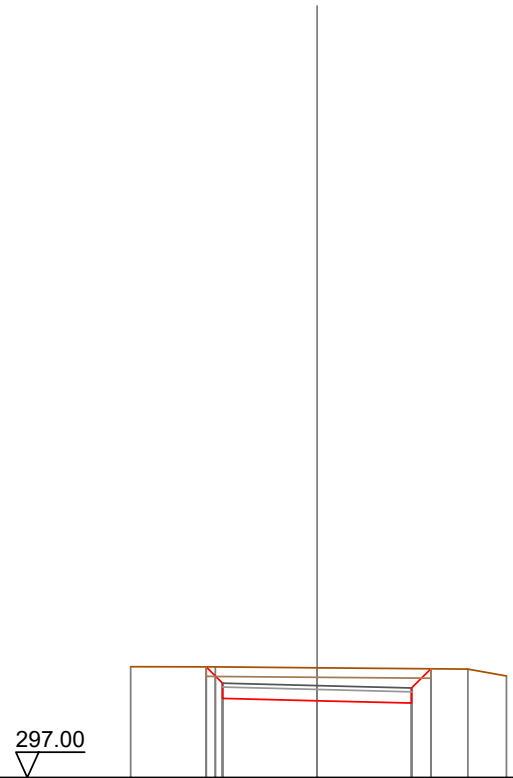

Quote Terreno		299.93	299.93	299.90	299.87	299.69
Quote Progetto		299.93	299.09	299.03	298.87	299.88
Parziali		0.43	2.50	2.50	0.51	
Progressiva		-2.93	-2.50	0.00	2.50	3.01
Dislivelli		0.00	-0.43	-0.87	-0.91	0.00

Sezione: 139
 Progressiva: 710.000
 Q. Progetto: 300.338

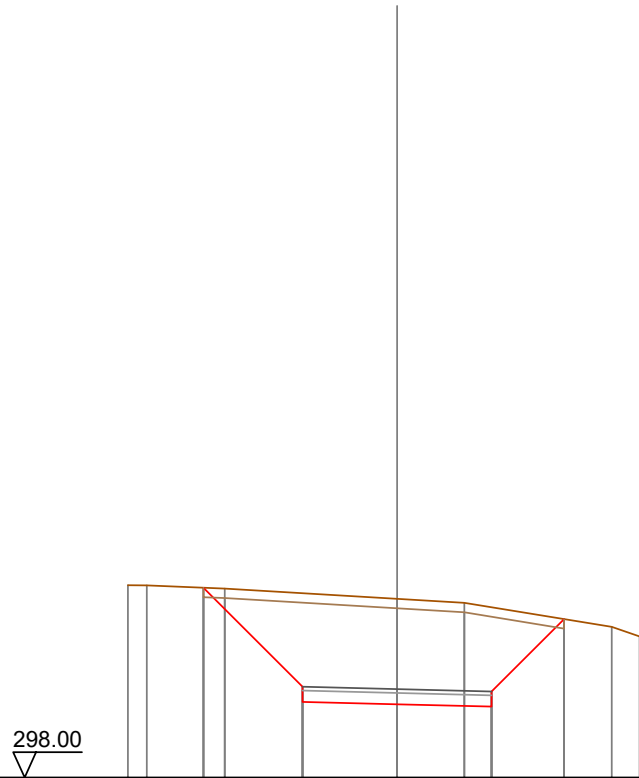

Quote Terreno		-303.08	-303.08	-303.00		302.73	-302.62		-301.98	-301.73
Quote Progetto			303.02	300.00		299.94	299.88		302.19	
Parziali				2.62	2.50		2.50	1.91		
Progressiva			-5.12	-2.50		0.00	2.50	4.41		
Dislivelli			0.00	-2.47		-2.79	-2.63	0.00		

Sezione: 140
 Progressiva: 716.306
 Q. Progetto: 301.137

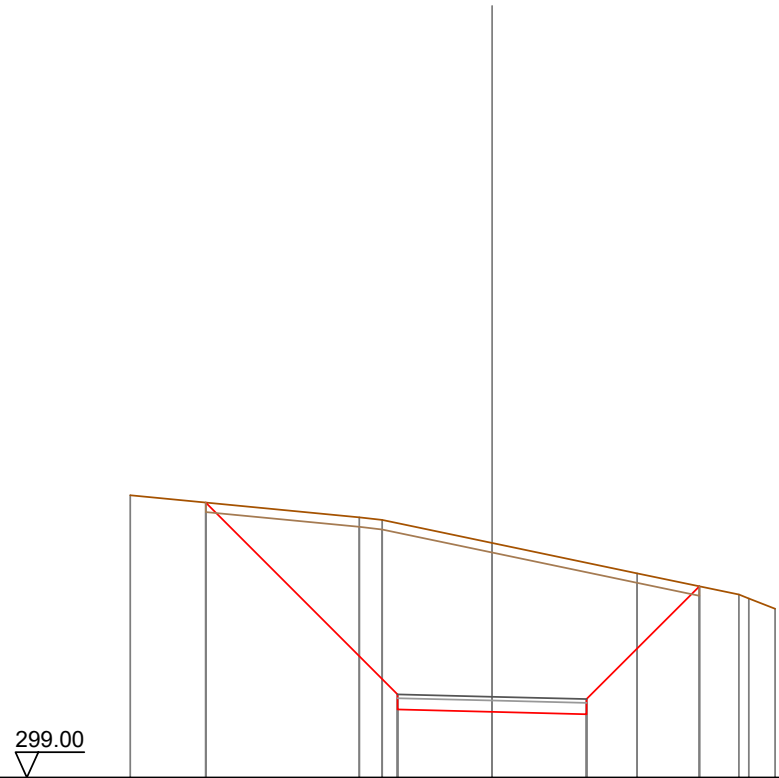

Quote Terreno		-306.46		-305.88	-305.81	-305.20		-304.40	-303.84	-303.73	-303.46
Quote Progetto			306.27		300.80	300.74		300.67		304.06	
Parziali				5.07		2.50	2.50		2.98		
Progressiva			-7.57		-2.50	0.00		2.50		5.48	
Dislivelli			-0.00		-4.53	-4.47		-4.00		-0.00	

Sezione: 141
 Progressiva: 720.000
 Q. Progetto: 301.567

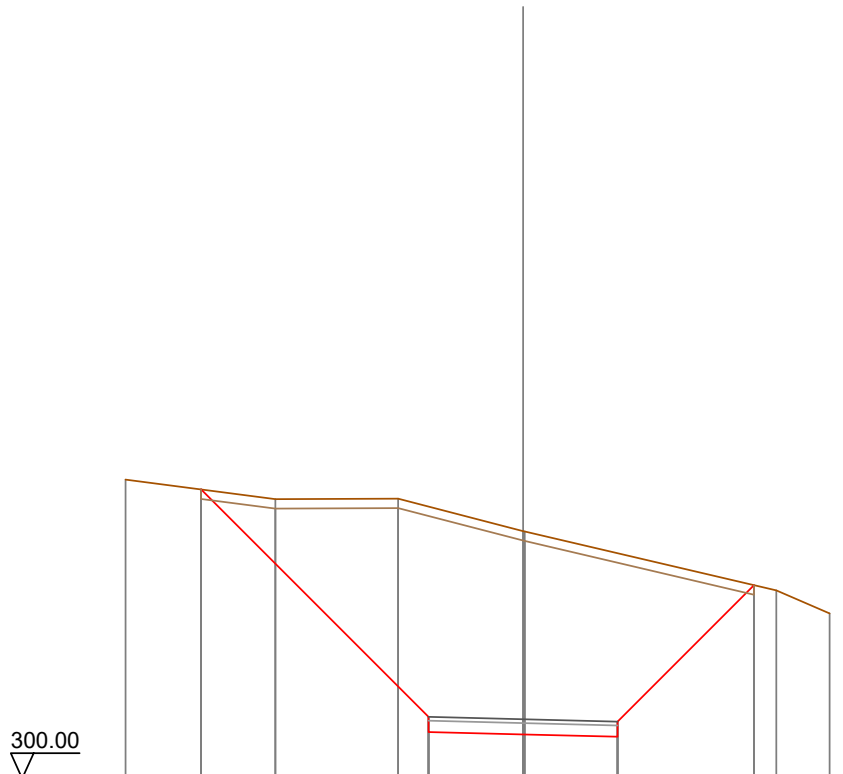

300.00

Quote Terreno	-307.91	-307.39	-307.40	306.54 306.53	-304.97	-304.37
Quote Progetto	307.65	301.23	301.17	301.10	305.11	
Parziali		6.02	2.50	2.50	3.61	
Progressiva	-8.52	-2.50	0.00	2.50	6.11	
Dislivelli	-0.00	-5.56	-5.38	-4.85	0.00	

Sezione: 142
 Progressiva: 729.098
 Q. Progetto: 302.509

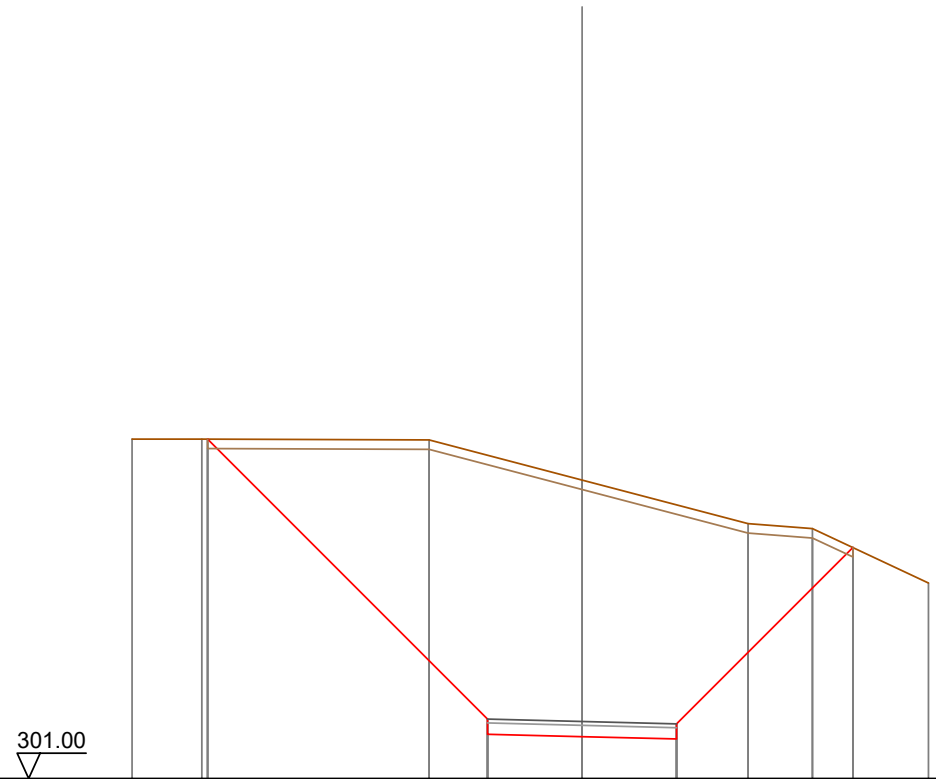

Quote Terreno	-309.98	309.98	-309.96	308.89	-307.74	-307.61	-306.17
Quote Progetto		309.98	302.17	302.11	302.05	307.11	
Parziali		7.40	2.50	2.50	4.66		
Progressiva		-9.90	-2.50	0.00	2.50	7.16	
Dislivelli		0.00	-6.98	-6.79	-6.19	0.00	

Sezione: 143
 Progressiva: 730.285
 Q. Progetto: 302.619

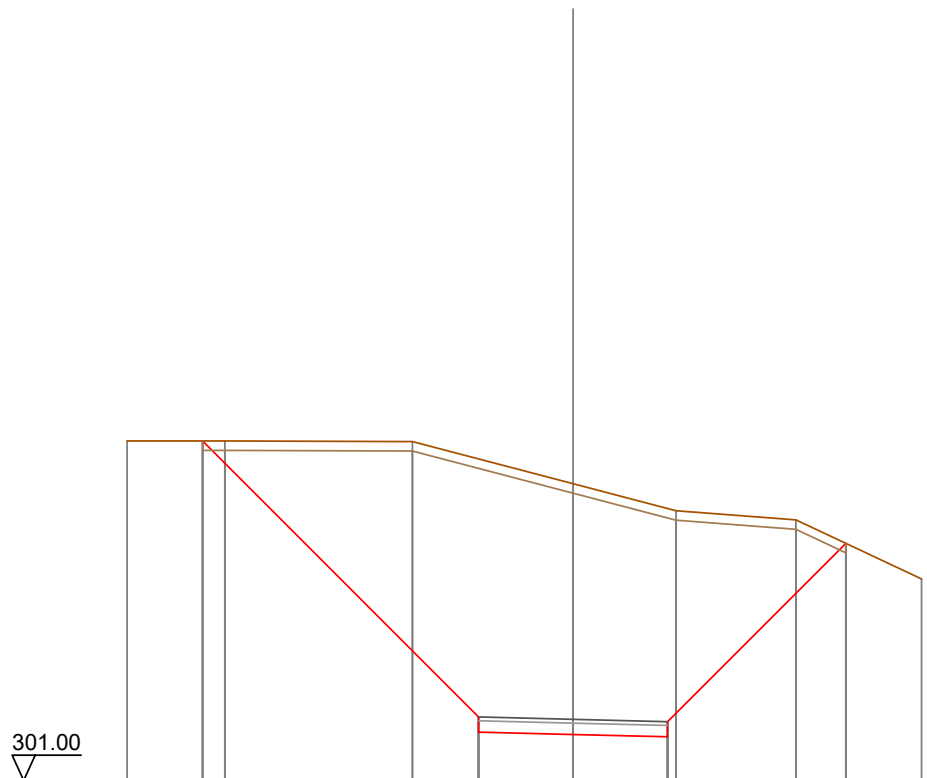

Quote Terreno		-309.98	-309.98	-309.96		308.85	308.13	-307.89		-306.33
Quote Progetto			309.98		302.28	302.22	302.16		307.27	
Parziali				7.30		2.50	2.50		4.72	
Progressiva			-9.80		-2.50	0.00	2.50		7.22	
Dislivelli			0.00		-6.82	-6.63	-6.04		0.00	

Sezione: 144
 Progressiva: 740.000
 Q. Progetto: 303.415

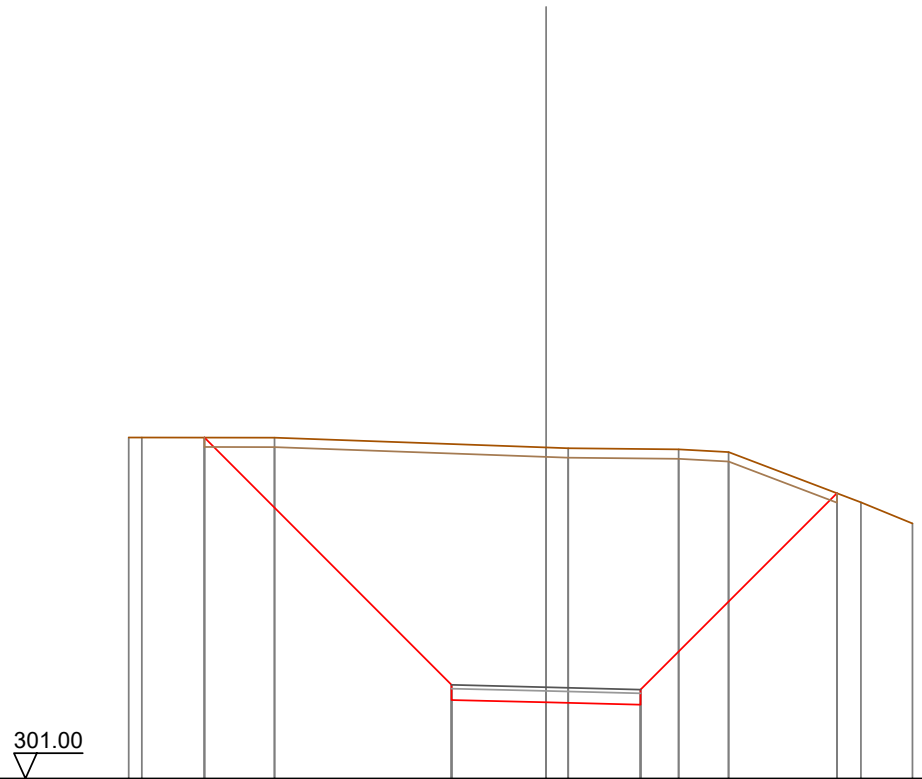

Quote Terreno		310.02	310.02		310.02		309.75	309.73		309.71	309.63		308.30	307.75
Quote Progetto			310.02		303.08		303.02	309.73		302.95			308.54	
Parziali				6.54		2.50	2.50		5.19					
Progressiva			-9.04		-2.50	0.00	2.50		7.69					
Dislivelli			-0.00		-6.37	-6.74	-6.76		0.00					

Sezione: 145
 Progressiva: 748.406
 Q. Progetto: 303.951

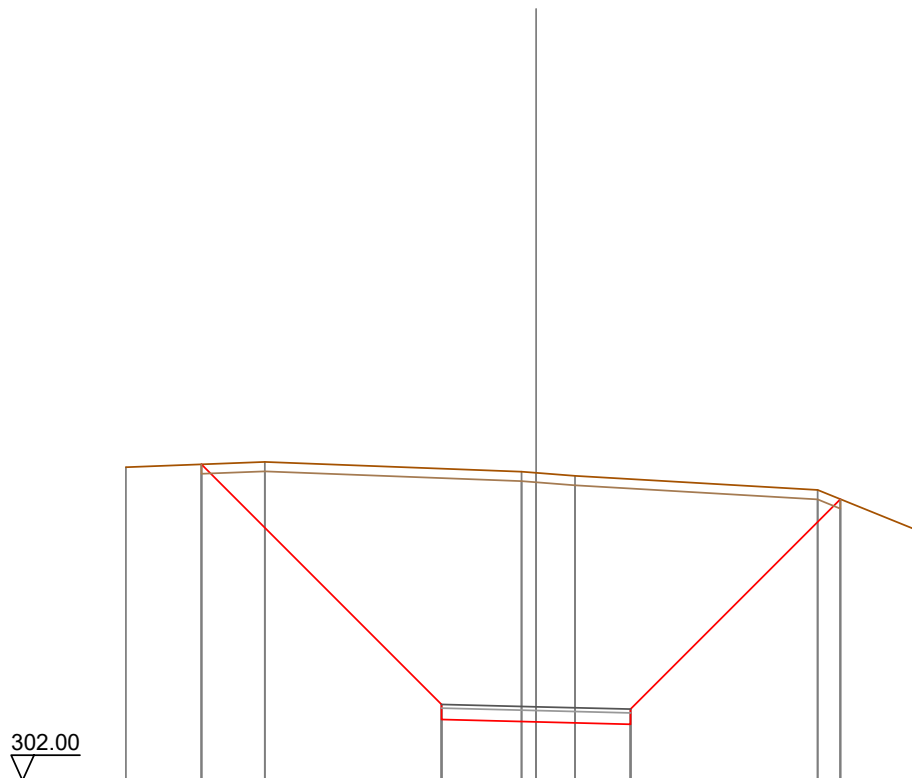

Quote Terreno	310.29	310.43	310.17	310.14	310.06	309.68	308.63
Quote Progetto		310.36	303.61	303.55	303.49	309.44	
Parziali		6.35	2.50	2.50	5.55		
Progressiva		-8.85	-2.50	0.00	2.50	8.05	
Dislivelli		0.00	-6.24	-6.59	-6.48	0.00	

Sezione: 146
 Progressiva: 750.000
 Q. Progetto: 304.037

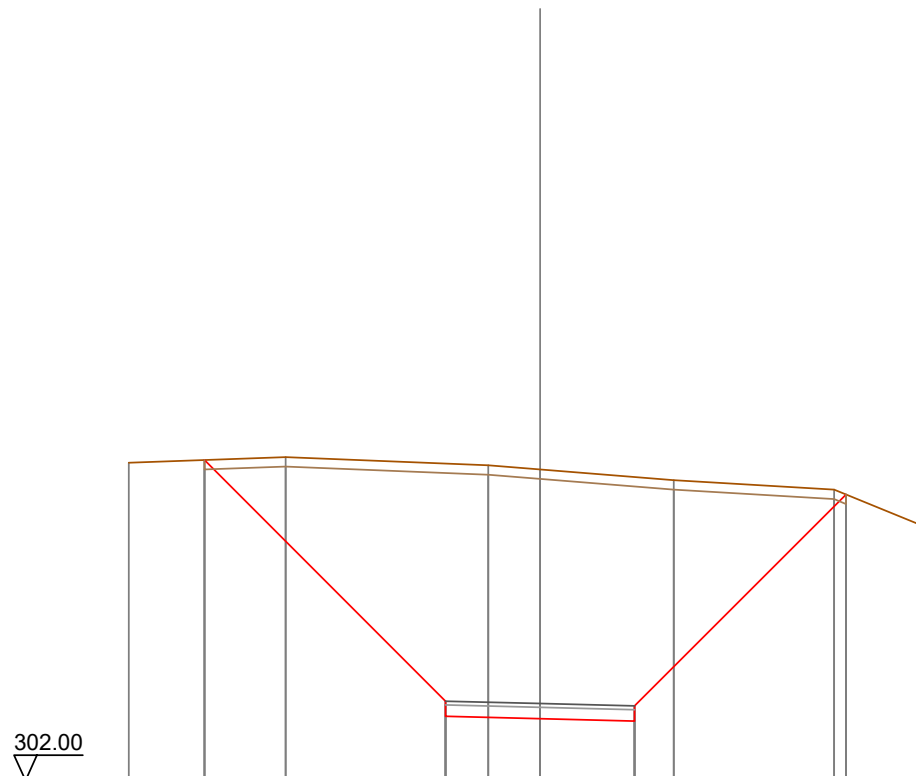

Quote Terreno		310.41		310.55		310.34	310.23		309.94		309.69		308.75
Quote Progetto			310.48			303.70	303.64		303.57		309.56		
Parziali				6.38		2.50	2.50		5.59				
Progressiva			-8.88			-2.50	0.00		2.50		8.09		
Dislivelli			0.00			-6.28	-6.59		-6.45		0.00		

Sezione: 147
 Progressiva: 760.000
 Q. Progetto: 304.457

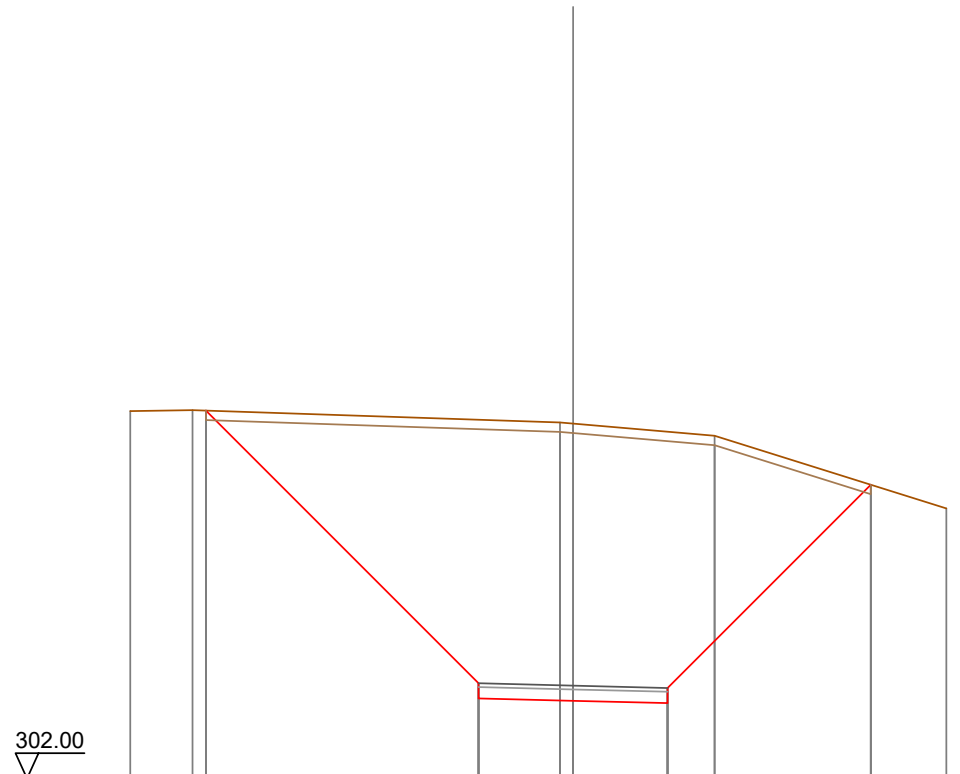

Quote Terreno	-311.72	-311.74	-311.42	-311.39	-311.07	-309.14
Quote Progetto		311.73	304.12	304.06	303.99	309.77
Parziali		7.21	2.50	2.50	5.37	
Progressiva		-9.71	-2.50	0.00	2.50	7.87
Dislivelli		-0.00	-6.97	-7.33	-7.18	-0.00

Sezione: 148
 Progressiva: 766.527
 Q. Progetto: 304.640

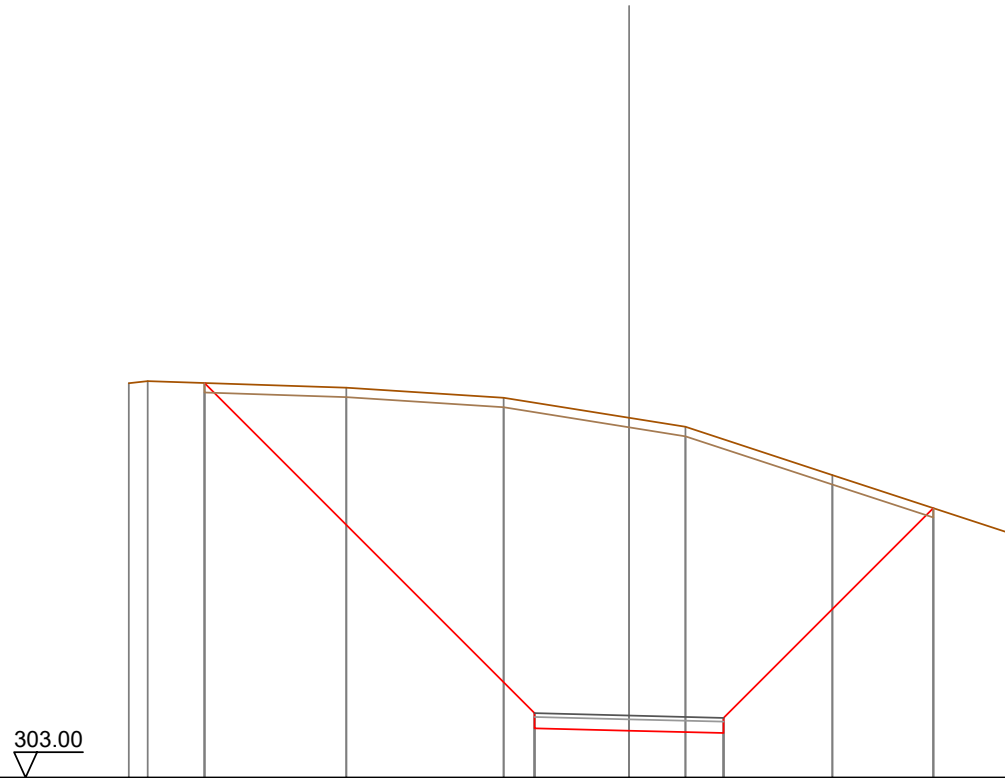

Quote Terreno	313.43	313.48	313.31	313.04	312.51	312.28	311.00	309.47
Quote Progetto		313.43		304.30	304.24	304.18		310.12
Parziali			8.73		2.50	2.50	5.55	
Progressiva		-11.23		-2.50	0.00	2.50		8.05
Dislivelli		0.00		-8.21	-8.27	-7.77		-0.00

Sezione: 149
 Progressiva: 768.836
 Q. Progetto: 304.702

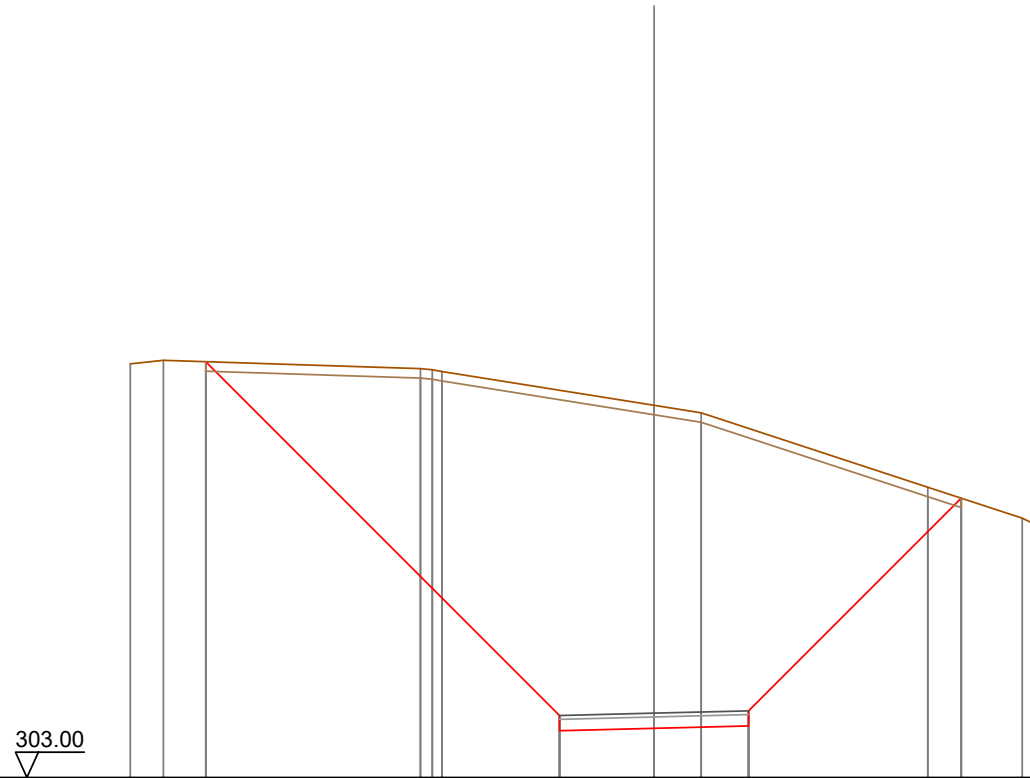

Quote Terreno		313.94	314.03		313.81	313.74		312.84	312.64		310.68	308.86	308.67
Quote Progetto			314.00				304.24	304.30	304.36		310.39		
Parziali				9.36		2.50	2.50		5.62				
Progressiva			-11.86			-2.50	0.00	2.50		8.12			
Dislivelli			0.00			-8.60	-8.54	-7.87		0.00			

Sezione: 150
 Progressiva: 770.000
 Q. Progetto: 304.734

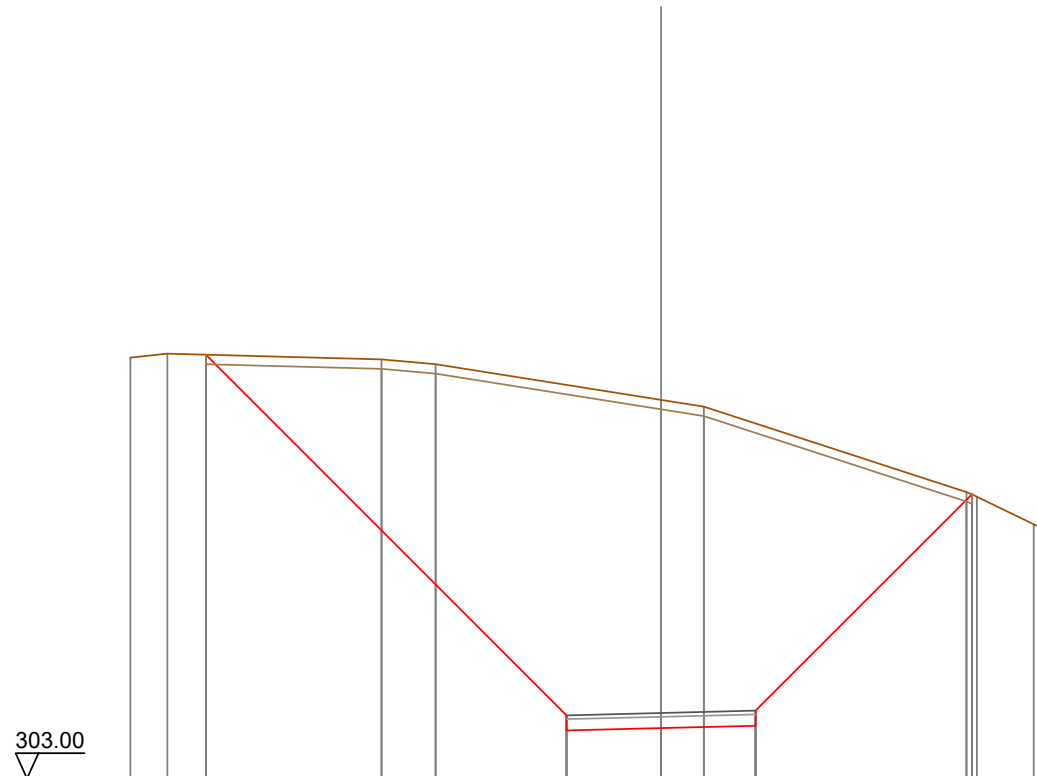

Quote Terreno		-314.13	-314.24		-314.08	-313.96		304.27	304.33	313.01	-312.83		310.58	310.45	-309.72	-309.55
Quote Progetto			314.21					304.27	304.33		304.40		310.52			
Parziali				9.54				2.50	2.50		5.72					
Progressiva			-12.04					-2.50	0.00		2.50		8.22			
Dislivelli			0.00					-8.74	-8.68		-7.99		-0.00			

Sezione: 151
 Progressiva: 775.618
 Q. Progetto: 304.886

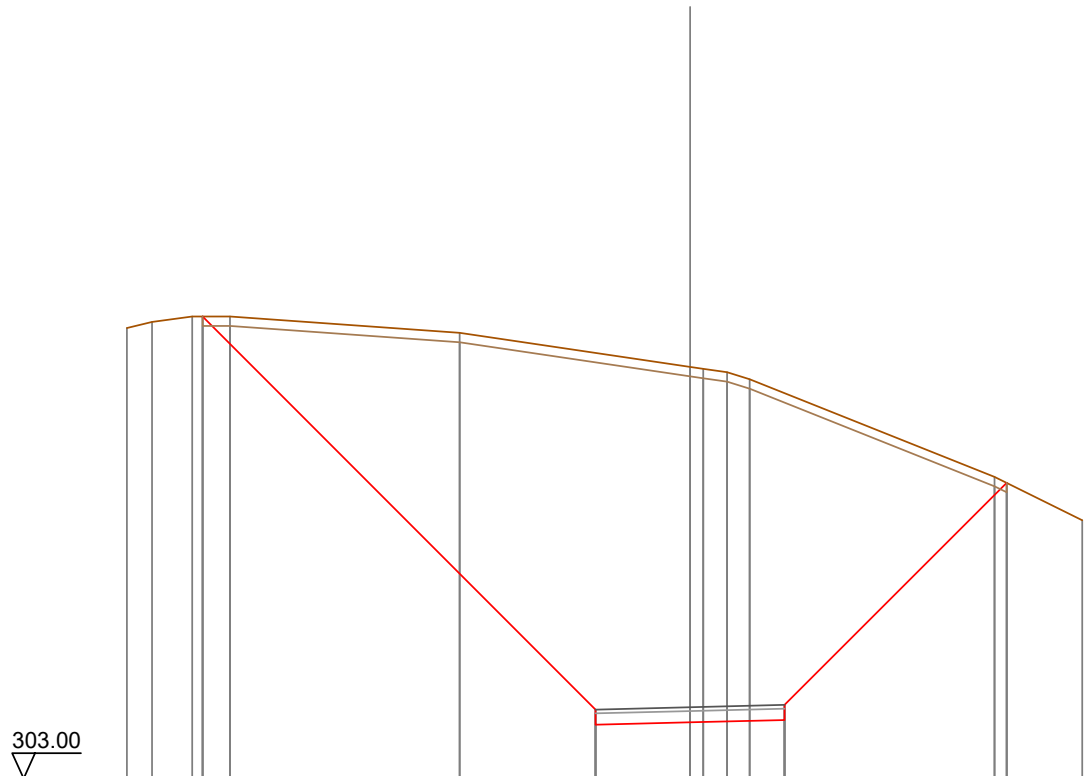

Quote Terreno	-314.92	-315.07	-315.22	-315.22	-314.79	-313.88	-313.83	-313.75	-313.56	-310.98	-309.83
Quote Progetto			315.22			304.42	304.49		304.55	310.82	
Parziali				10.40		2.50	2.50		5.87		
Progressiva			-12.90			-2.50	0.00		2.50	8.37	
Dislivelli			0.00			-9.43	-9.40		-8.64	-0.00	

Sezione: 152
 Progressiva: 780.000
 Q. Progetto: 305.005

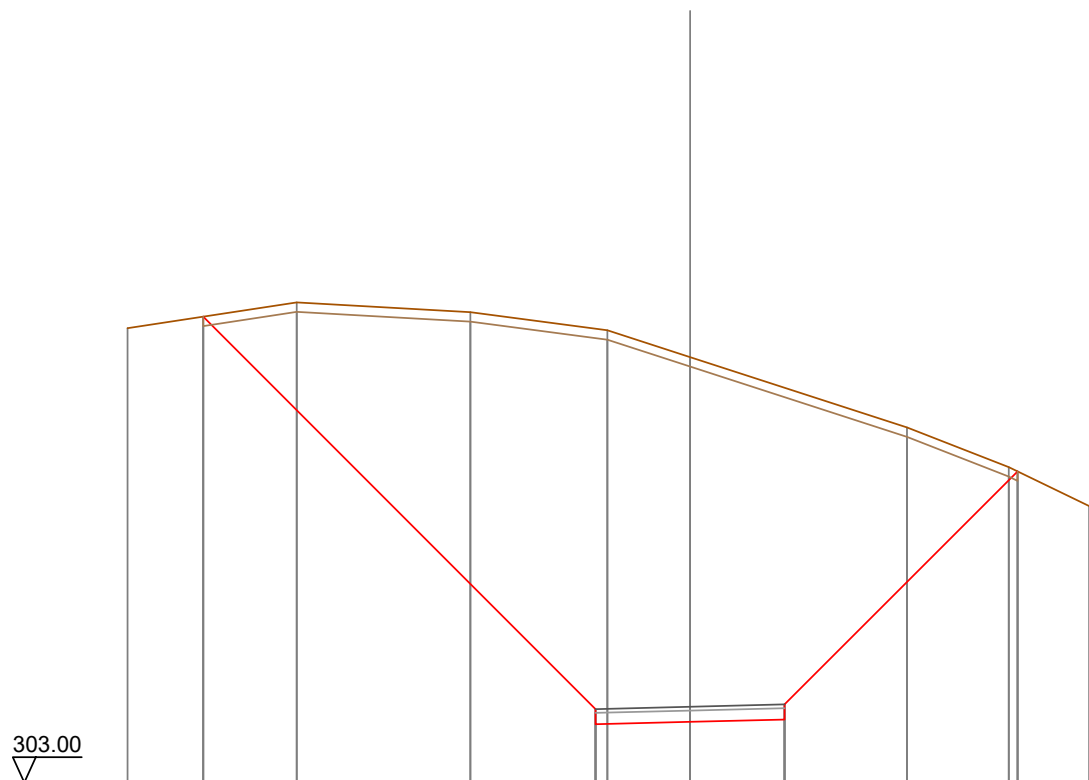

Quote Terreno		-315.02		-315.70		-315.44		-314.96		-314.25		-312.39		-311.34		-310.31		-310.25
Quote Progetto			315.32				304.54		304.60		304.67			311.23				
Parziali				10.38			2.50	2.50		6.16								
Progressiva			-12.88				-2.50	0.00		2.50				8.66				
Dislivelli			0.00				-10.06	-9.65		-8.77				0.00				

Sezione: 153
 Progressiva: 782.401
 Q. Progetto: 305.070

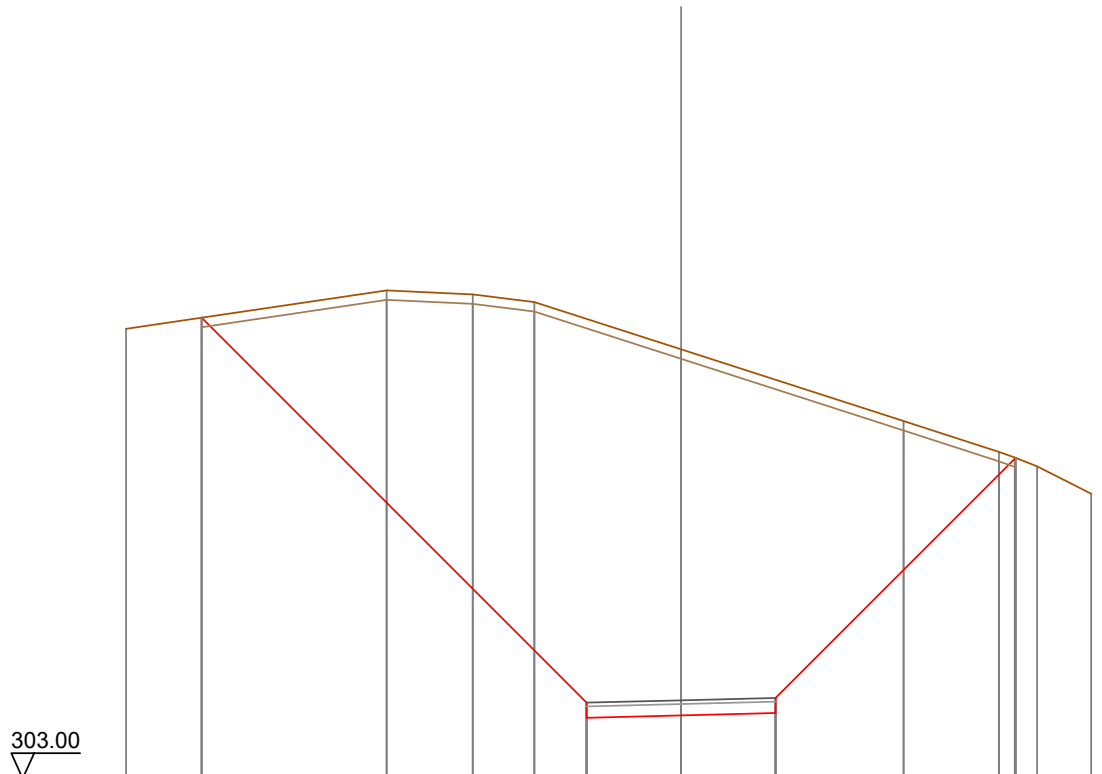

Quote Terreno		-314.89		-315.91	-315.80	-315.60		-314.35		-312.46	-311.64	-311.49	-311.26	-310.53
Quote Progetto			315.19				304.61	304.67	304.73			311.48		
Parziali				10.18			2.50	2.50		6.35				
Progressiva			-12.68				-2.50	0.00	2.50			8.85		
Dislivelli			0.00				-10.15	-9.68	-8.81			-0.00		

Sezione: 154
 Progressiva: 783.349
 Q. Progetto: 305.095

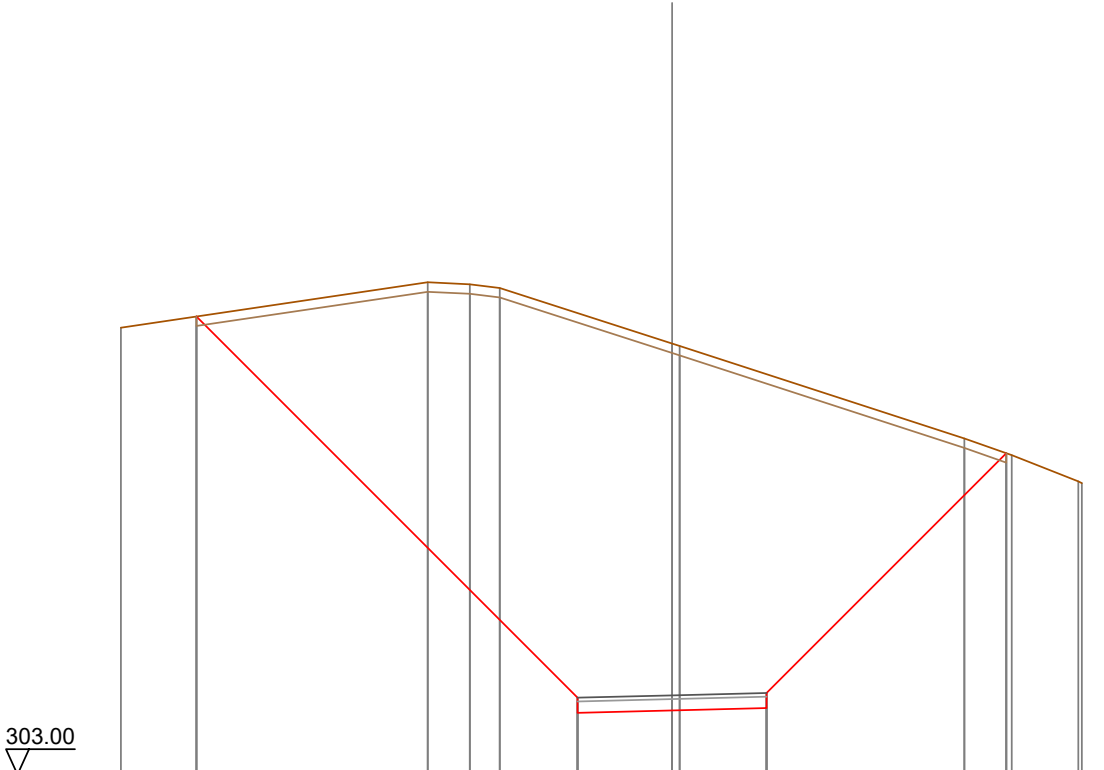

Quote Terreno	-314.82	-316.02	-315.97	-315.87	-314.40	-314.33	-311.89	-311.45	-310.75	-310.71
Quote Progetto		315.11			304.63	304.70	304.76	311.50		
Parziali		10.08			2.50	2.50	6.34			
Progressiva		-12.58			-2.50	0.00	2.50	8.84		
Dislivelli		0.00			-10.17	-9.70	-8.83	0.00		

Sezione: 155
 Progressiva: 790.000
 Q. Progetto: 305.275

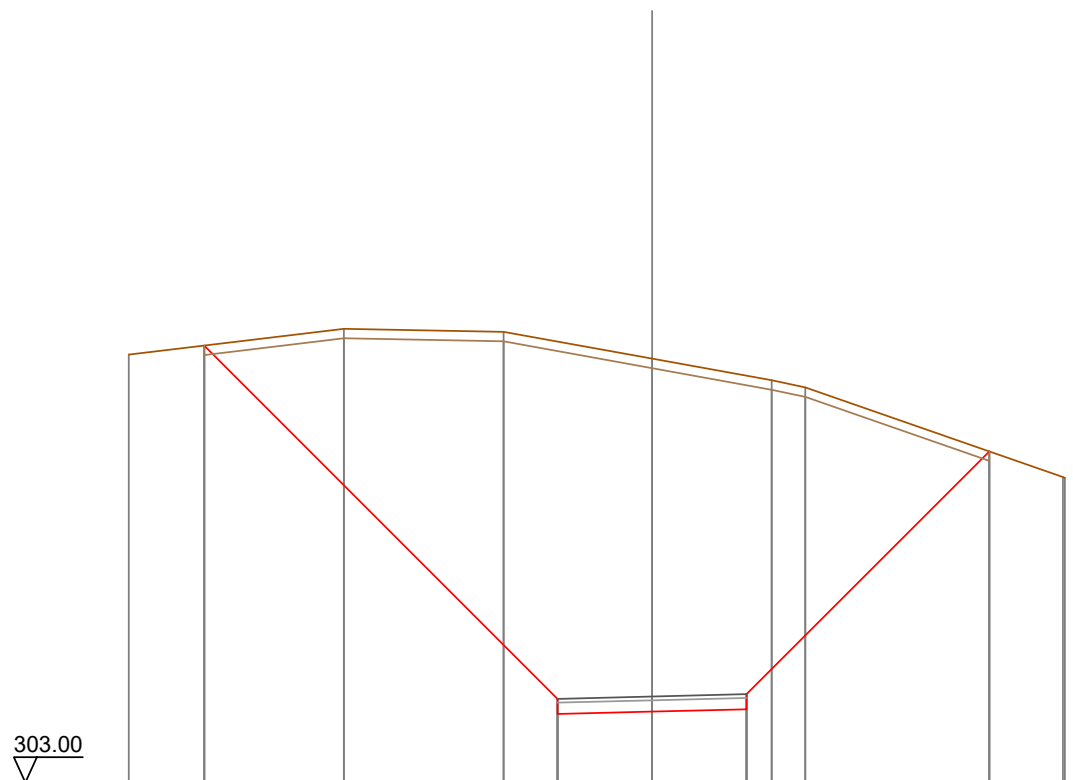

Quote Terreno		314.32		315.00		314.92		314.21		313.64		313.45		311.08	311.06
Quote Progetto		314.56				304.81		304.88		304.94				311.76	
Parziali			9.34		2.50	2.50		6.42							
Progressiva		-11.84			-2.50	0.00		2.50						8.92	
Dislivelli		0.00			-9.45	-9.34		-8.82						0.00	

Sezione: 156
 Progressiva: 800.001
 Q. Progetto: 305.546

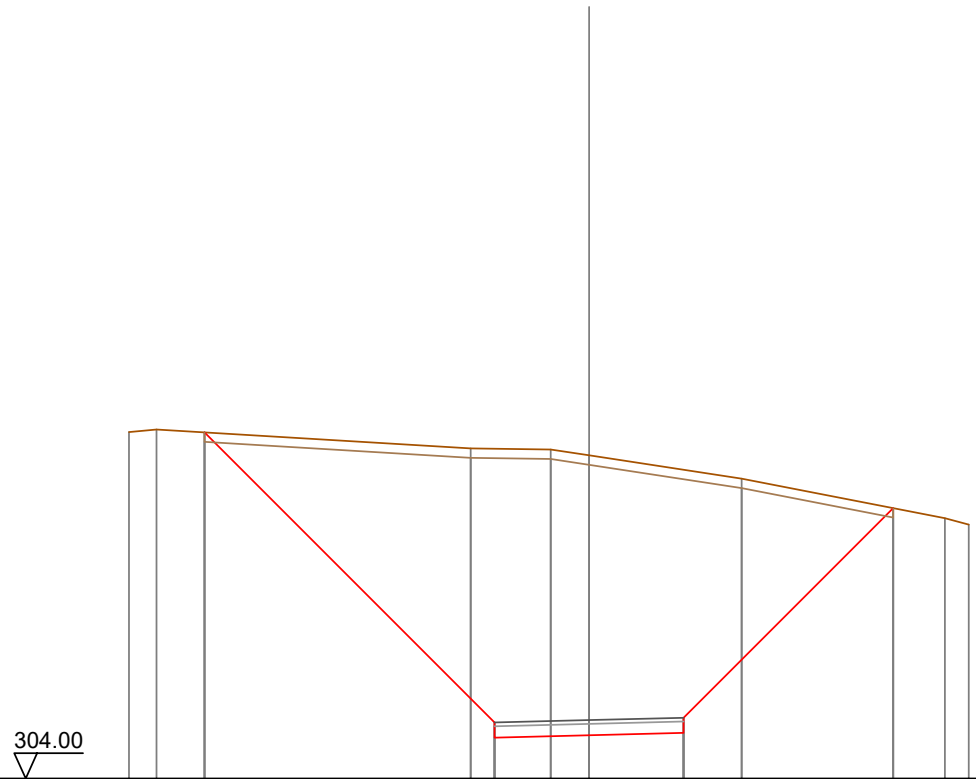

Quote Terreno		-313.16	-313.23			-312.73	-312.70	312.55		-311.93		-310.89	-310.71
Quote Progetto				313.15			305.08	305.15	305.21			311.15	
Parziali					7.67		2.50	2.50		5.54			
Progressiva				-10.17			-2.50	0.00	2.50			8.04	
Dislivelli				0.00			-7.24	-7.40	-6.96			0.00	

Sezione: 157
 Progressiva: 810.000
 Q. Progetto: 305.817

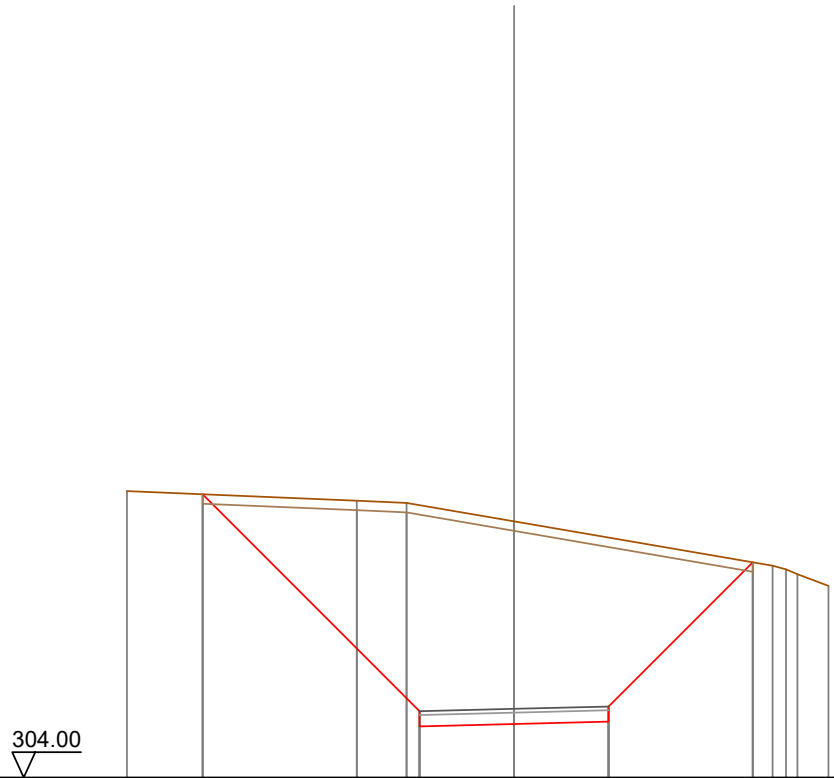

Quote Terreno		-311.58		-311.32	-311.26	310.77		-309.60	-309.38	-309.07
Quote Progetto			311.49		305.35	305.42	305.48		309.69	
Parziali				5.74		2.50	2.50		3.81	
Progressiva			-8.24		-2.50	0.00	2.50		6.31	
Dislivelli			-0.00		-5.45	-5.36	-4.87		0.00	

Sezione: 158
 Progressiva: 816.654
 Q. Progetto: 305.997

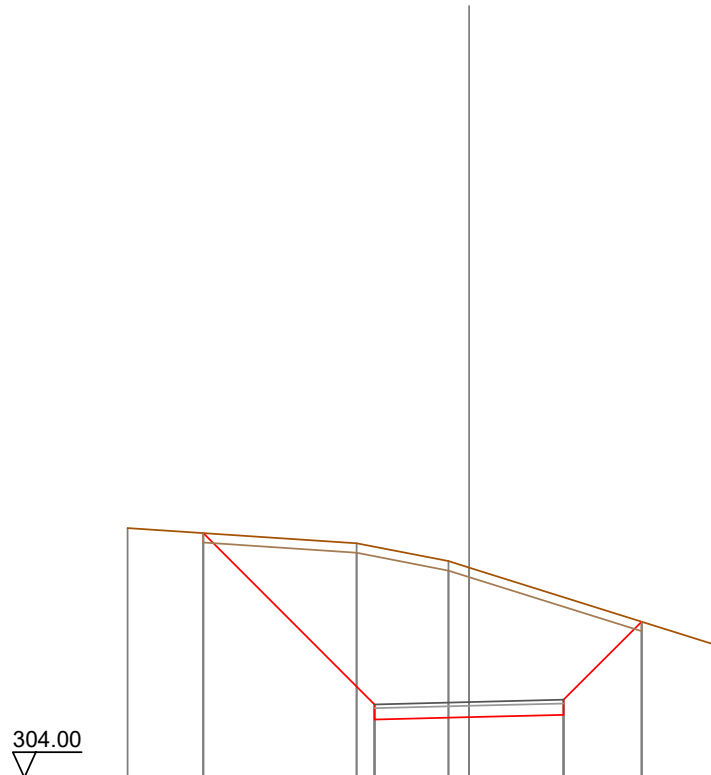

Quote Terreno	-310.60	-310.47	-310.20	-309.72	-309.55	-305.66	-308.12	-307.49
Quote Progetto		-310.47	-305.53	-305.60	-305.66	-308.12		
Parziali		4.53	2.50	2.50	2.06			
Progressiva		-7.03	-2.50	0.00	2.50	4.56		
Dislivelli		-0.00	-4.17	-3.96	-3.11	0.00		

Sezione: 159
 Progressiva: 818.851
 Q. Progetto: 306.056

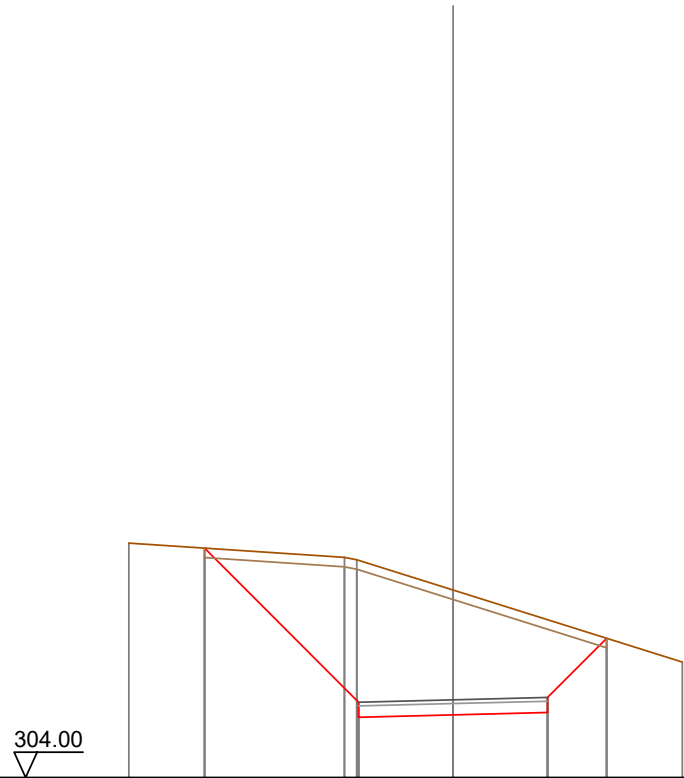

Quote Terreno		-310.20		309.82 309.76	308.96		307.05
Quote Progetto			310.07	305.59	305.66	305.72	307.68
Parziali			4.07	2.50	2.50	1.56	
Progressiva			-6.57	-2.50	0.00	2.50	4.06
Dislivelli			0.00	-3.75	-3.30	-2.45	-0.00

Sezione: 160
 Progressiva: 820.000
 Q. Progetto: 306.087

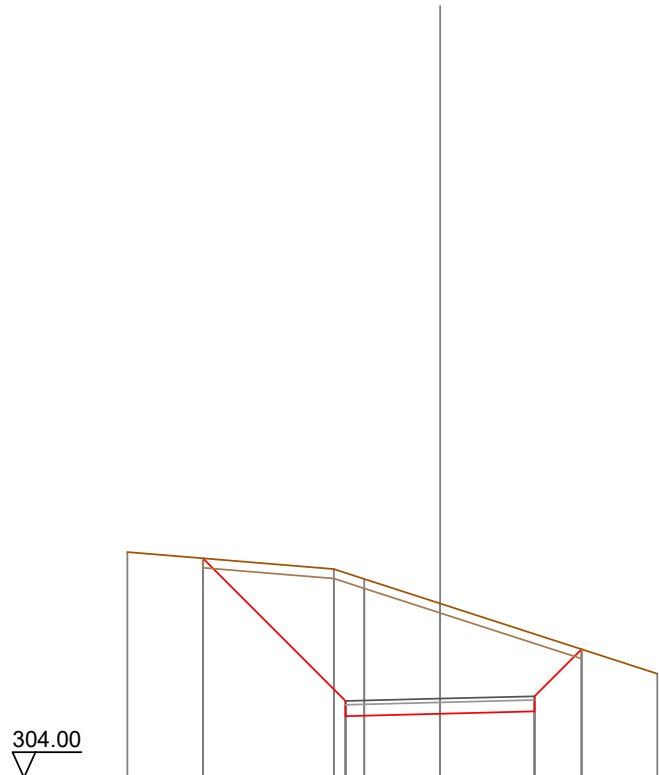

Quote Terreno	-309.96		-309.52	-309.25	308.60		305.75	307.99	-306.75
Quote Progetto		309.80	305.62		305.69		305.75	307.99	
Parziali			3.77	2.50	2.50		1.24		
Progressiva		-6.27	-2.50		0.00		2.50	3.74	
Dislivelli		-0.00	-3.39		-2.92		-2.05	-0.00	

Sezione: 161
 Progressiva: 830.000
 Q. Progetto: 306.358

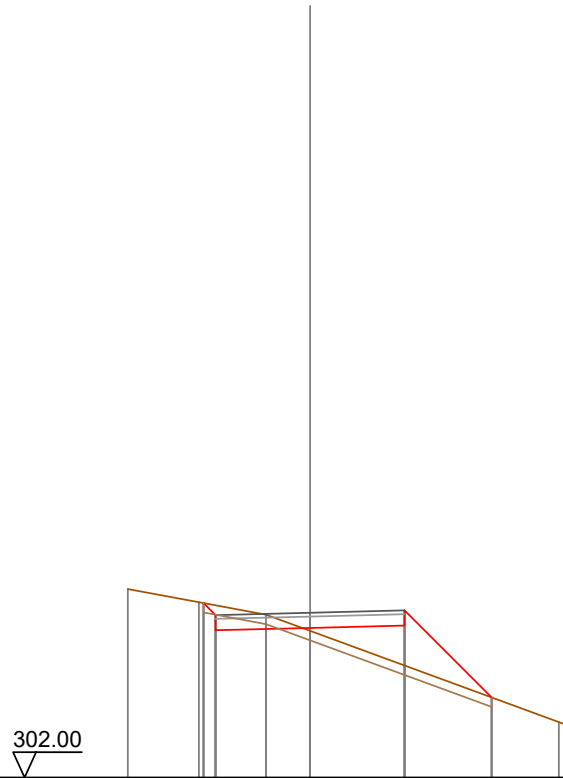

Quote Terreno		-306.99	-306.64	-306.31	-305.88			-303.47	-303.39
Quote Progetto			-306.61	-305.90	-305.96	-306.02		-304.12	
Parziali			0.32	2.50	2.50	2.30			
Progressiva			-2.82	-2.50	0.00	2.50	4.80		
Dislivelli			-0.00	-0.26	0.08	1.06	0.00		

Sezione: 162
 Progressiva: 831.882
 Q. Progetto: 306.409

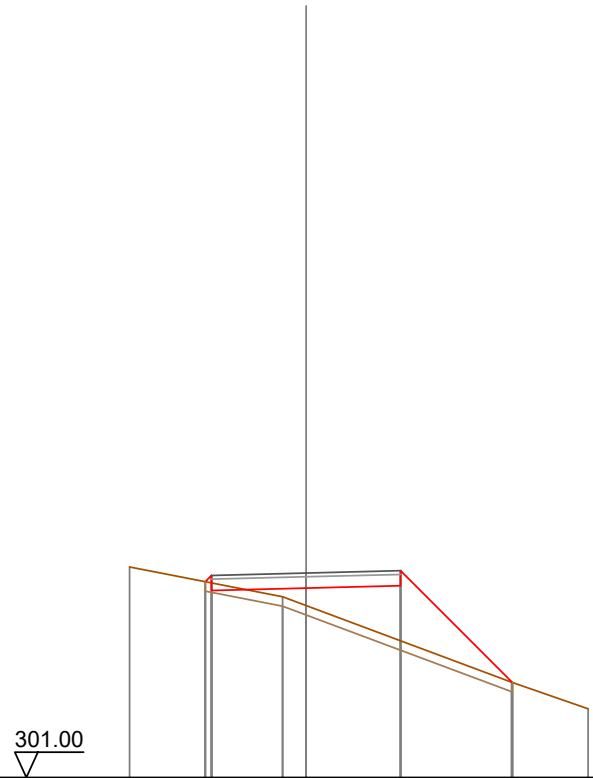

Quote Terreno		-306.57		-305.78	-305.55		-303.52	-302.82
Quote Progetto			306.18	305.95	306.01	306.07	303.51	
Parziali			2.50	2.50	2.96			
Progressiva			-2.67	-2.50	0.00	2.50	5.46	
Dislivelli			0.00	0.20	0.46	1.45	-0.00	

Sezione: 163
 Progressiva: 840.000
 Q. Progetto: 306.629

300.00

Quote Terreno		-305.23			303.93	303.90														
Quote Progetto			304.80		306.17		306.23		306.29							302.03				
Parziali				1.76	2.50		2.50		4.66											
Progressiva			4.26		-2.50		0.00		2.50						7.16					
Dislivelli			0.00		2.14		2.33		2.79						0.00					

Sezione: 164
 Progressiva: 844.913
 Q. Progetto: 306.762

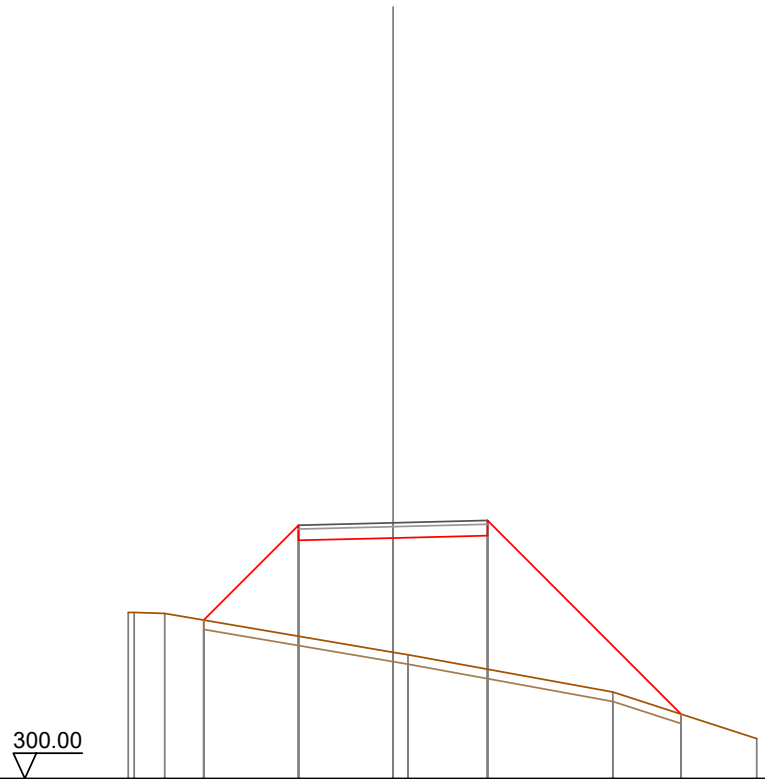

Quote Terreno		304.39	304.39	304.37		303.34	303.27		302.29		301.06
Quote Progetto			304.19		306.30		306.36		306.42		301.71
Parziali					2.51		2.50		2.50		5.12
Progressiva			-5.01		-2.50		0.00		2.50		7.62
Dislivelli			-0.00		2.93		3.02		3.53		-0.00

Sezione: 165
 Progressiva: 857.545
 Q. Progetto: 307.104

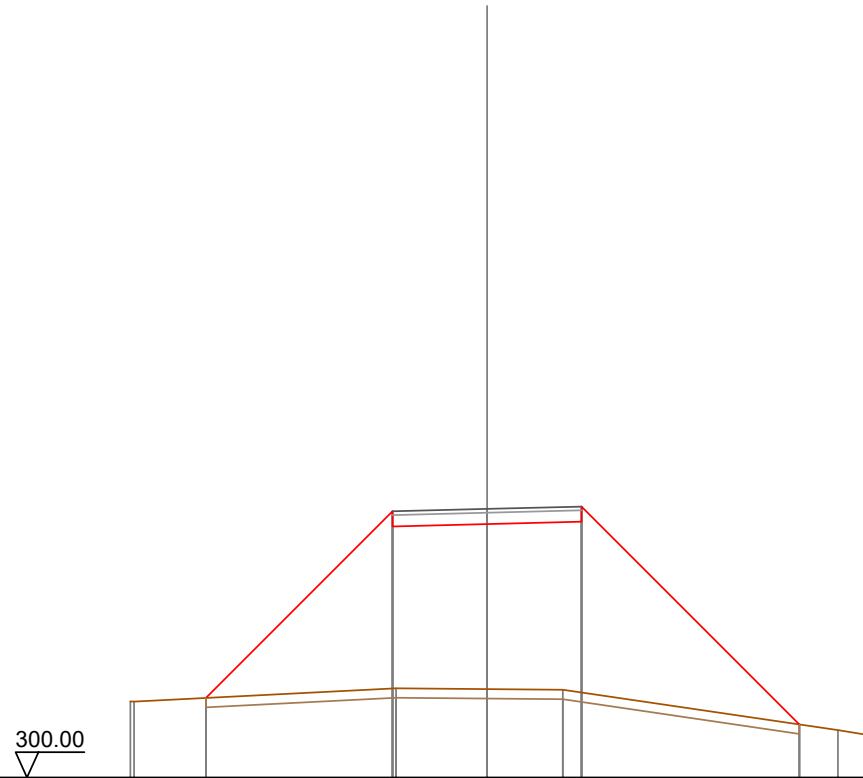

Quote Terreno	302.01	302.01		302.36	302.34	302.32		301.26	301.10
Quote Progetto			302.10	306.64	306.70	306.77		301.40	
Parziali				4.94	2.50	2.50		5.76	
Progressiva			-7.44	-2.50	0.00	2.50		8.26	
Dislivelli			0.00	4.69	4.37	4.52		0.00	

Sezione: 166
 Progressiva: 858.697
 Q. Progetto: 307.135

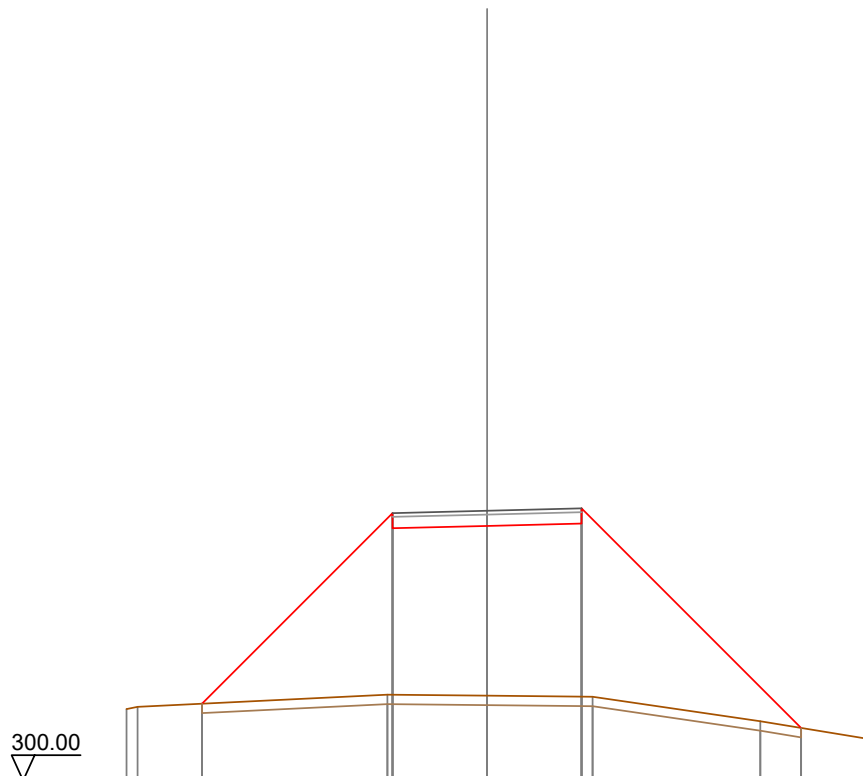

Quote Terreno	301.89	301.95	302.27	302.25	302.22	301.57	301.07
Quote Progetto		302.03	306.67	306.73	306.80	301.39	
Parziali		5.04	2.50	2.50	5.80		
Progressiva		-7.54	-2.50	0.00	2.50	8.30	
Dislivelli		0.00	4.80	4.49	4.58	0.00	

Sezione: 167
 Progressiva: 859.848
 Q. Progetto: 307.166

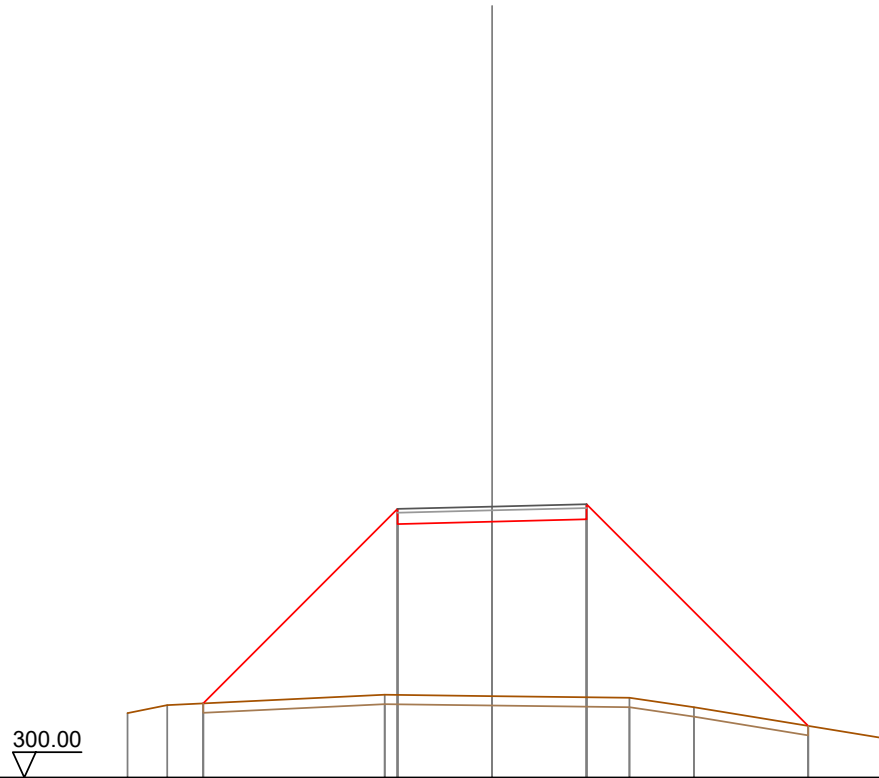

Quote Terreno	-301.70	-301.92	-302.19	-302.15	-302.11	-301.86	-301.04
Quote Progetto		301.96	306.70	306.77	306.83		301.37
Parziali			5.14	2.50	2.50	5.86	
Progressiva		-7.64	-2.50	0.00	2.50		8.36
Dislivelli		-0.00	4.92	4.61	4.70		0.00

Sezione: 168
 Progressiva: 880.000
 Q. Progetto: 307.711

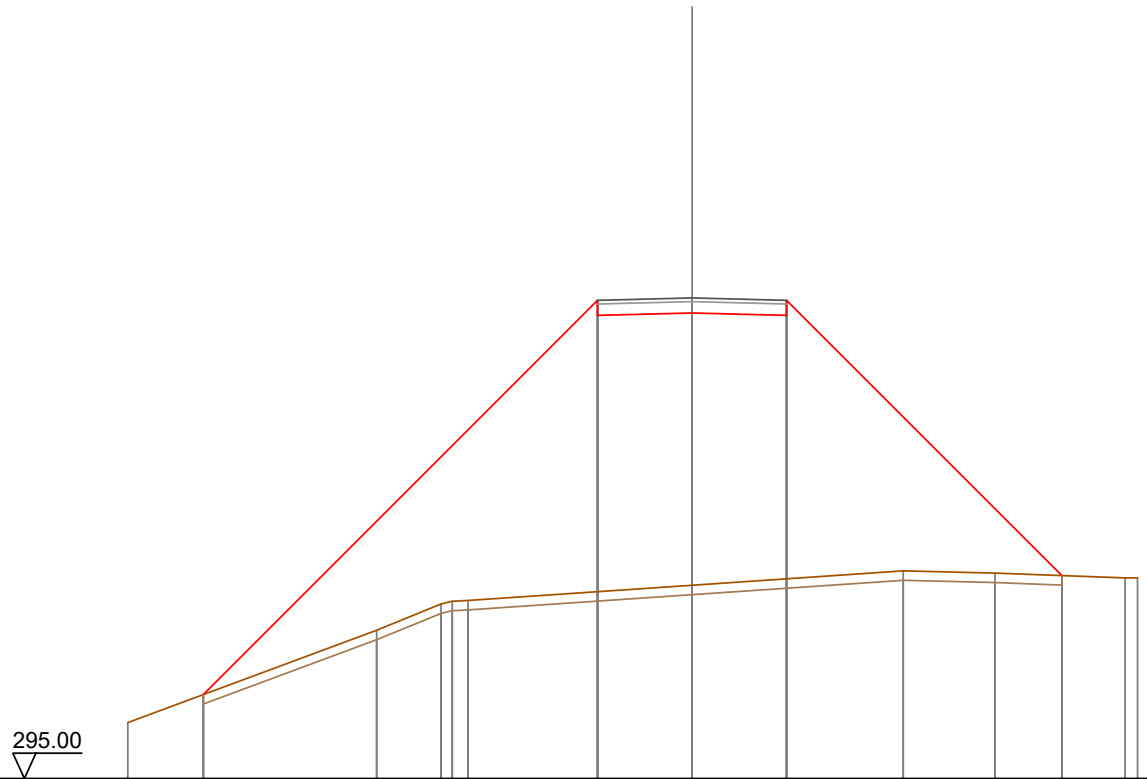

Quote Terreno	296.48	298.92	299.61	299.69	299.71	300.11	300.49	300.43	300.30	300.30
Quote Progetto	297.22					307.25	307.31	307.25		300.37
Parziali		10.43			2.50	2.50		7.28		
Progressiva	-12.93				-2.50	0.00	2.50		9.78	
Dislivelli	0.00				7.71	7.20	6.97		0.00	

Sezione: 169
 Progressiva: 893.406
 Q. Progetto: 308.074

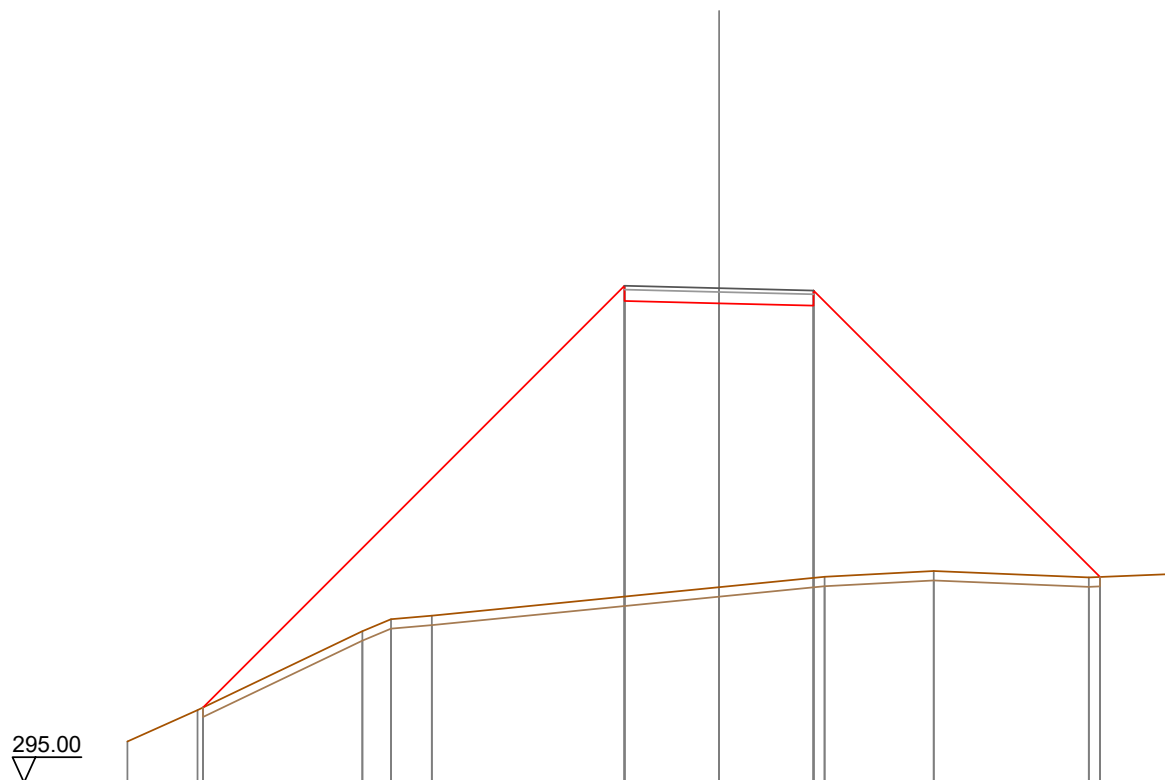

Quote Terreno	296.09	296.92	299.00	299.32	299.41		300.17	300.44	300.59	300.42	300.52
Quote Progetto		296.99					307.74	307.67		300.44	
Parziali			11.15				2.50	2.50	7.57		
Progressiva		-13.65					-2.50	0.00		10.07	
Dislivelli		-0.00					8.22	7.51		-0.00	

Sezione: 170
 Progressiva: 895.909
 Q. Progetto: 308.142

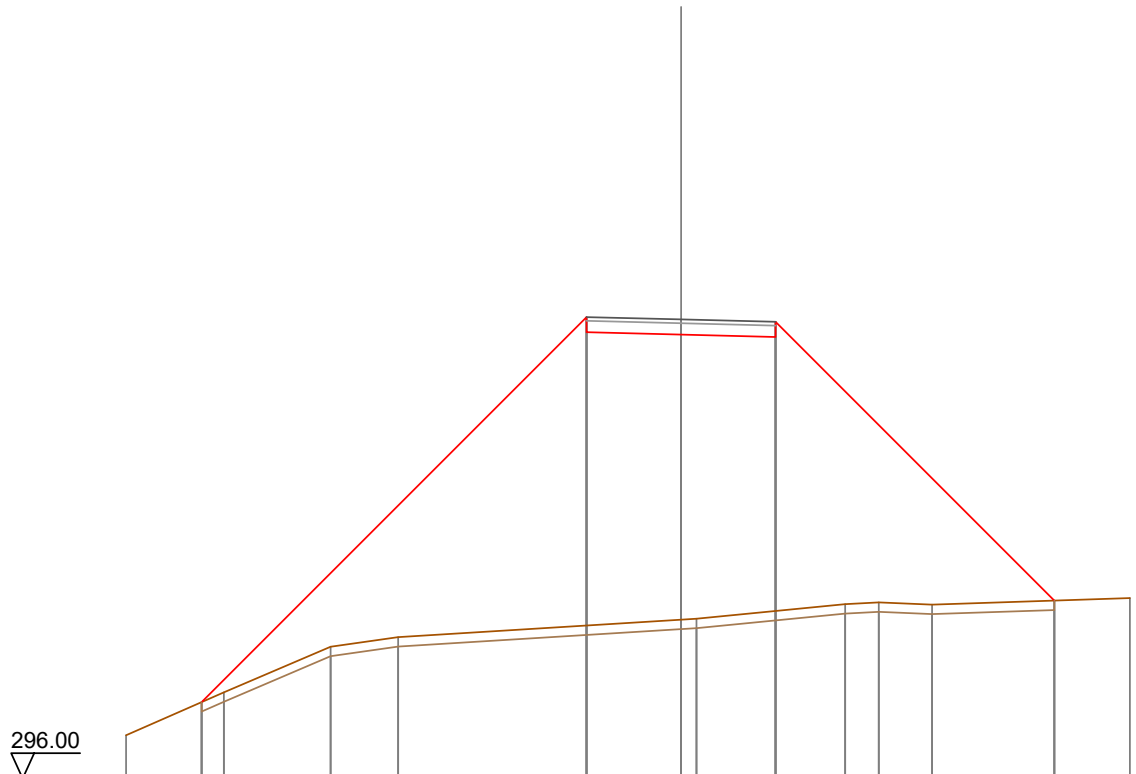

Quote Terreno	-297.15	-298.28	-299.49	-299.74		300.20	-300.23		-300.61	-300.66	-300.60		-300.77
Quote Progetto		298.02			307.80	307.74		307.68				300.71	
Parziali			10.18		2.50	2.50		7.37					
Progressiva		-12.68			-2.50	0.00		2.50				9.87	
Dislivelli		0.00			8.16	7.54		7.25				0.00	

Sezione: 171
 Progressiva: 898.412
 Q. Progetto: 308.210

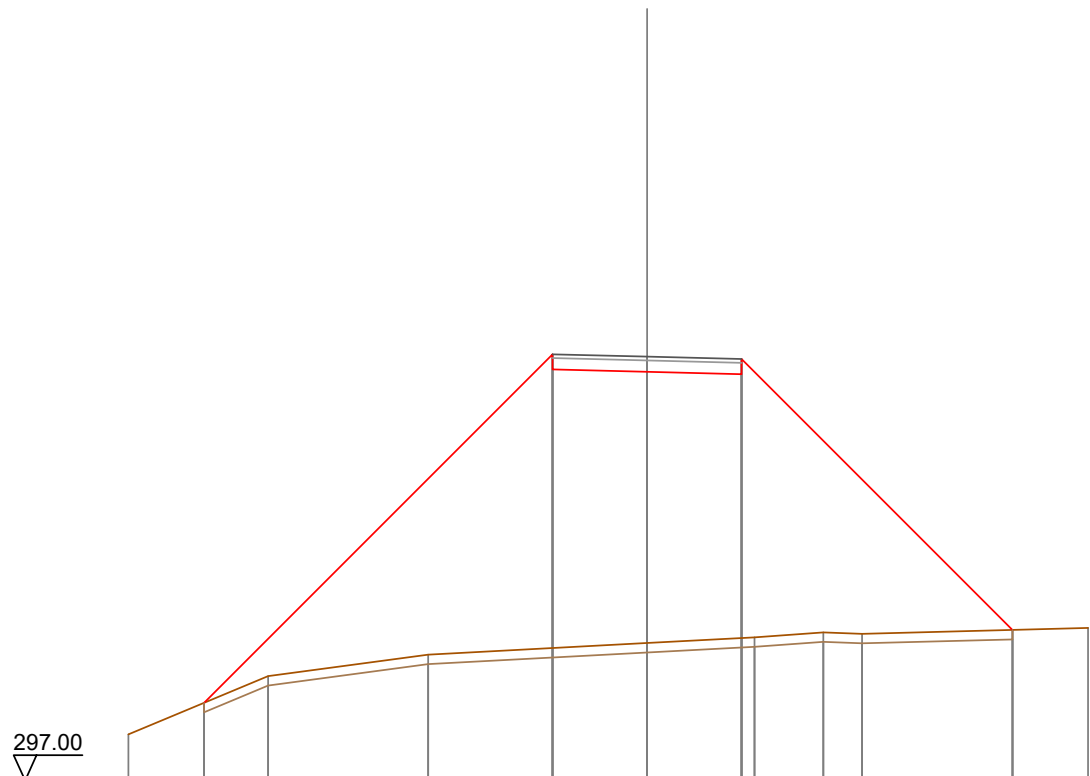

Quote Terreno		-298.22		-299.76		-300.33		-300.64		-300.79		-300.92		-300.88		-301.04
Quote Progetto			299.05				307.87		307.81		307.75					300.98
Parziali				9.22			2.50	2.50			7.16					
Progressiva			-11.72				-2.50	0.00		2.50					9.66	
Dislivelli			0.00				7.77	7.17		6.98					0.00	

Sezione: 172
 Progressiva: 900.000
 Q. Progetto: 308.253

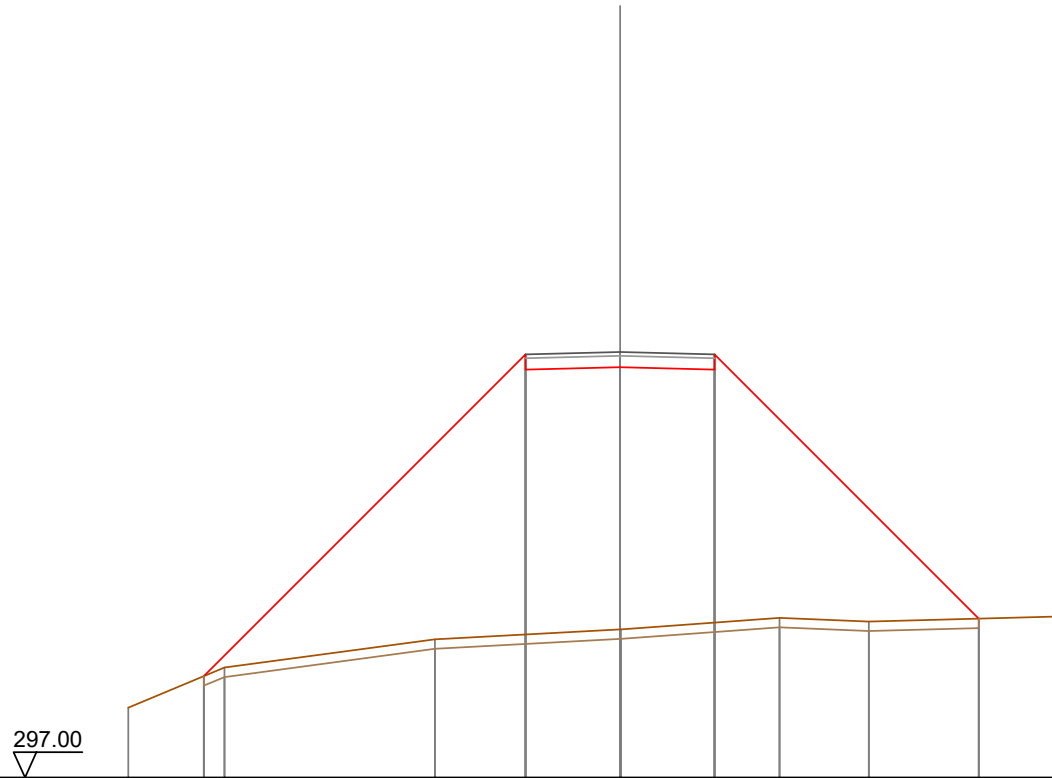

Quote Terreno		-298.85	-299.91	-300.66	-300.92	-300.92	-301.22	-301.13	-301.25
Quote Progetto			299.68		307.79	307.85	307.79		301.20
Parziali				8.51	2.50	2.50		6.99	
Progressiva			-11.01		-2.50	0.00	2.50		9.49
Dislivelli			-0.00		7.41	6.94	6.69		-0.00

Sezione: 173
 Progressiva: 918.392
 Q. Progetto: 308.751

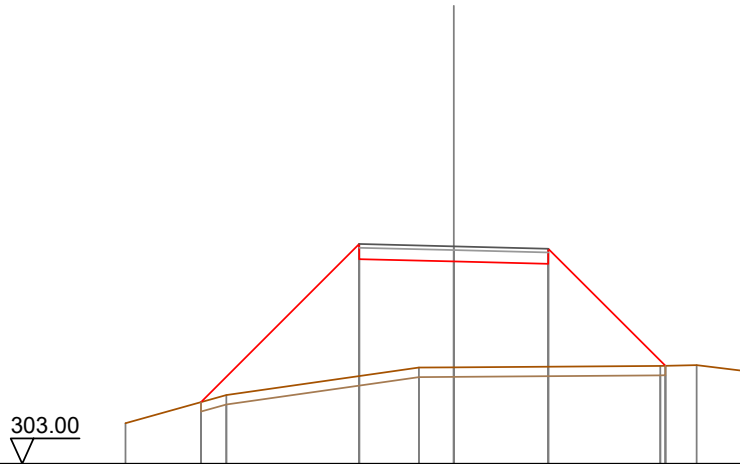

Quote Terreno	-304.07	-304.82	-305.54	-305.55	-305.59	-305.61	-305.47
Quote Progetto		304.63	308.41	308.35	308.29	305.59	
Parziali		4.18	2.50	2.50	3.10		
Progressiva		-6.68	-2.50	0.00	2.50	5.60	
Dislivelli		0.00	3.49	2.80	2.72	-0.00	

Sezione: 174
 Progressiva: 918.682
 Q. Progetto: 308.758

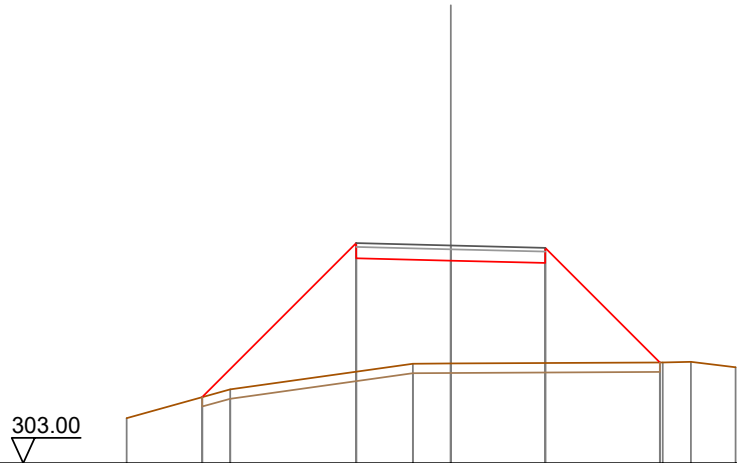

Quote Terreno	-304.19	-304.95	-305.63	-305.64	-305.67	-305.68	-305.54
Quote Progetto		304.75	308.42	308.36	308.30	305.67	
Parziali		4.07	2.50	2.50	3.03		
Progressiva		-6.57	-2.50	0.00	2.50	5.53	
Dislivelli		0.00	3.40	2.72	2.65	0.00	

Sezione: 175
 Progressiva: 918.972
 Q. Progetto: 308.766

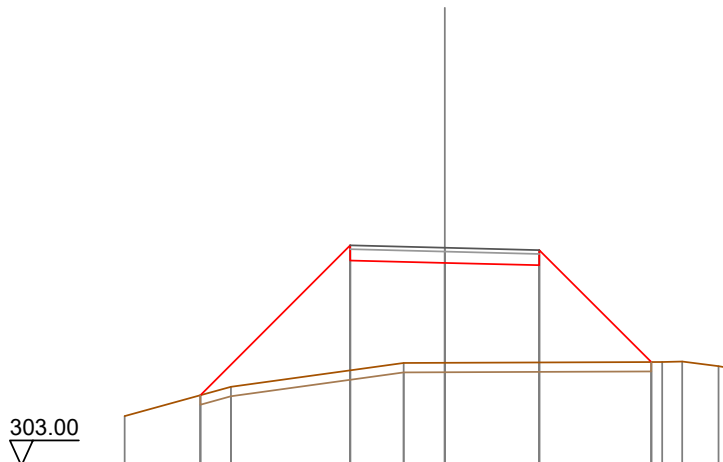

Quote Terreno	304.31	305.09	305.72	305.72		305.74	305.75	305.63	305.59
Quote Progetto		304.87	308.43	308.37	308.30	305.74			
Parziali		3.96	2.50	2.50	2.96				
Progressiva		-6.46	-2.50	0.00	2.50	5.46			
Dislivelli		-0.00	3.30	2.64	2.57	0.00			

Sezione: 176
 Progressiva: 920.000
 Q. Progetto: 308.794

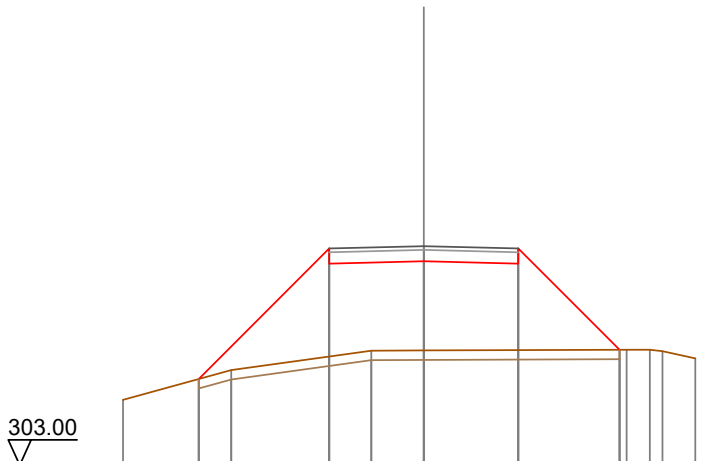

Quote Terreno	304.73	305.52	306.03	306.03		306.05	306.05	306.02	305.82
Quote Progetto		305.28	308.33	308.39	308.33	306.05			
Parziali		3.45	2.50	2.50	2.68				
Progressiva		-5.95	-2.50	0.00	2.50	5.18			
Dislivelli		-0.00	2.86	2.36	2.29	-0.00			

Sezione: 177
 Progressiva: 940.000
 Q. Progetto: 309.483

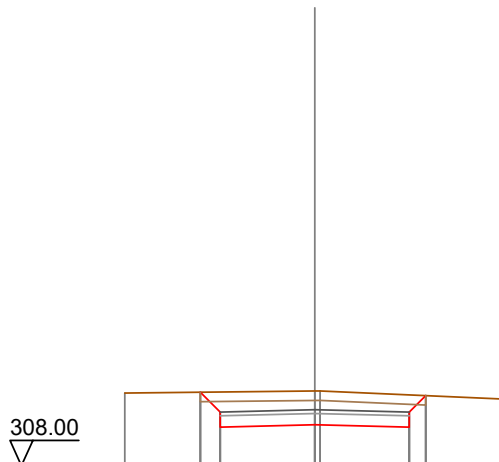

Quote Terreno	-309.92		309.98 309.98		-309.76
Quote Progetto		309.94 309.02	309.08	309.02 309.85	
Parziali		0.52 2.50	2.50	0.43	
Progressiva		-3.02 -2.50	0.00	2.50 2.93	
Dislivelli		0.00 -0.53	-0.89	-0.85 0.00	

Sezione: 178
 Progressiva: 958.326
 Q. Progetto: 310.763

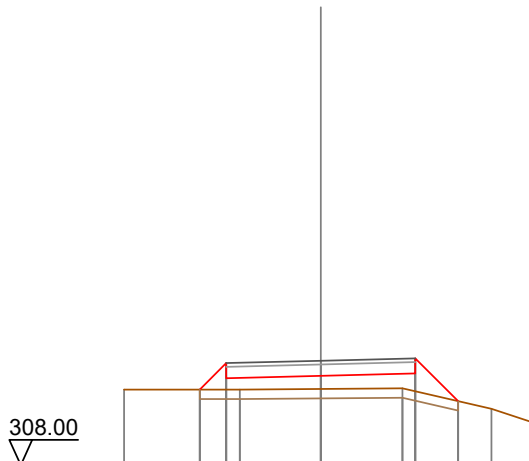

Quote Terreno	-310.00		310.02		-309.49 -308.12
Quote Progetto		310.00 310.30	310.36	310.43 309.69	
Parziali		0.70 2.50	2.50	1.13	
Progressiva		-3.20 -2.50	0.00	2.50 3.63	
Dislivelli		0.00 0.70	0.35	0.47 -0.00	

Sezione: 179
 Progressiva: 958.681
 Q. Progetto: 310.795

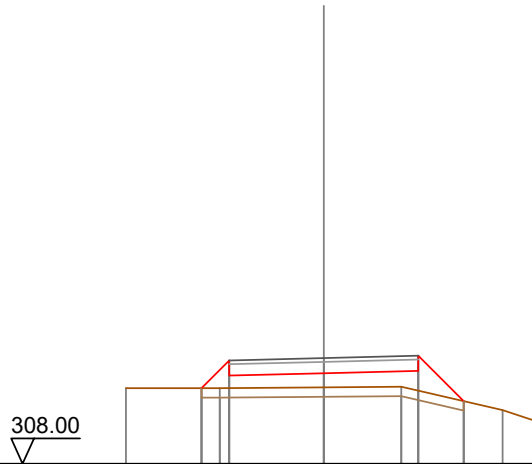

Quote Terreno	310.00	310.00	310.02	310.04	309.42	309.10
Quote Progetto		310.00	310.33	310.39	310.46	309.66
Parziali		0.73	2.50	2.50	1.20	
Progressiva		-3.23	-2.50	0.00	2.50	3.70
Dislivelli		-0.00	0.73	0.37	0.52	-0.00

Sezione: 180
 Progressiva: 959.036
 Q. Progetto: 310.826

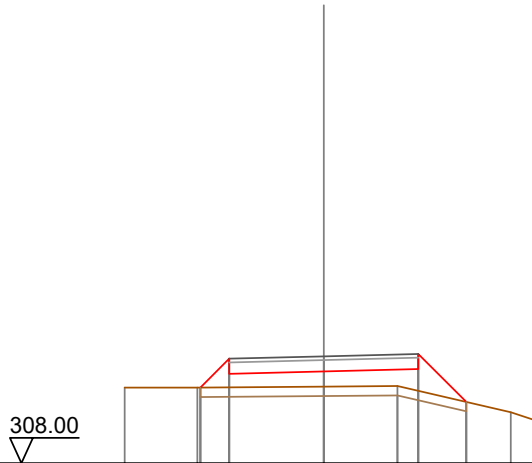

Quote Terreno	310.00	310.00	310.03	310.04	309.35	309.08
Quote Progetto		310.00	310.36	310.43	310.49	309.62
Parziali		0.76	2.50	2.50	1.27	
Progressiva		-3.26	-2.50	0.00	2.50	3.77
Dislivelli		-0.00	0.76	0.40	0.57	0.00

Sezione: 181
 Progressiva: 960.000
 Q. Progetto: 310.914

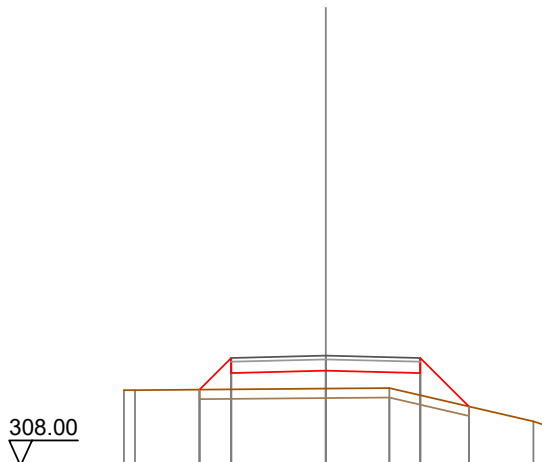

Quote Terreno	310.00	310.00		310.04	310.05		309.17	309.08
Quote Progetto		310.01	310.45	310.51	310.45	309.57		
Parziali		0.84	2.50	2.50	1.28			
Progressiva		-3.34	-2.50	0.00	2.50	3.78		
Dislivelli		0.00	0.83	0.47	0.59	-0.00		

Sezione: 182
 Progressiva: 980.000
 Q. Progetto: 313.155

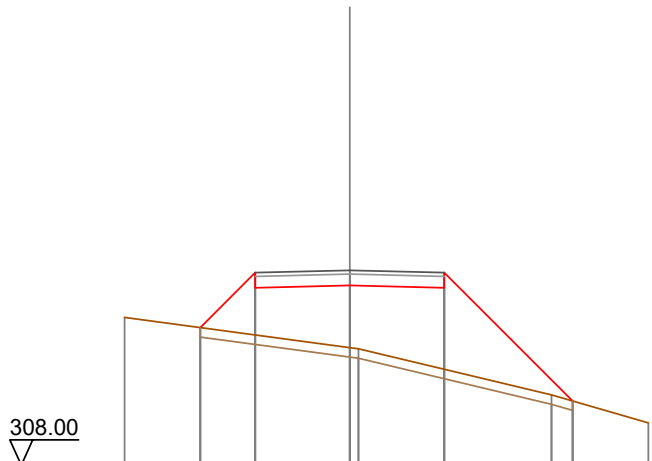

Quote Terreno	311.91			311.11	311.08		309.86	309.12
Quote Progetto		311.64	312.69	312.76	312.69	309.70		
Parziali		1.45	2.50	2.50	3.40			
Progressiva		-3.95	-2.50	0.00	2.50	5.90		
Dislivelli		0.00	1.65	1.65	2.16	-0.00		

Sezione: 183
 Progressiva: 988.799
 Q. Progetto: 314.401

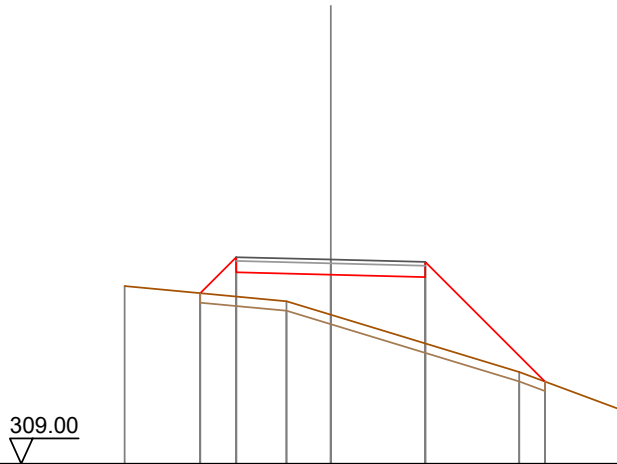

Quote Terreno		-313.70		-313.30	-312.94		-311.43	-310.43
Quote Progetto			313.51	314.06	314.00	313.94	311.17	
Parziali			0.95	2.50	2.50	3.16		
Progressiva			-3.45	-2.50	0.00	2.50	5.66	
Dislivelli			0.00	1.04	1.06	1.76	0.00	

Sezione: 184
 Progressiva: 990.000
 Q. Progetto: 314.583

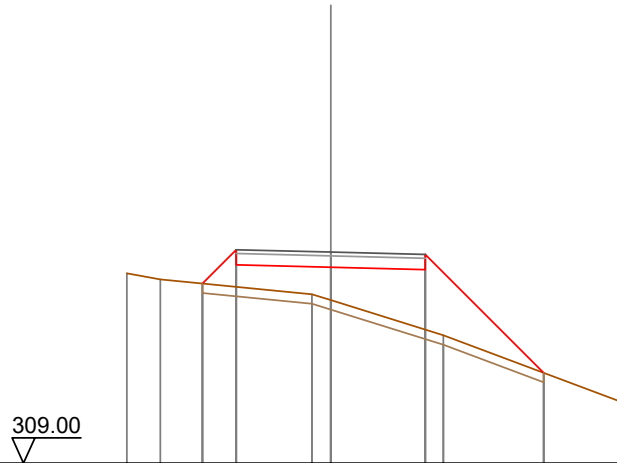

Quote Terreno		-314.02	-313.86		-313.47	-313.31	-312.39	-310.64
Quote Progetto			313.75	314.25	314.18	314.12	311.39	
Parziali			0.89	2.50	2.50	3.13		
Progressiva			-3.39	-2.50	0.00	2.50	5.63	
Dislivelli			-0.00	0.98	0.87	1.59	0.00	

Sezione: 185
 Progressiva: 994.755
 Q. Progetto: 315.334

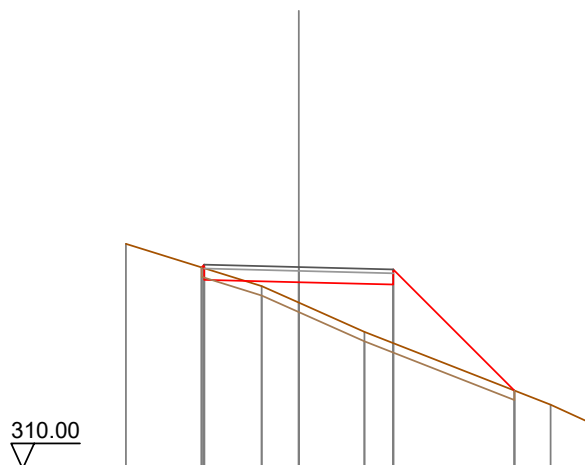

Quote Terreno	-315.95	-314.83	-314.40	-313.62	-311.69	-311.22
Quote Progetto	315.33	315.00	314.93	314.87	312.07	
Parziali		2.50	2.50	3.20		
Progressiva	-2.57	-2.50	0.00	2.50	5.70	
Dislivelli	0.00	0.09	0.54	1.55	0.00	

Sezione: 186
 Progressiva: 1000.000
 Q. Progetto: 316.218

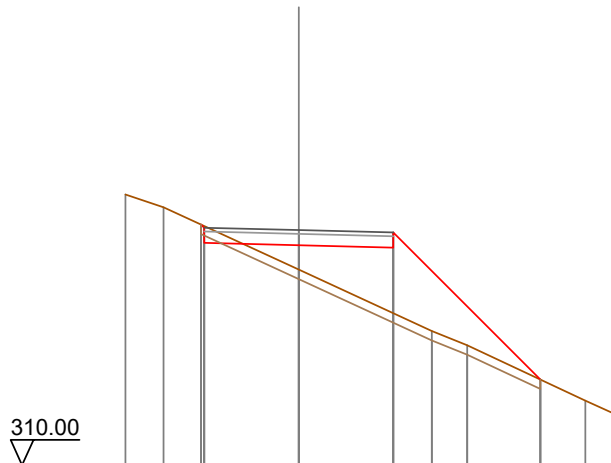

Quote Terreno	-317.16	-316.82	-315.17	-313.55	-313.17	-311.71	-311.34
Quote Progetto	316.37	315.88	315.82	315.76	312.26		
Parziali		2.50	2.50	3.89			
Progressiva	-2.58	-2.50	0.00	2.50	6.39		
Dislivelli	-0.00	-0.05	0.65	1.74	0.00		

Sezione: 187
 Progressiva: 1000.710
 Q. Progetto: 316.342

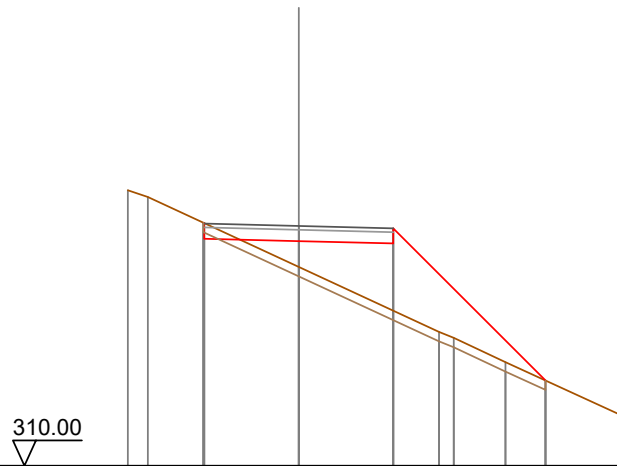

Quote Terreno	-317.29	-317.11		315.26		-313.54	-313.38	-312.74	-311.34
Quote Progetto		316.43	316.00	315.94	315.88			312.26	
Parziali			2.50	2.50		4.02			
Progressiva		-2.52	-2.50	0.00	2.50			6.52	
Dislivelli		0.00	-0.01	0.68	1.78			-0.00	

Sezione: 188
 Progressiva: 1018.114
 Q. Progetto: 319.714

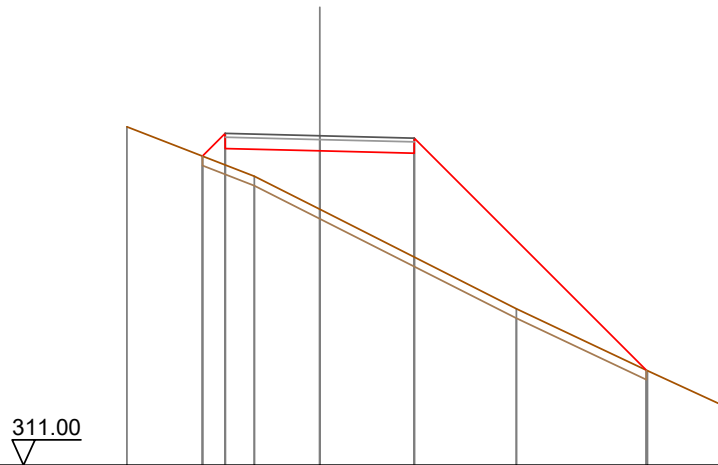

Quote Terreno	-319.95		318.64	317.77		-315.14	313.50	312.61	312.59
Quote Progetto		319.18	319.38	319.31	319.25		313.51		
Parziali		0.60	2.50	2.50		6.14			
Progressiva		-3.10	-2.50	0.00	2.50		8.64		
Dislivelli		0.00	0.83	1.54	2.75		0.00		

Sezione: 189
 Progressiva: 1018.590
 Q. Progetto: 319.815

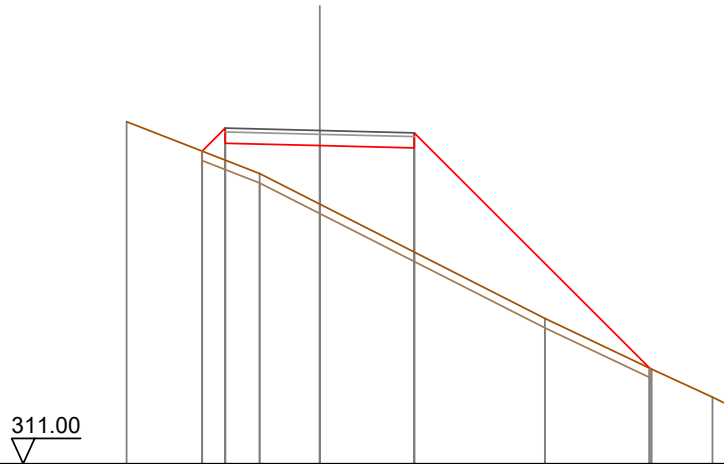

Quote Terreno	-320.05	-319.27	-318.68	-317.87	-314.84	-313.50	-312.76	-312.60
Quote Progetto		319.27	319.48	319.42	319.35	313.53		
Parziali		0.61	2.50	2.50	6.22			
Progressiva		-3.11	-2.50	0.00	2.50	8.72		
Dislivelli		0.00	0.85	1.55	2.76	0.00		

Sezione: 190
 Progressiva: 1019.066
 Q. Progetto: 319.917

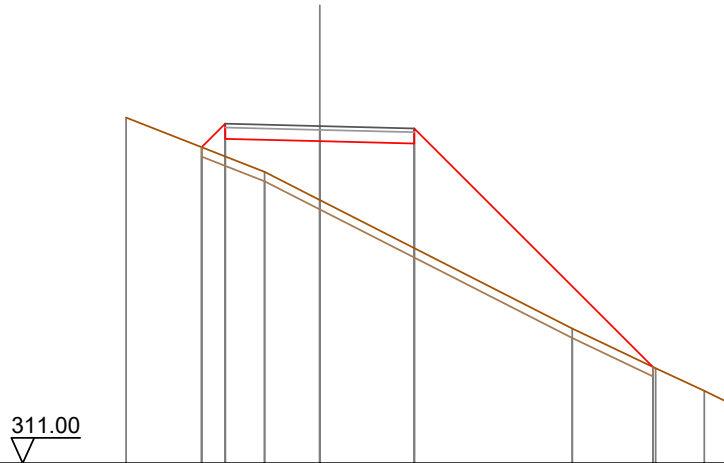

Quote Terreno	-320.14	-319.36	-318.71	-317.96	-314.56	-313.51	-312.91	-312.60
Quote Progetto		319.36	319.58	319.52	319.45	313.55		
Parziali		0.62	2.50	2.50	6.31			
Progressiva		-3.12	-2.50	0.00	2.50	8.81		
Dislivelli		0.00	0.87	1.55	2.77	0.00		

Sezione: 191
 Progressiva: 1020.000
 Q. Progetto: 320.118

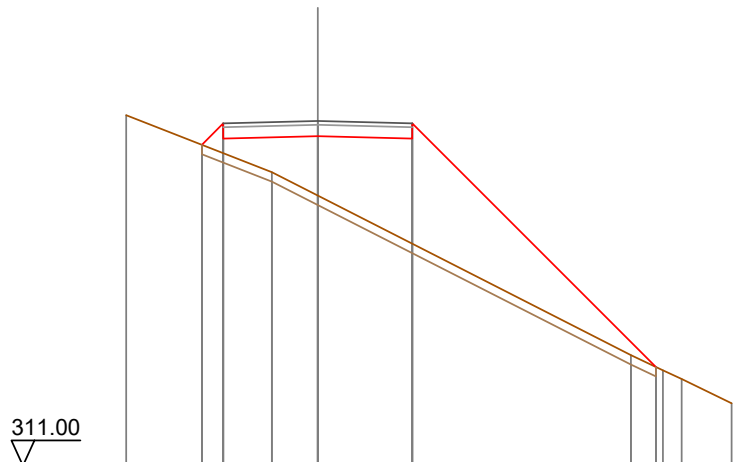

Quote Terreno	-320.27		-318.77	-318.15		-313.93	-313.52	-313.29	-312.65
Quote Progetto		319.49	319.66	319.72	319.66		313.61		
Parziali		0.56	2.50	2.50	6.44				
Progressiva		-3.06	-2.50	0.00	2.50		8.94		
Dislivelli		-0.00	0.79	1.57	2.78		0.00		

Sezione: 192
 Progressiva: 1038.664
 Q. Progetto: 324.254

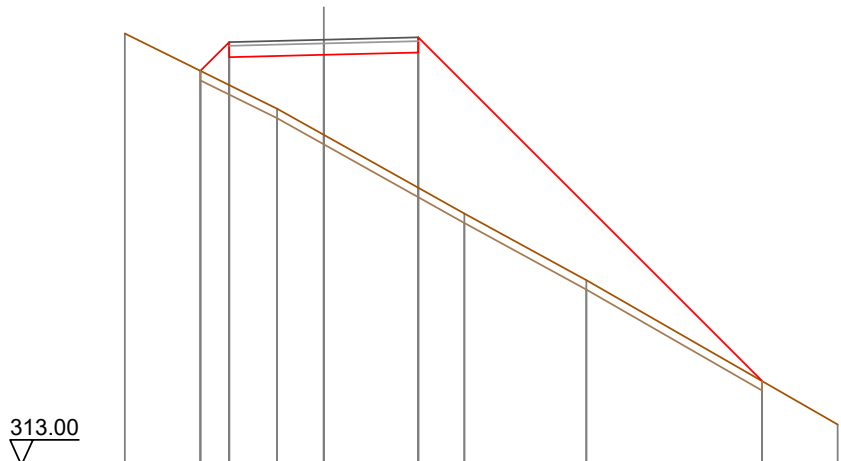

Quote Terreno	-324.42		-322.43	-321.74	-319.65	-317.89		-314.08
Quote Progetto		323.43	323.79	323.85	323.92		315.23	
Parziali		0.76	2.50	2.50	9.09			
Progressiva		-3.26	-2.50	0.00	2.50		11.59	
Dislivelli		0.00	1.14	2.12	3.58		0.00	

Sezione: 193
 Progressiva: 1040.000
 Q. Progetto: 324.551

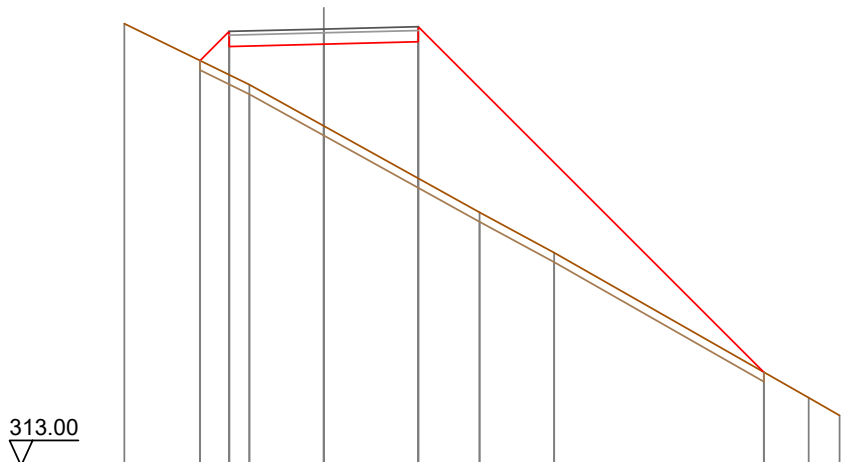

Quote Terreno	-324.69	-323.08	-321.99	-319.70	-318.63	-314.80	-314.33
Quote Progetto		323.72	324.09	324.15	324.21	315.47	
Parziali		0.77	2.50	2.50	9.14		
Progressiva		-3.27	-2.50	0.00	2.50	11.64	
Dislivelli		0.00	1.15	2.16	3.61	0.00	

Sezione: 194
 Progressiva: 1041.802
 Q. Progetto: 324.951

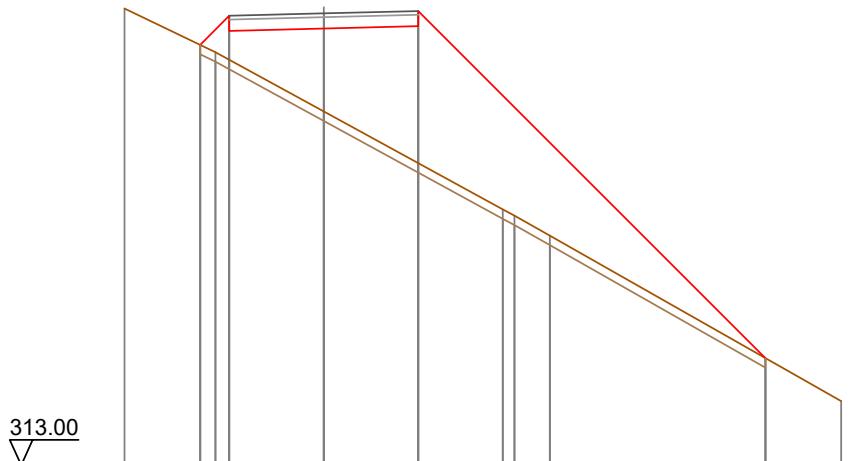

Quote Terreno	-325.08	-323.92	-322.36	-319.76	-319.60	-319.07	-314.69
Quote Progetto		324.12	324.49	324.55	324.61	315.83	
Parziali		0.77	2.50	2.50	9.18		
Progressiva		-3.27	-2.50	0.00	2.50	11.68	
Dislivelli		0.00	1.16	2.19	3.62	-0.00	

Sezione: 195
 Progressiva: 1044.939
 Q. Progetto: 325.647

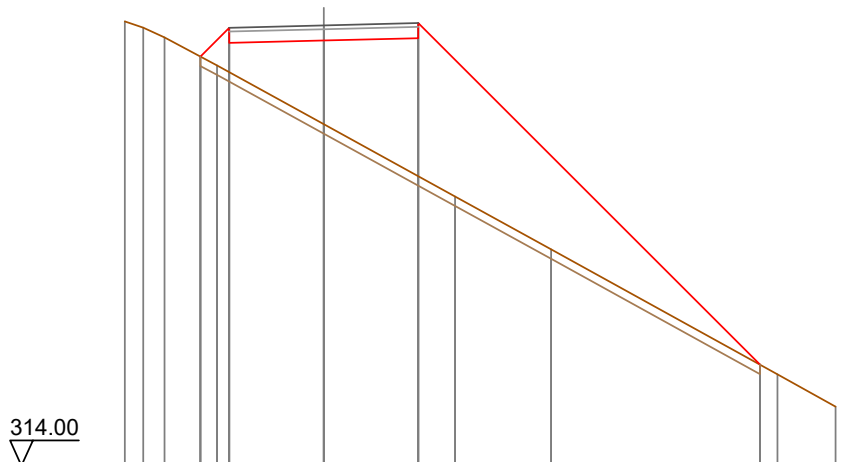

Quote Terreno	-325.75	-325.59	-325.33	-324.59	-323.03	-321.12	-319.72	-316.42	-315.56
Quote Progetto				324.82	325.18	325.25	325.31		316.67
Parziali				0.76	2.50	2.50	9.04		
Progressiva		-3.26	-2.50		0.00	2.50		11.54	
Dislivelli		0.00	1.17		2.21	3.65		0.00	

Sezione: 196
 Progressiva: 1051.173
 Q. Progetto: 327.031

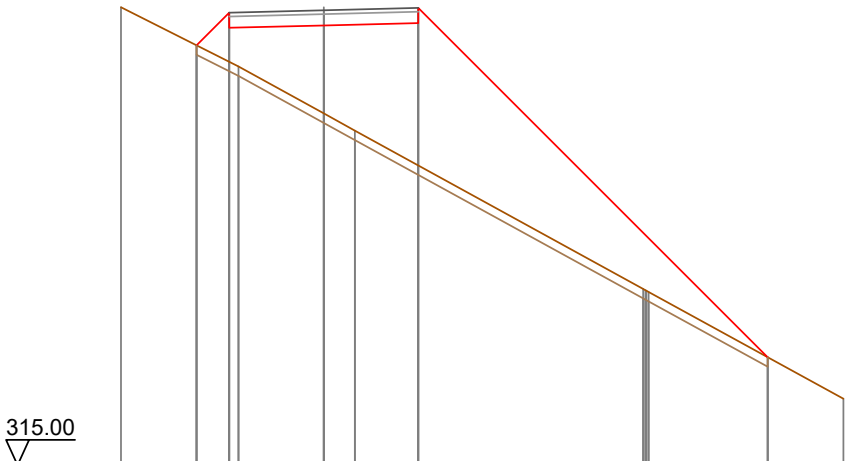

Quote Terreno	-327.11			-325.55	-324.31	-323.85		-319.66	-319.58	-316.76
Quote Progetto		326.11	326.57		326.63	326.69			317.85	
Parziali		0.86	2.50		2.50	9.24				
Progressiva		-3.36	-2.50		0.00	2.50		11.74		
Dislivelli		-0.00	1.30		2.33	3.76		0.00		

Sezione: 197
 Progressiva: 1054.310
 Q. Progetto: 327.728

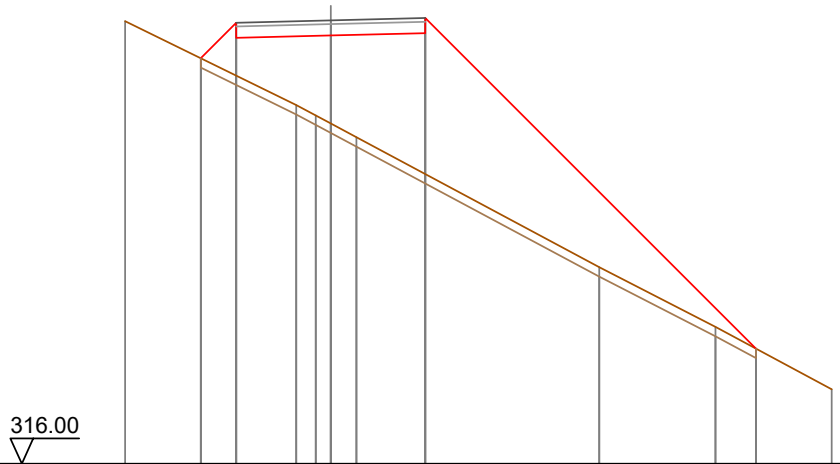

Quote Terreno		-327.71		-325.49	-325.21	-325.00	-324.64		-321.20	-319.62	-317.97
Quote Progetto			326.73	327.27		327.33		327.39			319.04
Parziali			0.94	2.50		2.50		8.75			
Progressiva			-3.44	-2.50		0.00		2.50			11.25
Dislivelli			-0.00	1.40		2.33		3.73			0.00

Sezione: 198
 Progressiva: 1057.448
 Q. Progetto: 328.425

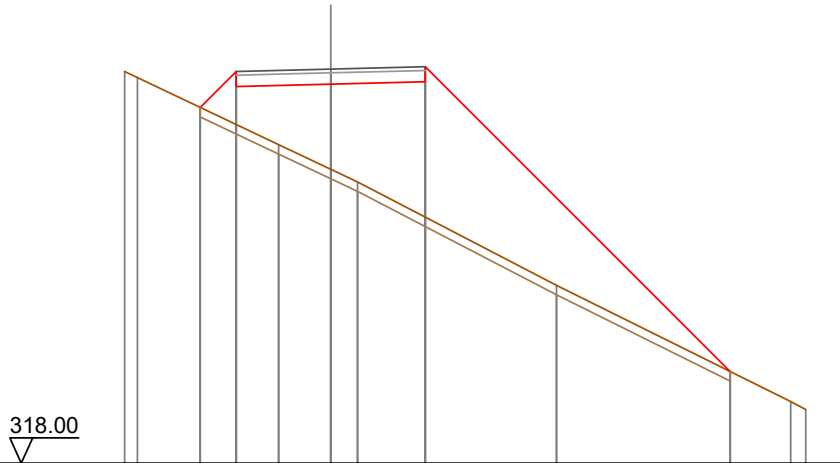

Quote Terreno		328.36	328.20		326.42	325.77	325.44		322.71		319.63	319.42
Quote Progetto				327.41	327.96		328.02	328.09			320.42	
Parziali				0.95	2.50		2.50	8.06				
Progressiva				-3.45	-2.50		0.00	2.50			10.56	
Dislivelli				-0.00	1.40		2.25	3.58			0.00	

Sezione: 199
 Progressiva: 1060.000
 Q. Progetto: 328.991

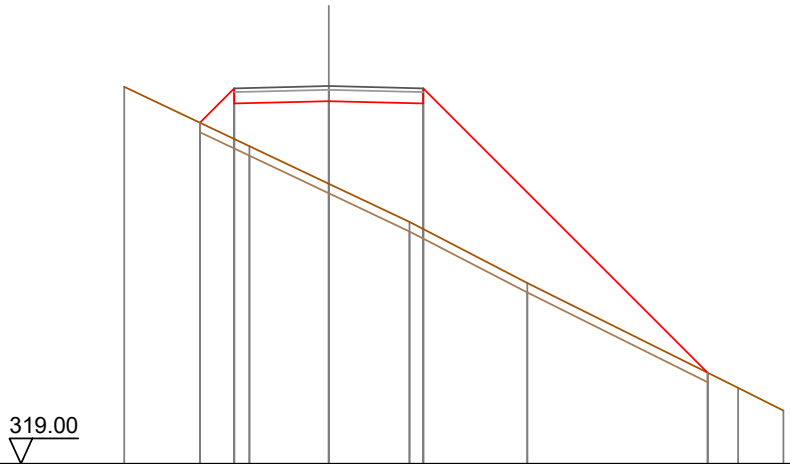

Quote Terreno	-328.97		327.40	326.41	325.40	323.78		321.01	320.41
Quote Progetto		328.02	328.53	328.59	328.53			321.41	
Parziali		0.91	2.50	2.50		7.52			
Progressiva		-3.41	-2.50	0.00	2.50			10.02	
Dislivelli		0.00	1.34	2.19	3.32			0.00	

Sezione: 200
 Progressiva: 1080.000
 Q. Progetto: 333.432

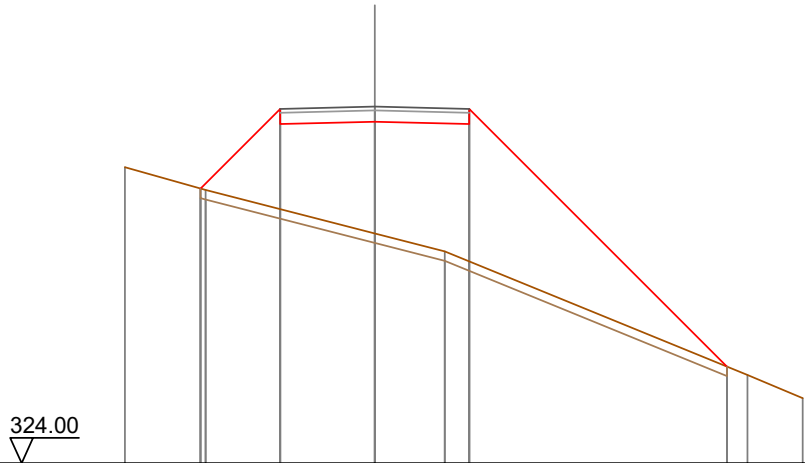

Quote Terreno	-331.83		331.23		330.08	329.60		326.33	325.72
Quote Progetto		331.26	332.97	333.03	332.97			326.55	
Parziali		2.11	2.50	2.50		6.82			
Progressiva		-4.61	-2.50	0.00	2.50			9.32	
Dislivelli		0.00	2.65	2.96	3.63			-0.00	

Sezione: 201
 Progressiva: 1100.000
 Q. Progetto: 337.873

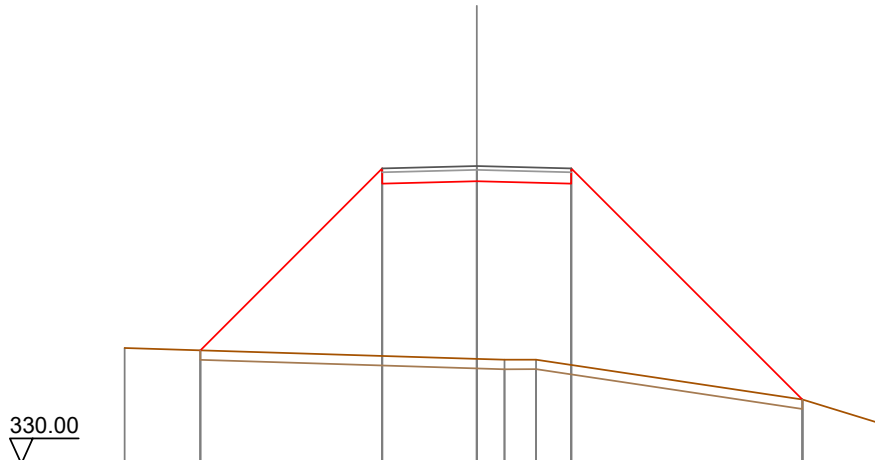

Quote Terreno		333.06			332.77	332.75	332.75		331.70	331.08
Quote Progetto		333.00		337.41	337.47		337.41		331.70	
Parziali			4.81		2.50	2.50		6.11		
Progressiva		-7.31		-2.50	0.00		2.50		8.61	
Dislivelli		0.00		4.96	4.70		4.80		0.00	

Sezione: 202
 Progressiva: 1120.000
 Q. Progetto: 342.314

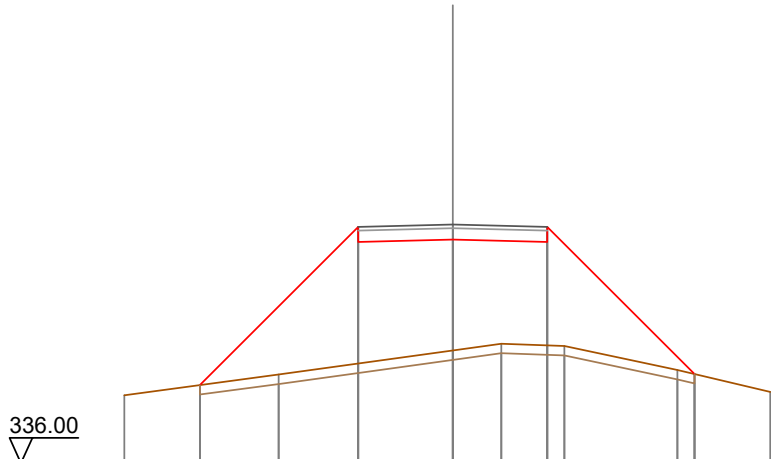

Quote Terreno		337.80		338.34		338.98	339.16	339.10	338.46	337.88
Quote Progetto		338.07		341.85	341.91		341.85		338.36	
Parziali			4.19		2.50	2.50		3.89		
Progressiva		-6.69		-2.50	0.00		2.50		6.39	
Dislivelli		-0.00		3.62	2.93		2.73		0.00	

Sezione: 203
 Progressiva: 1140.000
 Q. Progetto: 346.755

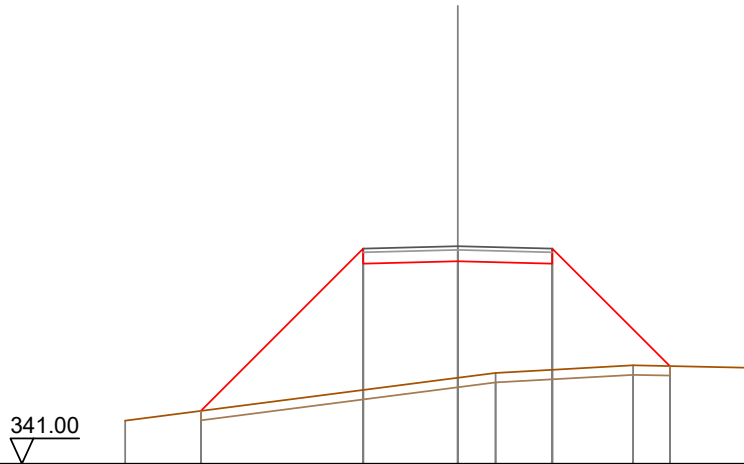

Quote Terreno		-342.14			343.27	-343.40		-343.60		-343.54	
Quote Progetto			342.40		346.29		346.35		346.29		343.58
Parziali				4.29		2.50		2.50		3.11	
Progressiva			-6.79		-2.50		0.00		2.50		5.61
Dislivelli			0.00		3.74		3.08		2.81		0.00

Sezione: 204
 Progressiva: 1146.854
 Q. Progetto: 348.277

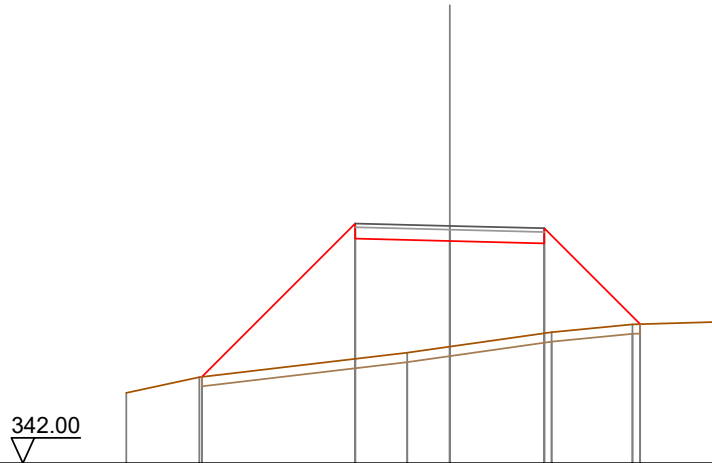

Quote Terreno		-343.86				-344.92		-345.08		-345.46		-345.67		-345.74
Quote Progetto				344.28		347.94		347.88		347.81		345.68		
Parziali					4.06		2.50		2.50		2.54			
Progressiva				-6.56		-2.50		0.00		2.50		5.04		
Dislivelli				0.00		3.58		2.79		2.38		0.00		

Sezione: 205
 Progressiva: 1150.000
 Q. Progetto: 348.975

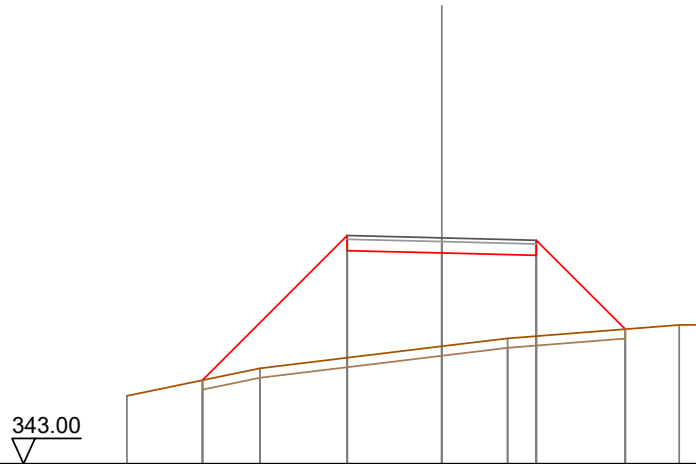

Quote Terreno	-344.80	-345.53	-346.11	-346.32	-346.67	-346.68
Quote Progetto	345.21	348.64	348.58	348.51	346.56	
Parziali		3.83	2.50	2.50	2.35	
Progressiva	-6.33	-2.50	0.00	2.50	4.85	
Dislivelli	0.00	3.23	2.47	2.14	0.00	

Sezione: 206
 Progressiva: 1153.185
 Q. Progetto: 349.682

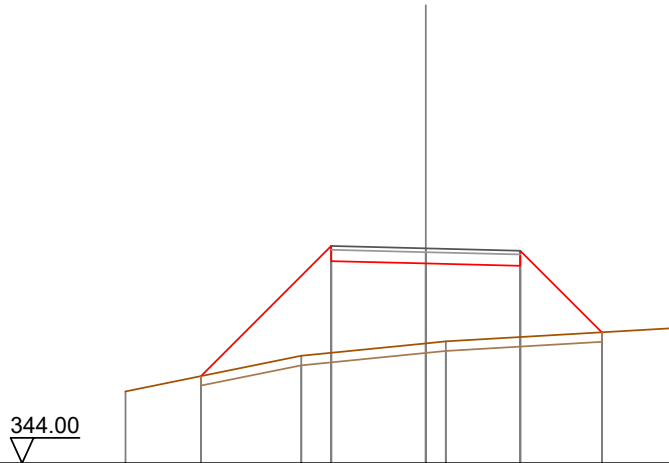

Quote Terreno	-345.90	-346.84	-347.17	-347.22	-347.58	
Quote Progetto	346.30	349.34	349.28	349.22	347.46	
Parziali		3.44	2.50	2.50	2.16	
Progressiva	-5.94	-2.50	0.00	2.50	4.66	
Dislivelli	0.00	2.83	2.11	1.88	0.00	

Sezione: 207
 Progressiva: 1159.515
 Q. Progetto: 351.088

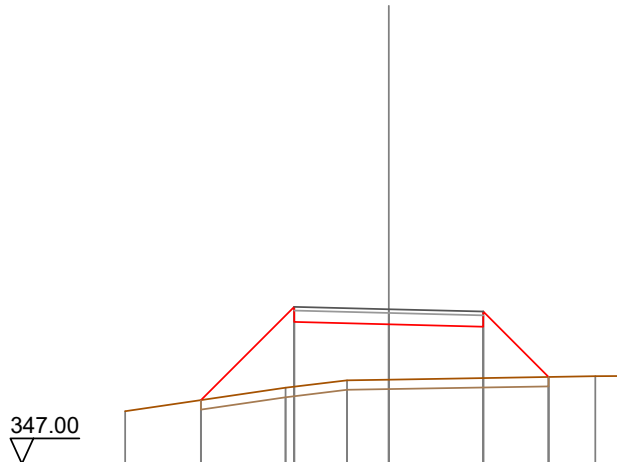

Quote Terreno		-348.39		349.01	-349.21	349.22				-349.32	-349.32
Quote Progetto			348.68	350.75		350.69		350.63	349.30		
Parziali				2.47	2.50	2.50		1.73			
Progressiva			-4.97	-2.50	0.00		2.50	4.23			
Dislivelli			0.00	2.11	1.46		1.36	0.00			

Sezione: 208
 Progressiva: 1160.000
 Q. Progetto: 351.196

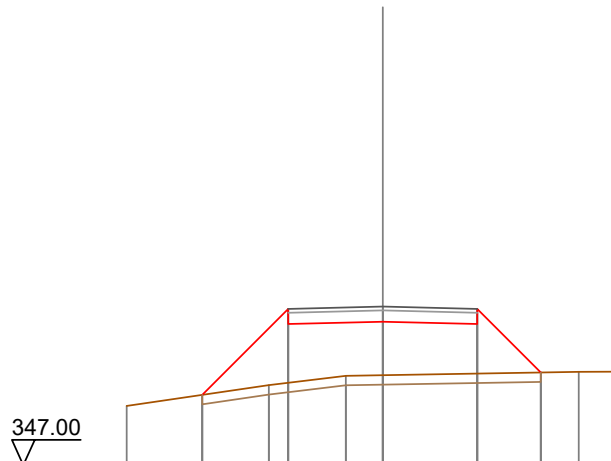

Quote Terreno		-348.57		349.12	-349.36	349.38				-349.47	-349.47
Quote Progetto			348.86	350.73		350.80		350.73	349.45		
Parziali				2.27	2.50	2.50		1.68			
Progressiva			-4.77	-2.50	0.00		2.50	4.18			
Dislivelli			0.00	1.95	1.41		1.31	0.00			

Sezione: 209
 Progressiva: 1169.916
 Q. Progetto: 353.397

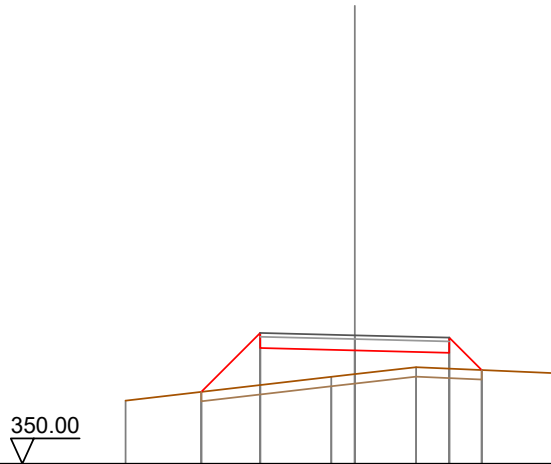

Quote Terreno	-351.67		-352.30	-352.37	-352.55		-352.39
Quote Progetto		351.90	353.06	353.00	352.93	352.48	
Parziali		1.56	2.50	2.50	0.86		
Progressiva		-4.06	-2.50	0.00	2.50	3.36	
Dislivelli		0.00	1.38	0.63	0.42	0.00	

Sezione: 210
 Progressiva: 1178.128
 Q. Progetto: 355.221

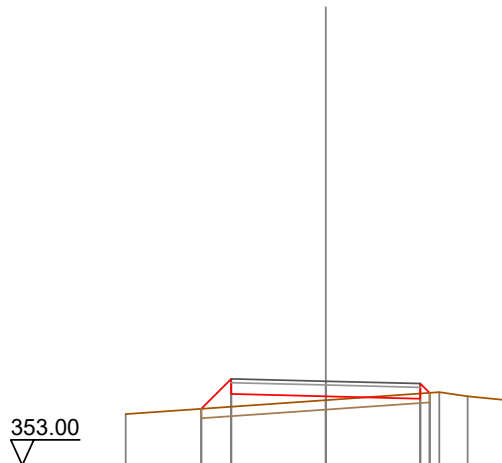

Quote Terreno	-354.35		-354.72		-354.93	-354.82	-354.72
Quote Progetto		354.49	354.88	354.82	354.76	354.91	
Parziali		0.79	2.50	2.50			
Progressiva		-3.29	-2.50	0.00	2.50	2.75	
Dislivelli		0.00	0.74	0.10	-0.14	0.00	

Sezione: 211
 Progressiva: 1180.000
 Q. Progetto: 355.636

353.00

Quote Terreno	355.04	355.05		355.34	355.52	355.29
Quote Progetto		355.16	355.30	355.24	355.17	355.49
Parziali		0.54	2.50	2.50		
Progressiva		-3.04	-2.50	0.00	2.50	2.59
Dislivelli		-0.00	0.51	-0.10	-0.31	-0.00

Sezione: 212
 Progressiva: 1186.340
 Q. Progetto: 357.044

355.00

Quote Terreno	357.36		357.45	357.48	357.50	357.11
Quote Progetto		357.40	356.64	357.48	356.58	357.50
Parziali		0.28	2.50	2.50	0.52	
Progressiva		-2.79	-2.50	0.00	2.50	3.02
Dislivelli		-0.00	-0.30	-0.81	-0.91	0.00

Sezione: 213
 Progressiva: 1200.000
 Q. Progetto: 360.077

358.00

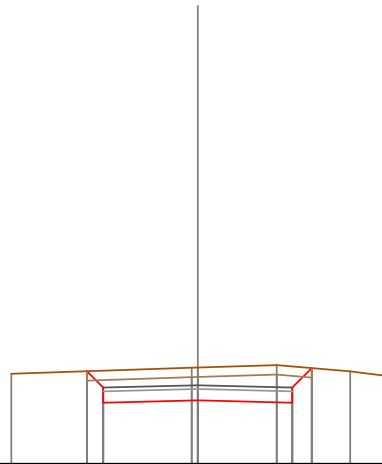

Quote Terreno	-360.38			-360.54	-360.55		-360.61		-360.44	-360.32
Quote Progetto		360.45	359.61	359.68		359.61	360.53			
Parziali		0.43	2.50	2.50	0.51					
Progressiva		-2.93	-2.50	0.00	2.50	3.01				
Dislivelli		-0.00	-0.45	-0.87	-0.96	0.00				

Sezione: 214
 Progressiva: 1217.541
 Q. Progetto: 363.972

362.00



Quote Terreno	-364.71	364.73		364.80	364.82	364.78			-364.31
Quote Progetto		364.74	363.63	363.57	364.80	363.51	364.55		
Parziali		0.71	2.50	2.50	0.64				
Progressiva		-3.21	-2.50	0.00	2.50	3.14			
Dislivelli		0.00	-0.72	-1.23	-1.12	0.00			

Sezione: 215
 Progressiva: 1220.000
 Q. Progetto: 364.518

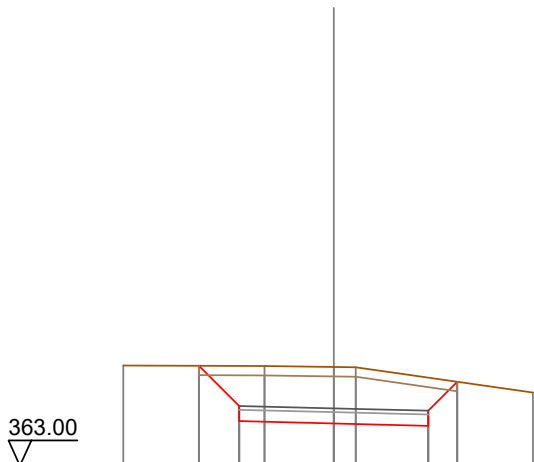

Quote Terreno		365.65		365.64		365.61	365.61		364.94
Quote Progetto			365.65	364.18		364.12		364.06	365.22
Parziali			1.07	2.50		2.50		0.77	
Progressiva			-3.57	-2.50		0.00		2.50	3.27
Dislivelli			0.00	-1.06		-1.50		-1.28	0.00

Sezione: 216
 Progressiva: 1220.738
 Q. Progetto: 364.682

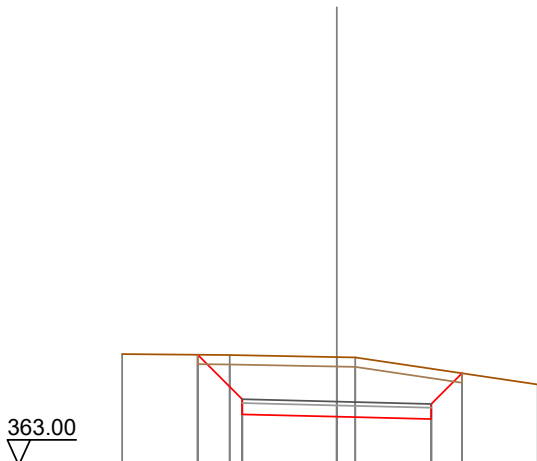

Quote Terreno		365.94		365.91		365.86	365.85		365.14
Quote Progetto			365.92	364.34		364.28		364.22	365.43
Parziali			1.18	2.50		2.50		0.81	
Progressiva			-3.68	-2.50		0.00		2.50	3.31
Dislivelli			-0.00	-1.16		-1.58		-1.33	-0.00

Sezione: 217
 Progressiva: 1223.935
 Q. Progetto: 365.392

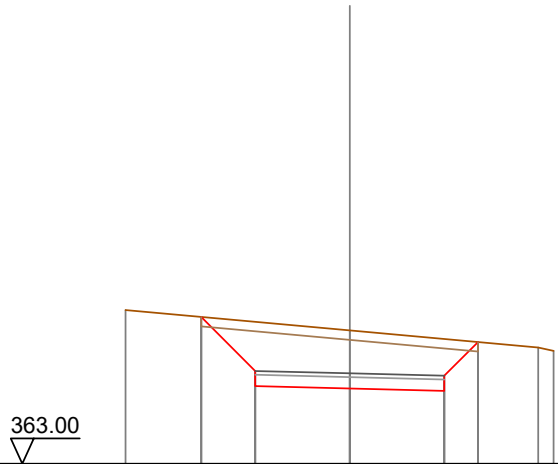

Quote Terreno		367.06		366.53		366.08	365.98
Quote Progetto			366.88	365.05	364.99	364.93	366.22
Parziali			1.43	2.50	2.50	0.89	
Progressiva			-3.93	-2.50	0.00	2.50	3.39
Dislivelli			0.00	-1.30	-1.53	-1.37	0.00

Sezione: 218
 Progressiva: 1230.741
 Q. Progetto: 366.903

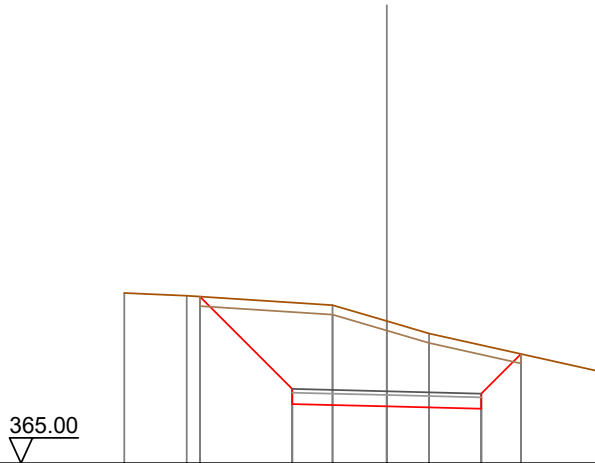

Quote Terreno		369.50	369.43	369.18	368.76	368.43	367.44
Quote Progetto			369.41	366.57	366.50	366.44	367.89
Parziali			2.44	2.50	2.50	1.05	
Progressiva			-4.94	-2.50	0.00	2.50	3.55
Dislivelli			-0.00	-2.28	-2.26	-1.68	-0.00

Sezione: 219
 Progressiva: 1233.123
 Q. Progetto: 367.432

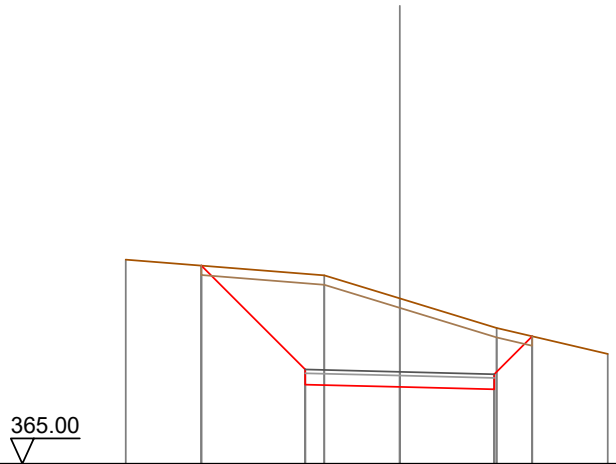

Quote Terreno		370.40		369.99	369.37	368.59		367.91
Quote Progetto			370.24	367.09	367.03	366.97	368.37	
Parziali			2.75	2.50	2.50	1.00		
Progressiva			-5.25	-2.50	0.00	2.50	3.50	
Dislivelli			0.00	-2.53	-2.34	-1.64	0.00	

Sezione: 220
 Progressiva: 1235.505
 Q. Progetto: 367.961

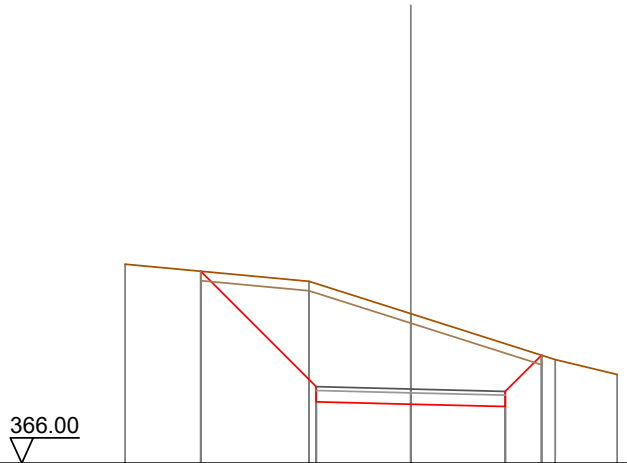

Quote Terreno		371.26		370.81	369.95		368.74	368.34
Quote Progetto			371.08	367.62	367.56	367.50	368.86	
Parziali			3.05	2.50	2.50	0.96		
Progressiva			-5.55	-2.50	0.00	2.50	3.46	
Dislivelli			0.00	-2.73	-2.39	-1.66	0.00	

Sezione: 221
 Progressiva: 1240.000
 Q. Progetto: 368.959

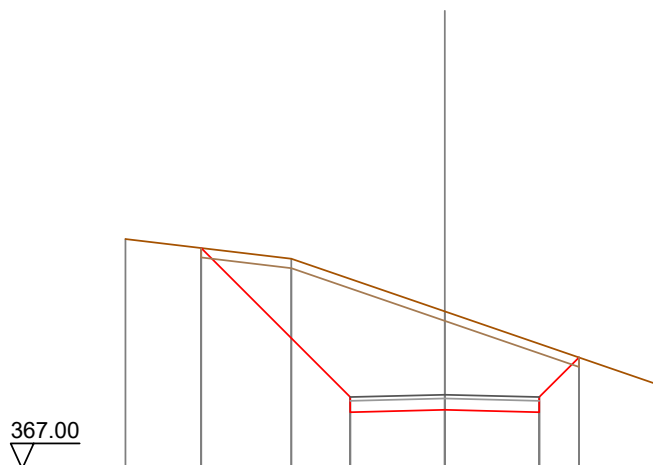

Quote Terreno		373.08	372.55	371.16		369.26	
Quote Progetto			372.84	368.50	368.56	368.50	369.94
Parziali			3.94	2.50	2.50	1.05	
Progressiva			-6.44	-2.50	0.00	2.50	3.55
Dislivelli			0.00	-3.12	-2.60	-1.81	0.00

Sezione: 222
 Progressiva: 1248.319
 Q. Progetto: 370.806

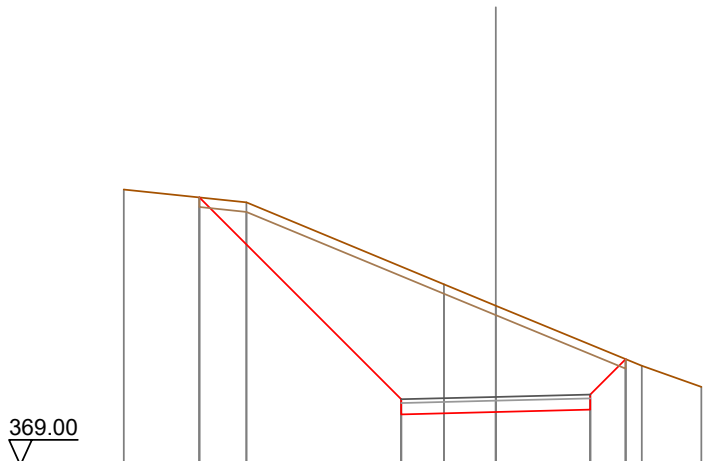

Quote Terreno		376.29	375.95	373.78	373.22	371.63	371.07
Quote Progetto			376.08	370.34	370.41	370.47	371.80
Parziali			5.34	2.50	2.50	0.94	
Progressiva			-7.84	-2.50	0.00	2.50	3.44
Dislivelli			0.00	-3.51	-2.81	-1.72	0.00

Sezione: 223
 Progressiva: 1250.000
 Q. Progetto: 371.179

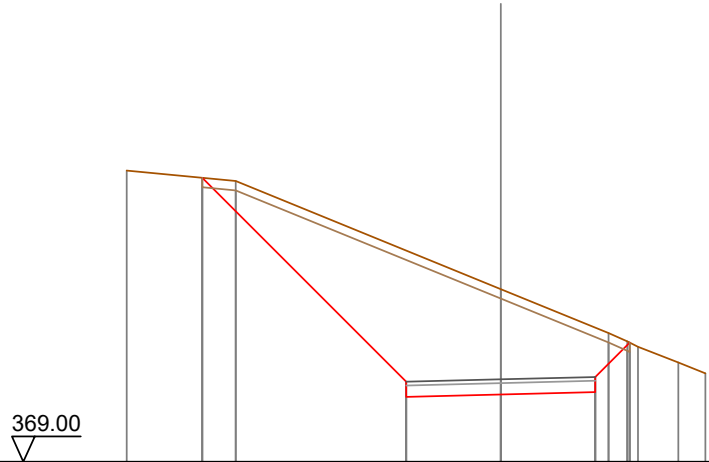

Quote Terreno	-376.70	-376.43		370.72	370.78	373.57	372.40	372.04	-371.62	-371.34
Quote Progetto		376.51		370.72	370.78		370.84	372.15		
Parziali			5.39		2.50	2.50	0.91			
Progressiva		-7.89		-2.50	0.00		2.50	3.41		
Dislivelli		-0.00		-3.47	-2.79		-1.71	-0.00		

Sezione: 224
 Progressiva: 1255.236
 Q. Progetto: 372.342

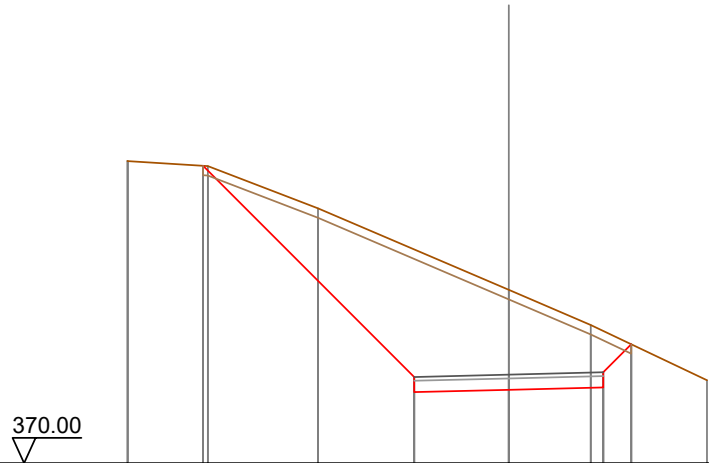

Quote Terreno	-377.99	-377.86	-376.74		374.58	373.66		-372.19
Quote Progetto		377.87	377.86	371.88	371.94	372.00	373.15	
Parziali			5.59		2.50	2.50	0.74	
Progressiva		-8.09		-2.50	0.00		2.50	3.24
Dislivelli		-0.00		-3.37	-2.64		-1.49	-0.00

Sezione: 225
 Progressiva: 1260.000
 Q. Progetto: 373.400

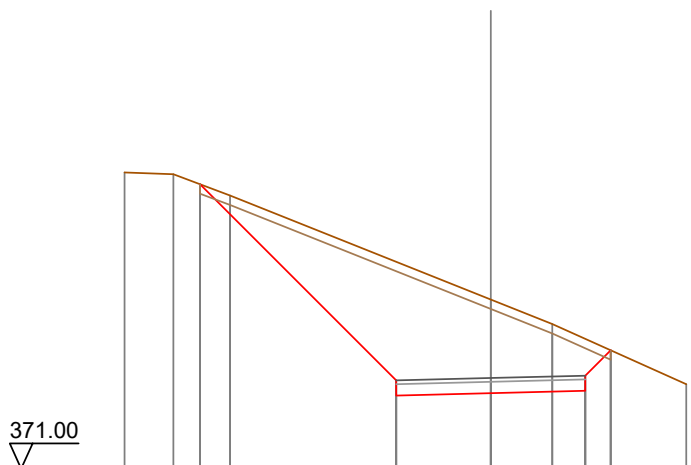

Quote Terreno		-378.84	-378.79	-378.23		-375.48	-374.83		-373.24
Quote Progetto			378.52		372.94	373.00		373.06	374.13
Parziali				5.19		2.50		2.50	0.67
Progressiva			-7.69		-2.50	0.00		2.50	3.17
Dislivelli			0.00		-3.14	-2.48		-1.37	-0.00

Sezione: 226
 Progressiva: 1262.152
 Q. Progetto: 373.878

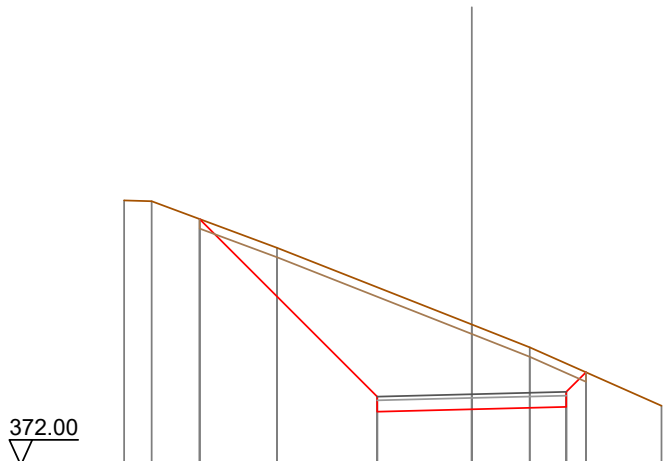

Quote Terreno		-379.00	-378.98	-377.75		-375.72	-375.12		-373.57
Quote Progetto			378.51		373.42	373.48		373.54	374.46
Parziali				4.69		2.50		2.50	0.52
Progressiva			-7.19		-2.50	0.00		2.50	3.02
Dislivelli			0.00		-2.89	-2.24		-1.15	0.00

Sezione: 227
 Progressiva: 1280.000
 Q. Progetto: 377.840

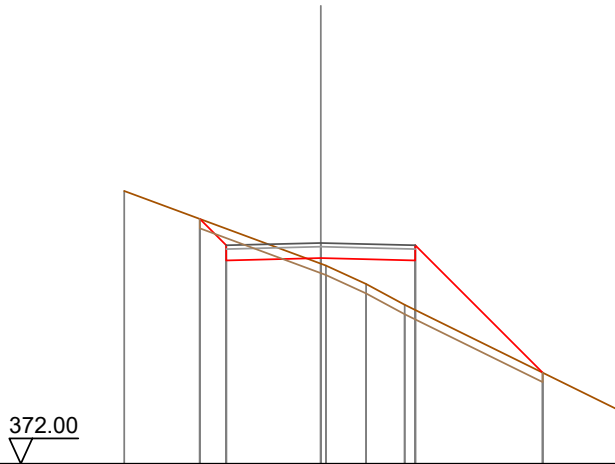

Quote Terreno		-379.22			377.29	377.24	-376.75	376.20		-373.42
Quote Progetto			378.48	377.38	377.44		377.38		374.41	
Parziali			0.70	2.50		2.50		3.37		
Progressiva			-3.20	-2.50	0.00		2.50		5.87	
Dislivelli			0.00	-0.44		0.15		1.31		0.00

Sezione: 228
 Progressiva: 1297.102
 Q. Progetto: 381.638

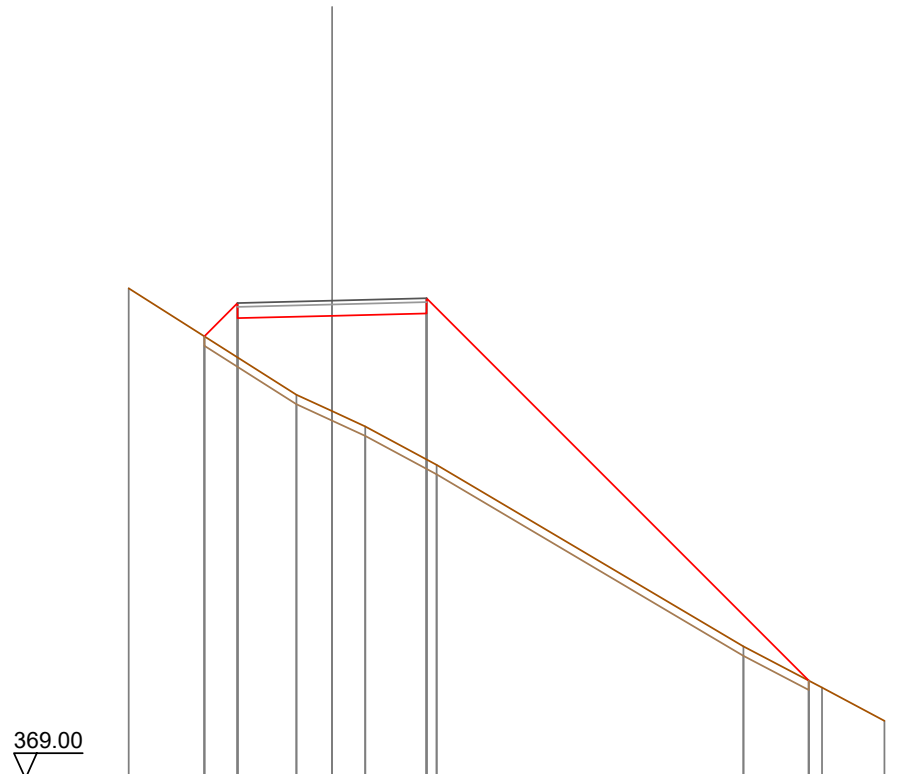

Quote Terreno		381.97		379.15	378.72	378.31	377.30			372.50	371.41	370.53
Quote Progetto			380.70	381.18	381.24		381.30				371.59	
Parziali			0.88	2.50		2.50		10.11				
Progressiva			-3.38	-2.50	0.00		2.50				12.61	
Dislivelli			-0.00	1.44	2.52		3.86				0.00	

Sezione: 229
 Progressiva: 1297.862
 Q. Progetto: 381.807

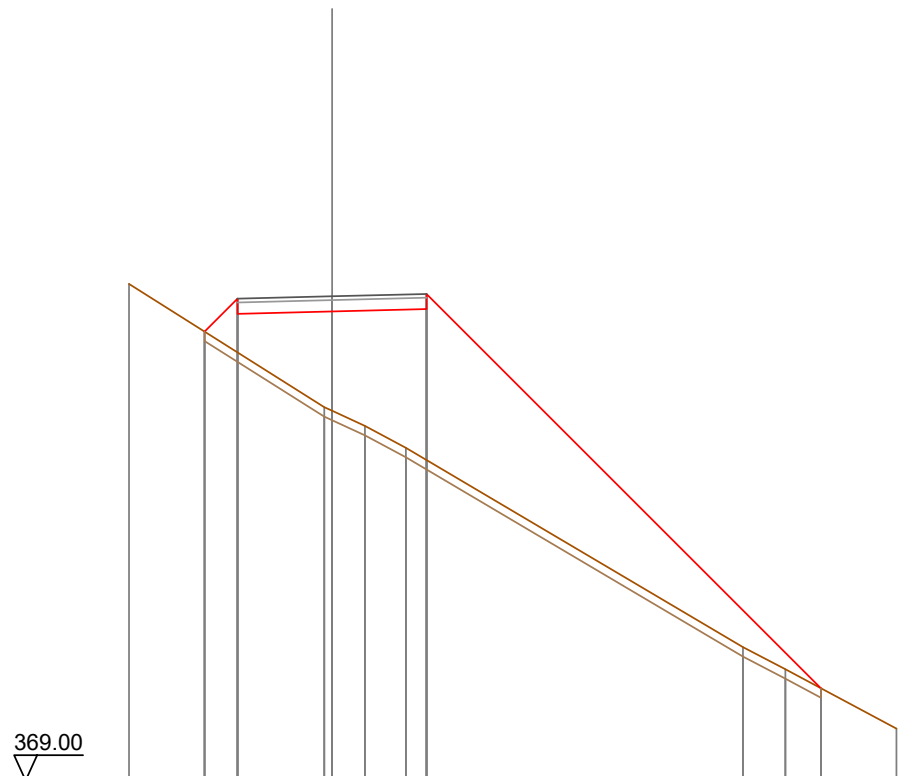

Quote Terreno		-382.13			378.88	378.78	-378.38	-377.80			372.53	-371.94		-370.37
Quote Progetto			380.87	381.34	381.41			381.47				371.44		
Parziali			0.87	2.50		2.50		10.43						
Progressiva			-3.37	-2.50	0.00		2.50					12.93		
Dislivelli			0.00	1.42	2.63		3.99					0.00		

Sezione: 230
 Progressiva: 1298.623
 Q. Progetto: 381.976

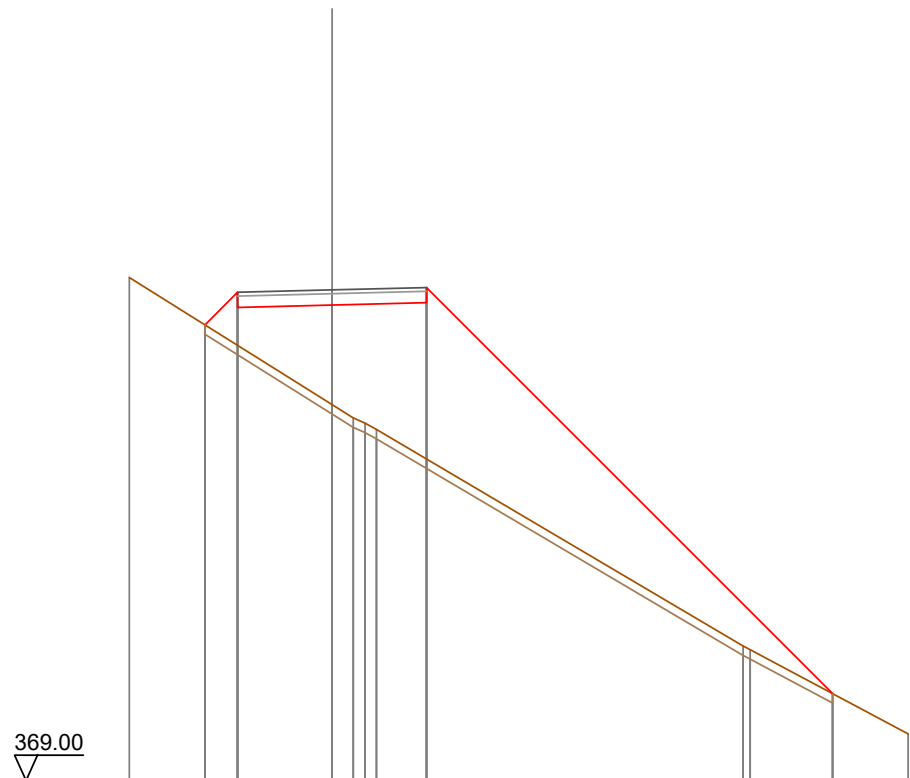

Quote Terreno		382.30		378.94	378.45	378.29		372.56	372.46		370.23
Quote Progetto			381.05	381.51	381.58		381.64			371.30	
Parziali			0.86	2.50	2.50		10.74				
Progressiva			-3.36	-2.50	0.00	2.50				13.24	
Dislivelli			0.00	1.40	2.63	4.13				0.00	

Sezione: 231
 Progressiva: 1300.000
 Q. Progetto: 382.281

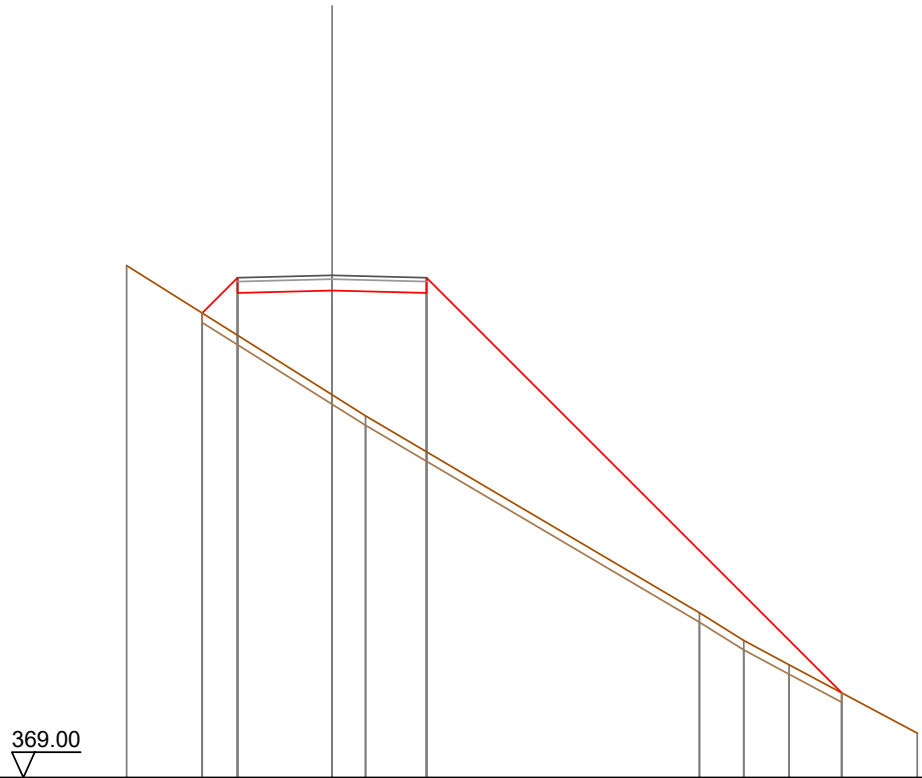

Quote Terreno		-382.54			379.12	-378.57			-373.36	-372.63	-371.98		-370.17
Quote Progetto			-381.28	-381.82	-381.88		-381.82					-371.24	
Parziali			0.93	2.50		2.50		10.98					
Progressiva			-3.43	-2.50	0.00		2.50					13.48	
Dislivelli			0.00	1.52	2.76		4.20					-0.00	

Sezione: 233
 Progressiva: 1340.000
 Q. Progetto: 389.406

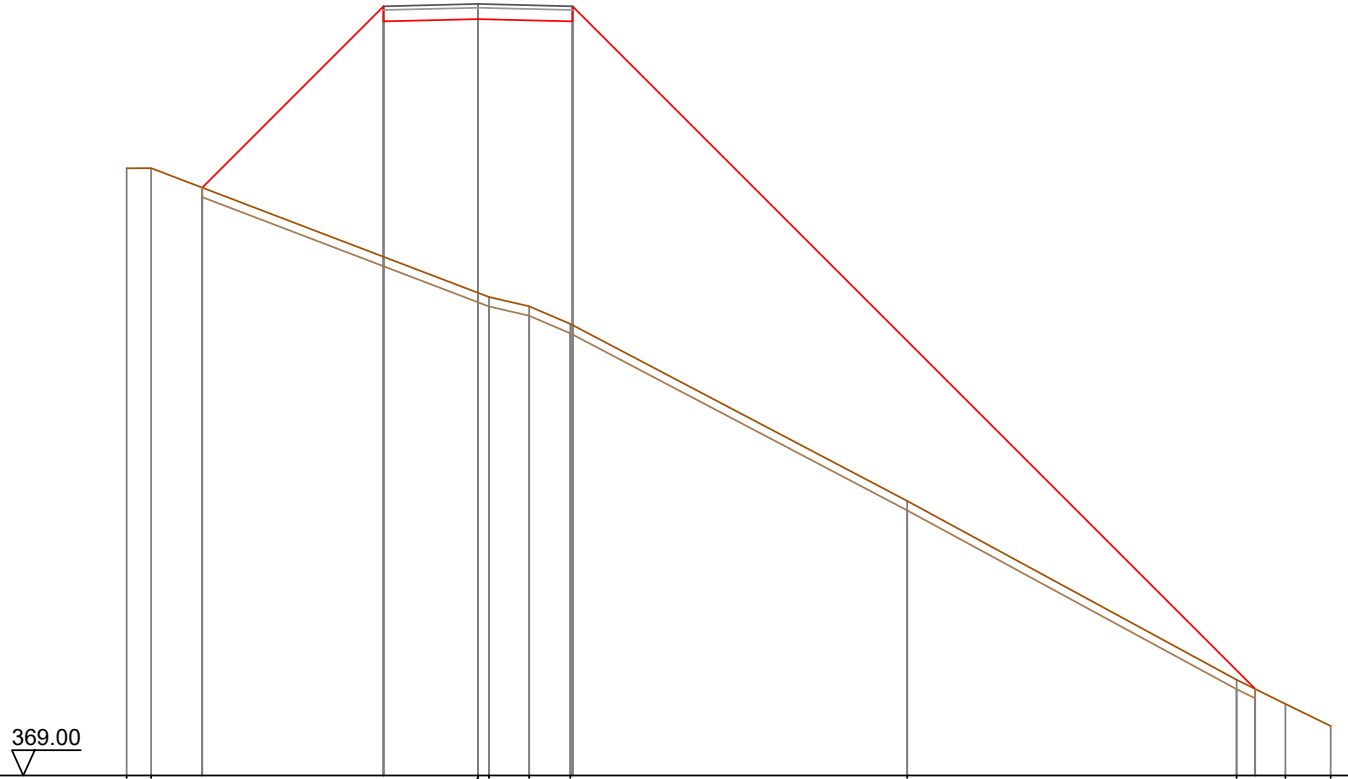

Quote Terreno		-385.06	-385.06		-381.77	-381.66	-381.41	-380.94		-376.26		-371.53	-370.90	-370.31
Quote Progetto				384.55		388.94	389.01	389.41	388.94				371.29	
Parziali					4.80	2.50	2.50			18.05				
Progressiva			-7.30			-2.50	0.00	2.50					20.55	
Dislivelli			0.00		6.62	7.24	8.03					0.00		

Sezione: 234
 Progressiva: 1353.418
 Q. Progetto: 391.053

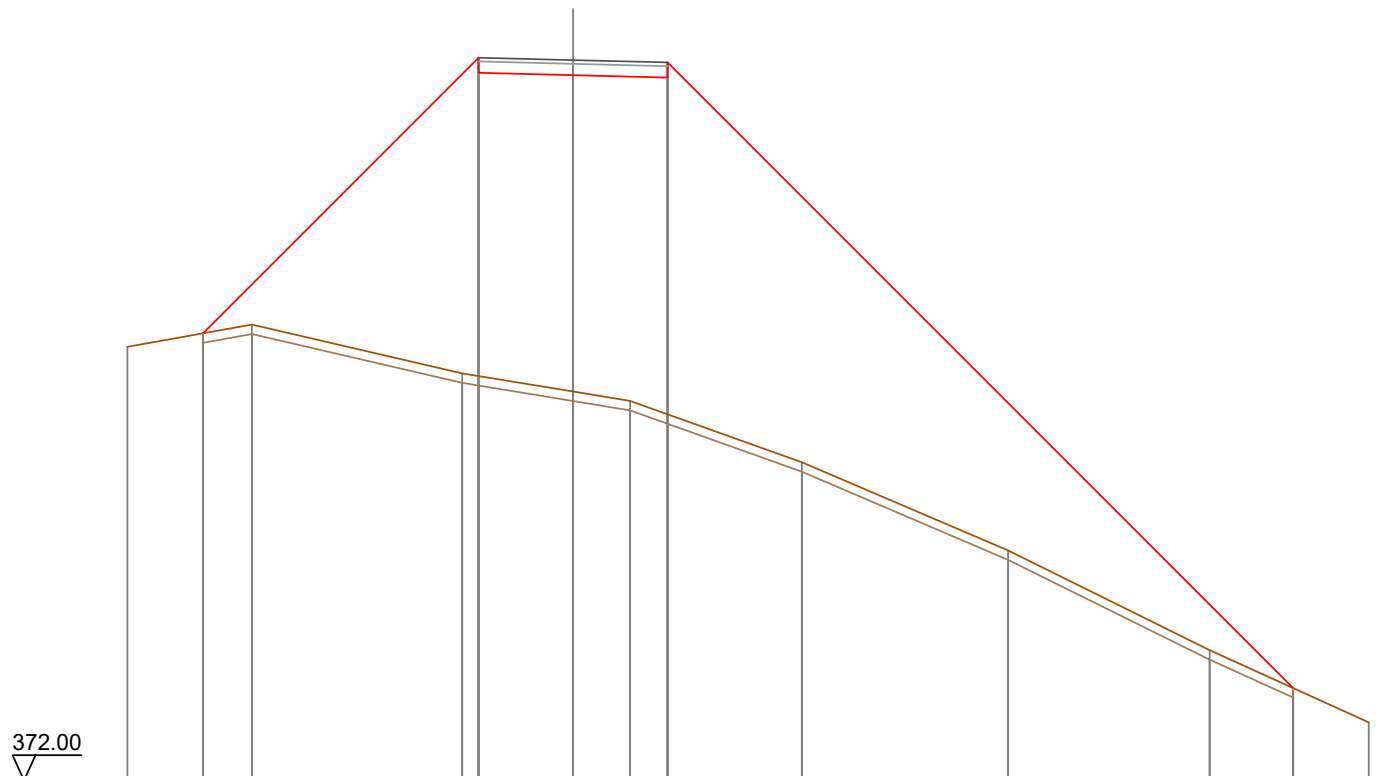

372.00

Quote Terreno	-383.47	-384.06	-382.77	-382.29	-382.04	-380.42	-378.08	-375.45	-373.54
Quote Progetto		383.83	390.72	390.65	390.59				374.44
Parziali			7.29	2.50	2.50		16.55		
Progressiva		-9.79	-2.50	0.00	2.50				19.05
Dislivelli		0.00	8.42	8.37	8.90				-0.00

Sezione: 236
 Progressiva: 1360.000
 Q. Progetto: 391.727

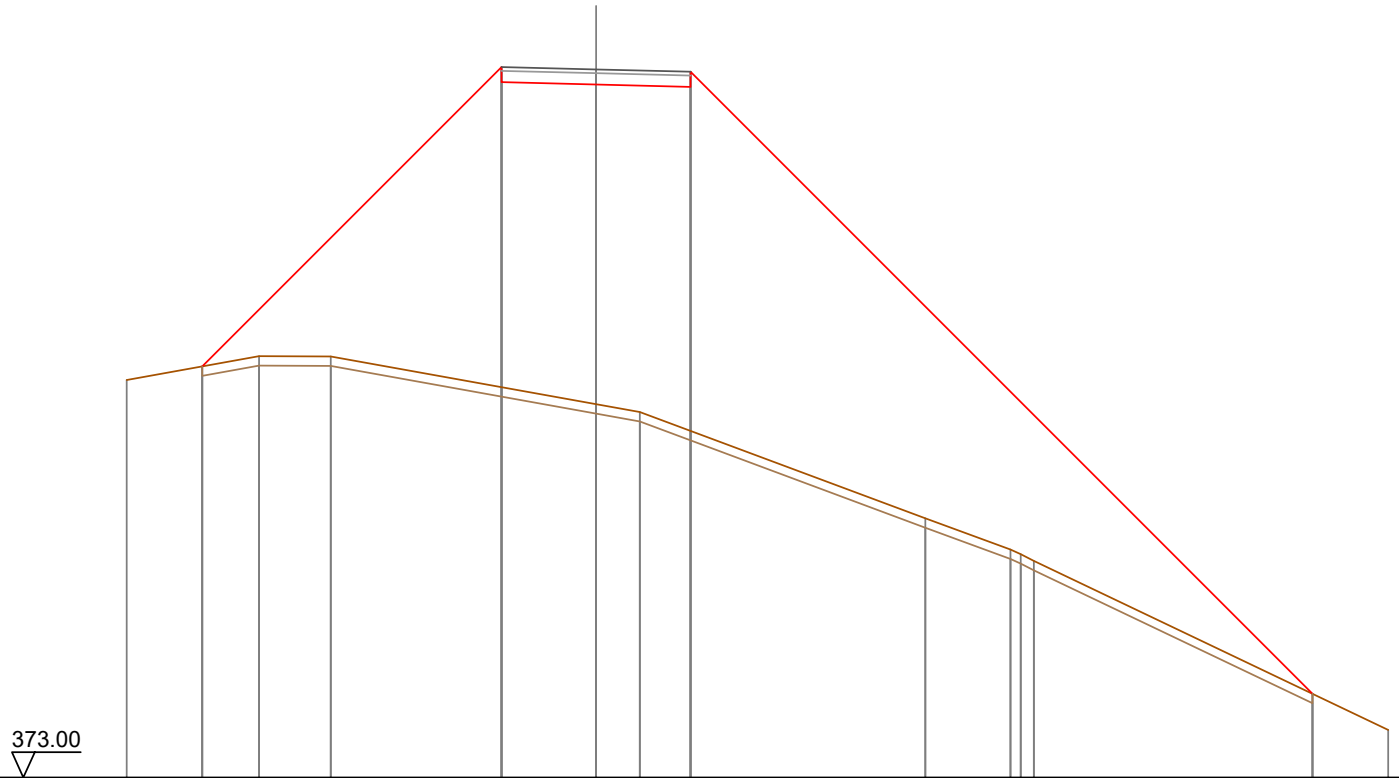

Quote Terreno	383.51	383.87	384.14	384.14	391.39	382.87	382.67	391.26	379.86	379.03	378.91	378.73	375.21	374.26
Quote Progetto		383.87			391.39	391.33	391.26						375.21	
Parziali			7.92		2.50	2.50				16.45				
Progressiva		-10.42			-2.50	0.00	2.50						18.95	
Dislivelli		0.00			8.47	8.45	9.10						0.00	

Sezione: 237
 Progressiva: 1364.422
 Q. Progetto: 392.130

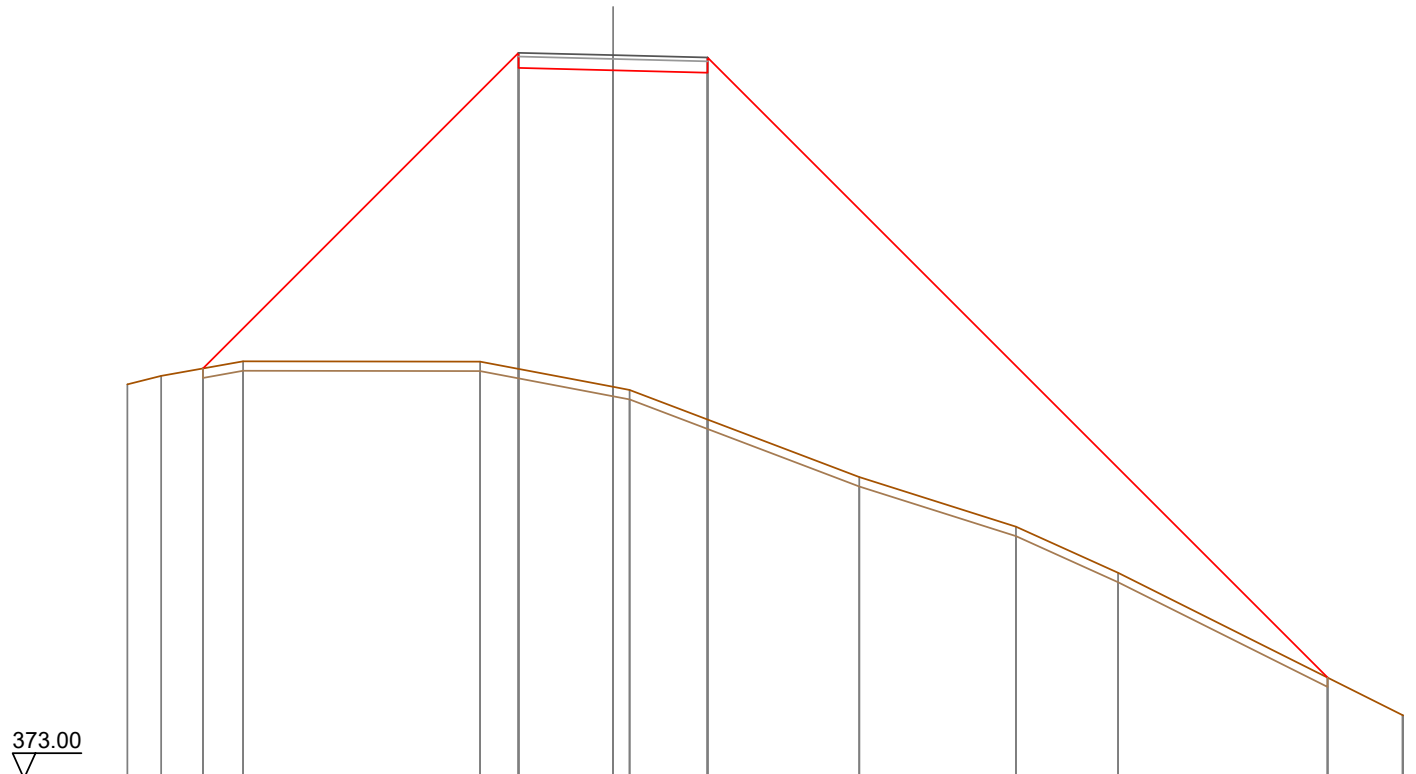

373.00

Quote Terreno		383.42	383.65	384.04		384.03	383.36	383.28		380.97	379.66	378.44		374.67
Quote Progetto			383.85			391.79	391.73	383.28	391.67					375.67
Parziali				8.35		2.50	2.50			16.40				
Progressiva			-10.85			-2.50	0.00	2.50						18.90
Dislivelli			0.00			8.36	8.37	9.17						0.00

Sezione: 238
 Progressiva: 1380.000
 Q. Progetto: 393.237

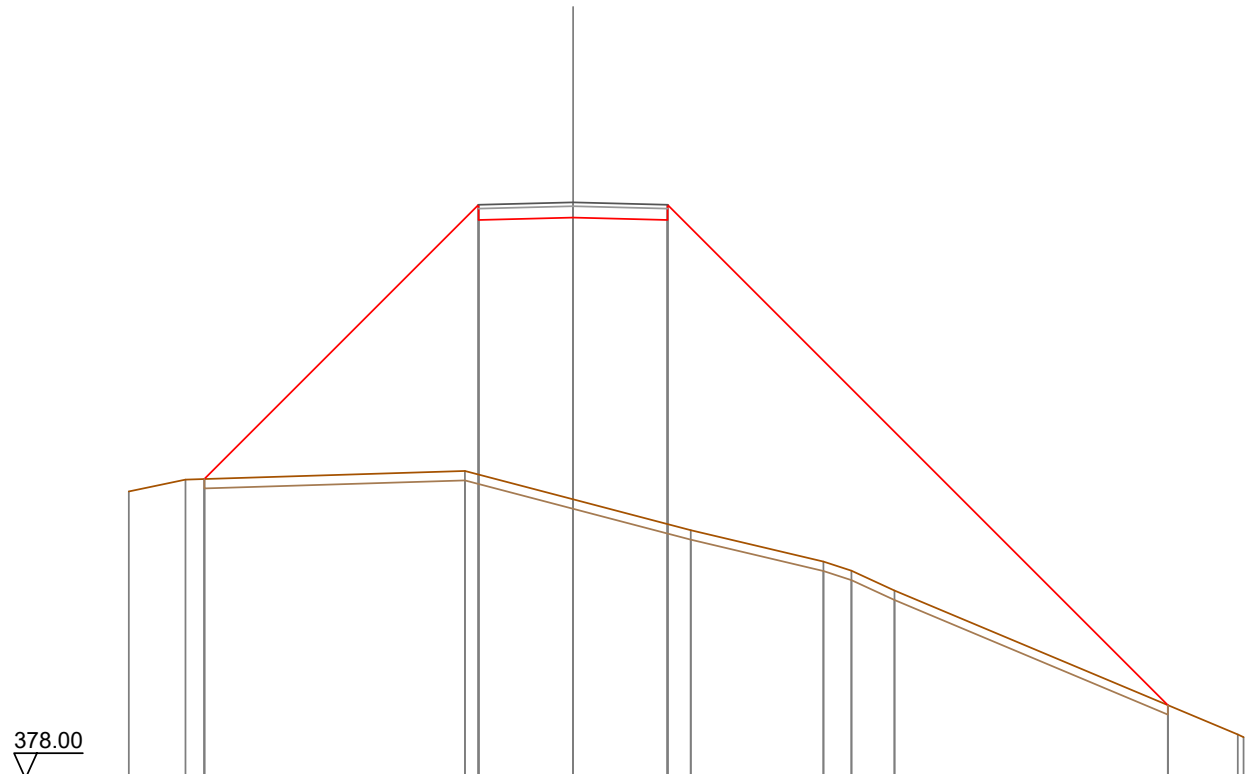

Quote Terreno		-385.59	-385.91	-386.13	-385.38	-384.57	-383.74	-383.50	-382.97		379.17	379.09
Quote Progetto			-385.92	-392.77	-392.84	-392.77					379.94	
Parziali				7.25	2.50	2.50			13.23			
Progressiva			-9.75	-2.50	0.00	2.50					15.73	
Dislivelli			0.00	7.13	7.45	8.05					0.00	

Sezione: 239
 Progressiva: 1392.758
 Q. Progetto: 393.779

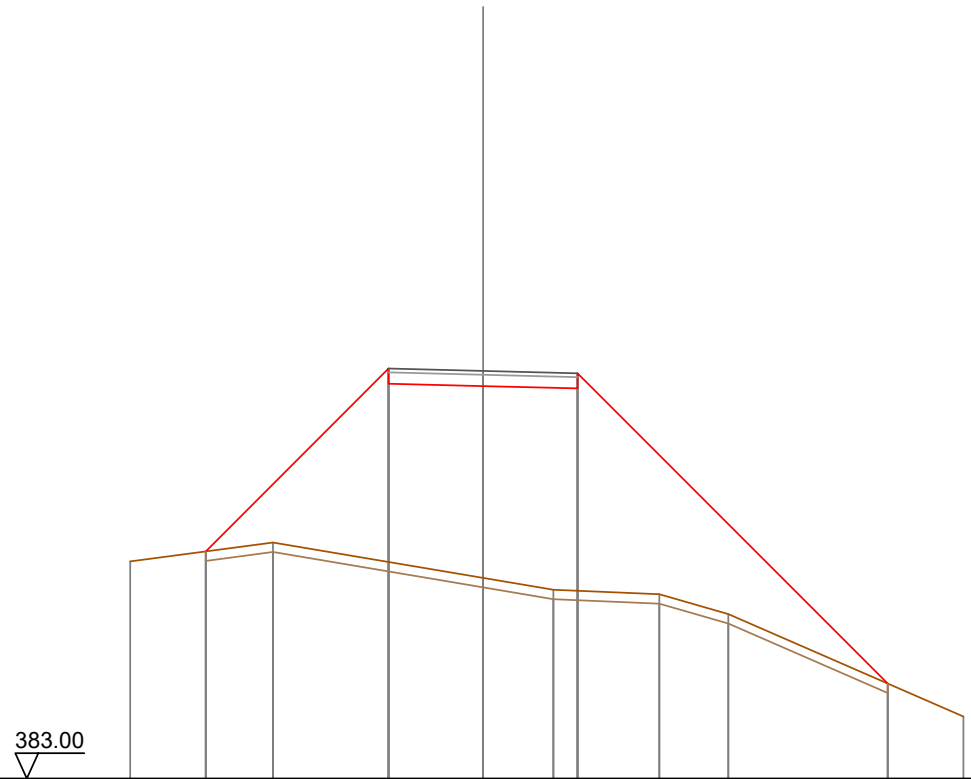

Quote Terreno	-388.74	-389.24	-388.31	-387.99	-387.88	-387.35	-384.64
Quote Progetto	-389.01	-393.44	-393.38	-393.32	-385.51		
Parziali		4.84	2.50	2.50	8.20		
Progressiva	-7.34	-2.50	0.00	2.50	10.70		
Dislivelli	0.00	5.12	5.07	5.35	0.00		

Sezione: 240
 Progressiva: 1400.000
 Q. Progetto: 393.942

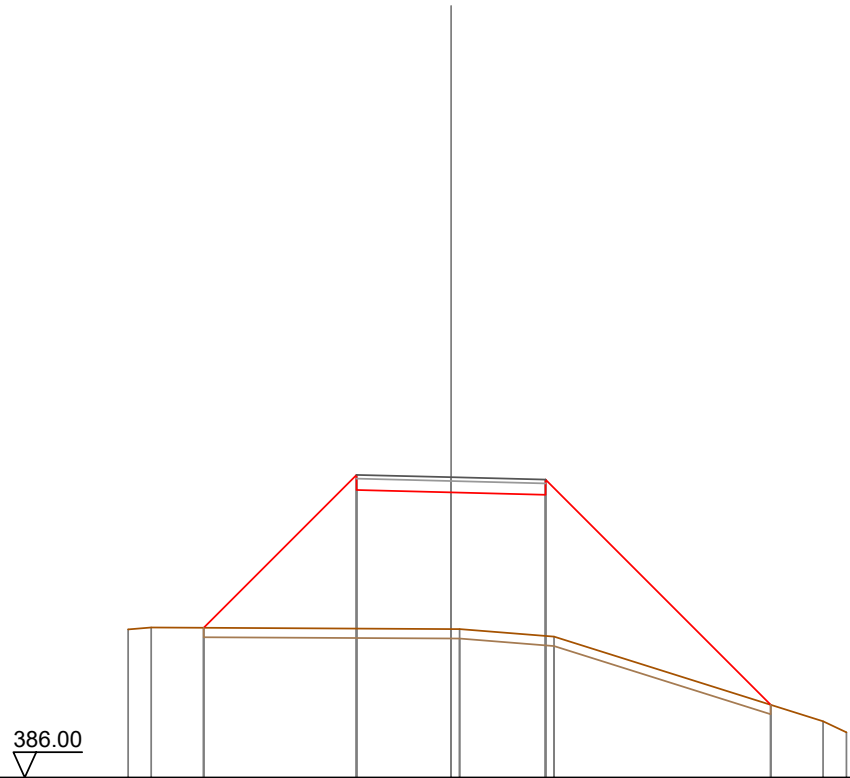

Quote Terreno		389.92	389.97		389.93	389.93	389.73		387.49	387.20
Quote Progetto			389.96		393.60	393.54	393.48		387.92	
Parziali				4.04		2.50	2.50		5.96	
Progressiva			-6.54		-2.50	0.00	2.50		8.46	
Dislivelli			0.00		4.06	3.62	3.73		-0.00	

SEZIONI TRASVERSALI
Profilo longitudinale tratto 3-4
Viabilità di impianto - Postazione aerogeneratore
VI02

Nota: Le canalette di deflusso delle acque meteoriche, non indicate nel presente elaborato, sono rappresentate graficamente nelle sezioni stradali tipo dell'elaborato "SR-VI-TC12_Piazzole aerogeneratori e strade di servizio - Particolari costruttivi", individuate planimetricamente nell'elaborato "SR-VI-TC13_Opere di regimazione acque superficiali - Planimetria generale" e quantificate nell'elaborato "SR-VI-RC6_Computo Metrico Estimativo opere civili".

DISEGNI DI RIFERIMENTO

TAVOLA	DESCRIZIONE
SR-VI-TC8.1	Piazzole e viabilità - Planimetria di progetto - Fase di cantiere
SR-VI-TC10	Profili longitudinali viabilità di impianto
SR-VI-TC12	Piazzole aerogeneratori e strade di servizio - Particolari costruttivi
SR-VI-TC13	Opere di regimazione acque superficiali - Planimetria generale

Sezione: 1
 Progressiva: 0.000
 Q. Progetto: 394.000

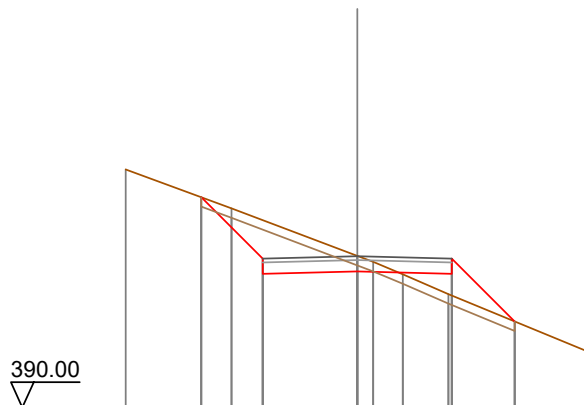

Quote Terreno		396.30		395.27		394.01	393.85	393.52	393.00		391.45
Quote Progetto			395.56		393.54		393.60		393.54	392.27	
Parziali				1.62		2.50		2.50		1.66	
Progressiva			-4.12		-2.50		0.00		2.50		4.16
Dislivelli			0.00		-1.02		-0.41		0.58		0.00

Sezione: 2
 Progressiva: 13.384
 Q. Progetto: 394.123

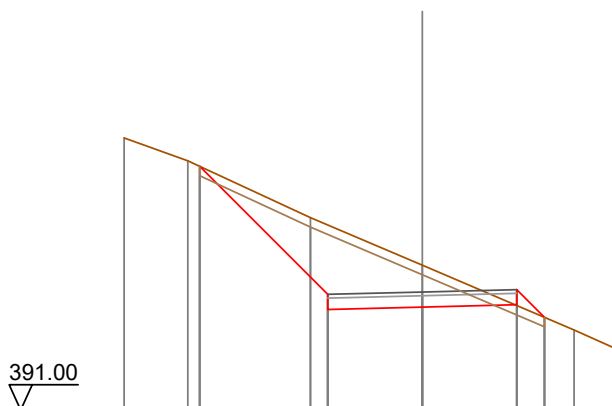

Quote Terreno		398.20		397.59		396.09		394.83		393.12		392.57
Quote Progetto			397.45		393.66		393.72		393.79	393.45		
Parziali				3.39		2.50		2.50		0.73		
Progressiva			-5.89		-2.50		0.00		2.50		3.23	
Dislivelli			0.00		-1.84		-1.11		0.02		0.00	

Sezione: 3
 Progressiva: 19.681
 Q. Progetto: 394.303

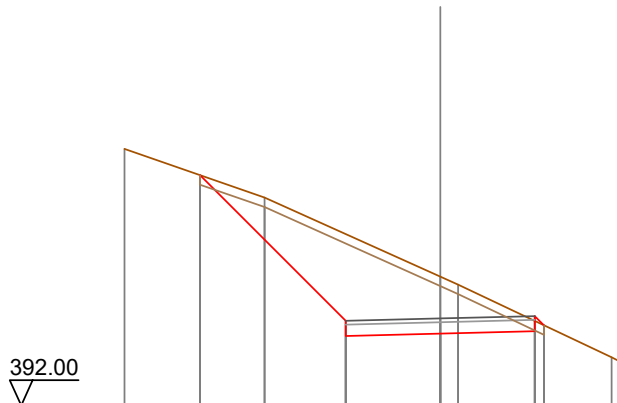

Quote Terreno		398.79		397.50		395.41	395.20		393.27	393.17
Quote Progetto			398.09		393.84		393.90		393.97	394.12
Parziali				3.85		2.50		2.50		
Progressiva			-6.35		-2.50		0.00		2.50	2.75
Dislivelli			0.00		-2.29		-1.51		-0.27	0.00

Sezione: 4
 Progressiva: 20.000
 Q. Progetto: 394.314

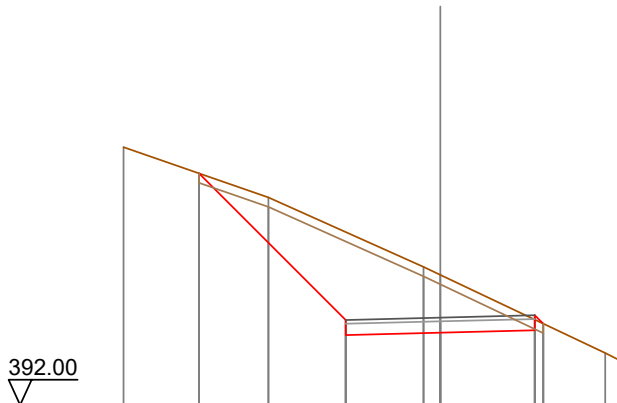

Quote Terreno		398.82		397.49		395.65	395.44		393.38	393.20
Quote Progetto			398.13		393.85		393.91		393.98	394.15
Parziali				3.88		2.50		2.50		
Progressiva			-6.38		-2.50		0.00		2.50	2.72
Dislivelli			-0.00		-2.32		-1.53		-0.28	-0.00

Sezione: 5
 Progressiva: 25.978
 Q. Progetto: 394.562

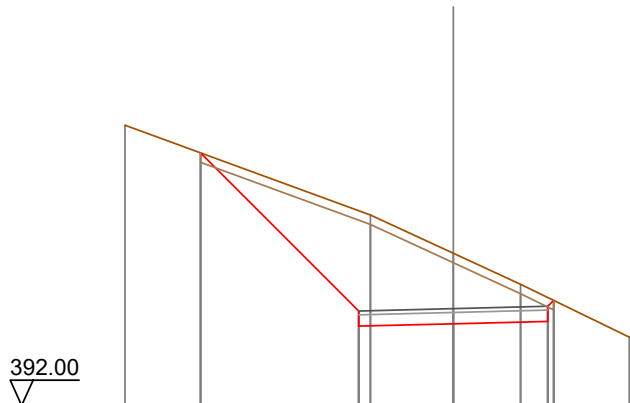

Quote Terreno		-399.41		-397.04	-396.03	-395.20		-393.81
Quote Progetto			398.68	394.10	394.16	394.22	394.78	
Parziali			4.18	2.50	2.50			
Progressiva			-6.68	-2.50	0.00	2.50	2.66	
Dislivelli			0.00	-2.65	-1.87	-0.63	0.00	

Sezione: 6
 Progressiva: 30.160
 Q. Progetto: 394.778

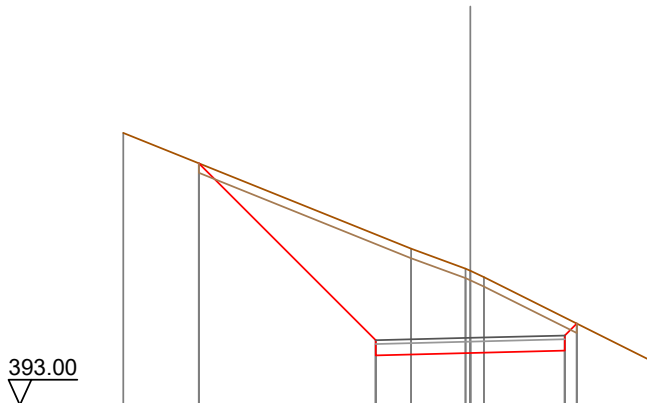

Quote Terreno		400.20		397.14	396.61	396.38		394.16
Quote Progetto			398.39	394.32	394.38	394.44	395.16	
Parziali			4.68	2.50	2.50	0.32		
Progressiva			-7.18	-2.50	0.00	2.50	2.82	
Dislivelli			0.00	-2.80	-2.17	-0.87	0.00	

Sezione: 7
 Progressiva: 39.408
 Q. Progetto: 395.380

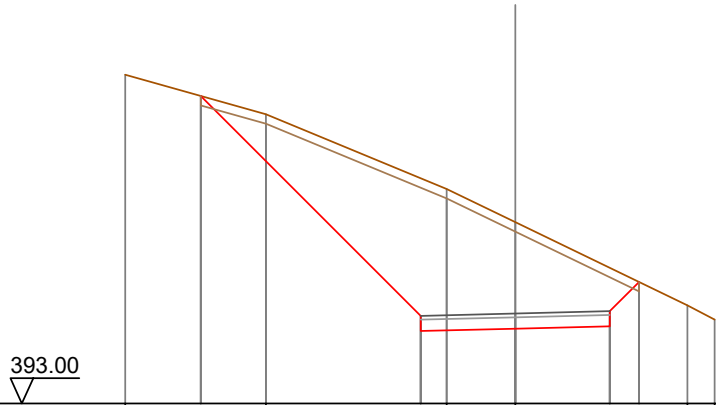

Quote Terreno		-401.69		-400.65		-398.67		-397.80		-395.60		-395.22
Quote Progetto			401.13			394.92		394.98		395.04		396.22
Parziali				5.82		2.50		2.50		0.77		
Progressiva			-8.32			-2.50		0.00		2.50		3.27
Dislivelli			-0.00			-3.64		-2.82		-1.55		0.00

Sezione: 8
 Progressiva: 40.000
 Q. Progetto: 395.424

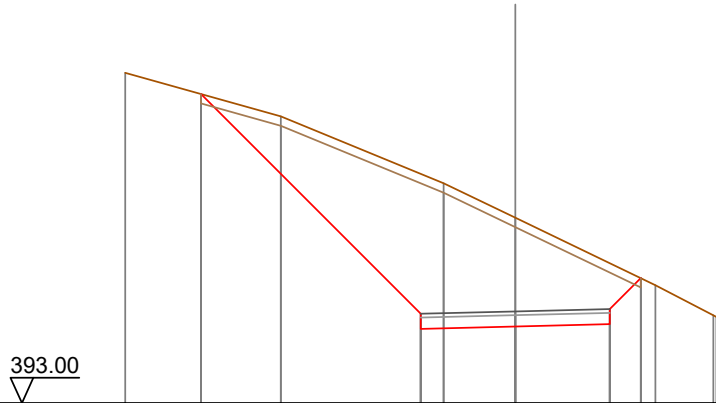

Quote Terreno		-401.74		-400.58		-398.81		-397.90		-396.12		-395.32		-395.28
Quote Progetto			401.18			394.96		395.02		395.09		396.31		
Parziali				5.81		2.50		2.50		0.82				
Progressiva			-8.31			-2.50		0.00		2.50		3.32		
Dislivelli			-0.00			-3.70		-2.88		-1.61		0.00		

Sezione: 9
 Progressiva: 48.655
 Q. Progetto: 396.154

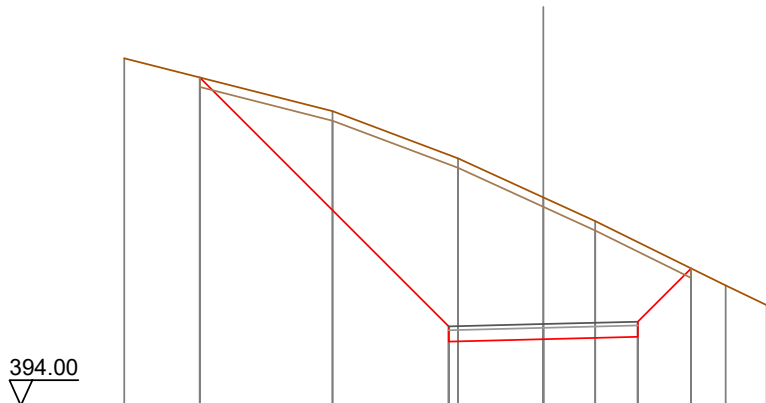

Quote Terreno	403.18	401.78	400.54	399.51	398.88	397.17	396.65
Quote Progetto	402.67		395.69	395.75	395.82	397.63	
Parziali		6.58	2.50	2.50	1.41		
Progressiva	-9.08		-2.50	0.00	2.50	3.91	
Dislivelli	0.00		-4.54	-3.75	-2.50	0.00	

Sezione: 10
 Progressiva: 60.000
 Q. Progetto: 397.164

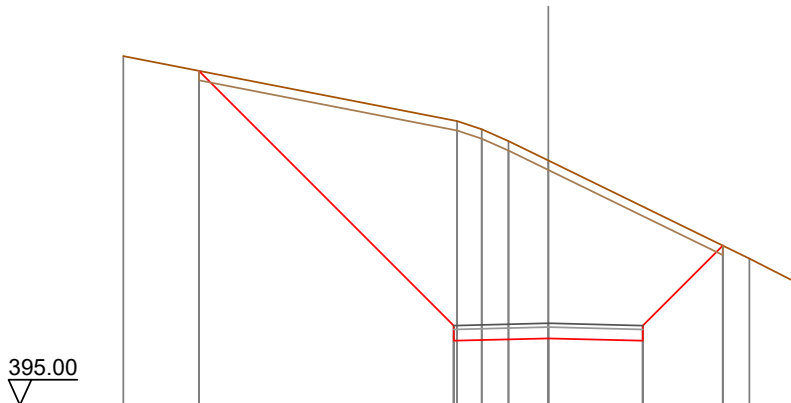

Quote Terreno	404.23		402.51	402.30	401.98		398.87	398.21
Quote Progetto	403.84		396.70	402.30	401.98		399.22	
Parziali		6.74	2.50	2.50	2.12			
Progressiva	-9.24		-2.50	0.00	2.50	4.62		
Dislivelli	0.00		-5.43	-4.70	-3.55	0.00		

Sezione: 11
 Progressiva: 67.053
 Q. Progetto: 397.677

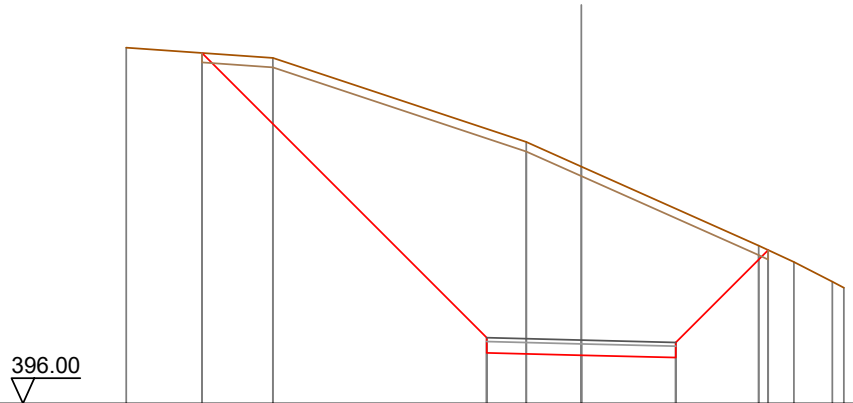

Quote Terreno		405.41		405.14		402.92		402.27		400.18		399.74		399.22		399.06
Quote Progetto			405.27			397.34		397.28		397.21		400.06				
Parziali				7.53			2.50		2.50		2.44					
Progressiva			-10.03			-2.50		0.00		2.50		4.94				
Dislivelli			0.00			-5.52		-4.99		-3.94		-0.00				

Sezione: 12
 Progressiva: 69.026
 Q. Progetto: 397.803

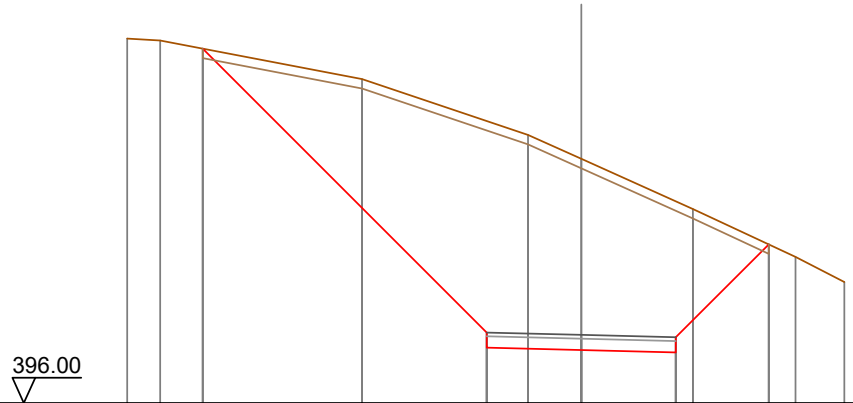

Quote Terreno		405.64		405.59		404.57		403.09		402.46		401.13		399.87		399.20
Quote Progetto			405.37			397.47		397.40		397.34		400.20				
Parziali				7.51			2.50		2.50		2.46					
Progressiva			-10.01			-2.50		0.00		2.50		4.96				
Dislivelli			-0.00			-5.60		-5.06		-4.00		-0.00				

Sezione: 13
 Progressiva: 70.000
 Q. Progetto: 397.862

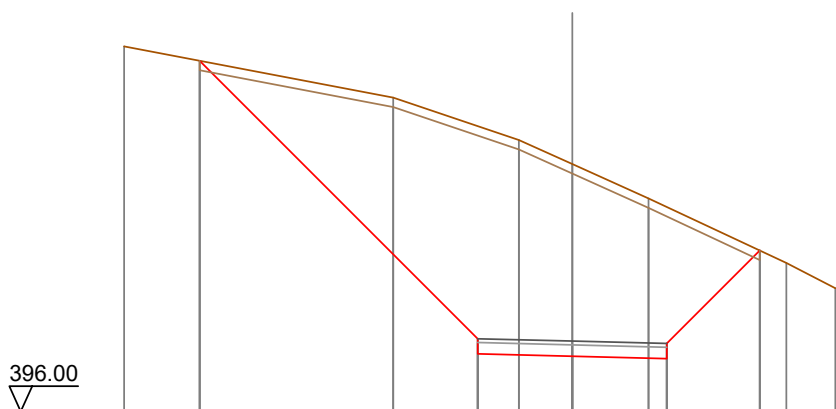

Quote Terreno		-405.66		-404.30		-403.18		-402.54		-401.63		-399.93		-399.26
Quote Progetto			405.28			397.52		397.46		397.40		400.26		
Parziali				7.35		2.50		2.50		2.46				
Progressiva			-9.85			-2.50		0.00		2.50		4.96		
Dislivelli			0.00			-5.62		-5.08		-4.01		0.00		

Sezione: 14
 Progressiva: 70.999
 Q. Progetto: 397.921

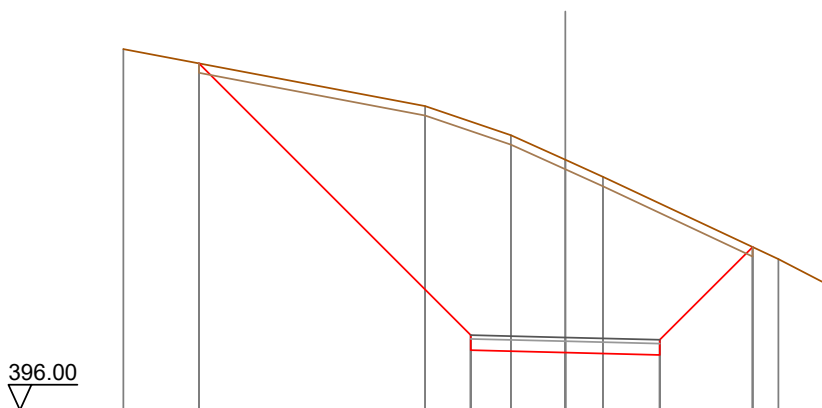

Quote Terreno		-405.55		-404.04		-403.27		-402.62		-402.17		-399.99		-399.31
Quote Progetto			405.17			397.58		397.52		397.46		400.31		
Parziali				7.19		2.50		2.50		2.45				
Progressiva			-9.69			-2.50		0.00		2.50		4.95		
Dislivelli			0.00			-5.65		-5.10		-4.01		0.00		

Sezione: 15
 Progressiva: 80.000
 Q. Progetto: 398.359

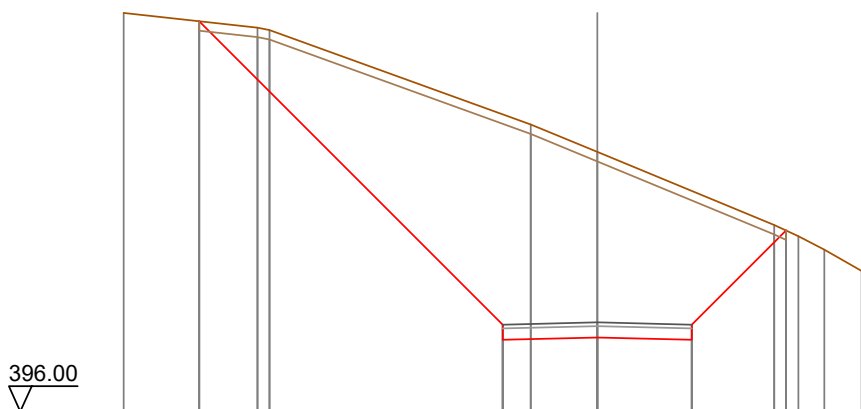

Quote Terreno		-406.54	-406.15	-406.09	-403.59	-402.87	-400.93	-400.63	-400.28	-399.72
Quote Progetto			406.32		397.90	397.96	397.90	400.79		
Parziali			8.03		2.50	2.50	2.49			
Progressiva			-10.53		-2.50	0.00	2.50	4.99		
Dislivelli			0.00		-5.56	-4.91	-3.94	0.00		

Sezione: 16
 Progressiva: 100.000
 Q. Progetto: 398.751

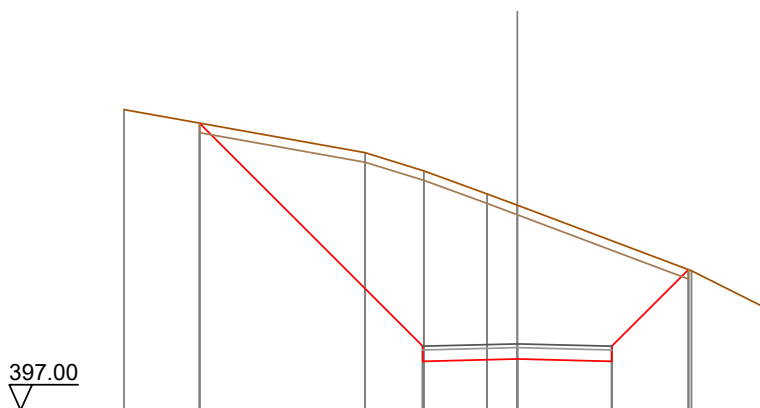

Quote Terreno		-404.95	-403.81	-403.33	-402.72	-402.42	-400.69	-399.72
Quote Progetto			404.59	398.29	398.35	398.29	400.72	
Parziali			5.90	2.50	2.50	2.03		
Progressiva			-8.40	-2.50	0.00	2.50	4.53	
Dislivelli			0.00	-4.65	-4.07	-3.19	0.00	

Sezione: 17
 Progressiva: 120.000
 Q. Progetto: 398.348

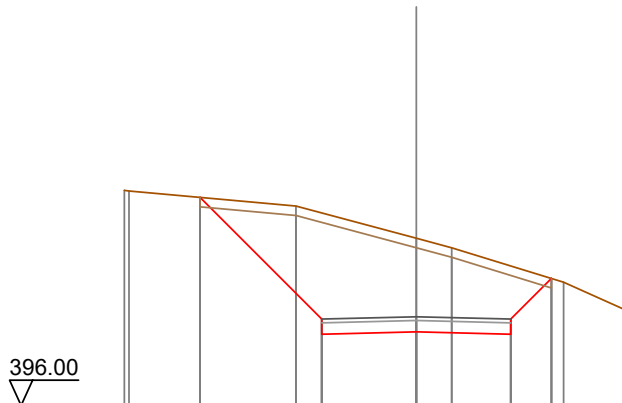

Quote Terreno	401.69	401.67	401.27	400.42	400.17	399.26	398.51
Quote Progetto		401.50	397.89	397.95	397.89	399.36	
Parziali			3.22	2.50	2.50	1.08	
Progressiva		-5.72	-2.50	0.00	2.50	3.58	
Dislivelli		0.00	-2.81	-2.48	-1.81	0.00	

Sezione: 18
 Progressiva: 121.076
 Q. Progetto: 398.309

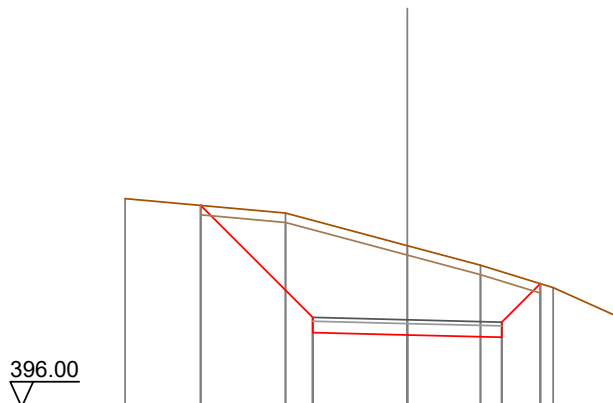

Quote Terreno	401.52	401.13	400.27	399.75	399.16	398.41
Quote Progetto		401.33	397.97	397.91	397.85	399.27
Parziali		2.96	2.50	2.50	1.02	
Progressiva		-5.46	-2.50	0.00	2.50	3.52
Dislivelli		0.00	-2.57	-2.36	-1.73	0.00

Sezione: 19
 Progressiva: 127.008
 Q. Progetto: 398.093

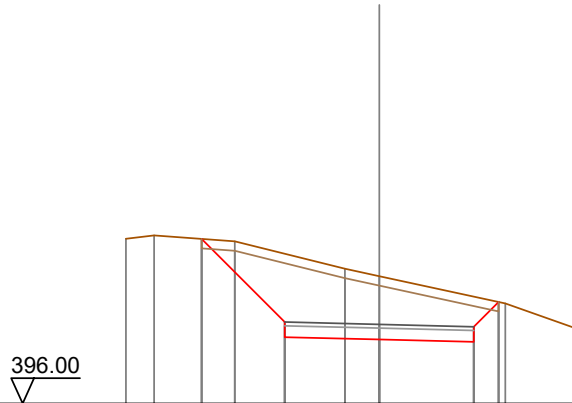

Quote Terreno	-400.36	-400.45	-400.29	-399.56	-399.37	-398.65	-398.00
Quote Progetto		400.35	397.76	397.69	397.63	398.68	
Parziali			2.20	2.50	2.50	0.65	
Progressiva		-4.70	-2.50	0.00	2.50	3.15	
Dislivelli		-0.00	-1.81	-1.67	-1.20	-0.00	

Sezione: 20
 Progressiva: 130.000
 Q. Progetto: 397.984

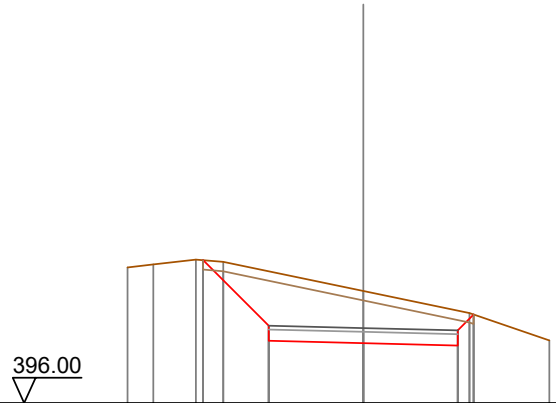

Quote Terreno	399.59	399.67	399.80	399.74	398.97	398.38	397.66
Quote Progetto			399.78	397.65	397.58	397.52	396.34
Parziali			1.73	2.50	2.50	0.42	
Progressiva		-4.23	-2.50	0.00	2.50	2.92	
Dislivelli		0.00	-1.44	-1.38	-0.92	0.00	

Sezione: 21
 Progressiva: 132.939
 Q. Progetto: 397.877

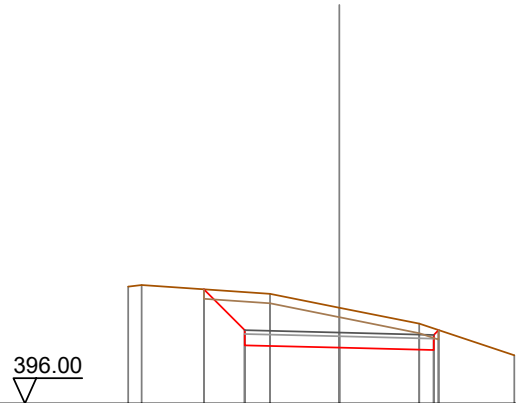

Quote Terreno		399.09	398.13						
Quote Progetto				399.02	397.54		397.48	398.53	397.28
Parziali				1.08	2.50		2.50		
Progressiva				-3.58	-2.50		0.00	2.50	2.63
Dislivelli				-0.00	-1.01		-1.06	-0.57	-0.00

Sezione: 22
 Progressiva: 140.000
 Q. Progetto: 397.621

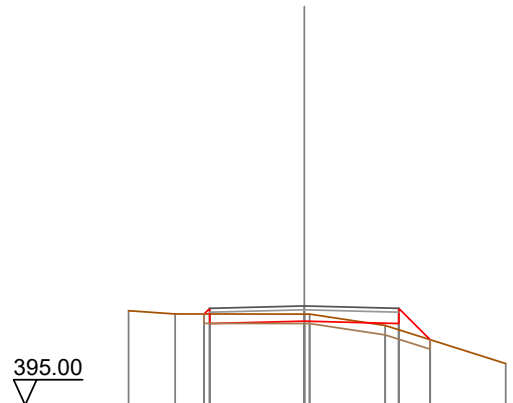

Quote Terreno				397.50	397.41		397.41	397.41	397.11	396.10
Quote Progetto						397.41	397.16		397.22	397.16
Parziali						2.50	2.50		0.83	
Progressiva				-2.65	-2.50		0.00	2.50	3.33	
Dislivelli				-0.00	0.15		-0.19	0.17	-0.00	

Sezione: 23
 Progressiva: 143.333
 Q. Progetto: 397.508

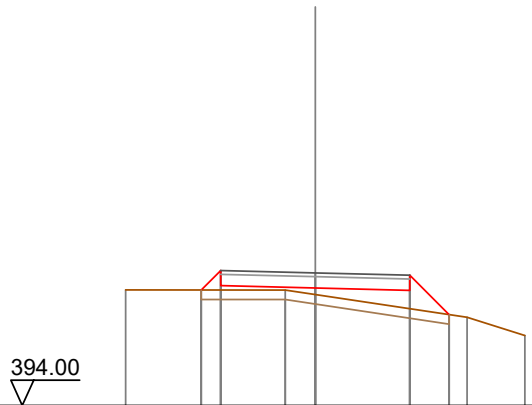

Quote Terreno		397.06			397.05	396.93			396.33	395.85
Quote Progetto			397.06	397.17		397.11		397.05	396.40	
Parziali			0.51	2.50		2.50		1.04		
Progressiva			-3.01	-2.50		0.00		2.50	3.54	
Dislivelli			-0.00	0.52		0.17		0.49	-0.00	

Sezione: 24
 Progressiva: 150.000
 Q. Progetto: 397.348

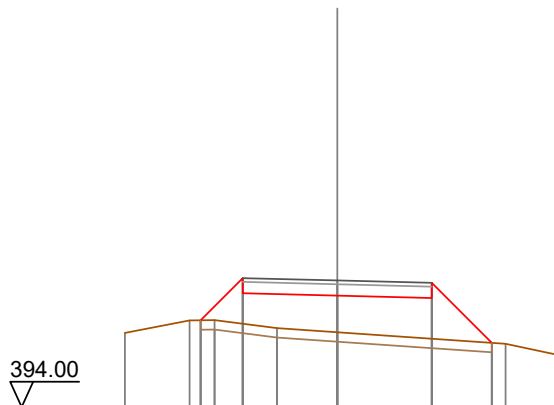

Quote Terreno		395.96			396.09	395.98			395.68	395.33
Quote Progetto			396.30	397.01		396.95		396.89	395.70	
Parziali			1.11	2.50		2.50		1.58		
Progressiva			-3.61	-2.50		0.00		2.50	4.08	
Dislivelli			-0.00	1.21		0.97		1.08	0.00	

Sezione: 25
 Progressiva: 150.847
 Q. Progetto: 397.334

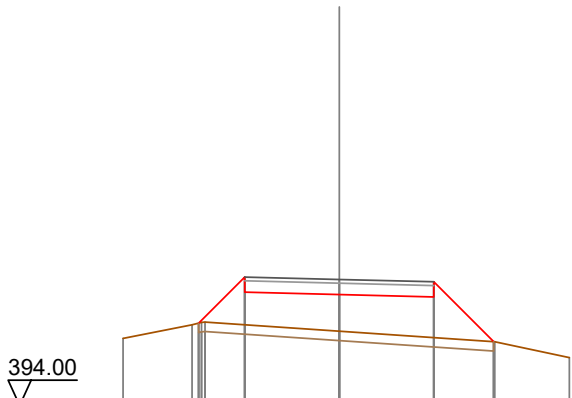

Quote Terreno		395.77	396.13	396.21	395.97	395.69	395.27
Quote Progetto			396.18	397.00	396.83	396.87	395.69
Parziali			1.22	2.50	2.50	1.58	
Progressiva			-3.72	-2.50	0.00	2.50	4.08
Dislivelli			0.00	1.26	0.97	1.08	-0.00

Sezione: 26
 Progressiva: 158.361
 Q. Progetto: 397.274

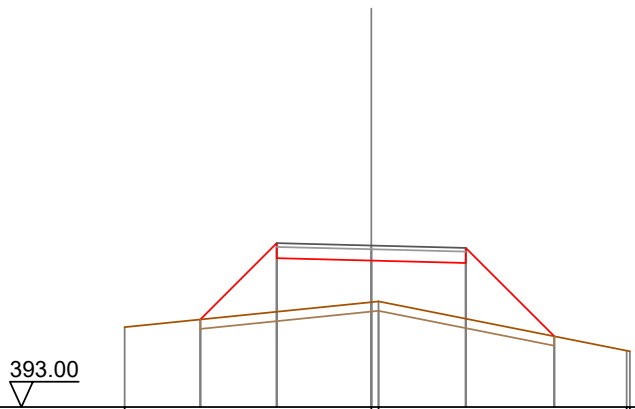

Quote Terreno		395.11	395.78	395.80	394.49	394.48	
Quote Progetto			395.32	396.94	396.87	396.81	394.87
Parziali			2.02	2.50	2.50	2.34	
Progressiva			-4.52	-2.50	0.00	2.50	4.84
Dislivelli			-0.00	1.82	1.10	1.47	0.00

Sezione: 27
 Progressiva: 160.000
 Q. Progetto: 397.276

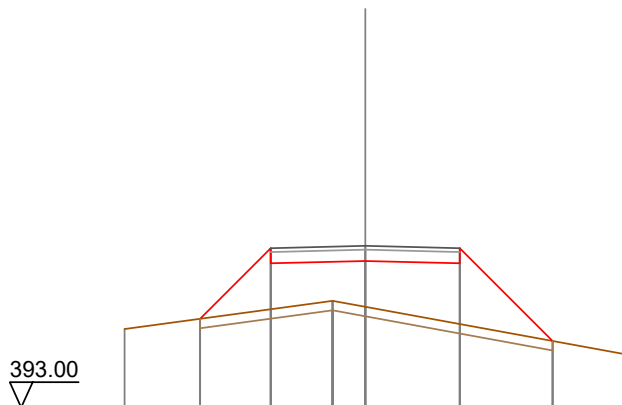

Quote Terreno		395.08		395.82	395.66		394.39
Quote Progetto			395.95	396.81	396.88	396.81	394.76
Parziali			1.87	2.50	2.50	2.46	
Progressiva			-4.37	-2.50	0.00	2.50	4.96
Dislivelli			0.00	1.61	1.21	1.61	-0.00

Sezione: 28
 Progressiva: 176.153
 Q. Progetto: 397.582

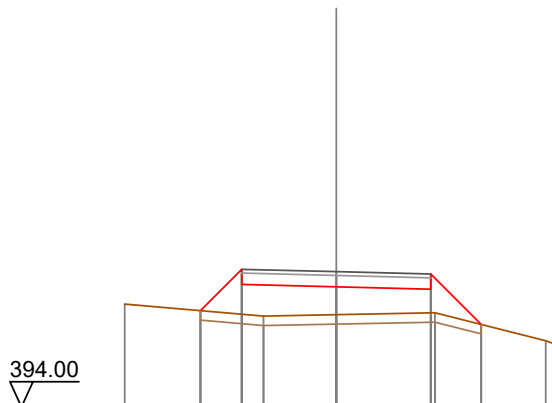

Quote Terreno		396.72		396.41	396.44	396.50	395.75
Quote Progetto			396.55	397.24	397.18	397.12	396.19
Parziali			1.09	2.50	2.50	1.33	
Progressiva			-3.59	-2.50	0.00	2.50	3.83
Dislivelli			0.00	1.19	0.74	0.63	0.00

Sezione: 29
 Progressiva: 180.000
 Q. Progetto: 397.732

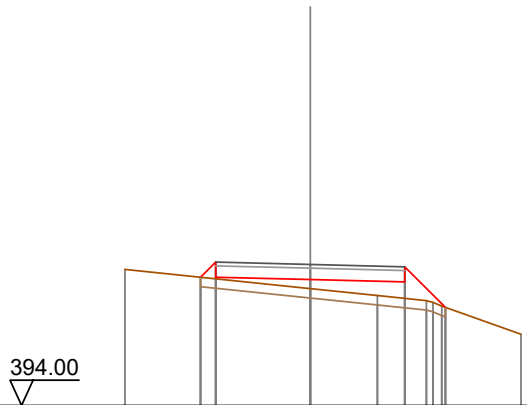

Quote Terreno			397.60			397.09		396.91		396.77		396.63		395.89
Quote Progetto				397.39	397.39		397.33		397.27		396.60			
Parziali				0.40	2.50		2.50		1.07					
Progressiva				-2.90	-2.50		0.00		2.50		3.57			
Dislivelli				0.00	0.44		0.24		0.44		-0.00			

Sezione: 30
 Progressiva: 184.381
 Q. Progetto: 397.938

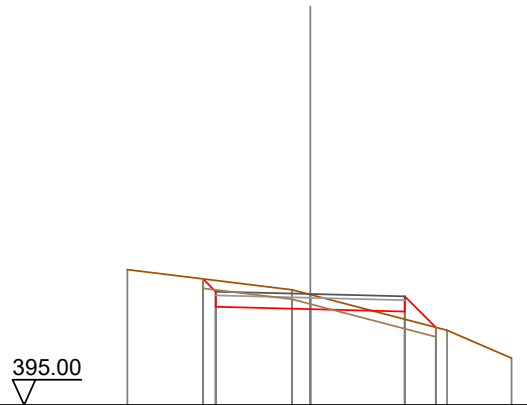

Quote Terreno						398.05		397.92		396.98		396.24
Quote Progetto				398.34	397.60		397.54		397.48		397.05	
Parziali				0.34	2.50		2.50		0.82			
Progressiva				-2.84	-2.50		0.00		2.50		3.32	
Dislivelli				0.00	-0.29		-0.38		0.21		0.00	

Sezione: 31
 Progressiva: 190.000
 Q. Progetto: 398.260

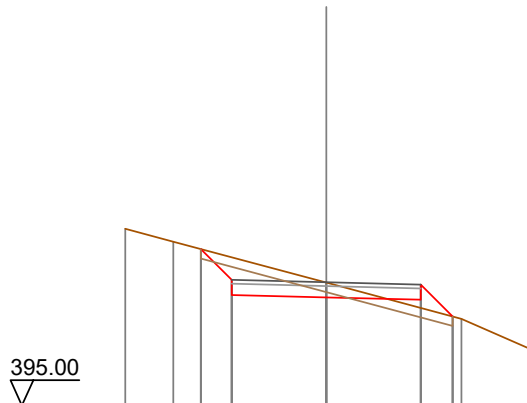

Quote Terreno	-399.68	-399.33			-398.25		-397.29	-396.52
Quote Progetto			399.14	397.92	397.86	397.80	397.35	
Parziali			0.82	2.50	2.50	0.84		
Progressiva		-3.32	-2.50		0.00	2.50	3.34	
Dislivelli		0.00	-0.60		-0.39	0.22	0.00	

Sezione: 32
 Progressiva: 192.608
 Q. Progetto: 398.431

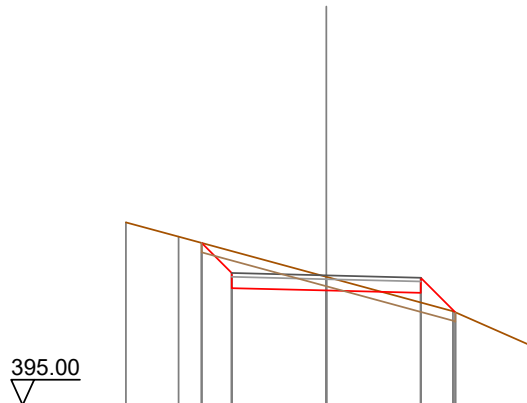

Quote Terreno	-399.83	-399.46			-398.39		-397.48	-396.57
Quote Progetto			399.29	398.09	398.03	397.97	397.45	
Parziali			0.80	2.50	2.50	0.92		
Progressiva		-3.30	-2.50		0.00	2.50	3.42	
Dislivelli		0.00	-0.58		-0.36	0.26	0.00	

Sezione: 33
 Progressiva: 200.000
 Q. Progetto: 398.990

395.00

Quote Terreno	-400.18	-399.50	-398.75	-398.24	-398.09	-397.78	-396.37
Quote Progetto		399.62	398.53	398.59	398.53	397.34	
Parziali		0.69	2.50	2.50	1.59		
Progressiva		-3.19	-2.50	0.00	2.50	4.09	
Dislivelli		0.00	-0.50	-0.17	0.45	0.00	

Sezione: 34
 Progressiva: 220.000
 Q. Progetto: 401.057

395.00

Quote Terreno	-403.98	-402.84	-401.18	-401.12	-397.00	
Quote Progetto		403.14	400.59	400.66	400.59	398.14
Parziali		2.14	2.50	2.50	2.85	
Progressiva		-4.64	-2.50	0.00	2.50	5.35
Dislivelli		-0.00	-1.24	-0.52	0.82	0.00

Sezione: 35
 Progressiva: 227.879
 Q. Progetto: 402.067

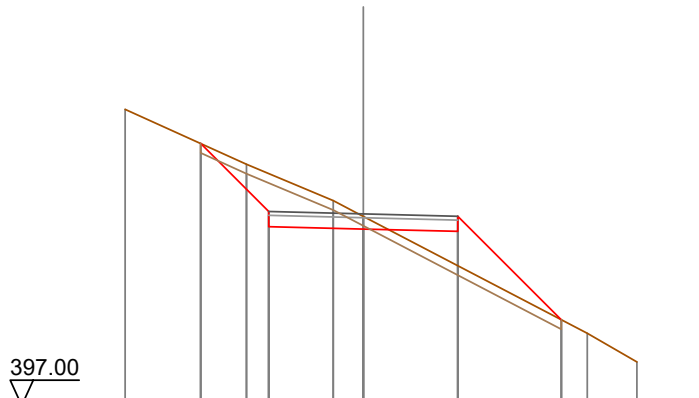

Quote Terreno	-404.83	-403.38	-402.42	-402.00	-398.91	-398.15
Quote Progetto		403.93	401.73	401.67	401.60	399.27
Parziali		1.80	2.50	2.50	2.74	
Progressiva		-4.30	-2.50	0.00	2.50	5.24
Dislivelli		0.00	-1.01	-0.34	0.91	0.00

Sezione: 36
 Progressiva: 230.000
 Q. Progetto: 402.342

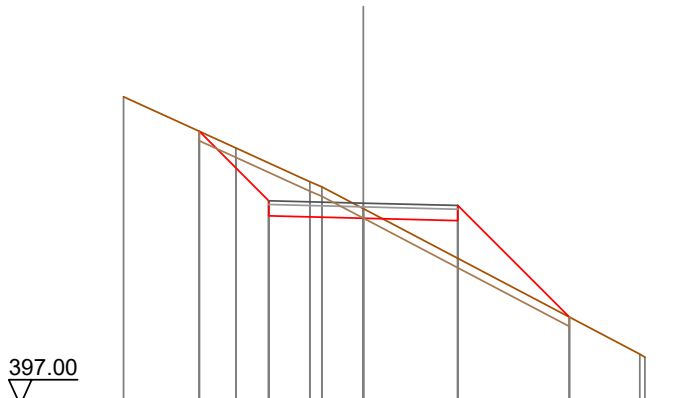

Quote Terreno	-405.15	-403.80	-402.91	-402.77	-402.20	-398.35	-398.27
Quote Progetto		404.24	402.00	401.94	401.88	399.33	398.27
Parziali		1.84	2.50	2.50	2.95		
Progressiva		-4.34	-2.50	0.00	2.50	5.45	
Dislivelli		0.00	-1.00	-0.25	1.00	0.00	

Sezione: 37
 Progressiva: 231.743
 Q. Progetto: 402.567

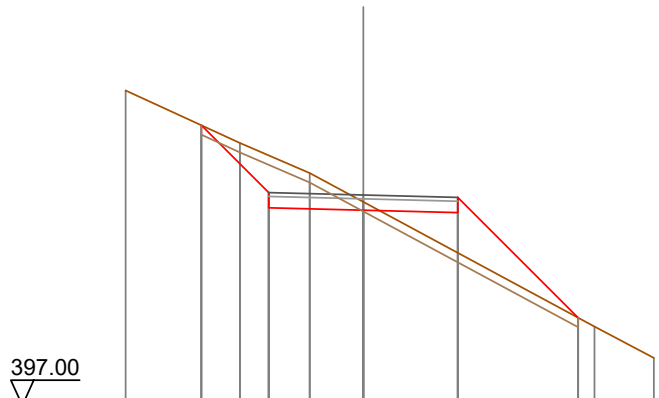

Quote Terreno		-405.33		-403.94		-403.15		-402.39		-399.09		-398.26
Quote Progetto			404.41		402.23		402.17		402.10		399.32	
Parziali				1.78		2.50		2.50		3.18		
Progressiva			-4.28		-2.50		0.00		2.50		5.68	
Dislivelli			-0.00		-0.99		-0.22		1.07		-0.00	

Sezione: 38
 Progressiva: 235.607
 Q. Progetto: 403.066

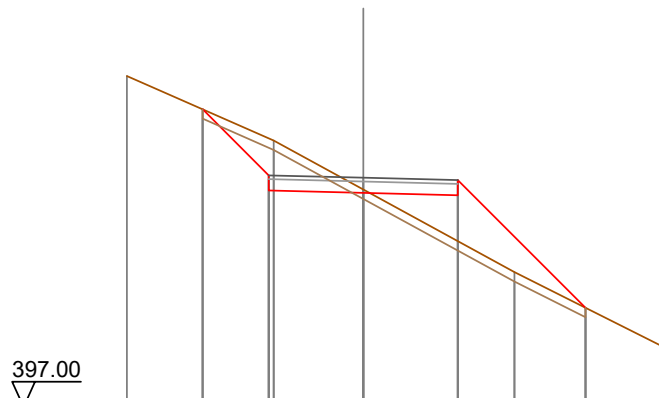

Quote Terreno		-405.76		-404.05		-402.76		-400.57		-398.62	
Quote Progetto			404.88		402.73		402.67		402.60		399.63
Parziali				1.75		2.50		2.50		3.38	
Progressiva			-4.25		-2.50		0.00		2.50		5.88
Dislivelli			-0.00		-0.98		-0.09		1.21		0.00

Sezione: 39
 Progressiva: 240.000
 Q. Progetto: 403.634

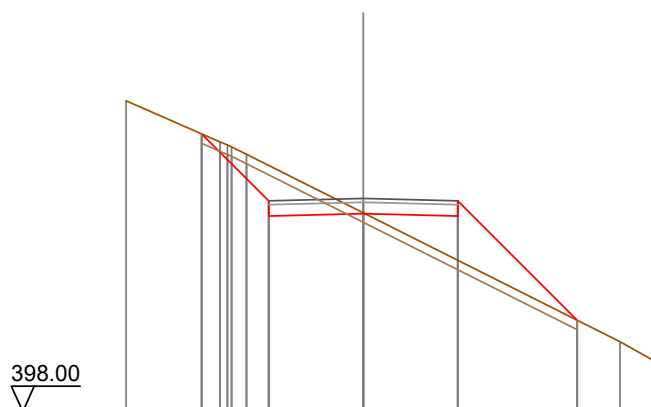

Quote Terreno		406.22	405.13	404.80	403.25			399.85	399.36
Quote Progetto			405.34	403.17	403.23	403.17		400.41	
Parziali			1.77	2.50	2.50	3.16			
Progressiva			-4.27	-2.50	0.00	2.50		5.66	
Dislivelli			0.00	-0.94	-0.02	1.17		-0.00	

Sezione: 40
 Progressiva: 257.976
 Q. Progetto: 405.958

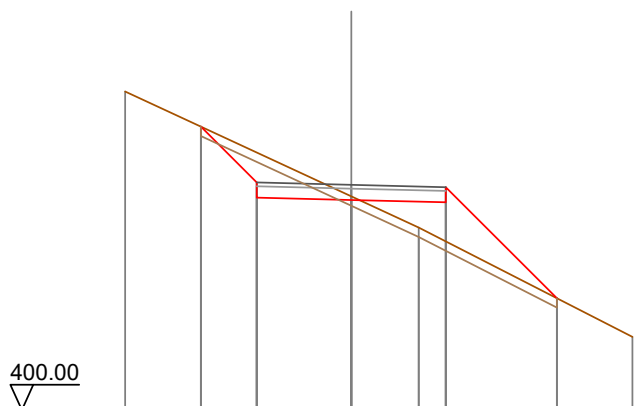

Quote Terreno		408.43			405.65				401.94
Quote Progetto			407.50	405.62	405.56	405.50		402.96	
Parziali			1.48	2.50	2.50	2.94			
Progressiva			-3.98	-2.50	0.00	2.50		5.44	
Dislivelli			0.00	-0.79	-0.10	1.03		0.00	

Sezione: 41
 Progressiva: 258.452
 Q. Progetto: 406.019

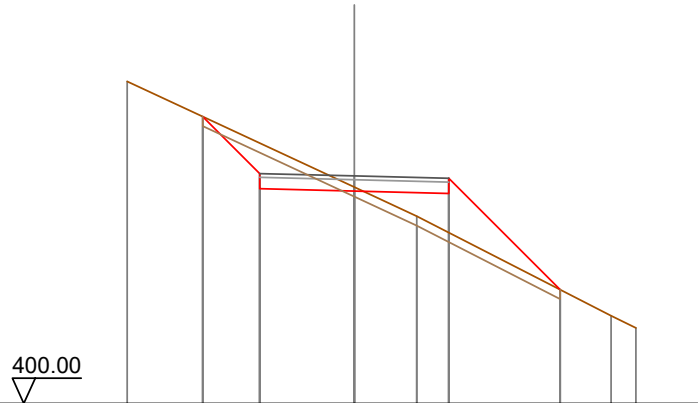

Quote Terreno	-408.52			405.72	-404.96		-402.32	-402.00
Quote Progetto		407.59	405.68	405.62	405.66		403.01	
Parziali		1.51	2.50	2.50	2.95			
Progressiva		-4.01	-2.50	0.00	2.50		5.45	
Dislivelli		0.00	-0.81	-0.11	1.04		-0.00	

Sezione: 42
 Progressiva: 258.928
 Q. Progetto: 406.081

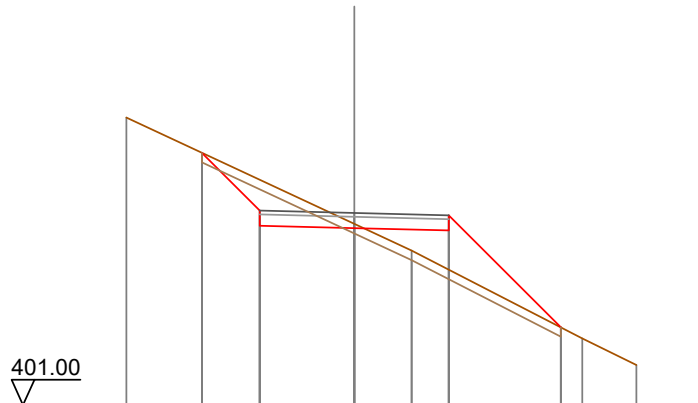

Quote Terreno	-408.60			405.79	-405.08		402.76	-402.06
Quote Progetto		407.67	405.74	405.68	405.62		403.06	
Parziali		1.53	2.50	2.50	2.96			
Progressiva		-4.03	-2.50	0.00	2.50		5.46	
Dislivelli		0.00	-0.82	-0.11	1.04		0.00	

Sezione: 43
 Progressiva: 260.000
 Q. Progetto: 406.219

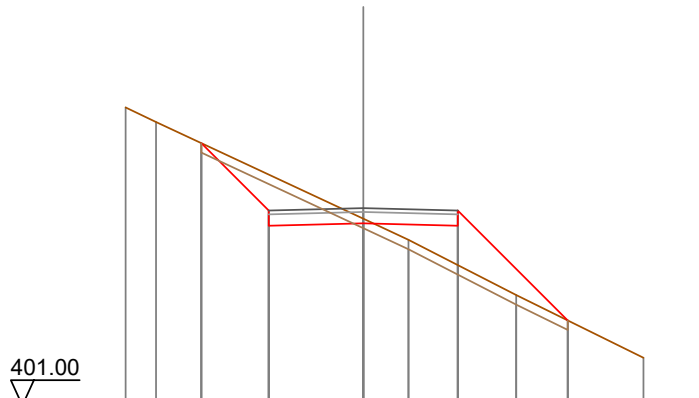

Quote Terreno		-408.88	-408.50		405.94	-405.38	-403.92	-402.26
Quote Progetto			407.94	405.76	405.82	405.76	403.25	
Parziali				1.78	2.50	2.50	2.91	
Progressiva			-4.28	-2.50	0.00	2.50	5.41	
Dislivelli			0.00	-0.95	-0.12	1.04	-0.00	

Sezione: 44
 Progressiva: 268.136
 Q. Progetto: 407.271

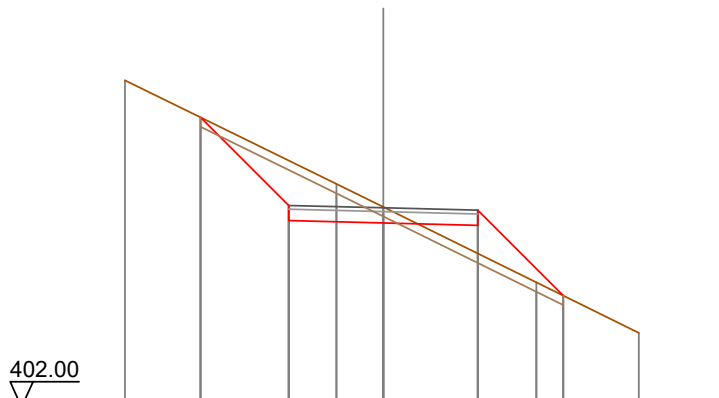

Quote Terreno		410.64		407.91	407.30		405.30	403.96
Quote Progetto			409.66	406.93	406.87	406.81	404.95	
Parziali			2.33	2.50	2.50	2.26		
Progressiva			-4.83	-2.50	0.00	2.50	4.76	
Dislivelli			0.00	-1.19	-0.42	0.74	-0.00	

Sezione: 45
 Progressiva: 270.000
 Q. Progetto: 407.512

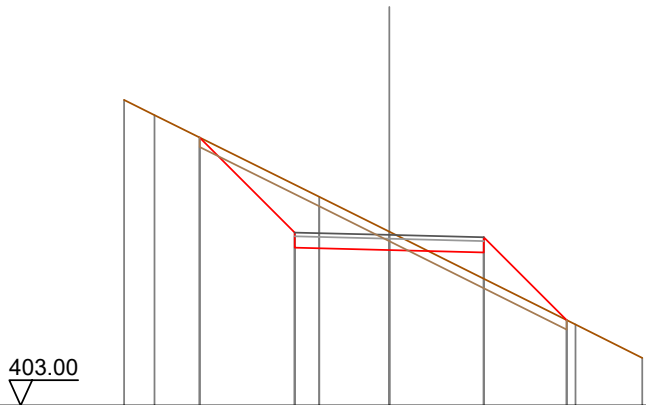

Quote Terreno		411.08	410.68	408.52	407.60	405.14	404.26
Quote Progetto			410.09	407.17	407.11	407.05	405.26
Parziali			2.51	2.50	2.50	2.19	
Progressiva			-5.01	-2.50	0.00	2.50	4.69
Dislivelli			0.00	-1.27	-0.49	0.70	0.00

Sezione: 46
 Progressiva: 270.827
 Q. Progetto: 407.619

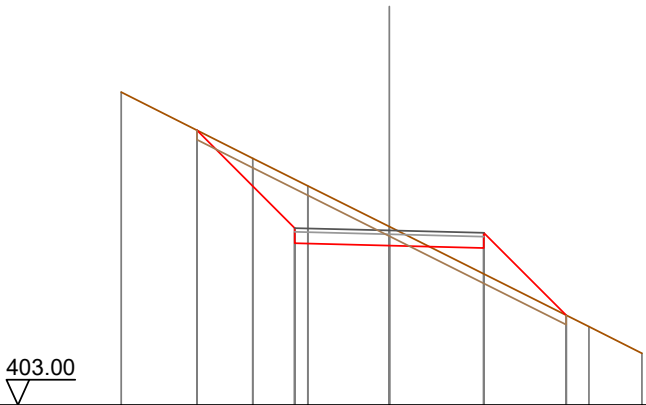

Quote Terreno		411.28	409.52	408.80	407.72	405.07	404.37
Quote Progetto			410.27	407.28	407.22	407.16	405.37
Parziali			2.59	2.50	2.50	2.18	
Progressiva			-5.09	-2.50	0.00	2.50	4.68
Dislivelli			0.00	-1.29	-0.50	0.69	-0.00

Sezione: 47
 Progressiva: 273.519
 Q. Progetto: 407.967

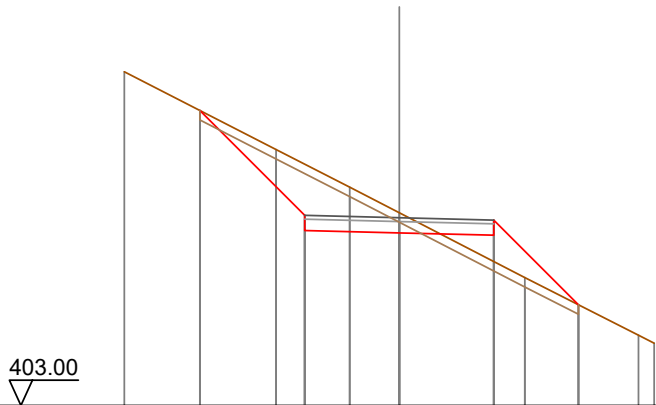

Quote Terreno		-411.83		-409.77	-408.77	-408.10		-406.38		-404.86	-404.65
Quote Progetto			410.80		407.63	407.57		407.50		405.66	
Parziali				2.77	2.50	2.50		2.24			
Progressiva			-5.27		-2.50	0.00		2.50		4.74	
Dislivelli			0.00		-1.35	-0.53		0.70		-0.00	

Sezione: 48
 Progressiva: 280.000
 Q. Progetto: 408.797

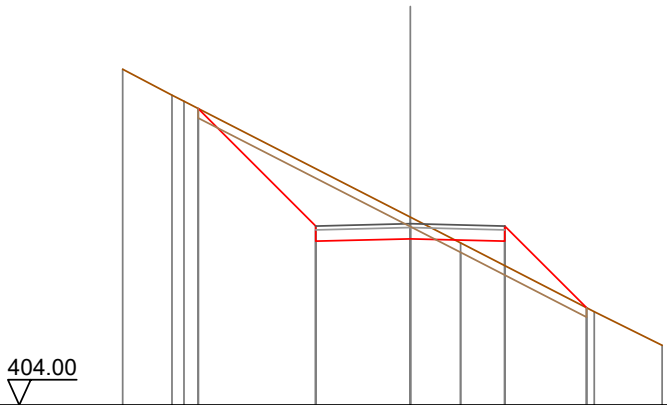

Quote Terreno		-412.88	-412.20	-412.04		-408.97		-408.29		-406.47	-405.58
Quote Progetto				411.84		408.33	408.40	408.33		406.57	
Parziali					3.11	2.50	2.50	2.16			
Progressiva				-5.61		-2.50	0.00	2.50		4.66	
Dislivelli				0.00		-1.52	-0.58	0.65		-0.00	

Sezione: 49
 Progressiva: 292.684
 Q. Progetto: 410.205

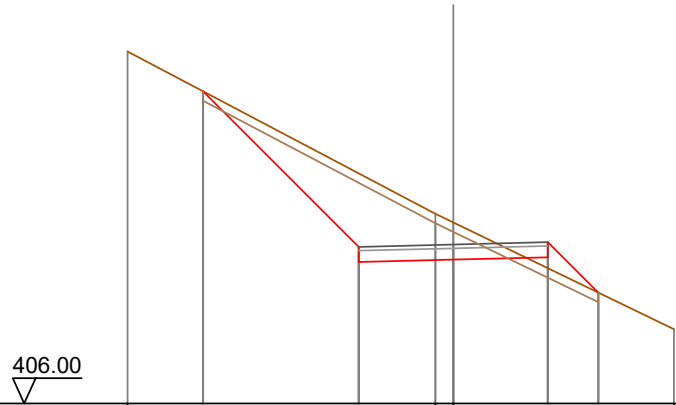

Quote Terreno		-415.31			-411.02	-410.79				-407.96
Quote Progetto			414.26		409.74		409.80		409.87	408.93
Parziali				4.11		2.50		2.50		1.34
Progressiva			-6.61		-2.50		0.00		2.50	3.84
Dislivelli			0.00		-1.94		-0.98		0.29	0.00

Sezione: 50
 Progressiva: 295.528
 Q. Progetto: 410.476

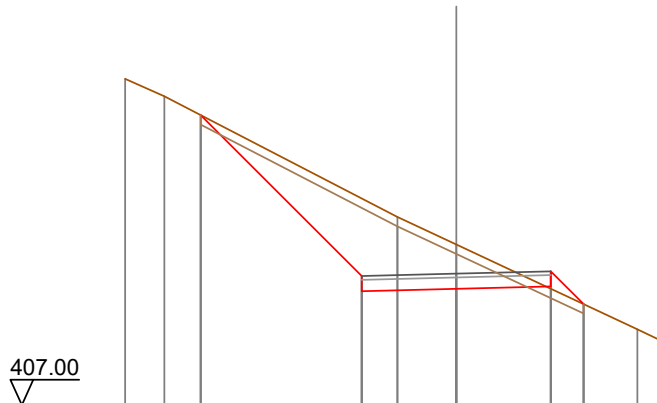

Quote Terreno		-415.63		-415.17		-411.98		-411.25		-409.00	-408.73
Quote Progetto				414.67		410.01		410.08		410.14	409.67
Parziali					4.26		2.50		2.50		0.87
Progressiva				-6.76		-2.50		0.00		2.50	3.37
Dislivelli				-0.00		-2.05		-1.17		0.06	0.00

Sezione: 51
 Progressiva: 298.372
 Q. Progetto: 410.730

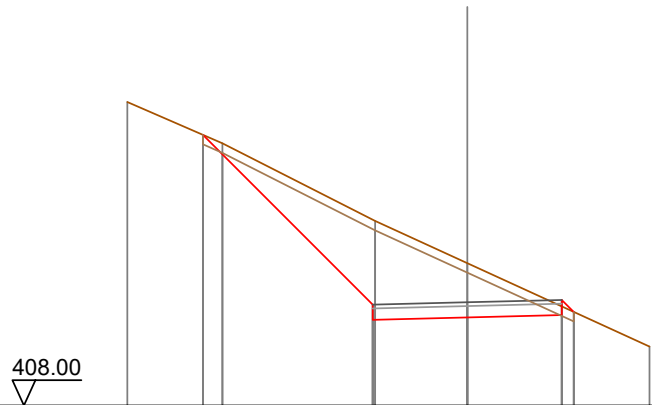

Quote Terreno	-416.03	-414.93	-412.88	-411.77	-409.56
Quote Progetto		415.16	410.27	410.33	410.39
Parziali		4.49	2.50	2.50	0.32
Progressiva		-6.99	-2.50	0.00	2.50
Dislivelli		0.00	-2.25	-1.44	-0.23

Sezione: 52
 Progressiva: 300.091
 Q. Progetto: 410.876

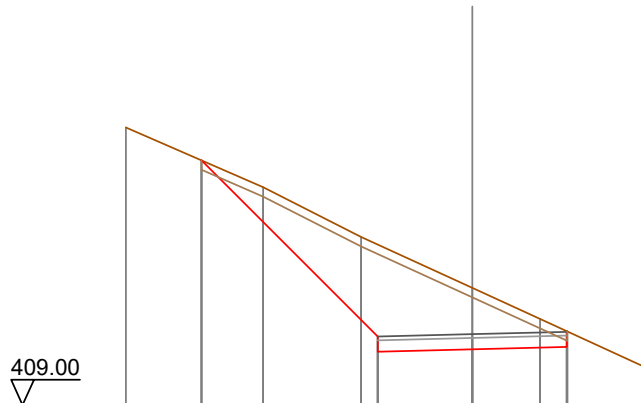

Quote Terreno	-416.34	-414.76	-413.45	-412.10	-411.28	-410.03
Quote Progetto		415.47	410.41	410.48	410.54	
Parziali		4.66	2.50	2.50		
Progressiva		-7.16	-2.50	0.00	2.50	
Dislivelli		0.00	-2.43	-1.62	-0.42	

Sezione: 53
 Progressiva: 308.317
 Q. Progetto: 411.491

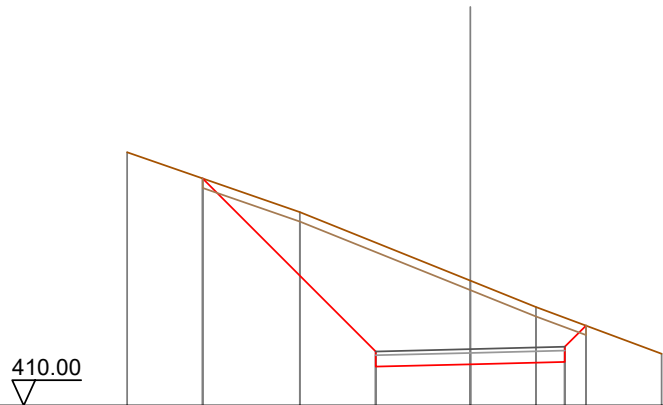

Quote Terreno	-416.70	-415.12	-411.03	-413.30	-412.61	-411.37
Quote Progetto	416.00	411.03	411.09	411.15	412.11	
Parziali		4.58	2.50	2.50	0.56	
Progressiva	-7.08	-2.50	0.00	2.50	3.06	
Dislivelli	0.00	-2.88	-2.21	-1.17	0.00	

Sezione: 54
 Progressiva: 310.000
 Q. Progetto: 411.600

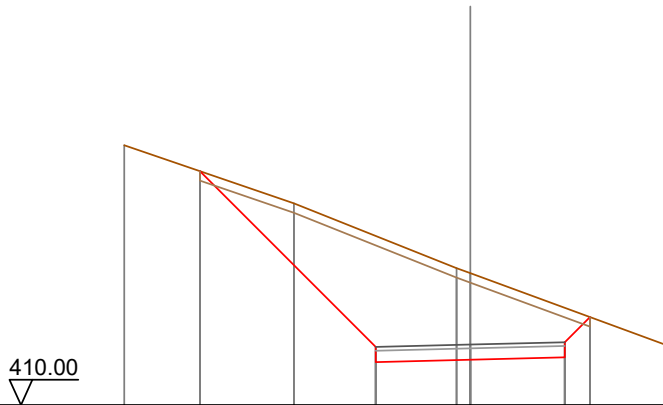

Quote Terreno	-416.87	-415.34	-413.62	-413.49	-411.59
Quote Progetto	416.19	411.14	411.20	411.26	412.33
Parziali		4.65	2.50	2.50	0.66
Progressiva	-7.15	-2.50	0.00	2.50	3.16
Dislivelli	-0.00	-2.94	-2.29	-1.31	0.00

Sezione: 55
 Progressiva: 316.543
 Q. Progetto: 411.970

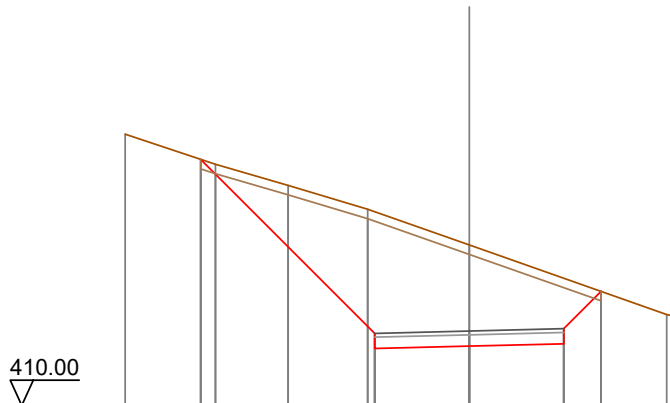

Quote Terreno	-417.18	-416.38	-415.82	-415.19	-414.25	-412.41	-412.35
Quote Progetto		416.51		411.51	411.57	411.63	413.02
Parziali			4.60	2.50	2.50	0.99	
Progressiva		-7.10		-2.50	0.00	2.50	3.49
Dislivelli		0.00		-3.22	-2.68	-1.73	0.00

Sezione: 56
 Progressiva: 318.947
 Q. Progetto: 412.084

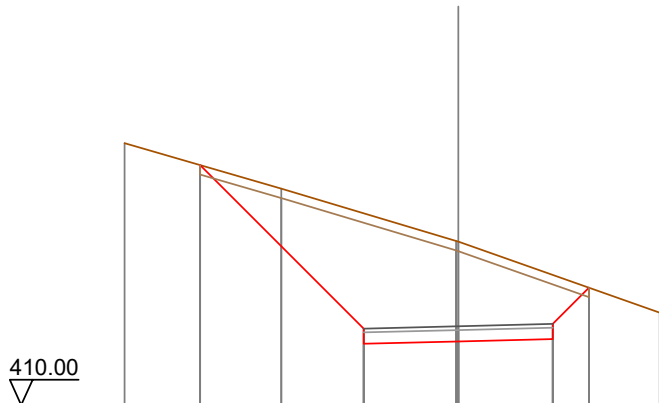

Quote Terreno	-416.93	-415.73	-414.34	-414.32	-412.44	-412.42	
Quote Progetto		416.35		411.68	411.75	413.10	
Parziali			4.33	2.50	2.50	0.96	
Progressiva		-6.83		-2.50	0.00	2.50	3.46
Dislivelli		0.00		-3.05	-2.64	-1.69	0.00

Sezione: 57
 Progressiva: 320.000
 Q. Progetto: 412.131

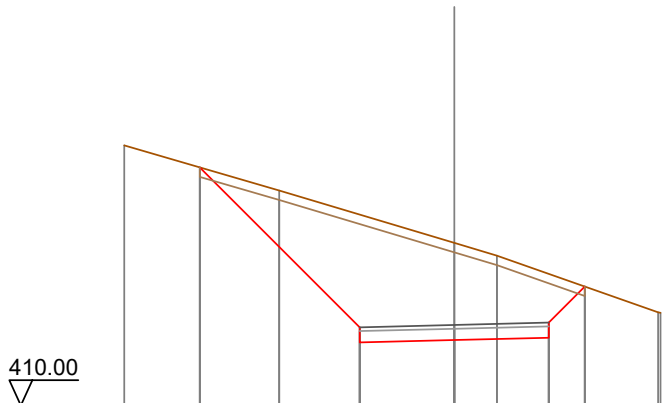

Quote Terreno		416.88		415.69		414.30		413.96		412.46	412.45
Quote Progetto			416.30		411.67		411.73		411.79		413.15
Parziali				4.23		2.50		2.50		0.95	
Progressiva			-6.73		-2.50		0.00		2.50		3.45
Dislivelli			0.00		-2.98		-2.57		-1.69		0.00

Sezione: 58
 Progressiva: 328.009
 Q. Progetto: 412.411

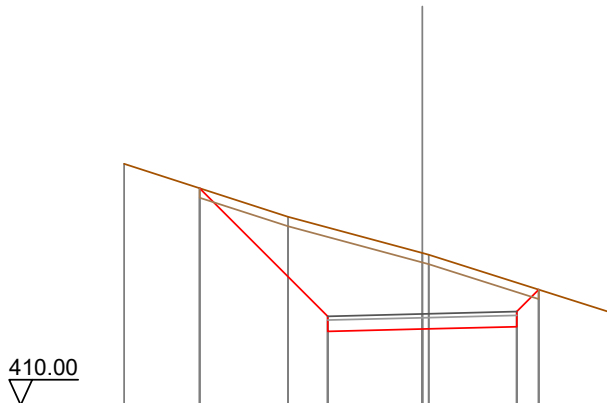

Quote Terreno		416.38		414.98		414.02		413.98		412.42	
Quote Progetto			415.73		411.95		412.01		412.07		413.05
Parziali				3.39		2.50		2.50		0.58	
Progressiva			-5.89		-2.50		0.00		2.50		3.08
Dislivelli			-0.00		-2.35		-2.01		-1.16		0.00

Sezione: 59
 Progressiva: 330.000
 Q. Progetto: 412.460

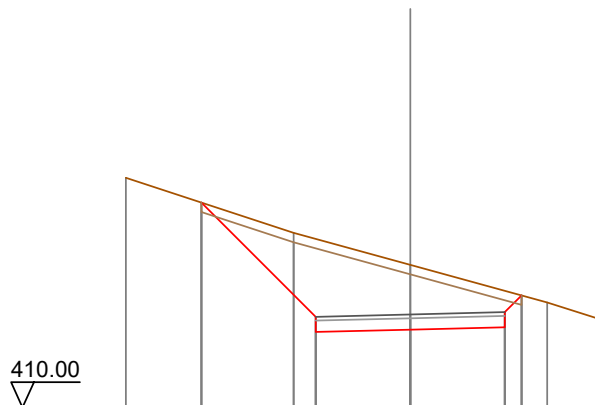

Quote Terreno	-416.07	-415.42	-414.62	-413.77	-412.78	-412.36
Quote Progetto		415.42	412.00	412.06	412.12	412.97
Parziali			3.02	2.50	2.50	0.44
Progressiva		-5.52	-2.50	0.00	2.50	2.84
Dislivelli		-0.00	-2.06	-1.71	-0.96	0.00

Sezione: 60
 Progressiva: 337.070
 Q. Progetto: 412.573

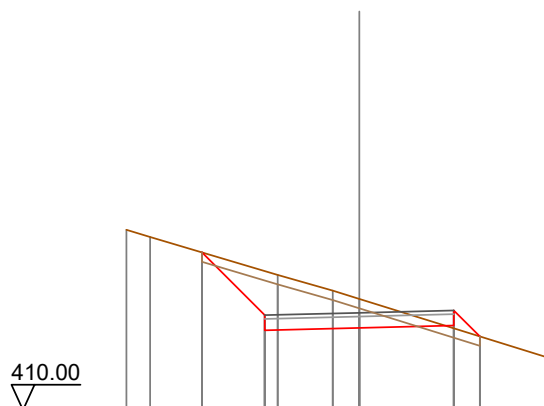

Quote Terreno	-414.77	-414.58	-413.57	-413.16	-412.94	-411.32
Quote Progetto		414.17	412.11	412.17	412.24	411.95
Parziali			1.66	2.50	2.50	0.69
Progressiva		-4.16	-2.50	0.00	2.50	3.19
Dislivelli		0.00	-1.17	-0.77	0.07	-0.00

Sezione: 61
 Progressiva: 340.012
 Q. Progetto: 412.590

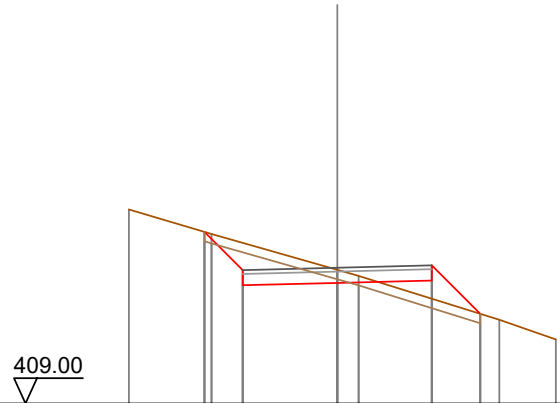

Quote Terreno	-414.13	413.48	412.54	412.37	411.21	-410.69
Quote Progetto		413.54	412.13	412.19	412.25	411.37
Parziali		1.01	2.50	2.50	1.28	
Progressiva		-3.51	-2.50	0.00	2.50	3.78
Dislivelli		0.00	-0.72	-0.34	0.48	-0.00

Sezione: 62
 Progressiva: 344.074
 Q. Progetto: 412.586

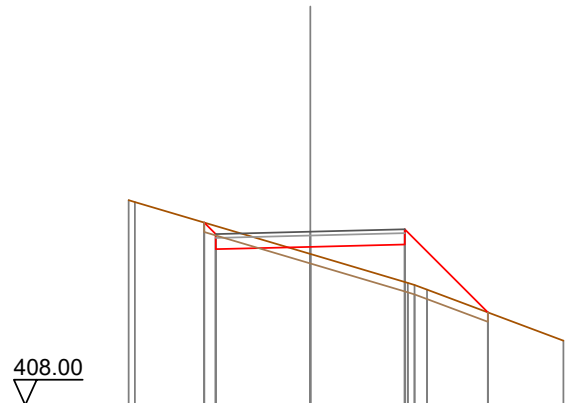

Quote Terreno	-413.42	413.37	412.00	411.23	409.70	
Quote Progetto		412.83	412.12	412.25	410.45	
Parziali		0.30	2.50	2.50	2.20	
Progressiva		-2.80	-2.50	0.00	2.50	4.70
Dislivelli		0.00	-0.21	0.19	0.99	0.00

Sezione: 63
 Progressiva: 348.136
 Q. Progetto: 412.548

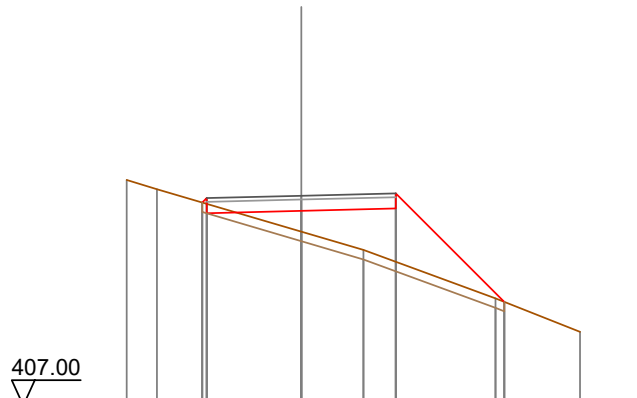

Quote Terreno	-412.96	-412.72	-412.37	-412.09	-411.60	-411.11	-409.83	-408.95
Quote Progetto			412.37	412.09	412.15	412.21	409.74	
Parziali				2.50	2.50	2.87		
Progressiva		-2.62	-2.50	0.00	2.50	5.37		
Dislivelli		0.00	0.15	0.55	1.41	0.00		

Sezione: 64
 Progressiva: 360.000
 Q. Progetto: 412.250

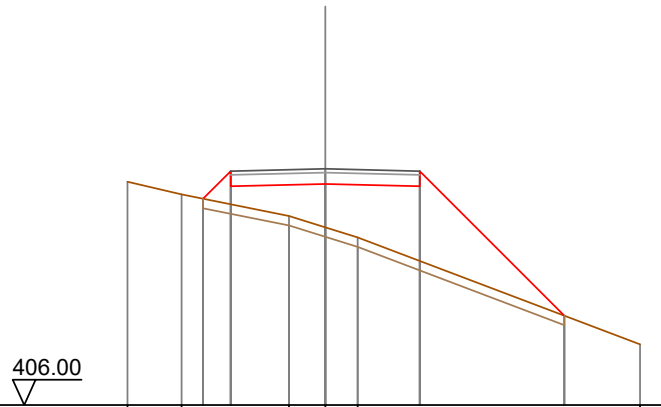

Quote Terreno	-411.91	-411.57	-411.46	-411.79	-411.00	-410.70	-410.43	-411.79	-407.61
Quote Progetto			411.46	411.79	411.85	410.70	410.43	408.36	
Parziali			0.73	2.50	2.50	3.82			
Progressiva		-3.23	-2.50	0.00	2.50	6.32			
Dislivelli		0.00	0.88	1.15	1.98	-0.00			

Sezione: 65
 Progressiva: 362.848
 Q. Progetto: 412.136

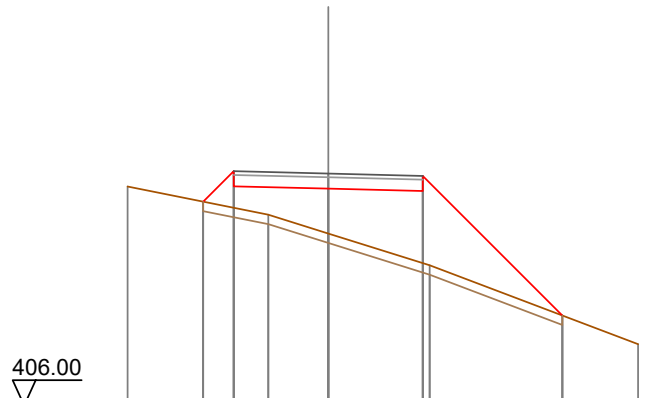

Quote Terreno	-411.79		-411.05	-410.55	-409.71		-407.62
Quote Progetto		411.39	411.80	411.74	411.67		408.38
Parziali		0.81	2.50	2.50	3.69		
Progressiva		-3.31	-2.50	0.00	2.50		6.19
Dislivelli		0.00	0.97	1.19	1.91		0.00

Sezione: 66
 Progressiva: 365.841
 Q. Progetto: 411.999

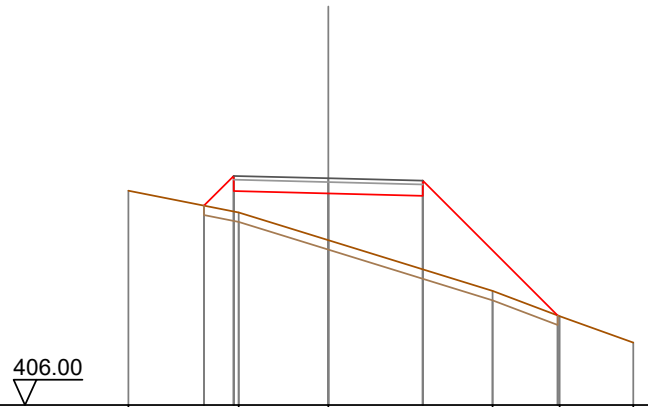

Quote Terreno	-411.67		-411.09	-410.36		-409.02	-408.35	-407.65
Quote Progetto		411.28	411.66	411.60	411.54		408.37	
Parziali		0.79	2.50	2.50	3.57			
Progressiva		-3.29	-2.50	0.00	2.50		6.07	
Dislivelli		0.00	0.94	1.24	1.95		0.00	

Sezione: 67
 Progressiva: 368.835
 Q. Progetto: 411.844

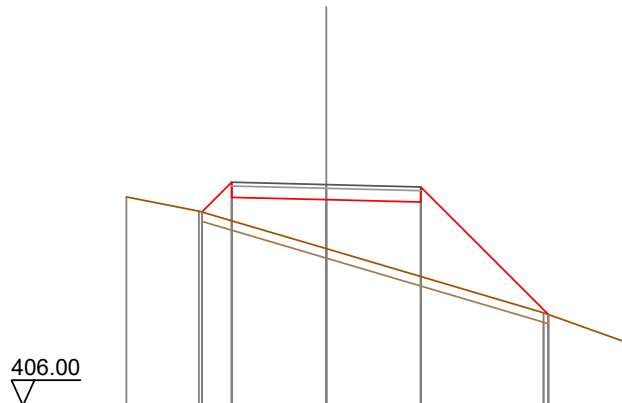

Quote Terreno	-411.52	-411.14	-411.15	-410.15	-408.45	-407.69
Quote Progetto		411.12	411.51	411.44	411.38	408.41
Parziali		0.79	2.50	2.50	3.37	
Progressiva		-3.29	-2.50	0.00	2.50	5.87
Dislivelli		-0.00	1.02	1.29	1.97	0.00

Sezione: 68
 Progressiva: 369.721
 Q. Progetto: 411.795



Quote Terreno	-411.45	-411.40	-411.16	-410.37	-410.06	-408.28	-407.68
Quote Progetto			411.05	411.46	411.39	411.33	408.37
Parziali			0.81	2.50	2.50	3.36	
Progressiva			-3.31	-2.50	0.00	2.50	5.86
Dislivelli			0.00	1.06	1.34	1.99	0.00

Sezione: 69
 Progressiva: 370.000
 Q. Progetto: 411.779

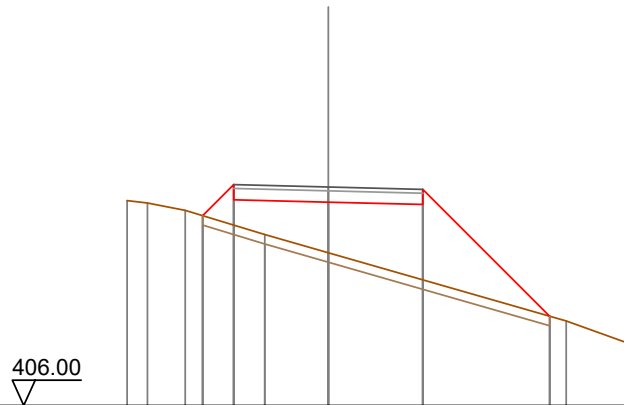

Quote Terreno	-411.42	-411.36	-411.16	-410.52	-410.04	-408.23	-407.67
Quote Progetto			411.02	411.44	411.38	411.32	408.36
Parziali			0.82	2.50	2.50	3.36	
Progressiva			-3.32	-2.50	0.00	2.50	5.86
Dislivelli			0.00	1.07	1.34	1.99	0.00

Sezione: 70
 Progressiva: 377.714
 Q. Progetto: 411.438

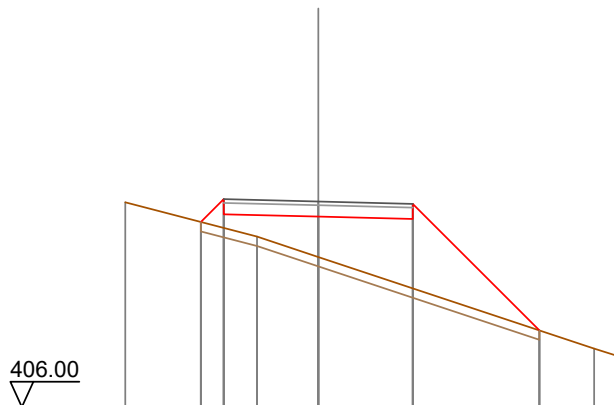

Quote Terreno	-411.42	-410.90	-411.10	-410.51	-409.97	-407.55	-407.37
Quote Progetto		410.90	411.10	411.04	410.98	408.03	
Parziali		0.61	2.50	2.50	3.35		
Progressiva		-3.11	-2.50	0.00	2.50	5.85	
Dislivelli		-0.00	0.76	1.07	1.84	0.00	

Sezione: 71
 Progressiva: 380.000
 Q. Progetto: 411.354



Quote Terreno		411.35		410.29	410.13	409.97		410.89		408.16	407.60	407.50
Quote Progetto			410.84	411.02		410.85		410.89		408.16		
Parziali			0.58	2.50		2.50		3.13				
Progressiva			-3.08	-2.50		0.00		2.50		5.63		
Dislivelli			0.00	0.73		0.98		1.73		-0.00		

Sezione: 72
 Progressiva: 385.708
 Q. Progetto: 411.191

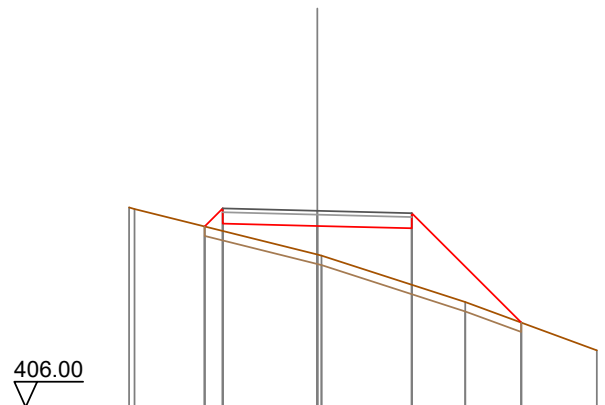

Quote Terreno		411.28	411.24		410.03	410.01		410.73		408.78		407.50
Quote Progetto				410.78	410.85		410.73		408.24			
Parziali				0.48	2.50		2.50		2.89			
Progressiva				-2.98	-2.50		0.00		2.50		5.39	
Dislivelli				0.00	0.60		0.76		1.49		-0.00	

Sezione: 73
 Progressiva: 389.758
 Q. Progetto: 411.115

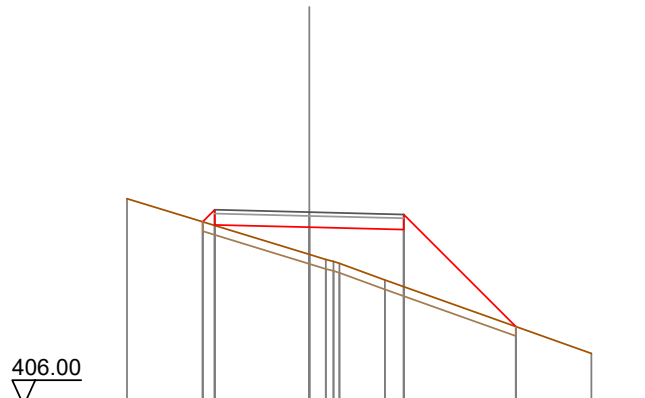

Quote Terreno	-411.47		410.00	409.76	409.32		-407.38
Quote Progetto		410.86	410.72	410.65		408.09	
Parziali		0.39	2.50	2.50	2.96		
Progressiva		-2.82	0.00	2.50		5.46	
Dislivelli		0.00	0.72	1.51		-0.00	

Sezione: 74
 Progressiva: 390.000
 Q. Progetto: 411.112



Quote Terreno	-411.48		410.01	409.78			-407.40
Quote Progetto		410.87	410.71	410.65		408.11	
Parziali		0.39	2.50	2.50	2.94		
Progressiva		-2.80	0.00	2.50		5.44	
Dislivelli		0.00	0.70	1.50		0.00	

Sezione: 75
 Progressiva: 397.451
 Q. Progetto: 411.061

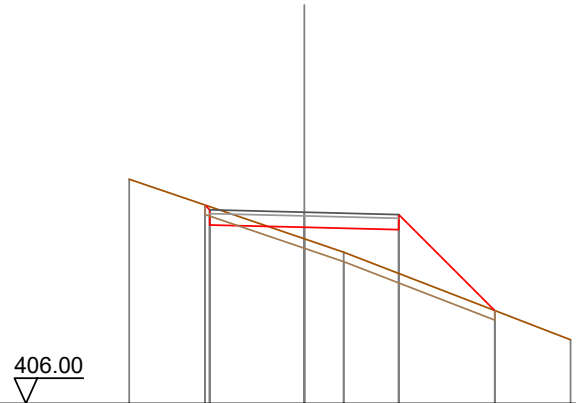

Quote Terreno	-411.93		410.36	410.00		-407.68
Quote Progetto		411.25 410.72	410.66	410.60		408.46
Parziali			2.50	2.50	2.54	
Progressiva		-2.63 -2.50	0.00	2.50	5.04	
Dislivelli		-0.00 -0.09	0.30	1.16	-0.00	

Sezione: 76
 Progressiva: 400.000
 Q. Progetto: 411.069

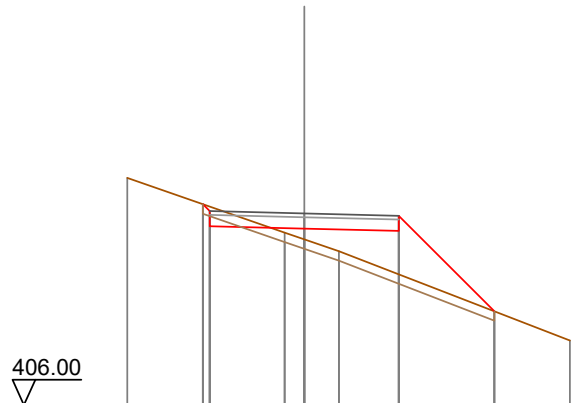

Quote Terreno	-412.01		410.56	410.38	410.07	-407.71
Quote Progetto		411.31 410.73	410.67	410.61		408.48
Parziali			2.50	2.50	2.52	
Progressiva		-2.68 -2.50	0.00	2.50	5.02	
Dislivelli		0.00 -0.12	0.29	1.15	0.00	

Sezione: 77
 Progressiva: 405.144
 Q. Progetto: 411.125

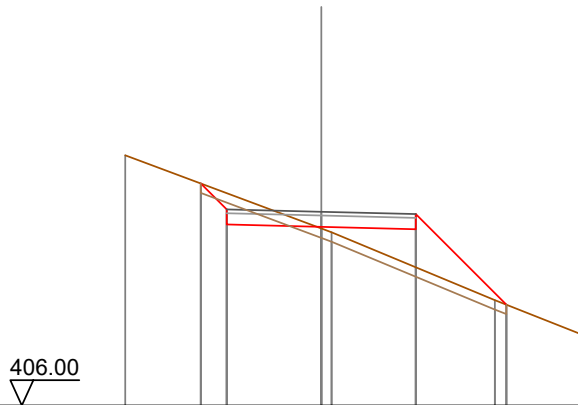

Quote Terreno		-412.62			410.68	410.58			-408.79	-407.88
Quote Progetto			411.87	410.79	410.72		410.66		408.67	
Parziali			0.69	2.50	2.50		2.39			
Progressiva			-3.19	-2.50	0.00		2.50		4.89	
Dislivelli			0.00	-0.43	0.04		1.01		-0.00	

Sezione: 78
 Progressiva: 416.863
 Q. Progetto: 411.450

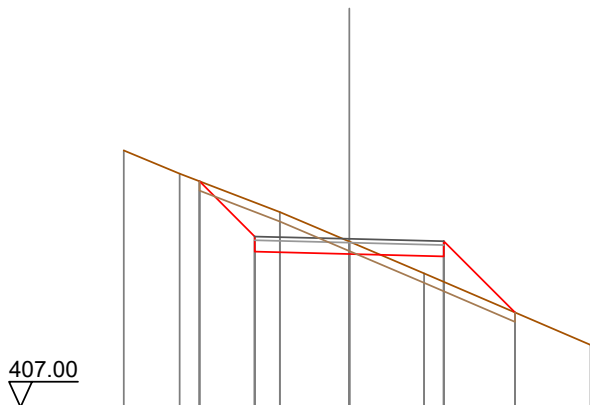

Quote Terreno		-413.79	-413.17	-412.16	-411.38	-410.54			-408.64
Quote Progetto			412.97	411.11	411.05	410.99		409.50	
Parziali			1.46	2.50	2.50	1.88			
Progressiva			-3.96	-2.50	0.00	2.50		4.38	
Dislivelli			0.00	-0.90	-0.33	0.67		-0.00	

Sezione: 79
 Progressiva: 417.376
 Q. Progetto: 411.470

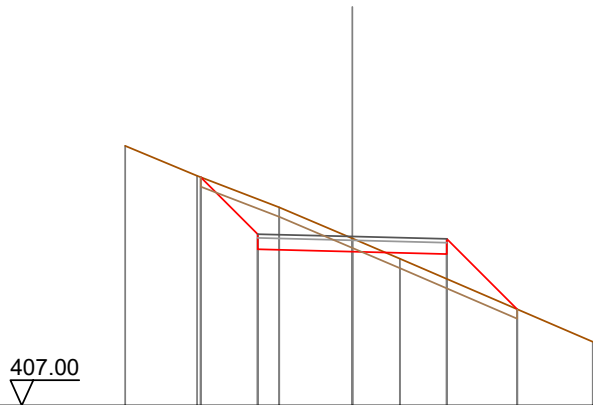

Quote Terreno	-413.87	-413.08	-412.24	-411.42	-410.88	-408.69
Quote Progetto		413.04	411.13	411.07	411.01	409.55
Parziali		1.51	2.50	2.50	1.86	
Progressiva		-4.01	-2.50	0.00	2.50	4.36
Dislivelli		-0.00	-0.93	-0.35	0.66	0.00

Sezione: 80
 Progressiva: 417.890
 Q. Progetto: 411.491

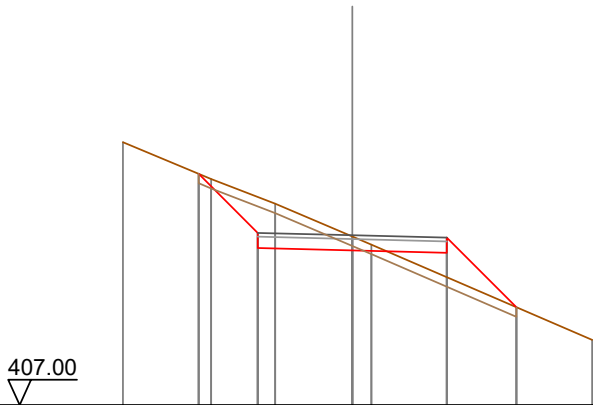

Quote Terreno	-413.95	-412.98	-412.33	-411.46	-411.24	-408.72
Quote Progetto		413.12	411.15	411.09	411.03	409.59
Parziali		1.56	2.50	2.50	1.84	
Progressiva		-4.06	-2.50	0.00	2.50	4.34
Dislivelli		0.00	-0.95	-0.37	0.65	0.00

Sezione: 81
 Progressiva: 420.000
 Q. Progetto: 411.583

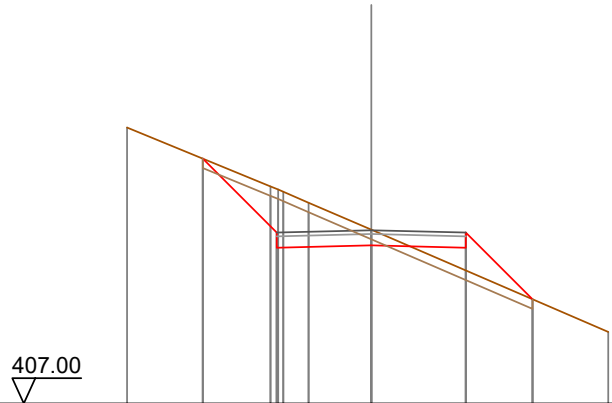

Quote Terreno	-414.30		412.74	412.60	412.31	411.60		-408.89
Quote Progetto		413.48	411.12			411.18	411.12	409.75
Parziali			1.96	2.50		2.50	1.77	
Progressiva		-4.46	-2.50			0.00	2.50	4.27
Dislivelli		0.00	-1.16			-0.41	0.60	-0.00

Sezione: 82
 Progressiva: 437.152
 Q. Progetto: 412.662

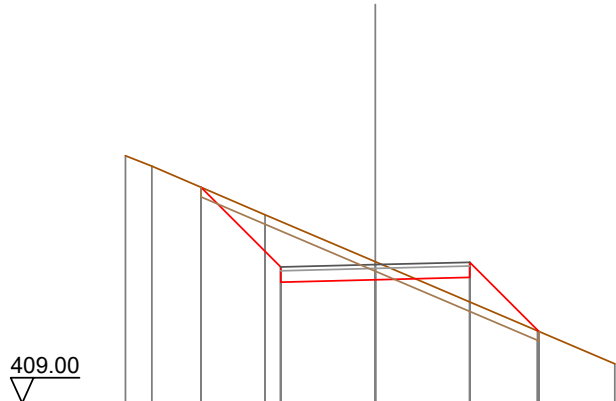

Quote Terreno	-415.54	-415.27	-413.98	-412.74		-410.91	-410.04
Quote Progetto		414.71	412.20	412.26	412.32	410.89	
Parziali			2.11	2.50	2.50	1.83	
Progressiva		-4.61	-2.50	0.00	2.50	4.33	
Dislivelli		0.00	-1.20	-0.48	0.65	0.00	

Sezione: 83
 Progressiva: 440.000
 Q. Progetto: 412.883

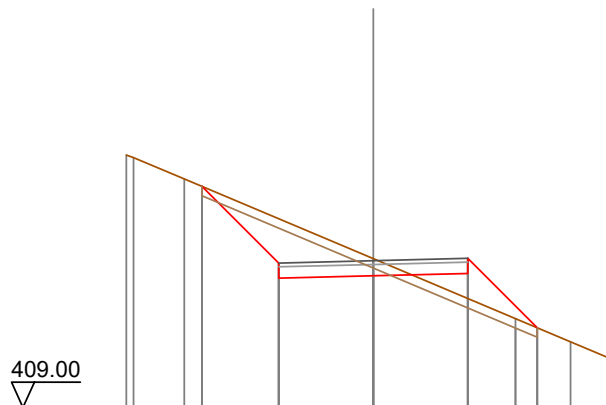

Quote Terreno	415.68	415.61	415.05	412.94	411.35	410.74	410.26
Quote Progetto		414.85	412.42	412.48	412.55	411.11	
Parziali			2.03	2.50	2.50	1.84	
Progressiva		-4.53	-2.50	0.00	2.50	4.34	
Dislivelli		0.00	-1.17	-0.46	0.66	-0.00	

Sezione: 84
 Progressiva: 441.353
 Q. Progetto: 412.988

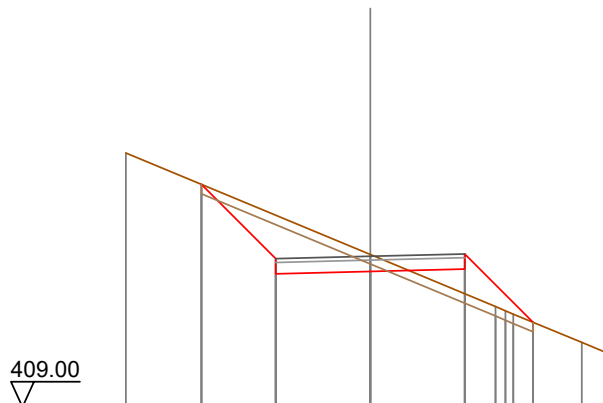

Quote Terreno	415.72	414.89	412.53	413.04	411.66	411.46	410.71	410.41
Quote Progetto		414.89	412.53	412.59	412.65	411.24		
Parziali			1.96	2.50	2.50	1.81		
Progressiva		-4.46	-2.50	0.00	2.50	4.31		
Dislivelli		-0.00	-1.15	-0.45	0.65	-0.00		

Sezione: 85
 Progressiva: 445.555
 Q. Progetto: 413.289

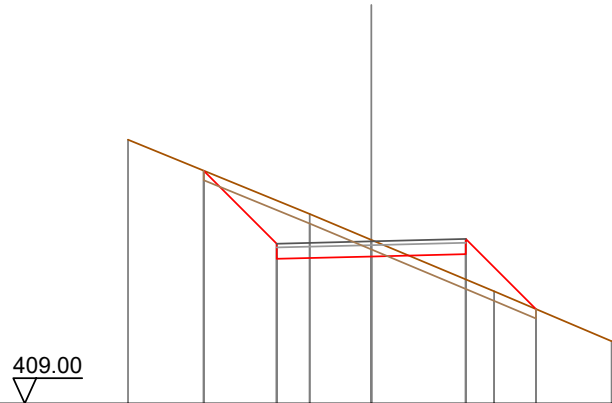

Quote Terreno		-415.98			-414.01	-413.33		-411.97	-410.65
Quote Progetto			415.16	412.83		412.89	412.95	411.50	
Parziali			1.93	2.50		2.50	1.85		
Progressiva			-4.43	-2.50		0.00	2.50	4.35	
Dislivelli			0.00	-1.14		-0.44	0.67	-0.00	

Sezione: 86
 Progressiva: 449.588
 Q. Progetto: 413.545

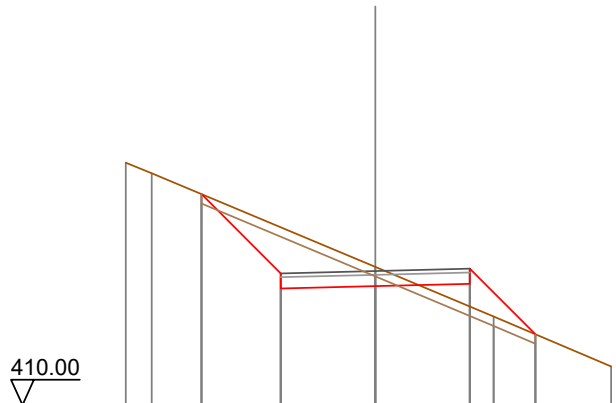

Quote Terreno		-416.41	-416.13			-413.65		-412.34	-411.02
Quote Progetto			415.58	413.08		413.15	413.21	411.87	
Parziali			2.10	2.50		2.50	1.74		
Progressiva			-4.60	-2.50		0.00	2.50	4.24	
Dislivelli			0.00	-1.22		-0.51	0.60	-0.00	

Sezione: 87
 Progressiva: 450.000
 Q. Progetto: 413.570

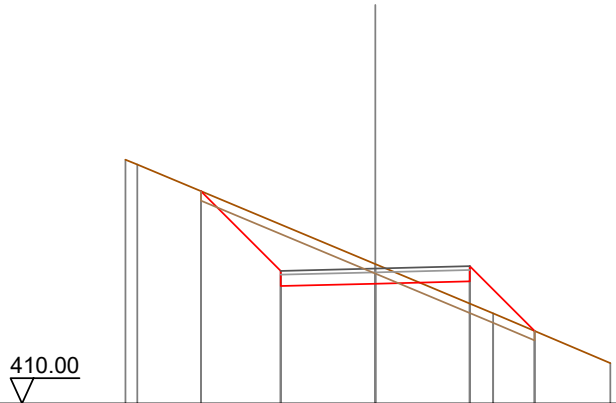

Quote Terreno		416.45	416.32		413.69	413.38	411.07
Quote Progetto			415.62	413.11	413.17	413.23	411.92
Parziali			2.11	2.50	2.50	1.71	
Progressiva			-4.61	-2.50	0.00	2.50	4.21
Dislivelli			-0.00	-1.23	-0.52	0.59	0.00

Sezione: 88
 Progressiva: 457.992
 Q. Progetto: 413.974

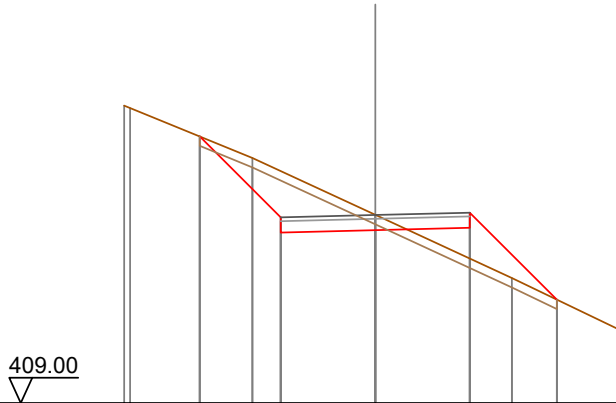

Quote Terreno		416.87	416.81	415.48	413.98	412.31	410.77
Quote Progetto			416.05	413.51	413.57	413.64	411.74
Parziali			2.14	2.50	2.50	2.30	
Progressiva			-4.64	-2.50	0.00	2.50	4.80
Dislivelli			0.00	-1.23	-0.41	0.81	0.00

Sezione: 89
 Progressiva: 460.000
 Q. Progetto: 414.055

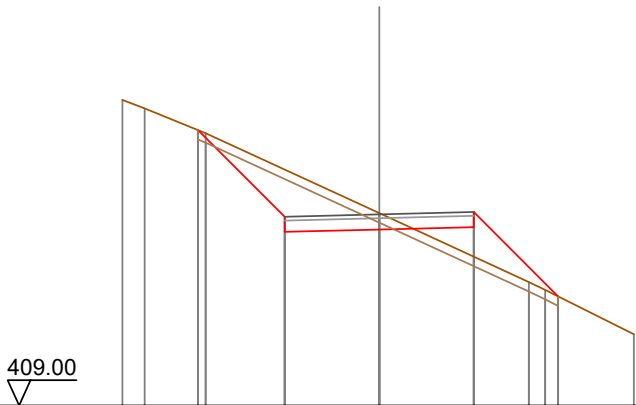

Quote Terreno	-417.08	-416.86	-416.20	-413.59	-414.09	-413.72	-412.26	-412.06	-410.88
Quote Progetto			416.29	413.59	413.66	413.72	411.89		
Parziali			2.29	2.50	2.50	2.23			
Progressiva			-4.79	-2.50	0.00	2.50	4.73		
Dislivelli			0.00	-1.25	-0.43	0.78	-0.00		

Sezione: 90
 Progressiva: 466.395
 Q. Progetto: 414.261

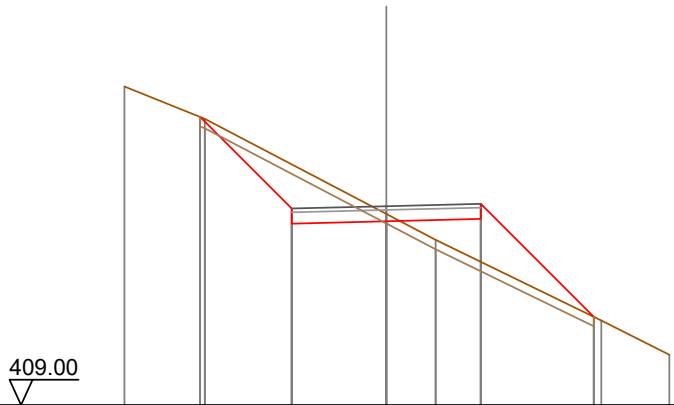

Quote Terreno	-417.43	-416.62	-416.57	-413.80	-414.06	-413.37	-411.24	-410.33
Quote Progetto			416.62	413.80	413.86	413.92	411.34	
Parziali			2.43	2.50	2.50	2.99		
Progressiva			-4.93	-2.50	0.00	2.50	5.49	
Dislivelli			-0.00	-1.17	-0.19	1.13	-0.00	

Sezione: 91
 Progressiva: 470.428
 Q. Progetto: 414.359

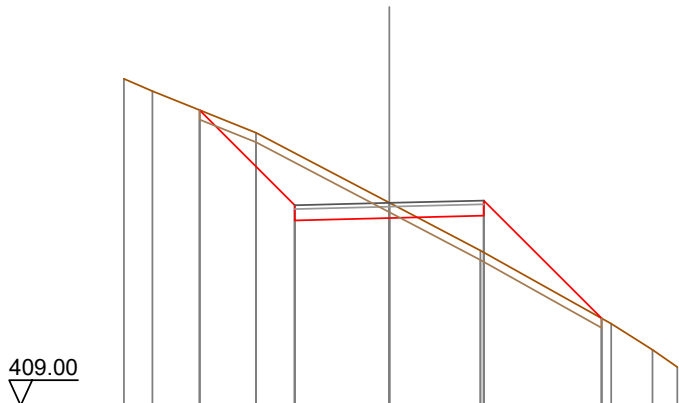

Quote Terreno		-417.64	-417.31	-416.21	-414.36	-413.10	-411.16	-410.48	-410.02
Quote Progetto			416.81	413.90	413.96	414.02	411.31		
Parziali				2.52	2.50	2.50	3.12		
Progressiva			-5.02	-2.50	0.00	2.50	5.62		
Dislivelli			0.00	-1.38	-0.40	0.97	-0.00		

Sezione: 92
 Progressiva: 474.630
 Q. Progetto: 414.462

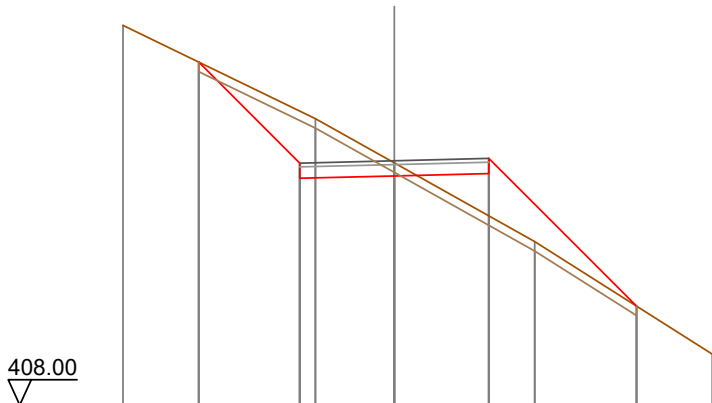

Quote Terreno		-418.04	-415.57	-414.41	-412.32	-409.35
Quote Progetto		417.07	414.00	414.06	414.12	410.62
Parziali			2.67	2.50	2.50	3.91
Progressiva		-5.17	-2.50	0.00	2.50	6.41
Dislivelli		0.00	-1.38	-0.34	1.12	0.00

Sezione: 93
 Progressiva: 478.832
 Q. Progetto: 414.564

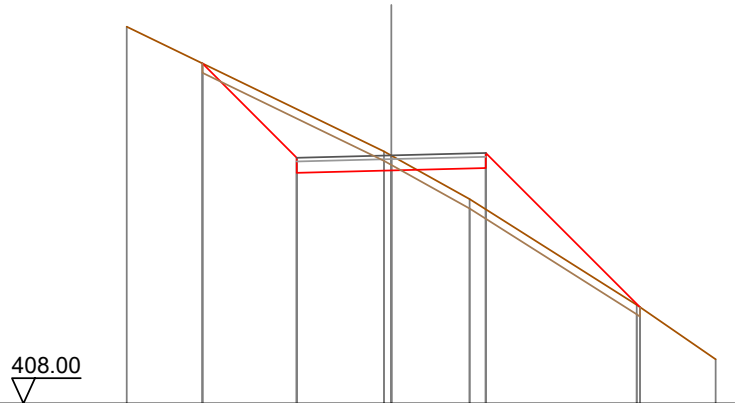

Quote Terreno		-417.97			414.67	414.56	-413.41		410.61	-409.17
Quote Progetto			417.00		414.10		414.16	414.23		410.55
Parziali				2.49		2.50		2.50		4.08
Progressiva			-4.99		-2.50		0.00	2.50		6.58
Dislivelli			0.00		-1.29		-0.40	1.09		0.00

Sezione: 94
 Progressiva: 480.000
 Q. Progetto: 414.592

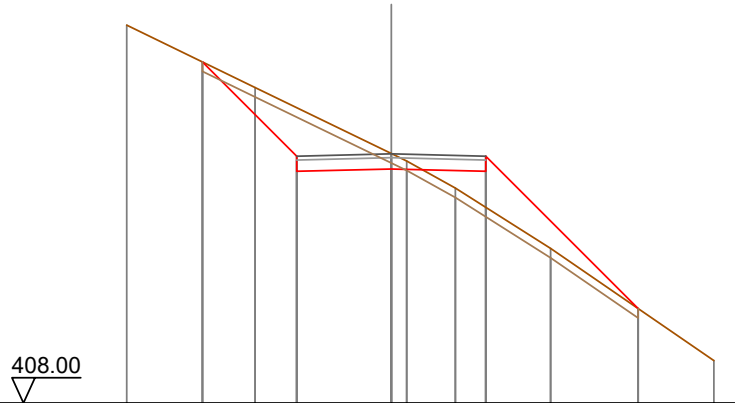

Quote Terreno		-418.00			414.60	414.40	-413.69		412.09	-409.12
Quote Progetto			417.02		414.13		414.13		410.50	
Parziali				2.49		2.50		2.50		4.03
Progressiva			-4.99		-2.50		0.00	2.50		6.53
Dislivelli			0.00		-1.28		-0.41	0.95		-0.00

Sezione: 95
 Progressiva: 500.000
 Q. Progetto: 415.079

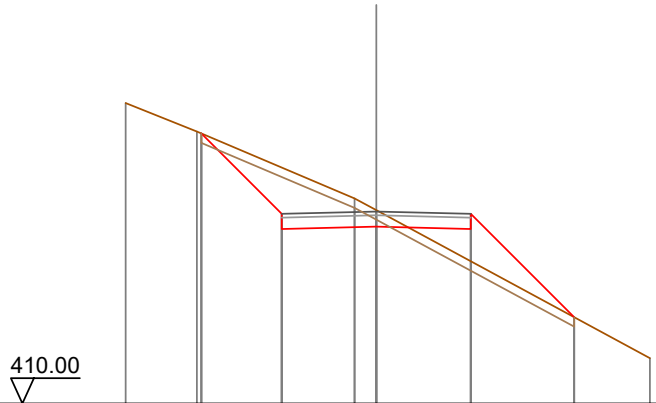

Quote Terreno	-417.95	-417.19	-415.42	-415.11	-414.62	-412.28	-411.20
Quote Progetto		417.14	414.62	414.68	414.62	412.28	
Parziali		2.13	2.50	2.50	2.74		
Progressiva		-4.63	-2.50	0.00	2.50	5.24	
Dislivelli		0.00	-1.22	-0.43	0.86	0.00	

Sezione: 96
 Progressiva: 504.738
 Q. Progetto: 415.194

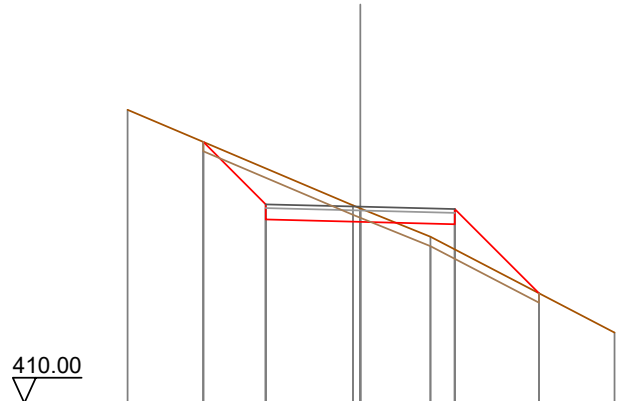

Quote Terreno	-417.76	-415.23	-415.15	-414.40	-411.86	
Quote Progetto		416.91	414.86	414.79	414.73	412.91
Parziali		1.65	2.50	2.50	2.22	
Progressiva		-4.15	-2.50	0.00	2.50	4.72
Dislivelli		0.00	-0.95	-0.36	0.67	-0.00

Sezione: 97
 Progressiva: 508.903
 Q. Progetto: 415.295

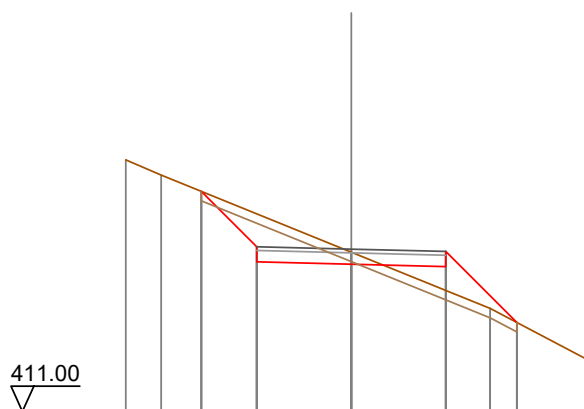

Quote Terreno	-417.65	-417.25		415.21		-413.73	-412.30
Quote Progetto			416.82	414.96	414.90	414.83	413.95
Parziali			1.46	2.50	2.50	1.88	
Progressiva		-3.96	-2.50	0.00	2.50	4.38	
Dislivelli		-0.00	-0.87	-0.32	0.63	0.00	

Sezione: 98
 Progressiva: 510.000
 Q. Progetto: 415.322

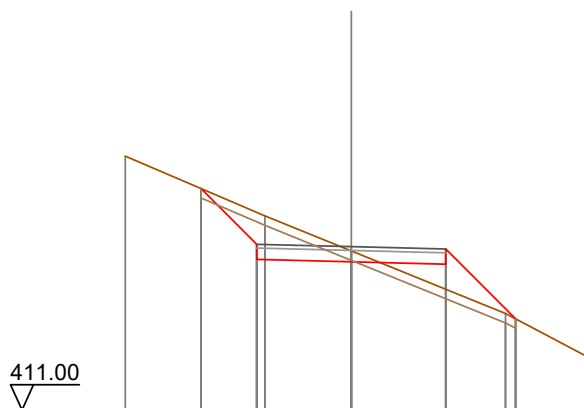

Quote Terreno	-417.72		416.13	415.21		413.56	-412.36
Quote Progetto		416.86	414.98	414.92	414.86	413.41	
Parziali		1.47	2.50	2.50	1.85		
Progressiva		-3.97	-2.50	0.00	2.50	4.35	
Dislivelli		-0.00	-0.84	-0.29	0.66	0.00	

Sezione: 99
 Progressiva: 513.068
 Q. Progetto: 415.397

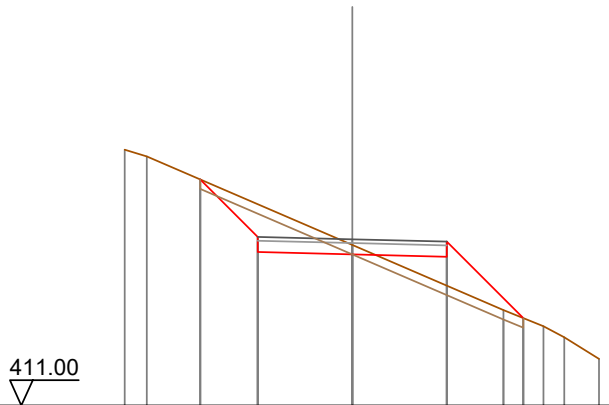

Quote Terreno	-417.77	-417.59		415.25		-413.52	-413.10	-412.81	-412.23
Quote Progetto			416.98	415.06	415.00	414.93	413.31		
Parziali			1.52	2.50	2.50	2.02			
Progressiva		-4.02	-2.50	0.00	2.50	4.52			
Dislivelli		0.00	-0.86	-0.25	0.77	0.00			

Sezione: 100
 Progressiva: 520.000
 Q. Progetto: 415.565

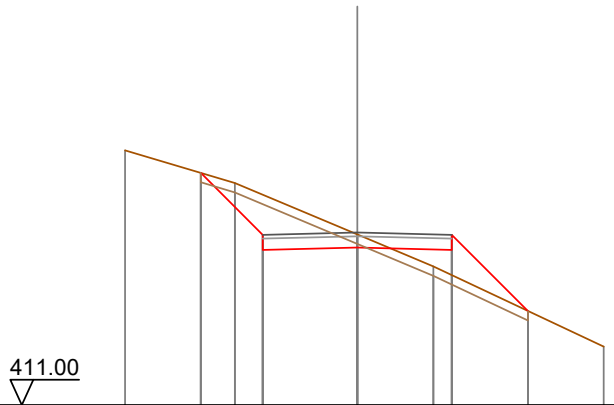

Quote Terreno	-417.74		-416.87		-415.51		-414.67		-412.55
Quote Progetto		417.14	415.10	415.17	415.10	413.49			
Parziali		1.64	2.50	2.50	2.01				
Progressiva		-4.14	-2.50	0.00	2.50	4.51			
Dislivelli		0.00	-1.06	-0.35	0.67	-0.00			

Sezione: 101
 Progressiva: 521.301
 Q. Progetto: 415.597

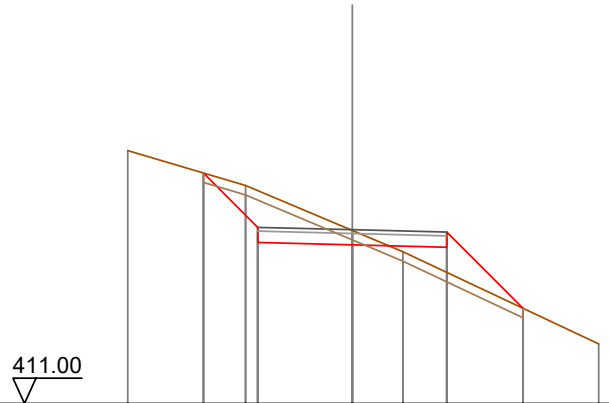

Quote Terreno		417.69		416.77		415.58		415.02		413.52		412.57
Quote Progetto			417.10		415.26		415.20		415.13		413.52	
Parziali				1.44		2.50		2.50		2.02		
Progressiva			-3.94		-2.50		0.00		2.50		4.52	
Dislivelli			-0.00		-0.97		-0.38		0.67		-0.00	

Sezione: 102
 Progressiva: 525.466
 Q. Progetto: 415.698

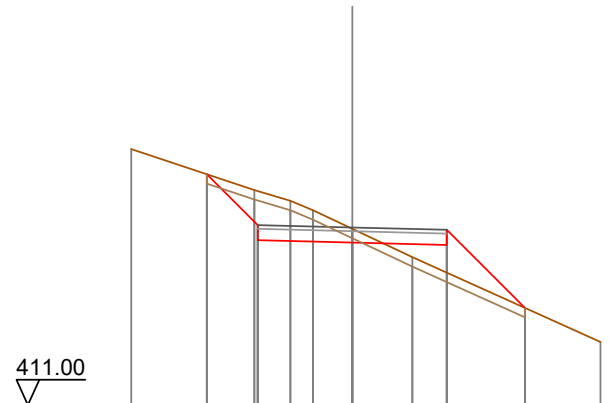

Quote Terreno		417.77		416.69		415.66		414.91		413.57		412.67
Quote Progetto			417.11		415.36		415.30		415.24		413.57	
Parziali				1.34		2.50		2.50		2.06		
Progressiva			-3.94		-2.50		0.00		2.50		4.56	
Dislivelli			0.00		-0.90		-0.36		0.73		0.00	

Sezione: 103
 Progressiva: 529.630
 Q. Progetto: 415.799

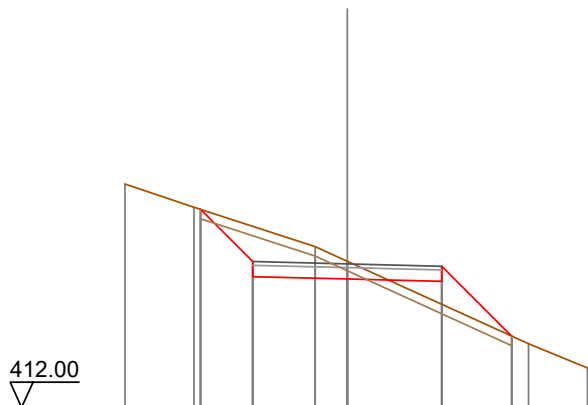

Quote Terreno	-417.91	-417.30	-416.25	-415.87	-413.69	-413.05
Quote Progetto		417.24	415.46	415.40	415.34	413.89
Parziali		1.38	2.50	2.50	1.85	
Progressiva		-3.88	-2.50	0.00	2.50	4.35
Dislivelli		0.00	-0.93	-0.47	0.61	-0.00

Sezione: 104
 Progressiva: 540.000
 Q. Progetto: 415.927

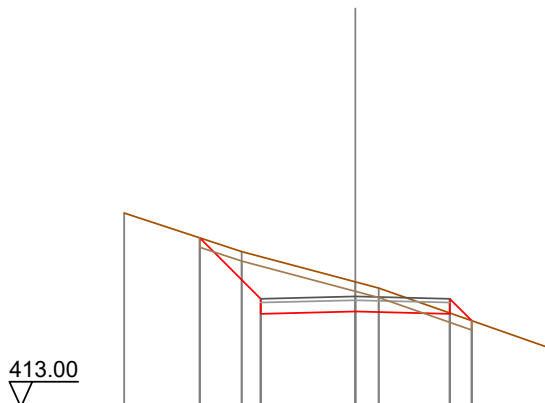

Quote Terreno	-418.13	-417.11	-416.31	-416.15	-414.59	
Quote Progetto		417.48	415.46	415.53	415.46	415.29
Parziali		1.61	2.50	2.50	0.58	
Progressiva		-4.11	-2.50	0.00	2.50	3.08
Dislivelli		0.00	-1.11	-0.78	-0.02	-0.00

Sezione: 105
 Progressiva: 552.574
 Q. Progetto: 415.794

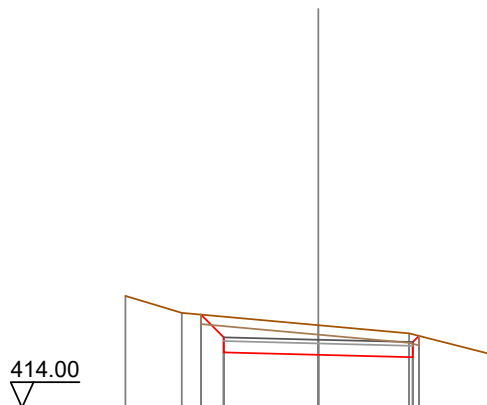

Quote Terreno	-416.95	-416.50		416.18	415.96	-415.38
Quote Progetto		416.46	415.46	415.39	415.33	415.89
Parziali		0.60	2.50	2.50		
Progressiva		-3.10	-2.50	0.00	2.50	2.66
Dislivelli		0.00	-0.55	-0.78	-0.60	0.00

Sezione: 106
 Progressiva: 555.392
 Q. Progetto: 415.721

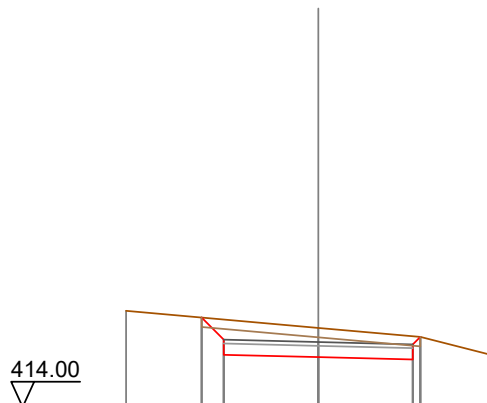

Quote Terreno	-416.54			416.09	415.86	-415.35
Quote Progetto		416.37	415.38	415.32	415.26	415.86
Parziali		0.58	2.50	2.50		
Progressiva		-3.08	-2.50	0.00	2.50	2.70
Dislivelli		0.00	-0.53	-0.77	-0.62	0.00

Sezione: 107
 Progressiva: 558.211
 Q. Progetto: 415.631

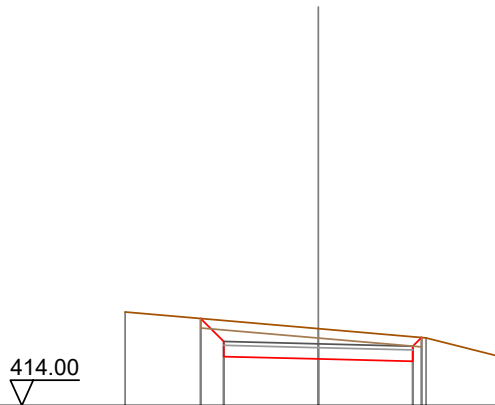

Quote Terreno	-416.47							
Quote Progetto		416.30	415.29	415.23	415.17	415.80		
Parziali		0.61	2.50	2.50				
Progressiva		-3.11	-2.50	0.00	2.50	2.73		
Dislivelli		0.00	-0.56	-0.80	-0.65	0.00		

Sezione: 108
 Progressiva: 560.000
 Q. Progetto: 415.567

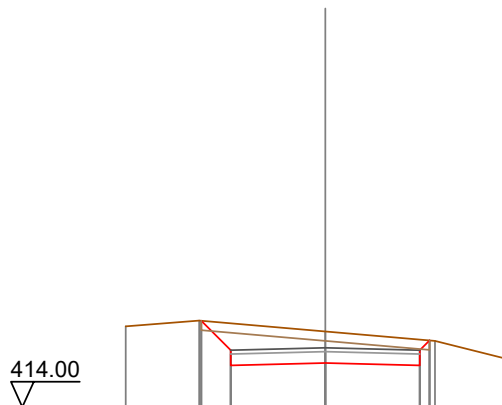

Quote Terreno	-416.13							
Quote Progetto		416.28	415.10	415.17	416.00	415.75		
Parziali		0.78	2.50	2.50				
Progressiva		-3.28	-2.50	0.00	2.50	2.76		
Dislivelli		-0.00	-0.71	-0.83	-0.68	0.00		

Sezione: 109
 Progressiva: 576.365
 Q. Progetto: 414.728

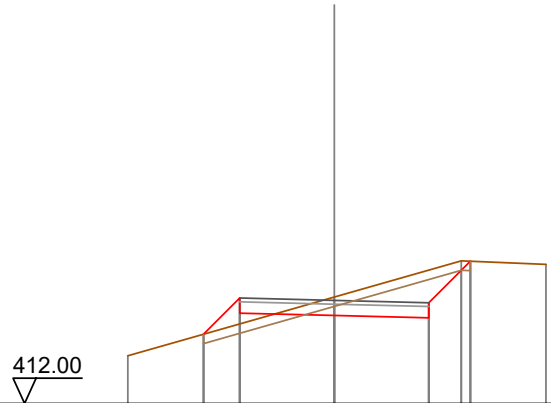

Quote Terreno	-413.26			414.82	415.77	-415.68
Quote Progetto		413.83	414.39	414.33	414.27	415.76
Parziali		0.96	2.50	2.50	1.10	
Progressiva		-3.46	-2.50	0.00	2.50	3.60
Dislivelli		-0.00	0.68	-0.49	-1.26	-0.00

Sezione: 110
 Progressiva: 576.882
 Q. Progetto: 414.699

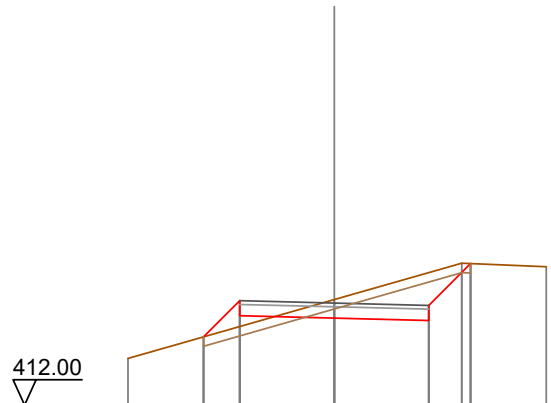

Quote Terreno	-413.23			414.79	415.75	-415.66
Quote Progetto		413.80	414.36	414.30	414.24	415.74
Parziali		0.96	2.50	2.50	1.11	
Progressiva		-3.46	-2.50	0.00	2.50	3.61
Dislivelli		-0.00	0.68	-0.49	-1.27	0.00

Sezione: 111
 Progressiva: 577.399
 Q. Progetto: 414.672

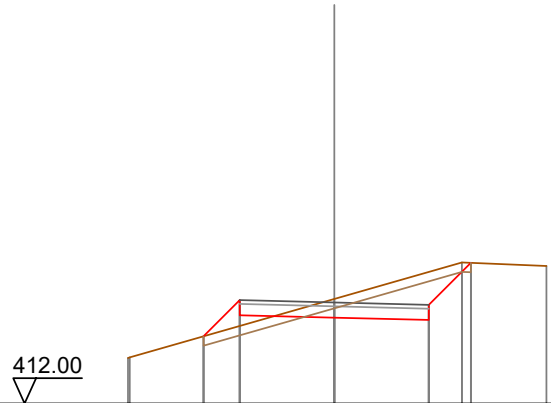

Quote Terreno		413.21	413.22							
Quote Progetto				413.78	414.33		414.27	414.77	415.73	415.64
Parziali				0.96	2.50		2.50	1.11		
Progressiva				-3.46	-2.50		0.00	2.50	3.61	
Dislivelli				-0.00	0.68		-0.49	-1.27	0.00	

Sezione: 112
 Progressiva: 580.000
 Q. Progetto: 414.540

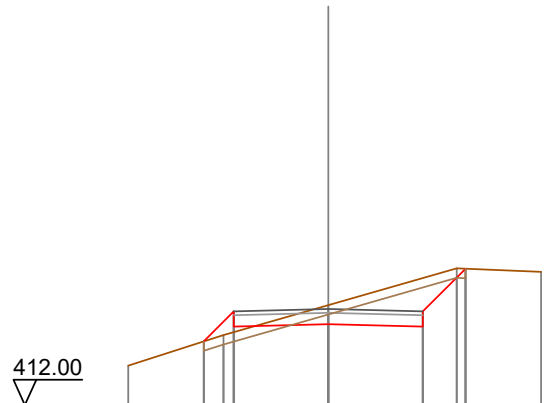

Quote Terreno		413.05							
Quote Progetto			413.69	413.85		414.14	414.65	415.62	415.52
Parziali			0.79	2.50		2.50	1.13		
Progressiva			-3.29	-2.50		0.00	2.50	3.63	
Dislivelli			-0.00	0.55		-0.51	-1.28	-0.00	

Sezione: 113
 Progressiva: 599.944
 Q. Progetto: 413.963

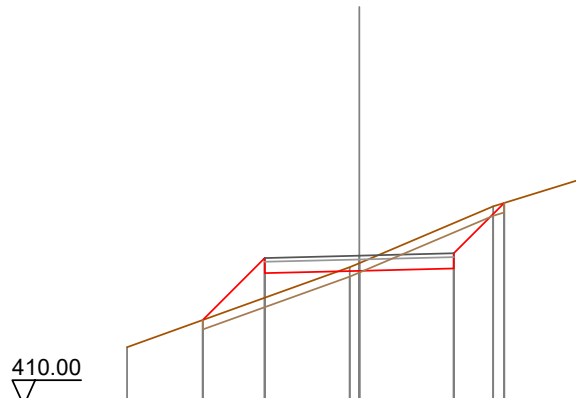

Quote Terreno	-411.54			413.66					
Quote Progetto		412.26	413.50	413.56	413.77	413.63	415.36		-415.97
Parziali			1.64	2.50		2.50	1.33		
Progressiva		-4.14	-2.50	0.00		2.50	3.83		
Dislivelli		-0.00	1.05	-0.20		-1.20	0.00		

Sezione: 114
 Progressiva: 602.745
 Q. Progetto: 413.901

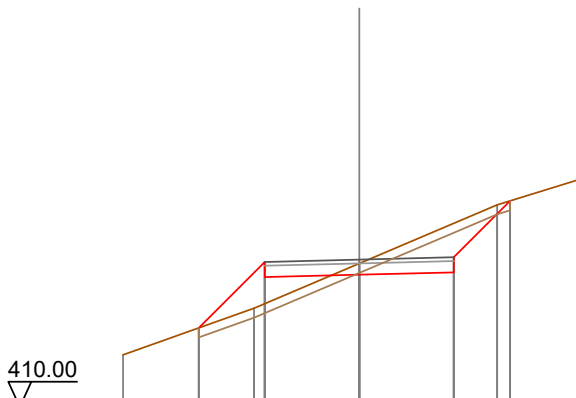

Quote Terreno	-411.38			412.61					
Quote Progetto		412.09	413.44	413.50	413.80	413.56	415.45		-416.07
Parziali			1.75	2.50		2.50	1.49		
Progressiva		-4.25	-2.50	0.00		2.50	3.99		
Dislivelli		0.00	1.10	-0.30		-1.30	0.00		

Sezione: 115
 Progressiva: 605.545
 Q. Progetto: 413.823

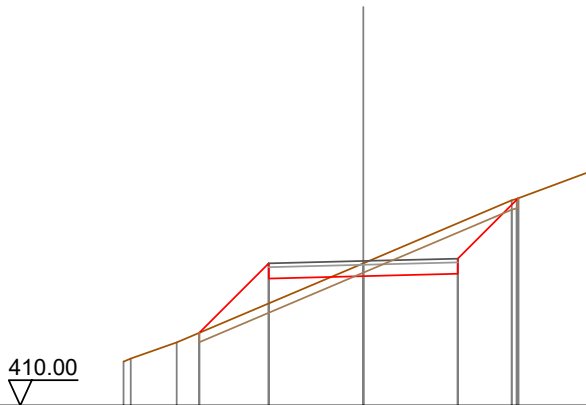

Quote Terreno		411.16	411.24	411.67		413.76	413.76	415.43	415.47	416.22
Quote Progetto				411.92	413.36	413.42	413.49	415.48		
Parziali					1.84	2.50	2.50	1.60		
Progressiva				-4.34	-2.50	0.00	2.50	4.10		
Dislivelli				-0.00	1.06	-0.34	-1.34	-0.00		

Sezione: 116
 Progressiva: 620.000
 Q. Progetto: 413.171

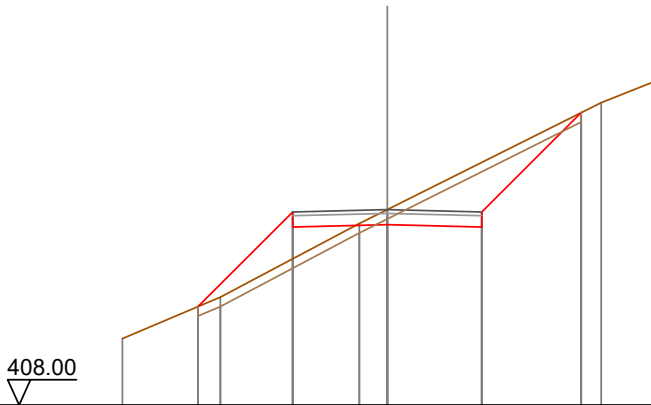

Quote Terreno		409.76	410.85	412.80	413.17	416.00	416.58
Quote Progetto			410.60	412.71	412.77	412.71	415.73
Parziali			2.50	2.50	2.50	2.63	
Progressiva			-5.00	-2.50	0.00	2.50	5.13
Dislivelli			0.00	1.24	-0.40	-1.71	0.00

Sezione: 117
 Progressiva: 627.835
 Q. Progetto: 412.698

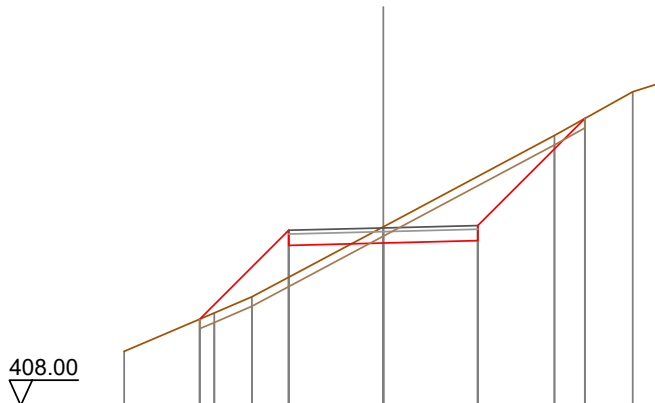

Quote Terreno		409.43							
Quote Progetto			410.28		412.24		412.30		412.36
Parziali				2.35		2.50		2.50	
Progressiva			-4.85		-2.50		0.00		2.50
Dislivelli			-0.00		1.24		-0.43		-1.70

Sezione: 118
 Progressiva: 630.000
 Q. Progetto: 412.547

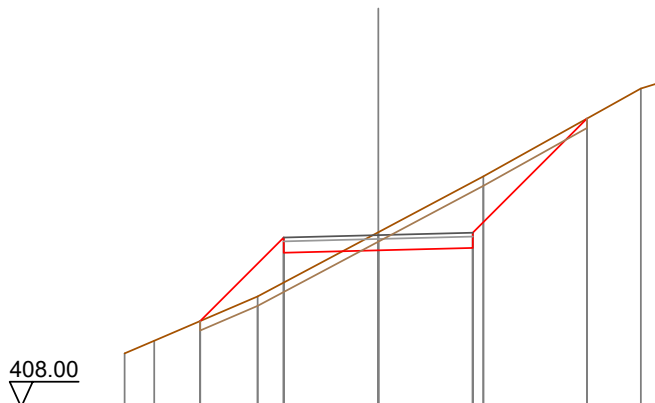

Quote Terreno		409.42							
Quote Progetto			410.27		412.08		412.15		412.21
Parziali				2.21		2.50		2.50	
Progressiva			-4.71		-2.50		0.00		2.50
Dislivelli			-0.00		1.19		-0.48		-1.74

Sezione: 119
 Progressiva: 636.766
 Q. Progetto: 412.018

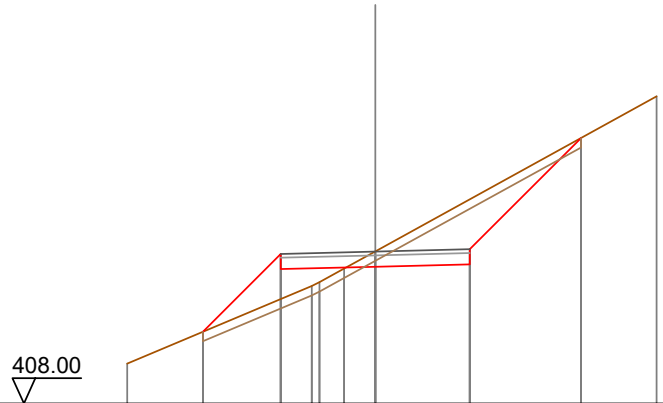

Quote Terreno	409.06		411.11	411.21	411.57	412.02		416.12
Quote Progetto		409.90	411.56		411.62	411.68		415.02
Parziali			2.06	2.50	2.50	2.50	2.94	
Progressiva		-4.56	-2.50		0.00	2.50		5.44
Dislivelli		0.00	1.19		-0.40	-1.72		0.00

Sezione: 120
 Progressiva: 640.000
 Q. Progetto: 411.752

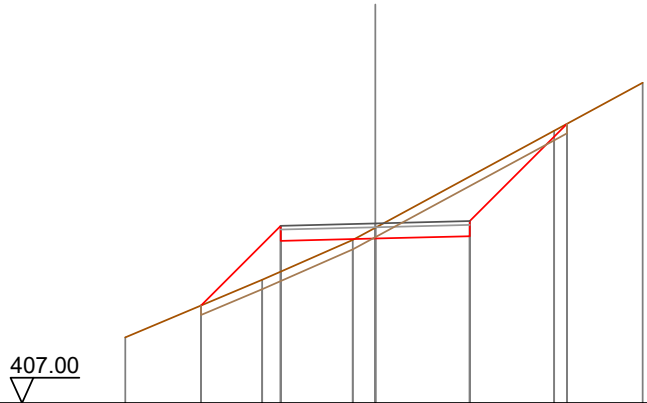

Quote Terreno	408.74		410.26	411.31	411.64		414.20	415.47
Quote Progetto		409.58	411.29	411.35	411.41		414.38	
Parziali			2.11	2.50	2.50	2.57		
Progressiva		-4.61	-2.50		0.00	2.50		5.07
Dislivelli		-0.00	1.21		-0.28	-1.58		-0.00

Sezione: 121
 Progressiva: 645.698
 Q. Progetto: 411.307

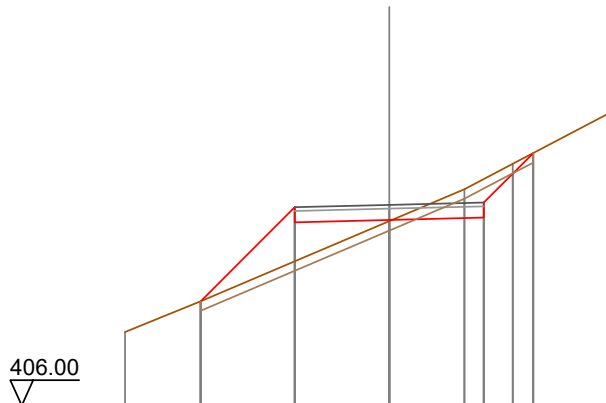

Quote Terreno		407.94	408.75		410.88	411.72	412.39	413.73
Quote Progetto			408.76	410.84	410.91	410.97	412.67	
Parziali			2.49	2.50	2.50	1.31		
Progressiva			-4.99	-2.50	0.00	2.50	3.81	
Dislivelli			-0.00	1.43	0.03	-1.02	0.00	

Sezione: 122
 Progressiva: 660.000
 Q. Progetto: 410.476

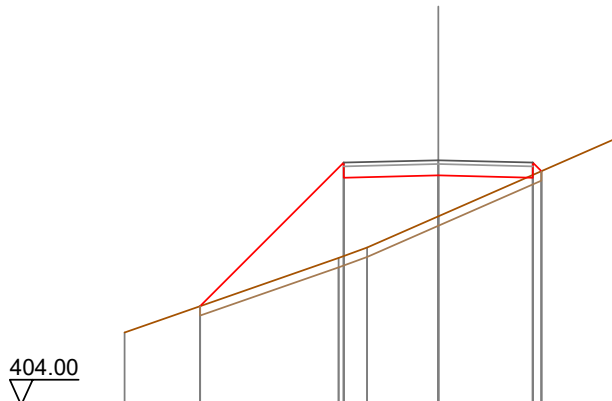

Quote Terreno		405.92		407.89	408.17	408.99		411.06
Quote Progetto			406.62	410.01	408.17	410.08	410.01	410.19
Parziali			3.80	2.50	2.50			
Progressiva			-6.30	-2.50	0.00	2.50	2.73	
Dislivelli			0.00	2.47	1.08	-0.07	0.00	

Sezione: 123
 Progressiva: 680.000
 Q. Progetto: 410.003

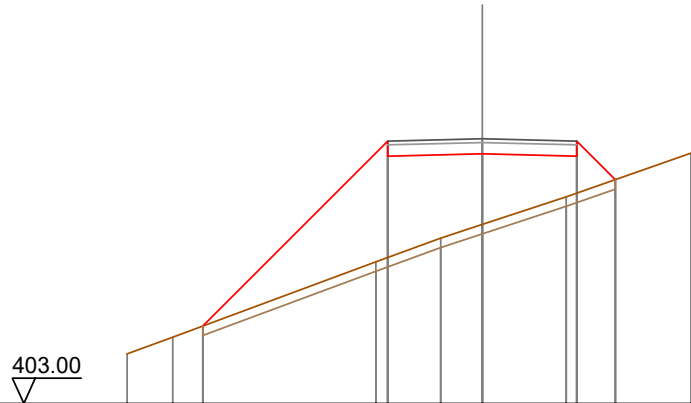

Quote Terreno		-404.31	-404.76		406.75	-407.37	407.74	408.47		-409.62
Quote Progetto			405.05		409.54		409.60	409.54	408.92	
Parziali				4.89		2.50		2.50	1.02	
Progressiva			-7.39		-2.50		0.00	2.50	3.52	
Dislivelli			-0.00		3.08		1.87	0.98	-0.00	

Sezione: 124
 Progressiva: 700.000
 Q. Progetto: 410.000

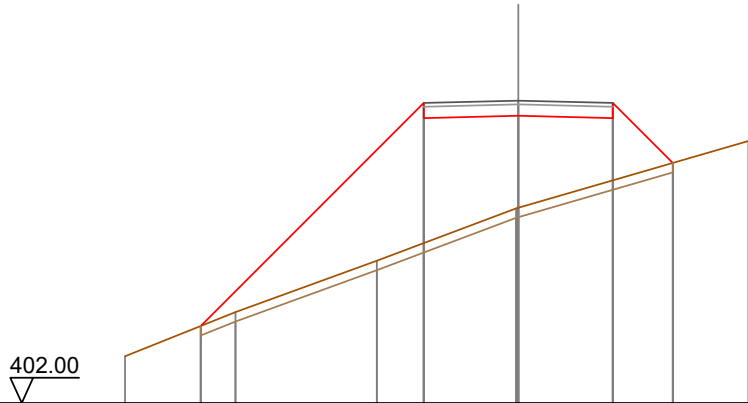

Quote Terreno		-403.24	-404.41		-405.76		407.15	407.17		-408.93
Quote Progetto			404.04		409.54		409.60	409.54	408.35	
Parziali				5.90		2.50		2.50	1.58	
Progressiva			-8.40		-2.50		0.00	2.50	4.08	
Dislivelli			0.00		3.71		2.43	1.65	-0.00	

Sezione: 125
 Progressiva: 700.294
 Q. Progetto: 410.000

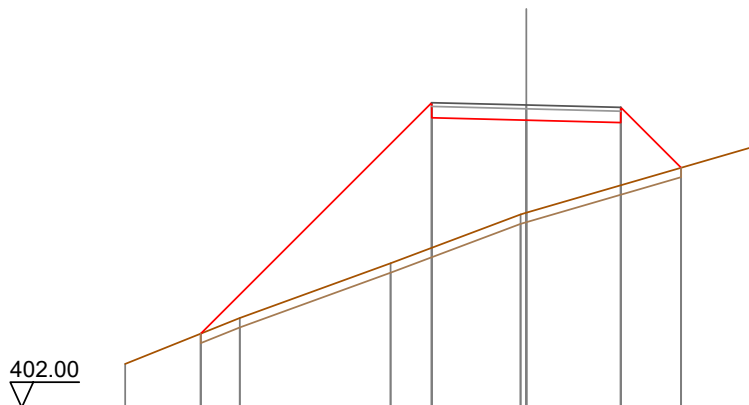

Quote Terreno	403.15	404.37	405.82	407.11	408.92
Quote Progetto	403.95	409.66	409.60	409.54	408.34
Parziali		6.11	2.50	2.50	1.60
Progressiva		-8.61	-2.50	0.00	4.10
Dislivelli		-0.00	3.84	2.45	1.66

Sezione: 126
 Progressiva: 709.592
 Q. Progetto: 410.000

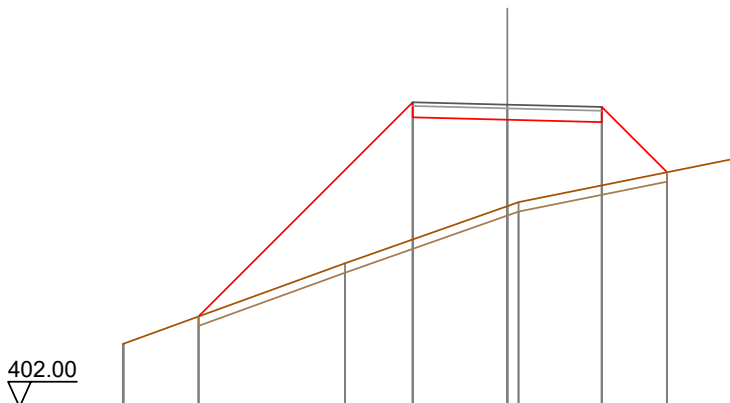

Quote Terreno	403.67	403.68	405.80	407.32	408.61
Quote Progetto	404.40	409.66	409.60	409.54	408.21
Parziali		5.67	2.50	2.50	1.73
Progressiva		-8.17	-2.50	0.00	4.23
Dislivelli		-0.00	3.63	2.28	1.67

Sezione: 127
 Progressiva: 710.000
 Q. Progetto: 410.000

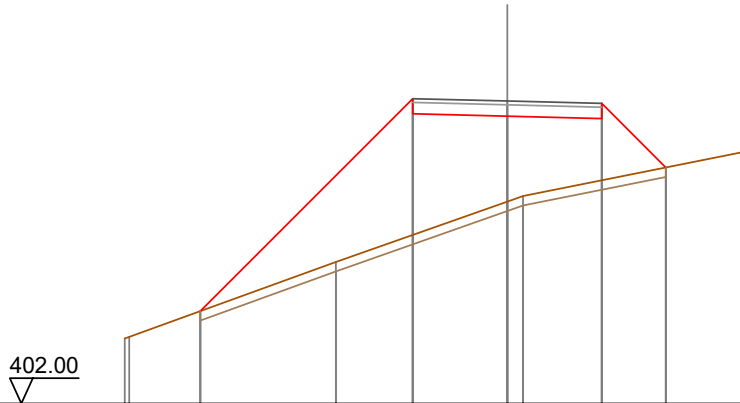

Quote Terreno		403.72	403.76		405.74		407.34	407.49		408.24	408.64
Quote Progetto				404.44			409.66	409.60		409.54	408.24
Parziali					5.62		2.50	2.50		1.69	
Progressiva				-8.12			-2.50	0.00		2.50	4.19
Dislivelli				0.00			3.60	2.26		1.63	0.00

SEZIONI TRASVERSALI
Profilo longitudinale tratto 5-6
Viabilità di impianto - Postazione aerogeneratore
VI03

Nota: Le canalette di deflusso delle acque meteoriche, non indicate nel presente elaborato, sono rappresentate graficamente nelle sezioni stradali tipo dell'elaborato "SR-VI-TC12_Piazzole aerogeneratori e strade di servizio - Particolari costruttivi", individuate planimetricamente nell'elaborato "SR-VI-TC13_Opere di regimazione acque superficiali - Planimetria generale" e quantificate nell'elaborato "SR-VI-RC6_Computo Metrico Estimativo opere civili".

DISEGNI DI RIFERIMENTO

TAVOLA	DESCRIZIONE
SR-VI-TC8.1	Piazzole e viabilità - Planimetria di progetto - Fase di cantiere
SR-VI-TC10	Profili longitudinali viabilità di impianto
SR-VI-TC12	Piazzole aerogeneratori e strade di servizio - Particolari costruttivi
SR-VI-TC13	Opere di regimazione acque superficiali - Planimetria generale

Sezione: 1
 Progressiva: 0.000
 Q. Progetto: 410.000

Scala H 1/200.00
 Scala V 1/200.00

408.00

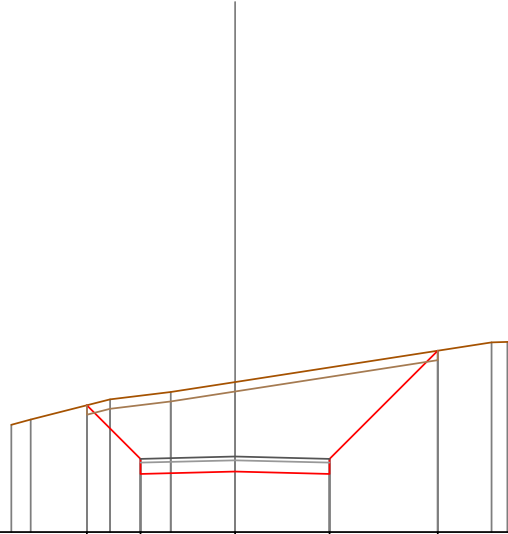

Quote	411.36	409.54	409.00	409.54	412.26
Parziali	1.42	2.50	2.50	2.86	
Sviluppata Par.	2.01	2.50	2.50	4.05	
Sviluppata	0.00	2.01	4.51	7.01	11.05
Progressiva	-3.92	-2.50	0.00	2.50	5.36
Dislivelli	0.00	-1.67	-2.37	-2.82	0.00

Sezione: 2
 Progressiva: 0.762
 Q. Progetto: 410.000

Scala H 1/200.00
 Scala V 1/200.00

408.00

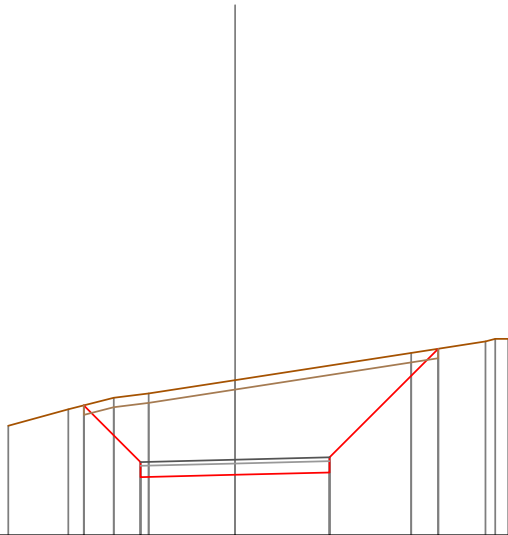

Quote	411.44	409.54	409.00	409.54	412.26
Parziali	1.50	2.50	2.50	2.87	
Sviluppata Par.	2.12	2.50	2.50	4.06	
Sviluppata	0.00	2.12	4.62	7.12	11.18
Progressiva	-4.00	-2.50	0.00	2.50	5.37
Dislivelli	0.00	-1.79	-2.50	-2.83	0.00

Sezione: 3
 Progressiva: 7.169
 Q. Progetto: 409.998

Scala H 1/200.00
 Scala V 1/200.00

408.00

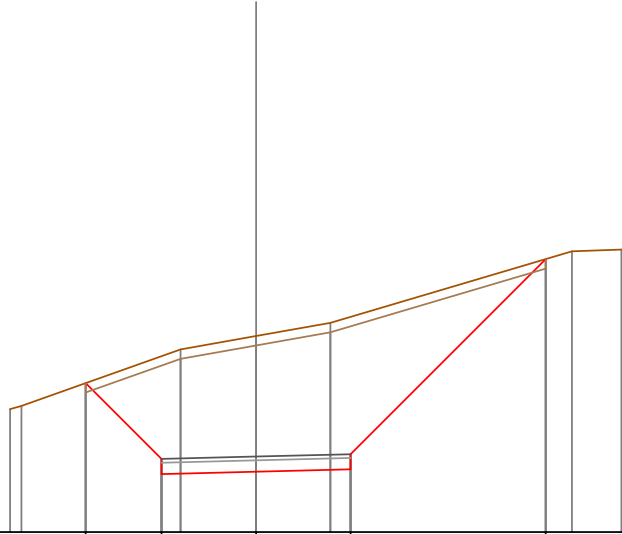

Quote	411.94	409.54	409.00	409.06	410.22
Parziali	2.01	2.50	2.50	5.16	
Sviluppata Par.	2.84	2.50	2.50	7.30	
Sviluppata	-0.00	-2.84	-5.34	-7.84	-11.14
Progressiva	-4.51	-2.50	0.00	2.50	7.66
Dislivelli	-0.00	-2.72	-3.59	-4.03	-0.00

Sezione: 4
 Progressiva: 10.000
 Q. Progetto: 409.997

Scala H 1/200.00
 Scala V 1/200.00

408.00

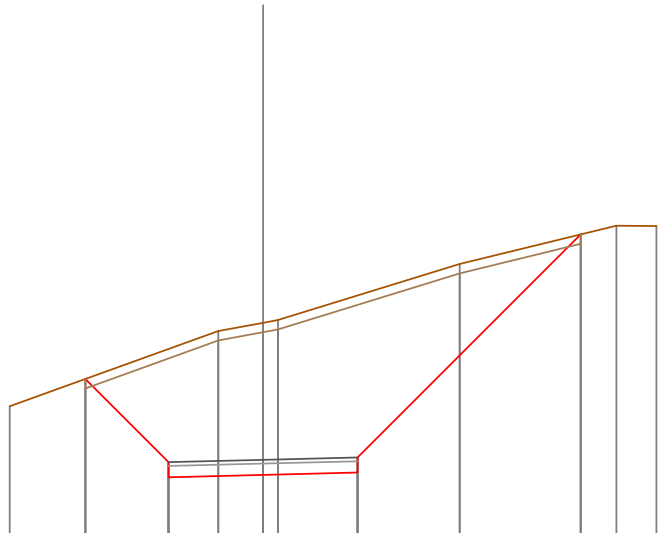

Quote	410.13	409.03	409.00	409.06	410.96
Parziali	2.20	2.50	2.50	5.90	
Sviluppata Par.	3.11	2.50	2.50	8.34	
Sviluppata	-0.00	-3.11	-5.61	-8.11	-16.46
Progressiva	-4.70	-2.50	0.00	2.50	8.40
Dislivelli	-0.00	-2.99	-4.02	-4.68	-0.00

Sezione: 5
 Progressiva: 13.576
 Q. Progetto: 409.996

Scala H 1/200.00
 Scala V 1/200.00

408.00

Quote	413.32	409.53	409.00	409.00	410.00
Parziali		2.38	2.50	2.50	5.94
Sviluppata Par.		3.37	2.50	2.50	8.40
Sviluppata	0.00	-2.50 + 3.37	0.00 + 5.87	2.50 + 8.37	16.77
Progressiva	-4.88	-2.50	0.00	2.50	8.44
Dislivelli	0.00	-3.18	-4.26	-4.86	0.00

Sezione: 6
 Progressiva: 20.000
 Q. Progetto: 409.994

Scala H 1/200.00
 Scala V 1/200.00

408.00

Quote	412.21	409.53	409.59	409.53	415.15
Parziali		2.28	2.50	2.50	5.20
Sviluppata Par.		3.23	2.50	2.50	7.36
Sviluppata	0.00	-2.50 + 3.23	0.00 + 5.73	2.50 + 8.23	15.58
Progressiva	-4.78	-2.50	0.00	2.50	7.70
Dislivelli	0.00	-2.83	-3.92	-4.63	0.00

Sezione: 7
 Progressiva: 20.350
 Q. Progetto: 409.994

Scala H 1/200.00
 Scala V 1/200.00

408.00

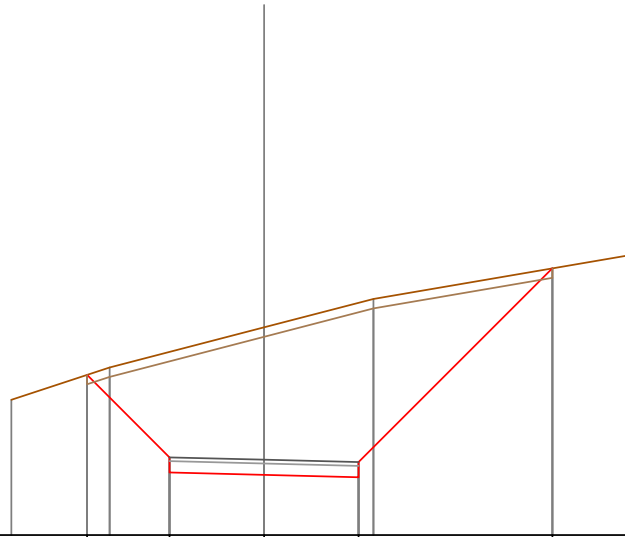

Quote	412.24	409.06	409.59	409.53	411.08
Parziali	2.18	2.50	2.50	5.13	
Sviluppata Par.	3.09	2.50	2.50	7.25	
Sviluppata	0.00	3.09	5.59	8.09	15.34
Progressiva	-4.68	-2.50	0.00	2.50	7.63
Dislivelli	0.00	-2.79	-3.90	-4.61	0.00

Sezione: 8
 Progressiva: 21.226
 Q. Progetto: 409.993

Scala H 1/200.00
 Scala V 1/200.00

408.00

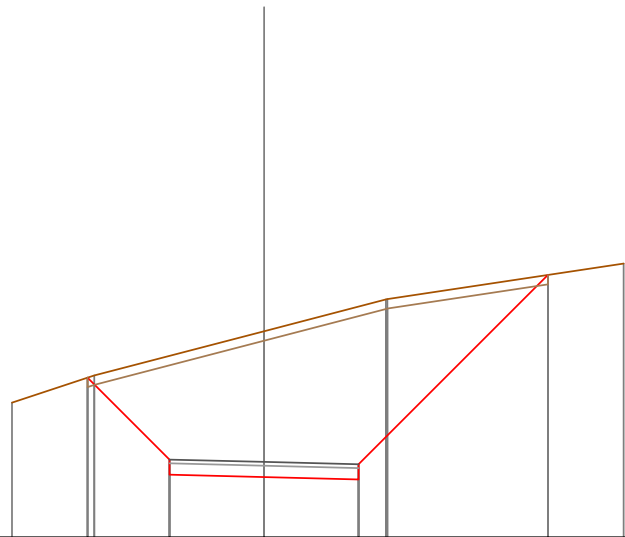

Quote	412.22	409.06	409.59	409.53	411.04
Parziali	2.17	2.50	2.50	5.01	
Sviluppata Par.	3.07	2.50	2.50	7.08	
Sviluppata	0.00	3.07	5.57	8.07	15.15
Progressiva	-4.67	-2.50	0.00	2.50	7.51
Dislivelli	0.00	-2.74	-3.86	-4.57	0.00

Sezione: 9
 Progressiva: 22.101
 Q. Progetto: 409.993

Scala H 1/200.00
 Scala V 1/200.00

408.00

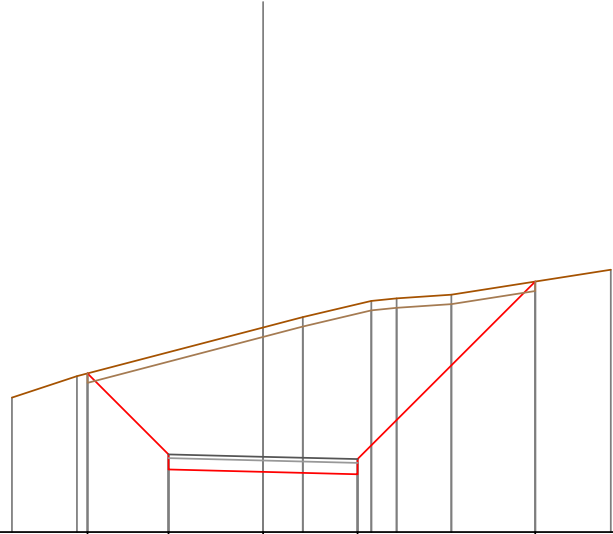

Quote	412.20	409.06	409.59	409.53	411.63
Parziali	2.14	2.50	2.50	4.70	
Sviluppata Par.	3.03	2.50	2.50	6.64	
Sviluppata	0.00	3.03	5.53	8.03	14.67
Progressiva	-4.64	-2.50	0.00	2.50	7.20
Dislivelli	0.00	-2.70	-3.82	-4.50	-0.00

Sezione: 10
 Progressiva: 28.534
 Q. Progetto: 409.991

Scala H 1/200.00
 Scala V 1/200.00

408.00

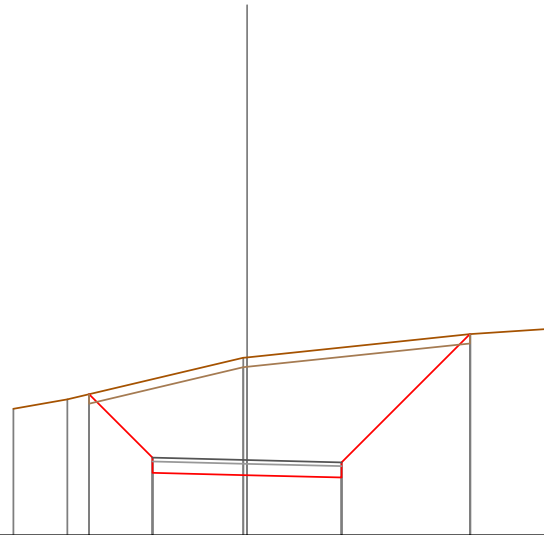

Quote	411.73	409.06	409.59	409.53	413.32
Parziali	1.68	2.50	2.50	3.39	
Sviluppata Par.	2.37	2.50	2.50	4.80	
Sviluppata	0.00	2.37	4.88	7.38	12.18
Progressiva	-4.18	-2.50	0.00	2.50	5.89
Dislivelli	0.00	-2.08	-3.11	-3.44	0.00

Sezione: 11
 Progressiva: 30.000
 Q. Progetto: 409.991

Scala H 1/200.00
 Scala V 1/200.00

408.00

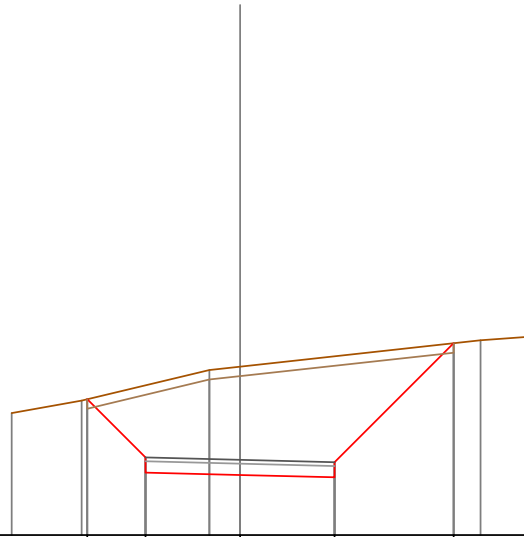

Quote	411.99	409.05	409.59	409.53	413.08
Parziali	1.54	2.50	2.50	3.15	
Sviluppata Par.	2.18	2.50	2.50	4.45	
Sviluppata	0.00	2.18	4.68	7.18	11.63
Progressiva	-4.04	-2.50	0.00	2.50	5.65
Dislivelli	-0.00	-1.91	-2.86	-3.20	0.00

Sezione: 12
 Progressiva: 35.952
 Q. Progetto: 409.989

Scala H 1/200.00
 Scala V 1/200.00

408.00

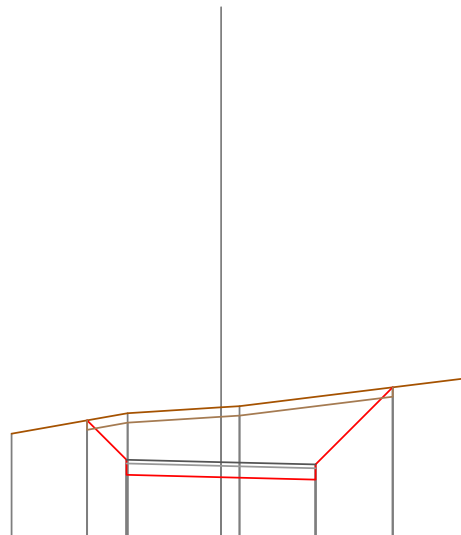

Quote	411.08	409.05	409.59	409.53	411.97
Parziali	1.04	2.50	2.50	2.04	
Sviluppata Par.	1.47	2.50	2.50	2.89	
Sviluppata	0.00	1.47	3.97	6.47	9.36
Progressiva	-3.54	-2.50	0.00	2.50	4.54
Dislivelli	-0.00	-1.23	-1.85	-2.19	-0.00

Sezione: 13
 Progressiva: 40.000
 Q. Progetto: 409.988

Scala H 1/200.00
 Scala V 1/200.00

408.00

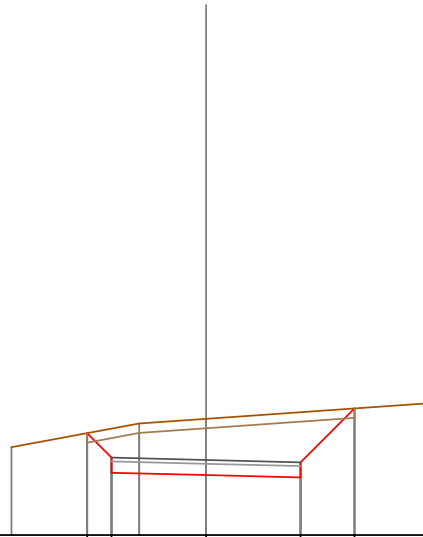

Quote	410.70	409.05	409.59	409.53	411.35
Parziali	0.65	2.50	2.50	1.43	
Sviluppata Par.	0.91	2.50	2.50	2.02	
Sviluppata	-0.00 + 3.15 + 0.00	-0.91	-3.41	-5.91	-7.93
Progressiva	-0.00	-2.50	0.00	2.50	3.93
Dislivelli	-0.77	-1.49	-1.73	-0.00	

Sezione: 14
 Progressiva: 43.369
 Q. Progetto: 409.986

Scala H 1/200.00
 Scala V 1/200.00

408.00

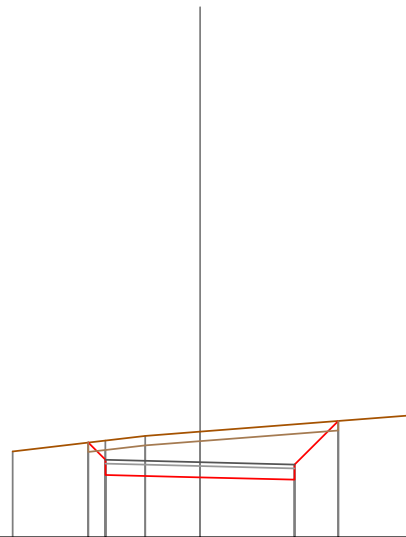

Quote	410.51	409.05	409.59	409.52	411.08
Parziali	0.46	2.50	2.50	1.15	
Sviluppata Par.	0.65	2.50	2.50	1.63	
Sviluppata	-0.00 + 2.96 + 0.00	-0.65	-3.15	-5.65	-7.28
Progressiva	-0.51	-2.50	0.00	2.50	3.65
Dislivelli	-0.00	-1.21	-1.46	-0.00	

Sezione: 15
 Progressiva: 46.962
 Q. Progetto: 409.985

Scala H 1/200.00
 Scala V 1/200.00

408.00

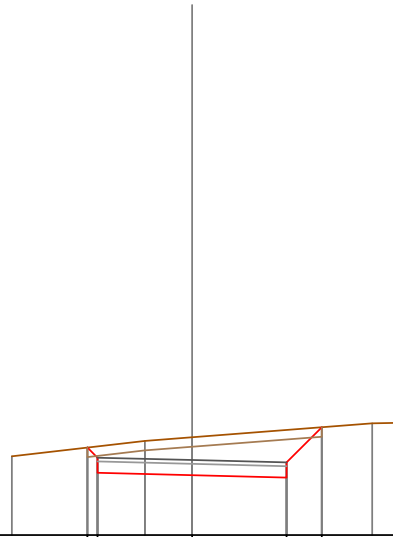

Quote	410.32 409.05	409.59	409.02	410.85
Parziali	0.27 2.50	2.50	0.93	
Sviluppata Par.	0.35 2.50	2.50	1.31	
Sviluppata	0.00 0.38	2.88	5.38	6.69
Progressiva	-2.77 -2.50	0.00	2.50	3.43
Dislivelli	0.00 -0.30	-1.00	-1.26	-0.00

Sezione: 16
 Progressiva: 50.000
 Q. Progetto: 409.984

Scala H 1/200.00
 Scala V 1/200.00

408.00

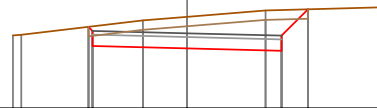

Quote	410.15 409.05	409.58	409.02	410.82
Parziali	2.50	2.50	0.70	
Sviluppata Par.	2.50	2.50	0.98	
Sviluppata	0.00 0.15	2.65	5.15	6.14
Progressiva	-2.61 -2.50	0.00	2.50	3.20
Dislivelli	0.00 -0.12	-0.84	-1.08	-0.00

Sezione: 17
 Progressiva: 50.671
 Q. Progetto: 409.984

Scala H 1/200.00
 Scala V 1/200.00

408.00

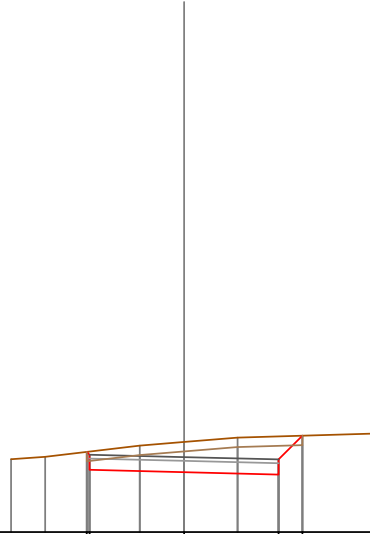

Quote		410.12 409.95	409.98	409.92 410.05
Parziali		2.50	2.50	0.63 0.89
Sviluppata Par.		2.50	2.50	0.89 0.63
Sviluppata		-0.00 -0.08	0.00 0.11	2.61 2.61
Progressiva		-2.57 -2.50	0.00 0.11	5.11 6.00
Dislivelli		-0.00 -0.08	0.00 0.11	-1.01 -0.00

Sezione: 18
 Progressiva: 54.379
 Q. Progetto: 409.983

Scala H 1/200.00
 Scala V 1/200.00

408.00

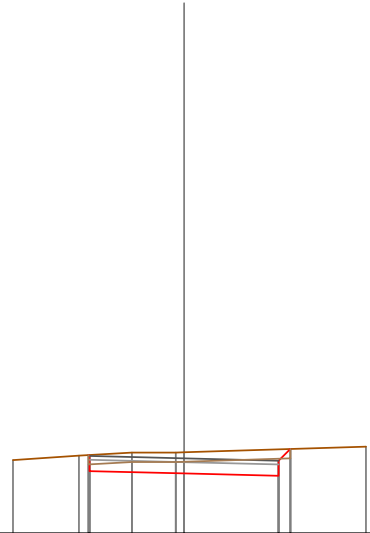

Quote		410.07 409.95	409.98	409.92 410.23
Parziali		2.50	2.50	0.31 0.84
Sviluppata Par.		2.50	2.50	0.84 0.31
Sviluppata		-0.00 -0.03	0.00 0.04	2.54 2.54
Progressiva		-2.53 -2.50	0.00 0.04	5.04 5.48
Dislivelli		-0.00 -0.03	0.00 0.04	-0.70 -0.00

Sezione: 19
 Progressiva: 60.000
 Q. Progetto: 409.981

Scala H 1/200.00
 Scala V 1/200.00

408.00

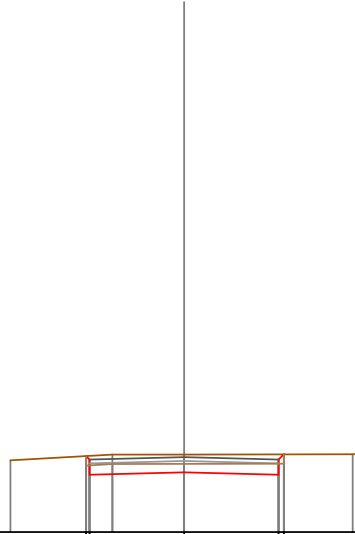

Quote	410.01 408.02	408.08	408.02 410.08
Parziali	2.50	2.50	
Sviluppata Par.	2.50	2.50	
Sviluppata	0.00 0.13	2.63	5.13 5.33
Progressiva	-2.59 -2.50	0.00	2.50 2.64
Dislivelli	0.00 -0.10	-0.47	-0.54 0.00

Sezione: 20
 Progressiva: 67.707
 Q. Progetto: 409.979

Scala H 1/200.00
 Scala V 1/200.00

408.00

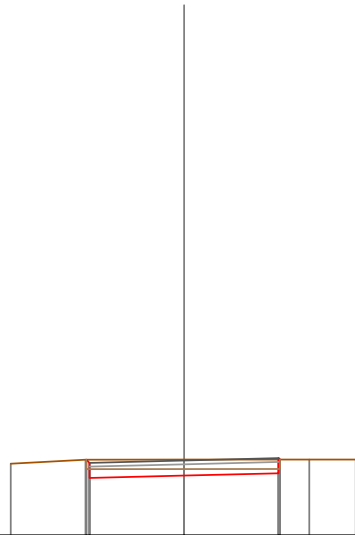

Quote	410.00 408.02	408.08	408.04 410.00
Parziali	2.50	2.50	
Sviluppata Par.	2.50	2.50	
Sviluppata	0.00 0.12	2.62	5.12 5.17
Progressiva	-2.58 -2.50	0.00	2.50 2.54
Dislivelli	0.00 -0.08	-0.42	-0.36 0.00

Sezione: 21
 Progressiva: 69.134
 Q. Progetto: 409.978

Scala H 1/200.00
 Scala V 1/200.00

408.00

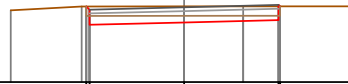

Quote	410.00 408.02	408.58	408.04 410.00
Parziali	2.50	2.50	
Sviluppata Par.	2.50	2.50	
Sviluppata	0.00 0.12	2.62	5.12 5.18
Progressiva	-2.58 -2.50	0.00	2.50 2.54
Dislivelli	0.00 -0.08	-0.42	-0.36 -0.00

Sezione: 22
 Progressiva: 70.000
 Q. Progetto: 409.978

Scala H 1/200.00
 Scala V 1/200.00

408.00

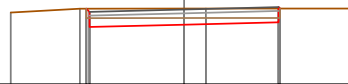

Quote	410.00 408.02	408.58	408.04 410.00
Parziali	2.50	2.50	
Sviluppata Par.	2.50	2.50	
Sviluppata	0.00 0.12	2.62	5.12 5.18
Progressiva	-2.59 -2.50	0.00	2.50 2.54
Dislivelli	0.00 -0.09	-0.42	-0.36 0.00

Sezione: 23
 Progressiva: 70.562
 Q. Progetto: 409.978

Scala H 1/200.00
 Scala V 1/200.00

408.00

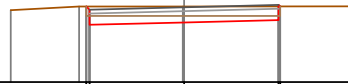

Quote	410.00 408.02	408.58	408.04 410.00
Parziali	2.50	2.50	
Sviluppata Par.	2.50	2.50	
Sviluppata	0.00 0.12	2.62	5.12 5.18
Progressiva	-2.59 -2.50	0.00	2.50 2.54
Dislivelli	0.00 -0.09	-0.42	-0.36 -0.00

Sezione: 24
 Progressiva: 71.380
 Q. Progetto: 409.978

Scala H 1/200.00
 Scala V 1/200.00

408.00



Quote	410.00 408.02	408.58	408.04 410.00
Parziali	2.50	2.50	
Sviluppata Par.	2.50	2.50	
Sviluppata	0.00 0.12	2.62	5.12 5.18
Progressiva	-2.59 -2.50	0.00	2.50 2.54
Dislivelli	0.00 -0.09	-0.42	-0.36 -0.00

Sezione: 25
 Progressiva: 74.837
 Q. Progetto: 409.977

Scala H 1/200.00
 Scala V 1/200.00

408.00

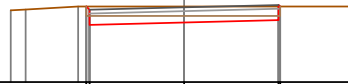

Quote	410.00 409.91	409.98	409.04 410.00
Parziali	2.50	2.50	
Sviluppata Par.	2.50	2.50	
Sviluppata	0.00 0.12	2.62	5.12 5.18
Progressiva	-2.59 -2.50	0.00	2.50 2.54
Dislivelli	0.00 -0.09	-0.42	-0.36 -0.00

Sezione: 26
 Progressiva: 78.293
 Q. Progetto: 409.976

Scala H 1/200.00
 Scala V 1/200.00

408.00

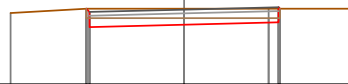

Quote	410.00 409.91	409.98	409.04 410.00
Parziali	2.50	2.50	
Sviluppata Par.	2.50	2.50	
Sviluppata	0.00 0.12	2.62	5.12 5.18
Progressiva	-2.59 -2.50	0.00	2.50 2.54
Dislivelli	0.00 -0.09	-0.42	-0.36 -0.00

Sezione: 27
 Progressiva: 80.000
 Q. Progetto: 409.975

Scala H 1/200.00
 Scala V 1/200.00

408.00

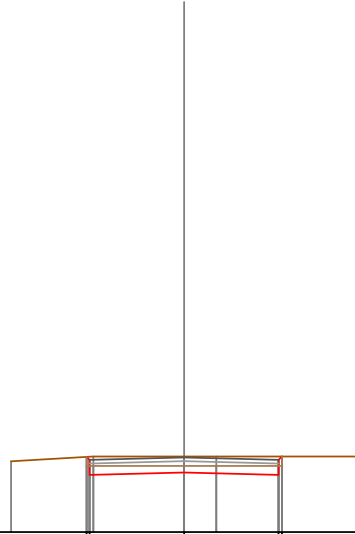

Quote	409.98 409.01	409.98 409.01	409.00 409.00	409.01 409.00
Parziali	2.50	2.50		
Sviluppata Par.	2.50	2.50		
Sviluppata	-0.00 -0.08	0.00 -2.50	0.11 -2.50	2.61 -0.42
Progressiva	-0.00 -0.08	2.50 -2.50	5.11 -0.49	5.23 -0.00
Dislivelli				

Sezione: 28
 Progressiva: 80.908
 Q. Progetto: 409.975

Scala H 1/200.00
 Scala V 1/200.00

408.00

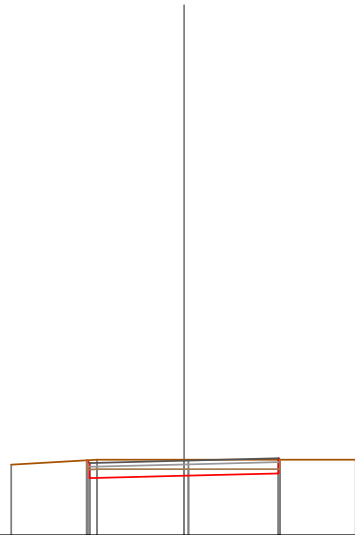

Quote	409.98 409.01	409.97 409.01	409.04 409.00
Parziali	2.50	2.50	
Sviluppata Par.	2.50	2.50	
Sviluppata	-0.00 -0.08	0.00 -2.50	0.10 -2.54
Progressiva	-0.00 -0.08	2.50 -2.50	5.10 -0.36
Dislivelli			

Sezione: 29
 Progressiva: 82.937
 Q. Progetto: 409.974

Scala H 1/200.00
 Scala V 1/200.00

408.00

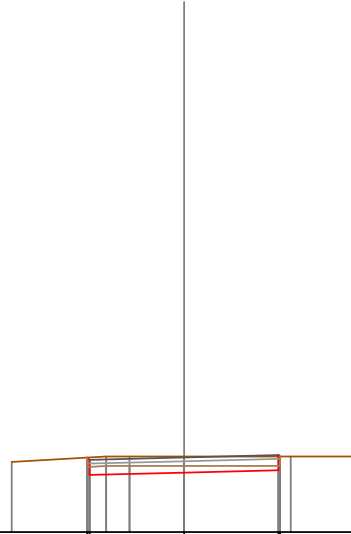

Quote		409.97 409.91	408.97	409.04 410.00
Parziali		2.50	2.50	
Sviluppata Par.		2.50	2.50	
Sviluppata		0.00 0.08	2.59	5.09 5.14
Progressiva		-2.56 -2.50	0.00	2.50 2.54
Dislivelli		0.00 -0.06	-0.43	-0.36 -0.00

Sezione: 30
 Progressiva: 84.965
 Q. Progetto: 409.974

Scala H 1/200.00
 Scala V 1/200.00

408.00

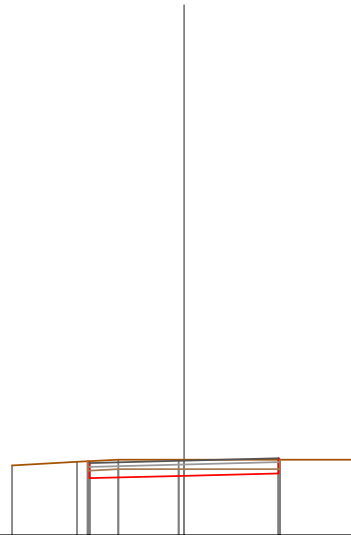

Quote		409.98 409.91	408.97	409.04 410.00
Parziali		2.50	2.50	
Sviluppata Par.		2.50	2.50	
Sviluppata		0.00 0.07	2.57	5.07 5.12
Progressiva		-2.55 -2.50	0.00	2.50 2.54
Dislivelli		0.00 -0.05	-0.43	-0.36 -0.00

Sezione: 31
 Progressiva: 93.226
 Q. Progetto: 409.971

Scala H 1/200.00
 Scala V 1/200.00

408.00

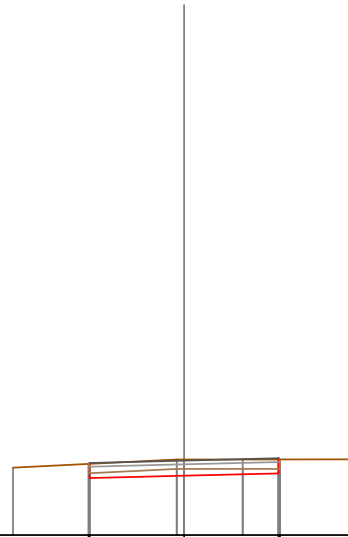

Quote	408.08 408.01	408.07	408.03 410.00
Parziali	2.50	2.50	
Sviluppata Par.	2.50	2.50	
Sviluppata	0.00 0.03	2.54	5.04 5.08
Progressiva	-2.52 -2.50	0.00	2.50 2.53
Dislivelli	0.00 0.02	-0.43	-0.37 -0.00

Sezione: 32
 Progressiva: 97.419
 Q. Progetto: 409.974

Scala H 1/200.00
 Scala V 1/200.00

408.00

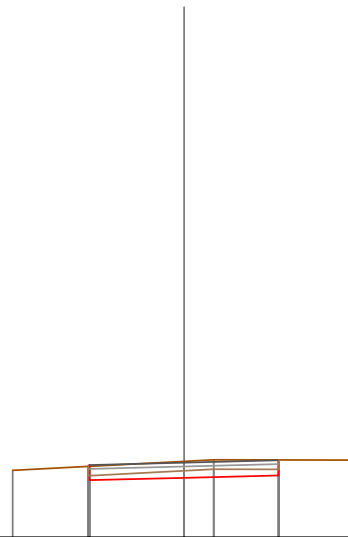

Quote	408.08 408.01	408.07	408.04 410.00
Parziali	2.50	2.50	
Sviluppata Par.	2.50	2.50	
Sviluppata	0.00 0.05	2.55	5.05
Progressiva	-2.53 -2.50	0.00	2.50
Dislivelli	0.00 0.03	-0.44	-0.41

Sezione: 33
 Progressiva: 100.000
 Q. Progetto: 409.990

Scala H 1/200.00
 Scala V 1/200.00

408.00



Quote		409.97 409.93		409.99		409.05 410.08
Parziali			2.50		2.50	
Sviluppata Par.			2.50		2.50	
Sviluppata		0.00 0.08		2.58		5.08 5.13
Progressiva		-2.56 -2.50		0.00		2.50 2.53
Dislivelli		-0.00 0.06		-0.41		-0.43 0.00

Sezione: 34
 Progressiva: 101.612
 Q. Progetto: 410.006

Scala H 1/200.00
 Scala V 1/200.00

408.00



Quote		409.98 409.94		409.91		409.07 410.11
Parziali			2.50		2.50	
Sviluppata Par.			2.50		2.50	
Sviluppata		0.00 0.12		2.62		5.12 5.17
Progressiva		-2.58 -2.50		0.00		2.50 2.54
Dislivelli		0.00 0.08		-0.39		-0.44 -0.00

Sezione: 35
 Progressiva: 111.866
 Q. Progetto: 410.231

Scala H 1/200.00
 Scala V 1/200.00

408.00

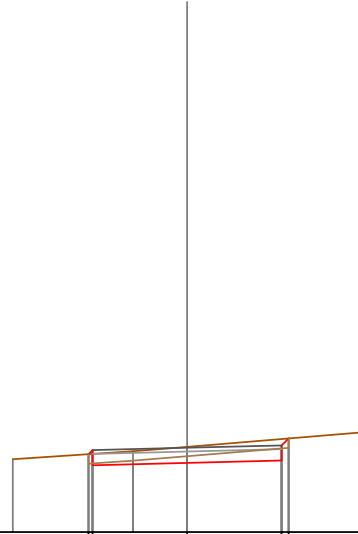

Quote	410.08 409.77	409.83	409.89 410.48
Parziali	2.50	2.50	0.33
Sviluppata Par.	2.50	2.50	0.33
Sviluppata	0.00 0.15	2.65	5.15 5.41
Progressiva	-2.61 -2.50	0.00	2.50 2.88
Dislivelli	0.00 0.10	-0.42	-0.57 -0.00

Sezione: 36
 Progressiva: 114.724
 Q. Progetto: 410.312

Scala H 1/200.00
 Scala V 1/200.00

408.00

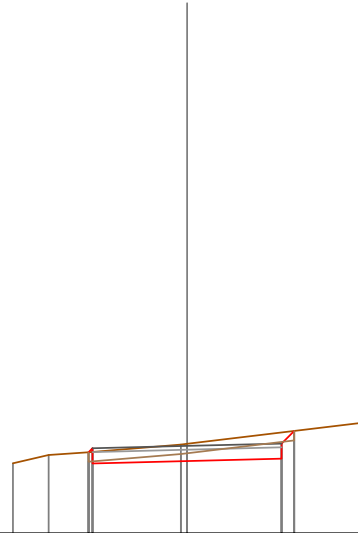

Quote	410.14 409.85	409.91	409.97 410.71
Parziali	2.50	2.50	0.33
Sviluppata Par.	2.50	2.50	0.33
Sviluppata	0.00 0.15	2.65	5.15 5.62
Progressiva	-2.61 -2.50	0.00	2.50 2.83
Dislivelli	0.00 0.10	-0.46	-0.69 -0.00

Sezione: 37
 Progressiva: 117.582
 Q. Progetto: 410.393

Scala H 1/200.00
 Scala V 1/200.00

408.00

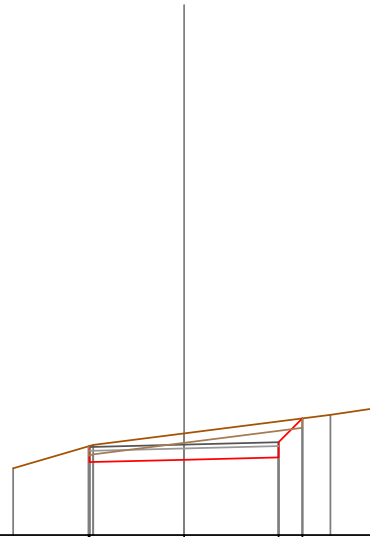

Quote	410.35 409.93	409.99	410.06 411.00
Parziali	2.50	2.50	0.63
Sviluppata Par.	2.50	2.50	0.89
Sviluppata	0.00 -0.03	2.53	5.03 5.92
Progressiva	-2.52 -2.50	0.00	2.50 3.13
Dislivelli	0.00 -0.03	-0.70	-0.95 -0.00

Sezione: 38
 Progressiva: 120.000
 Q. Progetto: 410.461

Scala H 1/200.00
 Scala V 1/200.00

408.00

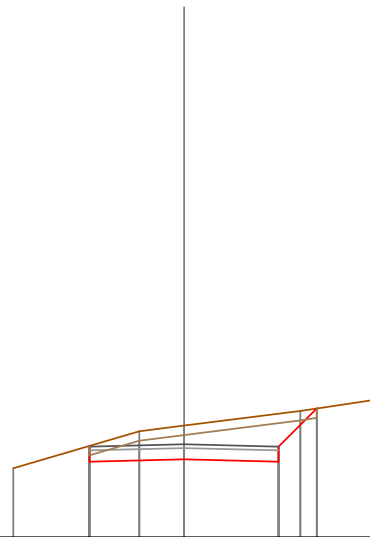

Quote	410.00	410.06	410.00 411.41
Parziali	2.50	2.50	1.01
Sviluppata Par.	2.50	2.50	1.43
Sviluppata	0.00	2.50	5.00 6.43
Progressiva	-2.52	0.00	2.50 3.51
Dislivelli	-0.00	-0.89	-1.27 -0.00

Sezione: 39
 Progressiva: 128.931
 Q. Progetto: 410.714

Scala H 1/200.00
 Scala V 1/200.00

408.00

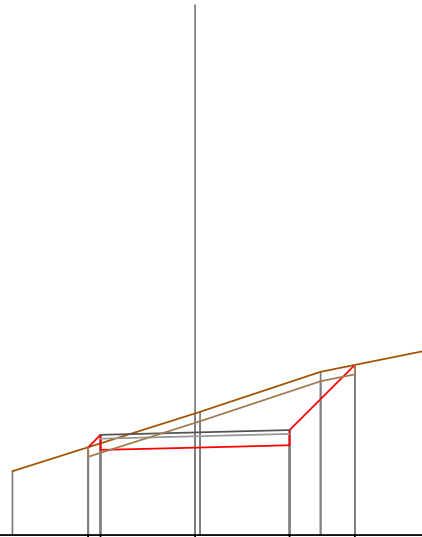

Quote	410.32	410.32	410.31	410.30	410.29
Parziali	0.33	2.50	2.50	1.73	
Sviluppata Par.	0.46	2.50	2.50	2.44	
Sviluppata	0.00	0.46	0.00	2.96	5.47
Progressiva	-2.83	-2.50	0.00	-2.50	-4.23
Dislivelli	0.00	-0.22	-0.91	-1.67	-0.00

Sezione: 40
 Progressiva: 130.000
 Q. Progetto: 410.745

Scala H 1/200.00
 Scala V 1/200.00

408.00

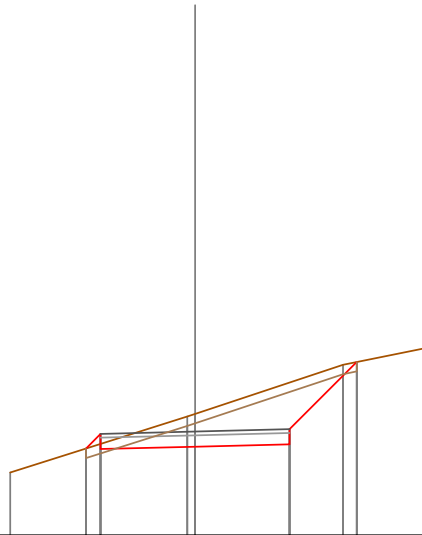

Quote	410.29	410.28	410.34	410.41	410.59
Parziali	0.39	2.50	2.50	1.78	
Sviluppata Par.	0.55	2.50	2.50	2.51	
Sviluppata	0.00	0.55	3.05	5.55	8.07
Progressiva	-2.89	-2.50	0.00	-2.50	-4.28
Dislivelli	0.00	-0.27	-0.87	-1.63	-0.00

Sezione: 41
 Progressiva: 133.841
 Q. Progetto: 410.854

Scala H 1/200.00
 Scala V 1/200.00

408.00

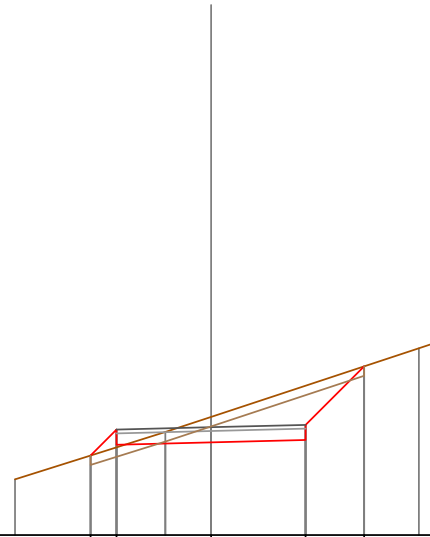

Quote		410.10	410.39	410.66	410.92	412.06
Parziali		0.69	2.50	2.50	1.55	
Sviluppata Par.		0.97	2.50	2.50	2.19	
Sviluppata		0.00	0.97	3.47	5.97	8.16
Progressiva		-3.19	-2.50	0.00	2.50	4.05
Dislivelli		0.00	-0.47	-0.67	-1.44	-0.00

Sezione: 42
 Progressiva: 138.752
 Q. Progetto: 410.993

Scala H 1/200.00
 Scala V 1/200.00

407.00

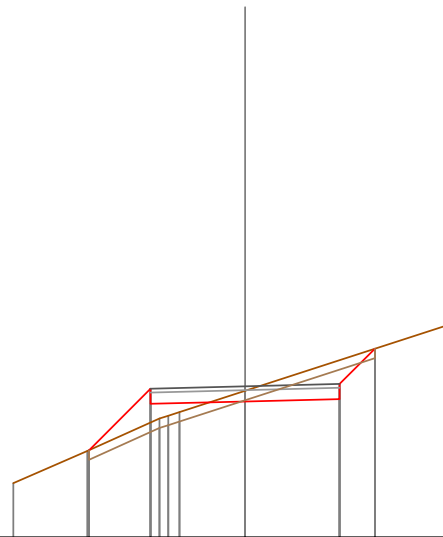

Quote		409.30	410.53	410.59	410.66	411.99
Parziali		1.63	2.50	2.50	0.93	
Sviluppata Par.		2.30	2.50	2.50	1.32	
Sviluppata		0.00	2.30	4.80	7.30	8.62
Progressiva		-4.13	-2.50	0.00	2.50	3.43
Dislivelli		0.00	-0.89	-0.28	-1.03	0.00

Sezione: 43
 Progressiva: 140.000
 Q. Progetto: 411.028

Scala H 1/200.00
 Scala V 1/200.00

407.00

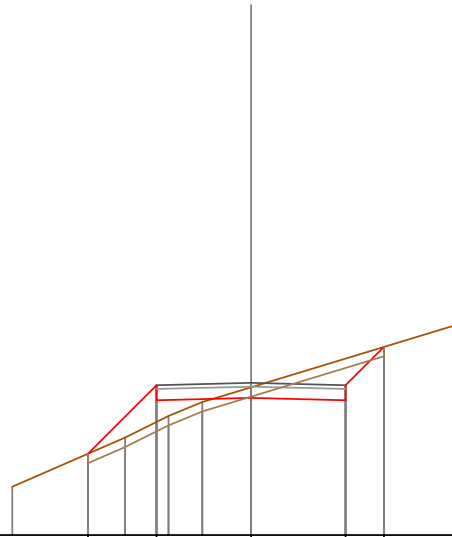

Quote	409.15	410.97	410.03	410.97	411.08
Parziali	1.81	2.50	2.50	1.01	
Sviluppata Par.	2.57	2.50	2.50	1.43	
Sviluppata	0.00	2.57	5.07	7.57	9.00
Progressiva	-4.31	-2.50	0.00	2.50	3.51
Dislivelli	-0.00	-0.97	-0.28	-1.11	0.00

Sezione: 44
 Progressiva: 160.000
 Q. Progetto: 411.595

Scala H 1/200.00
 Scala V 1/200.00

408.00

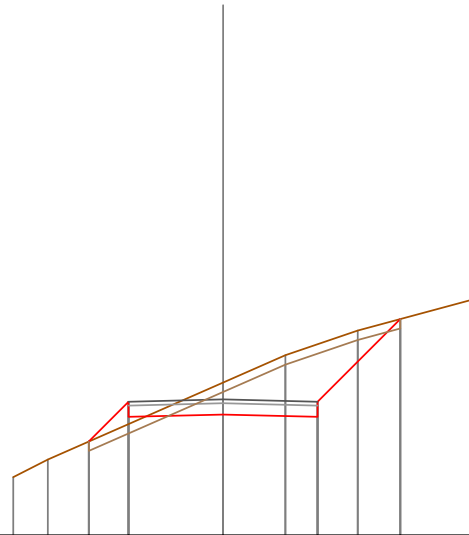

Quote	410.68	411.13	411.19	411.13	413.72
Parziali	1.05	2.50	2.50	2.19	
Sviluppata Par.	1.49	2.50	2.50	3.09	
Sviluppata	0.00	1.49	3.99	6.49	9.58
Progressiva	-3.55	-2.50	0.00	2.50	4.69
Dislivelli	-0.00	-0.59	-0.84	-1.92	0.00

Sezione: 45
 Progressiva: 160.201
 Q. Progetto: 411.601

Scala H 1/200.00
 Scala V 1/200.00

408.00

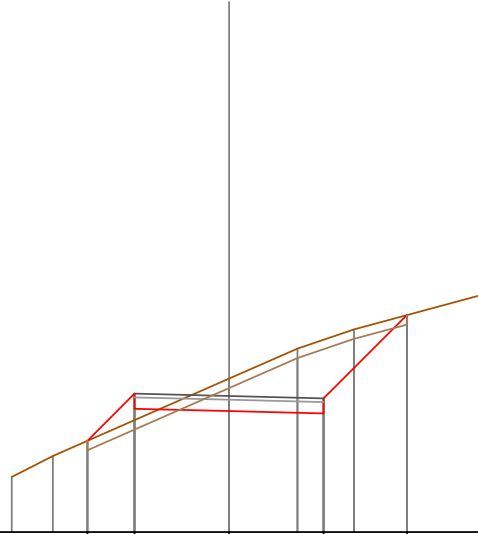

Quote	410.42	411.26	411.20	411.14	413.74
Parziali	1.25	2.50	2.50	2.20	
Sviluppata Par.	1.76	2.50	2.50	3.11	
Sviluppata	-0.00 + 3.75 + 0.00	-0.70 + 2.50 + 1.76	-0.86 + 0.00 + 4.27	-1.95 + 2.50 + 6.77	-0.00 + 4.70 + 9.88
Progressiva					
Dislivelli					

Sezione: 46
 Progressiva: 165.948
 Q. Progetto: 411.759

Scala H 1/200.00
 Scala V 1/200.00

409.00

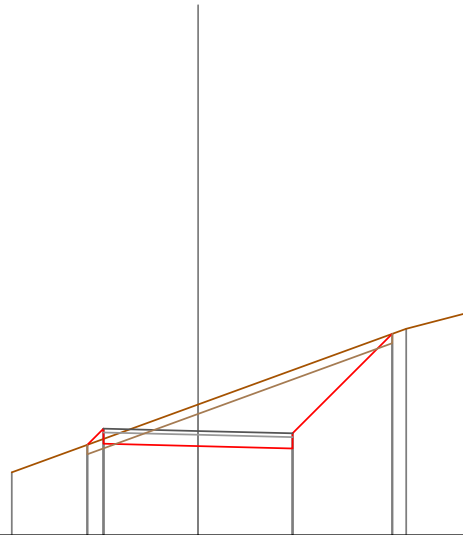

Quote	411.39	411.42	411.36	411.30	414.33
Parziali	0.61	0.43	2.50	2.50	2.63
Sviluppata Par.	0.61	0.61	2.50	2.50	3.73
Sviluppata	-0.00 + 2.93 + 0.00	-0.27 + 2.50 + 0.61	-1.10 + 0.00 + 3.11	-2.07 + 2.50 + 5.61	-0.00 + 5.13 + 9.33
Progressiva					
Dislivelli					

Sezione: 47
 Progressiva: 170.000
 Q. Progetto: 411.839

Scala H 1/200.00
 Scala V 1/200.00

410.00

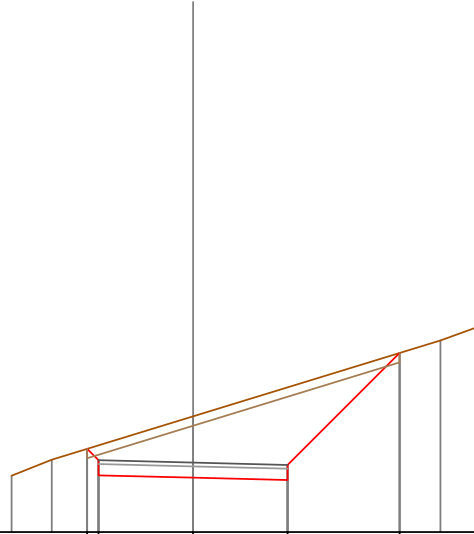

Quote	410.20 411.50	411.14	411.38	411.74
Parziali	0.30 2.50	2.50	2.96	
Sviluppata Par.	0.25 2.50	2.50	4.19	
Sviluppata	0.00 0.42	2.93	5.43	9.62
Progressiva	-2.80 -2.50	0.00	2.50	5.46
Dislivelli	0.00 -0.39	-1.62	-2.45	0.00

Sezione: 48
 Progressiva: 171.695
 Q. Progetto: 411.863

Scala H 1/200.00
 Scala V 1/200.00

410.00

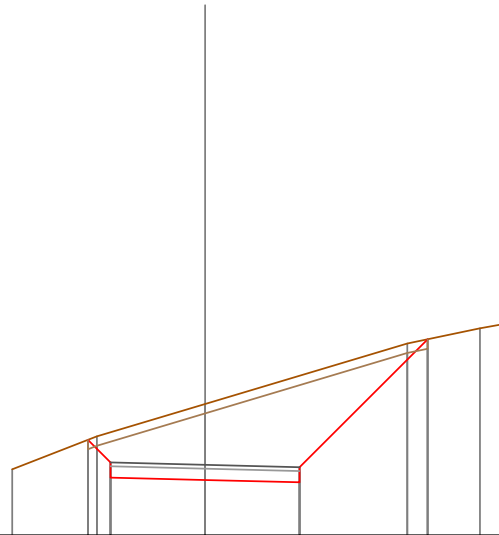

Quote	410.20 411.20	411.46	411.40	411.18
Parziali	0.60 2.50	2.50	3.38	
Sviluppata Par.	0.85 2.50	2.50	4.78	
Sviluppata	0.00 0.85	3.35	5.85	10.63
Progressiva	-3.10 -2.50	0.00	2.50	5.88
Dislivelli	0.00 -0.80	-2.01	-2.82	0.00

Sezione: 49
 Progressiva: 180.000
 Q. Progetto: 411.898

Scala H 1/200.00
 Scala V 1/200.00

410.00

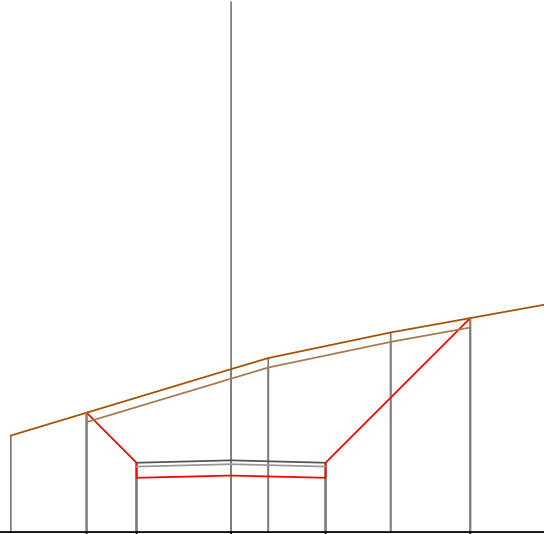

Quote	413.19	411.44	411.50	411.44	410.06
Parziali	1.32	2.50	2.50	3.83	
Sviluppata Par.	1.87	2.50	2.50	5.41	
Sviluppata	0.00	1.87	4.37	6.87	12.28
Progressiva	-3.82	-2.50	0.00	2.50	6.33
Dislivelli	0.00	-1.72	-2.81	-3.49	0.00

Sezione: 50
 Progressiva: 180.682
 Q. Progetto: 411.894

Scala H 1/200.00
 Scala V 1/200.00

410.00

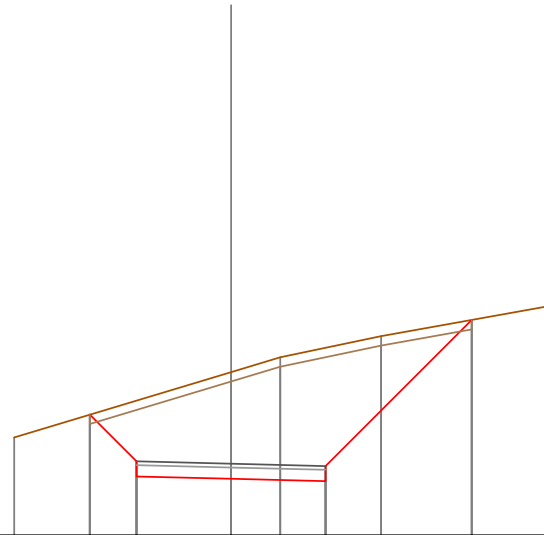

Quote	413.19	411.56	411.49	411.43	410.70
Parziali	1.24	2.50	2.50	3.86	
Sviluppata Par.	1.75	2.50	2.50	5.47	
Sviluppata	0.00	1.75	4.25	6.75	12.21
Progressiva	-3.74	-2.50	0.00	2.50	6.36
Dislivelli	0.00	-1.61	-2.82	-3.53	0.00

Sezione: 51
 Progressiva: 190.000
 Q. Progetto: 411.756

Scala H 1/200.00
 Scala V 1/200.00

410.00

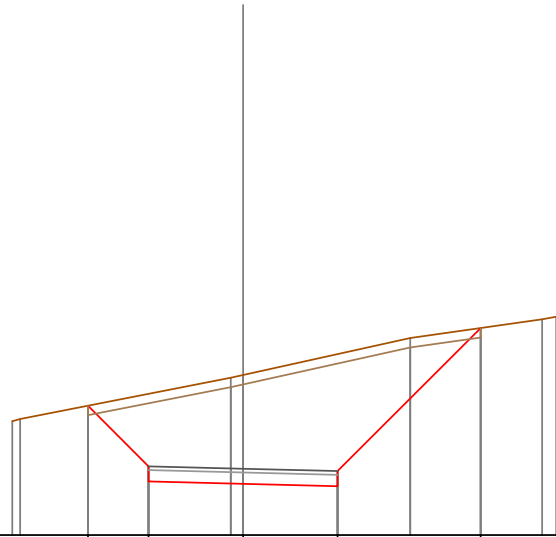



Quote		410.32	411.42	411.36	411.20	410.68
Parziali		1.60	2.50	2.50	3.78	
Sviluppata Par.		2.27	2.50	2.50	5.35	
Sviluppata		0.00	2.27	4.77	7.27	12.62
Progressiva		-4.10	-2.50	0.00	2.50	6.28
Dislivelli		0.00	-1.92	-2.88	-3.49	0.00

Sezione: 52
 Progressiva: 192.840
 Q. Progetto: 411.679

Scala H 1/200.00
 Scala V 1/200.00

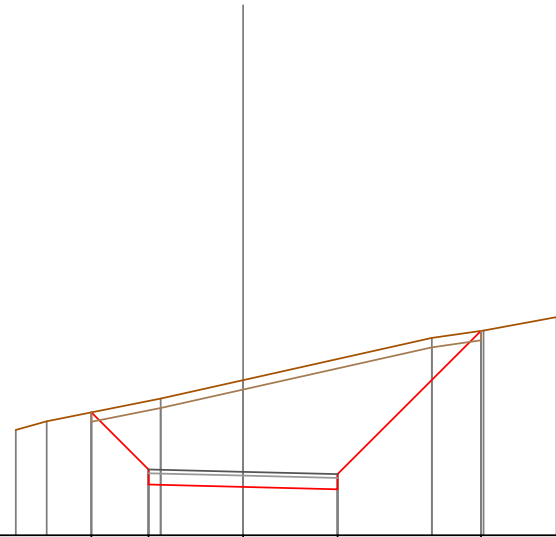
410.00





Quote		410.25	411.34	411.28	411.22	410.41
Parziali		1.51	2.50	2.50	3.79	
Sviluppata Par.		2.14	2.50	2.50	5.36	
Sviluppata		0.00	2.14	4.64	7.14	12.50
Progressiva		-4.01	-2.50	0.00	2.50	6.29
Dislivelli		0.00	-1.81	-2.83	-3.45	0.00

Sezione: 53
 Progressiva: 200.000
 Q. Progetto: 411.414

Scala H 1/200.00
 Scala V 1/200.00

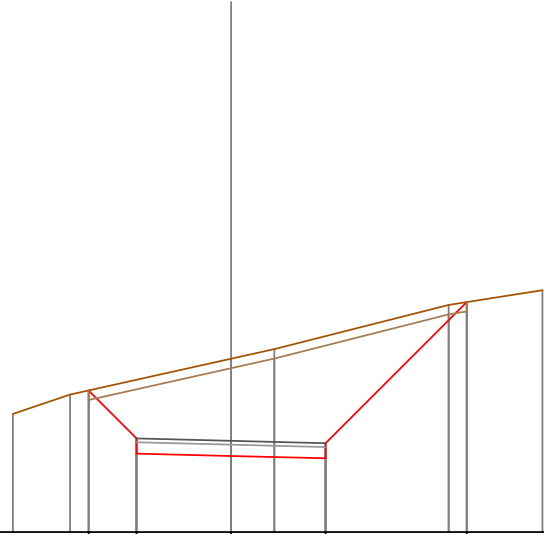
409.00



Quote	412.75	411.08	411.01	410.96	410.99
Parziali	1.27	2.50	2.50	3.73	
Sviluppata Par.	1.79	2.50	2.50	5.28	
Sviluppata	0.00	1.79	4.29	6.80	12.08
Progressiva	-3.77	-2.50	0.00	2.50	6.23
Dislivelli	0.00	-1.55	-2.57	-3.23	-0.00

Sezione: 54
 Progressiva: 204.998
 Q. Progetto: 411.168

Scala H 1/200.00
 Scala V 1/200.00

409.00

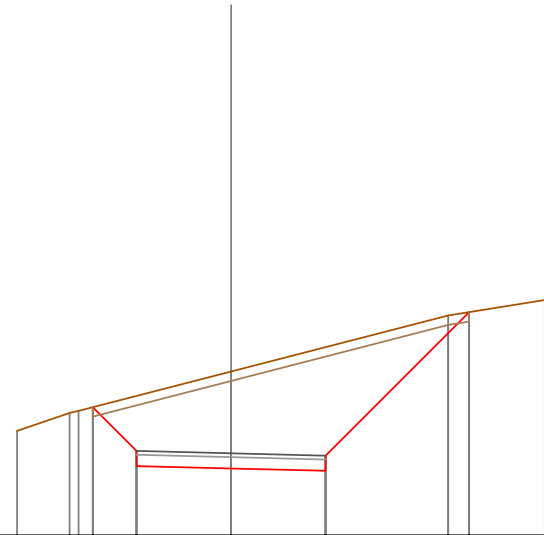

Quote	412.39	410.83	410.77	410.71	410.99
Parziali	1.16	2.50	2.50	3.80	
Sviluppata Par.	1.64	2.50	2.50	5.37	
Sviluppata	0.00	1.64	4.14	6.64	12.01
Progressiva	-3.66	-2.50	0.00	2.50	6.30
Dislivelli	0.00	-1.46	-2.56	-3.27	-0.00

Sezione: 55
 Progressiva: 205.234
 Q. Progetto: 411.155

Scala H 1/200.00
 Scala V 1/200.00

409.00

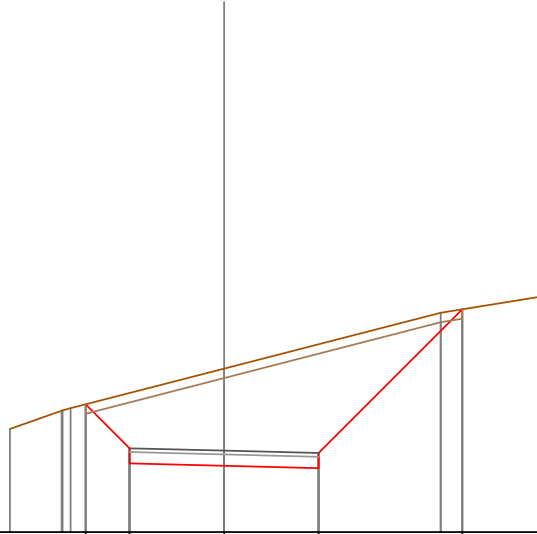

Quote	412.38	410.02	410.76	410.09	411.89
Parziali	1.16	2.50	2.50	3.80	
Sviluppata Par.	1.64	2.50	2.50	5.38	
Sviluppata	0.00	1.64	4.14	6.64	12.02
Progressiva	-3.66	-2.50	0.00	2.50	6.30
Dislivelli	-0.00	-1.46	-2.57	-3.28	-0.00

Sezione: 56
 Progressiva: 210.000
 Q. Progetto: 410.872

Scala H 1/200.00
 Scala V 1/200.00

409.00

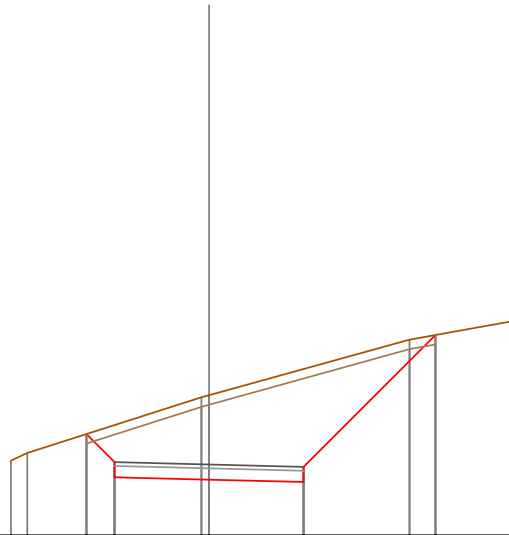

Quote	411.08	410.03	410.47	410.41	414.30
Parziali	0.74	2.50	2.50	3.49	
Sviluppata Par.	1.05	2.50	2.50	4.93	
Sviluppata	0.00	1.05	3.55	6.05	10.98
Progressiva	-3.24	-2.50	0.00	2.50	5.99
Dislivelli	-0.00	-0.98	-2.23	-2.99	-0.00

Sezione: 57
 Progressiva: 213.485
 Q. Progetto: 410.635

Scala H 1/200.00
 Scala V 1/200.00

409.00

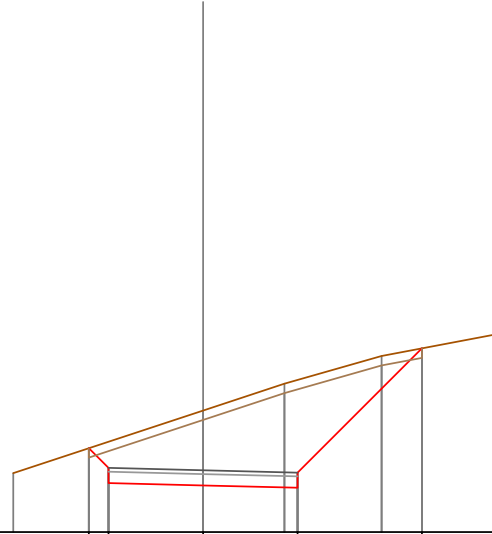

Quote	411.22	410.30	410.24	410.17	410.06
Parziali	0.52	2.50	2.50	3.29	
Sviluppata Par.	0.74	2.50	2.50	4.65	
Sviluppata	0.00	0.74	3.24	5.74	10.39
Progressiva	-3.02	-2.50	0.00	2.50	-5.79
Dislivelli	0.00	-0.69	-1.98	-2.65	-0.00

Sezione: 58
 Progressiva: 220.000
 Q. Progetto: 410.128

Scala H 1/200.00
 Scala V 1/200.00

408.00

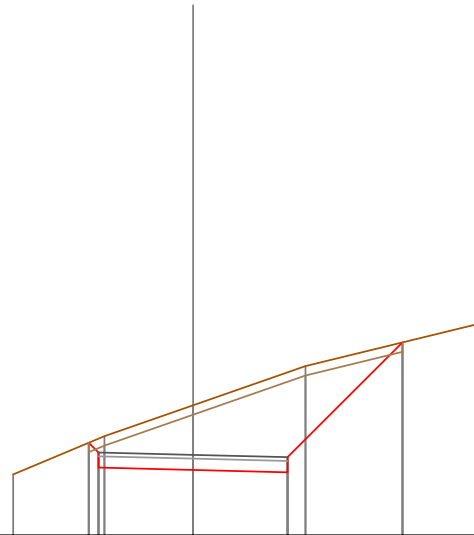

Quote	410.45	409.79	409.73	409.07	413.10
Parziali	0.26	2.50	2.50	3.04	
Sviluppata Par.	0.37	2.50	2.50	4.29	
Sviluppata	0.00	0.37	2.87	5.37	9.66
Progressiva	-2.76	-2.50	0.00	2.50	-5.54
Dislivelli	0.00	-0.37	-1.71	-2.65	-0.00

Sezione: 59
 Progressiva: 221.736
 Q. Progetto: 409.978

Scala H 1/200.00
 Scala V 1/200.00

408.00

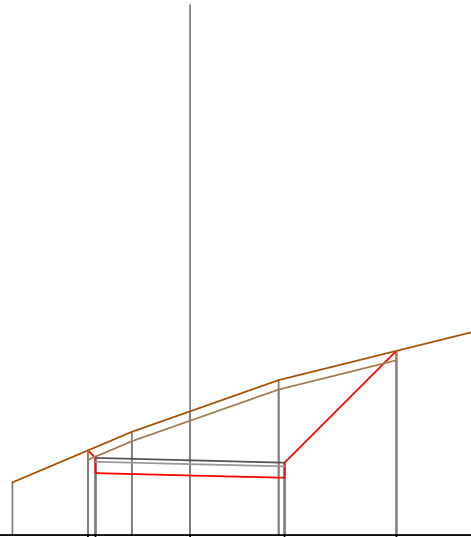

Quote	410.34 409.04	409.58	409.02	412.87
Parziali	2.50	2.50	2.96	
Sviluppata Par.	2.50	2.50	4.18	
Sviluppata	0.00 0.28	2.78	5.28	9.47
Progressiva	-2.70 -2.50	0.00	2.50	5.46
Dislivelli	0.00 -0.28	-1.70	-2.62	-0.00

Sezione: 60
 Progressiva: 240.000
 Q. Progetto: 408.033

Scala H 1/200.00
 Scala V 1/200.00

405.00

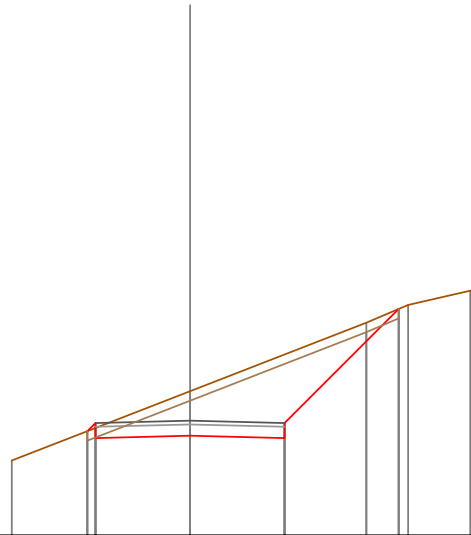

Quote	407.75 407.57	407.83	407.57	410.99
Parziali	2.50	2.50	3.02	
Sviluppata Par.	2.50	2.50	4.27	
Sviluppata	0.00 0.30	2.81	5.31	9.57
Progressiva	-2.72 -2.50	0.00	2.50	5.52
Dislivelli	0.00 -0.13	-1.18	-2.21	-0.00

Sezione: 61
 Progressiva: 255.883
 Q. Progetto: 405.799

Scala H 1/200.00
 Scala V 1/200.00

403.00

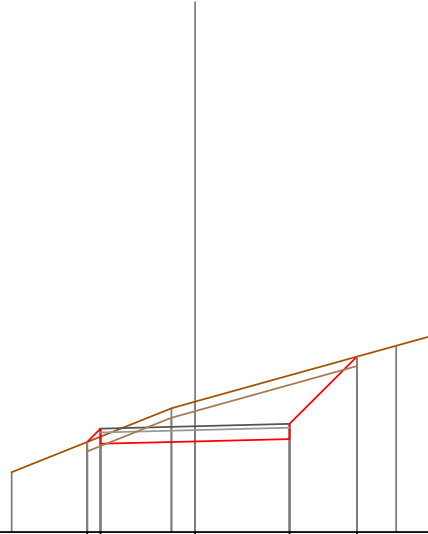

Quote	405.38 405.34	405.60	405.66	407.04
Parziali	0.35 2.50	2.50	1.78	
Sviluppata Par.	0.50 2.50	2.50	2.52	
Sviluppata	0.00 0.50	3.00	5.50	8.02
Progressiva	-2.85 -2.50	0.00	2.50	4.28
Dislivelli	-0.00 -0.21	-1.05	-1.68	-0.00

Sezione: 62
 Progressiva: 259.195
 Q. Progetto: 405.316

Scala H 1/200.00
 Scala V 1/200.00

403.00

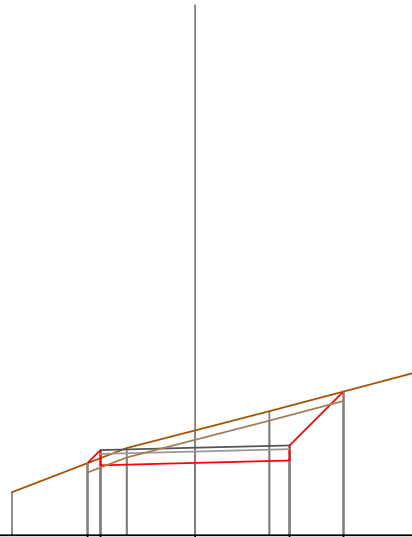

Quote	404.91 404.85	404.92	404.98	406.90
Parziali	0.34 2.50	2.50	1.42	
Sviluppata Par.	0.49 2.50	2.50	2.01	
Sviluppata	0.00 0.49	2.99	5.49	7.50
Progressiva	-2.84 -2.50	0.00	2.50	3.92
Dislivelli	-0.00 -0.21	-0.86	-1.45	-0.00

Sezione: 63
 Progressiva: 260.000
 Q. Progetto: 405.202

Scala H 1/200.00
 Scala V 1/200.00

403.00

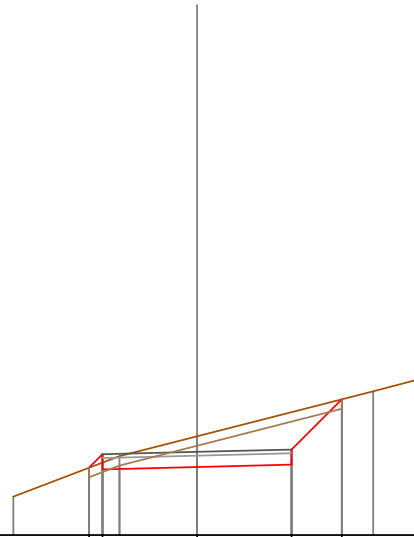

Quote	404.74	404.80	404.86	404.99
Parziali	0.36	2.50	2.50	1.33
Sviluppata Par.	0.51	2.50	2.50	1.88
Sviluppata	0.00	3.01	5.51	7.39
Progressiva	-2.86	0.00	2.50	3.83
Dislivelli	-0.22	-0.81	-1.39	-0.00

Sezione: 64
 Progressiva: 262.507
 Q. Progetto: 404.855

Scala H 1/200.00
 Scala V 1/200.00

402.00

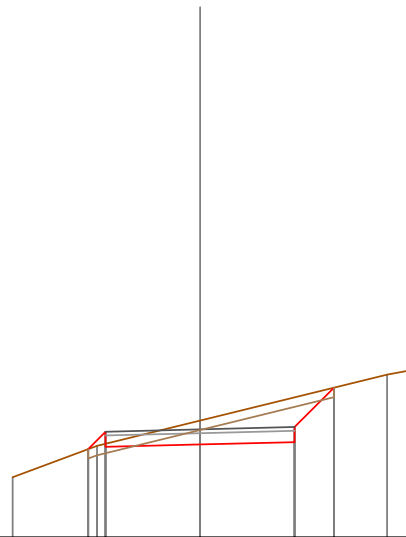

Quote	404.39	404.46	404.52	404.98
Parziali	0.46	2.50	2.50	1.04
Sviluppata Par.	0.65	2.50	2.50	1.47
Sviluppata	0.00	3.15	5.65	7.12
Progressiva	-2.96	0.00	2.50	3.54
Dislivelli	-0.32	-0.63	-1.18	-0.00

Sezione: 65
 Progressiva: 270.220
 Q. Progetto: 403.869

Scala H 1/200.00
 Scala V 1/200.00

401.00

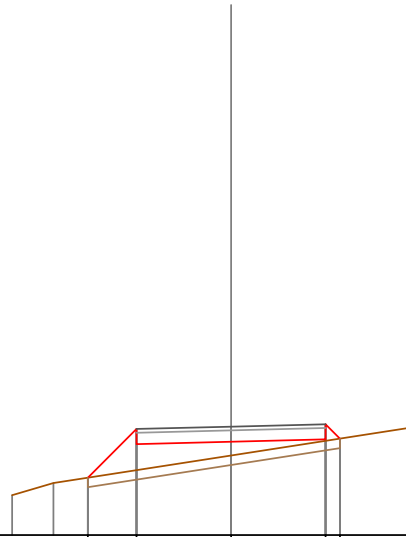

Quote	403.82	403.81	403.87	403.83	403.86
Parziali	1.29	2.50	2.50	0.38	
Sviluppata Par.	1.82	2.50	2.50	0.54	
Sviluppata	0.00	1.82	4.32	6.82	7.36
Progressiva	-3.79	-2.50	0.00	2.50	2.88
Dislivelli	0.00	1.09	0.36	0.04	0.00

Sezione: 66
 Progressiva: 273.333
 Q. Progetto: 403.506

Scala H 1/200.00
 Scala V 1/200.00

400.00

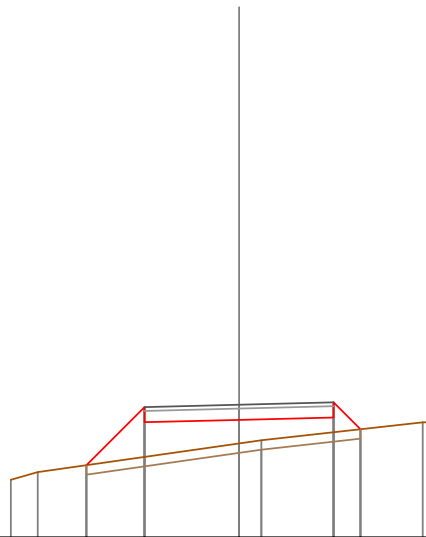

Quote	403.91	403.04	403.11	403.17	403.86
Parziali	1.54	2.50	2.50	0.71	
Sviluppata Par.	2.17	2.50	2.50	1.01	
Sviluppata	0.00	2.17	4.67	7.17	8.18
Progressiva	-4.04	-2.50	0.00	2.50	3.21
Dislivelli	0.00	1.32	0.62	0.39	0.00

Sezione: 67
 Progressiva: 276.446
 Q. Progetto: 403.163

Scala H 1/200.00
 Scala V 1/200.00

399.00

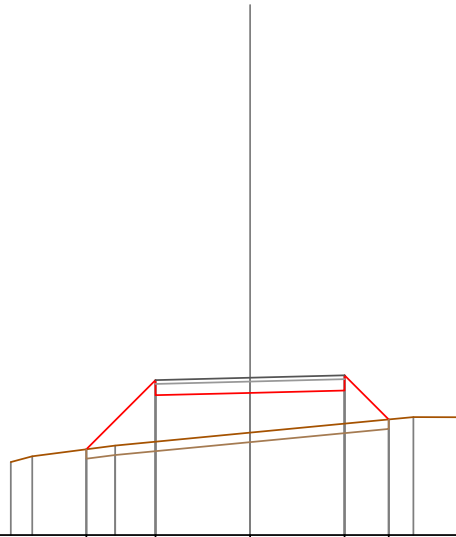

Quote		401.27	402.70	402.70	402.83	402.08
Parziali		1.83	2.50	2.50	1.17	
Sviluppata Par.		2.59	2.50	2.50	1.65	
Sviluppata		-0.00	2.59	5.09	7.59	9.24
Progressiva		-4.33	-2.50	0.00	2.50	3.67
Dislivelli		-0.00	-1.63	-1.05	-0.88	-0.00

Sezione: 68
 Progressiva: 280.000
 Q. Progetto: 402.794

Scala H 1/200.00
 Scala V 1/200.00

399.00

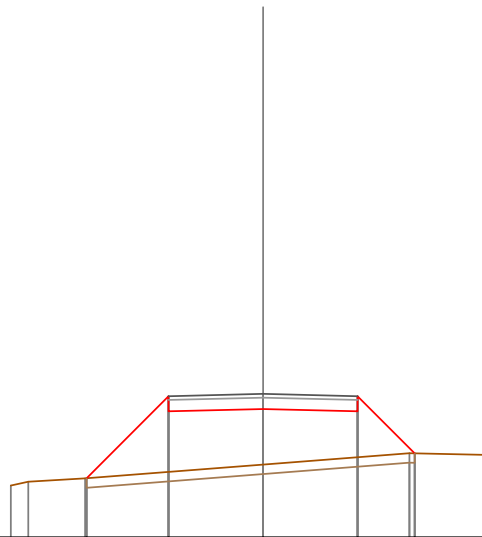

Quote		400.96	402.33	402.39	402.33	401.22
Parziali		2.17	2.50	2.50	1.51	
Sviluppata Par.		3.07	2.50	2.50	2.14	
Sviluppata		-0.00	3.07	5.57	8.07	10.21
Progressiva		-4.67	-2.50	0.00	2.50	4.01
Dislivelli		-0.00	-2.00	-1.47	-1.21	-0.00

Sezione: 69
 Progressiva: 300.000
 Q. Progetto: 401.199

Scala H 1/200.00
 Scala V 1/200.00

398.00

Quote	398.03	400.74	400.96	400.74	398.09
Parziali	1.51	2.50	2.50	1.44	
Sviluppata Par.	2.14	2.50	2.50	2.04	
Sviluppata	-0.00	2.14	4.64	7.14	9.18
Progressiva	-4.01	-2.50	0.00	2.50	3.94
Dislivelli	-0.00	-1.41	-0.90	-0.89	-0.00

Sezione: 70
 Progressiva: 320.000
 Q. Progetto: 400.409

Scala H 1/200.00
 Scala V 1/200.00

397.00

Quote	396.79	396.96	400.01	396.96	396.21
Parziali	0.56	2.50	2.50	1.14	
Sviluppata Par.	0.79	2.50	2.50	1.61	
Sviluppata	-0.00	0.79	3.29	5.79	7.40
Progressiva	-3.06	-2.50	0.00	2.50	3.64
Dislivelli	-0.00	-0.51	-0.23	-0.86	-0.00

Sezione: 71
 Progressiva: 340.000
 Q. Progetto: 400.039

Scala H 1/200.00
 Scala V 1/200.00

398.00

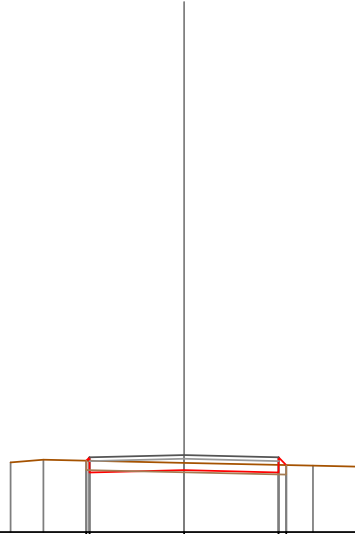

Quote		398.00	398.04	398.08	398.07
Parziali		2.50	2.50		
Sviluppata Par.		2.50	2.50		
Sviluppata		0.00	2.63	5.13	5.41
Progressiva		-2.59	0.00	2.50	2.70
Dislivelli		0.00	-0.19	-0.20	0.00

Sezione: 72
 Progressiva: 357.750
 Q. Progetto: 399.115

Scala H 1/200.00
 Scala V 1/200.00

397.00

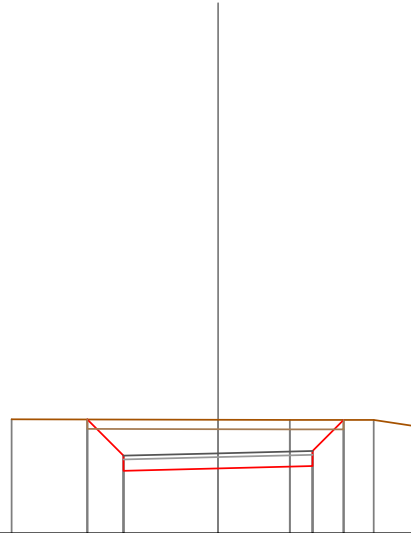

Quote		400.01	398.05	398.72	398.76	400.00
Parziali		0.96	2.50	2.50	0.82	
Sviluppata Par.		1.36	2.50	2.50	1.16	
Sviluppata		0.00	1.36	3.86	6.36	7.52
Progressiva		-3.46	-2.50	0.00	2.50	3.32
Dislivelli		0.00	-0.96	-1.29	-1.22	0.00

Sezione: 73
 Progressiva: 359.998
 Q. Progetto: 398.953

Scala H 1/200.00
 Scala V 1/200.00

397.00

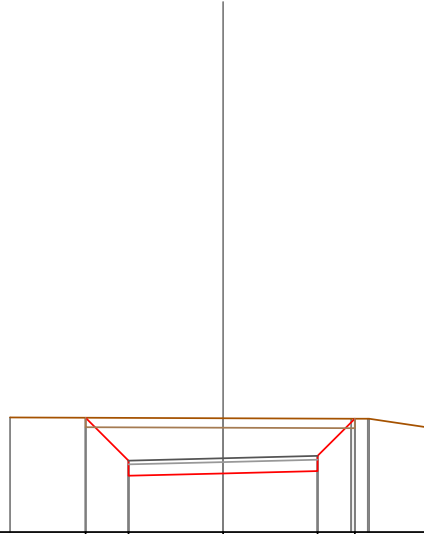

Quote	400.02	398.69	398.55	398.02	400.00
Parziali	1.13	2.50	2.50	0.99	
Sviluppata Par.	1.60	2.50	2.50	1.39	
Sviluppata	0.00	1.60	4.11	6.61	8.00
Progressiva	-3.63	-2.50	0.00	2.50	3.49
Dislivelli	0.00	-1.13	-1.46	-1.39	0.00

Sezione: 74
 Progressiva: 362.247
 Q. Progetto: 398.780

Scala H 1/200.00
 Scala V 1/200.00

397.00

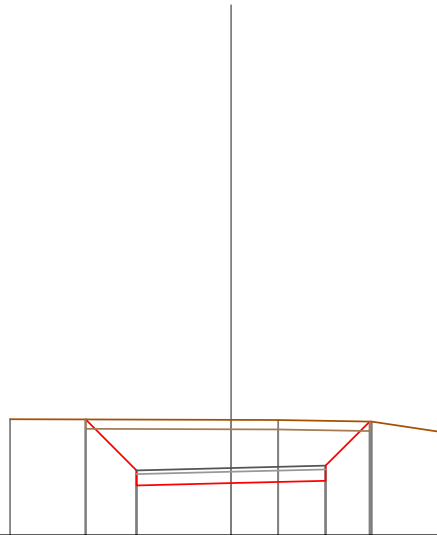

Quote	400.06	398.32	398.38	398.44	400.01
Parziali	1.35	2.50	2.50	1.17	
Sviluppata Par.	1.90	2.50	2.50	1.65	
Sviluppata	0.00	1.90	4.41	6.91	8.55
Progressiva	-3.85	-2.50	0.00	2.50	3.67
Dislivelli	0.00	-1.34	-1.67	-1.59	0.00

Sezione: 75
 Progressiva: 368.187
 Q. Progetto: 398.276

Scala H 1/200.00
 Scala V 1/200.00

396.00

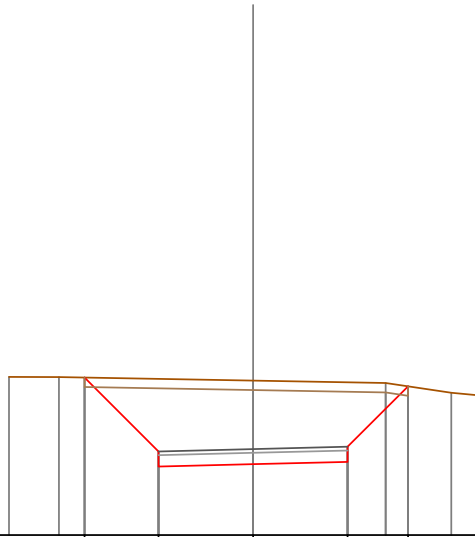

Quote		400.17	397.81	397.88	397.94	398.94
Parziali		1.96	2.50	2.50	1.60	
Sviluppata Par.		2.76	2.50	2.50	2.26	
Sviluppata		0.00	2.76	5.27	7.77	10.03
Progressiva		-4.46	-2.50	0.00	2.50	4.10
Dislivelli		0.00	-1.92	-2.21	-2.10	-0.00

Sezione: 76
 Progressiva: 370.000
 Q. Progetto: 398.107

Scala H 1/200.00
 Scala V 1/200.00

396.00

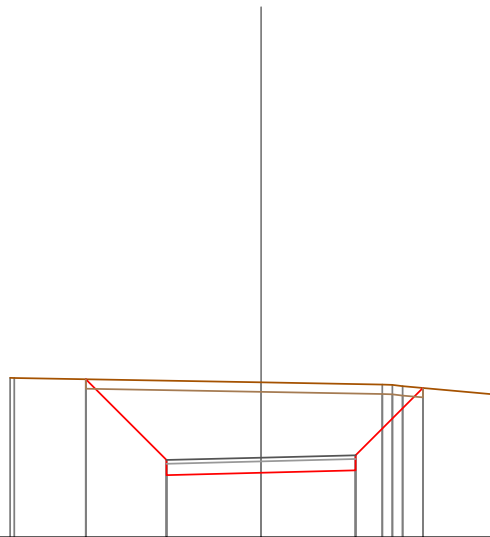

Quote		400.18	397.84	397.71	397.77	398.85
Parziali		2.14	2.50	2.50	1.78	
Sviluppata Par.		3.02	2.50	2.50	2.52	
Sviluppata		0.00	3.02	5.52	8.02	10.54
Progressiva		-4.64	-2.50	0.00	2.50	4.28
Dislivelli		-0.00	-2.10	-2.39	-2.28	-0.00

Sezione: 77
 Progressiva: 380.000
 Q. Progetto: 397.059

Scala H 1/200.00
 Scala V 1/200.00

395.00

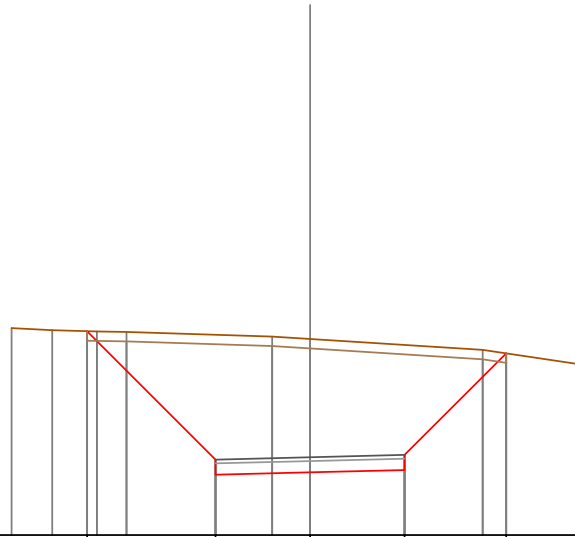

Quote		400.39	396.00	396.06	396.72	396.81
Parziali		3.40	2.50	2.50	2.69	
Sviluppata Par.		4.80	2.50	2.50	3.80	
Sviluppata		0.00	4.80	7.30	9.80	13.60
Progressiva		-5.90	-2.50	0.00	2.50	5.19
Dislivelli		0.00	-3.30	-3.53	-3.31	0.00

Sezione: 78
 Progressiva: 382.788
 Q. Progetto: 396.731

Scala H 1/200.00
 Scala V 1/200.00

395.00

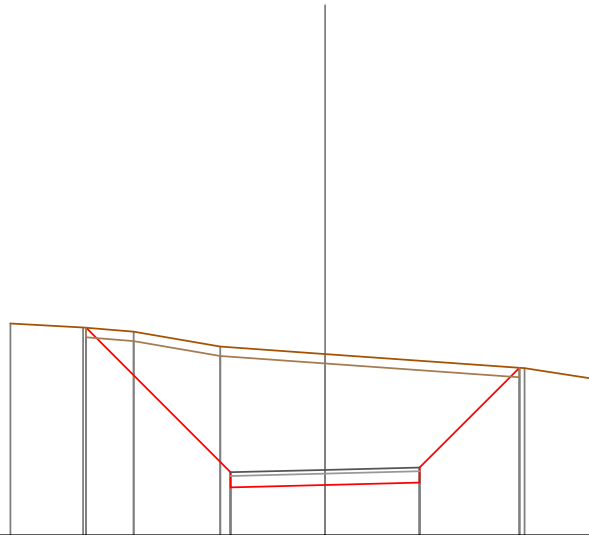

Quote		400.69	396.27	396.33	396.39	396.43
Parziali		3.82	2.50	2.50	2.64	
Sviluppata Par.		5.41	2.50	2.50	3.73	
Sviluppata		0.00	5.41	7.91	10.41	14.14
Progressiva		-6.32	-2.50	0.00	2.50	5.14
Dislivelli		0.00	-3.30	-3.46	-3.22	0.00

Sezione: 79
 Progressiva: 390.000
 Q. Progetto: 395.807

Scala H 1/200.00
 Scala V 1/200.00

394.00

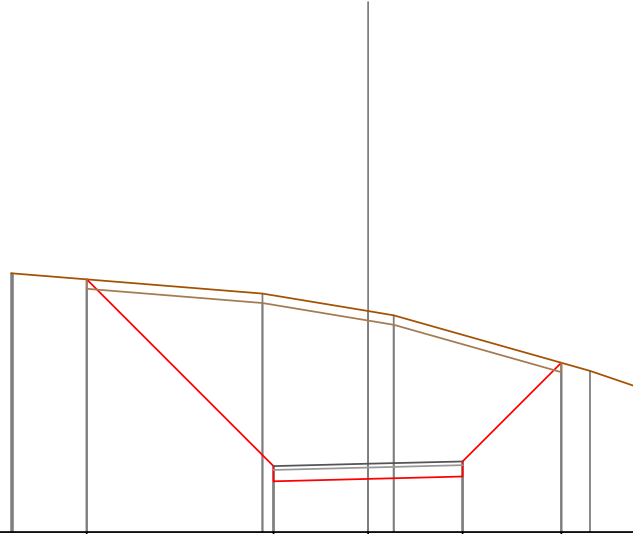



Quote		400.08	396.54	396.61	396.67	396.48
Parziali		4.94	2.50	2.50	2.61	
Sviluppata Par.		6.99	2.50	2.50	3.69	
Sviluppata		-0.00	-7.44	0.00	-6.99	-9.49
Progressiva		-0.00	-7.44	-2.50	0.00	-11.99
Dislivelli		-0.00	-4.51	-4.44	-3.75	-0.00

Sezione: 80
 Progressiva: 397.390
 Q. Progetto: 394.750

Scala H 1/200.00
 Scala V 1/200.00

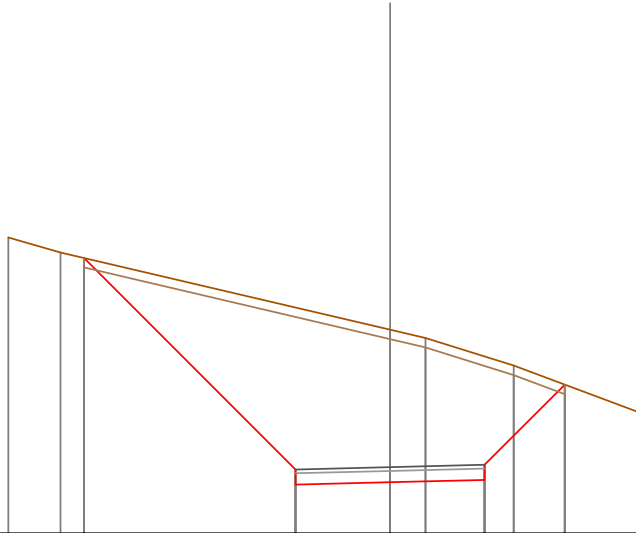
393.00





Quote		400.26	394.29	394.35	394.41	396.93
Parziali		5.59	2.50	2.50	2.12	
Sviluppata Par.		7.91	2.50	2.50	3.00	
Sviluppata		-0.00	-8.09	0.00	-7.91	-10.41
Progressiva		-0.00	-8.09	-2.50	0.00	-12.91
Dislivelli		-0.00	-4.28	-4.03	-3.26	-0.00

Sezione: 81
 Progressiva: 400.000
 Q. Progetto: 394.350

Scala H 1/200.00
 Scala V 1/200.00

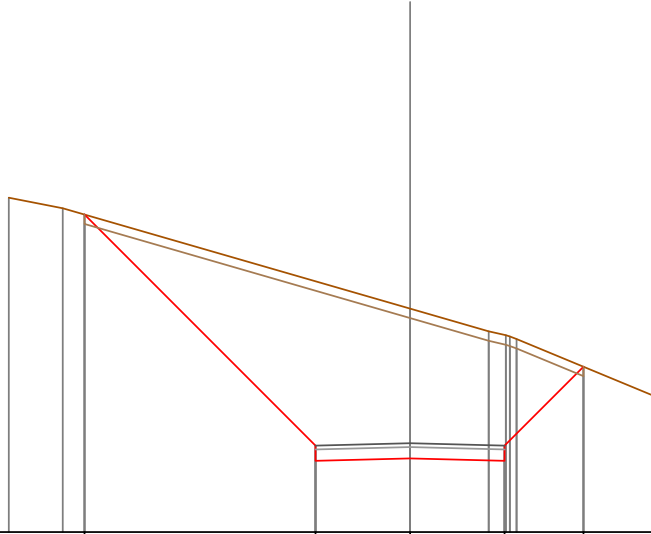
392.00



Quote		400.00	390.89	390.96	390.89	390.37
Parziali		6.11	2.50	2.50	2.09	
Sviluppata Par.		8.64	2.50	2.50	2.95	
Sviluppata		0.00	-8.64	-11.14	-13.64	-16.60
Progressiva		-8.61	-2.50	0.00	2.50	4.59
Dislivelli		-0.00	-4.35	-3.96	-3.33	0.00

Sezione: 82
 Progressiva: 410.112
 Q. Progetto: 392.665

Scala H 1/200.00
 Scala V 1/200.00

391.00

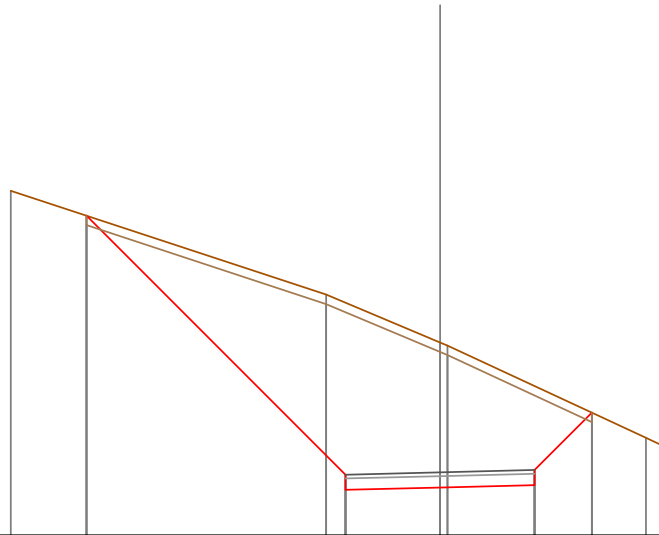

Quote		390.45	392.20	392.26	392.33	394.24
Parziali		6.85	2.50	2.50	1.52	
Sviluppata Par.		9.69	2.50	2.50	2.14	
Sviluppata		0.00	-9.69	-12.19	-14.69	-16.63
Progressiva		-9.35	-2.50	0.00	2.50	4.02
Dislivelli		-0.00	-4.55	-3.83	-2.62	0.00

Sezione: 83
 Progressiva: 419.716
 Q. Progetto: 390.866

Scala H 1/200.00
 Scala V 1/200.00

389.00

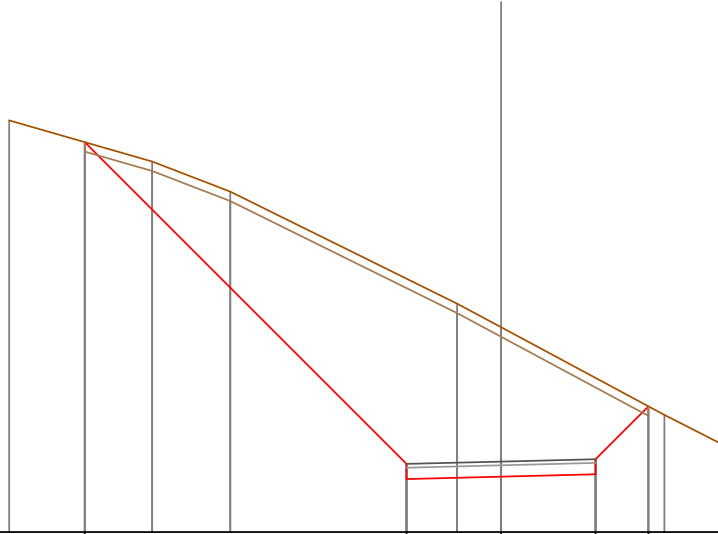



Quote	390.31	390.40	390.47	390.53	390.33
Parziali		8.51	2.50	2.50	1.40
Sviluppata Par.		12.04	2.50	2.50	1.98
Sviluppata	0.00	-12.04	-14.54	-17.04	-19.01
Progressiva	-11.01	-2.50	0.00	2.50	3.90
Dislivelli	0.00	-4.90	-3.95	-2.55	0.00

Sezione: 84
 Progressiva: 420.000
 Q. Progetto: 390.810

Scala H 1/200.00
 Scala V 1/200.00

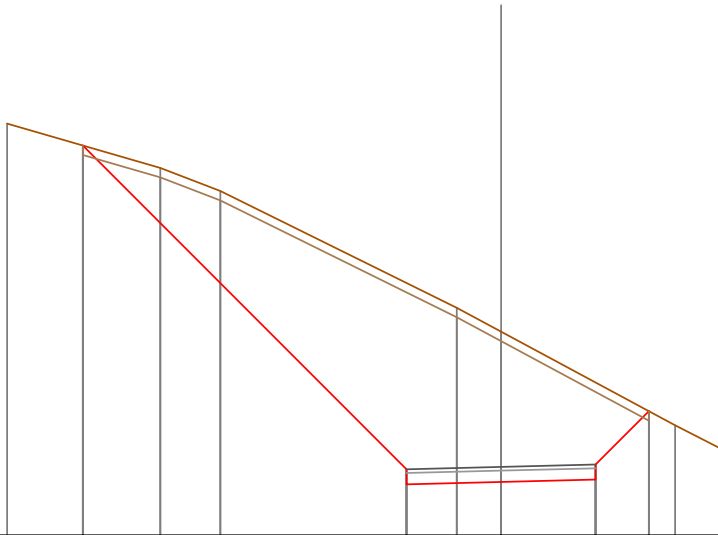
389.00

Quote	390.31	390.35	390.41	390.47	390.28
Parziali		8.56	2.50	2.50	1.41
Sviluppata Par.		12.11	2.50	2.50	1.99
Sviluppata	0.00	-12.11	-14.61	-17.11	-19.11
Progressiva	-11.06	-2.50	0.00	2.50	3.91
Dislivelli	0.00	-4.83	-3.98	-2.57	0.00

Sezione: 85
 Progressiva: 429.320
 Q. Progetto: 388.876

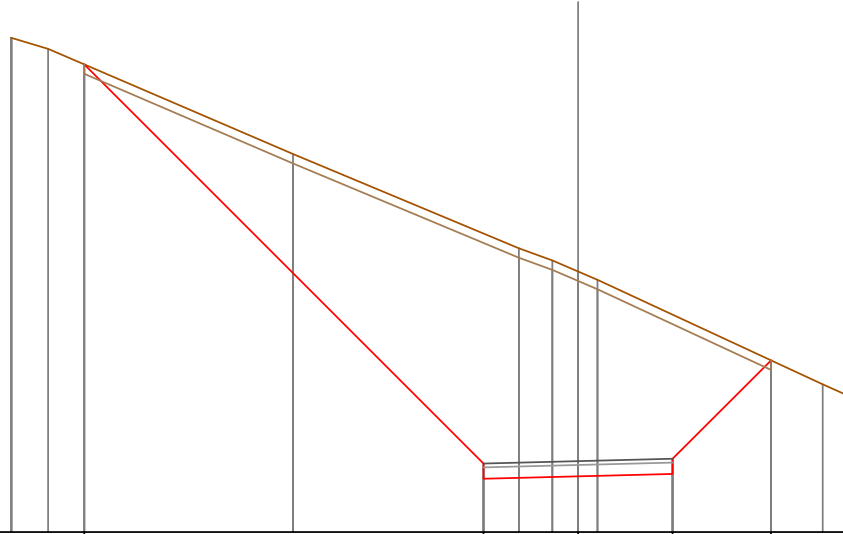

Scala H 1/200.00
 Scala V 1/200.00

Quote		388.37	388.41	388.48	388.54	388.54
Parziali		10.56	2.50	2.50	2.60	
Sviluppata Par.		14.93	2.50	2.50	3.68	
Sviluppata	0.00	0.00	-14.93	-17.43	-19.93	-23.62
Progressiva	-13.06	-13.06	-2.50	0.00	2.50	5.10
Dislivelli	0.00	0.00	-6.08	-5.42	-4.21	-0.00

Sezione: 86
 Progressiva: 437.680
 Q. Progetto: 387.086

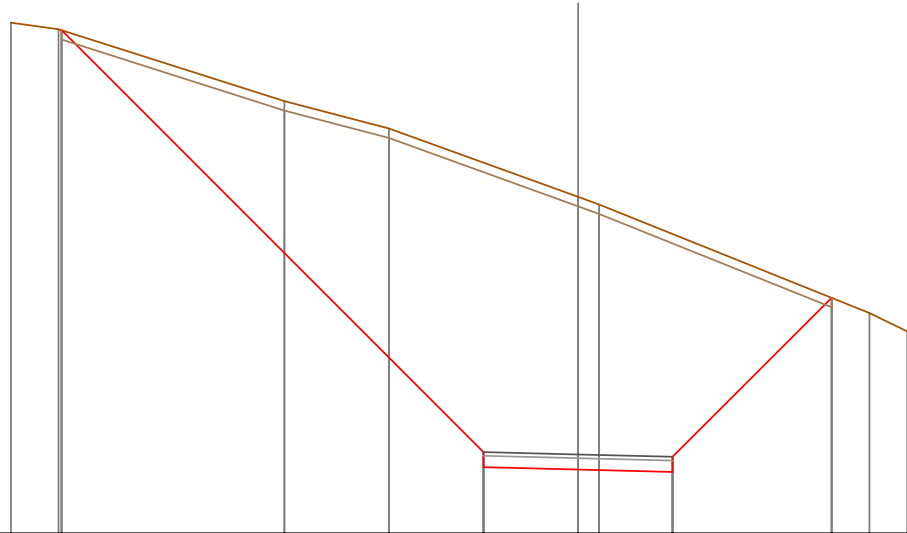

Scala H 1/200.00
 Scala V 1/200.00

Quote		388.31	388.75	388.89	389.02	389.25
Parziali		11.16	2.50	2.50	4.20	
Sviluppata Par.		15.78	2.50	2.50	5.95	
Sviluppata	0.00	0.00	-15.78	-18.28	-20.79	-26.73
Progressiva	-13.06	-13.06	-2.50	0.00	2.50	6.70
Dislivelli	0.00	0.00	-7.65	-7.21	-6.29	-0.00

Sezione: 87
 Progressiva: 440.000
 Q. Progetto: 386.589

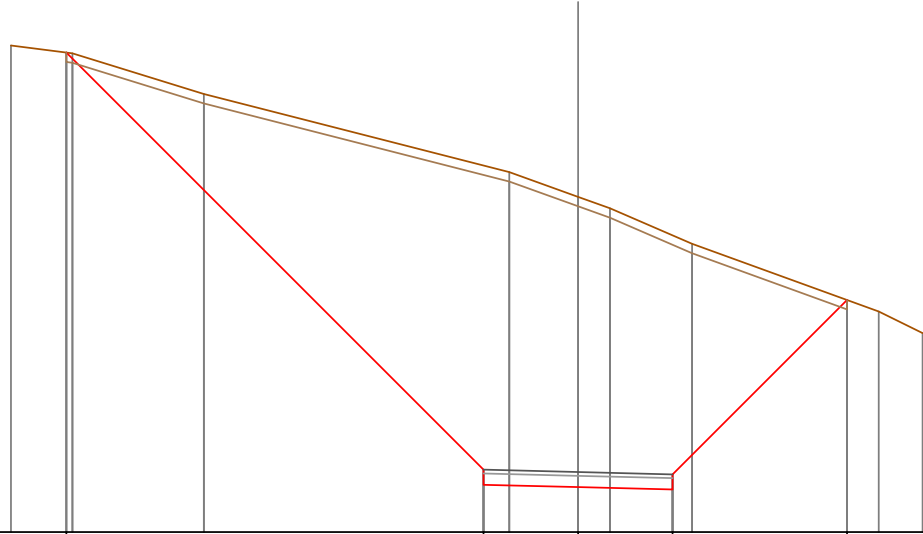

Scala H 1/200.00
 Scala V 1/200.00

385.00

Quote		387.69		386.25	386.19	386.13		381.14
Parziali			11.03		2.50	2.50		4.61
Sviluppata Par.			15.60		2.50	2.50		6.52
Sviluppata		0.00		-15.60	-18.11	-20.61		-27.13
Progressiva		-13.35		-2.50	0.00	2.50		7.11
Dislivelli		0.00		-8.05	-7.68	-6.72		0.00

Sezione: 88
 Progressiva: 441.628
 Q. Progetto: 386.241

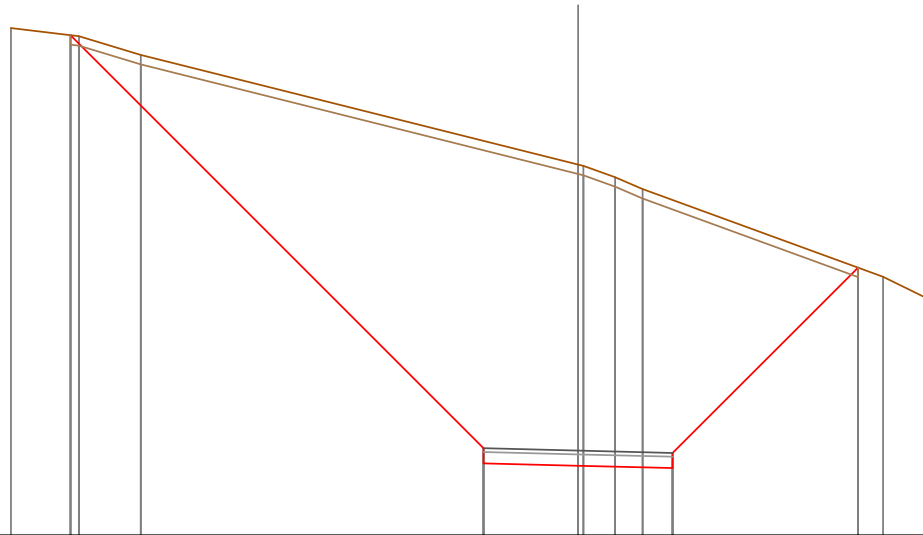

Scala H 1/200.00
 Scala V 1/200.00

384.00

Quote		387.23		385.90	385.84	385.78		381.08
Parziali			10.92		2.50	2.50		4.90
Sviluppata Par.			15.45		2.50	2.50		6.93
Sviluppata		0.00		-15.45	-17.95	-20.45		-27.38
Progressiva		-13.42		-2.50	0.00	2.50		7.40
Dislivelli		0.00		-8.13	-7.97	-7.09		0.00

Sezione: 89
 Progressiva: 445.577
 Q. Progetto: 385.395

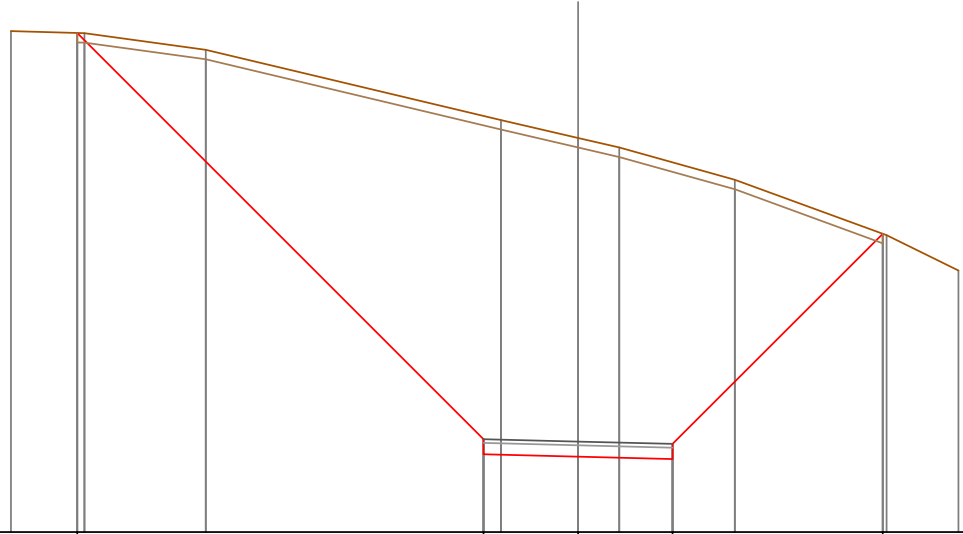

Scala H 1/200.00
 Scala V 1/200.00

383.00
 ▽

Quote	385.20	385.06	385.00	384.93	384.88
Parziali	10.75	2.50	2.50	5.56	
Sviluppata Par.	15.20	2.50	2.50	7.86	
Sviluppata	0.00	-15.20	-17.70	-20.20	-28.06
Progressiva	-13.25	-2.50	0.00	2.50	8.06
Dislivelli	-0.00	-8.55	-8.43	-7.85	-0.00

Sezione: 90
 Progressiva: 460.000
 Q. Progetto: 382.308

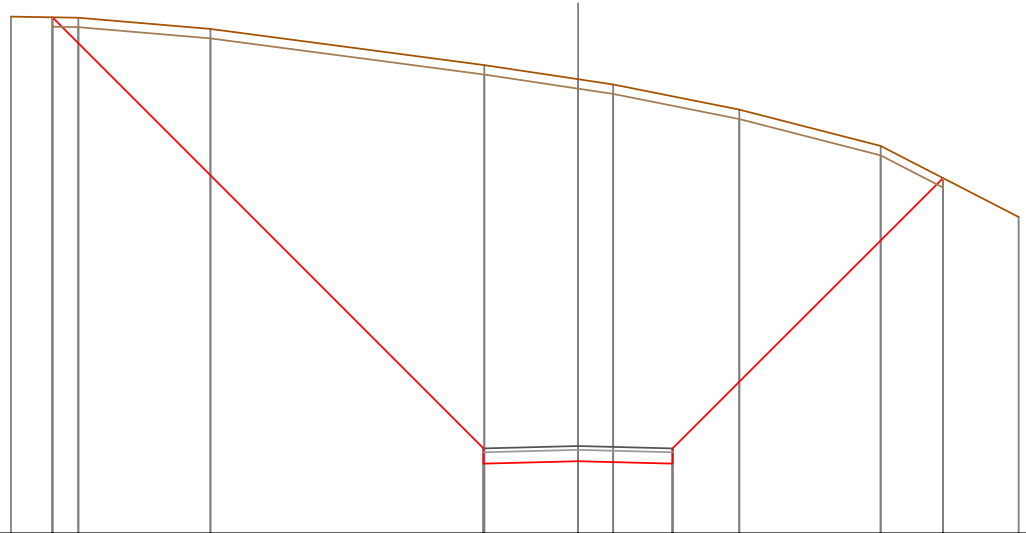

Scala H 1/200.00
 Scala V 1/200.00

380.00
 ▽

Quote	380.05	381.85	381.91	381.85	380.40
Parziali	11.40	2.50	2.50	7.15	
Sviluppata Par.	16.13	2.50	2.50	10.11	
Sviluppata	0.00	-16.13	-18.63	-21.13	-31.24
Progressiva	-15.00	-2.50	0.00	2.50	9.65
Dislivelli	-0.00	-0.14	-0.11	-9.71	-0.00

Sezione: 91
 Progressiva: 462.391
 Q. Progetto: 381.796

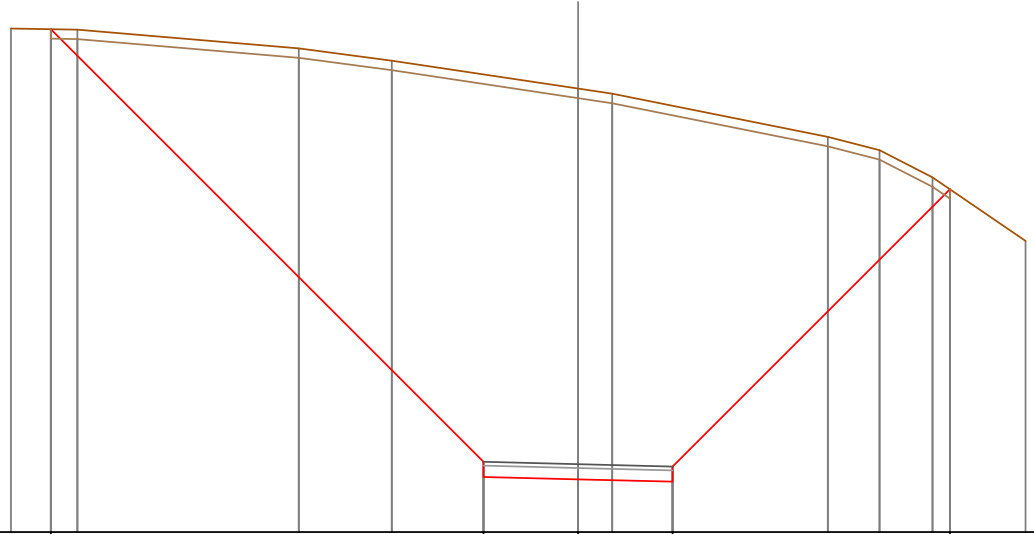

Scala H 1/200.00
 Scala V 1/200.00

380.00

Quote	380.30	381.46	381.40	381.33	380.07
Parziali		11.44	2.50	2.50	7.33
Sviluppata Par.		16.18	2.50	2.50	10.37
Sviluppata	0.00	-16.18	-18.69	-21.19	-31.56
Progressiva	-13.94	-2.50	0.00	2.50	9.83
Dislivelli	-0.00	-10.26	-10.33	-9.94	-0.00

Sezione: 92
 Progressiva: 470.000
 Q. Progetto: 380.167

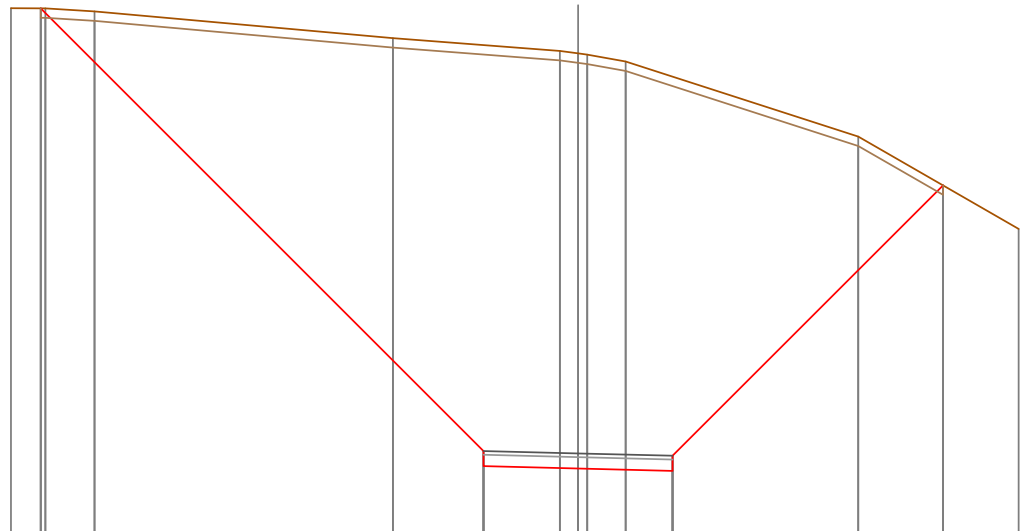

Scala H 1/200.00
 Scala V 1/200.00

378.00

Quote	378.94	379.83	379.77	379.70	377.26
Parziali		11.71	2.50	2.50	7.15
Sviluppata Par.		16.56	2.50	2.50	10.11
Sviluppata	0.00	-16.56	-19.06	-21.56	-31.67
Progressiva	-14.21	-2.50	0.00	2.50	9.65
Dislivelli	-0.00	-10.74	-10.88	-10.43	-0.00

Sezione: 93
 Progressiva: 471.874
 Q. Progetto: 379.768

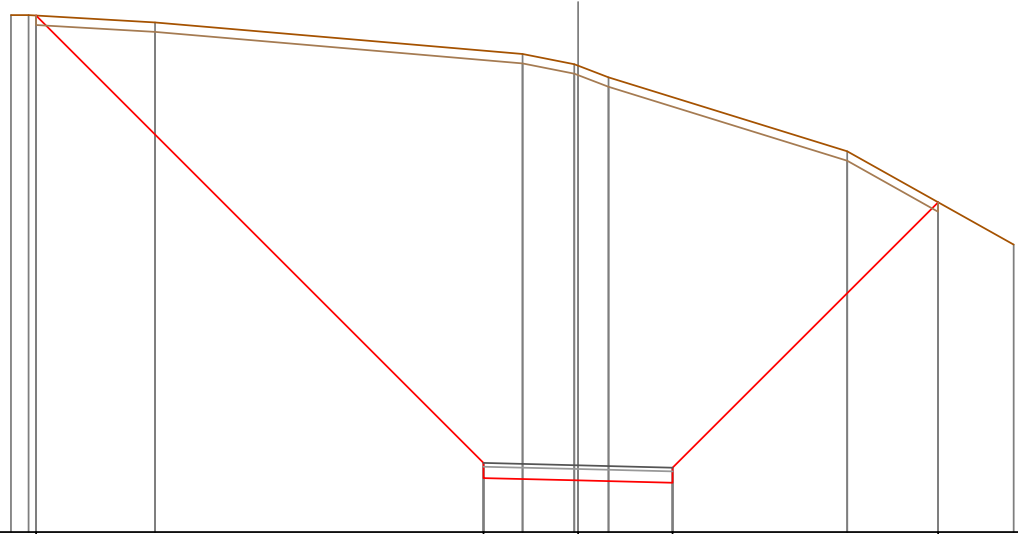

Scala H 1/200.00
 Scala V 1/200.00

378.00
 ▽

Quote	391.66	379.43	379.37	379.31	380.72
Parziali		11.83	2.50	2.50	7.02
Sviluppata Par.		16.74	2.50	2.50	9.93
Sviluppata	0.00	-16.74	-19.24	-21.74	-31.66
Progressiva	-14.33	-2.50	0.00	2.50	9.52
Dislivelli	0.00	-10.90	-10.97	-10.20	0.00

Sezione: 94
 Progressiva: 480.000
 Q. Progetto: 378.124

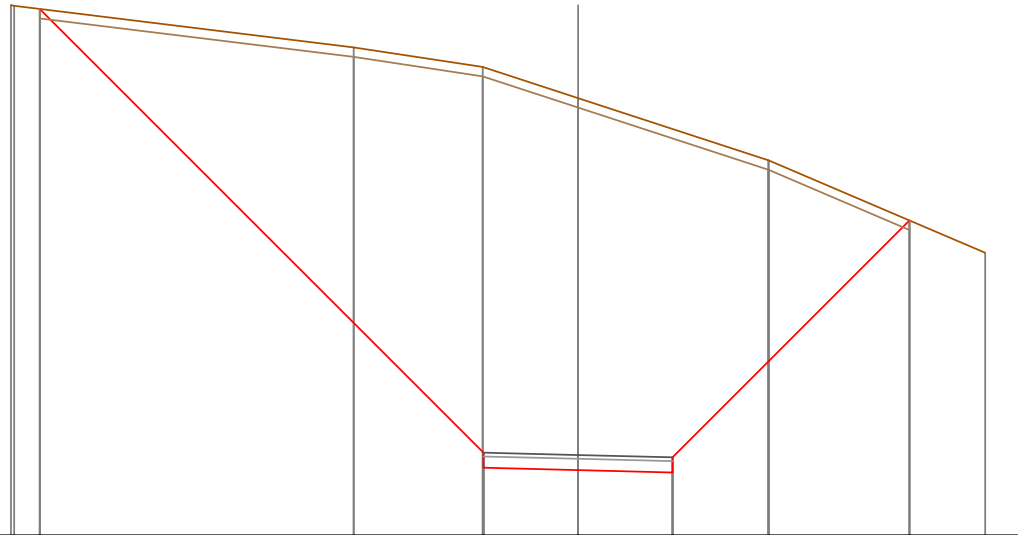

Scala H 1/200.00
 Scala V 1/200.00

376.00
 ▽

Quote	396.02	377.79	377.72	377.66	384.33
Parziali		11.74	2.50	2.50	6.27
Sviluppata Par.		16.60	2.50	2.50	8.86
Sviluppata	0.00	-16.60	-19.10	-21.60	-30.46
Progressiva	-14.24	-2.50	0.00	2.50	8.77
Dislivelli	0.00	-10.19	-9.84	-9.08	-0.00

Sezione: 95
 Progressiva: 481.357
 Q. Progetto: 377.863

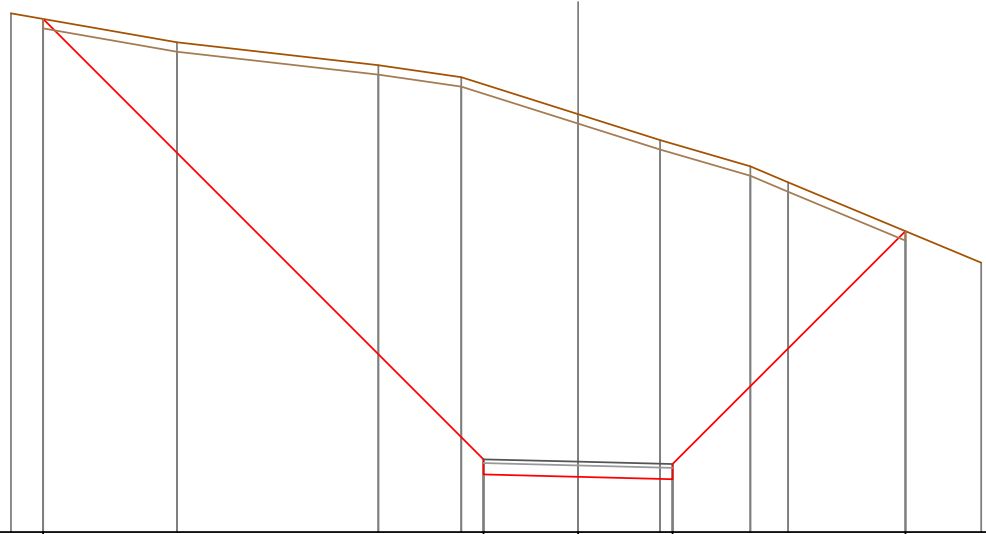

Scala H 1/200.00
 Scala V 1/200.00

376.00
 ▽

Quote		389.57		377.53	377.46	377.40		363.96
Parziali			11.65	2.50	2.50		6.16	
Sviluppata Par.			16.47	2.50	2.50		8.71	
Sviluppata	0.00			-16.47	-18.97	-21.47		-30.18
Progressiva	-14.15			-2.50	0.00	2.50		8.66
Dislivelli	0.00			-9.92	-9.59	-8.87		0.00

Sezione: 96
 Progressiva: 500.000
 Q. Progetto: 374.669

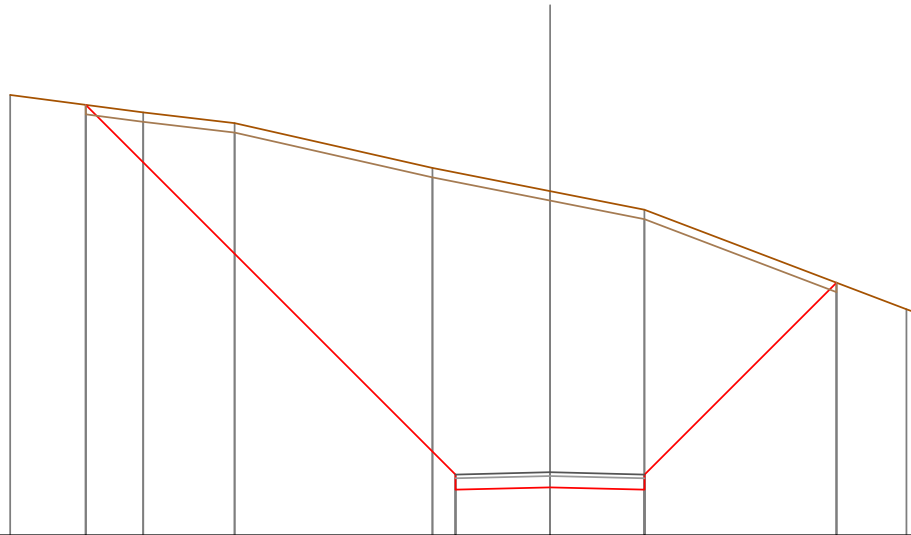

Scala H 1/200.00
 Scala V 1/200.00

373.00
 ▽

Quote		364.39		374.21	374.27	374.21		370.08
Parziali			9.78	2.50	2.50		5.07	
Sviluppata Par.			13.83	2.50	2.50		7.18	
Sviluppata	0.00			-13.83	-16.33	-18.83		-26.01
Progressiva	-12.28			-2.50	0.00	2.50		7.57
Dislivelli	0.00			-7.99	-7.83	-7.40		0.00

Sezione: 97
 Progressiva: 520.000
 Q. Progetto: 372.043

Scala H 1/200.00
 Scala V 1/200.00

370.00

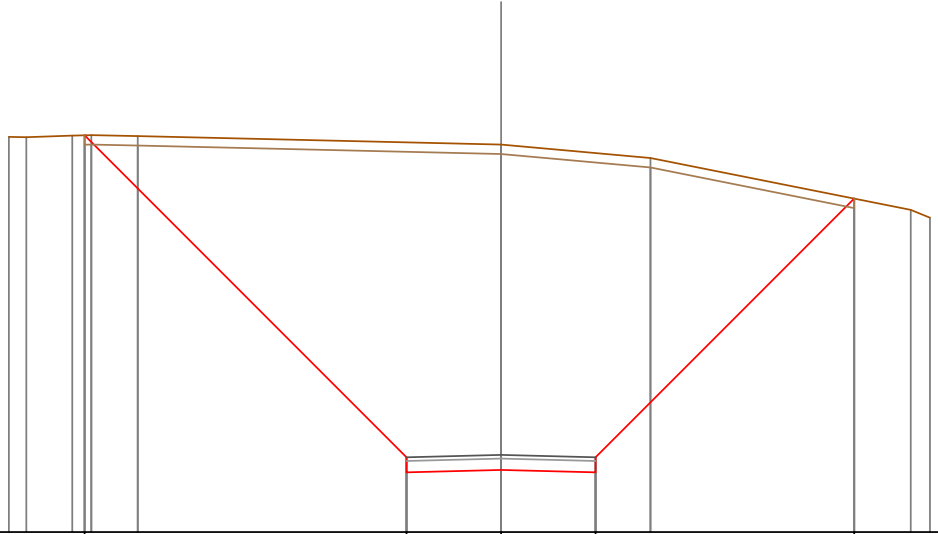



Quote	369.90	371.98	371.64	371.98	370.82
Parziali		8.52	2.50	2.50	6.84
Sviluppata Par.		12.04	2.50	2.50	9.67
Sviluppata	0.00	-12.04	-14.54	-17.05	-26.72
Progressiva	-11.02	-2.50	0.00	2.50	9.34
Dislivelli	0.00	-8.33	-8.61	-8.44	-0.00

Sezione: 98
 Progressiva: 540.000
 Q. Progetto: 370.232

Scala H 1/200.00
 Scala V 1/200.00

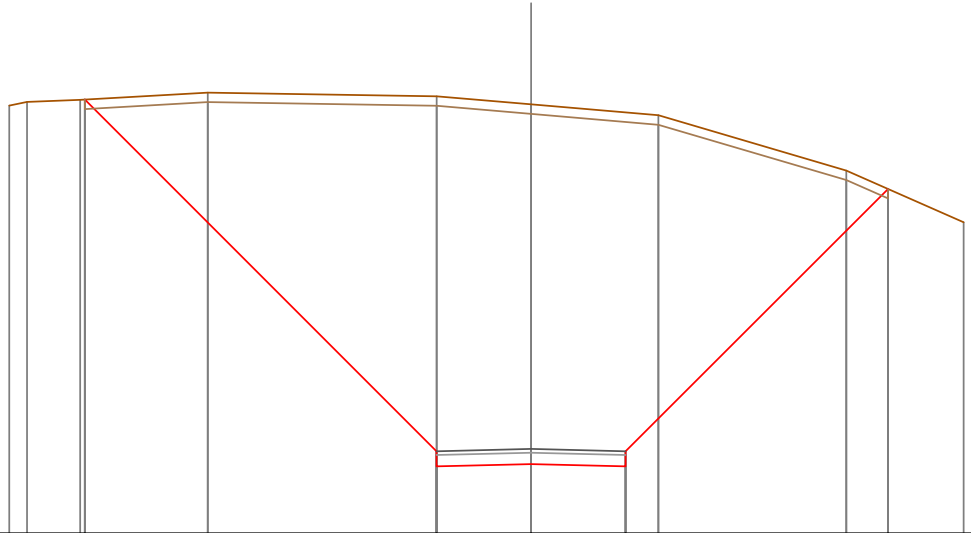
368.00

Quote	370.47	366.77	366.83	366.77	371.11
Parziali		9.30	2.50	2.50	6.94
Sviluppata Par.		13.16	2.50	2.50	9.81
Sviluppata	0.00	-13.16	-15.66	-18.16	-27.97
Progressiva	-11.50	-2.50	0.00	2.50	9.44
Dislivelli	0.00	-9.39	-9.51	-9.36	0.00

Sezione: 99
 Progressiva: 560.000
 Q. Progetto: 369.228

Scala H 1/200.00
 Scala V 1/200.00

367.00

Quote	371.60	366.77	366.83	366.77	372.91
Parziali	5.43	2.50	2.50	3.74	
Sviluppata Par.	7.68	2.50	2.50	5.29	
Sviluppata	-0.00	-7.93	0.00	-12.68	-17.98
Progressiva	-0.00	-2.50	0.00	2.50	6.24
Dislivelli	-0.00	-5.11	-5.08	-4.77	0.00

Sezione: 100
 Progressiva: 568.167
 Q. Progetto: 369.048

Scala H 1/200.00
 Scala V 1/200.00

367.00

Quote	372.77	366.59	366.65	366.71	371.17
Parziali	3.79	2.50	2.50	2.06	
Sviluppata Par.	5.36	2.50	2.50	2.92	
Sviluppata	-0.00	-6.29	0.00	-10.36	-13.28
Progressiva	-0.00	-3.48	-3.43	-2.88	0.00
Dislivelli	-0.00	-3.48	-3.43	-2.88	0.00

Sezione: 101
 Progressiva: 570.000
 Q. Progetto: 369.026

Scala H 1/200.00
 Scala V 1/200.00

367.00

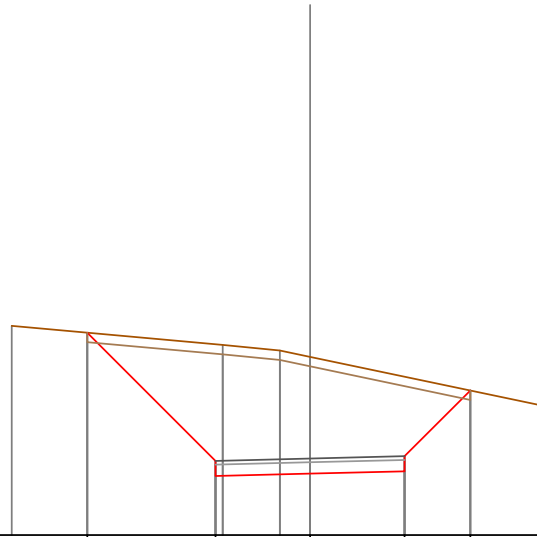

Quote		372.35	368.56	368.63	368.69	370.83
Parziali		3.39	2.50	2.50	1.74	
Sviluppata Par.		4.79	2.50	2.50	2.46	
Sviluppata		0.00	4.79	7.30	9.80	12.25
Progressiva		-5.89	-2.50	0.00	2.50	4.24
Dislivelli		0.00	-3.08	-3.09	-2.50	0.00

Sezione: 102
 Progressiva: 580.000
 Q. Progetto: 369.000

Scala H 1/200.00
 Scala V 1/200.00

367.00

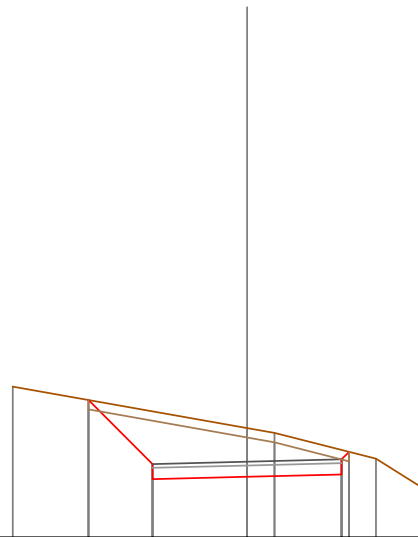

Quote		370.83	368.54	368.60	368.66	369.26
Parziali		1.70	2.50	2.50	0.90	
Sviluppata Par.		2.40	2.50	2.50	0.90	
Sviluppata		0.00	2.40	4.90	7.40	7.68
Progressiva		-4.20	-2.50	0.00	2.50	2.70
Dislivelli		0.00	-1.40	-1.29	-0.65	0.00

Sezione: 103
 Progressiva: 580.423
 Q. Progetto: 369.000

Scala H 1/200.00
 Scala V 1/200.00

367.00

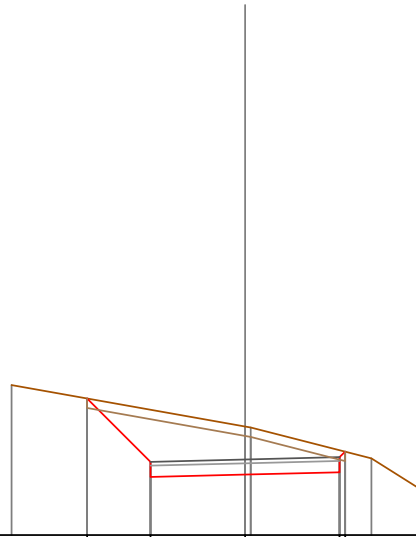

Quote	370.01	368.54	368.00	368.00	368.21
Parziali	1.68	2.50	2.50		
Sviluppata Par.	2.37	2.50	2.50		
Sviluppata	0.00	2.37	4.87	7.37	7.58
Progressiva	-4.18	-2.50	0.00	2.50	2.65
Dislivelli	0.00	-1.38	-1.27	-0.58	0.00

SEZIONI TRASVERSALI
Profilo longitudinale tratto 8-14
Viabilità di impianto-Postazione aerogeneratore VI04

Nota: Le canalette di deflusso delle acque meteoriche, non indicate nel presente elaborato, sono rappresentate graficamente nelle sezioni stradali tipo dell'elaborato "SR-VI-TC12_Piazzole aerogeneratori e strade di servizio - Particolari costruttivi", individuate planimetricamente nell'elaborato "SR-VI-TC13_Opere di regimazione acque superficiali - Planimetria generale" e quantificate nell'elaborato "SR-VI-RC6_Computo Metrico Estimativo opere civili".

DISEGNI DI RIFERIMENTO

TAVOLA	DESCRIZIONE
SR-VI-TC8.1	Piazzole e viabilità - Planimetria di progetto - Fase di cantiere
SR-VI-TC10	Profili longitudinali viabilità di impianto
SR-VI-TC12	Piazzole aerogeneratori e strade di servizio - Particolari costruttivi
SR-VI-TC13	Opere di regimazione acque superficiali - Planimetria generale

Sezione: 4
 Progressiva: 14.093
 Q. Progetto: 454.140

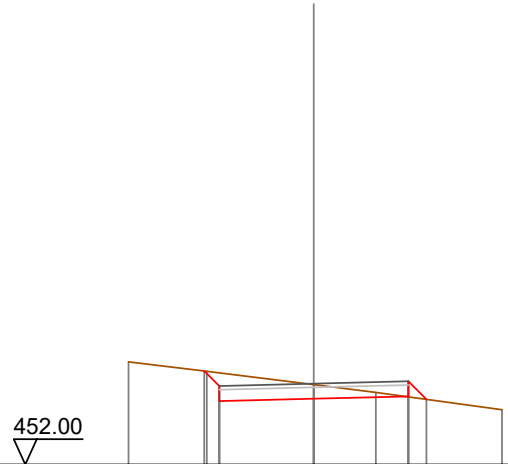

Quote Terreno		454.72		454.47		454.11		453.91		453.45
Quote Progetto			454.47	453.68		453.74		453.80	453.72	
Parziali			0.40	2.50		2.50		0.48		
Progressiva			-2.90	-2.50		0.00		2.50	2.98	
Dislivelli			0.00	-0.35		-0.37		0.01	0.00	

Sezione: 5
 Progressiva: 20.000
 Q. Progetto: 453.921

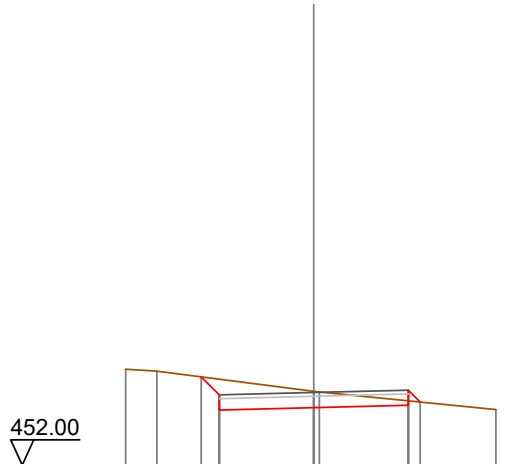

Quote Terreno		454.54		454.49		453.95		453.93		453.47
Quote Progetto			454.33	453.46		453.52		453.58	453.67	
Parziali			0.48	2.50		2.50		0.31		
Progressiva			-2.98	-2.50		0.00		2.50	2.81	
Dislivelli			0.00	-0.42		-0.43		-0.12	0.00	

Sezione: 6
 Progressiva: 30.000
 Q. Progetto: 453.394

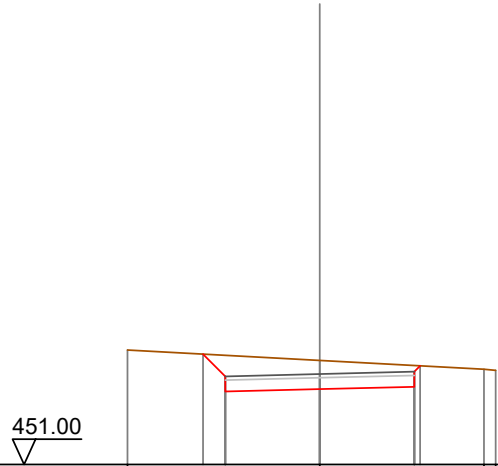

Quote Terreno	454.03		453.75		453.52	453.49
Quote Progetto		453.92	452.83	452.99	453.06	453.61
Parziali		0.59	2.50		2.50	
Progressiva		-3.09	-2.50	0.00	2.50	2.65
Dislivelli		0.00	-0.56	-0.76	-0.56	0.00

Sezione: 7
 Progressiva: 32.337
 Q. Progetto: 453.241

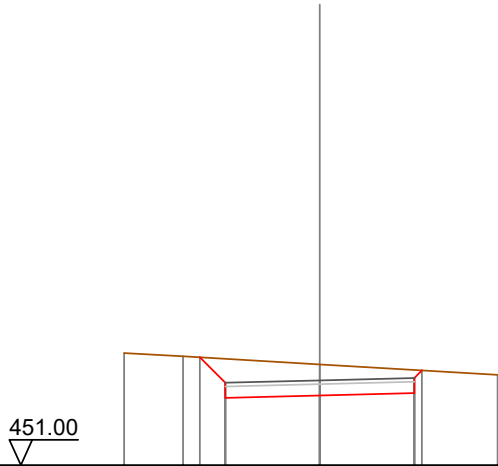

Quote Terreno	453.96	453.88		453.67		453.39
Quote Progetto		453.85	452.78	452.84	453.67	453.51
Parziali		0.67	2.50		2.50	
Progressiva		-3.17	-2.50	0.00	2.50	2.70
Dislivelli		0.00	-0.63	-0.82	-0.61	0.00

Sezione: 8
 Progressiva: 40.000
 Q. Progetto: 452.665

451.00

Quote Terreno		-453.33		-453.22		-452.98		-452.95		-452.95		-452.80
Quote Progetto			453.20	452.20		452.27		452.33		452.90		
Parziali			0.60	2.50		2.50						
Progressiva			-3.10	-2.50		0.00		2.50		2.67		
Dislivelli			-0.00	-0.55		-0.71		-0.58		0.00		

Sezione: 9
 Progressiva: 50.000
 Q. Progetto: 451.745

450.00

Quote Terreno		-452.04		-451.99		-451.72		-451.45		-451.42
Quote Progetto			451.92	451.28		451.35		451.41		451.53
Parziali				2.50		2.50		0.28		
Progressiva			-2.73	-2.50		0.00		2.50		2.78
Dislivelli			-0.00	-0.22		-0.38		-0.14		0.00

Sezione: 10
 Progressiva: 59.033
 Q. Progetto: 450.869

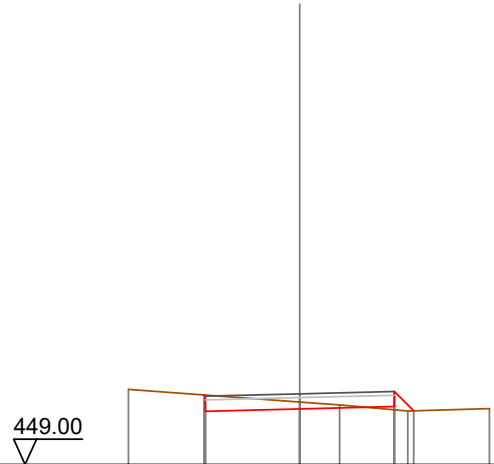

Quote Terreno		-450.98		-450.65	-450.58	-450.41	-450.48
Quote Progetto			450.84 450.41	450.47		450.53 450.42	
Parziali			2.50	2.50		0.51	
Progressiva			-2.53 -2.50	0.00		2.50 3.01	
Dislivelli			0.00 -0.03	-0.18		0.09 0.00	

Sezione: 11
 Progressiva: 60.000
 Q. Progetto: 450.772

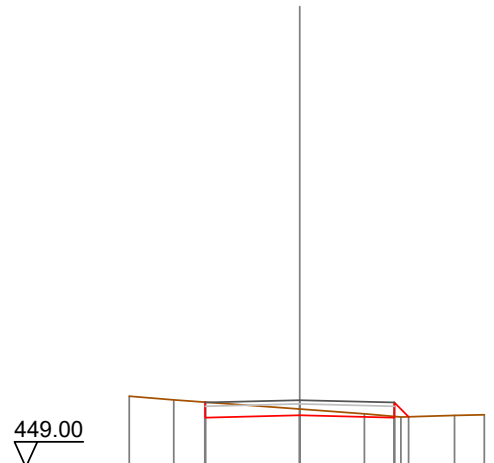

Quote Terreno		-450.87	-450.78	-450.54	-450.41	-450.32	-450.37	-450.38
Quote Progetto			450.31	450.37		450.31 450.33		
Parziali			2.50	2.50		0.38		
Progressiva			-2.51	0.00		2.50 2.88		
Dislivelli			0.00	-0.16		-0.03 -0.00		

Sezione: 12
 Progressiva: 68.061
 Q. Progetto: 449.883

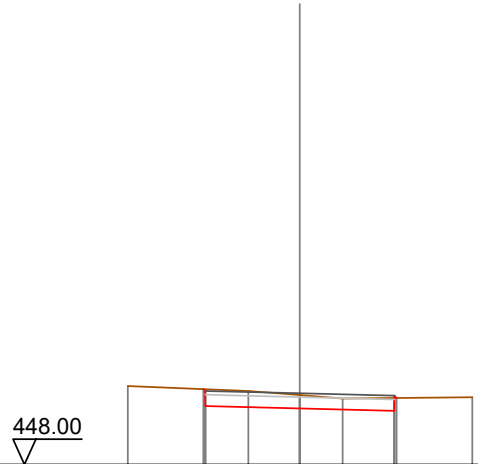

Quote Terreno	-450.07	-449.95	-449.84	-449.75	-449.78
Quote Progetto		449.99 449.55	449.48 449.84	449.42 449.76	
Parziali		2.50	2.50		
Progressiva		-2.55 -2.50	0.00	2.50 2.56	
Dislivelli		0.00 -0.05	-0.35	-0.34 0.00	

Sezione: 13
 Progressiva: 70.000
 Q. Progetto: 449.649

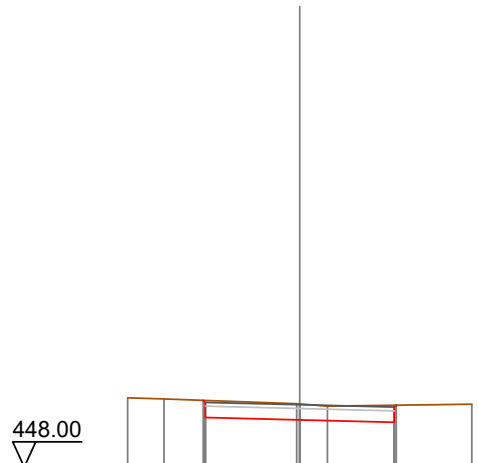

Quote Terreno	449.83	449.80	449.68	449.61	449.66
Quote Progetto		449.77 449.31	449.25 449.67	449.19 449.64	
Parziali		2.50	2.50		
Progressiva		-2.55 -2.50	0.00	2.50 2.55	
Dislivelli		0.00 -0.05	-0.42	-0.45 0.00	

Sezione: 14
 Progressiva: 76.626
 Q. Progetto: 448.793

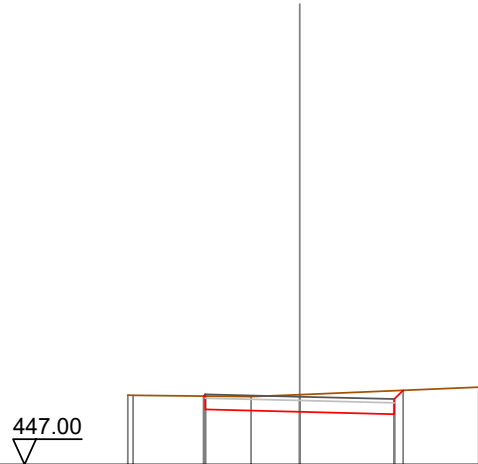

Quote Terreno	448.83	448.83		448.79	448.85		449.05
Quote Progetto			448.81	448.46	448.39	448.33	
Parziali				2.50	2.50		
Progressiva			-2.55	-2.50	0.00	2.50	2.73
Dislivelli			0.00	0.05	-0.45	-0.62	0.00

Sezione: 15
 Progressiva: 80.000
 Q. Progetto: 448.322

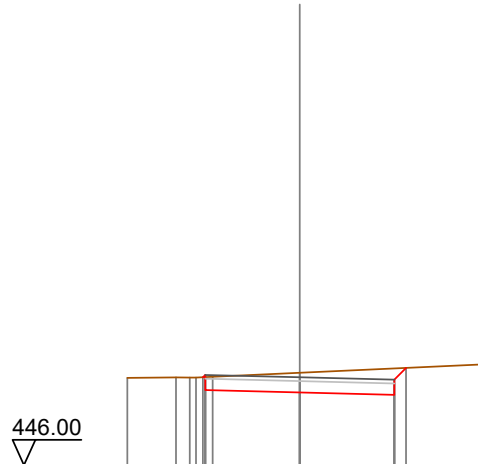

Quote Terreno	448.31	448.32	448.31	448.34	448.44		448.66
Quote Progetto		448.32	447.98		447.92	447.86	
Parziali				2.50	2.50	0.31	
Progressiva		-2.56	-2.50		0.00	2.50	2.81
Dislivelli		0.00	0.06		-0.52	-0.70	-0.00

Sezione: 16
 Progressiva: 85.191
 Q. Progetto: 447.553

446.00

Quote Terreno		447.30		447.54		447.64				448.05
Quote Progetto			447.44	447.22		447.15		447.09	447.88	
Parziali				2.50		2.50		0.39		
Progressiva			-2.68	-2.50		0.00		2.50	2.89	
Dislivelli			0.00	0.16		-0.49		-0.76	0.00	

Sezione: 17
 Progressiva: 100.000
 Q. Progetto: 445.251

443.00

Quote Terreno		444.52		444.71		444.85		445.17		445.91	445.99
Quote Progetto			444.69	444.79		444.85		444.79	445.66		
Parziali			0.50	2.50		2.50		0.47			
Progressiva			-3.00	-2.50		0.00		2.50	2.97		
Dislivelli			-0.00	0.43		-0.32		-0.80	-0.00		

Sezione: 18
 Progressiva: 120.119
 Q. Progetto: 442.520

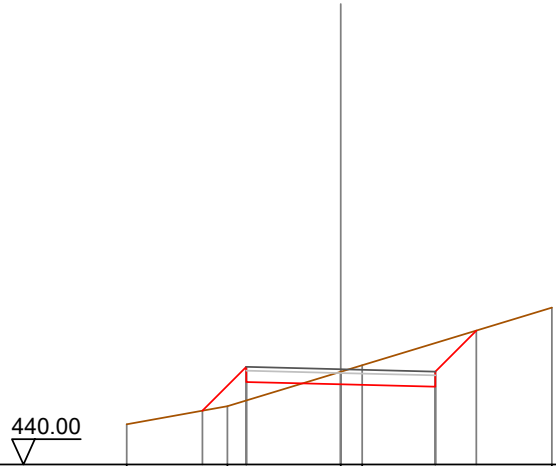

Quote Terreno		-441.06		-441.54		-442.45		-442.62		-444.15
Quote Progetto			441.42	442.18		442.12		442.06	443.54	
Parziali			1.16	2.50		2.50		1.08		
Progressiva			-3.66	-2.50		0.00		2.50	3.58	
Dislivelli			-0.00	0.89		-0.33		-1.15	0.00	

Sezione: 19
 Progressiva: 123.236
 Q. Progetto: 442.171

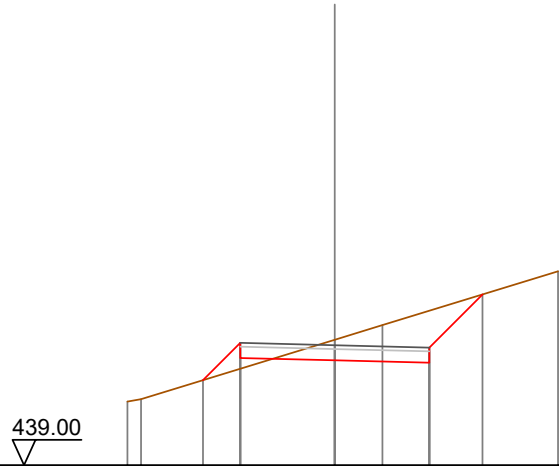

Quote Terreno		-440.68		-440.75		-442.32		-442.70		-444.13
Quote Progetto			441.25	441.83		441.77		441.71	443.52	
Parziali			0.98	2.50		2.50		1.41		
Progressiva			-3.48	-2.50		0.00		2.50	3.91	
Dislivelli			0.00	0.68		-0.55		-1.37	0.00	

Sezione: 20
 Progressiva: 126.353
 Q. Progetto: 441.842

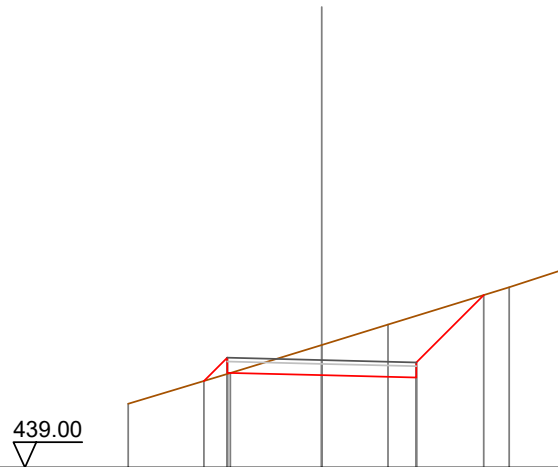

Quote Terreno		440.69		441.50		442.24		442.78		443.77		444.20
Quote Progetto			441.29	441.50		441.44		441.38		443.56		
Parziali			0.62	2.50		2.50		1.78				
Progressiva			-3.12	-2.50		0.00		2.50		4.28		
Dislivelli			0.00	0.43		-0.80		-1.63		0.00		

Sezione: 21
 Progressiva: 140.000
 Q. Progetto: 440.600

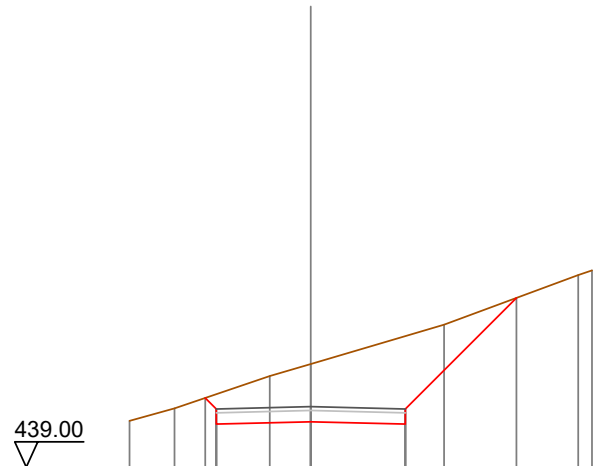

Quote Terreno		440.22		440.55		441.41		441.73		442.77		444.08	444.20
Quote Progetto			440.83	440.14		440.20		440.14		443.47			
Parziali			0.28	2.50		2.50		2.94					
Progressiva			-2.79	-2.50		0.00		2.50		5.44			
Dislivelli			0.00	-0.39		-1.53		-2.33		0.00			

Sezione: 22
 Progressiva: 160.000
 Q. Progetto: 438.600

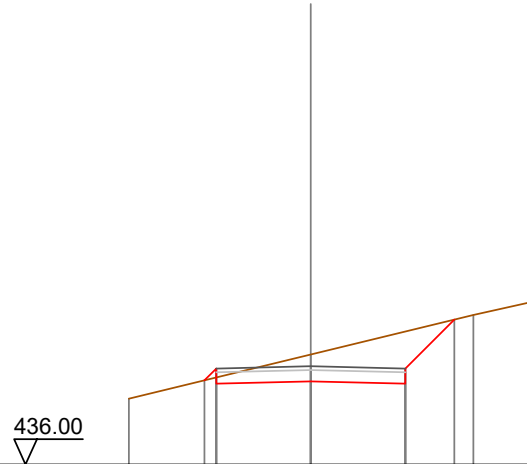

Quote Terreno	-437.74			438.91					
Quote Progetto		438.23	438.14	438.20	438.14	439.83			
Parziali		0.31	2.50	2.50	1.30				
Progressiva		-2.81	-2.50	0.00	2.50	3.80			
Dislivelli		0.00	0.24	-0.71	-1.38	-0.00			

Sezione: 23
 Progressiva: 168.141
 Q. Progetto: 437.559

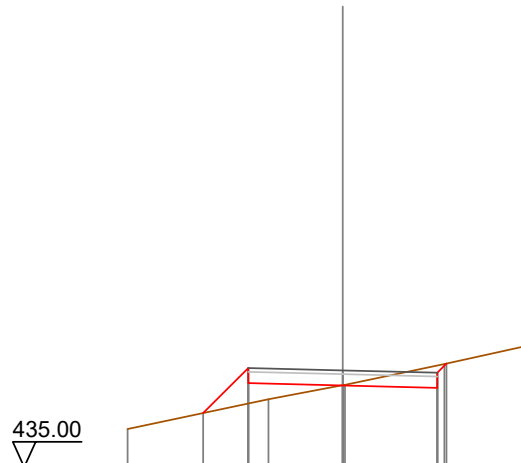

Quote Terreno	-436.01			437.17					
Quote Progetto		436.43	437.22	437.16	437.18	437.10			
Parziali		1.19	2.50	2.50					
Progressiva		-3.69	-2.50	0.00	2.50	2.74			
Dislivelli		0.00	0.94	-0.01	-0.59	0.00			

Sezione: 24
 Progressiva: 170.000
 Q. Progetto: 437.302

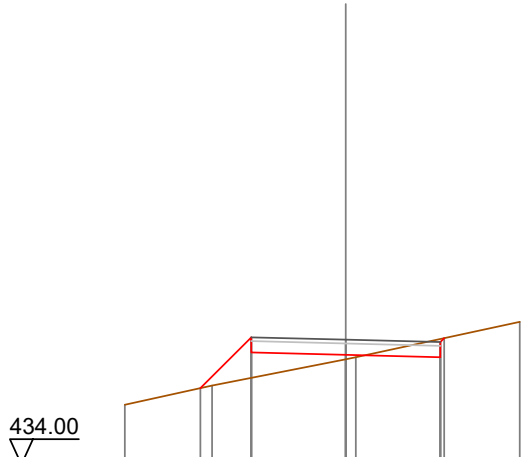

Quote Terreno		435.58	436.09	436.78	436.84	437.77
Quote Progetto			436.02	436.96	436.90	436.84
Parziali			1.34	2.50	2.50	
Progressiva			-3.84	-2.50	0.00	2.50
Dislivelli			0.00	1.07	0.12	-0.48
						0.00

Sezione: 25
 Progressiva: 180.175
 Q. Progetto: 435.772

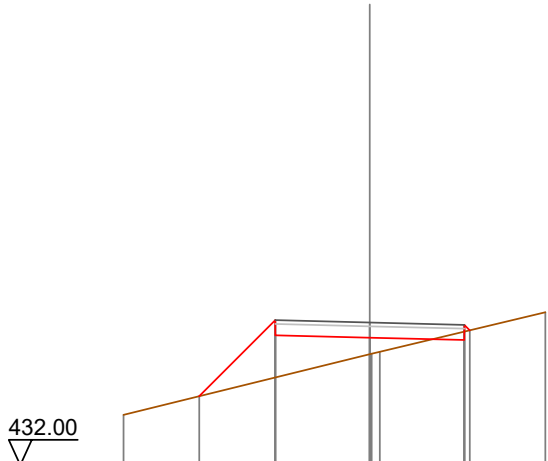

Quote Terreno		433.33	434.94	435.00	436.04
Quote Progetto			433.82	435.43	435.31
Parziali			2.01	2.50	2.50
Progressiva			-4.51	-2.50	0.00
Dislivelli			0.00	1.51	0.44
					-0.22
					0.00

Sezione: 26
 Progressiva: 190.000
 Q. Progetto: 434.290

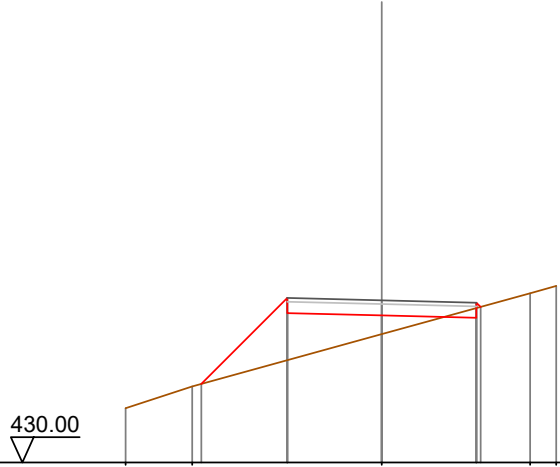

Quote Terreno		-431.44	-432.01		-433.39		-434.48	-434.67
Quote Progetto			432.08	433.95	433.89	433.83	434.11	
Parziali			2.27	2.50	2.50			
Progressiva			-4.77	-2.50	0.00	2.50	2.61	
Dislivelli			0.00	1.65	0.50	-0.26	0.00	

Sezione: 27
 Progressiva: 192.210
 Q. Progetto: 433.984

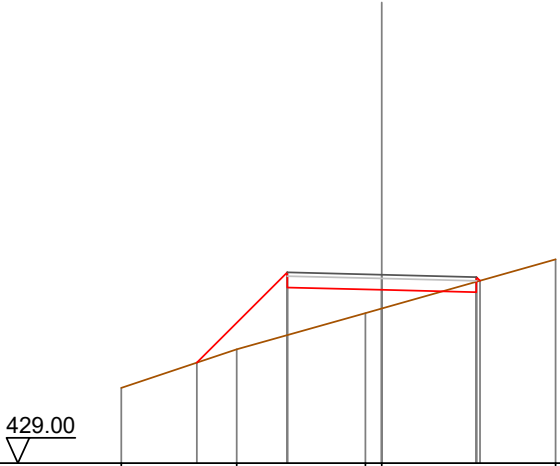

Quote Terreno		-430.99	-432.01		-432.97		-434.39
Quote Progetto			431.66	433.65	433.58	433.52	
Parziali			2.39	2.50	2.50		
Progressiva			-4.89	-2.50	0.00	2.50	2.60
Dislivelli			0.00	1.66	0.49	-0.28	0.00

Sezione: 28
 Progressiva: 197.021
 Q. Progetto: 433.351

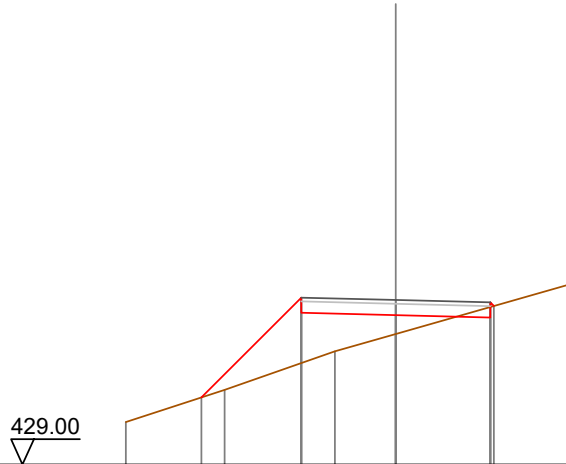

Quote Terreno	-430.12	-430.97	-431.99	-432.45	-433.77
Quote Progetto		430.77	433.01	432.95	432.89 433.19
Parziali		2.64	2.50	2.50	
Progressiva		-5.14	-2.50	0.00	2.50 2.59
Dislivelli		-0.00	1.73	0.50	-0.28 -0.00

Sezione: 29
 Progressiva: 200.000
 Q. Progetto: 432.983

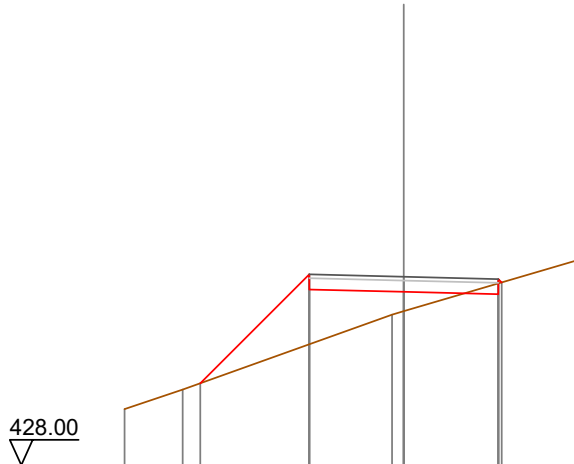

Quote Terreno	-429.48	-430.00	-431.98	-432.07	-433.42
Quote Progetto		430.16	432.65	432.58	432.52 432.83
Parziali		2.88	2.50	2.50	
Progressiva		-5.38	-2.50	0.00	2.50 2.59
Dislivelli		0.00	1.85	0.51	-0.29 0.00

Sezione: 30
 Progressiva: 210.000
 Q. Progetto: 431.881

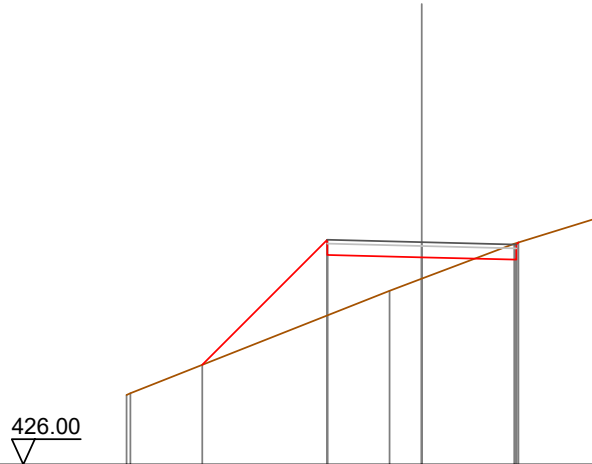

Quote Terreno		427.84	427.89				430.59	430.92	431.84	432.49
Quote Progetto				428.64		431.54			431.42	431.87
Parziali					3.31		2.50		2.50	
Progressiva				-5.81		-2.50		0.00	2.50	2.56
Dislivelli				0.00		2.00		0.56	-0.44	0.00

Sezione: 31
 Progressiva: 214.983
 Q. Progetto: 431.407

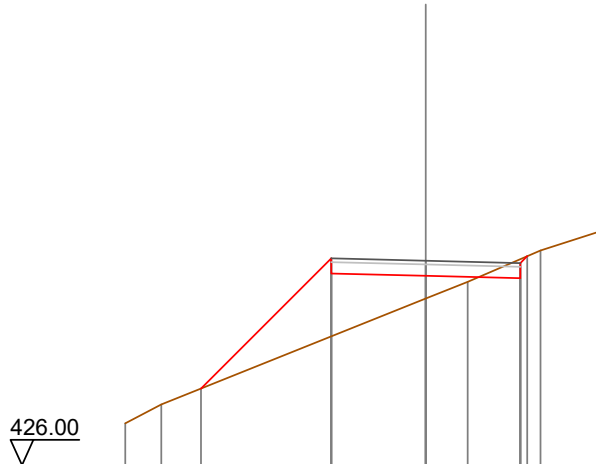

Quote Terreno		427.11	427.60				430.41	430.85	431.68	432.20
Quote Progetto				428.02		431.07		431.01	430.94	431.53
Parziali					3.45		2.50		2.50	
Progressiva				-5.95		-2.50		0.00	2.50	2.68
Dislivelli				0.00		2.07		0.60	-0.50	-0.00

Sezione: 32
 Progressiva: 220.000
 Q. Progetto: 430.972

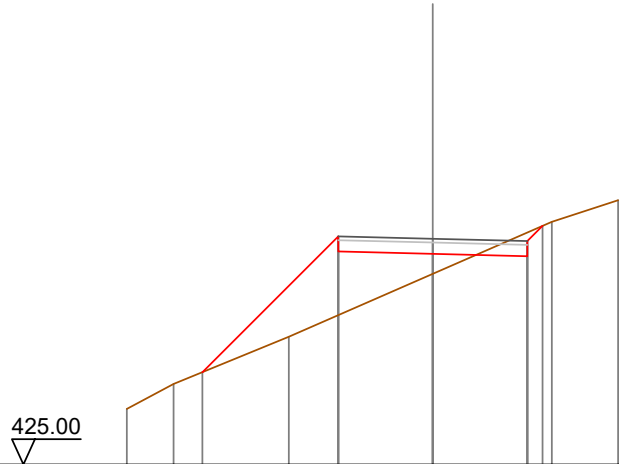

Quote Terreno		426.47	427.13	428.38	430.04	430.51	431.42	431.99
Quote Progetto			427.44		430.63	430.57	430.51	431.31
Parziali				3.59	2.50	2.50	0.40	
Progressiva			-6.09		-2.50	0.00	2.50	2.90
Dislivelli			0.00		2.08	0.53	-0.63	0.00

Sezione: 33
 Progressiva: 230.000
 Q. Progetto: 430.111

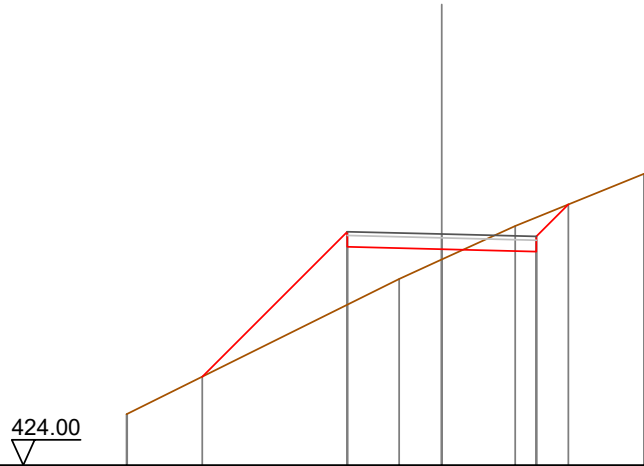

Quote Terreno		425.34			428.92	429.44	430.33	431.71
Quote Progetto			426.34		429.77	429.71	429.65	430.90
Parziali				3.84	2.50	2.50	0.85	
Progressiva			-6.34		-2.50	0.00	2.50	3.35
Dislivelli			0.00		1.93	0.27	-0.90	0.00

Sezione: 34
 Progressiva: 232.945
 Q. Progetto: 429.858

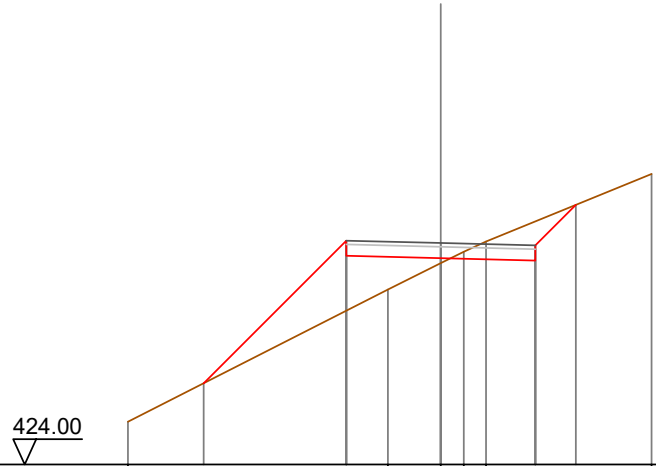

Quote Terreno		425.13				428.63	429.33	429.63	429.90		431.68
Quote Progetto			426.15		429.52		429.46		429.40	430.87	
Parziali				3.77		2.50		2.50		1.07	
Progressiva			-6.27		-2.50		0.00		2.50	3.57	
Dislivelli			0.00		1.85		0.13		-1.04	-0.00	

Sezione: 35
 Progressiva: 240.000
 Q. Progetto: 429.227

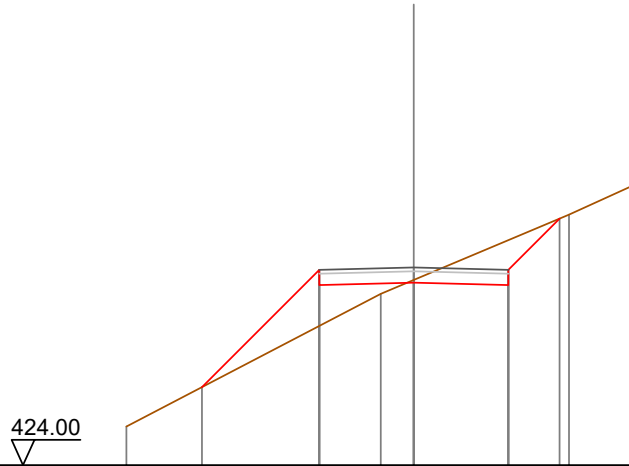

Quote Terreno		425.02				428.53	428.90			430.63	431.42
Quote Progetto			426.06		428.76		428.83		428.76	430.52	
Parziali				3.10		2.50		2.50		1.35	
Progressiva			-5.60		-2.50		0.00		2.50	3.85	
Dislivelli			0.00		1.48		-0.07		-1.18	0.00	

Sezione: 36
 Progressiva: 240.981
 Q. Progetto: 429.132

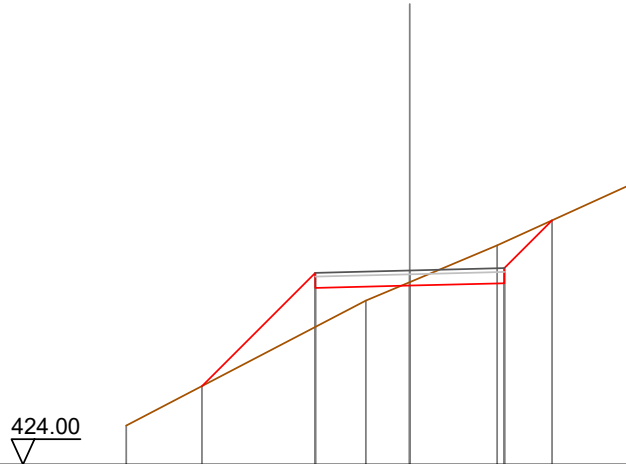

Quote Terreno		-425.03			-428.34	-428.82	-429.80		-431.37
Quote Progetto			426.07		428.67	428.73	428.79	430.46	
Parziali				3.00	2.50	2.50	1.26		
Progressiva			-5.50		-2.50	0.00	2.50	3.76	
Dislivelli			-0.00		1.43	-0.09	-1.09	0.00	

Sezione: 37
 Progressiva: 242.402
 Q. Progetto: 428.991

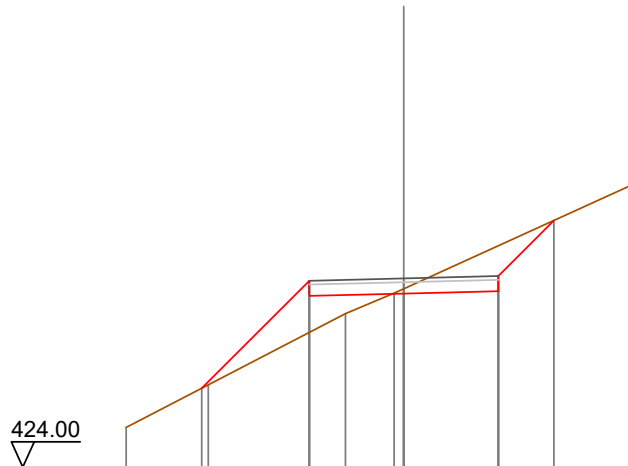

Quote Terreno		-425.05			-428.06	-428.60	-428.72		-431.43
Quote Progetto			426.09		428.53	428.59	428.65	430.52	
Parziali				2.84	2.50	2.50	1.47		
Progressiva			-5.34		-2.50	0.00	2.50	3.97	
Dislivelli			0.00		1.36	-0.13	-1.20	-0.00	

Sezione: 38
 Progressiva: 243.823
 Q. Progetto: 428.846

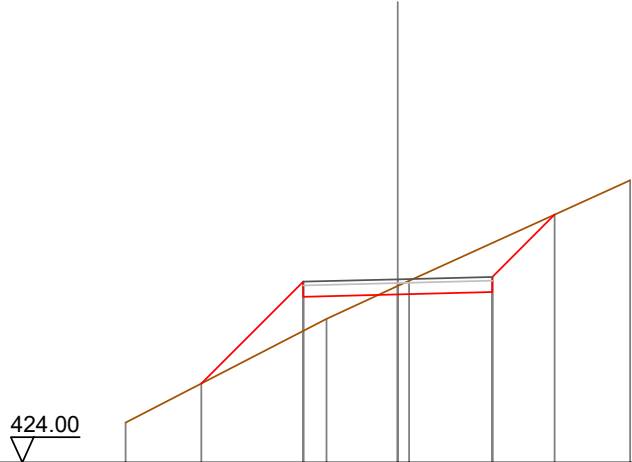

Quote Terreno		425.05		427.80	428.67	428.81		431.46
Quote Progetto			426.09	428.38	428.45	428.51	430.56	
Parziali			2.70	2.50	2.50	1.65		
Progressiva			-5.20	-2.50	0.00	2.50	4.15	
Dislivelli			0.00	1.31	-0.22	-1.30	-0.00	

Sezione: 39
 Progressiva: 251.107
 Q. Progetto: 428.037

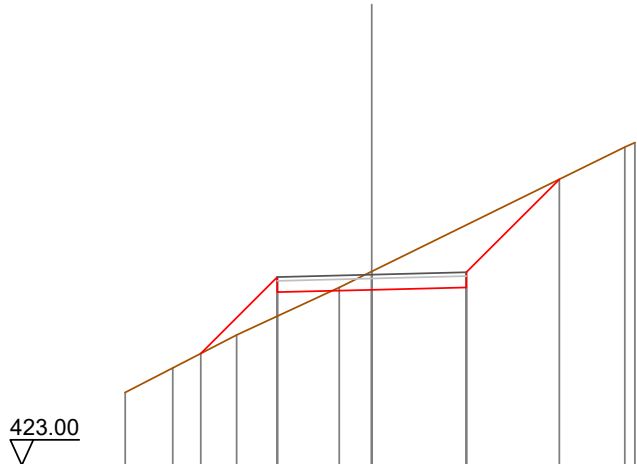

Quote Terreno		424.92	425.57	426.44	427.70	428.12		431.41
Quote Progetto			425.95	427.57	427.64	427.70	430.56	
Parziali			2.02	2.50	2.50	2.46		
Progressiva			-4.52	-2.50	0.00	2.50	4.96	
Dislivelli			-0.00	1.04	-0.49	-1.66	0.00	

Sezione: 40
 Progressiva: 260.000
 Q. Progetto: 426.903

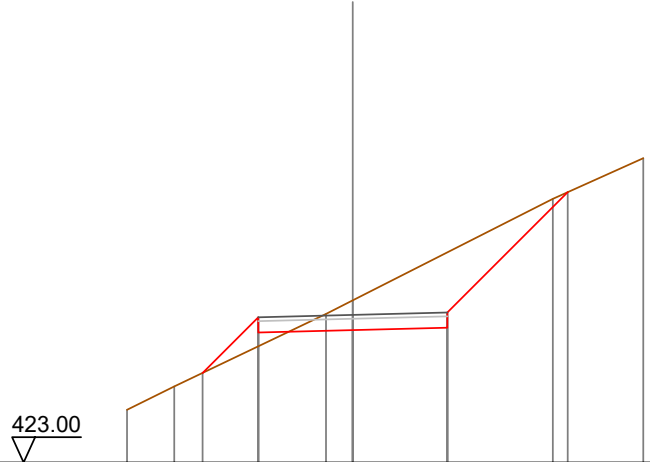

Quote Terreno		-424.39	-425.01		-426.93	-427.29		-429.97	-431.05
Quote Progetto			425.37	426.44	426.50	426.57	430.15		
Parziali				1.47	2.50	2.50	3.18		
Progressiva			-3.97	-2.50	0.00	2.50	5.68		
Dislivelli			0.00	0.77	-0.79	-1.99	0.00		

Sezione: 41
 Progressiva: 270.000
 Q. Progetto: 425.434

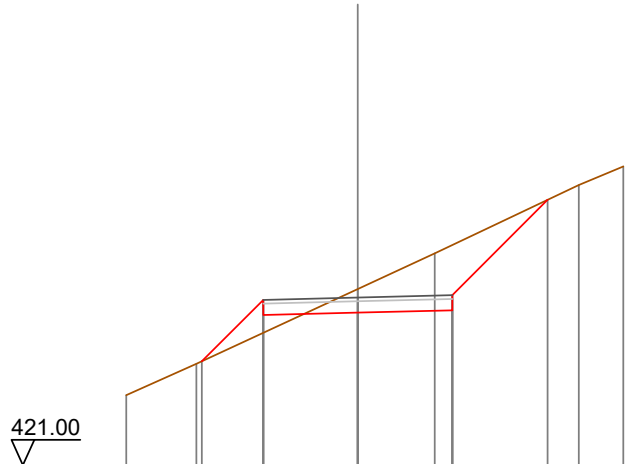

Quote Terreno		-422.85	-423.68		-425.66	-426.60		-428.41	-428.90
Quote Progetto			423.75	424.97	425.03	425.10	428.02		
Parziali				1.62	2.50	2.50	2.52		
Progressiva			-4.12	-2.50	0.00	2.50	5.02		
Dislivelli			-0.00	0.87	-0.63	-1.73	0.00		

Sezione: 42
 Progressiva: 274.945
 Q. Progetto: 424.658

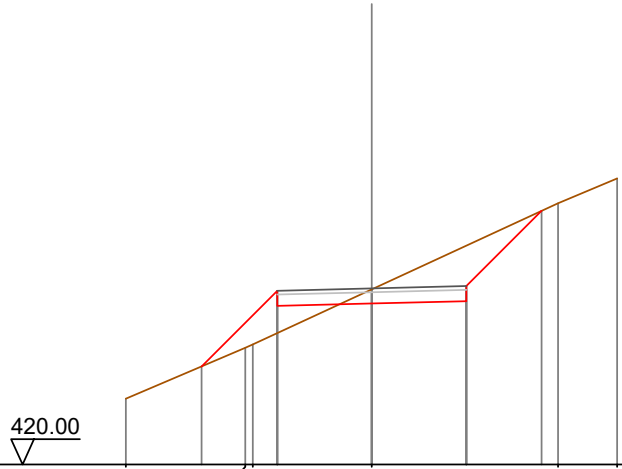

Quote Terreno		-421.74		-423.09 -423.17		-424.63		-426.91	-427.56
Quote Progetto			422.59		424.20		424.26	424.32	426.71
Parziali				2.00	2.50		2.50	1.99	
Progressiva			-4.50		-2.50		0.00	2.50	4.49
Dislivelli			-0.00		1.12		-0.37	-1.47	0.00

Sezione: 43
 Progressiva: 280.000
 Q. Progetto: 423.869

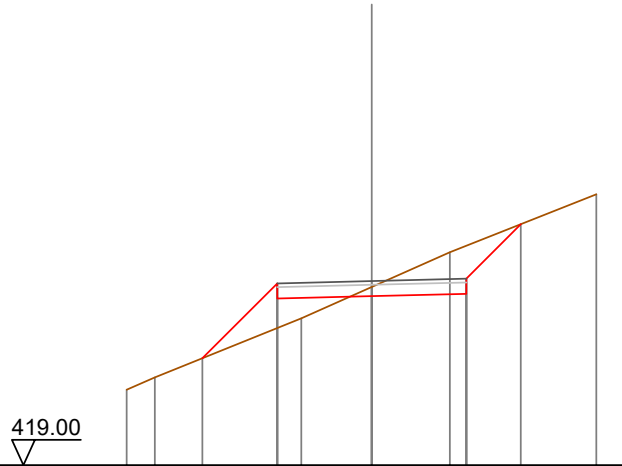

Quote Terreno		-420.99		-421.32		-422.88		-424.63	-426.16
Quote Progetto			421.83		423.41		423.47	423.53	425.37
Parziali				1.98	2.50		2.50	1.44	
Progressiva			-4.48		-2.50		0.00	2.50	3.94
Dislivelli			0.00		1.18		-0.24	-1.27	0.00

Sezione: 44
 Progressiva: 290.000
 Q. Progetto: 422.446

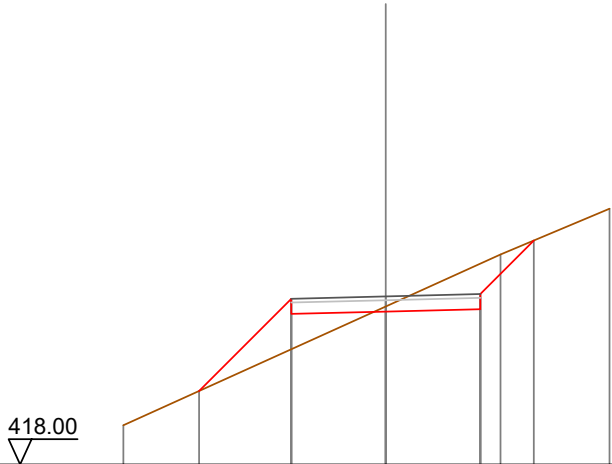

Quote Terreno		-419.04				422.18		423.55		424.76
Quote Progetto			419.95		421.98		422.05		422.11	423.92
Parziali				2.44		2.50		2.50		1.42
Progressiva			-4.94		-2.50		0.00		2.50	3.92
Dislivelli			0.00		1.33		-0.13		-1.20	0.00

Sezione: 45
 Progressiva: 298.783
 Q. Progetto: 421.365

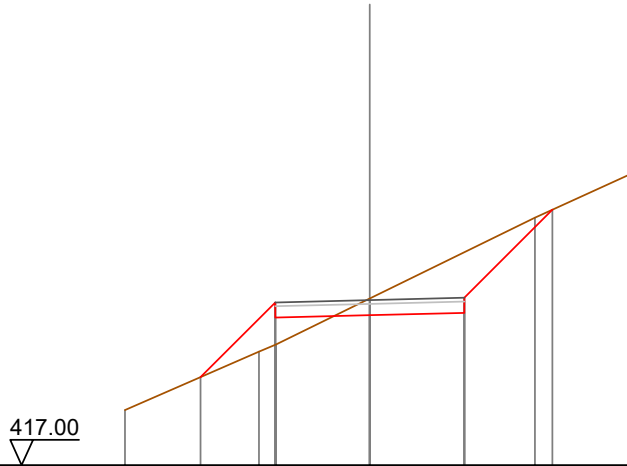

Quote Terreno		-418.46				421.41		423.55		424.67
Quote Progetto			419.33		420.90		420.96		421.03	423.76
Parziali				1.97		2.50		2.50		2.33
Progressiva			-4.47		-2.50		0.00		2.50	4.83
Dislivelli			-0.00		1.12		-0.44		-1.60	0.00

Sezione: 46
 Progressiva: 299.501
 Q. Progetto: 421.284

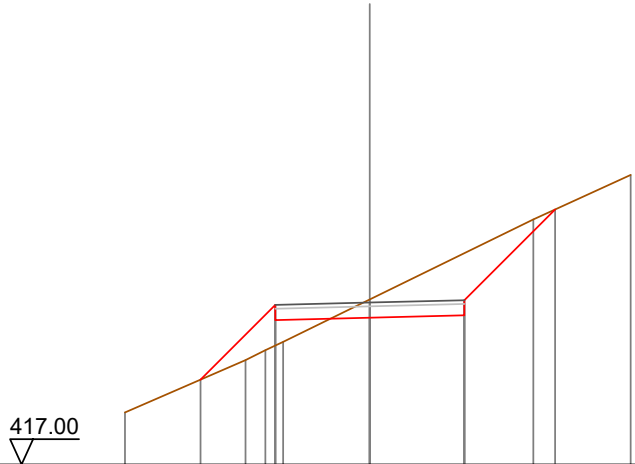

Quote Terreno		418.38		419.76	420.02	420.24		421.37		423.48	424.66
Quote Progetto			419.25		420.82			420.88	420.95	423.75	
Parziali				1.98	2.50			2.50	2.40		
Progressiva			-4.48		-2.50			0.00	2.50	4.90	
Dislivelli			0.00	1.07			-0.48		-1.64	-0.00	

Sezione: 47
 Progressiva: 300.000
 Q. Progetto: 421.228

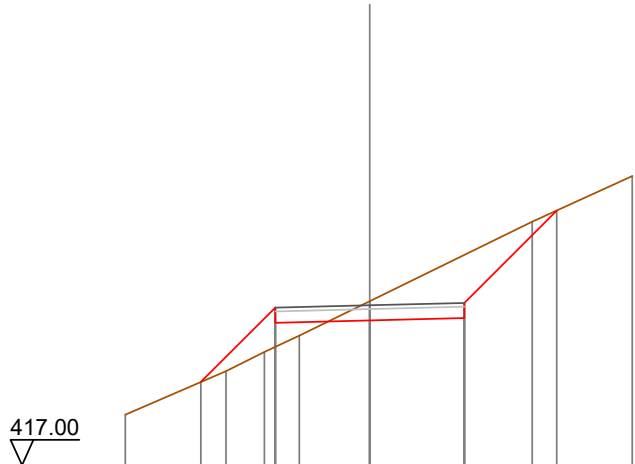

Quote Terreno		418.33		419.49	419.99	420.42		421.34		423.44	424.64
Quote Progetto			419.20		420.77			420.83	420.89	423.73	
Parziali				1.97	2.50			2.50	2.44		
Progressiva			-4.47		-2.50			0.00	2.50	4.94	
Dislivelli			0.00	1.04			-0.51		-1.67	0.00	

Sezione: 48
 Progressiva: 308.759
 Q. Progetto: 420.289

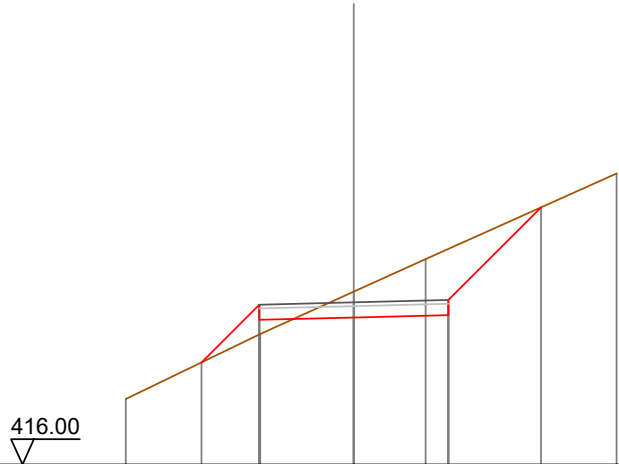

Quote Terreno		-417.73		419.45		420.57		-421.43		-423.70
Quote Progetto			418.70	419.83		419.89		419.95		422.80
Parziali				1.53		2.50		2.50		2.45
Progressiva			-4.03	-2.50		0.00		2.50		4.95
Dislivelli			0.00	0.79		-0.68		-1.75		-0.00

Sezione: 49
 Progressiva: 310.000
 Q. Progetto: 420.157

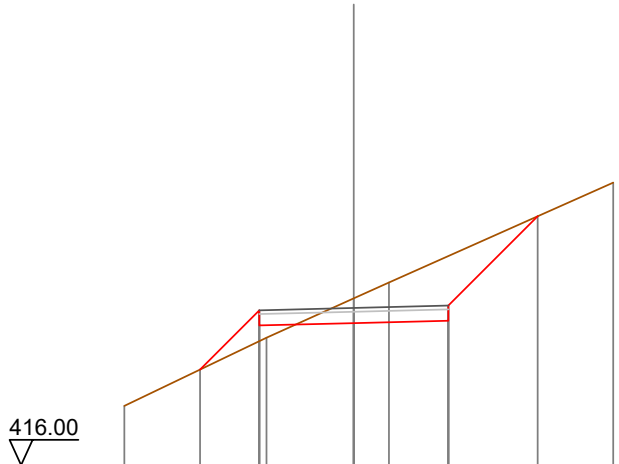

Quote Terreno		-417.57		419.37		420.41		-420.83		-423.47
Quote Progetto			418.53	419.69		419.76		419.82		422.58
Parziali				1.57		2.50		2.50		2.36
Progressiva			-4.07	-2.50		0.00		2.50		4.86
Dislivelli			0.00	0.81		-0.65		-1.71		0.00

Sezione: 50
 Progressiva: 318.017
 Q. Progetto: 419.334

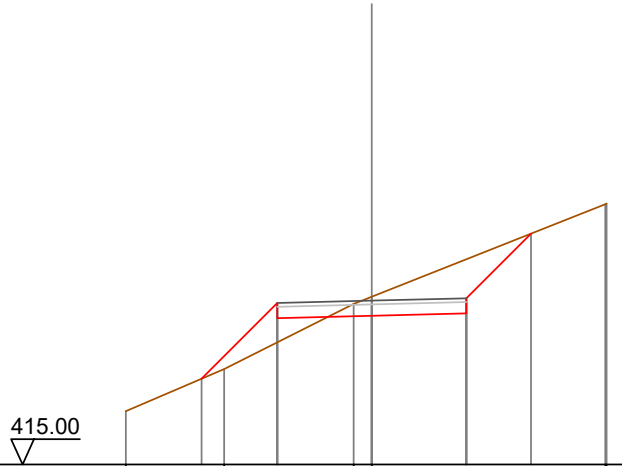

Quote Terreno		416.41	417.53	418.87	419.25	419.44		421.89	421.90
Quote Progetto			417.27	418.87	418.83	419.44	419.00	421.11	
Parziali			2.00	2.50	2.50	1.71			
Progressiva			-4.50	-2.50	0.00	2.50	4.21		
Dislivelli			0.00	1.04	-0.50	-1.43	-0.00		

Sezione: 51
 Progressiva: 320.000
 Q. Progetto: 419.149

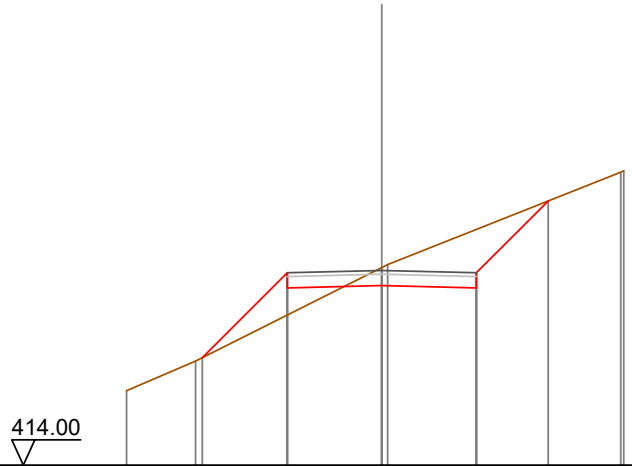

Quote Terreno		415.97	416.75		419.23	419.30		421.75	421.79
Quote Progetto			416.84	418.69	418.75	419.30	418.69	420.99	
Parziali			2.25	2.50	2.50	1.90			
Progressiva			-4.75	-2.50	0.00	2.50	4.40		
Dislivelli			0.00	1.12	-0.48	-1.55	0.00		

Sezione: 52
 Progressiva: 320.237
 Q. Progetto: 419.128

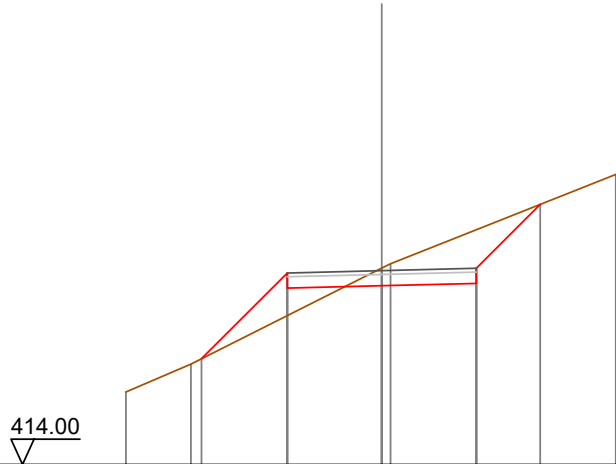

Quote Terreno	415.92	416.66	418.67	419.19	419.31	421.67
Quote Progetto		416.80	418.67	418.73	418.79	420.88
Parziali			2.27	2.50	2.50	1.69
Progressiva		-4.77	-2.50	0.00	2.50	4.19
Dislivelli		-0.00	1.13	-0.47	-1.42	-0.00

Sezione: 53
 Progressiva: 330.000
 Q. Progetto: 418.337

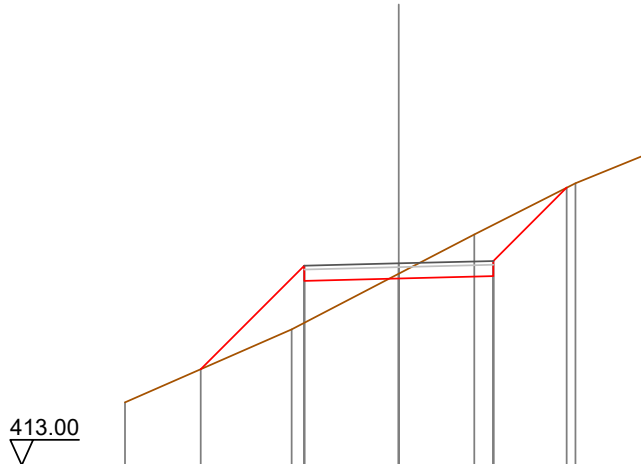

Quote Terreno	414.66	416.59	418.06	419.10	420.46	421.18
Quote Progetto		415.54	417.87	417.94	418.00	420.34
Parziali		2.74	2.50	2.50	1.94	
Progressiva		-5.24	-2.50	0.00	2.50	4.44
Dislivelli		-0.00	1.51	-0.13	-1.36	-0.00

Sezione: 54
 Progressiva: 334.572
 Q. Progetto: 418.033

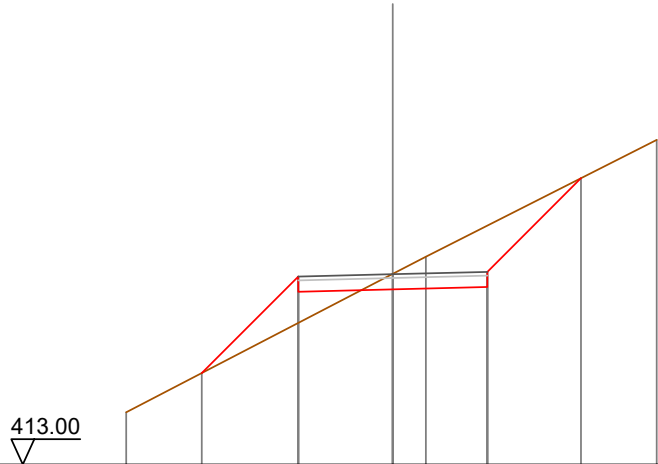

Quote Terreno		-414.38			418.04	-418.50				-421.59
Quote Progetto			415.42	417.57	417.63	417.70	420.57			
Parziali			2.55	2.50	2.50	2.48				
Progressiva			-5.05	-2.50	0.00	2.50	4.98			
Dislivelli			0.00	1.23	-0.41	-1.62	-0.00			

Sezione: 55
 Progressiva: 340.000
 Q. Progetto: 417.726

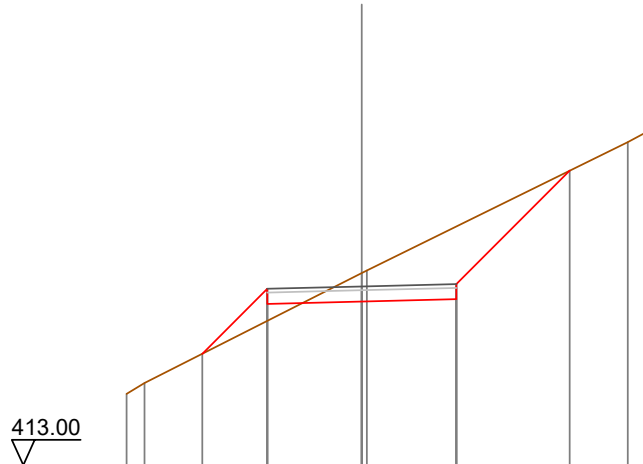

Quote Terreno		-414.88	-415.17			418.08	-418.15			-421.54	-421.79
Quote Progetto				415.94	417.26	417.33	417.39	420.79			
Parziali				1.72	2.50	2.50	3.00				
Progressiva				-4.22	-2.50	0.00	2.50	5.50			
Dislivelli				-0.00	0.85	-0.75	-1.92	0.00			

Sezione: 56
 Progressiva: 348.908
 Q. Progetto: 417.322

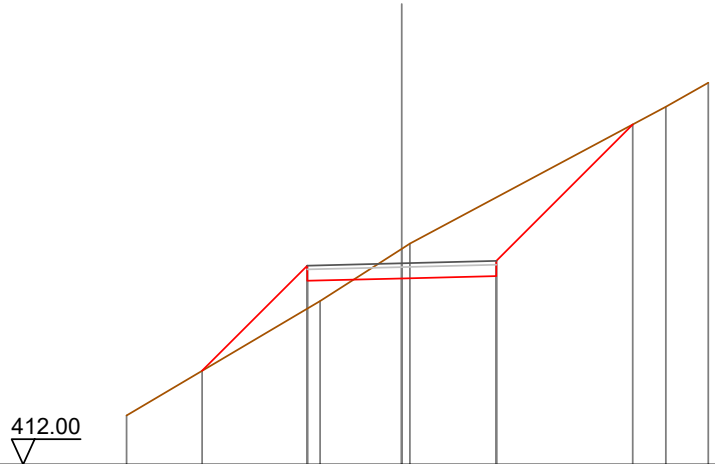

Quote Terreno		413.30		416.32	417.70	417.84		421.46	422.10
Quote Progetto			414.48	416.86	416.92	416.98		420.99	
Parziali			2.78	2.50	2.50	3.61			
Progressiva			-5.28	-2.50	0.00	2.50		6.11	
Dislivelli			-0.00	1.14	-0.78	-2.08		-0.00	

Sezione: 57
 Progressiva: 360.000
 Q. Progetto: 416.835

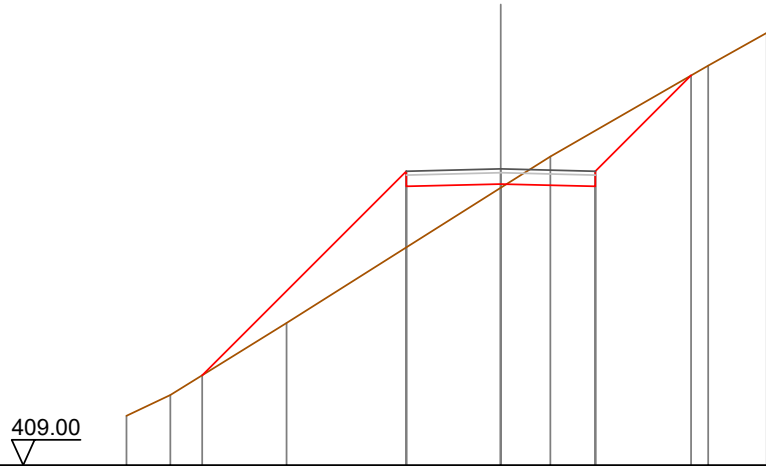

Quote Terreno		410.31	410.85	412.76		416.34	417.16	419.57	420.43
Quote Progetto			411.37		416.37	416.44	416.37	419.31	
Parziali			5.40		2.50	2.50	2.53		
Progressiva			-7.90		-2.50	0.00	2.50	5.03	
Dislivelli			0.00		2.02	0.10	-1.48	0.00	

Sezione: 58
 Progressiva: 373.894
 Q. Progetto: 416.292

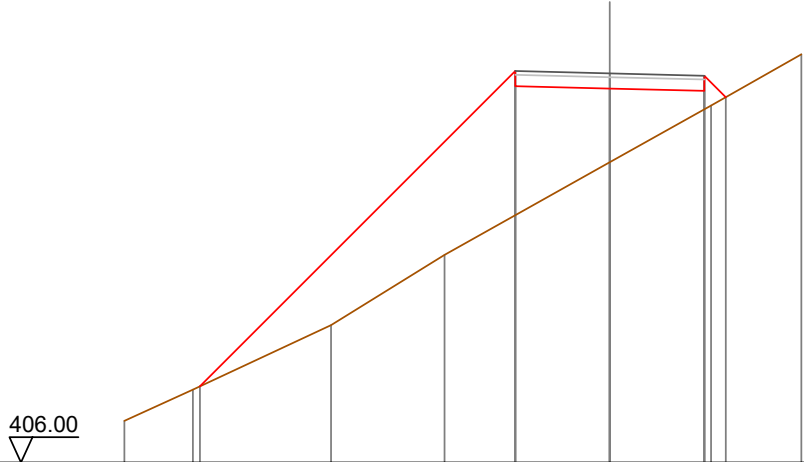

Quote Terreno	-407.10	-407.93	-409.63	-411.49	-415.95	-413.94	-415.44	-416.80
Quote Progetto		408.02			415.95	415.89	415.83	415.66
Parziali			8.34		2.50	2.50	0.57	
Progressiva		-10.84			-2.50	0.00	2.50	3.07
Dislivelli		-0.00			3.82	1.95	0.49	0.00

Sezione: 59
 Progressiva: 378.715
 Q. Progetto: 416.182

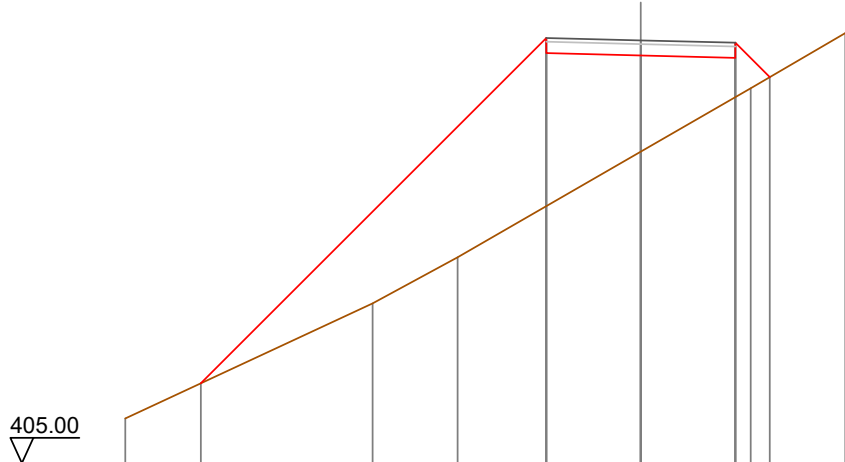

Quote Terreno	-406.18	-409.23	-410.44	-415.84	-413.24	-414.92	-416.38
Quote Progetto		407.11		415.84	415.78	415.72	415.21
Parziali			9.13	2.50	2.50	0.91	
Progressiva		-11.63		-2.50	0.00	2.50	3.41
Dislivelli		0.00		4.45	2.54	1.04	-0.00

Sezione: 60
 Progressiva: 380.000
 Q. Progetto: 416.161

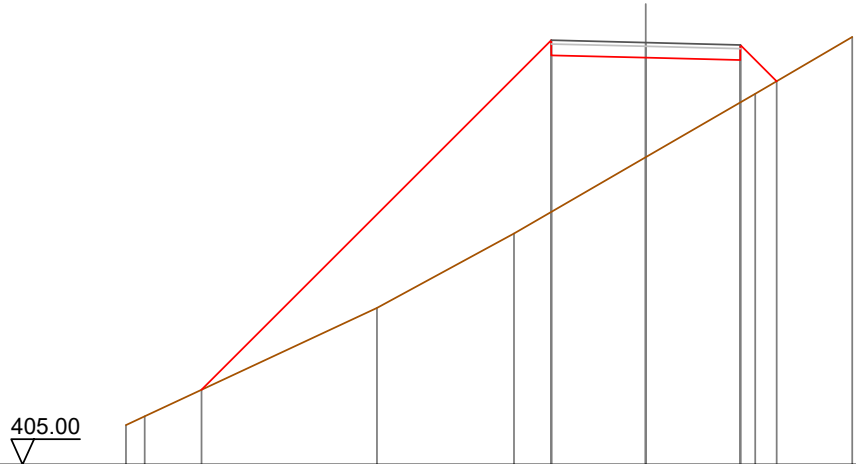

Quote Terreno		406.04	406.27		409.14	411.11	413.13	414.81	416.31
Quote Progetto			406.98			415.82	415.76	415.70	415.14
Parziali				9.25		2.50	2.50	0.96	
Progressiva			-11.75			-2.50	0.00	2.50	3.46
Dislivelli			0.00			4.54	2.63	1.12	-0.00

Sezione: 61
 Progressiva: 383.536
 Q. Progetto: 416.119

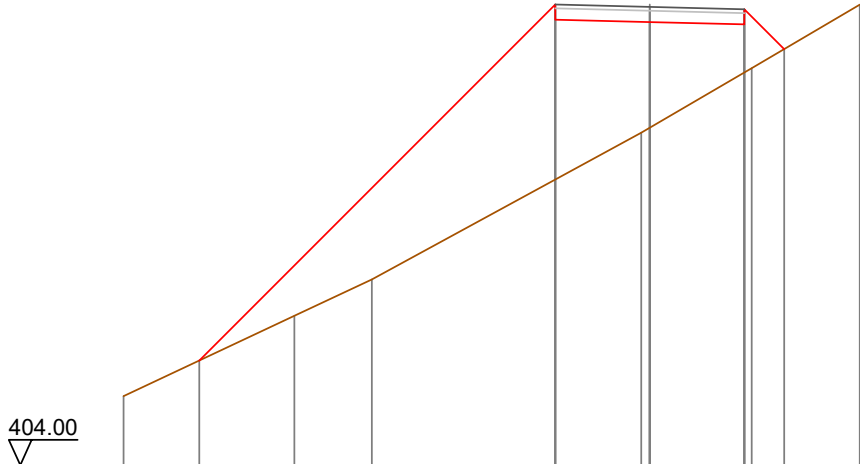

Quote Terreno		405.82		407.95	408.91		412.79	412.93	414.50	416.18
Quote Progetto			406.77			415.78	415.72	415.66	415.00	
Parziali				9.42		2.50	2.50	1.05		
Progressiva			-11.92			-2.50	0.00	2.50	3.55	
Dislivelli			0.00			4.63	2.79	1.27	0.00	

Sezione: 62
 Progressiva: 400.000
 Q. Progetto: 416.254

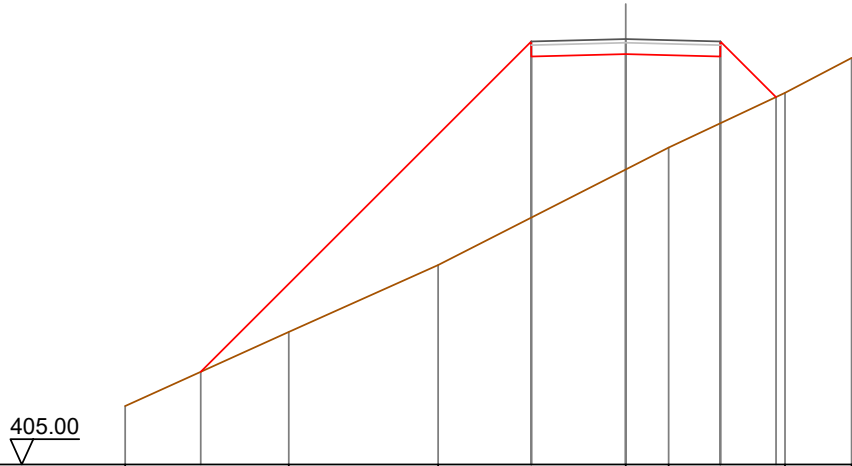

Quote Terreno	-406.55		-408.51	-410.27		412.80	-413.38		-414.83	-415.76
Quote Progetto		407.45			415.79	415.85	415.79	414.72		
Parziali			8.74		2.50	2.50	1.47			
Progressiva		-11.24			-2.50	0.00	2.50	3.97		
Dislivelli		0.00			4.66	3.05	1.77	-0.00		

Sezione: 63
 Progressiva: 405.467
 Q. Progetto: 416.419

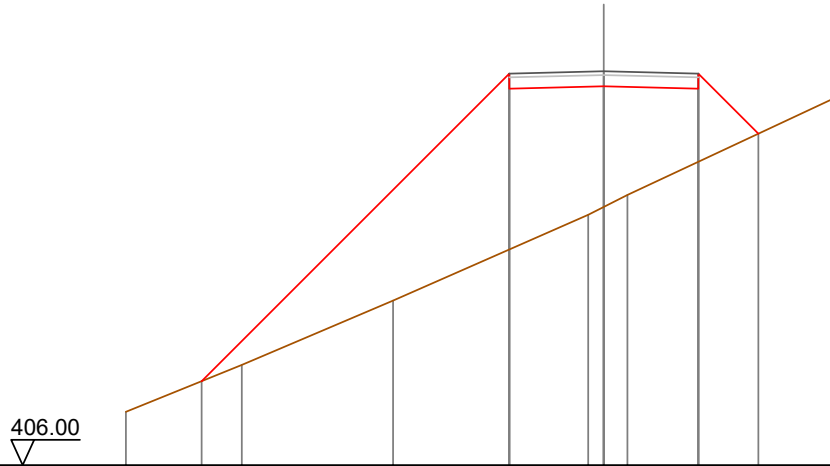

Quote Terreno	-407.41		-408.65	-410.35		412.62	-413.14		-415.70
Quote Progetto		408.22			415.96	416.02	415.96	414.77	
Parziali			8.14		2.50	2.50	1.59		
Progressiva		-10.64			-2.50	0.00	2.50	4.09	
Dislivelli		0.00			4.65	3.19	1.93	0.00	

Sezione: 64
 Progressiva: 417.434
 Q. Progetto: 416.989

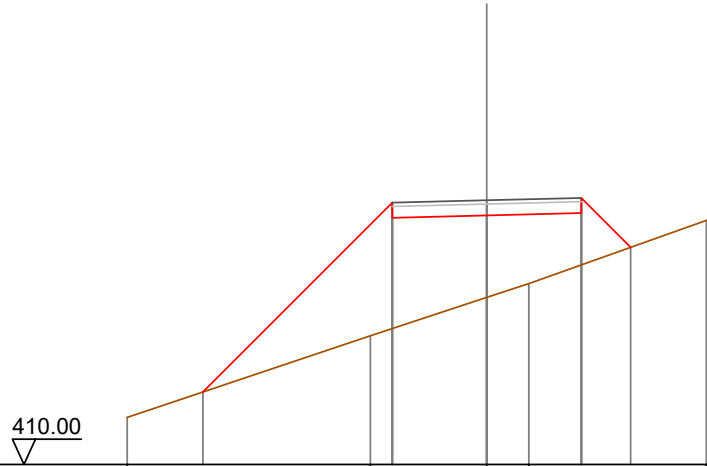

Quote Terreno		-411.25		-413.40		-414.42		-414.79		-416.46
Quote Progetto			411.92		416.53		416.59		416.65	415.75
Parziali				5.01		2.50		2.50		1.31
Progressiva			-7.51		-2.50		0.00		2.50	3.81
Dislivelli			0.00		3.33		2.17		1.37	-0.00

Sezione: 65
 Progressiva: 420.000
 Q. Progetto: 417.149

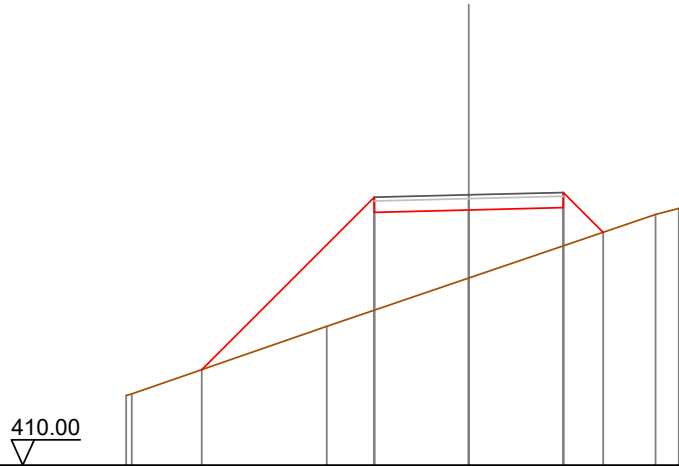

Quote Terreno		411.84		411.88		413.67		414.95		416.63	416.79
Quote Progetto				412.53		416.69		416.75		416.81	416.16
Parziali						4.56		2.50		2.50	1.05
Progressiva				-7.06		-2.50		0.00		2.50	3.55
Dislivelli				-0.00		2.99		1.80		1.01	0.00

Sezione: 66
 Progressiva: 430.000
 Q. Progetto: 417.897

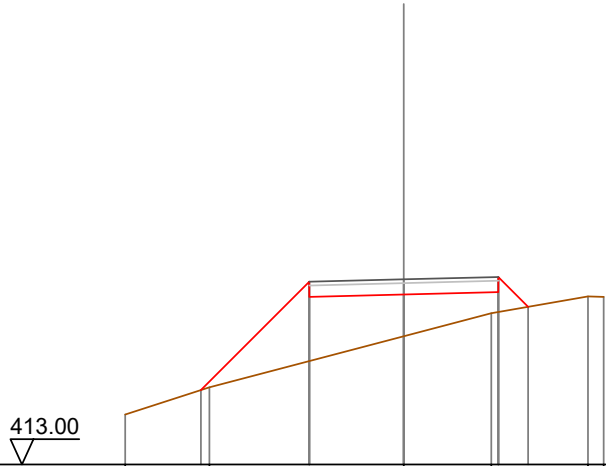

Quote Terreno	-414.32	415.04	417.43	416.39	417.00	417.45	417.43
Quote Progetto		414.97	417.43	417.50	417.56	417.17	
Parziali		2.87	2.50	2.50	0.79		
Progressiva		-5.37	-2.50	0.00	2.50	3.29	
Dislivelli		0.00	2.10	1.10	0.53	0.00	

Sezione: 67
 Progressiva: 435.341
 Q. Progetto: 418.380

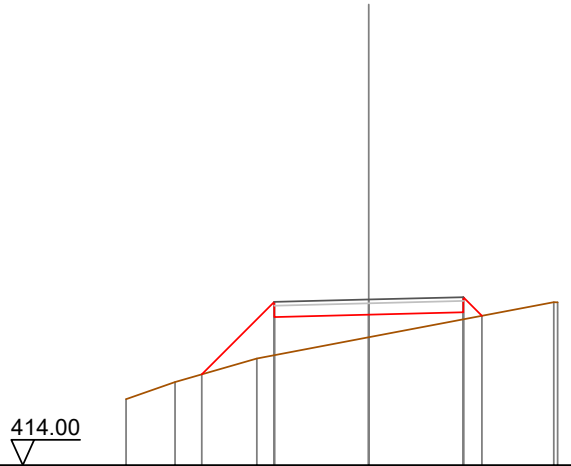

Quote Terreno	415.74	416.20	416.82	417.38	418.04	418.31	418.31
Quote Progetto		416.40	417.92	417.98	418.04	417.95	
Parziali		1.92	2.50	2.50	0.49		
Progressiva		-4.42	-2.50	0.00	2.50	2.99	
Dislivelli		-0.00	1.41	0.60	0.19	0.00	

Sezione: 68
 Progressiva: 440.000
 Q. Progetto: 418.848

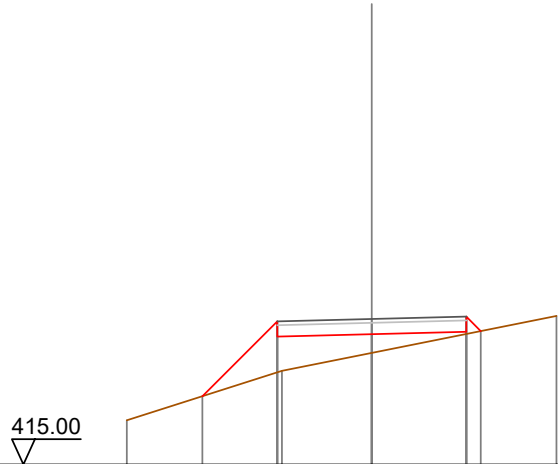

Quote Terreno		-416.17		417.48	417.95		-418.93
Quote Progetto			416.81	418.39	418.45	418.51	418.53
Parziali			1.98	2.50	2.50	0.38	
Progressiva			-4.48	-2.50	0.00	2.50	2.88
Dislivelli			0.00	1.35	0.50	0.06	0.00

Sezione: 69
 Progressiva: 450.000
 Q. Progetto: 420.002

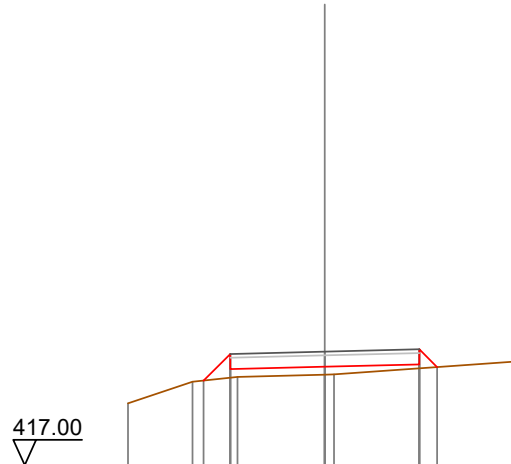

Quote Terreno		-418.64		419.39			-419.73
Quote Progetto			419.24	419.54	419.60	419.66	
Parziali			0.70	2.50	2.50	0.47	
Progressiva			-3.20	-2.50	0.00	2.50	2.97
Dislivelli			-0.00	0.63	0.21	0.11	0.00

Sezione: 70
 Progressiva: 453.248
 Q. Progetto: 420.421

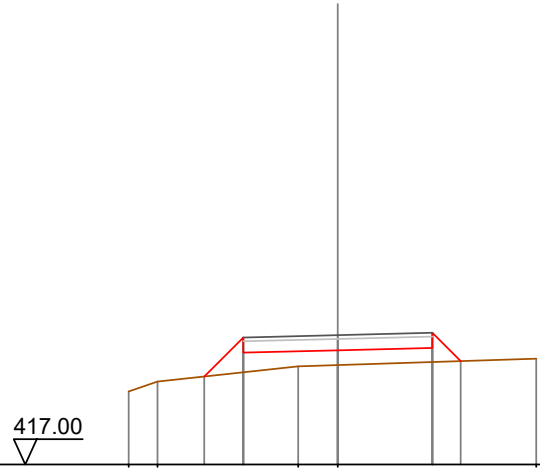

Quote Terreno	-418.93	-419.19		-419.60	-419.63		-419.80
Quote Progetto			419.33	419.96	420.02	420.08	419.73
Parziali			1.03	2.50	2.50	0.75	
Progressiva			-3.53	-2.50	0.00	2.50	3.25
Dislivelli			0.00	0.92	0.39	0.37	0.00

Sezione: 71
 Progressiva: 454.675
 Q. Progetto: 420.612

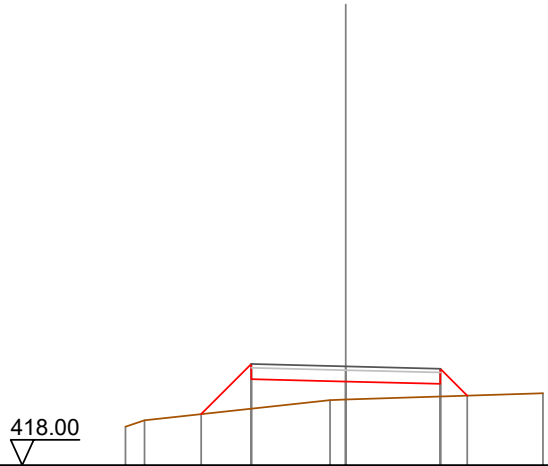

Quote Terreno	-419.01	-419.19		-419.72	-419.73		-419.90
Quote Progetto			419.35	420.27	420.21	420.15	419.84
Parziali			1.32	2.50	2.50	0.71	
Progressiva			-3.82	-2.50	0.00	2.50	3.21
Dislivelli			0.00	1.18	0.48	0.34	0.00

Sezione: 72
 Progressiva: 460.000
 Q. Progetto: 421.361

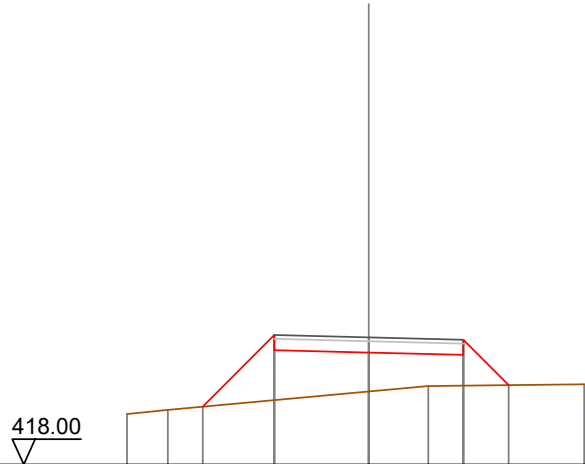

Quote Terreno		419.33	419.45			419.93	420.08		420.12
Quote Progetto			419.53	421.02		420.96	420.90	420.10	
Parziali				1.89	2.50		2.50	1.20	
Progressiva			-4.39	-2.50		0.00	2.50	3.70	
Dislivelli			-0.00	1.72		1.03	0.81	-0.00	

Sezione: 73
 Progressiva: 465.433
 Q. Progetto: 422.167

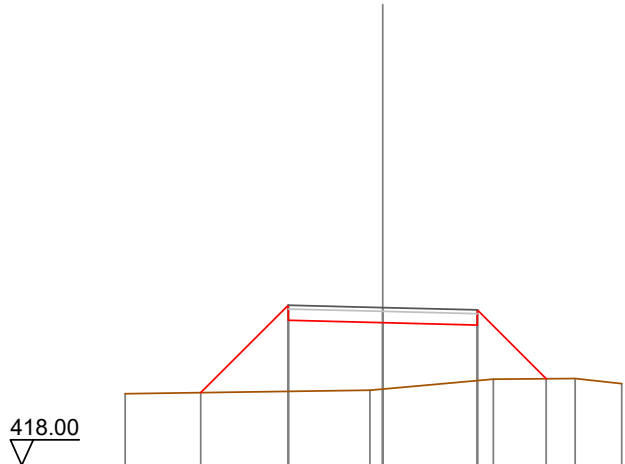

Quote Terreno		419.89				419.98	420.01	420.27	420.29	420.16
Quote Progetto			419.92	421.83		421.77	421.70	420.29		
Parziali				2.31	2.50		2.50	1.82		
Progressiva			-4.81	-2.50		0.00	2.50	4.32		
Dislivelli			-0.00	2.28		1.76	1.47	0.00		

Sezione: 74
 Progressiva: 470.000
 Q. Progetto: 422.846

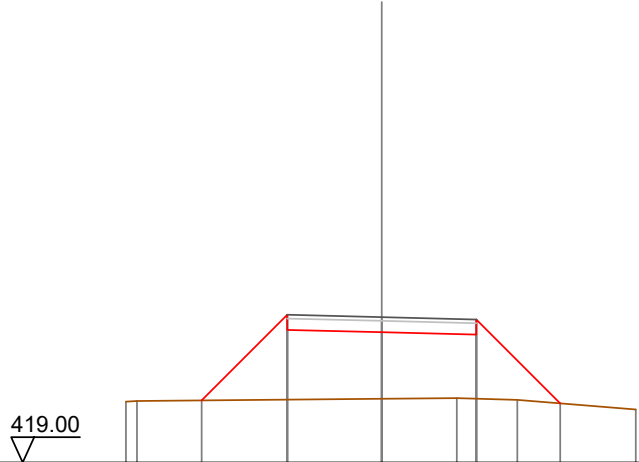

Quote Terreno	420.61	420.63			420.69	420.71	420.66	420.40
Quote Progetto			420.64	422.51	422.45	422.38	420.56	
Parziali			2.26	2.50	2.50	2.22		
Progressiva			-4.76	-2.50	0.00	2.50	4.72	
Dislivelli			0.00	2.24	1.76	1.69	0.00	

Sezione: 75
 Progressiva: 476.191
 Q. Progetto: 423.750

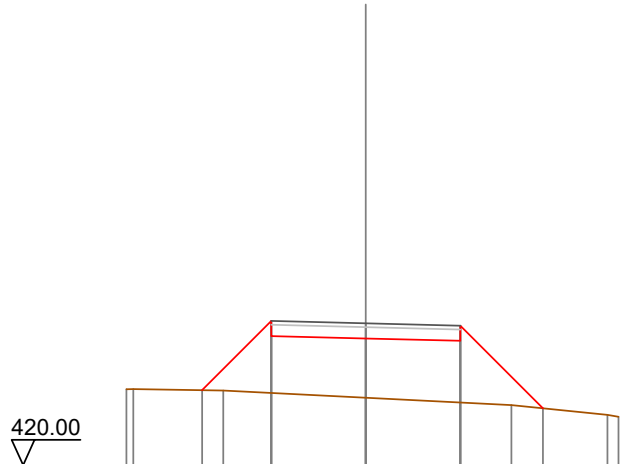

Quote Terreno	422.01	422.01	421.97		421.78		421.59	421.33	421.28
Quote Progetto			421.98	423.41	423.35	423.29	421.50		
Parziali			1.83	2.50	2.50	2.19			
Progressiva			-4.33	-2.50	0.00	2.50	4.69		
Dislivelli			-0.00	1.90	1.57	1.63	-0.00		

Sezione: 76
 Progressiva: 480.000
 Q. Progetto: 424.271

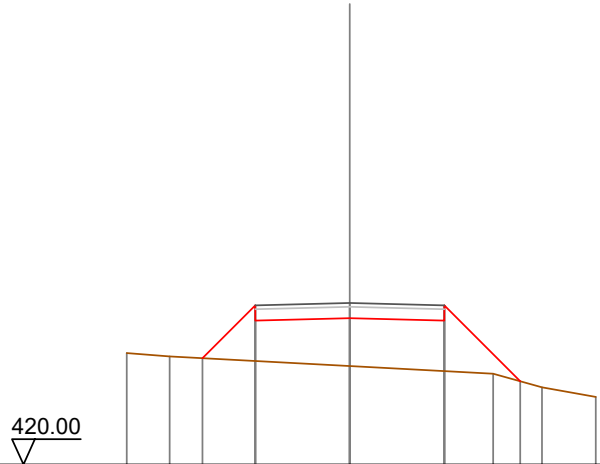

Quote Terreno		-422.95	-422.86		422.60		-422.40	-422.04	-421.79
Quote Progetto			422.81	423.81	423.87	423.81	422.20		
Parziali			1.40	2.50	2.50	2.01			
Progressiva			-3.90	-2.50	0.00	2.50	4.51		
Dislivelli			0.00	1.47	1.27	1.34	0.00		

Sezione: 77
 Progressiva: 500.000
 Q. Progetto: 426.519

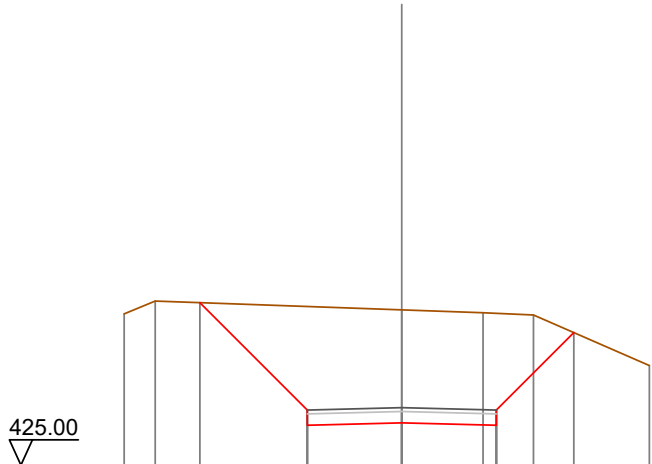

Quote Terreno		425.00	425.34		425.11	425.03	425.97		427.63
Quote Progetto			426.30	426.06	426.12	426.06	428.51		
Parziali			2.84	2.50	2.50	2.05			
Progressiva			-5.34	-2.50	0.00	2.50	4.55		
Dislivelli			-0.00	-2.74	-2.99	-2.96	0.00		

Sezione: 78
 Progressiva: 520.000
 Q. Progetto: 427.956

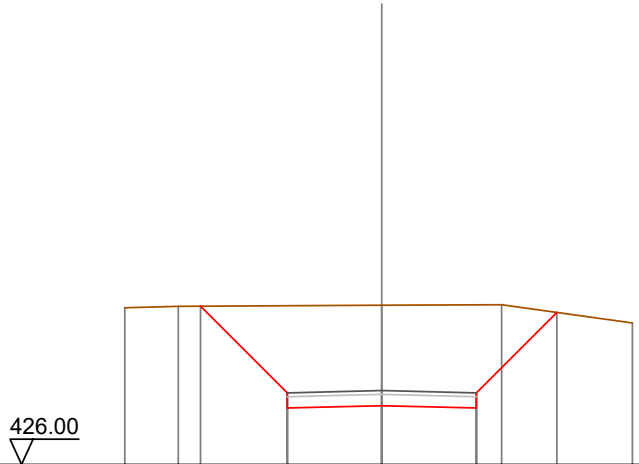

Quote Terreno		-430.14	-430.18		430.21	-430.23		-429.74
Quote Progetto			430.19	427.49	427.56	427.49	430.02	
Parziali				2.29	2.50	2.50	2.13	
Progressiva			-4.79	-2.50	0.00	2.50	4.63	
Dislivelli			0.00	-2.31	-2.66	-2.73	0.00	

Sezione: 79
 Progressiva: 540.000
 Q. Progetto: 428.590

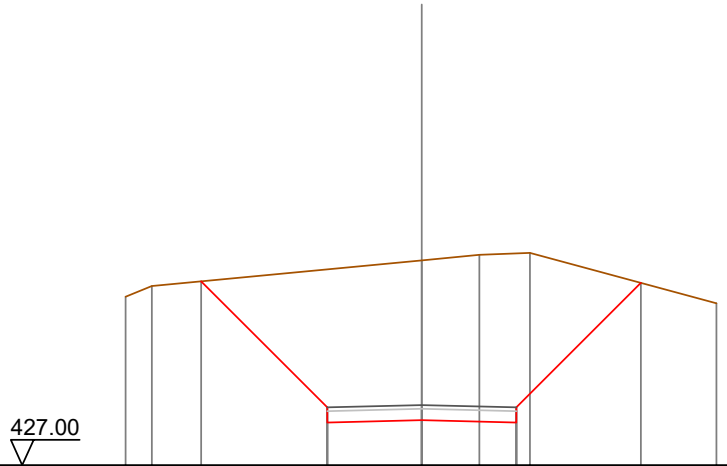

Quote Terreno		-431.45	-431.74		432.42	-432.56	-432.61		-431.28
Quote Progetto			431.86	428.13	428.19	428.13	431.82		
Parziali				3.33	2.50	2.50	3.29		
Progressiva			-5.83	-2.50	0.00	2.50	5.79		
Dislivelli			-0.00	-3.65	-4.23	-4.47	0.00		

Sezione: 80
 Progressiva: 560.000
 Q. Progetto: 428.542

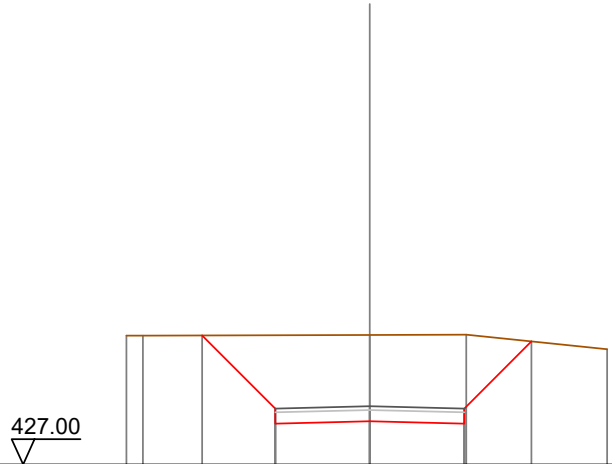

Quote Terreno		-430.41	-430.41	-430.43	-430.43	-430.05	
Quote Progetto			430.41	428.08	428.14	428.08	430.26
Parziali			1.93	2.50	2.50	1.78	
Progressiva			-4.43	-2.50	0.00	2.50	4.28
Dislivelli			0.00	-1.94	-2.28	-2.35	0.00

Sezione: 81
 Progressiva: 568.341
 Q. Progetto: 428.362

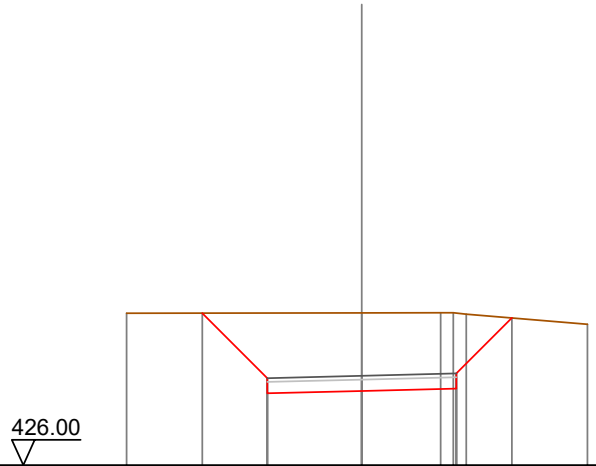

Quote Terreno		-430.02	-430.03	-430.03	-430.03	-429.73	
Quote Progetto			430.02	427.90	427.96	428.02	429.89
Parziali			1.72	2.50	2.50	1.47	
Progressiva			-4.22	-2.50	0.00	2.50	3.97
Dislivelli			-0.00	-1.72	-2.06	-2.00	0.00

Sezione: 82
 Progressiva: 570.000
 Q. Progetto: 428.310

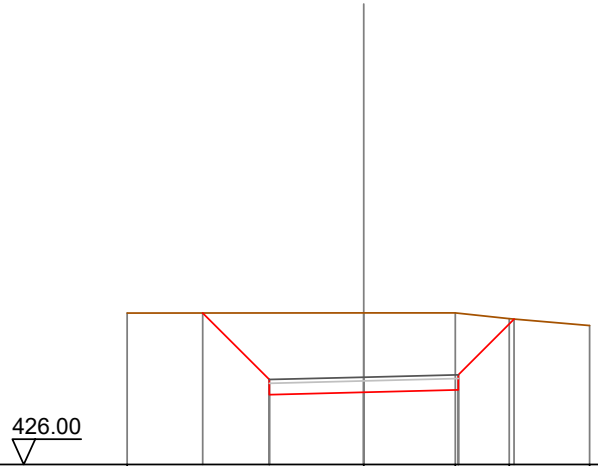

Quote Terreno		430.00			430.01		430.01		429.86		429.68
Quote Progetto			430.01		427.85		427.91		427.97		429.85
Parziali			1.76		2.50		2.50		1.47		
Progressiva			-4.26		-2.50		0.00		2.50		3.97
Dislivelli			0.00		-1.76		-2.10		-2.03		-0.00

Sezione: 83
 Progressiva: 572.872
 Q. Progetto: 428.206

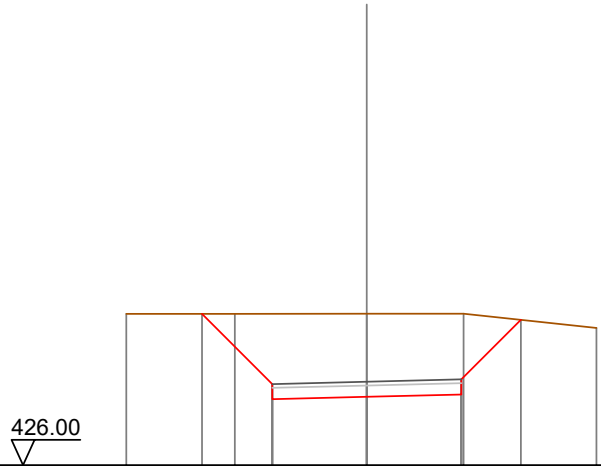

Quote Terreno		430.00			430.00		430.00		430.01		429.63
Quote Progetto			430.00		427.74		427.81		427.87		429.84
Parziali			1.86		2.50		2.50		1.57		
Progressiva			-4.36		-2.50		0.00		2.50		4.07
Dislivelli			-0.00		-1.86		-2.20		-2.14		0.00

Sezione: 84
 Progressiva: 577.403
 Q. Progetto: 428.009

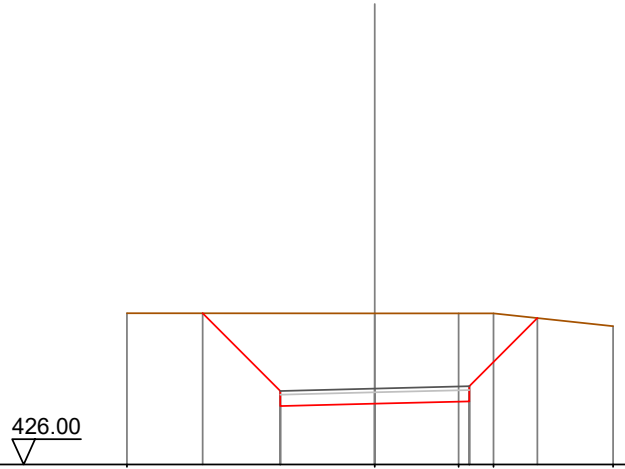

Quote Terreno		430.00			430.00		430.00		430.00		429.66
Quote Progetto			430.00		427.55		427.61		427.67		429.87
Parziali			2.05		2.50		2.50		1.80		
Progressiva			-4.55		-2.50		0.00		2.50		4.30
Dislivelli			0.00		-2.05		-2.39		-2.32		0.00

Sezione: 85
 Progressiva: 580.000
 Q. Progetto: 427.877

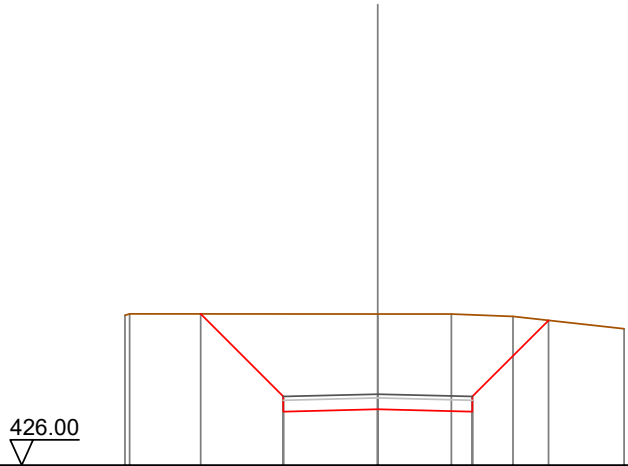

Quote Terreno		429.96			430.00		430.00		430.00		429.93		429.61
Quote Progetto			430.00		427.41		427.48		427.41		429.83		
Parziali			2.18		2.50		2.50		2.01				
Progressiva			-4.68		-2.50		0.00		2.50		4.51		
Dislivelli			0.00		-2.18		-2.52		-2.56		-0.00		

Sezione: 86
 Progressiva: 600.000
 Q. Progetto: 426.408

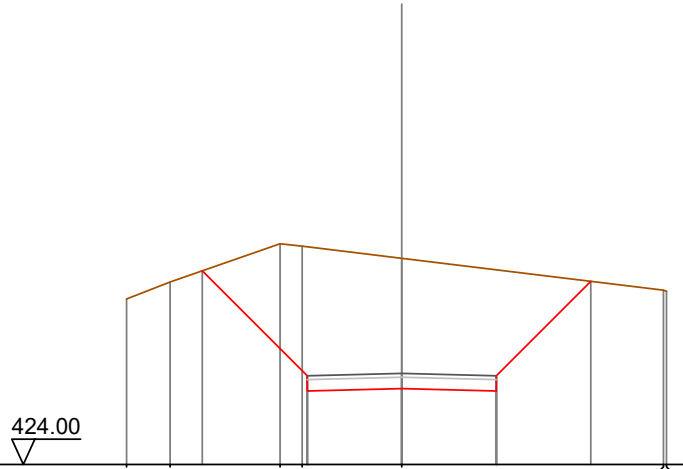

Quote Terreno		-428.38	-428.83	-429.84	-429.77	-429.45		-428.61	-428.58
Quote Progetto			429.12		425.95	426.01		425.95	428.85
Parziali				2.78	2.50	2.50		2.50	
Progressiva			-5.28		-2.50	0.00		2.50	5.00
Dislivelli			0.00		-3.41	-3.45		-3.20	0.00

Sezione: 87
 Progressiva: 620.000
 Q. Progetto: 424.128

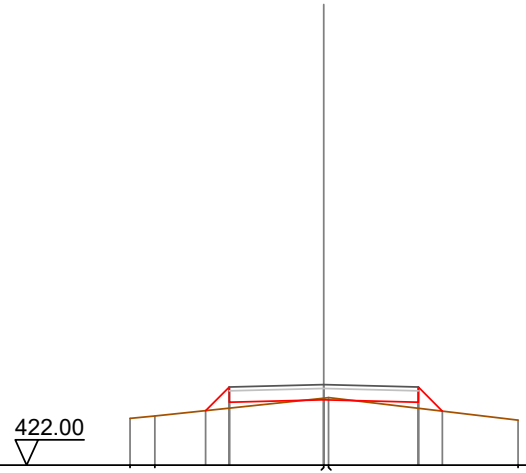

Quote Terreno		-423.24	-423.30		-423.77	-423.79		-423.19	
Quote Progetto				423.44	423.67	423.73		423.67	423.43
Parziali				0.62	2.50	2.50		0.64	
Progressiva			-3.12		-2.50	0.00		2.50	3.14
Dislivelli			0.00		0.56	-0.04		0.16	0.00

Sezione: 88
 Progressiva: 620.974
 Q. Progetto: 423.996

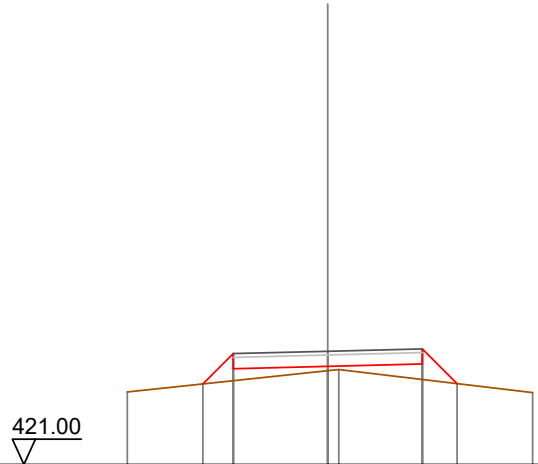

Quote Terreno		422.92			423.48	423.51			422.90
Quote Progetto			423.13	423.53	423.60	423.51	423.66	423.14	
Parziali			0.80	2.50	2.50	0.92			
Progressiva			-3.30	-2.50	0.00	2.50	3.42		
Dislivelli			-0.00	0.72	0.12	0.41	0.00		

Sezione: 89
 Progressiva: 624.770
 Q. Progetto: 423.463

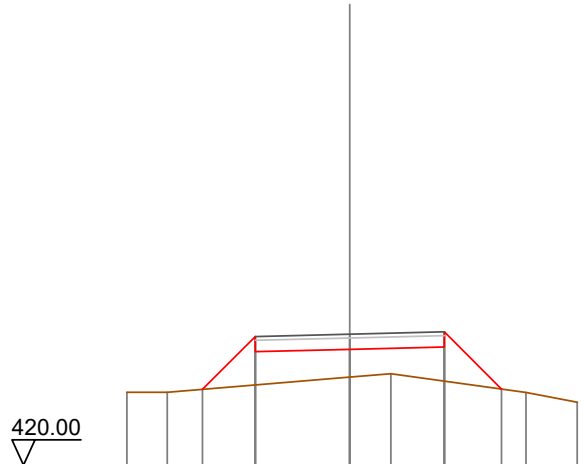

Quote Terreno		421.93	421.93		422.33	422.42		421.92	421.67
Quote Progetto			422.01	423.00	423.06	422.33	423.13	422.01	
Parziali			1.40	2.50	2.50	1.51			
Progressiva			-3.90	-2.50	0.00	2.50	4.01		
Dislivelli			-0.00	1.28	0.74	0.90	0.00		

Sezione: 90
 Progressiva: 628.567
 Q. Progetto: 422.900

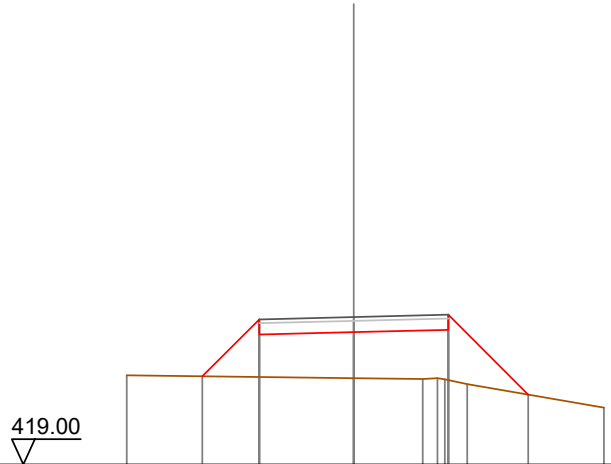

Quote Terreno		421.36			421.28		421.26	421.25	421.13		420.51
Quote Progetto			421.33		422.50		422.56		420.85		
Parziali			1.51	2.50		2.50		2.11			
Progressiva			-4.01	-2.50	0.00		2.50		4.61		
Dislivelli			0.00	1.52	1.22		1.33		-0.00		

Sezione: 91
 Progressiva: 640.000
 Q. Progetto: 421.025

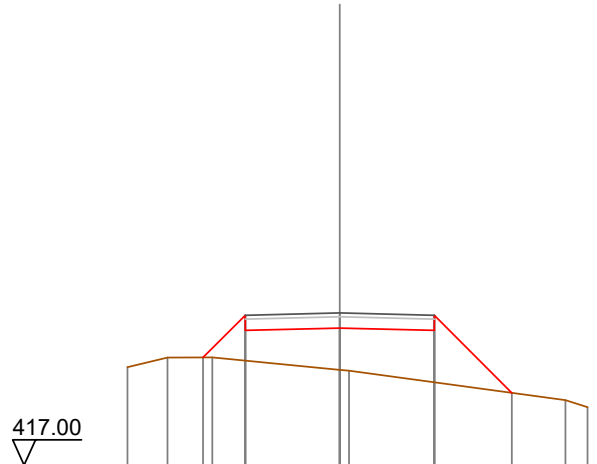

Quote Terreno		419.59		419.84	419.85		419.52	419.50		418.72	418.53
Quote Progetto				419.85	420.56		420.63	420.56		418.91	
Parziali				1.11	2.50		2.50		2.05		
Progressiva			-3.61	-2.50		0.00	2.50		4.55		
Dislivelli			0.00	1.20		1.11	1.37		0.00		

Sezione: 92
 Progressiva: 660.000
 Q. Progetto: 417.116

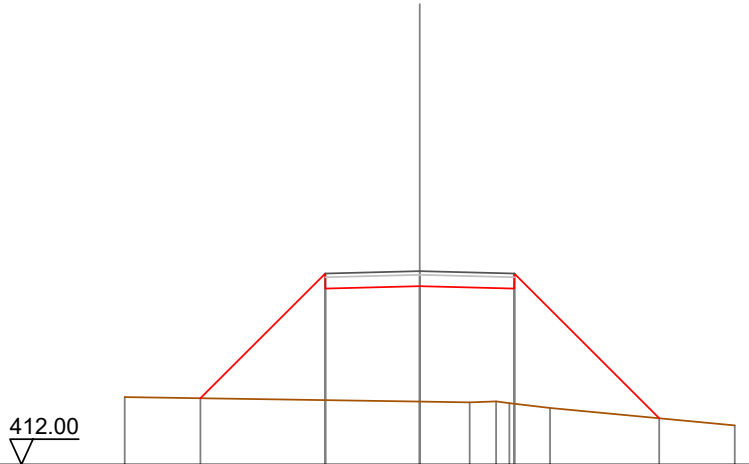

Quote Terreno		-413.78				413.66	-413.64	-413.67	-413.62	-413.49		-413.03
Quote Progetto			413.75		416.65	416.72	413.66	416.65	416.65		413.22	
Parziali			3.30		2.50	2.50		3.83				
Progressiva			-5.80		-2.50	0.00	2.50		6.33			
Dislivelli			0.00		3.35	3.05	3.05	0.00				

Sezione: 93
 Progressiva: 680.000
 Q. Progetto: 413.339

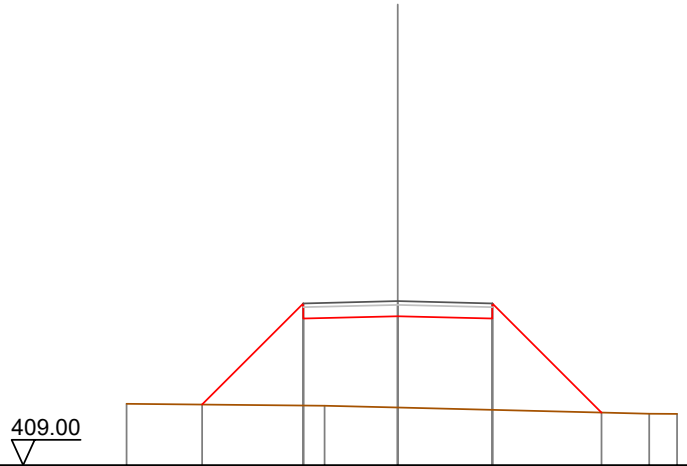

Quote Terreno		-410.62				410.52					-410.36	-410.35
Quote Progetto			410.60		412.88	412.94	412.88	410.39				
Parziali			2.67		2.50	2.50		2.89				
Progressiva			-5.17		-2.50	0.00	2.50	5.39				
Dislivelli			0.00		2.70	2.42	2.42	0.00				

Sezione: 94
 Progressiva: 682.087
 Q. Progetto: 412.993

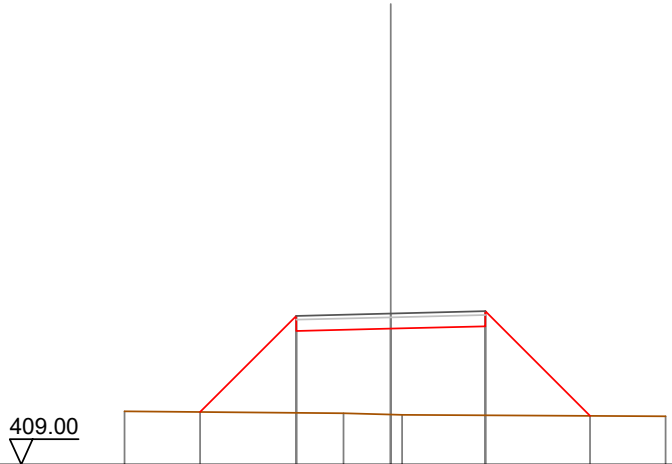

Quote Terreno		410.41		410.35	410.32	410.32		410.28
Quote Progetto			410.39	412.53	412.59	412.66		410.29
Parziali			2.54	2.50	2.50	2.77		
Progressiva			-5.04	-2.50	0.00	2.50		5.27
Dislivelli			0.00	2.56	2.27	2.35		0.00

Sezione: 95
 Progressiva: 684.171
 Q. Progetto: 412.657

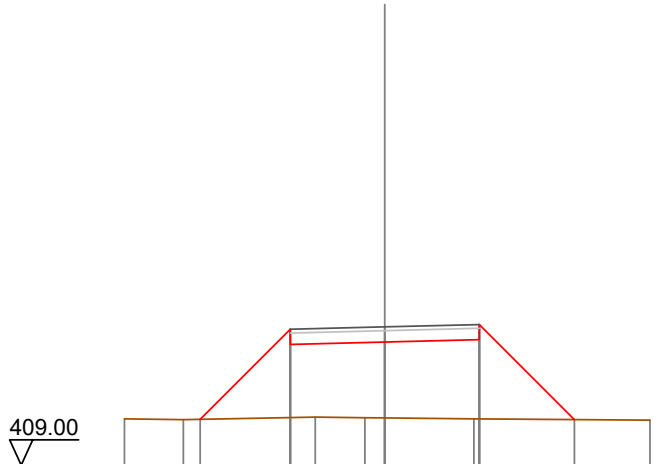

Quote Terreno		410.22	410.20	410.27	410.25	410.25	410.22	410.19
Quote Progetto			410.21	412.19	412.26	412.32	410.20	
Parziali			2.38	2.50	2.50	2.52		
Progressiva			-4.88	-2.50	0.00	2.50		5.02
Dislivelli			0.00	2.34	2.01	2.10		-0.00

Sezione: 96
 Progressiva: 686.256
 Q. Progetto: 412.329

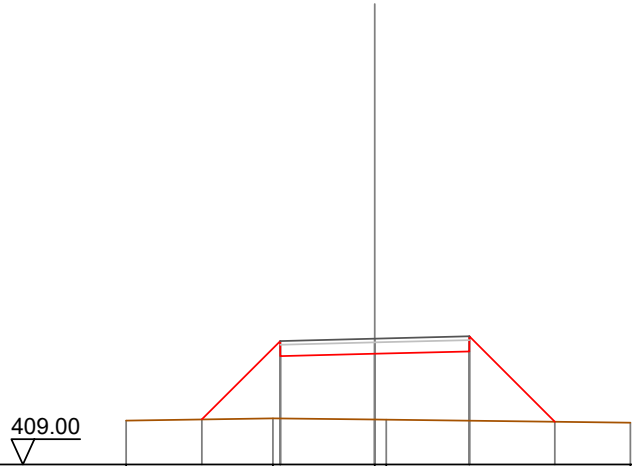

Quote Terreno		-410.16		410.22	410.19	410.19		-410.11
Quote Progetto			410.19	411.87	411.93	411.99	410.13	
Parziali			2.07	2.50	2.50	2.26		
Progressiva			-4.57	-2.50	0.00	2.50	4.76	
Dislivelli			0.00	2.05	1.74	1.83	-0.00	

Sezione: 97
 Progressiva: 700.000
 Q. Progetto: 410.395

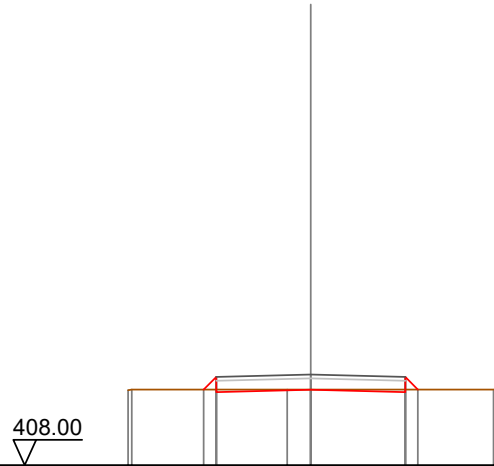

Quote Terreno		409.98	410.00		410.00	410.00		410.00
Quote Progetto			410.00	409.93	409.99	409.93	410.00	
Parziali			0.33	2.50	2.50	0.33		
Progressiva			-2.83	-2.50	0.00	2.50	2.83	
Dislivelli			-0.00	0.33	-0.01	-0.07	-0.00	

Sezione: 98
 Progressiva: 720.000
 Q. Progetto: 408.027

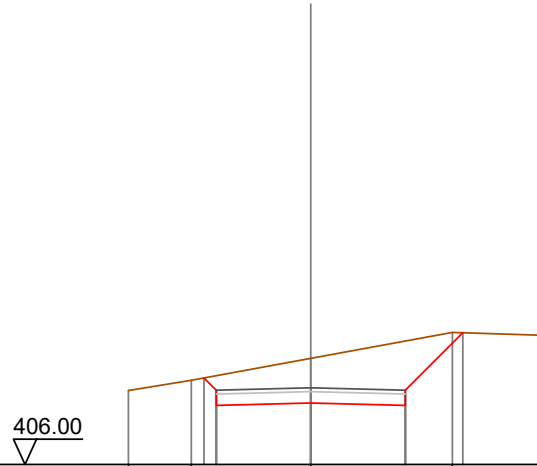

Quote Terreno	-407.96	-408.23	-408.81	-409.49	-409.42	
Quote Progetto		408.29	407.63	407.56	409.48	
Parziali		0.32	2.50	2.50	1.52	
Progressiva		-2.82	-2.50	0.00	2.50	4.02
Dislivelli		0.00	-0.38	-1.18	-1.70	0.00

Sezione: 99
 Progressiva: 734.181
 Q. Progetto: 406.364

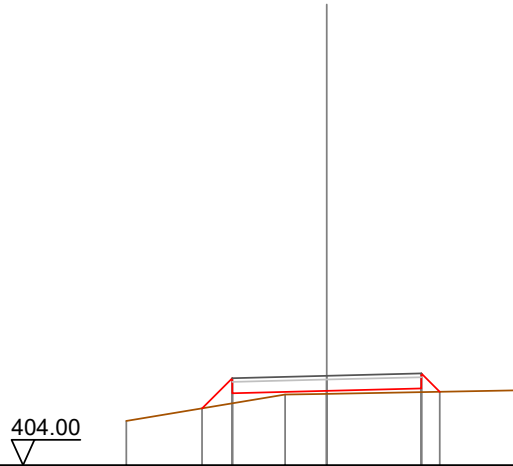

Quote Terreno	-405.17	-405.87	-405.89	-405.98		
Quote Progetto		405.50	405.90	405.96	406.03	405.94
Parziali		0.80	2.50	2.50	0.49	
Progressiva		-3.30	-2.50	0.00	2.50	2.99
Dislivelli		-0.00	0.67	0.08	0.09	0.00

Sezione: 100
 Progressiva: 736.388
 Q. Progetto: 406.105

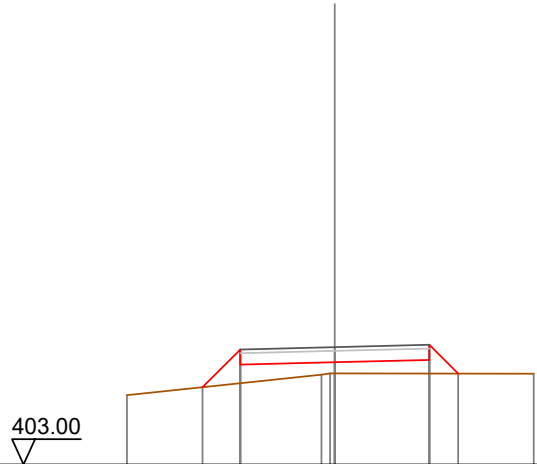

Quote Terreno		404.83		405.38	405.41			405.77	405.41		405.40
Quote Progetto			405.04	405.64	405.70		405.77	405.41			
Parziali			1.00	2.50	2.50		0.76				
Progressiva			-3.50	-2.50	0.00		2.50	3.26			
Dislivelli			0.00	0.89	0.29		0.36	0.00			

Sezione: 101
 Progressiva: 738.594
 Q. Progetto: 405.846

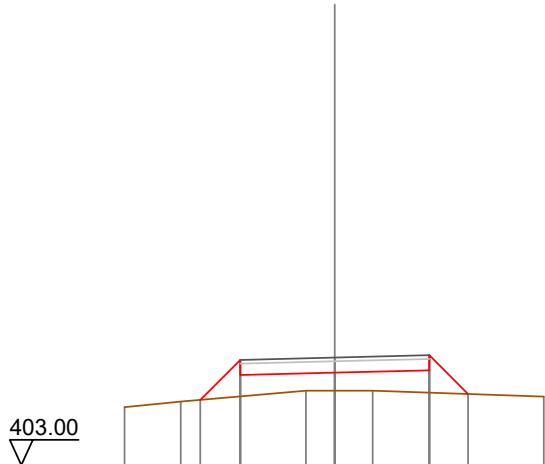

Quote Terreno		404.53	404.68	404.97	404.97	404.97		405.51		404.81
Quote Progetto			404.73	405.38	405.45	405.51	404.88			
Parziali			1.06	2.50	2.50	1.03				
Progressiva			-3.56	-2.50	0.00	2.50	3.53			
Dislivelli			-0.00	0.97	0.48	0.59	0.00			

Sezione: 102
 Progressiva: 740.000
 Q. Progetto: 405.681

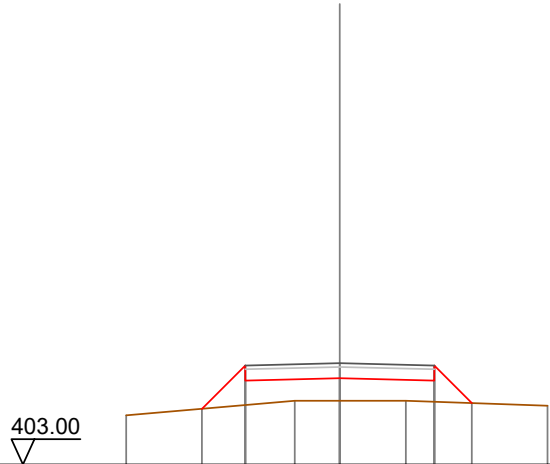

Quote Terreno	-404.30		-404.68	-404.68	-404.69		-404.56
Quote Progetto		404.47	405.22	405.28	405.22	404.63	
Parziali		1.15	2.50	2.50	0.99		
Progressiva		-3.65	-2.50	0.00	2.50	3.49	
Dislivelli		-0.00	1.05	0.60	0.56	-0.00	

Sezione: 103
 Progressiva: 760.000
 Q. Progetto: 403.335

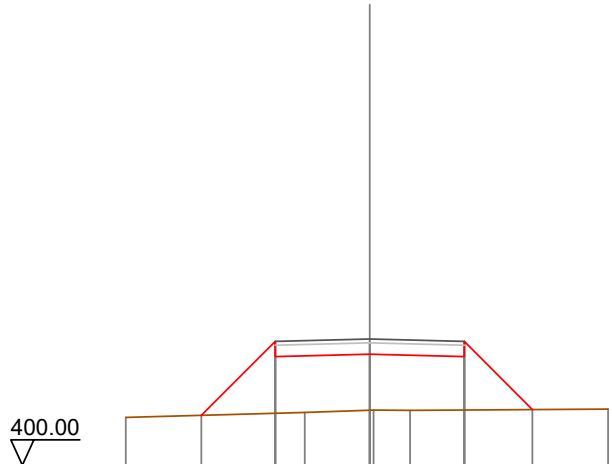

Quote Terreno	-401.26		-401.39	-401.45	-401.46	-401.45		-401.48
Quote Progetto		401.32	402.87	402.93	401.46	402.87	401.47	
Parziali		1.95	2.50	2.50	1.80			
Progressiva		-4.45	-2.50	0.00	2.50	4.30		
Dislivelli		-0.00	1.90	1.48	1.41	0.00		

Sezione: 104
 Progressiva: 773.640
 Q. Progetto: 401.922

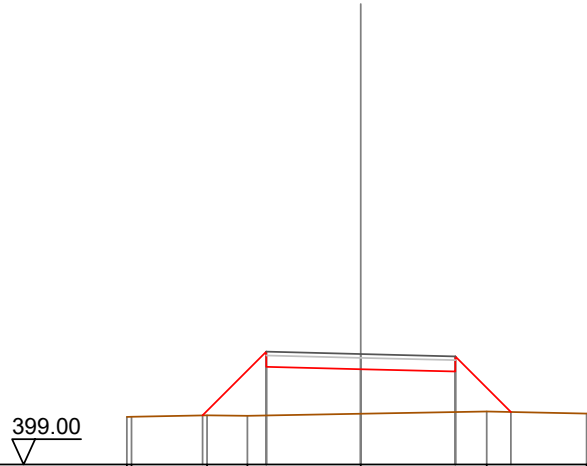

Quote Terreno		400.26	400.26	400.30	400.29	400.34	400.40	400.35
Quote Progetto			400.30	401.58	401.52	401.46	400.39	
Parziali				1.68	2.50	2.50	1.47	
Progressiva			-4.18	-2.50	0.00	2.50	3.97	
Dislivelli			0.00	1.69	1.18	1.07	-0.00	

Sezione: 105
 Progressiva: 777.524
 Q. Progetto: 401.589

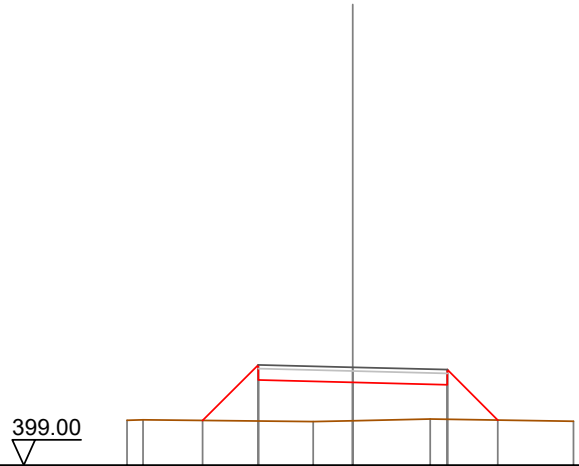

Quote Terreno		400.19	400.20		400.15	400.17	400.22	400.16
Quote Progetto				400.18	401.25	401.19	401.13	400.19
Parziali				1.47	2.50	2.50	1.34	
Progressiva				-3.97	-2.50	0.00	2.50	3.84
Dislivelli				-0.00	1.48	1.01	0.92	0.00

Sezione: 106
 Progressiva: 780.000
 Q. Progetto: 401.392

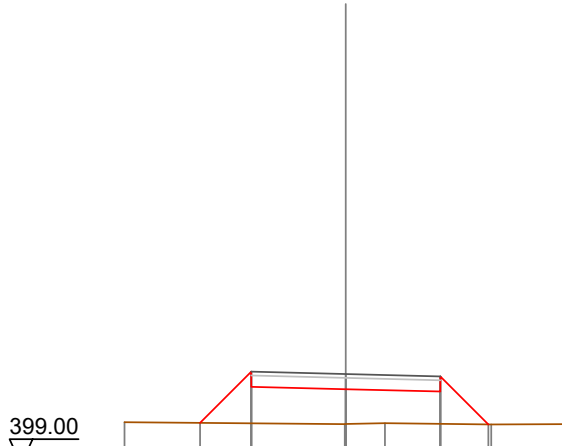

Quote Terreno		400.12			400.07	400.07			400.06	400.07
Quote Progetto			400.10	401.05	400.99			400.93	400.06	
Parziali			1.35	2.50		2.50		1.27		
Progressiva			-3.85	-2.50	0.00		2.50	3.77		
Dislivelli			0.00	1.36	0.92		0.85	-0.00		

Sezione: 107
 Progressiva: 781.408
 Q. Progetto: 401.286

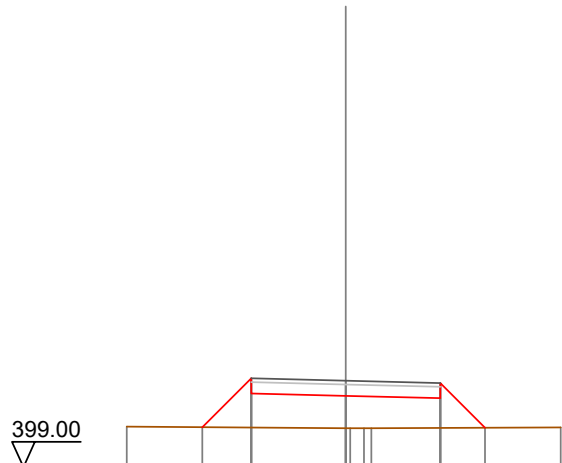

Quote Terreno		400.07			400.03	400.03			400.05
Quote Progetto			400.06	400.95	400.89		400.82	400.04	
Parziali			1.29	2.50		2.50	1.18		
Progressiva			-3.79	-2.50	0.00		2.50	3.68	
Dislivelli			-0.00	1.30	0.86		0.79	-0.00	

Sezione: 108
 Progressiva: 800.000
 Q. Progetto: 400.257

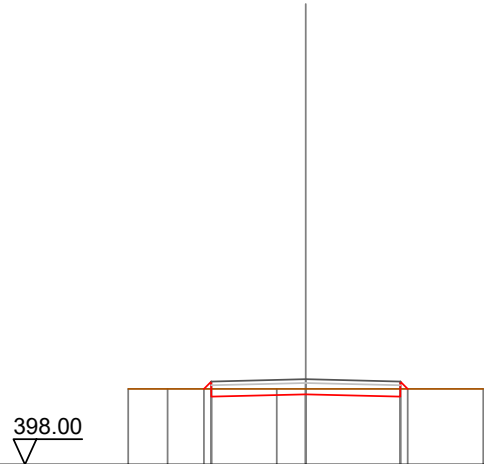

Quote Terreno		400.00	400.00	400.00	400.00	400.00
Quote Progetto			400.00	399.79	399.86	400.00
Parziali				2.50	2.50	
Progressiva			-2.69	-2.50	0.00	2.50
Dislivelli			-0.00	0.19	-0.14	-0.21

Sezione: 109
 Progressiva: 820.000
 Q. Progetto: 399.923

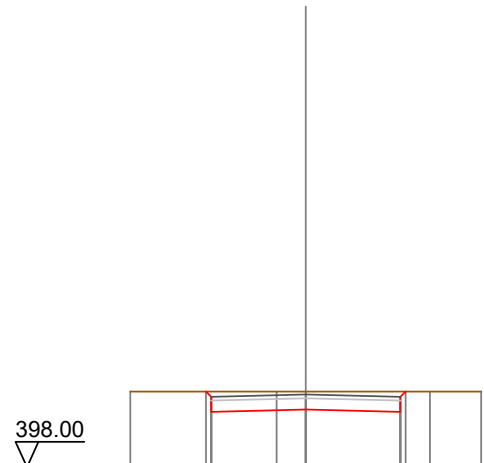

Quote Terreno		400.00	400.00	400.00	400.00	400.00
Quote Progetto			400.00	399.46	399.52	400.00
Parziali				2.50	2.50	
Progressiva			-2.64	-2.50	0.00	2.50
Dislivelli			0.00	-0.14	-0.48	-0.54

Sezione: 110
 Progressiva: 840.000
 Q. Progetto: 399.941

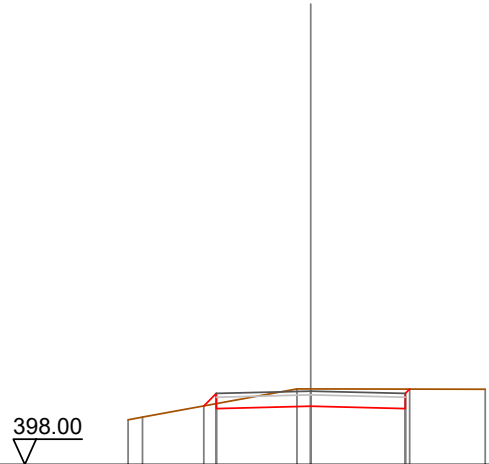

Quote Terreno	-399.18	-399.25	-400.00	-400.00	-399.99
Quote Progetto			399.55	399.48	399.54
Parziali			0.33	2.50	2.50
Progressiva			-2.83	-2.50	0.00
Dislivelli			0.00	0.27	-0.46
					2.50
					2.62
					0.00

Sezione: 111
 Progressiva: 857.560
 Q. Progetto: 399.958

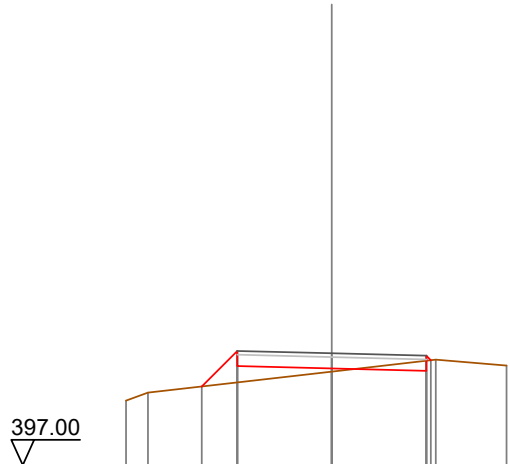

Quote Terreno	-398.71	-398.92	-399.08	-399.62	-399.47	-399.50	-399.79	-399.63
Quote Progetto			399.08	399.62	399.56	399.47	399.50	399.77
Parziali			0.94	2.50	2.50			
Progressiva			-3.44	-2.50	0.00	2.50	2.62	
Dislivelli			-0.00	0.83	0.08	-0.26	0.00	

Sezione: 112
 Progressiva: 860.000
 Q. Progetto: 399.960

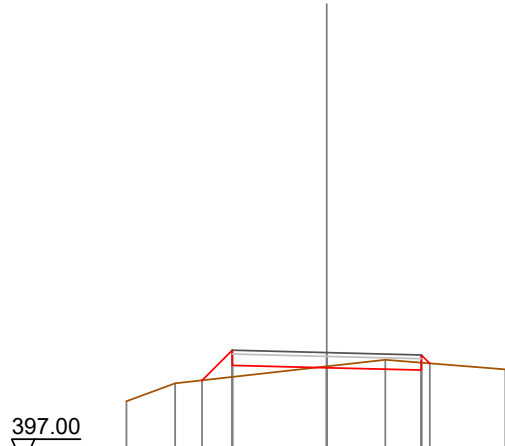

Quote Terreno	-398.67	-399.15		399.56	-399.77	-399.51
Quote Progetto			399.23	399.62	399.50	399.67
Parziali			0.80	2.50	2.50	
Progressiva		-3.30	-2.50	0.00	2.50	2.72
Dislivelli		-0.00	0.71	-0.03	-0.19	0.00

Sezione: 113
 Progressiva: 866.382
 Q. Progetto: 399.966

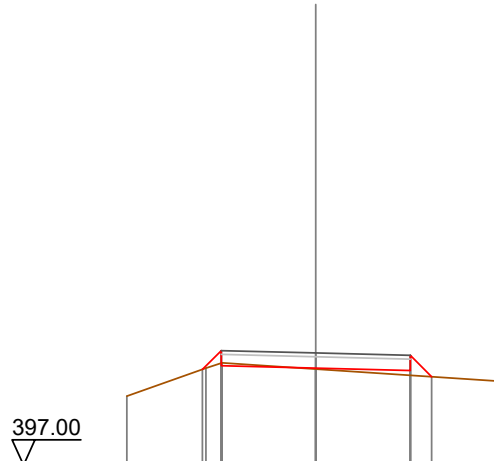

Quote Terreno	-398.82	-399.53	-399.71	-399.54		-399.20
Quote Progetto		399.63	399.71	399.57	399.50	399.34
Parziali		0.50	2.50	2.50	0.57	
Progressiva		-3.00	-2.50	0.00	2.50	3.07
Dislivelli		0.00	0.33	0.02	0.13	-0.00

Sezione: 114
 Progressiva: 870.000
 Q. Progetto: 399.969

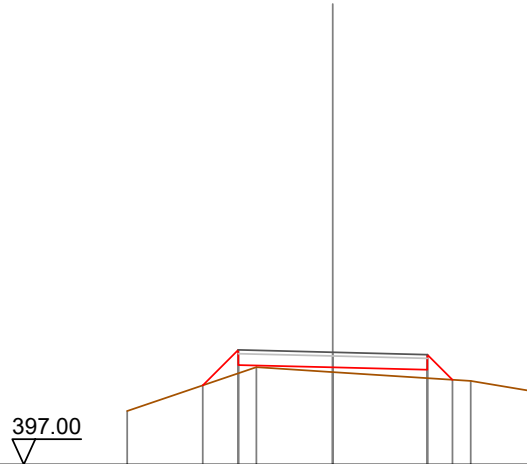

Quote Terreno		-398.42		-399.58		-399.44		-399.21		-398.95
Quote Progetto			399.09	399.63		399.57		399.51	399.24	
Parziali			0.94	2.50		2.50		0.67		
Progressiva			-3.44	-2.50		0.00		2.50	3.17	
Dislivelli			-0.00	0.62		0.12		0.22	0.00	

Sezione: 115
 Progressiva: 875.204
 Q. Progetto: 399.974

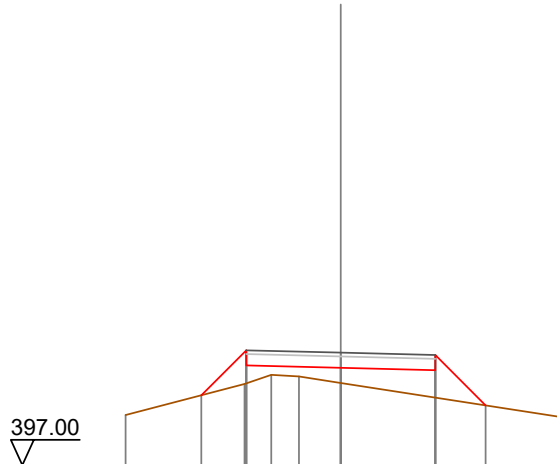

Quote Terreno		-398.33		-399.15		-399.34		-399.17		-398.27
Quote Progetto			398.85	399.64		399.39		399.57	399.51	398.58
Parziali			1.19	2.50		2.50		1.33		
Progressiva			-3.69	-2.50		0.00		2.50	3.83	
Dislivelli			-0.00	0.87		0.40		0.72	-0.00	

Sezione: 116
 Progressiva: 880.000
 Q. Progetto: 399.979

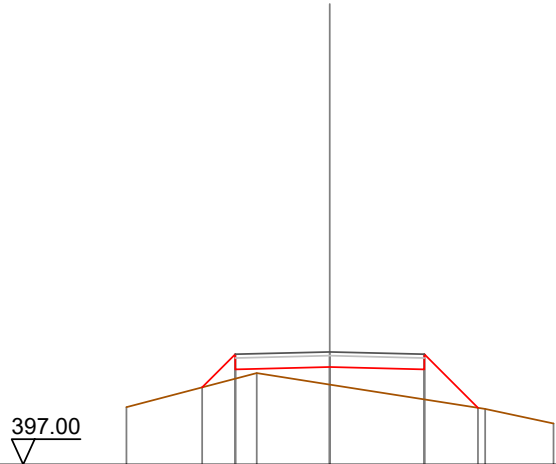

Quote Terreno		398.52		399.42		399.11		398.47		398.08
Quote Progetto			399.04	399.52		399.58		399.52		398.50
Parziali			0.88	2.50		2.50		1.42		
Progressiva			-3.38	-2.50		0.00		2.50		3.92
Dislivelli			0.00	0.65		0.46		0.80		-0.00

Sezione: 117
 Progressiva: 900.000
 Q. Progetto: 399.997

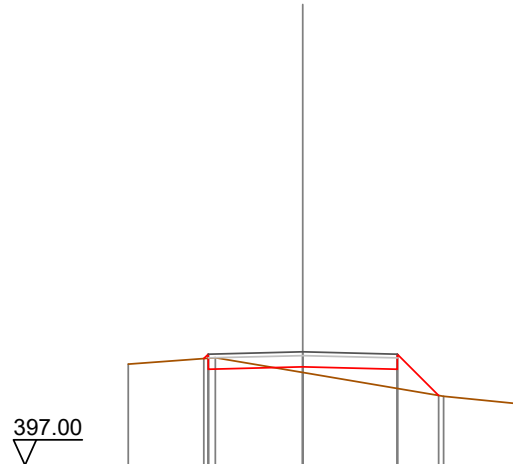

Quote Terreno		399.67		399.84		399.45		398.82		398.64
Quote Progetto			399.82	399.53		399.60		399.53		398.84
Parziali						2.50		2.50		1.09
Progressiva			-2.62	-2.50		0.00		2.50		3.59
Dislivelli			0.00	0.11		0.15		0.51		0.00

Sezione: 118
 Progressiva: 920.000
 Q. Progetto: 400.016

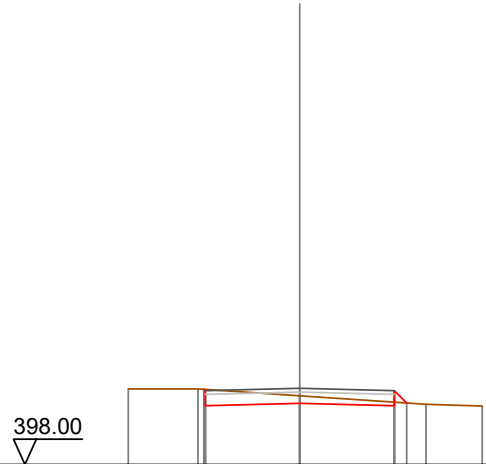

Quote Terreno	-400.00	400.00	399.82	399.59	-399.55
Quote Progetto		399.99 399.55	399.82	399.55 399.63	
Parziali		2.50	2.50	0.33	
Progressiva		-2.54 -2.50	0.00	2.50 2.83	
Dislivelli		0.00 -0.03	-0.20	-0.10 -0.00	

Sezione: 119
 Progressiva: 940.000
 Q. Progetto: 400.035

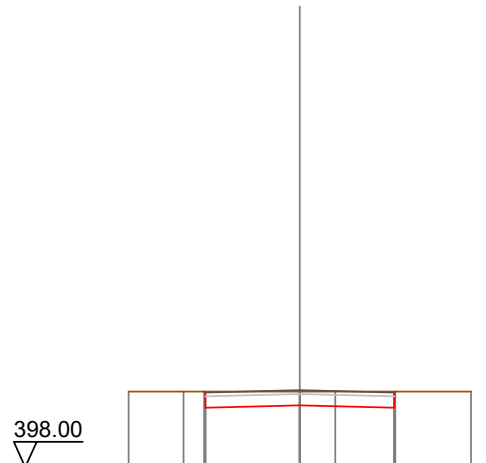

Quote Terreno	-400.00	400.00	400.00	400.00	400.00
Quote Progetto		400.00 399.57	399.63	399.57 400.00	
Parziali		2.50	2.50		
Progressiva		-2.53 -2.50	0.00	2.50 2.53	
Dislivelli		0.00 -0.03	-0.37	-0.43 0.00	

Sezione: 120
 Progressiva: 960.000
 Q. Progetto: 400.115

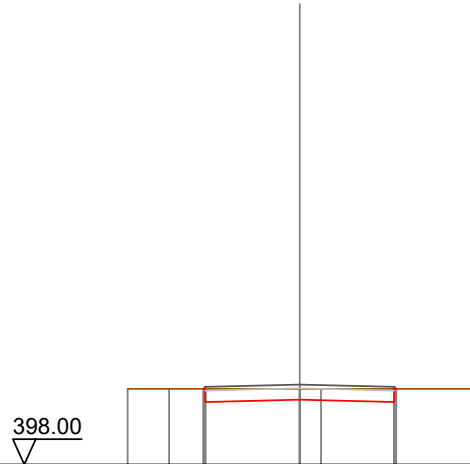

Quote Terreno		-400.00	-400.00	400.00	400.00	-400.00	-400.00
Quote Progetto			400.00	399.65	399.72	399.65	400.00
Parziali			2.50		2.50		
Progressiva			-2.55	-2.50	0.00	2.50	2.55
Dislivelli			-0.00	0.05	-0.28	-0.35	-0.00

Sezione: 121
 Progressiva: 970.854
 Q. Progetto: 400.414

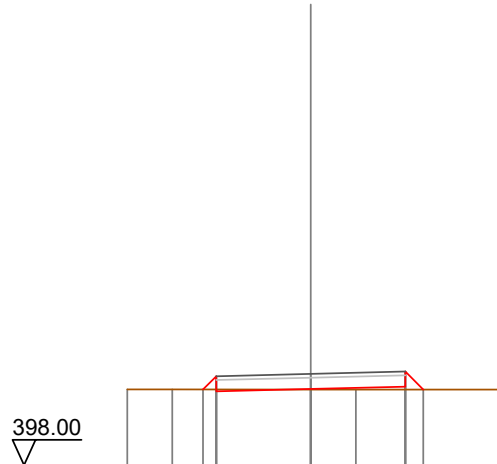

Quote Terreno		-400.00	-400.00	400.00	400.00	-400.00	-400.00
Quote Progetto			400.00	399.95	400.01	400.08	400.00
Parziali			0.35	2.50	2.50	0.48	
Progressiva			-2.95	-2.50	0.00	2.50	2.98
Dislivelli			0.00	0.35	0.01	0.08	-0.00

Sezione: 122
 Progressiva: 975.446
 Q. Progetto: 400.611

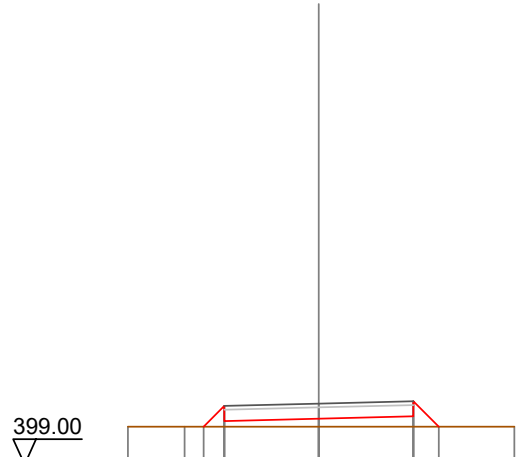

Quote Terreno	-400.00	-400.00	400.00	400.00	-400.00	
Quote Progetto		400.00	400.15	400.21	400.27	400.00
Parziali		0.55	2.50	2.50	0.67	
Progressiva		-3.05	-2.50	0.00	2.50	3.17
Dislivelli		-0.00	0.55	0.21	0.27	0.00

Sezione: 123
 Progressiva: 980.039
 Q. Progetto: 400.851

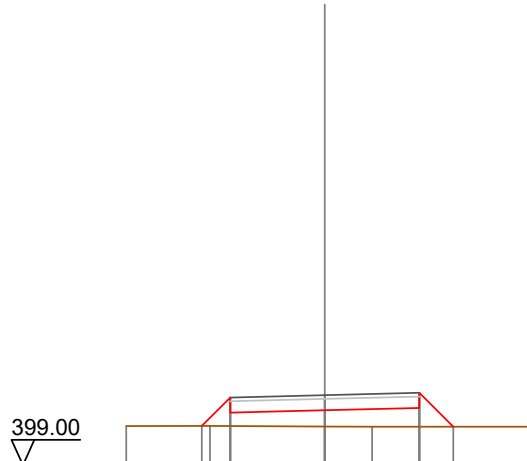

Quote Terreno	-400.03	-400.04	400.02	400.02	-400.02	
Quote Progetto		400.04	400.39	400.45	400.51	400.02
Parziali		0.75	2.50	2.50	0.90	
Progressiva		-3.25	-2.50	0.00	2.50	3.40
Dislivelli		-0.00	0.75	0.43	0.50	0.00

Sezione: 124
 Progressiva: 1000.000
 Q. Progetto: 402.220

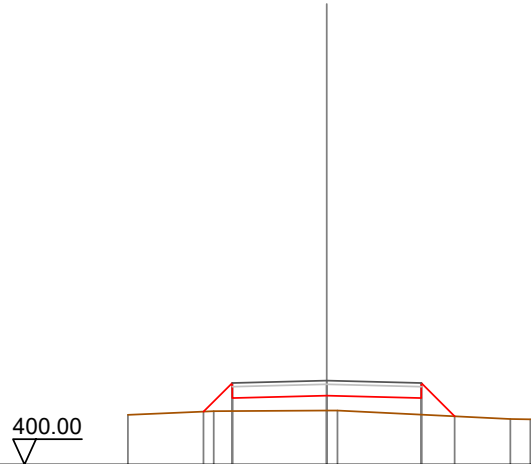

Quote Terreno		-401.31		401.41		401.43		401.43		401.20		401.19
Quote Progetto			401.40	401.76		401.82		401.76	401.28			
Parziali			0.76	2.50		2.50		0.88				
Progressiva			-3.26	-2.50		0.00		2.50	3.38			
Dislivelli			0.00	0.75		0.39		0.44	0.00			

Sezione: 125
 Progressiva: 1020.000
 Q. Progetto: 403.170

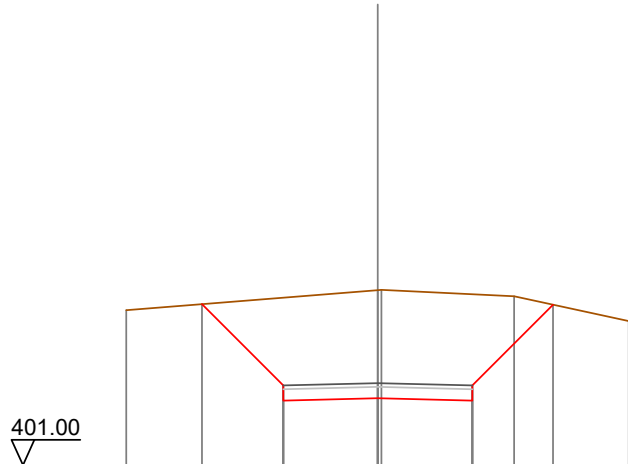

Quote Terreno		405.10				405.63		405.63		405.47		404.81
Quote Progetto			405.26	402.71		402.77		402.71	405.24			
Parziali			2.15	2.50		2.50		2.14				
Progressiva			-4.65	-2.50		0.00		2.50	4.64			
Dislivelli			0.00	-2.32		-2.86		-2.81	-0.00			

Sezione: 126
 Progressiva: 1037.588
 Q. Progetto: 403.343

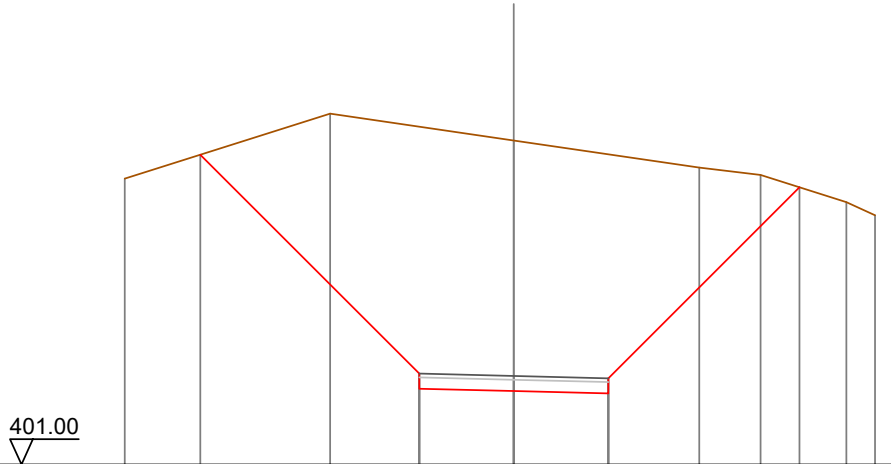

Quote Terreno	-408.56	-410.28	-409.57	-408.86	-408.66	-407.94	-407.59
Quote Progetto	409.19	403.01	402.94	402.88	408.33		
Parziali		5.79	2.50	2.50	5.05		
Progressiva	-8.29	-2.50	0.00	2.50	7.55		
Dislivelli	0.00	-6.53	-6.63	-6.33	0.00		

Sezione: 127
 Progressiva: 1040.000
 Q. Progetto: 403.318

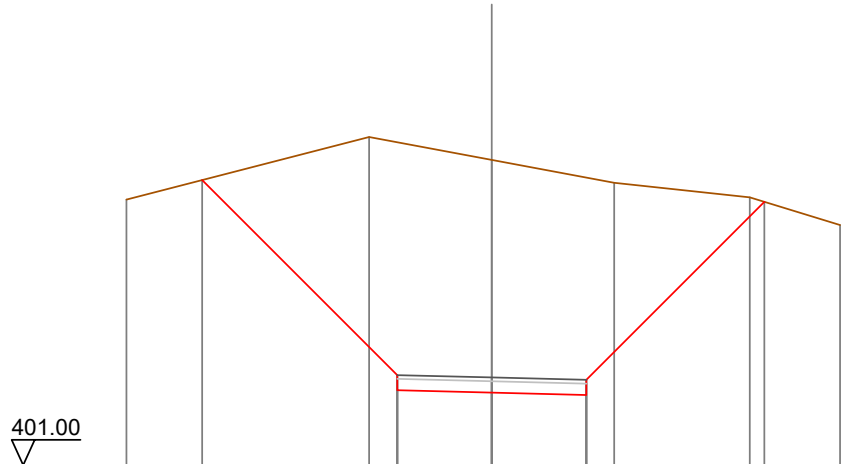

Quote Terreno	-408.03	-409.68	-409.07	-408.47	-408.08	-407.35
Quote Progetto	408.54	402.98	402.92	402.86	407.96	
Parziali		5.16	2.50	2.50	4.71	
Progressiva	-7.66	-2.50	0.00	2.50	7.21	
Dislivelli	0.00	-6.16	-6.15	-5.75	0.00	

Sezione: 128
 Progressiva: 1044.364
 Q. Progetto: 403.244

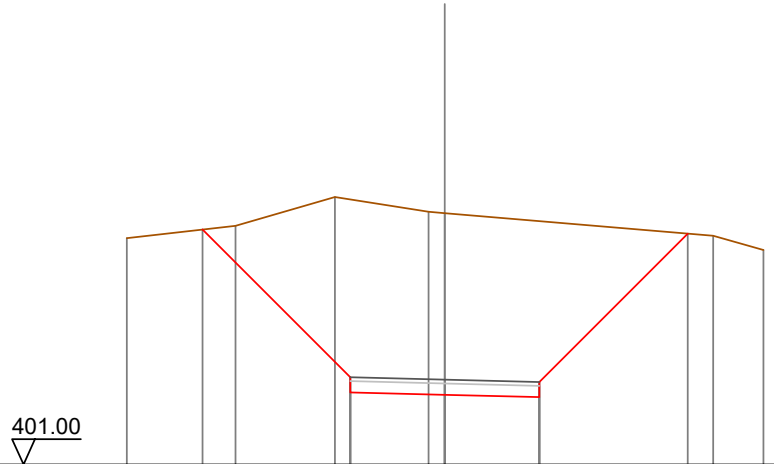

Quote Terreno	-406.99	-407.31	-408.08	-407.68	-407.65	-407.05	-406.67
Quote Progetto		407.21	402.91	402.84	402.78	407.11	
Parziali			3.91	2.50	2.50	3.93	
Progressiva		-6.41	-2.50	0.00	2.50	6.43	
Dislivelli		0.00	-4.70	-4.80	-4.66	0.00	

Sezione: 129
 Progressiva: 1050.000
 Q. Progetto: 403.092

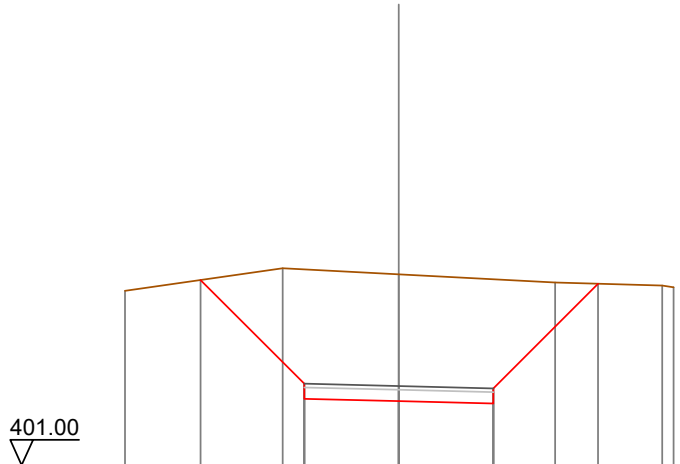

Quote Terreno	-405.61	-406.21	-406.05	-405.83	-405.75	-405.70
Quote Progetto		405.90	402.75	402.69	402.63	405.80
Parziali		2.74	2.50	2.50	2.77	
Progressiva		-5.24	-2.50	0.00	2.50	5.27
Dislivelli		-0.00	-3.02	-3.35	-3.29	0.00

Sezione: 130
 Progressiva: 1051.140
 Q. Progetto: 403.054

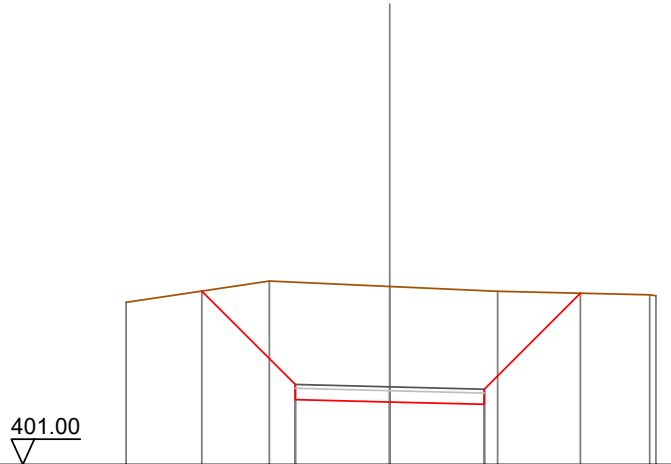

Quote Terreno	-405.29	-405.85	-405.71	-405.58	-405.49	-405.46
Quote Progetto		405.59	402.72	402.66	402.59	405.53
Parziali		2.47	2.50	2.50	2.54	
Progressiva		-4.97	-2.50	0.00	2.50	5.04
Dislivelli		0.00	-2.71	-3.06	-3.01	0.00

Sezione: 131
 Progressiva: 1060.000
 Q. Progetto: 402.666

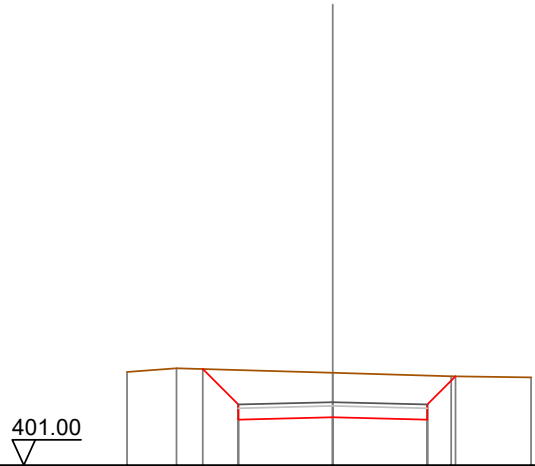

Quote Terreno	-403.46	-403.56	-403.44	-403.35	-403.32	
Quote Progetto		403.54	402.27	402.20	403.35	
Parziali		0.94	2.50	2.50	0.75	
Progressiva		-3.44	-2.50	0.00	2.50	3.25
Dislivelli		0.00	-0.91	-1.18	-1.17	-0.00

Sezione: 132
 Progressiva: 1080.000
 Q. Progetto: 401.245

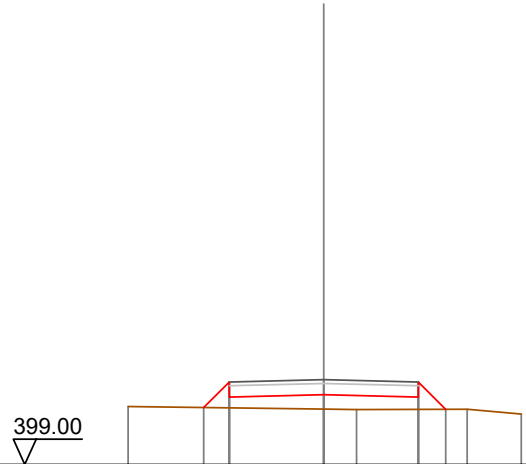

Quote Terreno		-400.54			400.46	-400.45		400.46	-400.46	-400.34
Quote Progetto			400.51	400.78	400.85		400.78	400.46		
Parziali			0.67	2.50		2.50	0.72			
Progressiva			-3.17	-2.50	0.00		2.50	3.22		
Dislivelli			-0.00	0.68		0.38	0.33	0.00		

Sezione: 133
 Progressiva: 1100.000
 Q. Progetto: 399.624

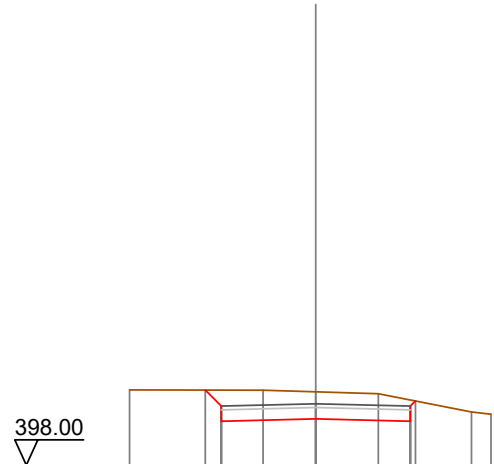

Quote Terreno		399.99			399.98	399.94		399.89	399.41	399.35
Quote Progetto			399.98	399.16		399.22		399.16	399.70	
Parziali			0.42	2.50		2.50				
Progressiva			-2.92	-2.50	0.00		2.50	2.64		
Dislivelli			0.00	-0.42		-0.72	-0.56	0.00		

Sezione: 134
 Progressiva: 1120.000
 Q. Progetto: 398.361

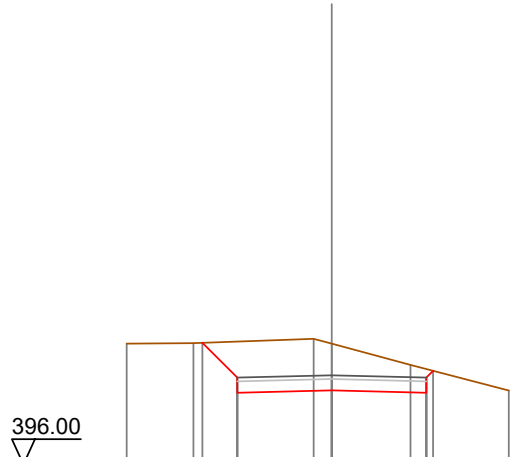

Quote Terreno		399.20	399.21		399.33	399.20	398.63		397.96
Quote Progetto			399.22	397.90		397.96	397.90	398.48	
Parziali			0.92	2.50		2.50			
Progressiva			-3.42	-2.50		0.00	2.50	2.68	
Dislivelli			0.00	-0.96		-1.23	-0.63	0.00	

Sezione: 135
 Progressiva: 1121.161
 Q. Progetto: 398.312

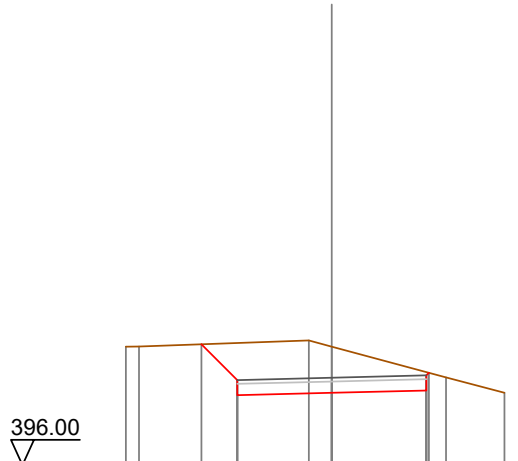

Quote Terreno		398.13	398.14		398.30	398.13	398.32		397.91
Quote Progetto			399.20	397.65		397.91	397.97	398.44	
Parziali			0.95	2.50		2.50			
Progressiva			-3.45	-2.50		0.00	2.50	2.57	
Dislivelli			0.00	-0.98		-1.22	-0.48	0.00	

Sezione: 136
 Progressiva: 1123.470
 Q. Progetto: 398.223

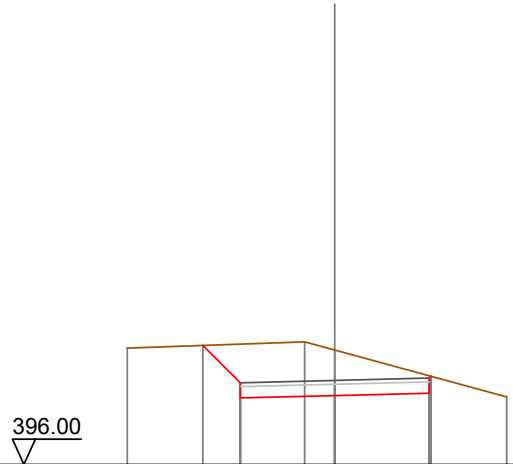

Quote Terreno		399.08		399.24	399.03		397.79
Quote Progetto			399.15	397.76	397.82	397.89	398.33
Parziali			0.99	2.50	2.50		
Progressiva			-3.49	-2.50	0.00	2.50	2.55
Dislivelli			0.00	-1.02	-1.20	-0.46	-0.00

Sezione: 137
 Progressiva: 1125.778
 Q. Progetto: 398.145

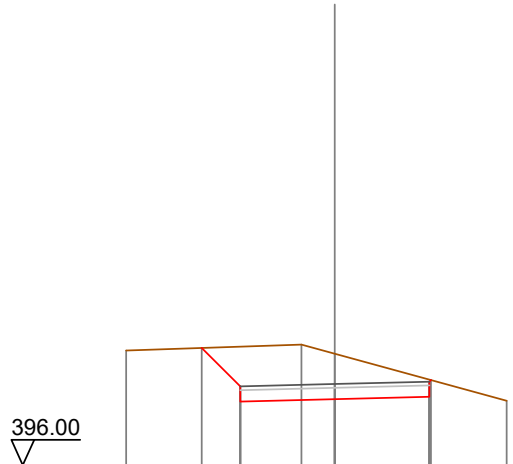

Quote Terreno		399.03		399.19	398.95		397.70
Quote Progetto			399.10	397.68	397.74	397.81	398.25
Parziali			1.02	2.50	2.50		
Progressiva			-3.52	-2.50	0.00	2.50	2.54
Dislivelli			-0.00	-1.05	-1.20	-0.46	0.00

Sezione: 138
 Progressiva: 1140.000
 Q. Progetto: 397.730

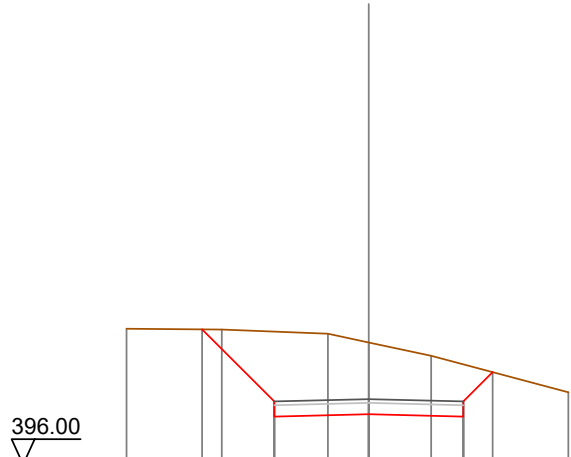

Quote Terreno		399.59	399.57	399.46	399.23	398.88		397.91
Quote Progetto			399.58	397.27	397.33	397.27	398.44	
Parziali			1.91	2.50	2.50	0.78		
Progressiva			-4.41	-2.50	0.00	2.50	3.28	
Dislivelli			-0.00	-1.85	-1.90	-1.38	0.00	

Sezione: 139
 Progressiva: 1160.000
 Q. Progetto: 396.557

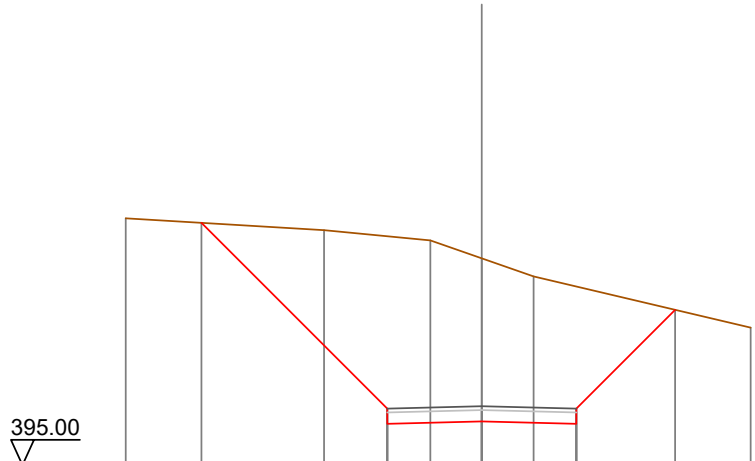

Quote Terreno		401.53	401.22	400.95	400.47	399.99		398.63
Quote Progetto			401.41	396.09	396.16	396.09	398.11	
Parziali			4.91	2.50	2.50	2.61		
Progressiva			-7.41	-2.50	0.00	2.50	5.11	
Dislivelli			0.00	-4.56	-4.31	-3.63	0.00	

Sezione: 140
 Progressiva: 1176.042
 Q. Progetto: 395.032

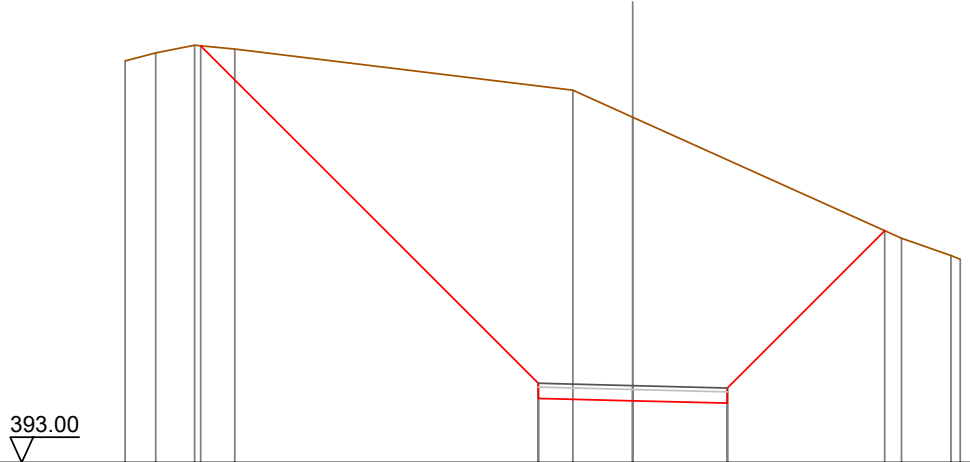

Quote Terreno	403.62	403.84	404.04	403.94		402.85	402.13		398.93	398.48	398.37
Quote Progetto			404.02			394.69	394.63	394.57	399.13		
Parziali					8.93		2.50	2.50	4.16		
Progressiva			-11.43			-2.50	0.00	2.50	6.66		
Dislivelli			0.00			-7.87	-7.50	-6.44	0.00		

Sezione: 141
 Progressiva: 1176.502
 Q. Progetto: 394.981

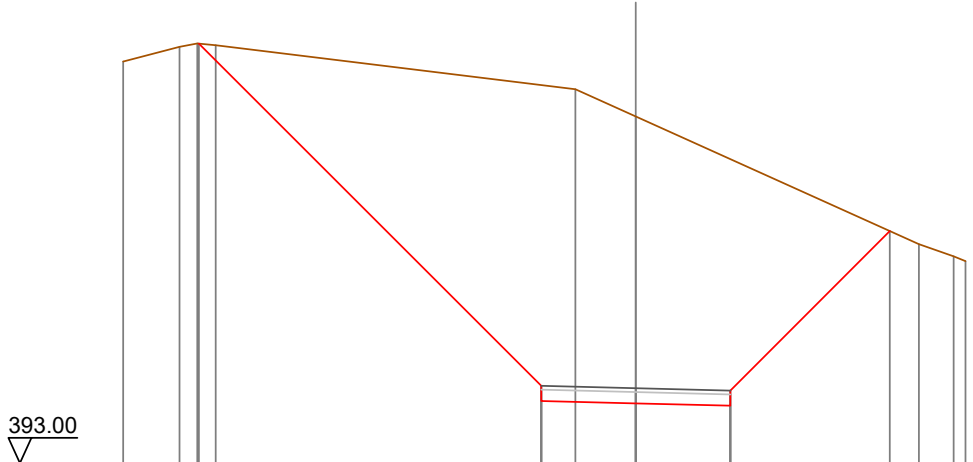

Quote Terreno	403.62	404.01	404.10	404.05		402.89	402.17		398.79	398.47	398.34
Quote Progetto			404.10			394.64	394.58	394.52	399.14		
Parziali					9.05		2.50	2.50	4.22		
Progressiva			-11.55			-2.50	0.00	2.50	6.72		
Dislivelli			0.00			-7.96	-7.59	-6.52	0.00		

Sezione: 142
 Progressiva: 1176.963
 Q. Progetto: 394.929

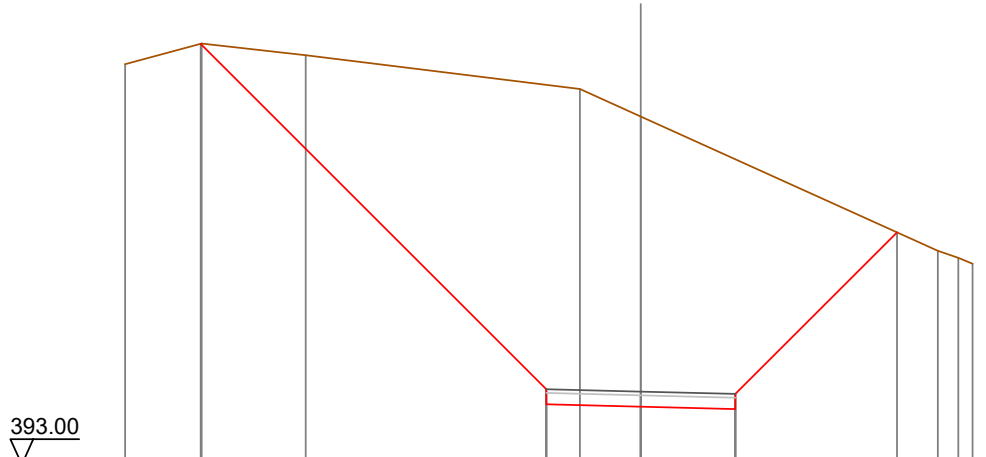

Quote Terreno	-403.59	-404.13	-403.83	-402.93	-402.21	-398.65	-398.47	-398.31
Quote Progetto		404.13		394.59	394.53	394.47	399.14	
Parziali			9.14	2.50	2.50	4.27		
Progressiva		-11.64		-2.50	0.00	2.50	6.77	
Dislivelli		-0.00		-8.05	-7.68	-6.61	0.00	

Sezione: 143
 Progressiva: 1180.000
 Q. Progetto: 394.585

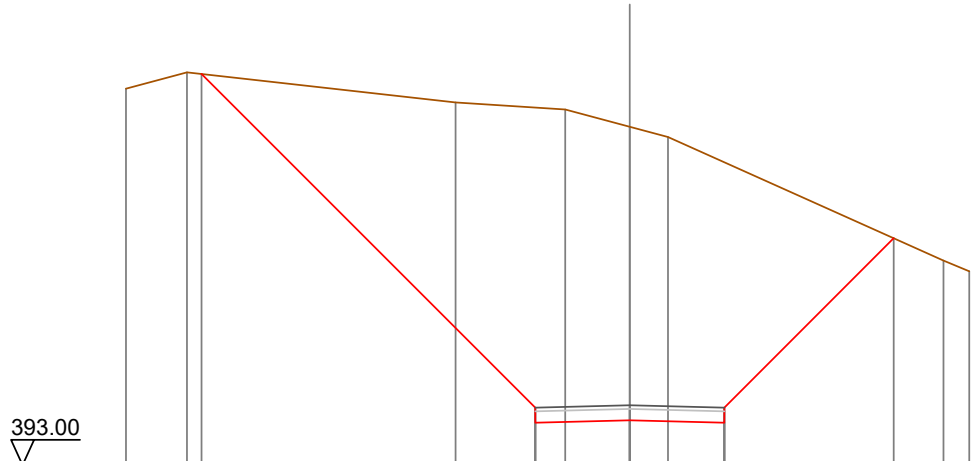

Quote Terreno	-402.96	-403.39	-402.59	-402.41	-401.95	-401.68	-398.41	-398.13
Quote Progetto		403.35		394.12	394.18	394.12	399.00	
Parziali			8.83	2.50	2.50	4.48		
Progressiva		-11.33		-2.50	0.00	2.50	6.98	
Dislivelli		0.00		-7.94	-7.77	-6.69	-0.00	

Sezione: 144
 Progressiva: 1200.000
 Q. Progetto: 392.758

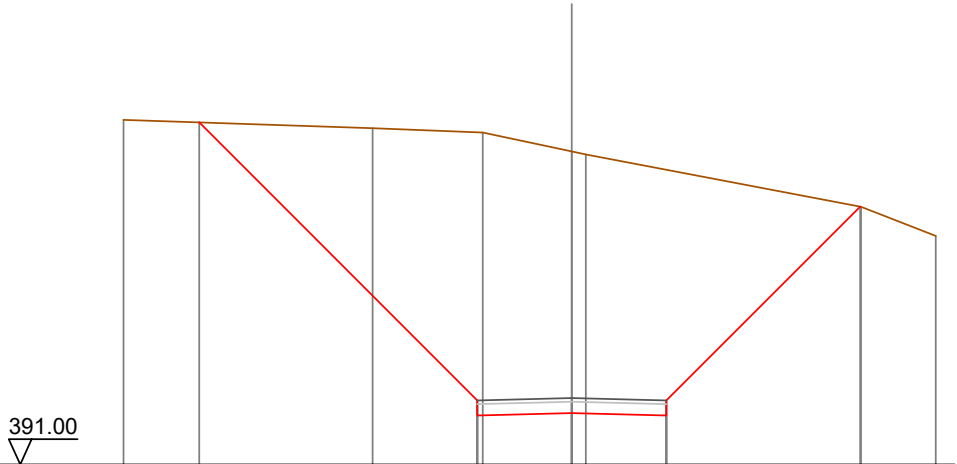

Quote Terreno		400.12		399.90		399.78		399.28		399.20		397.82		397.05
Quote Progetto			400.05			392.30		392.36		392.30		397.82		
Parziali				7.35			2.50		2.50		5.13			
Progressiva			-9.85			-2.50		0.00		2.50		7.63		
Dislivelli			0.00			-7.09		-6.92		-6.50		0.00		

Sezione: 145
 Progressiva: 1220.000
 Q. Progetto: 391.739

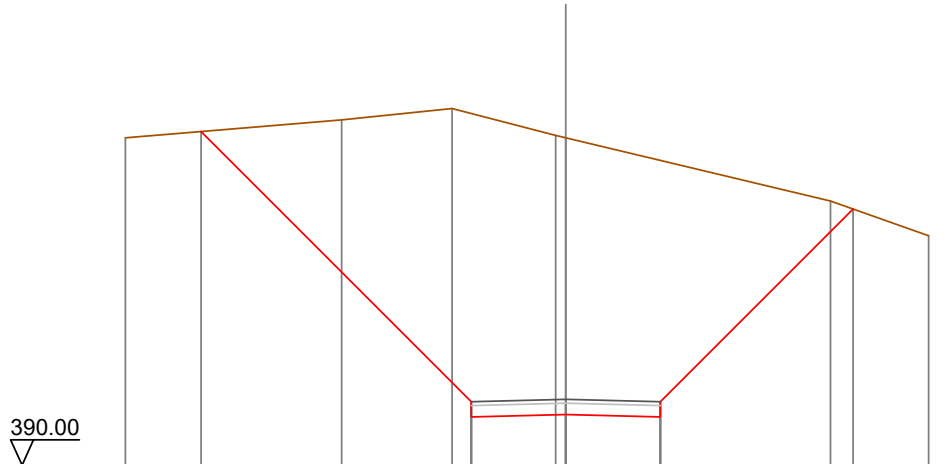

Quote Terreno		398.66		398.13		398.43		398.72		398.66		396.98		396.07
Quote Progetto			398.82			391.28		391.34		391.28		396.77		
Parziali				7.15			2.50		2.50		5.10			
Progressiva			-9.65			-2.50		0.00		2.50		7.60		
Dislivelli			0.00			-7.63		-7.32		-6.78		-0.00		

Sezione: 146
 Progressiva: 1226.591
 Q. Progetto: 391.579

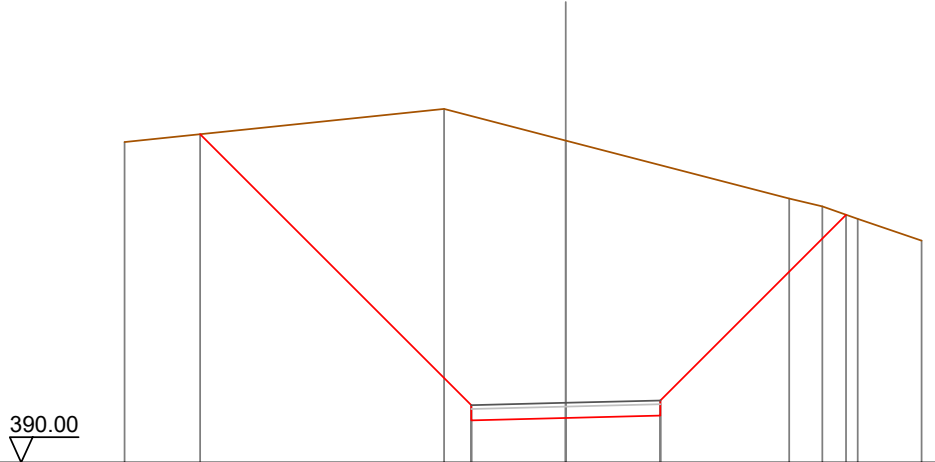

Quote Terreno		-398.48			-399.35					-396.98	-396.77	-396.44	-395.87
Quote Progetto			398.69			391.12		391.18	398.52		391.24		
Parziali				7.17			2.50		2.50		4.91		
Progressiva			-9.67			-2.50		0.00		2.50		7.41	
Dislivelli			0.00			-7.65		-7.34		-6.63		0.00	

Sezione: 147
 Progressiva: 1230.000
 Q. Progetto: 391.530

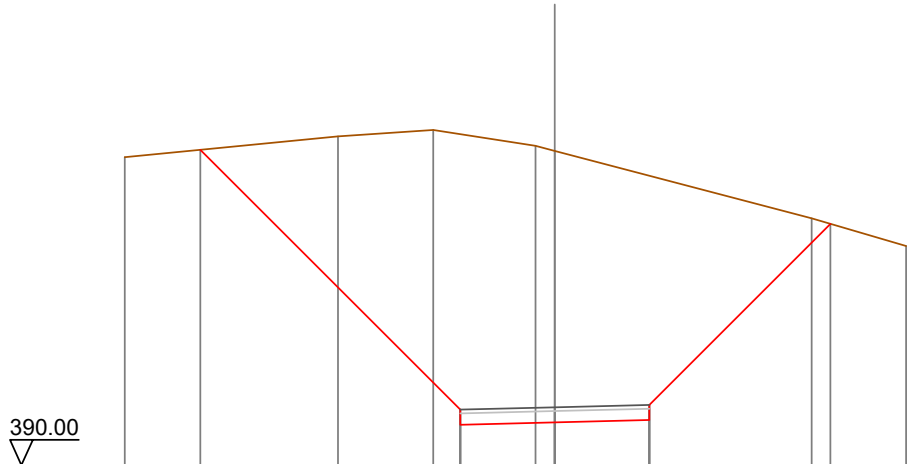

Quote Terreno		-398.15			-398.69							-396.53	-395.79
Quote Progetto			398.34				391.07		398.44	398.31		391.19	
Parziali				6.87				2.50		2.50		4.79	
Progressiva			-9.37				-2.50		0.00		2.50		7.29
Dislivelli			0.00				-7.29		-7.18		-6.46		0.00

Sezione: 148
 Progressiva: 1238.113
 Q. Progetto: 391.500

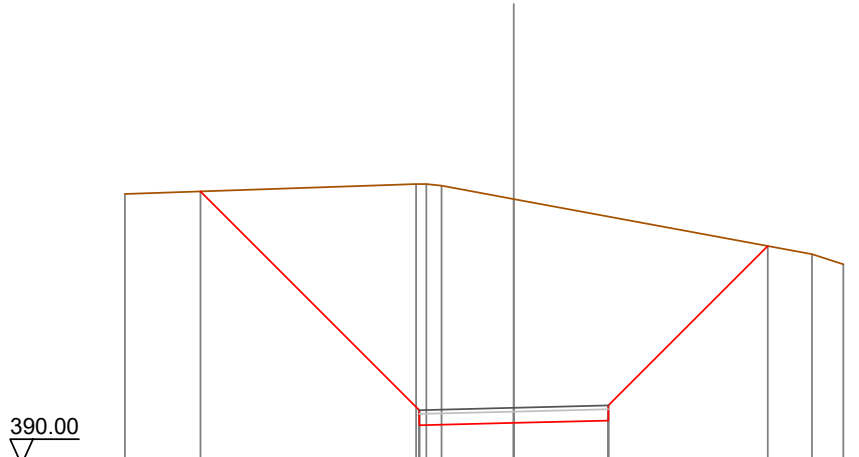

Quote Terreno	397.15		397.42	397.37	397.02		395.56	395.29
Quote Progetto		397.22	391.04		391.10	391.16	395.78	
Parziali		5.78	2.50	2.50	4.22			
Progressiva		-8.28	-2.50	0.00	2.50		6.72	
Dislivelli		0.00	-5.98	-5.92	-5.40		0.00	

SEZIONI TRASVERSALI
Profilo longitudinale tratto 8-15
Viabilità di impianto-Postazione aerogeneratore VI05

Nota: Le canalette di deflusso delle acque meteoriche, non indicate nel presente elaborato, sono rappresentate graficamente nelle sezioni stradali tipo dell'elaborato "SR-VI-TC12_Piazzole aerogeneratori e strade di servizio - Particolari costruttivi", individuate planimetricamente nell'elaborato "SR-VI-TC13_Opere di regimazione acque superficiali - Planimetria generale" e quantificate nell'elaborato "SR-VI-RC6_Computo Metrico Estimativo opere civili".

DISEGNI DI RIFERIMENTO

TAVOLA	DESCRIZIONE
SR-VI-TC8.1	Piazzole e viabilità - Planimetria di progetto - Fase di cantiere
SR-VI-TC10	Profili longitudinali viabilità di impianto
SR-VI-TC12	Piazzole aerogeneratori e strade di servizio - Particolari costruttivi
SR-VI-TC13	Opere di regimazione acque superficiali - Planimetria generale

Sezione: 2
 Progressiva: 9.190
 Q. Progetto: 454.330

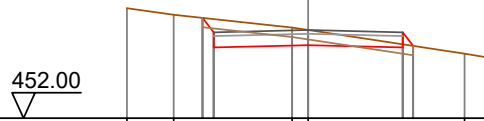

Quote Terreno	-454.91	-454.73	-454.40	-454.33	-453.70	-453.60
Quote Progetto		454.65 453.87	453.93	453.87 453.91		
Parziali		0.28 2.50	2.50	0.27		
Progressiva		-2.79 -2.50	0.00	2.50 2.77		
Dislivelli		0.00 -0.35	-0.40	-0.08 -0.00		

Sezione: 3
 Progressiva: 20.000
 Q. Progetto: 453.764

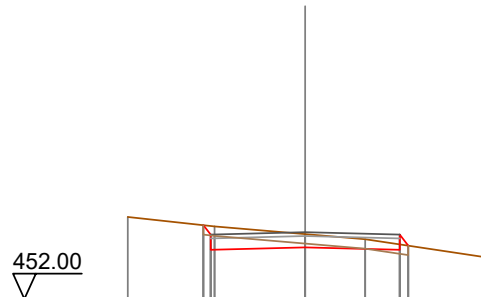

Quote Terreno	-454.17	-453.92	-453.71	-453.58	-453.11
Quote Progetto		453.95 453.30	453.36	453.30 453.41	
Parziali		2.50	2.50		
Progressiva		-2.69 -2.50	0.00	2.50 2.73	
Dislivelli		0.00 -0.23	-0.35	-0.14 0.00	

Sezione: 4
 Progressiva: 26.227
 Q. Progetto: 453.438

451.00

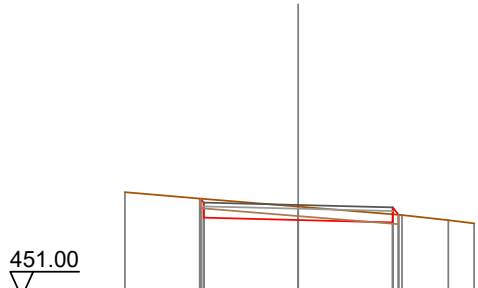

Quote Terreno	-453.77	-453.61	-453.39	-453.17	-453.03	-452.95
Quote Progetto		453.60 453.10	453.04	452.98 453.18		
Parziali		2.50	2.50			
Progressiva		-2.58 -2.50	0.00	2.50 2.65		
Dislivelli		0.00 -0.10	-0.36	-0.22 0.00		

Sezione: 5
 Progressiva: 30.000
 Q. Progetto: 453.244

451.00

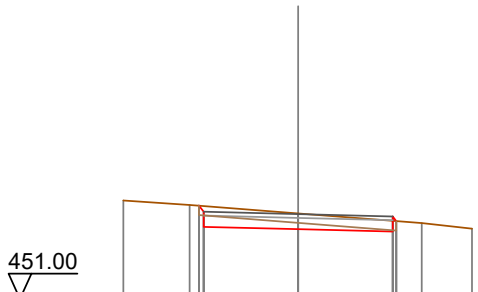

Quote Terreno	-453.60	-453.49	-453.26	-453.00	-452.86
Quote Progetto		453.47 452.91	452.84	452.78 453.06	
Parziali		2.50	2.50		
Progressiva		-2.62 -2.50	0.00	2.50 2.60	
Dislivelli		0.00 -0.15	-0.42	-0.28 0.00	

Sezione: 6
 Progressiva: 40.000
 Q. Progetto: 452.858

451.00

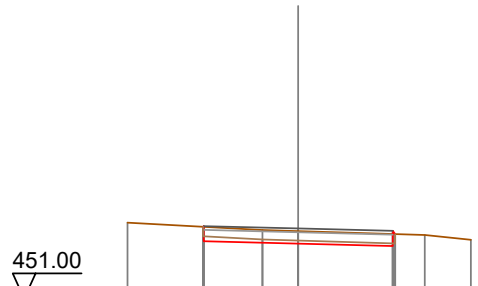

Quote Terreno	-453.01	-452.82	-452.79	-452.69	-452.56
Quote Progetto		452.52	452.46	452.40 452.71	
Parziali		2.50	2.50		
Progressiva		-2.51	0.00	2.50 2.57	
Dislivelli		0.00	-0.33	-0.32 -0.00	

Sezione: 7
 Progressiva: 42.504
 Q. Progetto: 452.793

451.00

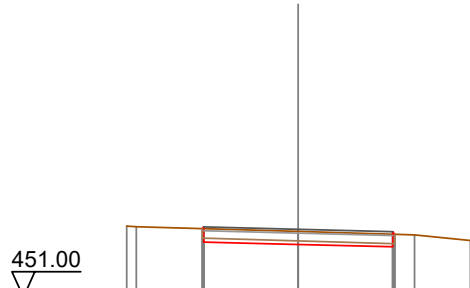

Quote Terreno	452.88	452.86	452.74	452.65	452.50
Quote Progetto	452.81	452.46	452.39	452.33	452.66
Parziali		2.50	2.50		
Progressiva	-2.53	-2.50	0.00	2.50	2.55
Dislivelli	0.00	0.04	-0.34	-0.33	0.00

Sezione: 8
 Progressiva: 50.000
 Q. Progetto: 452.672

451.00

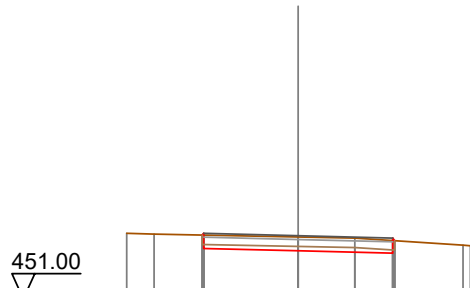

Quote Terreno	452.73	452.71	452.64	452.61	452.42	452.40
Quote Progetto	452.69	452.33	452.27	452.21	452.54	
Parziali		2.50	2.50			
Progressiva	-2.54	-2.50	0.00	2.50	2.55	
Dislivelli	0.00	0.05	-0.37	-0.33	0.00	

Sezione: 9
 Progressiva: 58.782
 Q. Progetto: 452.675

451.00

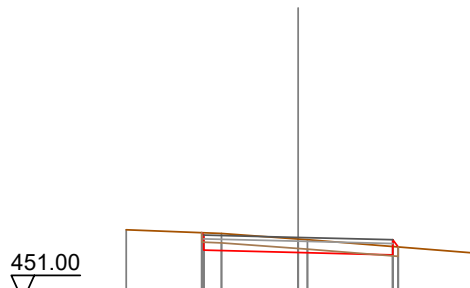

Quote Terreno	452.88	452.78	452.63	452.61	452.26
Quote Progetto	452.80	452.34	452.27	452.21	452.42
Parziali		2.50	2.50		
Progressiva	-2.55	-2.50	0.00	2.50	2.65
Dislivelli	0.00	-0.06	-0.36	-0.22	-0.00

Sezione: 10
 Progressiva: 60.000
 Q. Progetto: 452.687

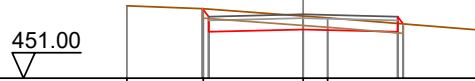

Quote Terreno	-452.91	-452.83	-452.64	-452.59	-452.27
Quote Progetto	-452.84	-452.22	-452.29	-452.22	-452.43
Parziali		2.50	2.50		
Progressiva	-2.66	-2.50	0.00	2.50	2.65
Dislivelli	0.00	-0.20	-0.35	-0.22	0.00

Sezione: 11
 Progressiva: 80.000
 Q. Progetto: 452.949

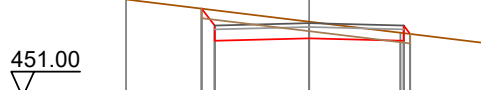

Quote Terreno	-453.58	-453.33	-452.99	-452.70	-452.42
Quote Progetto	-453.33	-452.49	-452.55	-452.49	-452.67
Parziali		0.34	2.50	2.50	
Progressiva	-2.84	-2.50	0.00	2.50	2.67
Dislivelli	0.00	-0.41	-0.44	-0.20	0.00

Sezione: 12
 Progressiva: 100.000
 Q. Progetto: 453.212

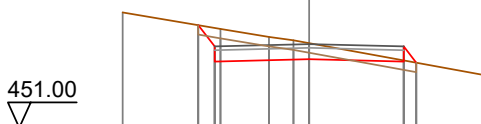

Quote Terreno	-454.05	-453.71	-453.40	-453.31	-452.75
Quote Progetto	-453.71	-452.75	-452.81	-452.75	-452.72
Parziali		0.43	2.50	2.50	0.33
Progressiva	-2.93	-2.50	0.00	2.50	2.83
Dislivelli	0.00	-0.49	-0.42	-0.03	-0.00

Sezione: 13
 Progressiva: 101.050
 Q. Progetto: 453.226

451.00

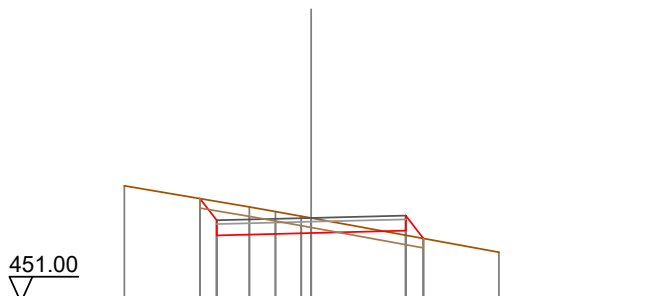

Quote Terreno	-454.07	-453.74	-453.52	-453.40	-453.27	-453.22	-452.32
Quote Progetto		453.74	452.76		452.83		452.89
Parziali		0.44	2.50		2.50		0.47
Progressiva		-2.94	-2.50		0.00		2.50
Dislivelli		0.00	-0.50		-0.40		0.12
							0.00

Sezione: 14
 Progressiva: 101.876
 Q. Progetto: 453.237

451.00

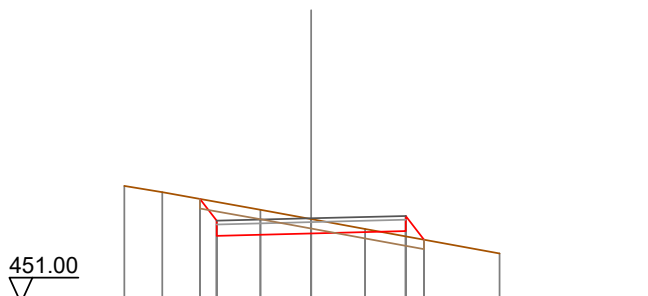

Quote Terreno	-454.10	-453.93	-453.46	-453.22	-452.96	-452.31
Quote Progetto		453.75	452.77	452.84	452.90	452.67
Parziali		0.44	2.50		2.50	0.48
Progressiva		-2.94	-2.50	0.00	2.50	2.98
Dislivelli		0.00	-0.50	-0.38	0.14	-0.00

Sezione: 15
 Progressiva: 102.703
 Q. Progetto: 453.248

451.00

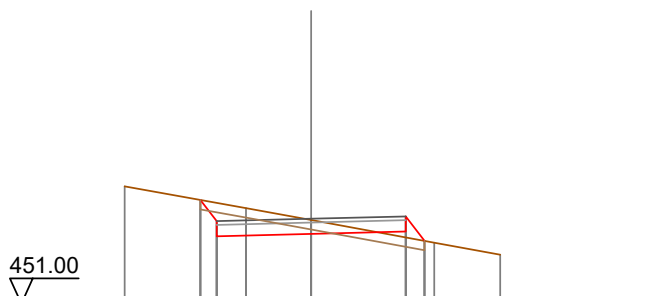

Quote Terreno	-454.10	-453.75	-453.53	-453.21	-452.62	-452.30
Quote Progetto		453.75	452.79	452.85	452.91	452.66
Parziali		0.43	2.50		2.50	0.50
Progressiva		-2.93	-2.50	0.00	2.50	3.00
Dislivelli		0.00	-0.48	-0.37	0.16	0.00

Sezione: 16
 Progressiva: 120.000
 Q. Progetto: 453.476

450.00

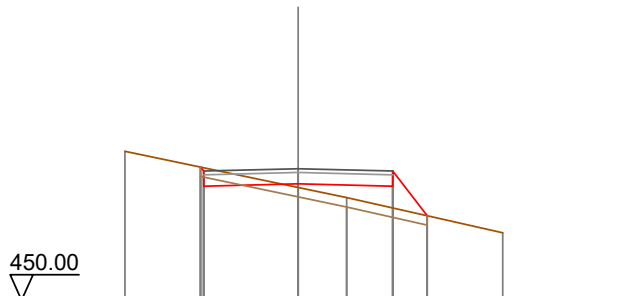

Quote Terreno	-453.94	-452.98	-452.71	-451.78
Quote Progetto	453.52 453.01	453.08	453.01	452.23
Parziali		2.50	2.50	0.91
Progressiva	-2.58 -2.50	0.00	2.50	3.41
Dislivelli	-0.00 -0.09	0.10	0.58	0.00

Sezione: 17
 Progressiva: 140.000
 Q. Progetto: 453.739

449.00

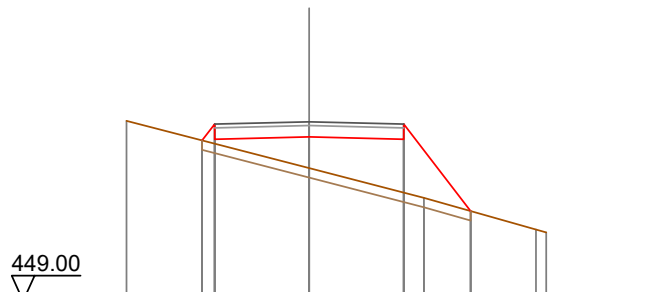

Quote Terreno	-453.76	-452.51	-451.73	-450.89 -450.81
Quote Progetto	453.25 453.28	453.34	453.28	451.38
Parziali	0.33	2.50	2.50	1.77
Progressiva	-2.83 -2.50	0.00	2.50	4.27
Dislivelli	0.00 0.52	0.83	1.41	-0.00

Sezione: 18
 Progressiva: 160.000
 Q. Progetto: 454.276

448.00

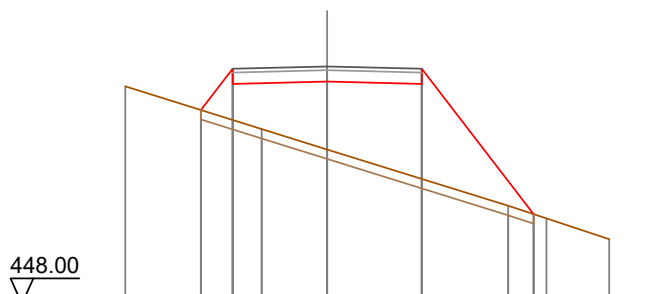

Quote Terreno	-453.75	-452.62	-452.08	-450.69 -450.26	-449.71
Quote Progetto	453.12 453.81	453.88	453.81	450.37	
Parziali	0.84	2.50	2.50	2.96	
Progressiva	-3.34 -2.50	0.00	2.50	5.46	
Dislivelli	-0.00 1.35	1.80	2.51	-0.00	

Sezione: 19
 Progressiva: 175.816
 Q. Progetto: 455.261

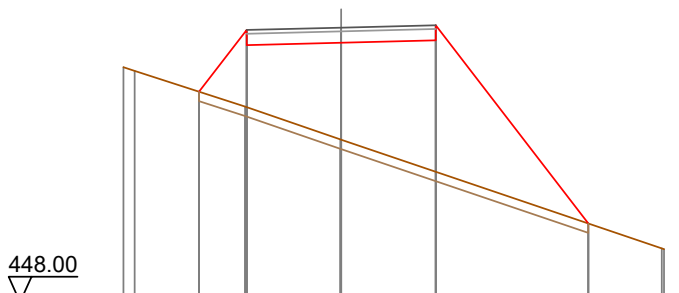

Quote Terreno		454.21	454.11					449.42	449.40
Quote Progetto			453.56	454.80	453.17	454.86	454.92	450.08	
Parziali			1.26	2.50		2.50	4.04		
Progressiva			-3.76	-2.50	0.00	2.50		6.54	
Dislivelli			0.00	2.04	2.56	3.47		-0.00	

Sezione: 20
 Progressiva: 177.750
 Q. Progetto: 455.415

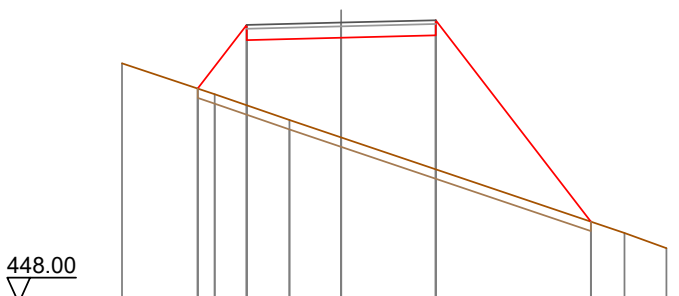

Quote Terreno		454.34	453.52	452.84	452.38			449.85	449.45
Quote Progetto			453.67	454.95	455.02	455.08		450.15	
Parziali			1.29	2.50	2.50	4.10			
Progressiva			-3.79	-2.50	0.00	2.50		6.60	
Dislivelli			0.00	2.12	2.64	3.54		0.00	

Sezione: 21
 Progressiva: 179.684
 Q. Progetto: 455.578

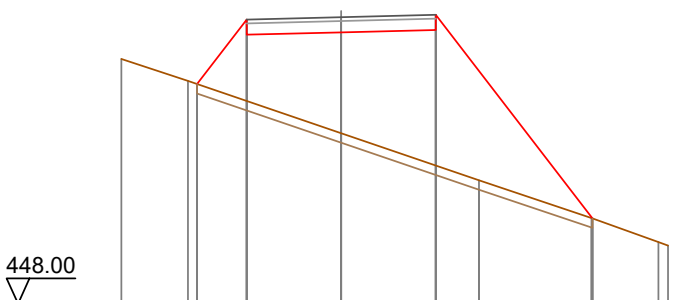

Quote Terreno		454.47	453.89		452.51		451.26	450.27	449.63	449.54
Quote Progetto			453.81	455.12	455.18	455.24		450.26		
Parziali			1.31	2.50	2.50	4.15				
Progressiva			-3.81	-2.50	0.00	2.50		6.65		
Dislivelli			0.00	2.15	2.67	3.59		0.00		

Sezione: 22
 Progressiva: 180.000
 Q. Progetto: 455.605

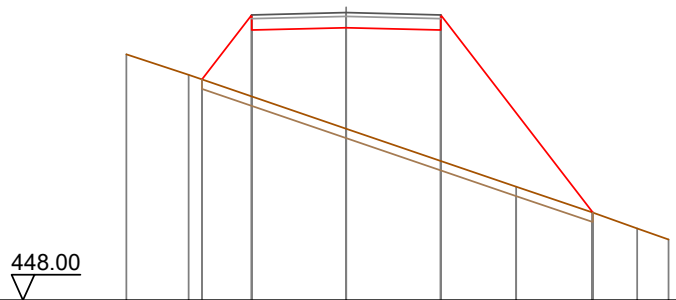

Quote Terreno	-454.50	-453.96		-452.53		-451.00	-450.32	-449.90	-449.60
Quote Progetto		-453.84	-455.14	-455.21	-455.14		-450.32		
Parziali		1.31	2.50	2.50	4.02				
Progressiva		-3.81	-2.50	0.00	2.50		6.52		
Dislivelli		0.00	2.15	2.67	3.46		-0.00		

Sezione: 23
 Progressiva: 200.000
 Q. Progetto: 457.743

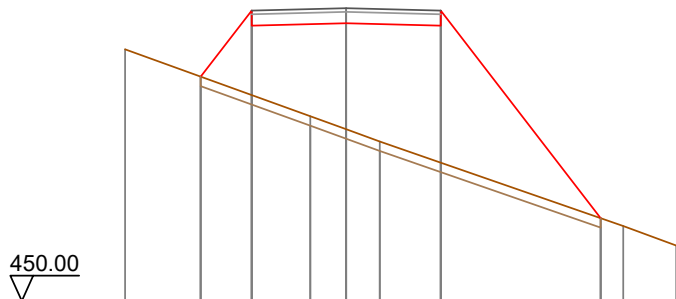

Quote Terreno	-456.65		-454.89	-454.54	-454.22		-451.98	-451.46
Quote Progetto		455.93	457.28	457.34	457.28		452.19	
Parziali		1.35	2.50	2.50	4.23			
Progressiva		-3.85	-2.50	0.00	2.50		6.73	
Dislivelli		-0.00	2.23	2.80	3.62		0.00	

Sezione: 24
 Progressiva: 220.000
 Q. Progetto: 460.702

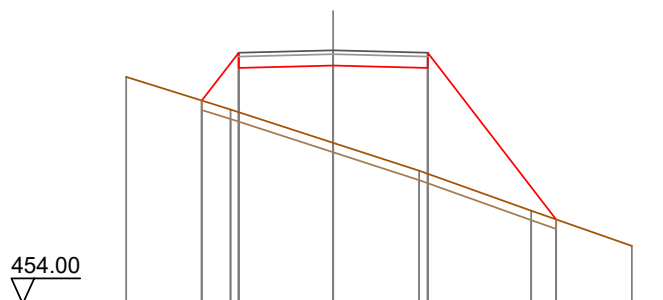

Quote Terreno	-460.00	-459.13	-458.25	-457.52	-456.46	-455.53
Quote Progetto		459.37	460.24	460.30	460.24	456.23
Parziali		0.97	2.50	2.50	3.40	
Progressiva		-3.47	-2.50	0.00	2.50	5.90
Dislivelli		-0.00	1.57	2.05	2.80	-0.00

Sezione: 25
 Progressiva: 240.000
 Q. Progetto: 464.493

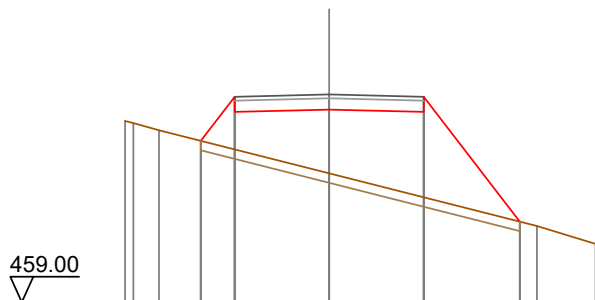

Quote Terreno	463.79	463.74	463.55		462.41		461.01	460.54
Quote Progetto			463.27	464.03	464.09	464.03	461.13	
Parziali			0.90	2.50	2.50	2.54		
Progressiva			-3.40	-2.50	0.00	2.50	5.04	
Dislivelli			-0.00	1.39	1.69	2.26	0.00	

Sezione: 26
 Progressiva: 260.000
 Q. Progetto: 468.652

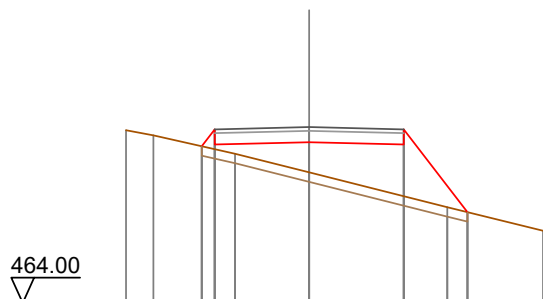

Quote Terreno	468.57	468.43	467.95	467.45	466.53	465.91
Quote Progetto		468.14	468.19	468.25	468.19	466.40
Parziali		0.34	2.50	2.50	1.69	
Progressiva		-2.84	-2.50	0.00	2.50	4.19
Dislivelli		0.00	0.52	0.80	1.37	0.00

Sezione: 27
 Progressiva: 264.105
 Q. Progetto: 469.506

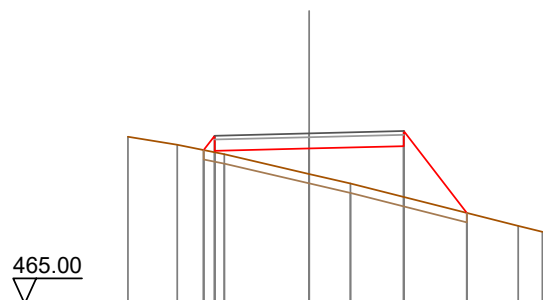

Quote Terreno	469.42	469.21	468.95	468.43	468.18	467.06	466.90
Quote Progetto		469.06	469.04	469.11	469.17	467.40	
Parziali		0.23	2.50	2.50	1.67		
Progressiva		-2.79	-2.50	0.00	2.50	4.17	
Dislivelli		0.00	0.44	0.67	1.35	-0.00	

Sezione: 28
 Progressiva: 270.000
 Q. Progetto: 470.732

467.00

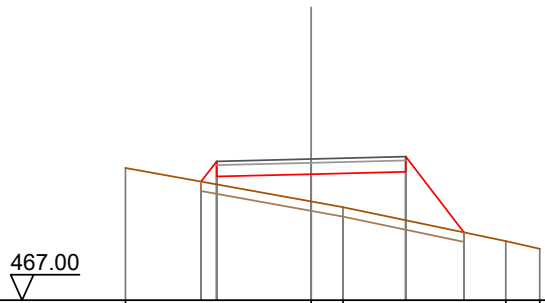

Quote Terreno	-470.50		469.61		-468.56	-468.36
Quote Progetto		470.13 470.27	470.33		470.39	468.79
Parziali		0.41	2.50		2.50	1.54
Progressiva		-2.91 -2.50	0.00		2.50	4.04
Dislivelli		0.00 0.61	0.72		1.28	0.00

Sezione: 29
 Progressiva: 280.000
 Q. Progetto: 472.812

469.00

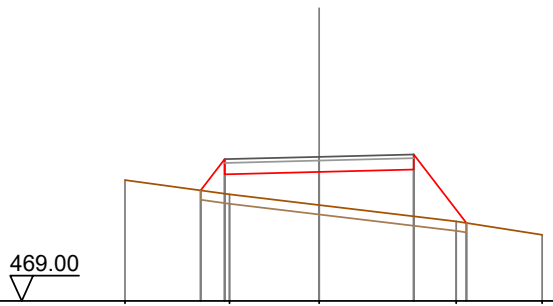

Quote Terreno	-472.20		471.54		471.10	-470.75
Quote Progetto		471.92 472.35	472.41		472.47	471.06
Parziali		0.64	2.50		2.50	1.40
Progressiva		-3.14 -2.50	0.00		2.50	3.90
Dislivelli		-0.00 0.91	0.87		1.24	0.00

Sezione: 30
 Progressiva: 290.000
 Q. Progetto: 474.892

471.00

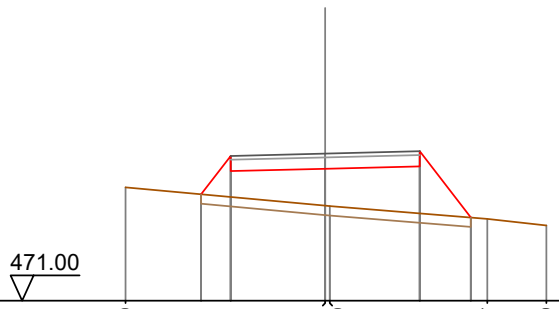

Quote Terreno	-474.00		473.51 473.50		473.17	-472.99
Quote Progetto		473.81 474.43	474.48		474.55	473.20
Parziali		0.78	2.50		2.50	1.35
Progressiva		-3.28 -2.50	0.00		2.50	3.85
Dislivelli		0.00 1.09	0.98		1.24	0.00

Sezione: 31
 Progressiva: 300.000
 Q. Progetto: 476.971

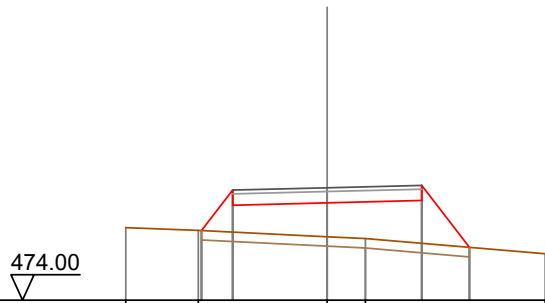

Quote Terreno	-475.92	-475.84	-475.88	-475.63	-475.22	
Quote Progetto		475.84	476.51	476.63	475.39	
Parziali		0.82	2.50	2.50	1.26	
Progressiva		-3.32	-2.50	0.00	2.50	3.76
Dislivelli		0.00	1.11	0.90	1.13	0.00

Sezione: 32
 Progressiva: 307.577
 Q. Progetto: 478.547

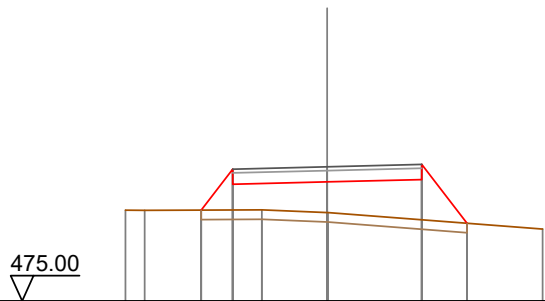

Quote Terreno	-477.40	-477.40	-477.41	-477.34	-476.90	
Quote Progetto		477.40	478.08	478.15	478.21	477.05
Parziali		0.83	2.50	2.50	1.20	
Progressiva		-3.33	-2.50	0.00	2.50	3.70
Dislivelli		0.00	1.08	0.81	1.06	0.00

Sezione: 33
 Progressiva: 310.000
 Q. Progetto: 479.051

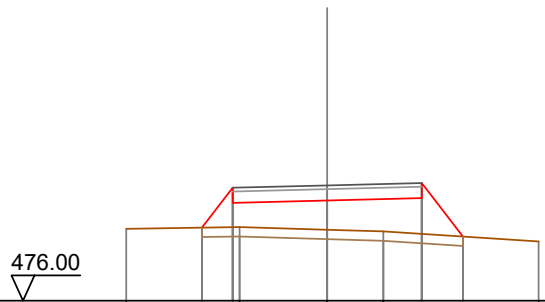

Quote Terreno	-477.90	-477.93	-477.88	-477.83	-477.57	
Quote Progetto		477.93	478.65	478.71	477.70	
Parziali		0.81	2.50	2.50	1.09	
Progressiva		-3.31	-2.50	0.00	2.50	3.59
Dislivelli		0.00	1.04	0.77	0.95	0.00

Sezione: 34
 Progressiva: 320.000
 Q. Progetto: 481.131

478.00

Quote Terreno	479.94	480.09	480.09	480.18	480.28	480.21
Quote Progetto		480.09	480.67	480.73	480.79	480.27
Parziali		0.75	2.50	2.50	0.71	
Progressiva		-3.25	-2.50	0.00	2.50	3.21
Dislivelli		0.00	0.95	0.55	0.54	0.00

Sezione: 35
 Progressiva: 330.000
 Q. Progetto: 483.211

481.00

Quote Terreno	482.10	482.43	482.61	482.70	482.97	482.98
Quote Progetto		482.38	482.75	482.81	482.87	482.83
Parziali		0.59	2.50	2.50	0.34	
Progressiva		-3.09	-2.50	0.00	2.50	2.84
Dislivelli		0.00	0.70	0.20	0.07	0.00

Sezione: 36
 Progressiva: 340.000
 Q. Progetto: 485.291

483.00

Quote Terreno	484.21	484.40	484.89	485.01	485.68	
Quote Progetto		484.56	484.83	484.89	484.95	485.38
Parziali		0.52	2.50	2.50		
Progressiva		-3.02	-2.50	0.00	2.50	2.52
Dislivelli		0.00	0.60	-0.12	-0.43	0.00

Sezione: 37
 Progressiva: 350.000
 Q. Progetto: 487.353

485.00

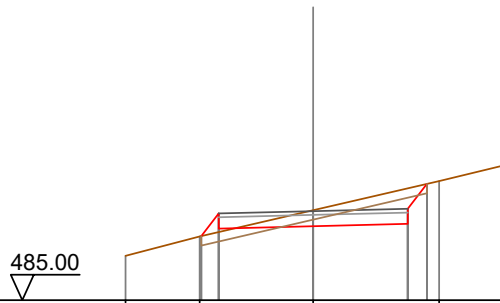

Quote Terreno	-486.17	-486.68	-487.38	-488.15	-488.55
Quote Progetto		486.69 486.89	486.95	487.02 488.07	
Parziali		0.46 2.50	2.50	0.51	
Progressiva		-2.96 -2.50	0.00	2.50 3.01	
Dislivelli		-0.00 0.49	-0.43	-0.94 0.00	

Sezione: 38
 Progressiva: 351.049
 Q. Progetto: 487.560

485.00

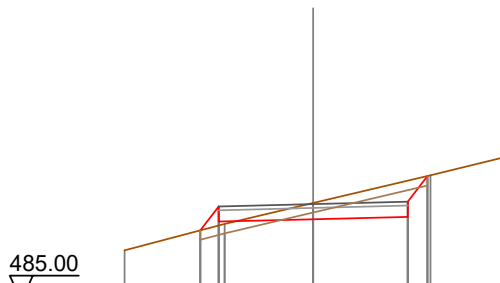

Quote Terreno	-486.34	-487.04	-487.59	-488.32	-488.79
Quote Progetto		486.87 487.10	487.16	487.22 488.30	
Parziali		0.49 2.50	2.50	0.52	
Progressiva		-2.99 -2.50	0.00	2.50 3.02	
Dislivelli		-0.00 0.50	-0.43	-0.96 0.00	

Sezione: 39
 Progressiva: 360.000
 Q. Progetto: 489.205

486.00

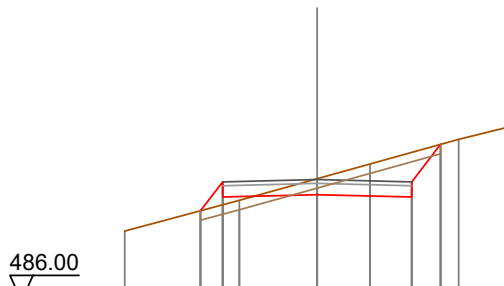

Quote Terreno	-487.84	-488.66	-489.23	-489.61	-490.27	-490.64
Quote Progetto		488.38 488.74	488.81	488.74 490.14		
Parziali		0.59 2.50	2.50	0.76		
Progressiva		-3.09 -2.50	0.00	2.50 3.26		
Dislivelli		-0.00 0.60	-0.42	-1.18 -0.00		

Sezione: 40
 Progressiva: 365.581
 Q. Progetto: 490.125

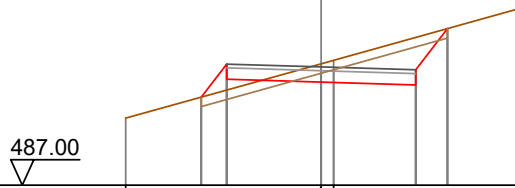

Quote Terreno	-488.77			490.21	490.30			-491.70
Quote Progetto		489.33	489.80	489.73		489.65	491.14	
Parziali		0.67	2.50	2.50		0.84		
Progressiva		-3.17	-2.50	0.00		2.50	3.34	
Dislivelli		-0.00	0.69	-0.48		-1.25	0.00	

Sezione: 41
 Progressiva: 370.000
 Q. Progetto: 490.796

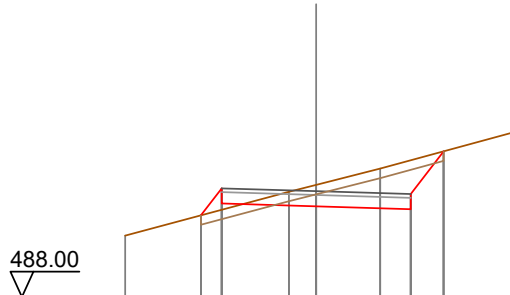

Quote Terreno	-489.62			490.78	490.96			-492.40
Quote Progetto		490.16	490.47	490.40		490.32	491.85	
Parziali		0.55	2.50	2.50		0.87		
Progressiva		-3.05	-2.50	0.00		2.50	3.37	
Dislivelli		0.00	0.57	-0.57		-1.29	-0.00	

Sezione: 42
 Progressiva: 377.320
 Q. Progetto: 491.797

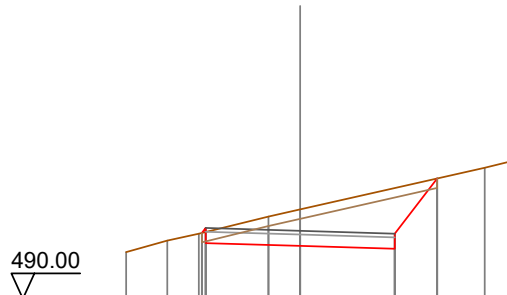

Quote Terreno	-491.23	-491.54	-491.72	-492.17	-492.36			-493.46	-493.65
Quote Progetto		491.74	491.47		491.40		491.32	493.18	
Parziali				2.50	2.50		1.12		
Progressiva		-2.60	-2.50	0.00			2.50	3.62	
Dislivelli		-0.00	0.11	-0.96			-1.60	-0.00	

Sezione: 43
 Progressiva: 377.677
 Q. Progetto: 491.842

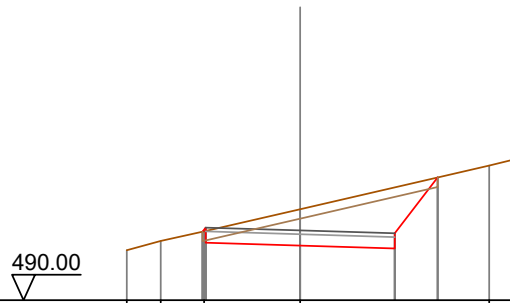

Quote Terreno	-491.32	-491.56	-491.82	-492.40	-493.56	-493.71
Quote Progetto			-491.81 -491.52	-491.44	-491.37	-493.24
Parziali			2.50	2.50	1.14	
Progressiva		-2.58 -2.50		0.00	2.50	3.64
Dislivelli		0.00 0.09		-0.96	-1.61	-0.00

SEZIONI TRASVERSALI

Profilo longitudinale tratto 11-16

Viabilità di impianto-Postazione aerogeneratore VI06

Nota: Le canalette di deflusso delle acque meteoriche, non indicate nel presente elaborato, sono rappresentate graficamente nelle sezioni stradali tipo dell'elaborato "SR-VI-TC12_Piazzole aerogeneratori e strade di servizio - Particolari costruttivi", individuate planimetricamente nell'elaborato "SR-VI-TC13_Opere di regimazione acque superficiali - Planimetria generale" e quantificate nell'elaborato "SR-VI-RC6_Computo Metrico Estimativo opere civili".

DISEGNI DI RIFERIMENTO

TAVOLA	DESCRIZIONE
SR-VI-TC8.1	Piazzole e viabilità - Planimetria di progetto - Fase di cantiere
SR-VI-TC10	Profili longitudinali viabilità di impianto
SR-VI-TC12	Piazzole aerogeneratori e strade di servizio - Particolari costruttivi
SR-VI-TC13	Opere di regimazione acque superficiali - Planimetria generale

Sezione: 1
 Progressiva: 0.000
 Q. Progetto: 377.913

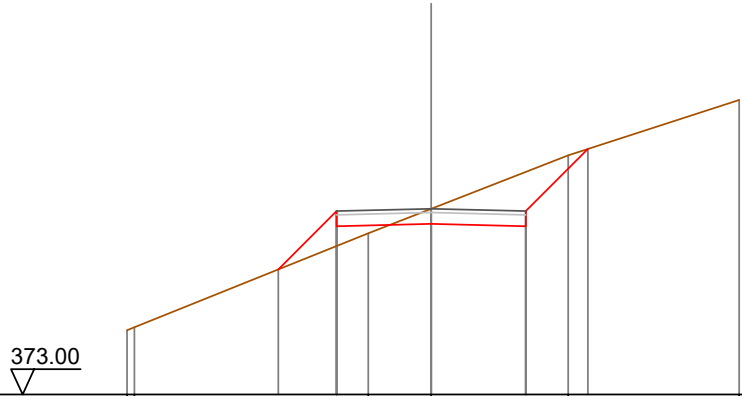

Quote Terreno	374.70							380.79
	374.78							
Quote Progetto		376.31	377.45	377.51	377.45	379.50		
Parziali		1.54	2.50	2.50	1.65			
Progressiva		-4.04	-2.50	0.00	2.50	4.15		
Dislivelli		0.00	0.92	-0.40	-1.44	-0.00		

Sezione: 2
 Progressiva: 14.227
 Q. Progetto: 378.021

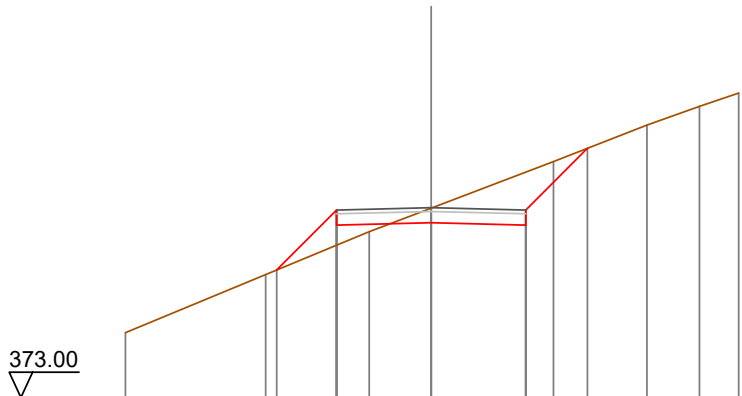

Quote Terreno	374.71							381.05
	376.25							
Quote Progetto		376.37	377.56	377.62	377.56	379.59		
Parziali		1.59	2.50	2.50	1.63			
Progressiva		-4.09	-2.50	0.00	2.50	4.13		
Dislivelli		0.00	0.93	-0.39	-1.40	0.00		

Sezione: 3
 Progressiva: 20.000
 Q. Progetto: 378.160

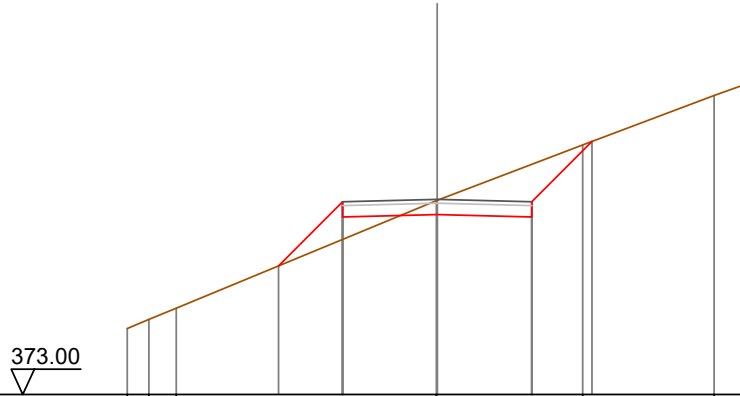

Quote Terreno	-374.75	-374.99	-375.28				378.13			379.60		380.91	-381.18
Quote Progetto				376.40	377.70	377.76	378.13	377.70	379.69				
Parziali					1.70	2.50	2.50	1.59					
Progressiva				-4.20	-2.50	0.00	2.50	4.09					
Dislivelli				-0.00	1.00	-0.37	-1.39	0.00					

Sezione: 4
 Progressiva: 38.105
 Q. Progetto: 378.666

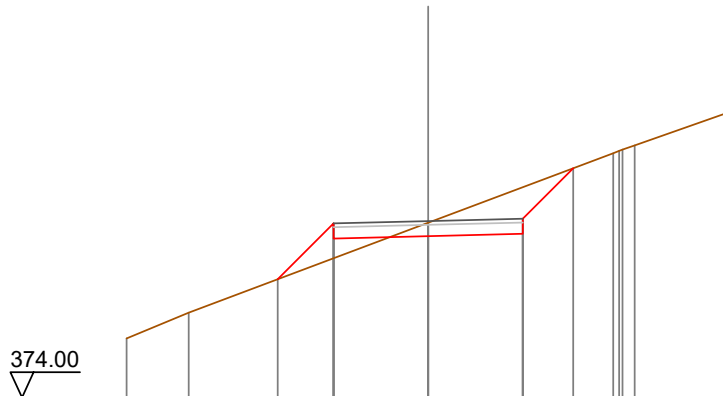

Quote Terreno	-375.56	-376.24				378.62				380.46	-380.67	-381.50
Quote Progetto			377.13	378.20	378.27	378.62	378.33	380.06				
Parziali			1.48	2.50	2.50	1.33						
Progressiva			-3.98	-2.50	0.00	2.50	3.83					
Dislivelli			-0.00	0.92	-0.36	-1.23	-0.00					

Sezione: 5
 Progressiva: 39.405
 Q. Progetto: 378.703

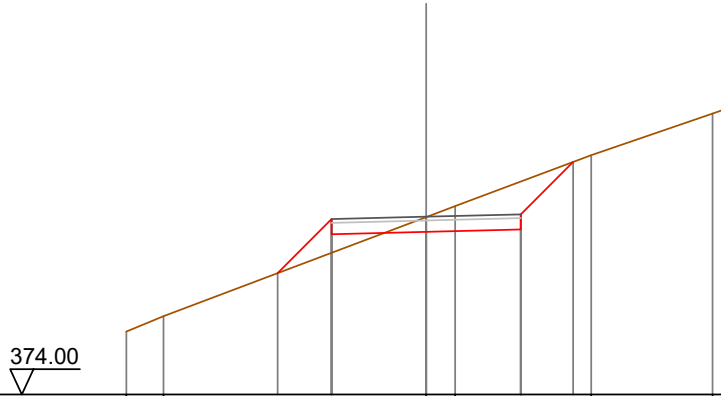

Quote Terreno	-375.66	-376.07				378.69	-378.98	-380.33	381.43	-381.54
Quote Progetto			377.21	378.24	378.30	378.37	380.15			
Parziali			1.43	2.50	2.50	1.39				
Progressiva			-3.93	-2.50	0.00	2.50	3.89			
Dislivelli			0.00	0.89	-0.39	-1.27	0.00			

Sezione: 6
 Progressiva: 40.000
 Q. Progetto: 378.719

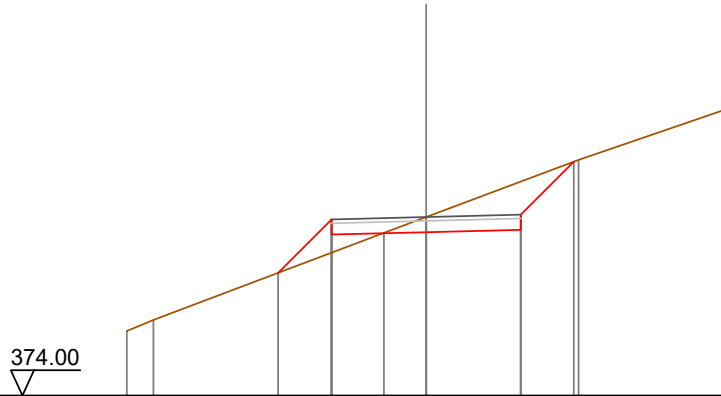

Quote Terreno	-375.70	-376.00			378.30	378.72	380.23	381.56	
Quote Progetto			377.24	378.26	378.32	378.38	380.18		
Parziali			1.41	2.50	2.50	1.40			
Progressiva			-3.91	-2.50	0.00	2.50	3.90		
Dislivelli			-0.00	0.88	-0.40	-1.28	0.00		

Sezione: 7
 Progressiva: 40.705
 Q. Progetto: 378.739

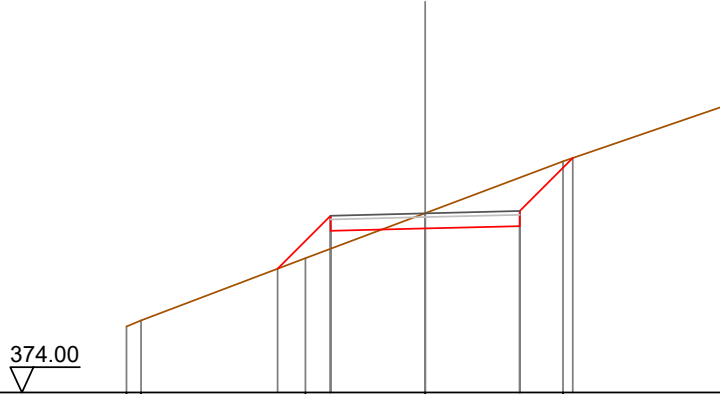

Quote Terreno		-375.75	-375.91		-377.55		-378.74		-380.12		-381.58
Quote Progetto				377.28	378.28	378.34	378.74	378.40	380.20		
Parziali				1.40	2.50	2.50	1.40				
Progressiva				-3.90	-2.50	0.00	2.50	3.90			
Dislivelli				0.00	0.87	-0.41	-1.28	0.00			

Sezione: 8
 Progressiva: 49.360
 Q. Progetto: 378.962

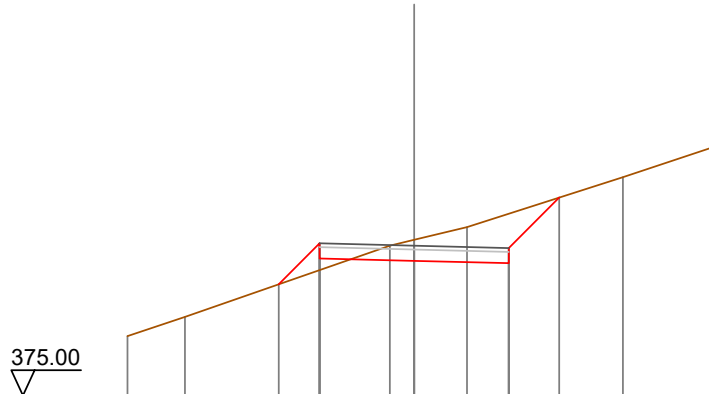

Quote Terreno		-376.57	-377.08		-378.96	-379.12	-379.45		-380.77		-381.55
Quote Progetto				377.94	378.62	378.56	378.50	380.24			
Parziali				1.08	2.50	2.50	1.34				
Progressiva				-3.58	-2.50	0.00	2.50	3.84			
Dislivelli				0.00	0.71	-0.56	-1.31	0.00			

Sezione: 9
 Progressiva: 50.000
 Q. Progetto: 378.973

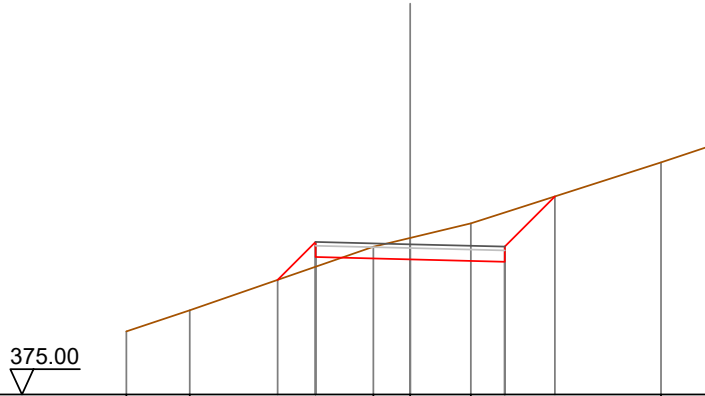

Quote Terreno	-376.67	-377.23		-378.91	-379.14	-379.53		-381.14	-381.54
Quote Progetto			378.03	378.64	378.57	378.51	380.24		
Parziali			1.00	2.50	2.50	1.33			
Progressiva			-3.50	-2.50	0.00	2.50	3.83		
Dislivelli			0.00	0.66	-0.57	-1.30	-0.00		

Sezione: 10
 Progressiva: 60.000
 Q. Progetto: 379.052

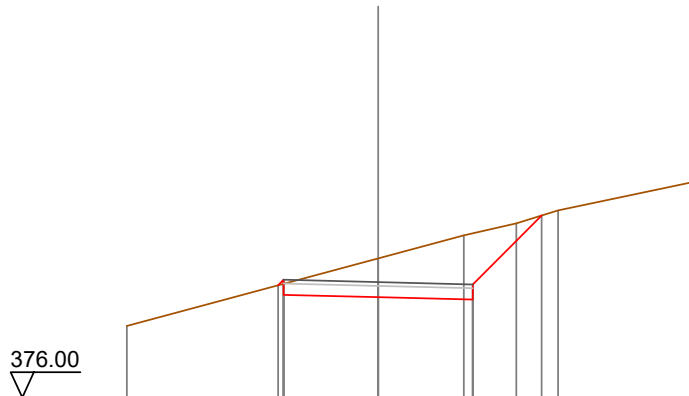

Quote Terreno	-377.89			-379.68	-380.29	-380.60	-380.95		-381.70
Quote Progetto			378.97	378.71	378.65	378.59	380.81		
Parziali				2.50	2.50	1.82			
Progressiva			-2.65	-2.50	0.00	2.50	4.32		
Dislivelli			0.00	0.11	-1.03	-1.75	-0.00		

Sezione: 11
 Progressiva: 62.858
 Q. Progetto: 379.038

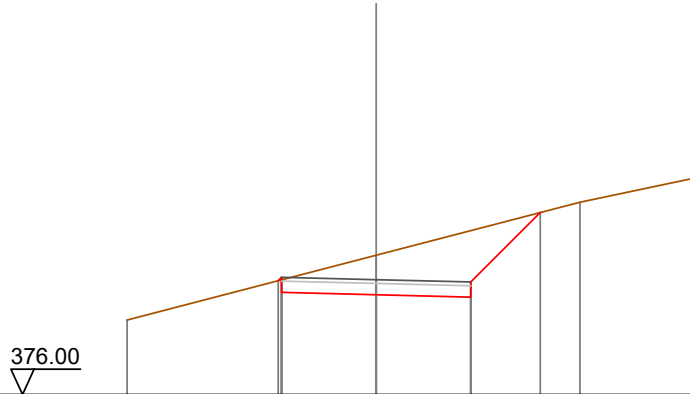

Quote Terreno	-377.97		379.01	379.68		381.09	381.71
Quote Progetto		378.70	378.64	378.56	380.81		
Parziali		2.50	2.50	1.84			
Progressiva		-2.59	0.00	2.50	4.34		
Dislivelli		-0.00	-1.05	-1.76	-0.00		

Sezione: 12
 Progressiva: 70.000
 Q. Progetto: 378.931

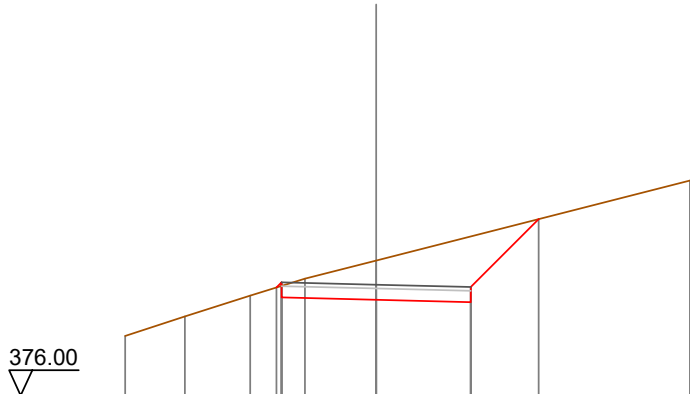

Quote Terreno	-377.57	-378.09	378.64	379.09	379.57		381.68
Quote Progetto			378.86	378.59	378.53	378.47	380.66
Parziali			2.50	2.50	1.80		
Progressiva			-2.64	0.00	2.50	4.30	
Dislivelli			0.00	-1.04	-1.74	0.00	

Sezione: 13
 Progressiva: 76.356
 Q. Progetto: 378.750

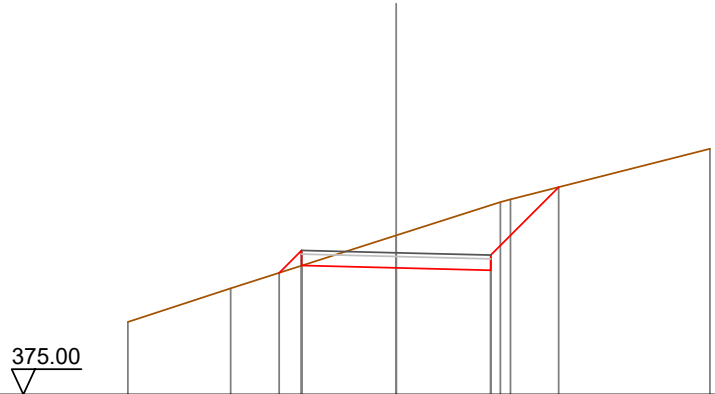

Quote Terreno	-376.92	-377.81			378.22	378.41		379.21		380.09	380.16		-381.50
Quote Progetto					378.22	378.41		378.35		378.29	380.48		
Parziali					0.60	2.50		2.50		1.80			
Progressiva					-3.10	-2.50		0.00		2.50	4.30		
Dislivelli					0.00	0.41		-0.86		-1.72	0.00		

Sezione: 14
 Progressiva: 80.000
 Q. Progetto: 378.609

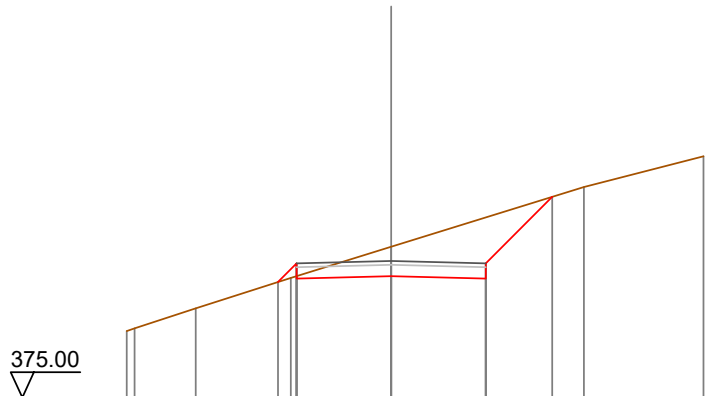

Quote Terreno	376.76	376.83	-377.36		378.16			378.99			380.57		-381.38
Quote Progetto					378.05	378.15		378.21		378.15	380.31		
Parziali					0.49	2.50		2.50		1.76			
Progressiva					-2.99	-2.50		0.00		2.50	4.26		
Dislivelli					-0.00	0.34		-0.78		-1.61	0.00		

Sezione: 15
 Progressiva: 96.257
 Q. Progetto: 377.659

374.00

Quote Terreno	-375.73		-377.58	-378.02		-379.09	-379.71	-380.25
Quote Progetto			377.06 377.20	377.26		377.32 379.19		
Parziali			0.53 2.50	2.50		1.47		
Progressiva			-3.03 -2.50	0.00		2.50 3.97		
Dislivelli			-0.00 0.36	-0.76		-1.43 -0.00		

Sezione: 16
 Progressiva: 99.635
 Q. Progetto: 377.401

374.00

Quote Terreno	-375.53	-375.78	-377.15	-377.75		-378.77	-379.20	-379.46	-379.82
Quote Progetto			376.84 376.94	377.00		377.06 378.88			
Parziali			0.49 2.50	2.50		1.41			
Progressiva			-2.99 -2.50	0.00		2.50 3.91			
Dislivelli			-0.00 0.33	-0.75		-1.41 0.00			

Sezione: 17
 Progressiva: 100.000
 Q. Progetto: 377.372

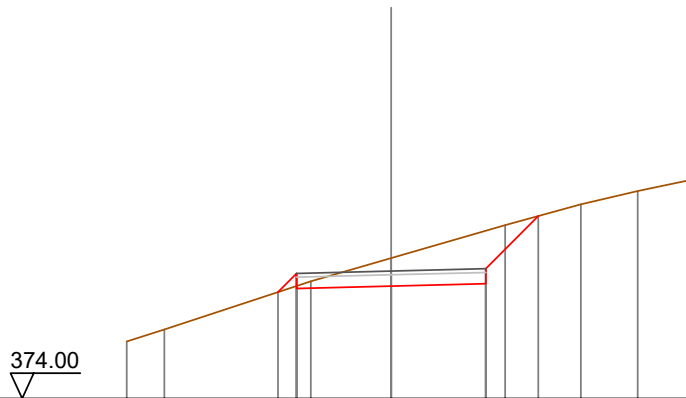

Quote Terreno	-375.51	-375.83	-377.10	-377.71	-378.59	-379.14	-379.49	-379.78
Quote Progetto			376.81 376.91	376.97	377.03	378.83		
Parziali			0.49 2.50	2.50	1.39			
Progressiva			-2.99 -2.50	0.00	2.50	3.89		
Dislivelli			0.00 0.33	-0.74	-1.40	0.00		

Sezione: 18
 Progressiva: 103.014
 Q. Progetto: 377.121

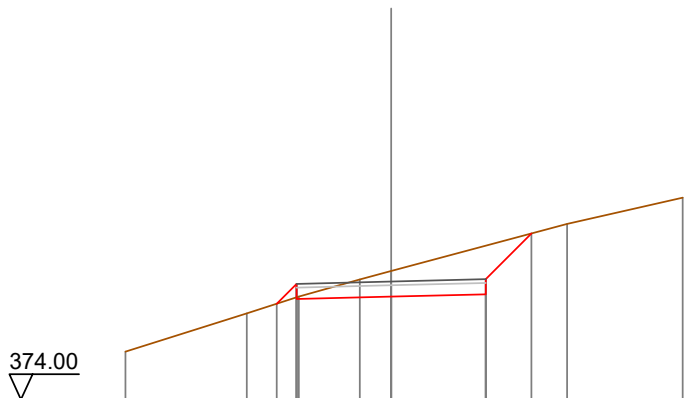

Quote Terreno	-375.26	-376.28	-376.72	-377.18	-377.40	-378.64	-379.34
Quote Progetto			376.53 376.66	376.72	376.78	378.39	
Parziali			0.53 2.50	2.50	1.21		
Progressiva			-3.03 -2.50	0.00	2.50	3.71	
Dislivelli			0.00 0.36	-0.68	-1.28	-0.00	

Sezione: 19
 Progressiva: 120.000
 Q. Progetto: 375.361

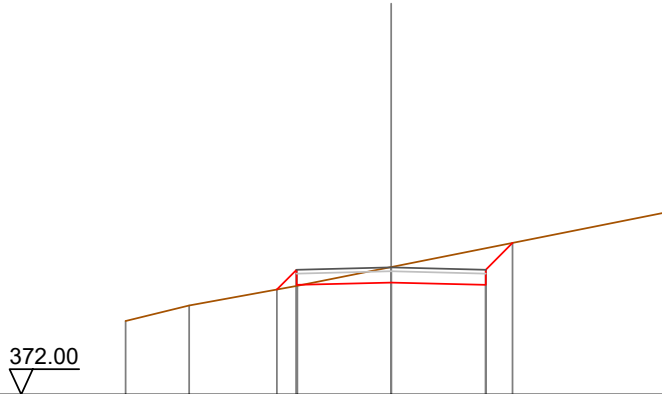

Quote Terreno		-373.95	-374.36	-374.88	-375.37		-376.81
Quote Progetto				374.78 374.90	374.96	374.90 376.01	
Parziali				0.52 2.50	2.50	0.71	
Progressiva				-3.02 -2.50	0.00	2.50 3.21	
Dislivelli				0.00 0.43	-0.41	-0.97 -0.00	

Sezione: 20
 Progressiva: 140.000
 Q. Progetto: 373.364

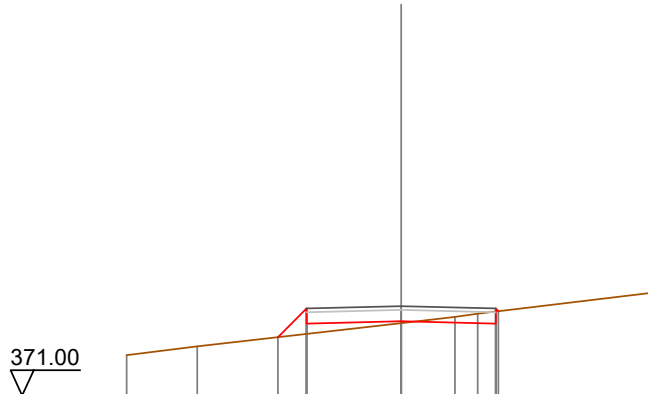

Quote Terreno		-372.07	-372.30	-372.54	-372.90	-372.96	-372.91	-373.08	-373.16	-373.23	-373.71
Quote Progetto				372.54 372.90	372.96	372.96	372.90 373.23				
Parziali				0.76 2.50	2.50						
Progressiva				-3.26 -2.50	0.00	2.50 2.57					
Dislivelli				-0.00 0.67	0.05	-0.32 0.00					

Sezione: 21
 Progressiva: 160.000
 Q. Progetto: 372.171

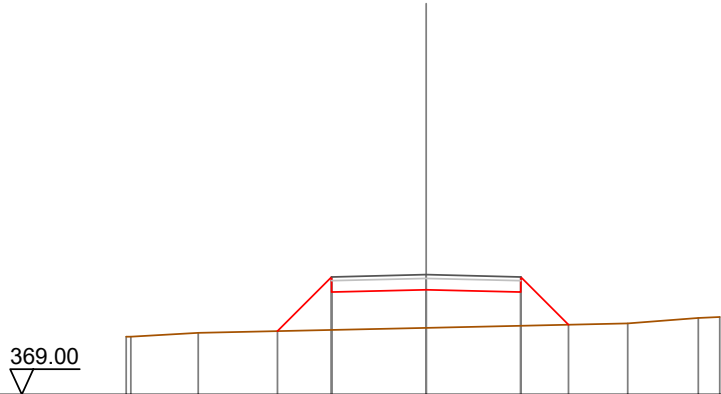

Quote Terreno	370.53	370.53	370.63			370.68	371.71	370.76	371.71	370.85	370.88	371.02	371.05
Quote Progetto						370.68	371.71	371.77	371.71	370.85			
Parziali						1.43	2.50	2.50	1.26				
Progressiva						-3.93	-2.50	0.00	2.50	3.76			
Dislivelli						0.00	1.40	1.01	0.89	0.00			

Sezione: 22
 Progressiva: 162.296
 Q. Progetto: 372.076

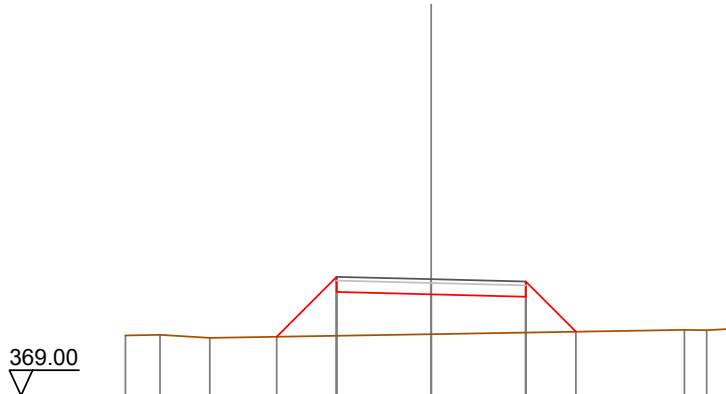

Quote Terreno	370.59	370.60	370.53			370.56	371.74	370.62	371.61	370.69		370.73	370.73	370.76
Quote Progetto						370.56	371.74	371.68	371.61	370.69				
Parziali						1.58	2.50	2.50	1.33					
Progressiva						-4.08	-2.50	0.00	2.50	3.83				
Dislivelli						0.00	1.56	1.05	0.95	0.00				

Sezione: 23
 Progressiva: 163.891
 Q. Progetto: 372.010

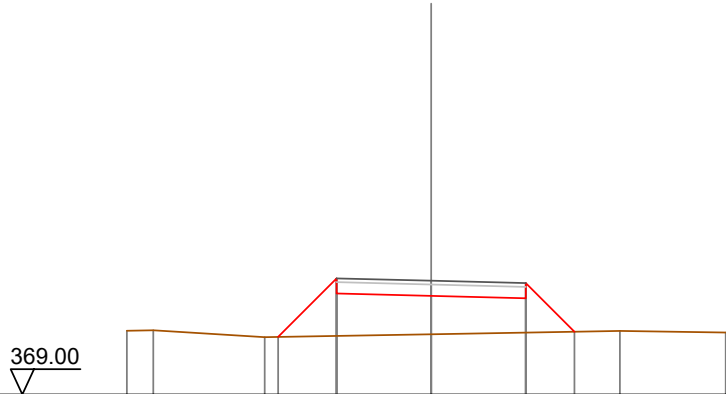

Quote Terreno	-370.69	-370.70	-370.52	-370.59	-370.68	-370.64
Quote Progetto			370.52	371.61	371.55	370.66
Parziali			1.55	2.50	2.50	1.29
Progressiva			-4.05	-2.50	0.00	2.50
Dislivelli			0.00	1.52	1.02	0.91

Sezione: 24
 Progressiva: 165.485
 Q. Progetto: 371.944

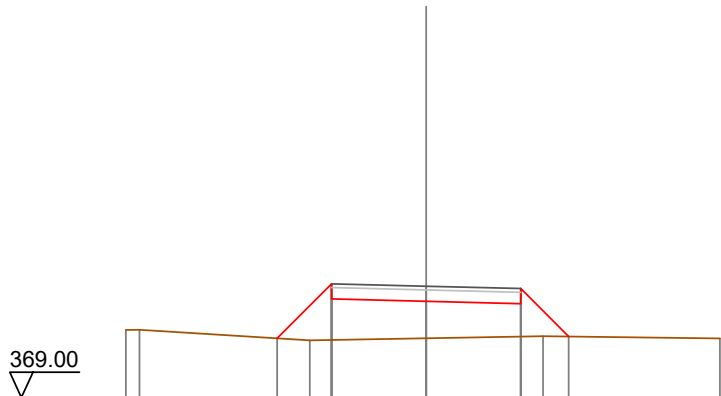

Quote Terreno	-370.79	-370.79	-370.51	-370.56	-370.62	-370.56
Quote Progetto			370.56	371.61	371.54	371.48
Parziali			1.44	2.50	2.50	1.27
Progressiva			-3.94	-2.50	0.00	2.50
Dislivelli			-0.00	1.49	0.98	0.87

Sezione: 25
 Progressiva: 180.000
 Q. Progetto: 371.569

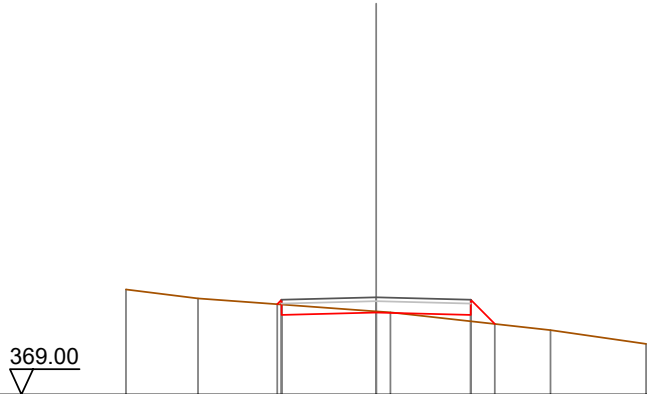

Quote Terreno	-371.78	-371.54	371.39	371.11	371.20	371.17	371.11	370.87	-370.70	-370.34
Quote Progetto			371.39	371.11	371.17	371.17	371.11	370.87		
Parziali			2.50	2.50	0.64					
Progressiva			-2.62	-2.50	0.00	0.00	2.50	3.14		
Dislivelli			0.00	0.13	-0.03	-0.03	0.17	0.00		

Sezione: 26
 Progressiva: 200.000
 Q. Progetto: 371.728

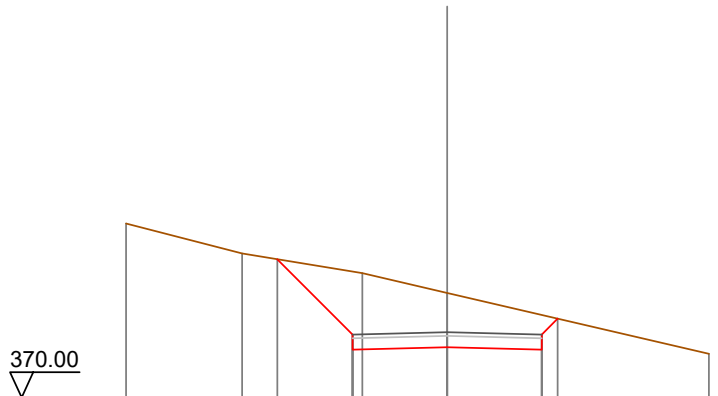

Quote Terreno	-374.60	-373.81	-373.66	-373.29	-372.77	-371.27	-372.09	-371.16
Quote Progetto		373.66	371.27	371.33	372.77	371.27	372.09	
Parziali		1.99	2.50	2.50	0.42			
Progressiva		-4.49	-2.50	0.00	0.00	2.50	2.92	
Dislivelli		0.00	-1.66	-1.44	-1.44	-0.92	-0.00	

Sezione: 27
 Progressiva: 205.878
 Q. Progetto: 371.798

370.00

Quote Terreno	-374.51	-373.98		-373.09	-372.94	-372.55	-371.31
Quote Progetto			373.86	371.46	371.40	371.34	372.32
Parziali			1.80	2.50	2.50	0.58	
Progressiva			-4.30	-2.50	0.00	2.50	3.08
Dislivelli			0.00	-1.50	-1.54	-1.12	-0.00

Sezione: 28
 Progressiva: 210.000
 Q. Progetto: 371.806

370.00

Quote Terreno	-374.20	-374.12	-374.09	-374.00		-372.83	-371.97	-371.40	
Quote Progetto					373.59	371.47	371.41	371.34	372.29
Parziali					1.72	2.50	2.50	0.54	
Progressiva					-4.22	-2.50	0.00	2.50	3.04
Dislivelli					-0.00	-1.41	-1.43	-1.04	-0.00

Sezione: 29
 Progressiva: 211.193
 Q. Progetto: 371.802

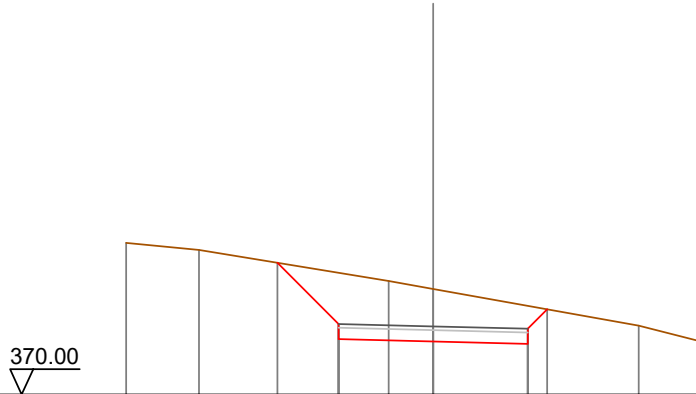

Quote Terreno	-374.01	-373.82		-373.00	-372.79		-371.82	-371.42
Quote Progetto			373.48	371.46	371.40	371.34	372.25	
Parziali			1.62	2.50	2.50	0.51		
Progressiva			-4.12	-2.50	0.00	2.50	3.01	
Dislivelli			0.00	-1.35	-1.39	-1.00	0.00	

Sezione: 30
 Progressiva: 216.507
 Q. Progetto: 371.750

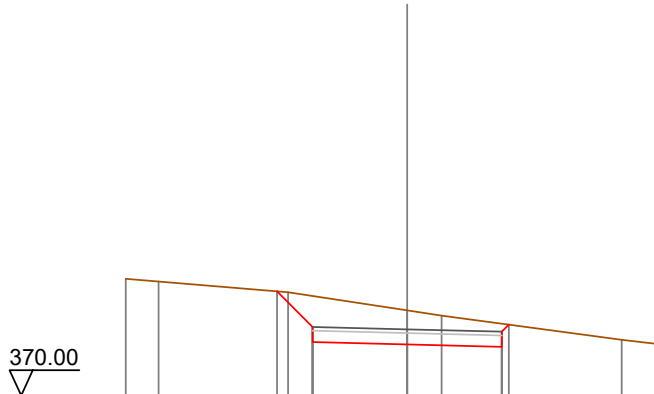

Quote Terreno	-373.09	-373.01		-372.73	-372.25	-372.11		-371.47	-371.36
Quote Progetto				372.76	371.41	371.35	371.29	371.87	
Parziali				0.94	2.50	2.50			
Progressiva				-3.44	-2.50	0.00	2.50	2.68	
Dislivelli				-0.00	-0.82	-0.90	-0.61	-0.00	

Sezione: 31
 Progressiva: 220.000
 Q. Progetto: 371.685

370.00

Quote Terreno	-372.55	-372.51		-372.19	-371.98		-371.39	-371.14
Quote Progetto			372.29	371.22	371.28	371.22		
Parziali			0.67	2.50	2.50			
Progressiva			-3.17	-2.50	0.00	2.50		
Dislivelli			-0.00	-0.62	-0.69	-0.42		

Sezione: 32
 Progressiva: 230.906
 Q. Progetto: 371.324

369.00

Quote Terreno	-371.32	-371.31		-371.03	-370.88		-370.49
Quote Progetto			371.15	370.92	370.86	370.90	
Parziali			2.50	2.50	0.36		
Progressiva			-2.74	-2.50	0.00	2.50	2.86
Dislivelli			0.00	0.25	-0.10	-0.06	0.00

Sezione: 33
 Progressiva: 235.375
 Q. Progetto: 371.107

369.00

Quote Terreno	-370.92	-370.89			370.80	370.77		370.70	370.60	370.51	370.31
Quote Progetto					370.80	370.77		370.71	370.64	370.59	
Parziali					0.37	2.50		2.50	0.45		
Progressiva					-2.87	-2.50		0.00	2.50	2.95	
Dislivelli					-0.00	0.38		0.01	0.04	0.00	

Sezione: 34
 Progressiva: 239.845
 Q. Progetto: 370.854

369.00

Quote Terreno	-370.50	-370.47	-370.46					370.40			-370.30	-370.24
Quote Progetto								370.45	370.39	370.35		
Parziali								0.47	2.50	2.50	0.44	
Progressiva								-2.97	-2.50	0.00	2.50	2.94
Dislivelli								0.00	0.47	0.05	0.03	0.00

Sezione: 35
 Progressiva: 255.569
 Q. Progetto: 370.194

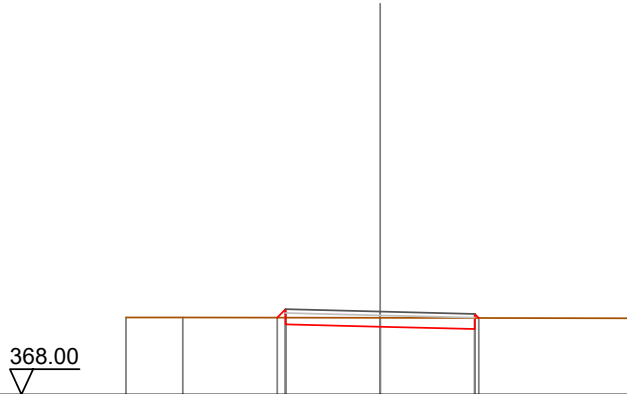

Quote Terreno	-370.04	-370.04		370.03	370.03				-370.02
Quote Progetto			370.03	369.86	369.79	369.73	370.02		
Parziali			2.50	2.50					
Progressiva			-2.72	-2.50	0.00	2.50	2.61		
Dislivelli			0.00	0.22	-0.24	-0.29	-0.00		

Sezione: 36
 Progressiva: 260.000
 Q. Progetto: 370.097

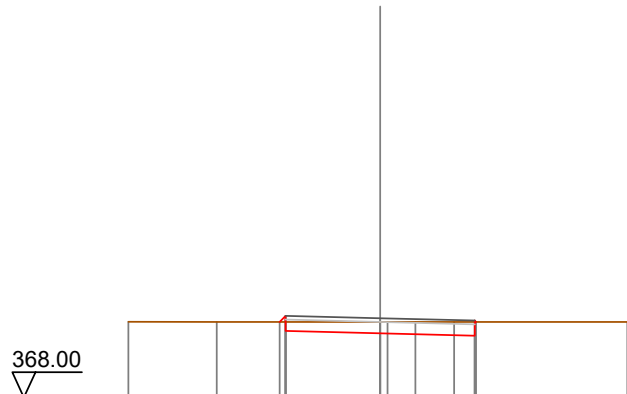

Quote Terreno	-370.00	-370.00		370.00	370.00				-370.00
Quote Progetto			370.00	369.76	369.70	369.63	370.00		
Parziali			2.50	2.50					
Progressiva			-2.66	-2.50	0.00	2.50	2.53		
Dislivelli			-0.00	0.16	-0.30	-0.37	-0.00		

Sezione: 37
 Progressiva: 265.002
 Q. Progetto: 370.035

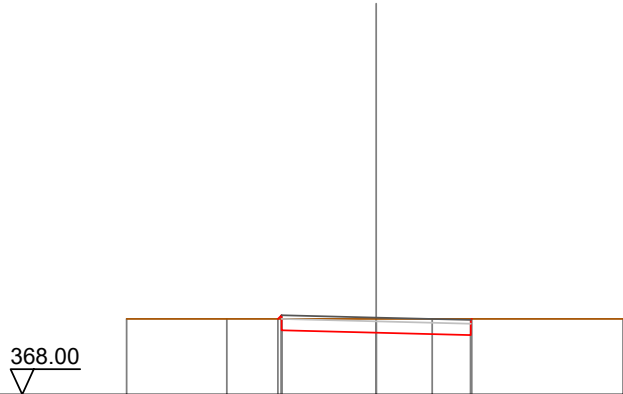

Quote Terreno		370.00	370.00	370.00	370.00	370.00
Quote Progetto			370.00	369.70	369.64	370.00
Parziali			2.50	2.50		
Progressiva			-2.60	-2.50	0.00	2.50
Dislivelli			-0.00	0.10	-0.36	-0.43

Sezione: 38
 Progressiva: 270.000
 Q. Progetto: 370.020

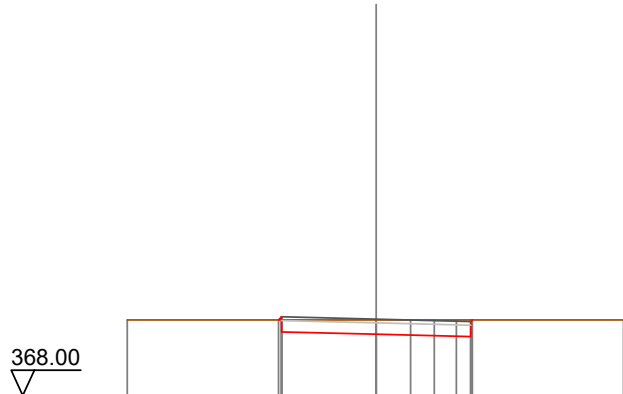

Quote Terreno		370.00	370.00	370.00	370.00	370.00
Quote Progetto			370.00	369.68	369.62	370.00
Parziali			2.50	2.50		
Progressiva			-2.58	-2.50	0.00	2.50
Dislivelli			-0.00	0.08	-0.38	-0.44

Sezione: 39
 Progressiva: 274.435
 Q. Progetto: 370.015

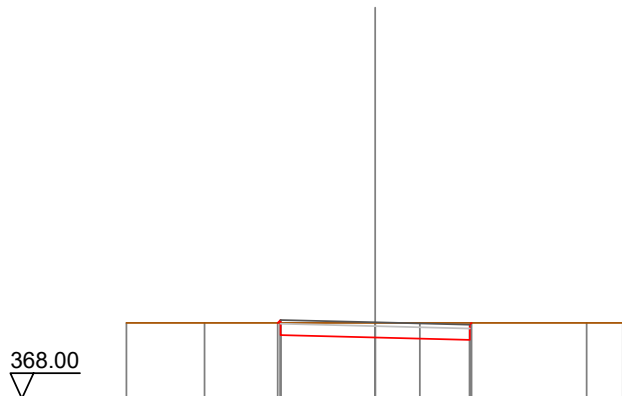

Quote Terreno	-370.00	-370.00	370.00	370.00	-370.00	-370.00
Quote Progetto			370.00 369.68	369.61	369.55 370.00	
Parziali			2.50	2.50		
Progressiva			-2.58 -2.50	0.00	2.50 2.55	
Dislivelli			-0.00 0.08	-0.39	-0.45 0.00	

Sezione: 40
 Progressiva: 280.000
 Q. Progetto: 370.009

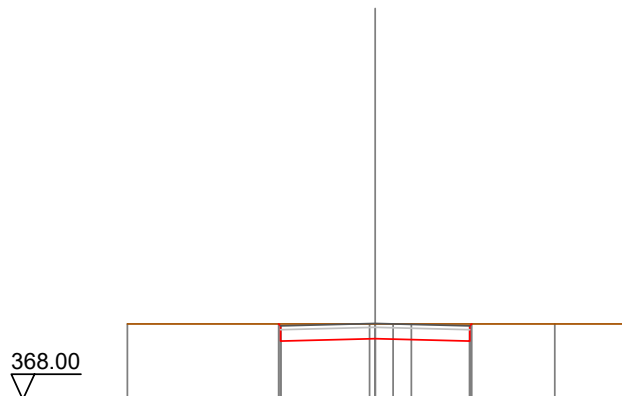

Quote Terreno	-370.00	-370.00	370.00	370.00	-370.00	-370.00
Quote Progetto			370.00 369.55	369.61	369.55 370.00	
Parziali			2.50	2.50		
Progressiva			-2.55 -2.50	0.00	2.50 2.55	
Dislivelli			0.00 -0.05	-0.39	-0.45 0.00	

Sezione: 41
 Progressiva: 297.891
 Q. Progetto: 369.989

368.00

Quote Terreno	-370.00	-370.00	-369.98	-369.91	-369.91
Quote Progetto		370.00 369.53	369.59	369.65 369.95	
Parziali		2.50	2.50		
Progressiva		-2.57 -2.50	0.00	2.50 2.60	
Dislivelli		0.00 -0.07	-0.39	-0.30 0.00	

Sezione: 42
 Progressiva: 300.000
 Q. Progetto: 369.986

368.00

Quote Terreno	-370.00	-370.00	-369.96	-369.92	-369.90
Quote Progetto		370.00 369.52	369.59	369.65 369.94	
Parziali		2.50	2.50		
Progressiva		-2.58 -2.50	0.00	2.50 2.61	
Dislivelli		0.00 -0.08	-0.37	-0.29 0.00	

Sezione: 43
 Progressiva: 305.418
 Q. Progetto: 369.980

368.00

Quote Terreno	-370.00	-370.00	-370.00	-369.89	-369.70	-369.67
Quote Progetto		370.00	369.52	369.58	369.64	369.75
Parziali			2.50	2.50	0.28	
Progressiva		-2.58	-2.50	0.00	2.50	2.79
Dislivelli		0.00	-0.08	-0.31	-0.12	0.00

Sezione: 44
 Progressiva: 310.000
 Q. Progetto: 369.975

368.00

Quote Terreno	-370.00	-370.00	-370.00	-370.00	-369.91	-369.57
Quote Progetto			370.00	369.51	369.58	369.64
Parziali				2.50	2.50	0.27
Progressiva			-2.59	-2.50	0.00	2.50
Dislivelli			-0.00	-0.09	-0.33	-0.15
						0.00

Sezione: 45
 Progressiva: 312.944
 Q. Progetto: 369.972

368.00

Quote Terreno	-370.01	-370.01	-370.00	-369.93	-369.70	-369.36
Quote Progetto			370.00 369.51	369.57	369.63 369.79	
Parziali			2.50	2.50		
Progressiva			-2.59 -2.50	0.00	2.50 2.74	
Dislivelli			0.00 -0.09	-0.35	-0.17 -0.00	

Sezione: 46
 Progressiva: 320.000
 Q. Progetto: 369.906

367.00

Quote Terreno	-370.02	-370.00	-370.00	-369.98	-369.94	-368.91
Quote Progetto			370.00 369.44	369.51	369.44	369.52
Parziali			2.50	2.50	0.33	
Progressiva			-2.66 -2.50	0.00	2.50 2.83	
Dislivelli			0.00 -0.16	-0.44	-0.12 0.00	

Sezione: 47
 Progressiva: 332.293
 Q. Progetto: 369.563

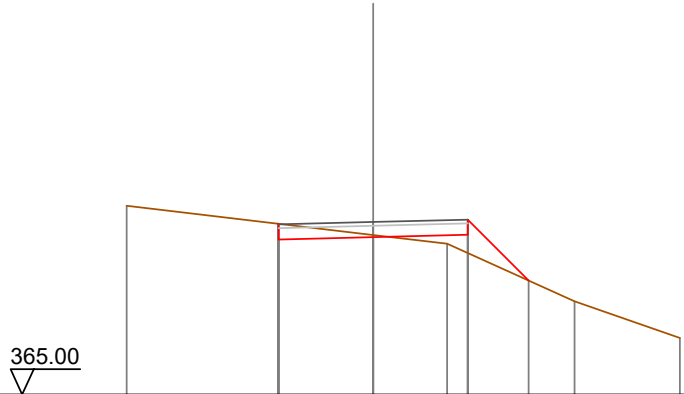

Quote Terreno		369.99		369.22		368.99		367.47		366.50
Quote Progetto			369.10		369.16		369.23		368.01	
Parziali				2.50		2.50		1.61		
Progressiva			-2.52		0.00		2.50		4.11	
Dislivelli			0.00		-0.06		0.48		-0.00	

Sezione: 48
 Progressiva: 332.567
 Q. Progetto: 369.554

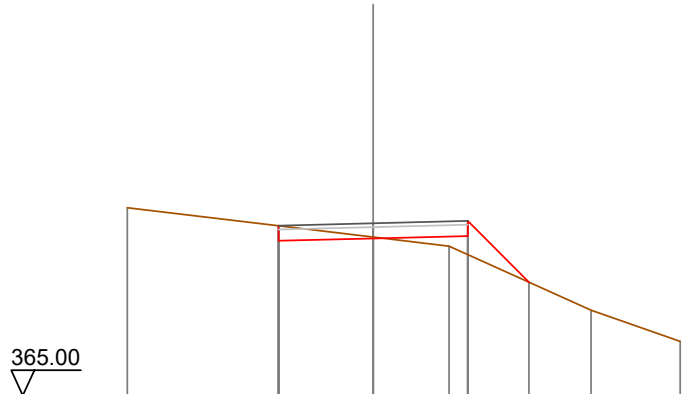

Quote Terreno		369.97		369.19		368.95		367.25		366.43
Quote Progetto			369.09		369.15		369.22		368.00	
Parziali				2.50		2.50		1.62		
Progressiva			-2.50		0.00		2.50		4.12	
Dislivelli			0.00		-0.04		0.49		-0.00	

Sezione: 49
 Progressiva: 332.841
 Q. Progetto: 369.545

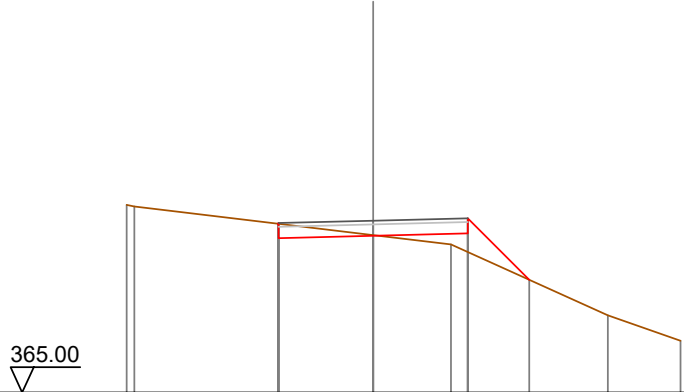

Quote Terreno		369.96 369.92		369.16	368.92		367.04	366.37
Quote Progetto			369.08	369.15	369.21	367.98		
Parziali			2.50	2.50	1.63			
Progressiva			-2.52	0.00	2.50	4.13		
Dislivelli			0.00	-0.02	0.49	0.00		

Sezione: 50
 Progressiva: 340.000
 Q. Progetto: 369.376

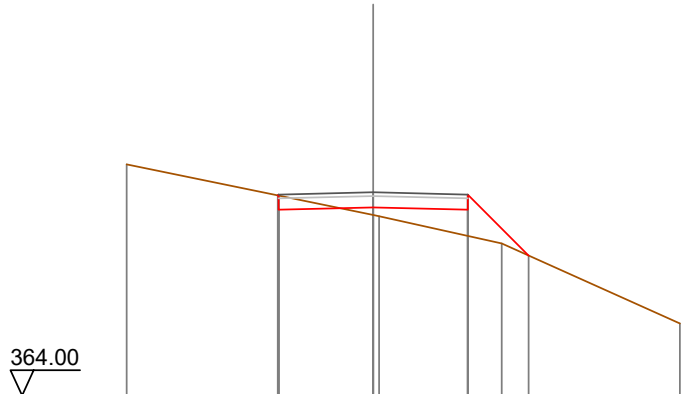

Quote Terreno		370.11		368.77 368.74	368.02		365.90
Quote Progetto			369.29 368.91	368.98	368.91	367.70	
Parziali			2.50	2.50	1.61		
Progressiva			-2.52 -2.50	0.00	2.50	4.11	
Dislivelli			0.00 0.03	0.20	0.69	-0.00	

Sezione: 51
 Progressiva: 341.859
 Q. Progetto: 369.348

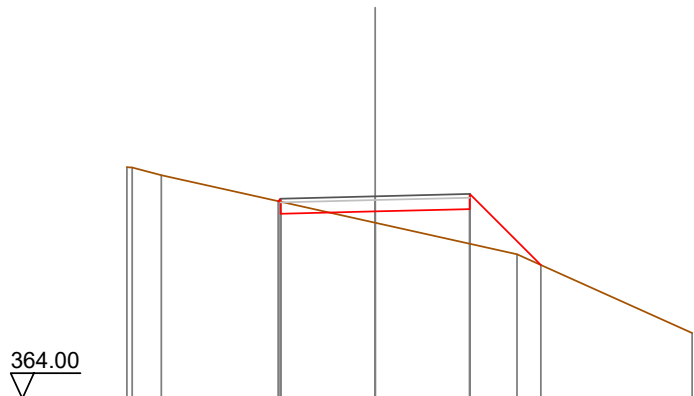

Quote Terreno	370.12	370.11	369.91		368.65		367.81		365.73
Quote Progetto				369.22	368.89	368.95	369.01	367.53	
Parziali					2.50	2.50	1.88		
Progressiva				-2.57	-2.50	0.00	2.50	4.38	
Dislivelli				0.00	0.08	0.30	0.92	0.00	

Sezione: 52
 Progressiva: 350.000
 Q. Progetto: 369.310

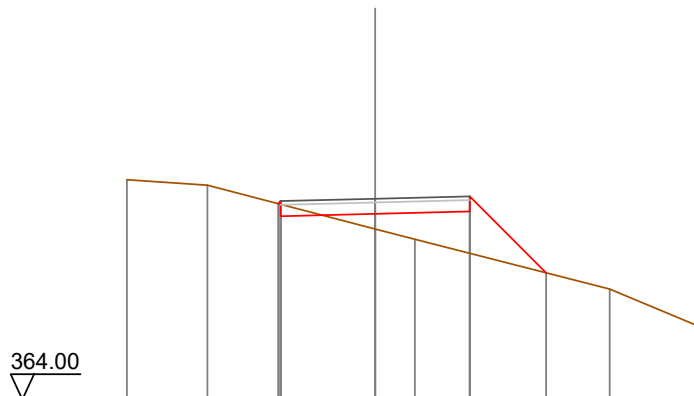

Quote Terreno	369.81	369.67		368.51	368.24		367.35	366.92	365.95
Quote Progetto			369.18	368.85	368.91	368.97	367.35		
Parziali				2.50	2.50	2.02			
Progressiva			-2.57	-2.50	0.00	2.50	4.52		
Dislivelli			0.00	0.08	0.40	1.11	0.00		

Sezione: 53
 Progressiva: 360.000
 Q. Progetto: 369.442

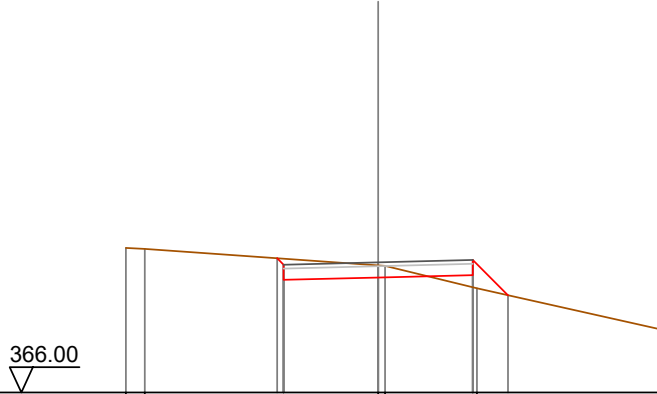

Quote Terreno		-369.82	-369.80			369.36	369.35		368.76		-367.68
Quote Progetto				369.55	368.98		369.04		369.10	368.57	
Parziali						2.50		2.50		0.93	
Progressiva				-2.67	-2.50		0.00		2.50	3.43	
Dislivelli				0.00	-0.16		-0.32		0.32	-0.00	

Sezione: 54
 Progressiva: 361.691
 Q. Progetto: 369.473

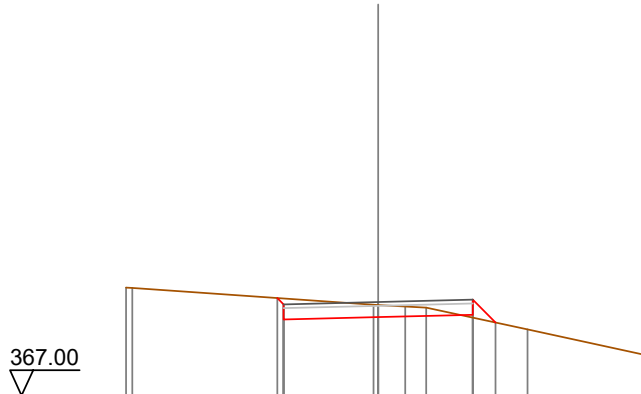

Quote Terreno		-369.85	-369.85			-369.40	-369.39	-369.35	-369.33		-368.75		-368.06
Quote Progetto				369.58	369.01		369.07		369.14	368.83			
Parziali						2.50		2.50		0.60			
Progressiva				-2.67	-2.50		0.00		2.50	3.10			
Dislivelli				0.00	-0.16		-0.32		0.07	-0.00			

Sezione: 55
 Progressiva: 370.000
 Q. Progetto: 369.539

368.00

Quote Terreno	-369.91	-370.00	-369.76	-369.74	-369.54	-369.47
Quote Progetto			369.89 369.08	369.14	369.20 369.64	
Parziali			0.41 2.50	2.50		
Progressiva			-2.91 -2.50	0.00	2.50 2.54	
Dislivelli			-0.00 -0.39	-0.60	-0.44 -0.00	

Sezione: 56
 Progressiva: 380.000
 Q. Progetto: 369.436

367.00

Quote Terreno	-369.54	-369.67	-369.80	-370.00	-369.98
Quote Progetto			369.71 368.97	369.04	369.10 369.89
Parziali			0.33 2.50	2.50	0.39
Progressiva			-2.83 -2.50	0.00	2.50 2.89
Dislivelli			-0.00 -0.34	-0.76	-0.78 0.00

Sezione: 57
 Progressiva: 381.524
 Q. Progetto: 369.403

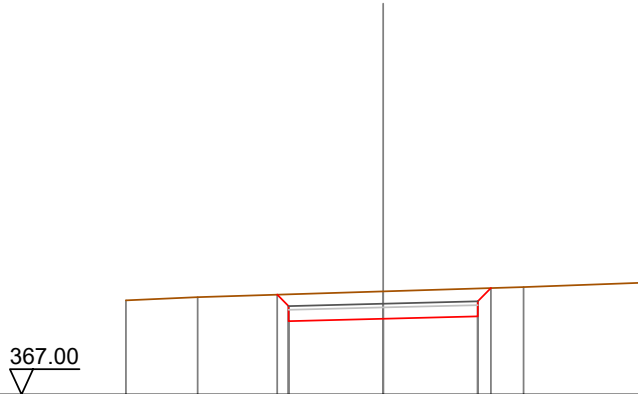

Quote Terreno	-369.49	-369.58			369.64	368.94	369.73		369.84	-369.96
Quote Progetto					369.64	368.94	369.00		369.07	369.82
Parziali					0.30	2.50	2.50		0.35	
Progressiva					-2.80	-2.50	0.00		2.50	2.85
Dislivelli					0.00	-0.31	-0.72		-0.74	-0.00

Sezione: 58
 Progressiva: 382.787
 Q. Progetto: 369.371

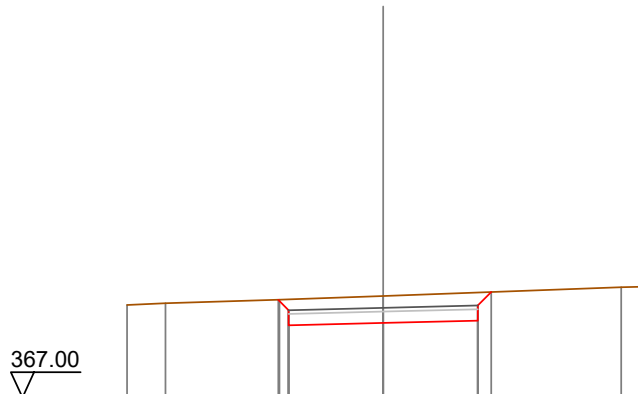

Quote Terreno	-369.45	-369.49			369.58	368.91	369.69		369.79	-369.92
Quote Progetto					369.58	368.91	368.97		369.03	369.79
Parziali					0.27	2.50	2.50		0.36	
Progressiva					-2.77	-2.50	0.00		2.50	2.86
Dislivelli					0.00	-0.28	-0.71		-0.74	0.00

Sezione: 59
 Progressiva: 390.000
 Q. Progetto: 369.133

367.00

Quote Terreno	-368.84	-369.25	-369.36	-369.53	-369.63	-369.74	-369.78
Quote Progetto		369.14 368.67	368.73	368.80 369.63			
Parziali		2.50	2.50	0.44			
Progressiva		-2.57 -2.50	0.00	2.50 2.94			
Dislivelli		0.00 -0.08	-0.63	-0.80 0.00			

Sezione: 60
 Progressiva: 399.051
 Q. Progetto: 368.685

367.00

Quote Terreno	-368.15	-368.46	-368.64	-368.73	-368.78	-368.98	-369.31
Quote Progetto		368.52 368.22	368.29	368.35 368.99			
Parziali		2.50	2.50				
Progressiva		-2.60 -2.50	0.00	2.50 2.74			
Dislivelli		0.00 0.09	-0.50	-0.62 0.00			

Sezione: 61
 Progressiva: 400.000
 Q. Progetto: 368.629

367.00

Quote Terreno	-368.06	-368.23	-368.55	-368.73	-368.74	-369.22	-369.24
Quote Progetto			368.46	368.17	368.23	368.29	368.94
Parziali				2.50	2.50		
Progressiva			-2.60	-2.50	0.00	2.50	2.75
Dislivelli			0.00	0.09	-0.51	-0.63	0.00

Sezione: 62
 Progressiva: 410.000
 Q. Progetto: 367.967

366.00

Quote Terreno	-367.39	-367.71	-367.99	-367.99	-368.47	-368.58	
Quote Progetto			367.76	367.50	367.63	368.22	
Parziali				2.50	2.50		
Progressiva			-2.64	-2.50	0.00	2.50	2.68
Dislivelli			0.00	0.13	-0.42	-0.57	0.00

Sezione: 63
 Progressiva: 415.314
 Q. Progetto: 367.650

366.00

Quote Terreno	-367.10	-367.40	-367.66	-368.30
Quote Progetto		367.45 367.19	367.25 367.66	367.31 367.92
Parziali		2.50	2.50	
Progressiva		-2.64 -2.50	0.00	2.50 2.71
Dislivelli		-0.00 0.13	-0.41	-0.59 0.00

Sezione: 64
 Progressiva: 420.000
 Q. Progetto: 367.405

365.00

Quote Terreno	-366.70	-366.99	-367.43	-367.94	-368.11
Quote Progetto			367.00 367.43	366.94 367.71	
Parziali			2.50	2.50	0.37
Progressiva		-2.67 -2.50	0.00	2.50 2.87	
Dislivelli		0.00 0.16	-0.42	-0.73 -0.00	

Sezione: 65
 Progressiva: 421.544
 Q. Progetto: 367.325

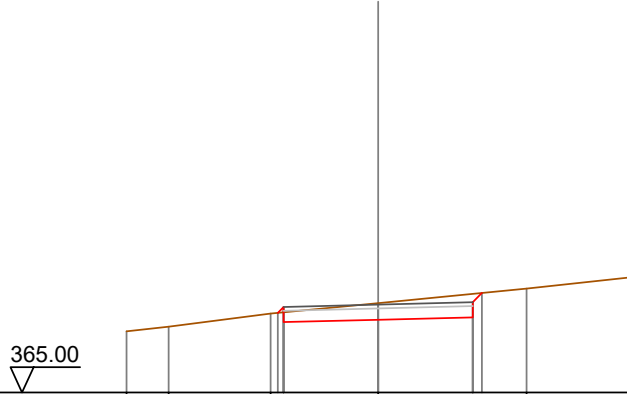

Quote Terreno	-366.62	-366.74	367.09	367.37	367.75	368.05
Quote Progetto			367.11	366.86	366.92	366.99
Parziali			2.50	2.50		
Progressiva			-2.66	0.00	2.50	2.75
Dislivelli			0.00	-0.44	-0.62	0.00

Sezione: 66
 Progressiva: 424.568
 Q. Progetto: 367.168

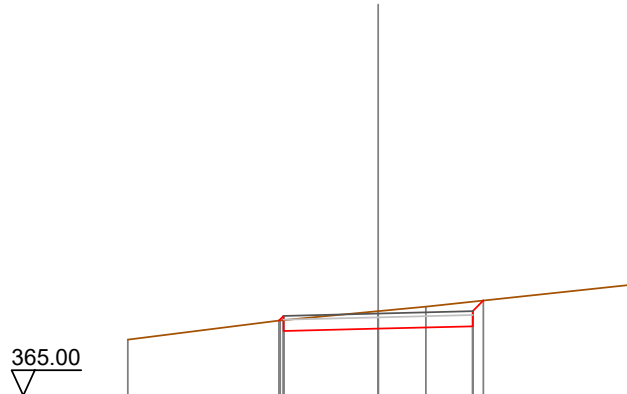

Quote Terreno	-366.48	366.99	367.23	367.35	367.94
Quote Progetto		366.98	366.71	366.77	366.83
Parziali		2.50	2.50	0.28	
Progressiva		-2.62	0.00	2.50	2.78
Dislivelli		0.00	-0.46	-0.65	0.00

Sezione: 67
 Progressiva: 427.592
 Q. Progetto: 367.011

365.00

Quote Terreno	-366.34	-366.88	-366.99	-367.09	-367.67	-367.81
Quote Progetto		366.83 366.55		366.61	366.67 367.39	
Parziali			2.50		2.50	0.31
Progressiva		-2.62 -2.50		0.00	2.50 2.81	
Dislivelli		0.00 0.11		-0.48	-0.68 0.00	

Sezione: 68
 Progressiva: 440.000
 Q. Progetto: 366.367

364.00

Quote Terreno	-365.85	-366.64	-366.78	-366.80	-367.67	
Quote Progetto		366.41 365.90		365.97	365.90 367.19	
Parziali			2.50		2.50	0.89
Progressiva		-2.61 -2.50		0.00	2.50 3.39	
Dislivelli		0.00 -0.12		-0.82	-1.18 0.00	

Sezione: 69
 Progressiva: 460.000
 Q. Progetto: 365.329

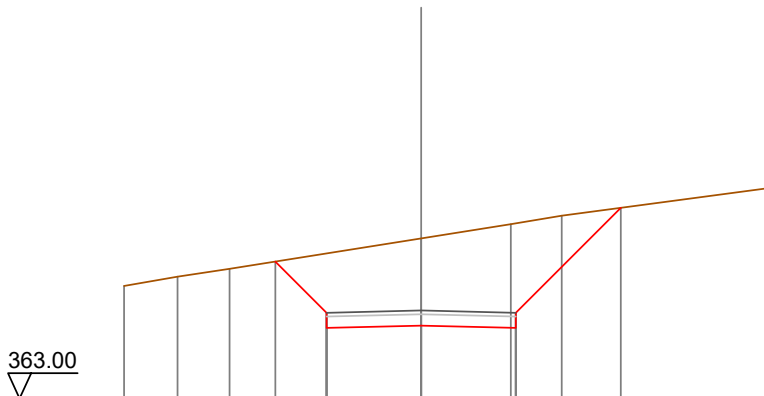

Quote Terreno	-365.98	-366.22	-366.43			366.62	364.87	364.83	367.23	367.61	-367.84		-368.57
Quote Progetto						366.62	364.87	364.83	367.23	364.87		368.04	
Parziali						1.36	2.50	2.50		2.78			
Progressiva						-3.86	-2.50	0.00		2.50		5.28	
Dislivelli						0.00	-1.57	-2.30		-2.77		0.00	

Sezione: 70
 Progressiva: 460.356
 Q. Progetto: 365.311

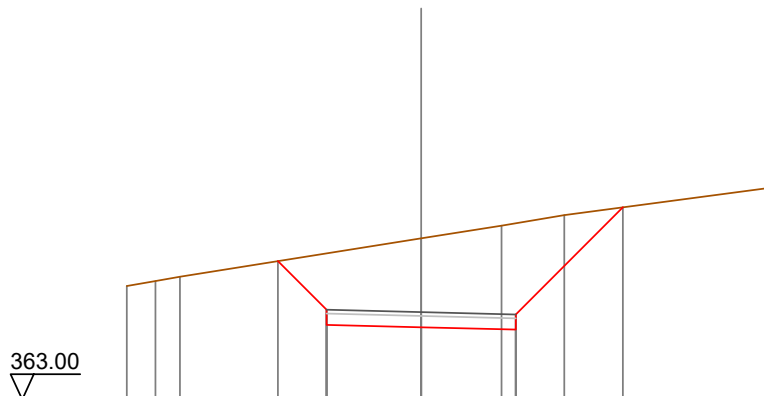

Quote Terreno	-366.00	-366.13	-366.25					367.26	367.60	-367.88			-368.61
Quote Progetto						366.66	364.97	364.91	367.26	364.85		368.08	
Parziali						1.29	2.50	2.50		2.83			
Progressiva						-3.79	-2.50	0.00		2.50		5.33	
Dislivelli						0.00	-1.49	-2.35		-2.81		0.00	

Sezione: 71
 Progressiva: 463.988
 Q. Progetto: 365.122

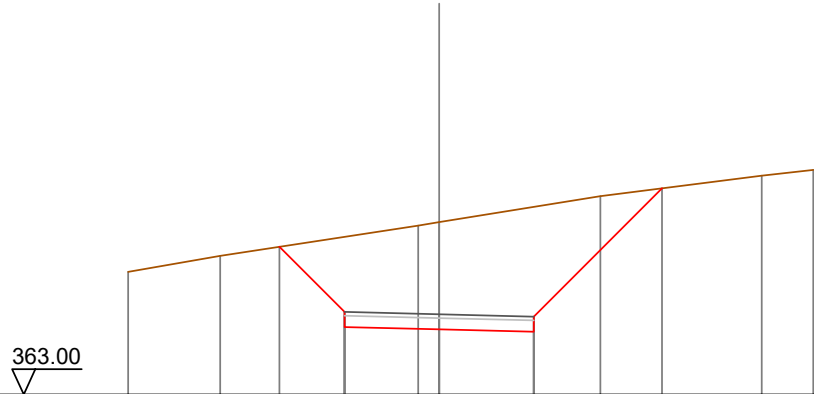

Quote Terreno	-366.24	-366.67	-366.91	-364.78	-367.47	-367.56	-368.25	-368.79	-368.94
Quote Progetto			366.91	364.78	364.72	364.66	368.45		
Parziali			1.72	2.50	2.50	3.39			
Progressiva			-4.22	-2.50	0.00	2.50	5.89		
Dislivelli			0.00	-1.99	-2.84	-3.30	0.00		

Sezione: 72
 Progressiva: 467.620
 Q. Progetto: 364.934

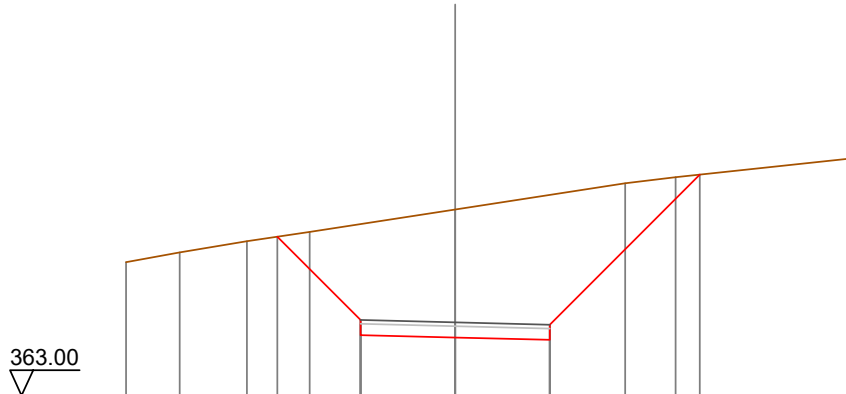

Quote Terreno	-366.52	-366.78	-367.08	-367.32	-367.92	-368.61	-368.77	-369.27
Quote Progetto			367.20	364.60	364.53	364.47	368.84	
Parziali			2.20	2.50	2.50	3.97		
Progressiva			-4.70	-2.50	0.00	2.50	6.47	
Dislivelli			0.00	-2.54	-3.39	-3.83	0.00	

Sezione: 73
 Progressiva: 478.123
 Q. Progetto: 364.419

362.00

Quote Terreno	-367.33	-368.15	-368.38	-368.57	-364.08	-369.10	-369.75	-370.35
Quote Progetto		368.19			364.08	364.02	363.96	370.02
Parziali			3.71		2.50	2.50	5.66	
Progressiva		-6.21		-2.50	0.00	2.50		8.16
Dislivelli		0.00		-4.28	-5.08	-5.47		0.00

Sezione: 74
 Progressiva: 480.000
 Q. Progetto: 364.345

362.00

Quote Terreno	-367.47	-368.42	-368.60	-364.01	-369.27	-369.79	-369.88	-370.47
Quote Progetto		368.33		364.01	363.95	363.88		370.15
Parziali			3.92		2.50	2.50	5.87	
Progressiva		-6.42		-2.50	0.00	2.50		8.37
Dislivelli		0.00		-4.53	-5.32	-5.71		0.00

Sezione: 75
 Progressiva: 482.405
 Q. Progetto: 364.262

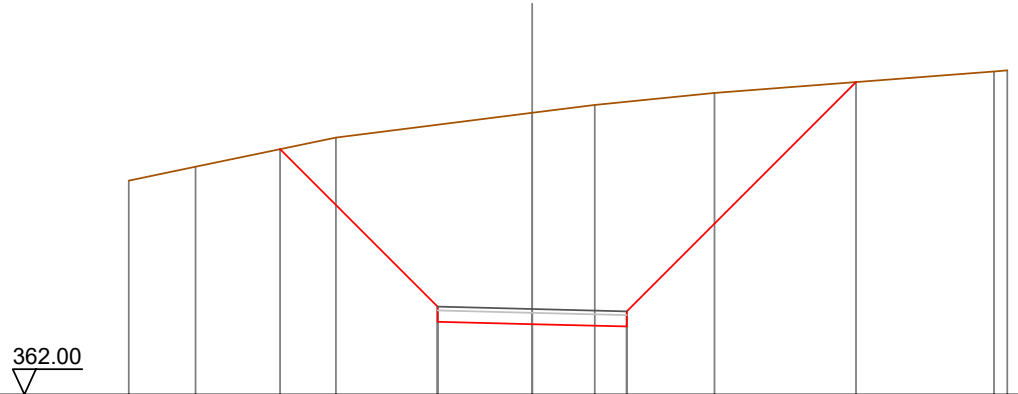

Quote Terreno	-367.66	-368.02	-368.80	-369.45	-369.66	-369.98	-370.55	-370.57
Quote Progetto			368.49	363.92	363.86	363.80	370.26	
Parziali			4.17	2.50	2.50	6.07		
Progressiva			-6.67	-2.50	0.00	2.50	8.57	
Dislivelli			-0.00	-4.81	-5.59	-5.95	0.00	

Sezione: 76
 Progressiva: 486.687
 Q. Progetto: 364.141

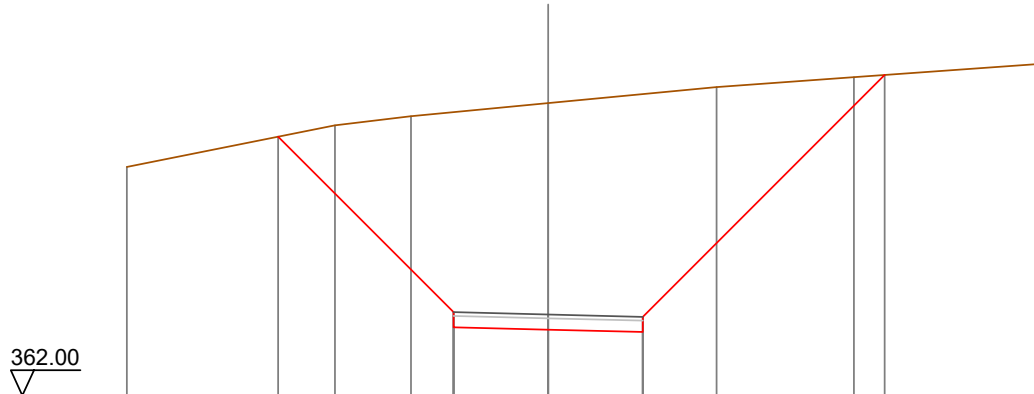

Quote Terreno	-368.05	-368.85	-369.15	-369.39	-369.73	-370.16	-370.42	-370.76
Quote Progetto		368.85		363.80	363.74	363.68	370.48	
Parziali		4.64		2.50	2.50	6.40		
Progressiva		-7.14		-2.50	0.00	2.50	8.90	
Dislivelli		-0.00		-5.29	-5.99	-6.29	-0.00	

Sezione: 77
 Progressiva: 491.510
 Q. Progetto: 364.050

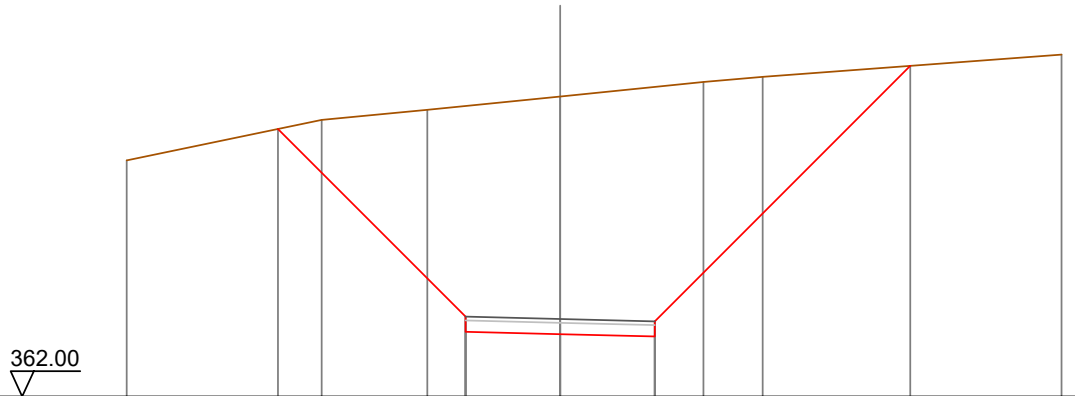

Quote Terreno	-368.24	-369.32	-369.58	-363.71	-369.94	-370.32	-370.45	-371.04
Quote Progetto		369.08		363.71	363.65	363.59		370.75
Parziali			4.96	2.50	2.50		6.76	
Progressiva		-7.46		-2.50	0.00	2.50		9.26
Dislivelli		0.00		-5.57	-6.29	-6.60		0.00

Sezione: 78
 Progressiva: 500.000
 Q. Progetto: 364.000

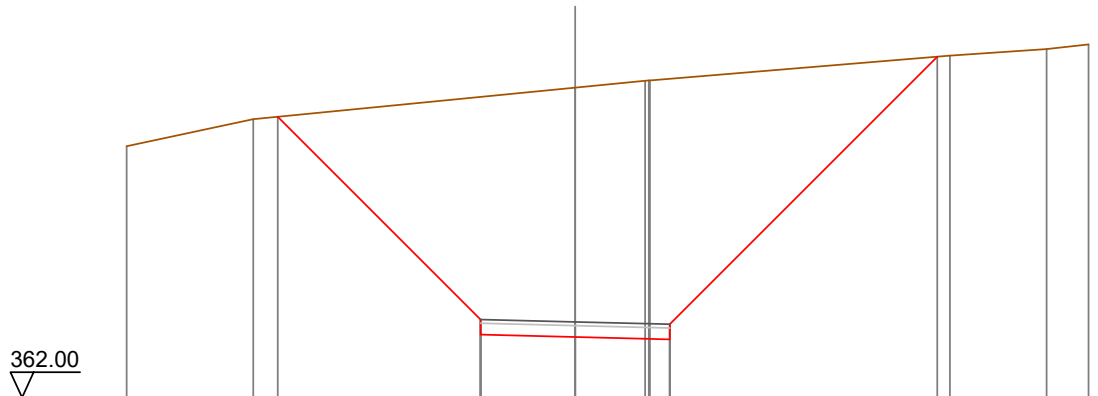

Quote Terreno	-368.65	-369.36	-370.20	-370.38	-370.39	-371.04	-371.22	-371.34
Quote Progetto		369.43	363.66	363.60	363.54	371.01		
Parziali			5.36	2.50	2.50	7.08		
Progressiva		-7.86		-2.50	0.00	2.50		9.58
Dislivelli		0.00		-5.89	-6.60	-6.89		-0.00

Sezione: 79
 Progressiva: 503.268
 Q. Progetto: 364.000

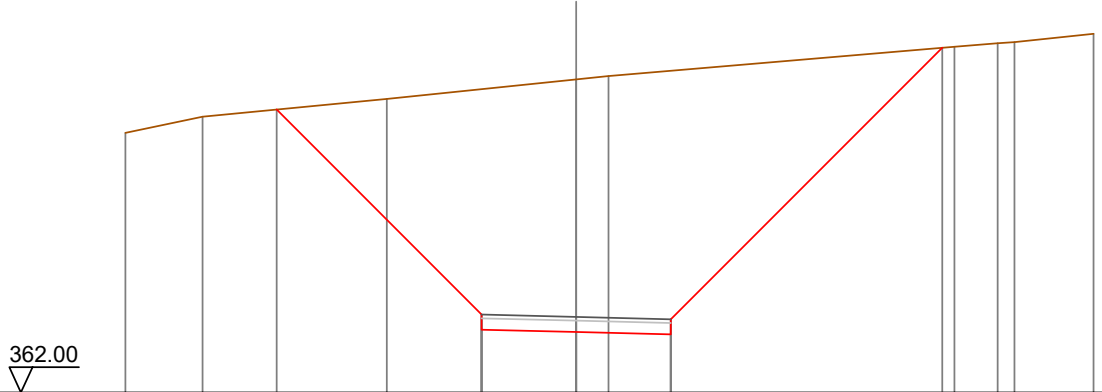

Quote Terreno	-368.87	-369.29	-369.77	-370.28	-370.37	-371.15	-371.24	-371.27	-371.49
Quote Progetto		369.48	363.66	363.60	363.54	371.12			
Parziali			5.42	2.50	2.50	7.18			
Progressiva		-7.92	-2.50	0.00	2.50	9.68			
Dislivelli		0.00	-5.96	-6.68	-6.97	0.00			

Sezione: 80
 Progressiva: 510.000
 Q. Progetto: 364.000

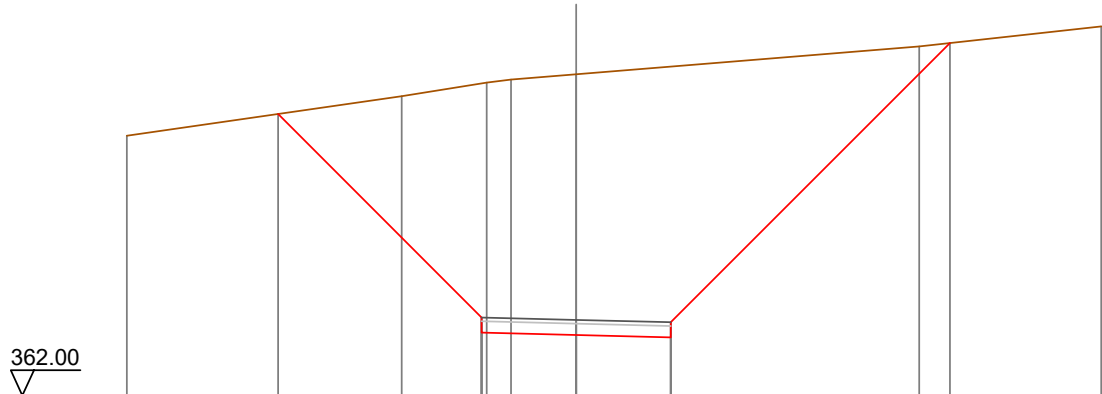

Quote Terreno	-368.87	-369.92	-370.28	-370.36	-370.50	-371.23	-371.76
Quote Progetto		369.45	363.66	363.60	363.54	371.32	
Parziali			5.38	2.50	2.50	7.39	
Progressiva		-7.88	-2.50	0.00	2.50	9.89	
Dislivelli		0.00	-6.19	-6.90	-7.16	0.00	

Sezione: 81
 Progressiva: 515.026
 Q. Progetto: 364.000

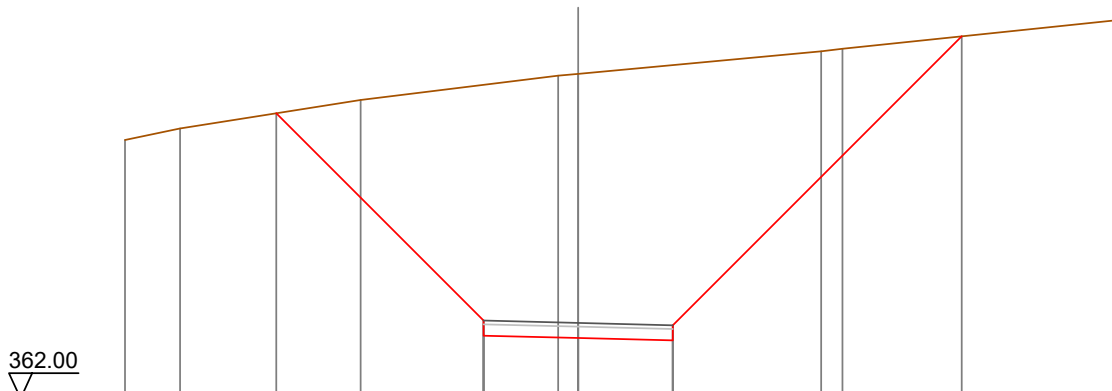

Quote Terreno	-368.84	-369.14	-369.90	-370.54	-370.59	-371.18	-371.25	-372.00
Quote Progetto			369.55	363.66	363.60	363.54		371.58
Parziali			5.48	2.50	2.50	7.64		
Progressiva			-7.98	-2.50	0.00	2.50		10.14
Dislivelli			0.00	-6.23	-6.99	-7.28		0.00

Sezione: 82
 Progressiva: 520.000
 Q. Progetto: 364.000

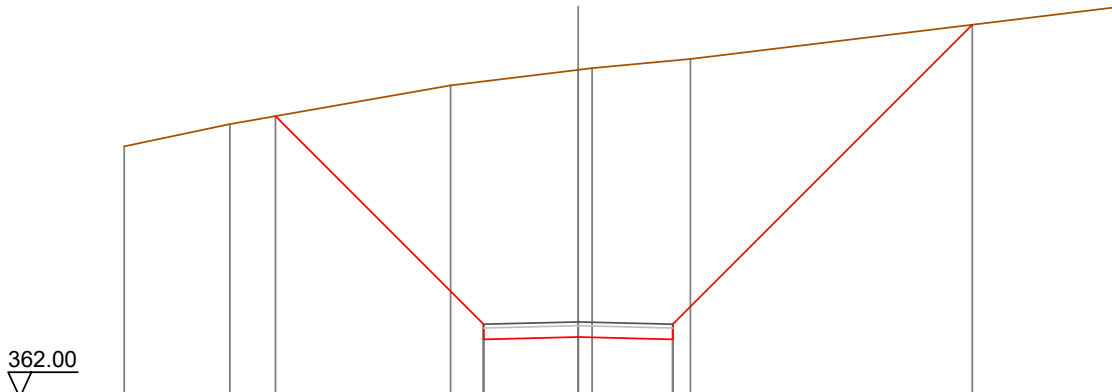

Quote Terreno	-368.64	-369.23	-370.25	-370.67	-370.71	-370.95	-372.31	-372.34
Quote Progetto			369.44	363.54	363.60	363.54		371.86
Parziali			5.50	2.50	2.50	7.92		
Progressiva			-8.00	-2.50	0.00	2.50		10.42
Dislivelli			0.00	-6.42	-7.07	-7.37		-0.00

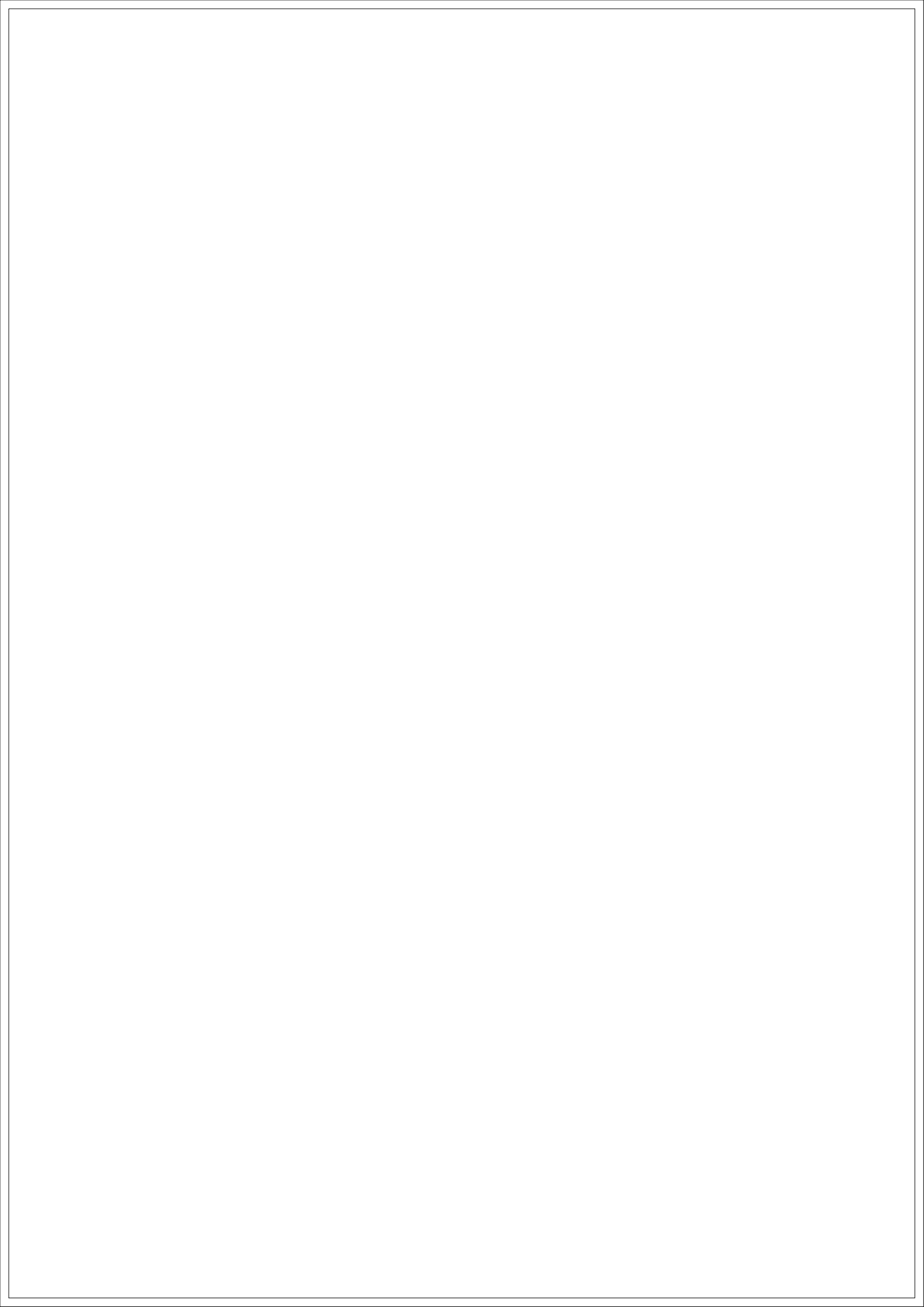

SEZIONI TRASVERSALI
Profilo longitudinale tratto 17-18
Viabilità di impianto-Postazione aerogeneratore VI07

Nota: Le canalette di deflusso delle acque meteoriche, non indicate nel presente elaborato, sono rappresentate graficamente nelle sezioni stradali tipo dell'elaborato "SR-VI-TC12_Piazzole aerogeneratori e strade di servizio - Particolari costruttivi", individuate planimetricamente nell'elaborato "SR-VI-TC13_Opere di regimazione acque superficiali - Planimetria generale" e quantificate nell'elaborato "SR-VI-RC6_Computo Metrico Estimativo opere civili".

DISEGNI DI RIFERIMENTO

TAVOLA	DESCRIZIONE
SR-VI-TC8.1	Piazzole e viabilità - Planimetria di progetto - Fase di cantiere
SR-VI-TC10	Profili longitudinali viabilità di impianto
SR-VI-TC12	Piazzole aerogeneratori e strade di servizio - Particolari costruttivi
SR-VI-TC13	Opere di regimazione acque superficiali - Planimetria generale

Sezione: 4
 Progressiva: 20.000
 Q. Progetto: 364.000

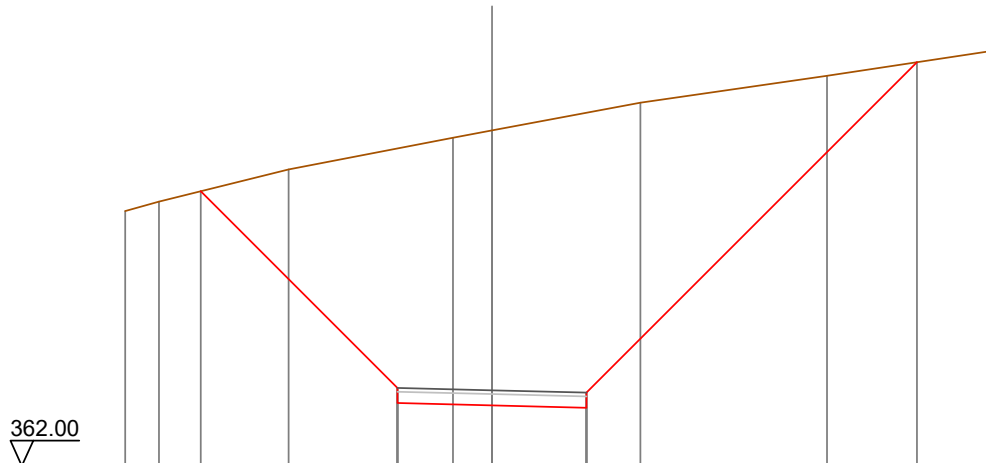

Quote Terreno		368.74	368.99	369.84	370.68	370.87	371.61	372.32	372.98
Quote Progetto			369.26		363.66	363.60	363.54		372.68
Parziali				5.20	2.50	2.50		8.74	
Progressiva			-7.70		-2.50	0.00	2.50		11.24
Dislivelli			0.00		-6.33	-7.27	-7.80		0.00

Sezione: 5
 Progressiva: 23.985
 Q. Progetto: 364.000

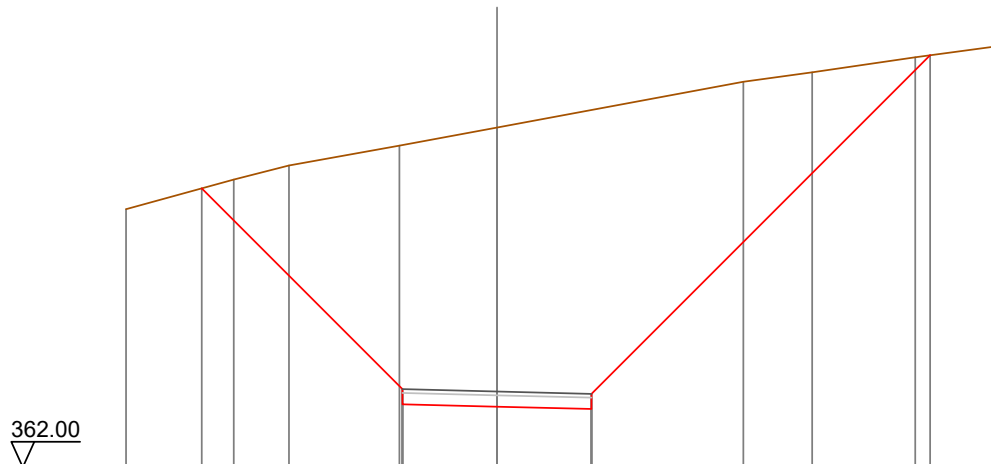

Quote Terreno		368.82	369.61	369.98	370.50	370.98		372.19	372.44	372.84	373.16
Quote Progetto			369.37		363.66	363.60	363.54			372.89	
Parziali				5.31	2.50	2.50		8.96			
Progressiva			-7.81		-2.50	0.00	2.50			11.46	
Dislivelli			-0.00		-6.46	-7.38	-7.91			-0.00	

Sezione: 6
 Progressiva: 30.000
 Q. Progetto: 364.008

362.00

Quote Terreno	369.06	370.14	371.12	371.42	371.77	372.50	372.90	373.45
Quote Progetto		369.56	363.67	363.61	363.55			373.19
Parziali		5.49	2.50	2.50		9.25		
Progressiva		-7.99	-2.50	0.00	2.50			11.75
Dislivelli	0.00		-6.86	-7.81	-8.29			0.00

Sezione: 7
 Progressiva: 40.000
 Q. Progetto: 364.164

362.00

Quote Terreno	369.54	370.18		371.88	372.00	372.33	372.45	372.92	373.80	374.07
Quote Progetto		370.14	363.83	363.76	363.70				373.75	
Parziali		5.91	2.50	2.50		9.65				
Progressiva		-8.41	-2.50	0.00	2.50				12.15	
Dislivelli	0.00		-7.14	-8.12	-8.68				-0.00	

Sezione: 8
 Progressiva: 42.748
 Q. Progetto: 364.242

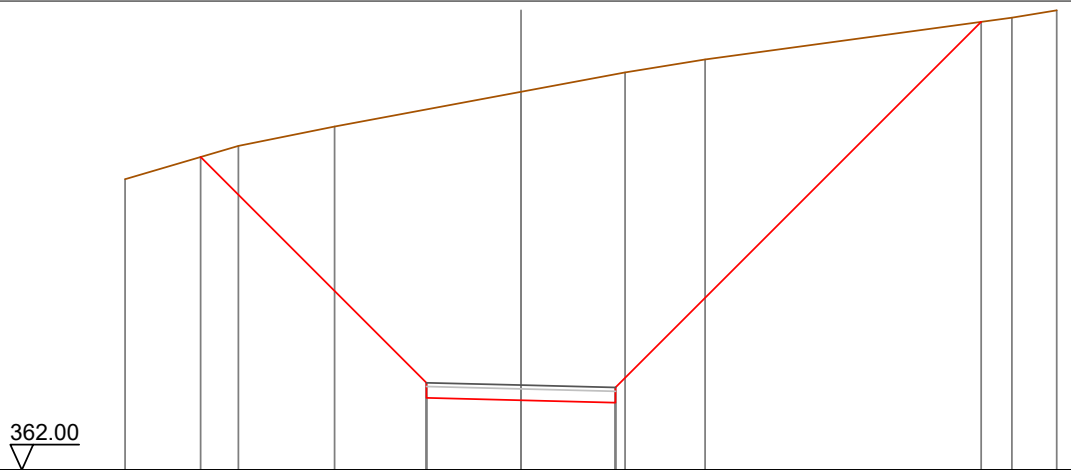

Quote Terreno	369.69	370.57	371.08	372.00	372.51	372.96	373.96	374.15
Quote Progetto		370.28		363.90	363.84	363.78		373.85
Parziali			5.97	2.50	2.50		9.67	
Progressiva		-8.47		-2.50	0.00	2.50		12.17
Dislivelli		0.00		-7.23	-8.16	-8.68		0.00

Sezione: 9
 Progressiva: 60.000
 Q. Progetto: 364.791

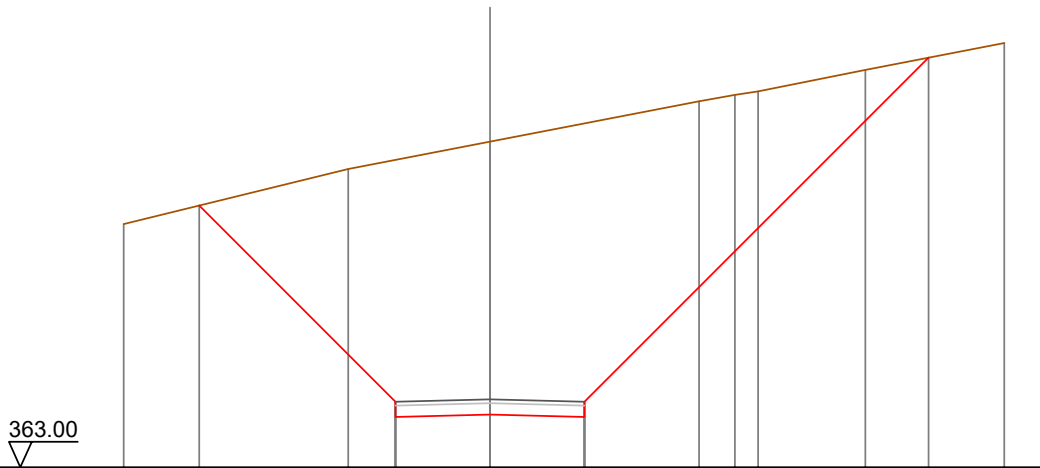

Quote Terreno	369.43	370.89	371.61	372.66	372.84	372.94	373.51	374.22
Quote Progetto		369.92	364.33	364.39	364.33		373.83	
Parziali			5.19	2.50	2.50		9.10	
Progressiva		-7.69		-2.50	0.00	2.50		11.60
Dislivelli		0.00		-6.40	-7.22	-7.76		0.00

Sezione: 10
 Progressiva: 80.000
 Q. Progetto: 365.427

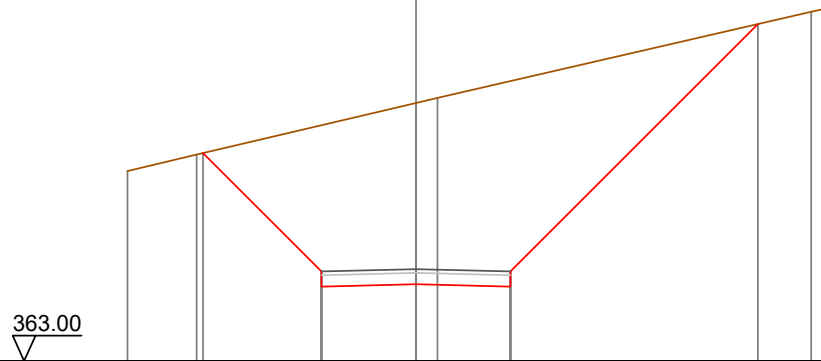

Quote Terreno	368.02	368.46	369.82	369.96	372.23	372.36
Quote Progetto		368.50	364.96	365.03	364.96	371.91
Parziali		3.13	2.50	2.50	6.54	
Progressiva		-5.63	-2.50	0.00	2.50	9.04
Dislivelli		-0.00	-3.87	-4.80	-5.44	0.00

Sezione: 11
 Progressiva: 82.488
 Q. Progetto: 365.507

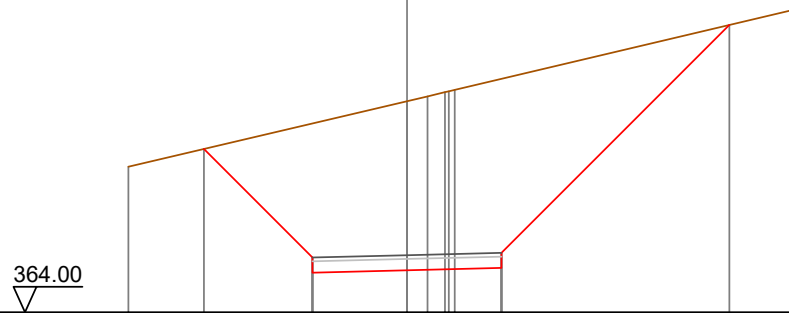

Quote Terreno	367.84	368.31	369.59	369.71	369.88	372.07
Quote Progetto		368.31	365.04	365.11	365.17	371.60
Parziali		2.87	2.50	2.50	6.03	
Progressiva		-5.37	-2.50	0.00	2.50	8.53
Dislivelli		0.00	-3.55	-4.47	-5.00	0.00

Sezione: 14
 Progressiva: 100.000
 Q. Progetto: 366.054

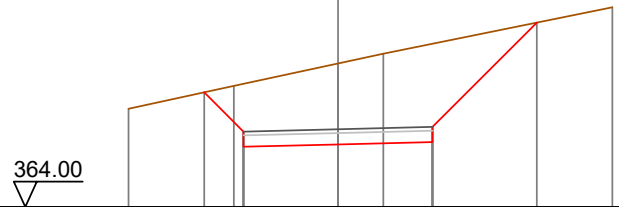

Quote Terreno	366.60	367.20	367.79	368.05	369.28	
Quote Progetto		367.03	365.59	365.65	365.72	368.87
Parziali		1.04	2.50	2.50	2.76	
Progressiva		-3.54	-2.50	0.00	2.50	5.26
Dislivelli		0.00	-1.26	-2.14	-2.60	0.00

Sezione: 15
 Progressiva: 108.455
 Q. Progetto: 366.197

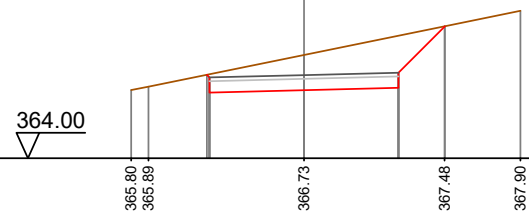

Quote Terreno	365.80	365.29	366.73	367.48	367.90	
Quote Progetto		366.20	365.73	365.80	367.49	
Parziali			2.50	2.50	1.23	
Progressiva		-2.57	-2.50	0.00	2.50	3.73
Dislivelli		0.00	-0.08	-0.93	-1.38	0.00

Sezione: 16
 Progressiva: 120.000
 Q. Progetto: 366.162

363.00

Quote Terreno	364.24		365.09	365.41	365.53	365.67	366.47
Quote Progetto		364.67	365.70		365.76		365.70 366.06
Parziali		1.43	2.50		2.50		
Progressiva		-3.93	-2.50	0.00	2.50	2.54	
Dislivelli		0.00	1.12	0.23	-0.35	-0.00	

Sezione: 17
 Progressiva: 124.961
 Q. Progetto: 366.066

362.00

Quote Terreno	363.76		365.01	365.19		366.19
Quote Progetto		364.22	365.60	365.67	365.73 365.78	
Parziali		1.78	2.50	2.50	0.35	
Progressiva		-4.28	-2.50	0.00	2.50 2.85	
Dislivelli		0.00	1.37	0.48	0.02 0.00	

Sezione: 18
 Progressiva: 130.000
 Q. Progetto: 365.945

362.00

Quote Terreno		363.39	363.83	364.61	364.79	365.16	365.84
Quote Progetto			363.80	365.48	365.54	365.61	365.42
Parziali			2.08	2.50	2.50	0.59	
Progressiva			-4.58	-2.50	0.00	2.50	3.09
Dislivelli			-0.00	1.63	0.76	0.32	0.00

Sezione: 19
 Progressiva: 140.000
 Q. Progetto: 365.705

361.00

Quote Terreno		362.43	362.55	362.82	363.86	363.98	364.94
Quote Progetto			362.81	365.24	365.31	365.37	364.56
Parziali			2.83	2.50	2.50	1.21	
Progressiva			-5.33	-2.50	0.00	2.50	3.71
Dislivelli			-0.00	2.28	1.45	1.03	-0.00

Sezione: 20
 Progressiva: 143.159
 Q. Progetto: 365.629

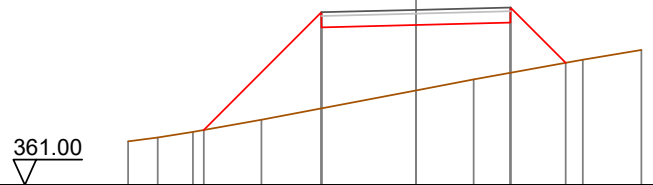

Quote Terreno	362.15	362.25	362.40	362.72	363.50	363.79	364.31	364.57
Quote Progetto			362.45		365.17	365.23	365.29	364.23
Parziali				3.11	2.50	2.50	1.46	
Progressiva			-5.61		-2.50	0.00	2.50	3.96
Dislivelli			0.00		2.54	1.73	1.33	-0.00

Sezione: 20
 Progressiva: 143.159
 Q. Progetto: 365.629

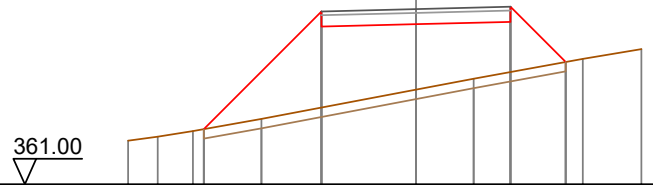

Quote Terreno	362.15	362.25	362.40	362.72	363.50	363.79	364.31	364.57
Quote Progetto			362.45		365.17	365.23	365.29	364.23
Parziali				3.11	2.50	2.50	1.46	
Progressiva			-5.61		-2.50	0.00	2.50	3.96
Dislivelli			0.00		2.54	1.73	1.33	0.00

Sezione: 21
 Progressiva: 148.780
 Q. Progetto: 365.495

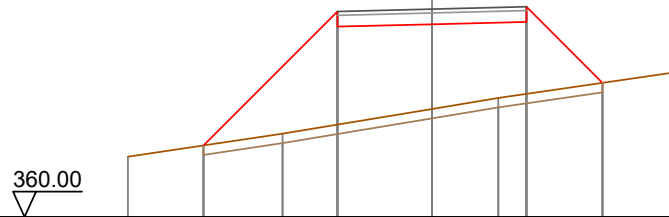

Quote Terreno	361.59		362.20		362.86		363.15		363.84
Quote Progetto		361.89		365.03		365.09		365.16	363.55
Parziali			3.54		2.50		2.50		2.01
Progressiva		-6.04		-2.50		0.00		2.50	4.51
Dislivelli		0.00		2.99		2.24		1.90	0.00

Sezione: 22
 Progressiva: 150.000
 Q. Progetto: 365.465

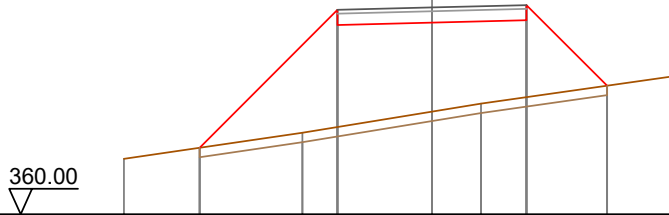

Quote Terreno	361.46		362.15		362.71		362.92		363.68
Quote Progetto		361.76		365.00		365.07		365.13	363.40
Parziali			3.65		2.50		2.50		2.13
Progressiva		-6.15		-2.50		0.00		2.50	4.63
Dislivelli		-0.00		3.10		2.35		2.03	0.00

Sezione: 23
 Progressiva: 160.000
 Q. Progetto: 365.311

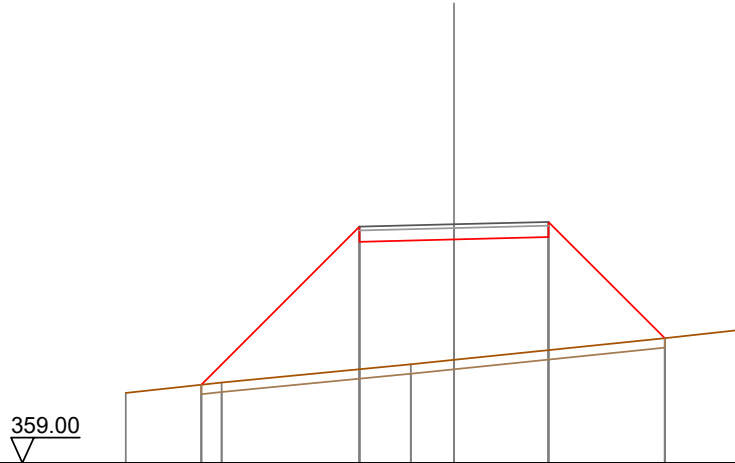

Quote Terreno		360.85	361.12	361.61	361.73	364.97	362.30	362.52
Quote Progetto			361.07	364.85	364.91	364.97	362.30	
Parziali			4.18	2.50	2.50	3.07		
Progressiva			-6.68	-2.50	0.00	2.50	5.57	
Dislivelli			-0.00	3.77	3.19	2.99	0.00	

Sezione: 24
 Progressiva: 170.000
 Q. Progetto: 365.356

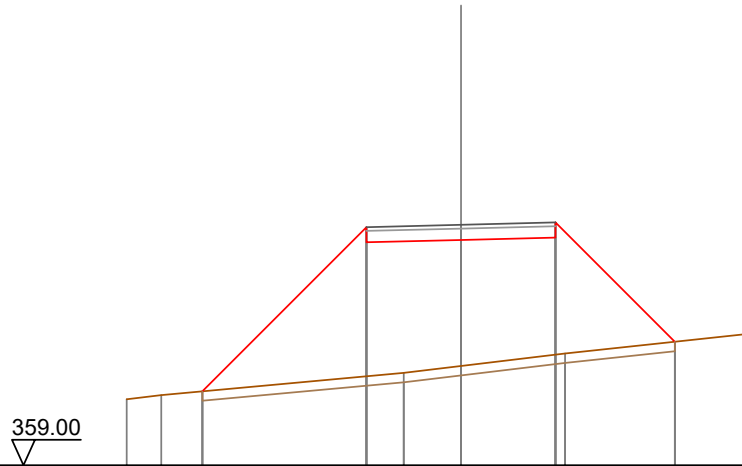

Quote Terreno		360.74	360.85	361.44	361.62	361.95	362.48
Quote Progetto			360.95	364.89	364.96	365.02	362.26
Parziali			4.34	2.50	2.50	3.16	
Progressiva			-6.84	-2.50	0.00	2.50	5.66
Dislivelli			0.00	3.94	3.34	3.10	0.00

Sezione: 25
 Progressiva: 172.600
 Q. Progetto: 365.401

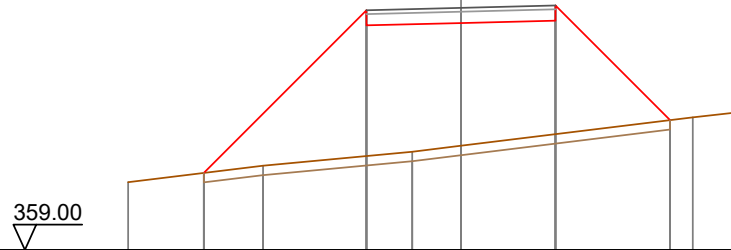

Quote Terreno		360.79		361.23		361.60		361.75				362.51		362.66
Quote Progetto			361.04		364.94		365.00		365.06			362.43		
Parziali				4.30		2.50		2.50		3.03				
Progressiva			-6.80		-2.50		0.00		2.50		5.53			
Dislivelli			0.00		3.86		3.25		3.00		0.00			

Sezione: 26
 Progressiva: 180.000
 Q. Progetto: 365.591

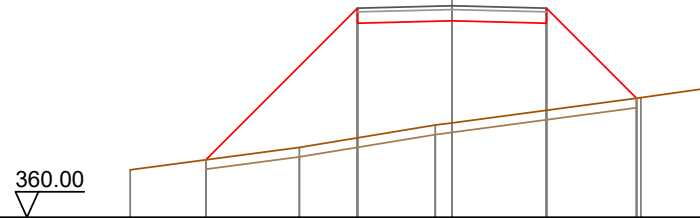

Quote Terreno		361.25		361.85		362.43		362.49				363.16		363.42
Quote Progetto			361.52		365.13		365.19		365.13			363.14		
Parziali				4.01		2.50		2.50		2.38				
Progressiva			-6.51		-2.50		0.00		2.50		4.88			
Dislivelli			0.00		3.43		2.70		2.30		0.00			

Sezione: 27
 Progressiva: 184.026
 Q. Progetto: 365.703

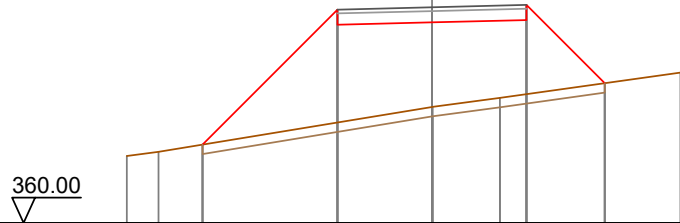

Quote Terreno		361.77	361.88		363.07	363.31		363.98
Quote Progetto			362.07		365.24	365.30	365.37	363.70
Parziali				3.57	2.50	2.50	2.07	
Progressiva			-6.07		-2.50	0.00	2.50	4.57
Dislivelli			0.00		2.99	2.24	1.96	0.00

Sezione: 28
 Progressiva: 190.000
 Q. Progetto: 365.870

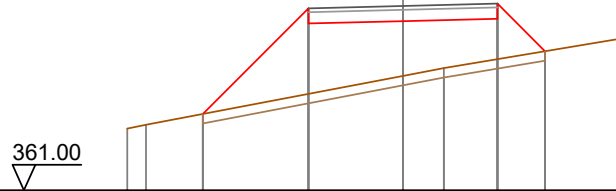

Quote Terreno		362.63	362.73		364.02	364.23		365.01
Quote Progetto				363.01	365.41	365.47	365.53	364.67
Parziali				2.79	2.50	2.50	1.26	
Progressiva			-5.29		-2.50	0.00	2.50	3.76
Dislivelli			-0.00		2.26	1.45	1.07	0.00

Sezione: 29
 Progressiva: 199.260
 Q. Progetto: 366.128

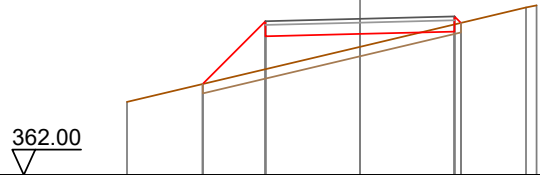

Quote Terreno		363.93			365.39		366.43	366.48
Quote Progetto			364.40	365.67	365.73		365.79	366.02
Parziali			1.66	2.50	2.50			
Progressiva			-4.16	-2.50	0.00		2.50	2.67
Dislivelli			0.00	1.27	0.34		-0.19	0.00

Sezione: 30
 Progressiva: 200.000
 Q. Progetto: 366.149

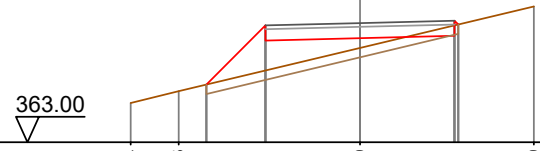

Quote Terreno		364.04	364.35		365.49		366.59	
Quote Progetto			364.52	365.69	365.75		365.81	366.11
Parziali			1.56	2.50	2.50			
Progressiva			-4.06	-2.50	0.00		2.50	2.60
Dislivelli			0.00	1.19	0.26		-0.28	0.00

Sezione: 31
 Progressiva: 203.159
 Q. Progetto: 366.237

363.00

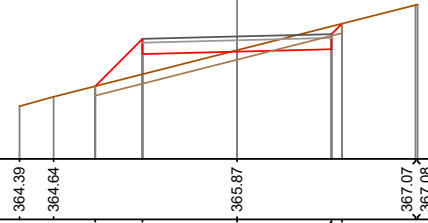

Quote Terreno		364.39	364.64			365.84		367.07	367.08
Quote Progetto				364.92	365.77		365.84	365.90	366.58
Parziali				1.25	2.50		2.50	0.28	
Progressiva			-3.75	-2.50		0.00	2.50	2.78	
Dislivelli			0.00	0.93		-0.04	-0.61	-0.00	

Sezione: 31
 Progressiva: 203.159
 Q. Progetto: 366.237

363.00

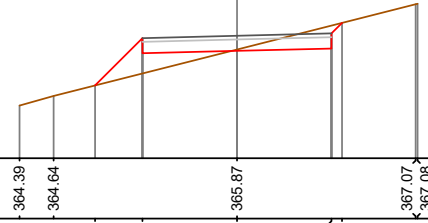

Quote Terreno		364.39	364.64			365.84		367.07	367.08
Quote Progetto				364.92	365.77		365.84	365.90	366.58
Parziali				1.25	2.50		2.50	0.28	
Progressiva			-3.75	-2.50		0.00	2.50	2.78	
Dislivelli			0.00	0.93		-0.04	-0.61	-0.00	

Sezione: 32
 Progressiva: 210.000
 Q. Progetto: 366.428

363.00

Quote Terreno	364.90	365.51	366.25	366.45	367.88	367.89
Quote Progetto		365.48	365.97	366.03	366.09	367.35
Parziali		0.88	2.50	2.50	0.86	
Progressiva		-3.38	-2.50	0.00	2.50	3.36
Dislivelli		0.00	0.63	-0.42	-1.03	0.00

Sezione: 33
 Progressiva: 214.493
 Q. Progetto: 366.555

364.00

Quote Terreno	365.07	365.66	366.16	366.64	367.51	368.02	368.22
Quote Progetto		365.66	366.09	366.16	366.22	367.68	
Parziali		0.84	2.50	2.50	1.06		
Progressiva		-3.34	-2.50	0.00	2.50	3.56	
Dislivelli		0.00	0.59	-0.49	-1.16	0.00	

Sezione: 34
 Progressiva: 220.000
 Q. Progetto: 366.754

364.00

Quote Terreno	365.04	365.05		366.69	366.89	368.03	368.34
Quote Progetto			365.63	366.29	366.35	366.29	367.77
Parziali			1.06	2.50	2.50	1.07	
Progressiva			-3.56	-2.50	0.00	2.50	3.57
Dislivelli			0.00	0.74	-0.34	-1.15	0.00

Sezione: 35
 Progressiva: 221.531
 Q. Progetto: 366.820

363.00

Quote Terreno	364.95	365.45		366.37	366.70	368.02	368.34
Quote Progetto			365.56	366.48	366.42	366.36	367.75
Parziali			1.33	2.50	2.50	0.99	
Progressiva			-3.83	-2.50	0.00	2.50	3.49
Dislivelli			-0.00	0.93	-0.28	-1.09	-0.00

Sezione: 36
 Progressiva: 228.583
 Q. Progetto: 367.185

364.00

Quote Terreno	365.05	365.78	366.90	367.31	367.94	368.44
Quote Progetto		365.67	366.85	366.79	366.72	367.86
Parziali		1.57	2.50	2.50	0.74	
Progressiva		-4.07	-2.50	0.00	2.50	3.24
Dislivelli		0.00	1.10	-0.11	-0.92	0.00

Sezione: 37
 Progressiva: 230.000
 Q. Progetto: 367.271

364.00

Quote Terreno	365.14	365.76	366.97	367.36	367.92	368.49
Quote Progetto		365.76	366.93	366.87	366.81	367.93
Parziali		1.58	2.50	2.50	0.72	
Progressiva		-4.08	-2.50	0.00	2.50	3.22
Dislivelli		0.00	1.11	-0.10	-0.91	0.00

Sezione: 38
 Progressiva: 235.635
 Q. Progetto: 367.650

364.00

Quote Terreno	365.65	365.73		367.30	368.70
Quote Progetto		366.20	367.31	367.25	367.19
Parziali		1.51	2.50	2.50	0.56
Progressiva		-4.01	-2.50	0.00	2.50
Dislivelli		0.00	1.10	-0.05	-0.80

Sezione: 39
 Progressiva: 240.000
 Q. Progetto: 367.988

365.00

Quote Terreno	366.29	366.76		367.84	369.33
Quote Progetto		366.85	367.53	367.59	367.53
Parziali		1.07	2.50	2.50	0.85
Progressiva		-3.57	-2.50	0.00	2.50
Dislivelli		0.00	0.78	-0.26	-1.01

Sezione: 40
 Progressiva: 248.734
 Q. Progetto: 368.781

366.00

Quote Terreno	367.59	368.13	368.89	368.95	370.11	370.38
Quote Progetto		368.12	368.32	368.38	368.44	369.85
Parziali		0.60	2.50	2.50	1.01	
Progressiva		-3.10	-2.50	0.00	2.50	3.51
Dislivelli		-0.00	0.45	-0.51	-1.13	-0.00

Sezione: 41
 Progressiva: 250.000
 Q. Progetto: 368.907

366.00

Quote Terreno	367.76	368.17	369.05	369.27	370.13	370.54
Quote Progetto		368.28	368.51	368.57	370.02	
Parziali		0.57	2.50	2.50	1.05	
Progressiva		-3.07	-2.50	0.00	2.50	3.55
Dislivelli		0.00	0.42	-0.55	-1.16	0.00

Sezione: 42
 Progressiva: 257.664
 Q. Progetto: 369.675

367.00

Quote Terreno	368.48	368.83	369.86	371.39
Quote Progetto		369.02 369.21	369.28	369.34 370.84
Parziali		0.60 2.50	2.50	1.10
Progressiva		-3.10 -2.50	0.00	2.50 3.60
Dislivelli		0.00 0.43	-0.58	-1.20 0.00

Sezione: 43
 Progressiva: 260.000
 Q. Progetto: 369.910

367.00

Quote Terreno	368.65	369.98	370.03	371.55
Quote Progetto		369.19 369.45	369.51	369.57 371.00
Parziali		0.66 2.50	2.50	1.03
Progressiva		-3.16 -2.50	0.00	2.50 3.53
Dislivelli		0.00 0.48	-0.52	-1.15 -0.00

Sezione: 44
 Progressiva: 263.159
 Q. Progetto: 370.240

367.00

Quote Terreno	-368.92	-369.57	-370.26	-371.75
Quote Progetto	-369.38	-369.78	-369.84	-369.90
Parziali	0.79	2.50	2.50	0.89
Progressiva	-3.29	-2.50	0.00	2.50
Dislivelli	0.00	0.61	-0.42	-1.05

Sezione: 44
 Progressiva: 263.159
 Q. Progetto: 370.240

367.00

Quote Terreno	-368.92	-369.57	-370.26	-371.75
Quote Progetto	-369.38	-369.78	-369.84	-369.90
Parziali	0.79	2.50	2.50	0.89
Progressiva	-3.29	-2.50	0.00	2.50
Dislivelli	0.00	0.61	-0.42	-1.05

Sezione: 45
 Progressiva: 266.594
 Q. Progetto: 370.622

368.00

Quote Terreno	369.20			370.47	370.65	370.92		371.88
Quote Progetto		369.67	370.16	370.22		370.28	371.32	
Parziali		0.89	2.50		2.50		0.63	
Progressiva		-3.39	-2.50	0.00		2.50	3.13	
Dislivelli		-0.00	0.68	-0.25		-0.86	-0.00	

Sezione: 46
 Progressiva: 267.882
 Q. Progetto: 370.771

368.00

Quote Terreno	369.26			370.56	370.70	370.90	371.09	371.98
Quote Progetto		369.74	370.43	370.37		370.31	371.41	
Parziali		1.10	2.50		2.50		0.70	
Progressiva		-3.60	-2.50	0.00		2.50	3.20	
Dislivelli		0.00	0.84	-0.21		-0.90	0.00	

Sezione: 47
 Progressiva: 270.000
 Q. Progetto: 371.024

368.00

Quote Terreno		369.47		370.39	370.81	371.12		372.18
Quote Progetto			369.94	370.69	370.62		370.56	371.64
Parziali			1.15	2.50	2.50		0.68	
Progressiva			-3.65	-2.50	0.00		2.50	3.18
Dislivelli			-0.00	0.88	-0.18		-0.89	-0.00

Sezione: 48
 Progressiva: 280.000
 Q. Progetto: 372.343

370.00

Quote Terreno		371.30		371.95	372.19	372.20	372.57		373.32
Quote Progetto			371.61	372.01	371.94		371.88	372.87	
Parziali			0.79	2.50	2.50		0.59		
Progressiva			-3.29	-2.50	0.00		2.50	3.09	
Dislivelli			0.00	0.67	-0.26		-0.86	-0.00	

Sezione: 49
 Progressiva: 290.000
 Q. Progetto: 373.868

372.00

Quote Terreno	373.72	373.82	374.26	374.71	375.00
Quote Progetto		373.53	373.47	373.41	374.67
Parziali		2.50	2.50	0.87	
Progressiva		-2.52	0.00	2.50	3.37
Dislivelli		0.00	-0.79	-1.16	-0.00

Sezione: 50
 Progressiva: 300.000
 Q. Progetto: 375.508

374.00

Quote Terreno	375.75	375.83	375.99	376.14	376.69
Quote Progetto		375.91	375.17	375.11	375.05
Parziali		0.34	2.50	2.50	1.05
Progressiva		-2.84	-2.50	0.00	2.50
Dislivelli		0.00	-0.36	-1.03	-1.34

Sezione: 51
 Progressiva: 301.094
 Q. Progetto: 375.681

374.00

Quote Terreno	-375.96	-376.05	-376.14	-376.96	-376.89
Quote Progetto			375.11 375.34	375.28	375.22 376.70
Parziali			0.37 2.50	2.50	1.08
Progressiva			-2.87 -2.50	0.00	2.50 3.58
Dislivelli			0.00 -0.39	-1.08	-1.38 0.00

Sezione: 52
 Progressiva: 310.000
 Q. Progetto: 376.995

375.00

Quote Terreno	-376.91	-376.98	-377.43	-377.93	-378.02
Quote Progetto			377.10 376.66	376.53 377.86	
Parziali			2.50	2.50	0.93
Progressiva			-2.55 -2.50	0.00	2.50 3.43
Dislivelli			0.00 -0.05	-0.83	-1.21 0.00

Sezione: 53
 Progressiva: 320.000
 Q. Progetto: 378.276

376.00

Quote Terreno	377.08	377.16	377.37	377.83	378.70
Quote Progetto			377.36	377.94	377.81
Parziali			0.98	2.50	2.50
Progressiva			-3.48	-2.50	0.00
Dislivelli			0.00	0.82	-0.05

Sezione: 54
 Progressiva: 323.159
 Q. Progetto: 378.638

376.00

Quote Terreno	377.20			378.21	378.55	378.95	378.96
Quote Progetto			377.56	378.30	378.24	378.18	378.66
Parziali			1.14	2.50	2.50		
Progressiva			-3.64	-2.50	0.00	2.50	2.58
Dislivelli			0.00	0.94	0.03	-0.47	0.00

Sezione: 54
 Progressiva: 323.159
 Q. Progetto: 378.638

376.00

Quote Terreno	377.20			378.21	378.55	378.95	378.96
Quote Progetto		377.56	378.30	378.24	378.18	378.66	
Parziali		1.14	2.50	2.50			
Progressiva		-3.64	-2.50	0.00	2.50	2.58	
Dislivelli		0.00	0.94	0.03	-0.47	0.00	

Sezione: 55
 Progressiva: 330.000
 Q. Progetto: 379.364

376.00

Quote Terreno	377.65			378.73	379.08	379.57	
Quote Progetto		378.01	379.03	378.96	378.90	379.21	
Parziali		1.41	2.50	2.50			
Progressiva		-3.91	-2.50	0.00	2.50	2.59	
Dislivelli		0.00	1.15	0.23	-0.29	0.00	

Sezione: 56
 Progressiva: 334.307
 Q. Progetto: 379.814

377.00

Quote Terreno	378.32			379.18	379.24	379.47	380.00
Quote Progetto		378.64	379.48	379.41		379.35	379.66
Parziali		1.24	2.50	2.50			
Progressiva		-3.74	-2.50	0.00		2.50	2.59
Dislivelli		0.00	1.04	0.18		-0.29	0.00

Sezione: 57
 Progressiva: 338.103
 Q. Progetto: 380.210

377.00

Quote Terreno	378.91			379.77		380.49	
Quote Progetto		379.23	379.75	379.81	379.87	380.18	
Parziali		0.91	2.50	2.50			
Progressiva		-3.41	-2.50	0.00		2.50	2.60
Dislivelli		-0.00	0.77	0.04		-0.29	0.00

Sezione: 58
 Progressiva: 340.000
 Q. Progetto: 380.408

378.00

Quote Terreno	379.16	379.45	380.03	380.50	380.78	
Quote Progetto		379.49	379.95	380.01	380.07	380.44
Parziali		0.86	2.50	2.50		
Progressiva		-3.36	-2.50	0.00	2.50	2.53
Dislivelli		0.00	0.72	-0.02	-0.37	0.00

Sezione: 59
 Progressiva: 346.652
 Q. Progetto: 381.102

379.00

Quote Terreno	380.02	380.40	380.64	380.70	381.00	381.77	381.93
Quote Progetto		380.40	380.64	380.70	380.76	381.55	
Parziali		0.64	2.50	2.50	0.38		
Progressiva		-3.14	-2.50	0.00	2.50	2.88	
Dislivelli		0.00	0.52	-0.30	-0.71	-0.00	

Sezione: 60
 Progressiva: 350.000
 Q. Progetto: 381.451

379.00

Quote Terreno	380.42	380.87	381.44	382.09	382.47
Quote Progetto		380.82 380.99	381.05	381.11 382.06	
Parziali		0.57	2.50	2.50	0.55
Progressiva		-3.07 -2.50	0.00	2.50 3.05	
Dislivelli		0.00 0.45	-0.39	-0.84 0.00	

Sezione: 61
 Progressiva: 355.202
 Q. Progetto: 381.994

379.00

Quote Terreno	380.96		382.01 382.07	382.46	383.19
Quote Progetto		381.40 381.53	381.59 382.07	381.66 382.76	
Parziali		0.53	2.50	2.50	0.70
Progressiva		-3.03 -2.50	0.00	2.50 3.20	
Dislivelli		0.00 0.41	-0.47	-0.95 0.00	

Sezione: 62
 Progressiva: 360.000
 Q. Progetto: 382.495

▽ 380.00

Quote Terreno	381.37	381.45			382.55	382.76		383.72
Quote Progetto			381.83	382.03	382.09		382.03	383.28
Parziali			0.60	2.50	2.50		0.85	
Progressiva			-3.10	-2.50	0.00		2.50	3.35
Dislivelli			0.00	0.46	-0.45		-1.07	0.00

Sezione: 63
 Progressiva: 376.351
 Q. Progetto: 384.430

▽ 381.00

Quote Terreno	382.99	383.44	383.77	384.28		385.18	385.48
Quote Progetto		383.46	384.09	384.03	383.97	385.01	
Parziali		1.03	2.50	2.50	0.64		
Progressiva		-3.53	-2.50	0.00	2.50	3.14	
Dislivelli		0.00	0.80	-0.25	-0.89	-0.00	

Sezione: 64
 Progressiva: 380.000
 Q. Progetto: 384.937

382.00

Quote Terreno	383.53	384.06	384.75	385.61	385.88
Quote Progetto		383.96	384.60	384.54	384.47
Parziali		1.04	2.50	2.50	0.56
Progressiva		-3.54	-2.50	0.00	2.50
Dislivelli		-0.00	0.81	-0.21	-0.83

Sezione: 65
 Progressiva: 390.000
 Q. Progetto: 386.465

384.00

Quote Terreno	385.39	385.93	386.33	387.27
Quote Progetto		385.73	386.07	386.00
Parziali		0.80	2.50	2.50
Progressiva		-3.30	-2.50	0.00
Dislivelli		0.00	0.66	-0.27

Sezione: 66
 Progressiva: 392.045
 Q. Progetto: 386.803

▽ 384.00

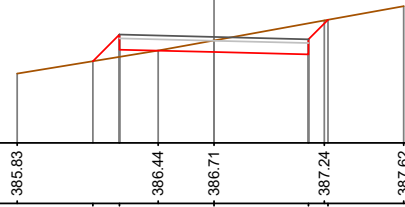

Quote Terreno	385.83		386.44	386.71	387.24	387.62
Quote Progetto		386.16	386.47	386.40	386.34	387.26
Parziali		0.71	2.50	2.50	0.52	
Progressiva		-3.21	-2.50	0.00	2.50	3.02
Dislivelli		0.00	0.59	-0.31	-0.82	0.00

Sezione: 67
 Progressiva: 392.728
 Q. Progetto: 386.918

▽ 384.00

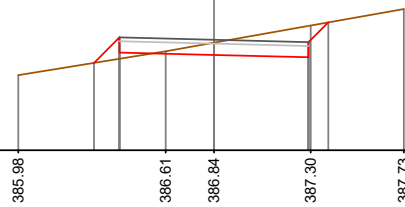

Quote Terreno	385.98		386.61	386.84	387.30	387.73
Quote Progetto		386.31	386.58	386.52	386.46	387.38
Parziali		0.67	2.50	2.50	0.52	
Progressiva		-3.17	-2.50	0.00	2.50	3.02
Dislivelli		-0.00	0.57	-0.32	-0.83	0.00

Sezione: 67
 Progressiva: 392.728
 Q. Progetto: 386.918

384.00

Quote Terreno	385.98		386.61	386.84	387.30	387.73
Quote Progetto		386.31	386.58	386.52	386.46	387.38
Parziali		0.67	2.50	2.50	0.52	
Progressiva		-3.17	-2.50	0.00	2.50	3.02
Dislivelli		0.00	0.57	-0.32	-0.83	0.00

Sezione: 68
 Progressiva: 400.000
 Q. Progetto: 388.194

386.00

Quote Terreno	387.63		387.97	388.27	388.72	388.96
Quote Progetto		387.90	387.86	387.79	387.73	388.68
Parziali		0.36	2.50	2.50	0.55	
Progressiva		-2.86	-2.50	0.00	2.50	3.05
Dislivelli		0.00	0.31	-0.48	-0.87	0.00

Sezione: 69
 Progressiva: 407.739
 Q. Progetto: 389.537

388.00

Quote Terreno	389.20	389.40	389.71	390.16	390.21
Quote Progetto		389.44 389.20	389.14	389.07 390.02	
Parziali			2.50	2.50	0.55
Progressiva		-2.66 -2.50	0.00	2.50 3.05	
Dislivelli		-0.00 0.14	-0.57	-0.89 -0.00	

Sezione: 70
 Progressiva: 409.419
 Q. Progetto: 389.812

388.00

Quote Terreno	389.45	389.84	389.98	390.25	390.46
Quote Progetto		389.69 389.47	389.41	389.35 390.29	
Parziali			2.50	2.50	0.54
Progressiva		-2.69 -2.50	0.00	2.50 3.04	
Dislivelli		0.00 0.17	-0.57	-0.89 0.00	

Sezione: 71
 Progressiva: 410.000
 Q. Progetto: 389.906

388.00

Quote Terreno	389.54	389.99	390.08	390.28	390.53
Quote Progetto		389.78 389.57	389.51	389.44 390.37	
Parziali			2.50	2.50	0.52
Progressiva		-2.69 -2.50	0.00	2.50 3.02	
Dislivelli		0.00 0.17	-0.57	-0.88 0.00	

Sezione: 72
 Progressiva: 420.000
 Q. Progetto: 391.414

389.00

Quote Terreno	391.03	391.45	391.87
Quote Progetto		391.21 391.08	391.01 390.95 391.69
Parziali		0.27 2.50	2.50 0.34
Progressiva		-2.77 -2.50	0.00 2.50 2.84
Dislivelli		0.00 0.25	-0.43 -0.71 -0.00

Sezione: 73
 Progressiva: 430.000
 Q. Progetto: 392.755

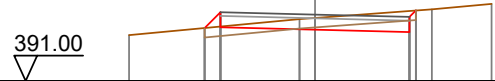

Quote Terreno	392.21		392.63	392.66	392.89	393.04
Quote Progetto		392.40	392.42	392.36	392.29	392.86
Parziali		0.42	2.50	2.50		
Progressiva		-2.92	-2.50	0.00	2.50	2.67
Dislivelli		0.00	0.38	-0.31	-0.56	0.00

Sezione: 74
 Progressiva: 440.000
 Q. Progetto: 394.083



Quote Terreno	393.73		394.10	394.25	394.45	
Quote Progetto		393.89	393.68	393.62	394.30	
Parziali		0.26	2.50	2.50	0.28	
Progressiva		-2.76	-2.50	0.00	2.50	2.78
Dislivelli		0.00	0.24	-0.41	-0.66	0.00

Sezione: 75
 Progressiva: 440.807
 Q. Progetto: 394.192

392.00

Quote Terreno	393.86	394.07	394.22	394.38	394.56
Quote Progetto		394.02 393.85	393.79	393.73 394.42	
Parziali		2.50	2.50	0.28	
Progressiva		-2.74 -2.50	0.00	2.50 2.79	
Dislivelli		0.00 0.22	-0.43	-0.67 0.00	

Sezione: 76
 Progressiva: 450.000
 Q. Progetto: 395.502

394.00

Quote Terreno	395.45	395.56	395.66	395.80	395.90
Quote Progetto		395.16	395.10	395.04 395.82	
Parziali		2.50	2.50	0.38	
Progressiva		-2.51	0.00	2.50 2.88	
Dislivelli		0.00	-0.58	-0.76 0.00	

Sezione: 77
 Progressiva: 460.000
 Q. Progetto: 396.860

395.00

Quote Terreno	397.17	397.21	397.28	397.30	397.45	397.45
Quote Progetto		397.22	396.52	396.46	396.40	397.38
Parziali		0.05	2.50	2.50	0.59	
Progressiva		-2.79	-2.50	0.00	2.50	3.09
Dislivelli		-0.00	-0.30	-0.82	-0.96	0.00

Sezione: 78
 Progressiva: 470.000
 Q. Progetto: 398.014

396.00

Quote Terreno	398.66	398.68	398.74		398.85	
Quote Progetto		398.68	397.61	397.55	398.81	
Parziali		0.60	2.50	2.50	0.85	
Progressiva		-3.10	-2.50	0.00	2.50	3.35
Dislivelli		0.00	-0.61	-1.13	-1.24	-0.00

Sezione: 79
 Progressiva: 472.195
 Q. Progetto: 398.240

396.00

Quote Terreno	398.97	398.97	399.03	399.03	399.08	
Quote Progetto		398.98	397.90	397.84	397.78	399.06
Parziali		0.68	2.50	2.50	0.88	
Progressiva		-3.18	-2.50	0.00	2.50	3.38
Dislivelli		0.00	-0.69	-1.19	-1.27	0.00

Sezione: 80
 Progressiva: 480.000
 Q. Progetto: 398.965

397.00

Quote Terreno	399.62	399.65	399.76	399.86	399.89	399.91
Quote Progetto		399.65	398.50	398.50	399.87	
Parziali		0.75	2.50	2.50	0.97	
Progressiva		-3.25	-2.50	0.00	2.50	3.47
Dislivelli		-0.00	-0.77	-1.19	-1.34	0.00

Sezione: 81
 Progressiva: 495.614
 Q. Progetto: 400.045

398.00

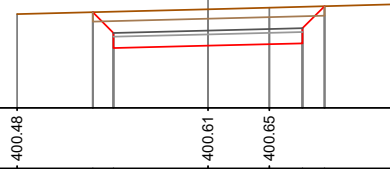

Quote Terreno	400.48		400.61	400.65	400.74
Quote Progetto		400.53 399.58	399.65	399.71 400.69	
Parziali		0.55	2.50	2.50	0.58
Progressiva		-3.05 -2.50	0.00	2.50 3.08	
Dislivelli		-0.00 -0.56	-0.96	-0.97 -0.00	

Sezione: 82
 Progressiva: 500.000
 Q. Progetto: 400.261

398.00

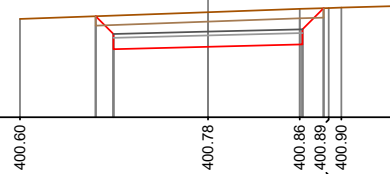

Quote Terreno	400.60		400.78	400.86 400.89 400.90	400.94
Quote Progetto		400.67 399.80	399.86	399.92 400.88	
Parziali		0.47	2.50	2.50	0.56
Progressiva		-2.97 -2.50	0.00	2.50 3.06	
Dislivelli		0.00 -0.49	-0.92	-0.94 -0.00	

Sezione: 83
 Progressiva: 500.316
 Q. Progetto: 400.275

398.00

Quote Terreno	400.61		400.78		400.90	400.91	400.96
Quote Progetto		400.68	399.81	399.87	399.94	400.89	
Parziali		0.46	2.50	2.50	0.56		
Progressiva		-2.96	-2.50	0.00	2.50	3.06	
Dislivelli		0.00	-0.48	-0.91	-0.94	0.00	

Sezione: 84
 Progressiva: 505.019
 Q. Progetto: 400.460

398.00

Quote Terreno	400.70		400.86		400.91		401.05
Quote Progetto		400.77	400.00	400.06	400.12	400.97	
Parziali		0.37	2.50	2.50	0.45		
Progressiva		-2.87	-2.50	0.00	2.50	2.95	
Dislivelli		-0.00	-0.38	-0.80	-0.83	0.00	

Sezione: 85
 Progressiva: 520.000
 Q. Progetto: 400.754

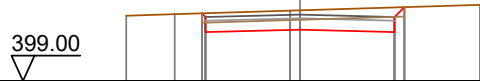

Quote Terreno	400.72	400.76	400.86	400.87	401.01
Quote Progetto		400.79 400.29	400.35	400.29 400.95	
Parziali			2.50	2.50	0.28
Progressiva		-2.59 -2.50	0.00	2.50 2.76	
Dislivelli		0.00 -0.10	-0.51	-0.65 -0.00	

Sezione: 86
 Progressiva: 525.946
 Q. Progetto: 400.746



Quote Terreno	400.66	400.78	400.80	400.93
Quote Progetto		400.73 400.41	400.35	400.28 400.87
Parziali			2.50	2.50
Progressiva		-2.58 -2.50	0.00	2.50 2.69
Dislivelli		-0.00 0.08	-0.46	-0.59 0.00

Sezione: 87
 Progressiva: 530.000
 Q. Progetto: 400.717

399.00

Quote Terreno	400.60		400.73		400.84	400.85
Quote Progetto		400.66 400.38	400.32		400.25 400.80	
Parziali			2.50		2.50	
Progressiva		-2.62 -2.50	0.00		2.50 2.65	
Dislivelli		0.00 0.12	-0.41		-0.54 -0.00	

Sezione: 88
 Progressiva: 531.221
 Q. Progetto: 400.708

399.00

Quote Terreno	400.59		400.71		400.74	400.80	400.83
Quote Progetto		400.64 400.37	400.31		400.25 400.78		
Parziali			2.50		2.50		
Progressiva		-2.63 -2.50	0.00		2.50 2.63		
Dislivelli		0.00 0.13	-0.40		-0.53 -0.00		

Sezione: 89
 Progressiva: 536.497
 Q. Progetto: 400.669



Quote Terreno	400.54	400.58	400.66	400.68	400.75	400.76
Quote Progetto		400.50 400.33	400.27		400.21 400.72	
Parziali			2.50	2.50		
Progressiva		-2.65 -2.50	0.00		2.50 2.61	
Dislivelli		-0.00 0.14	-0.39		-0.51 0.00	

Sezione: 90
 Progressiva: 540.000
 Q. Progetto: 400.644



Quote Terreno	400.52	400.54	400.57	400.60	400.62	400.72
Quote Progetto			400.18		400.24	400.18 400.67
Parziali			2.50	2.50		
Progressiva			-2.52	0.00		2.50 2.59
Dislivelli			-0.00	-0.38		-0.49 0.00

Sezione: 91
 Progressiva: 544.664
 Q. Progetto: 400.611



Quote Terreno	400.53	400.54	400.59	400.60	400.66
Quote Progetto		400.15	400.21	400.27	400.64
Parziali			2.50	2.50	
Progressiva		-2.52	0.00	2.50	2.54
Dislivelli		-0.00	-0.39	-0.36	-0.00

Sezione: 92
 Progressiva: 550.000
 Q. Progetto: 400.610



Quote Terreno	400.53	400.61	400.63	400.67	
Quote Progetto		400.15	400.21	400.27	400.65
Parziali			2.50	2.50	
Progressiva		-2.52	0.00	2.50	2.53
Dislivelli		0.00	-0.40	-0.37	0.00

Sezione: 93
 Progressiva: 560.000
 Q. Progetto: 400.763

399.00

Quote Terreno	400.67	400.72	400.74	400.76	400.76
Quote Progetto		400.30	400.36	400.43	400.76
Parziali		2.50	2.50		
Progressiva		-2.51	0.00	2.50	2.57
Dislivelli		-0.00	-0.38	-0.33	-0.00

Sezione: 94
 Progressiva: 564.798
 Q. Progetto: 400.908

399.00

Quote Terreno	400.78	400.86	400.87	400.91
Quote Progetto		400.81	400.51	400.57
Parziali		2.50	2.50	
Progressiva		-2.53	0.00	2.50
Dislivelli		0.00	-0.35	-0.32

Sezione: 95
 Progressiva: 570.000
 Q. Progetto: 401.116

399.00

Quote Terreno	400.96	401.00	401.08	401.08	401.13	401.16
Quote Progetto		401.02	400.65	400.72	400.78	401.12
Parziali		2.50	2.50			
Progressiva		-2.53	-2.50	0.00	2.50	2.56
Dislivelli		0.00	0.03	-0.37	-0.34	0.00

Sezione: 96
 Progressiva: 580.000
 Q. Progetto: 401.597

400.00

Quote Terreno	401.37	401.44	401.62	401.66	401.80	401.85
Quote Progetto		401.49	401.13	401.20	401.26	401.74
Parziali		2.50	2.50			
Progressiva		-2.54	-2.50	0.00	2.50	2.58
Dislivelli		0.00	0.04	-0.43	-0.48	0.00

Sezione: 97
 Progressiva: 584.933
 Q. Progetto: 401.835

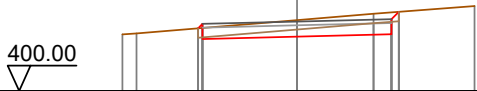

Quote Terreno	401.49	401.52		401.87	402.04	402.24	
Quote Progetto			401.66	401.37	401.43	401.50	402.09
Parziali				2.50		2.50	
Progressiva			-2.62	-2.50	0.00	2.50	2.69
Dislivelli			-0.00	0.11	-0.44	-0.58	0.00

Sezione: 98
 Progressiva: 597.830
 Q. Progetto: 402.423

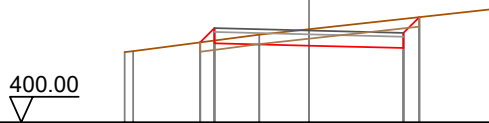

Quote Terreno	401.85	401.88		402.31	402.46	403.00	
Quote Progetto			402.11	402.09	402.02	401.96	402.78
Parziali			0.33	2.50		2.50	0.42
Progressiva			-2.88	-2.50	0.00	2.50	2.92
Dislivelli			0.00	0.33	-0.43	-0.77	0.00

Sezione: 99
 Progressiva: 600.000
 Q. Progetto: 402.497

400.00

Quote Terreno	401.87	401.97		402.50	402.81	403.08
Quote Progetto			402.11 402.16	402.10	402.03 402.87	
Parziali			0.45	2.50	2.50	0.43
Progressiva			-2.95 -2.50	0.00	2.50 2.93	
Dislivelli			0.00 0.39	-0.40	-0.79 0.00	

Sezione: 100
 Progressiva: 605.550
 Q. Progetto: 402.650

400.00

Quote Terreno	401.91	402.10	402.21	402.33	402.60	403.24
Quote Progetto			402.19 402.31		402.25	402.19 402.98
Parziali			0.52	2.50	2.50	0.39
Progressiva			-3.02 -2.50	0.00	2.50 2.89	
Dislivelli			0.00 0.44	-0.35	-0.74 0.00	

Sezione: 101
 Progressiva: 610.000
 Q. Progetto: 402.763

400.00

Quote Terreno	-401.98	-402.36	-402.73	-403.19	-403.42
Quote Progetto		-402.28 -402.43	-402.36	-402.30 -403.16	
Parziali		0.55	2.50	2.50	0.46
Progressiva		-3.05 -2.50	0.00	2.50 2.96	
Dislivelli		0.00 0.46	-0.36	-0.79 0.00	

Sezione: 102
 Progressiva: 613.271
 Q. Progetto: 402.848

401.00

Quote Terreno	-402.09	-402.47	-402.83	-403.54	
Quote Progetto		-402.39 -402.51	-402.45	-402.39 -403.26	
Parziali		0.52	2.50	2.50	0.47
Progressiva		-3.02 -2.50	0.00	2.50 2.97	
Dislivelli		0.00 0.44	-0.38	-0.80 -0.00	

Sezione: 103
 Progressiva: 620.000
 Q. Progetto: 403.077

401.00

Quote Terreno	402.34	402.67	403.09	403.53	403.86
Quote Progetto		402.64 402.61	402.68	402.61 403.57	
Parziali		0.38	2.50	2.50	0.56
Progressiva		-2.88 -2.50	0.00	2.50 3.06	
Dislivelli		0.00 0.32	-0.42	-0.87 0.00	

Sezione: 104
 Progressiva: 640.000
 Q. Progetto: 403.800

401.00

Quote Terreno	402.97	403.26	403.82	404.21	404.69
Quote Progetto		403.31 403.34	403.40	403.34 404.35	
Parziali		0.43	2.50	2.50	0.61
Progressiva		-2.93 -2.50	0.00	2.50 3.11	
Dislivelli		0.00 0.36	-0.42	-0.91 -0.00	

Sezione: 105
 Progressiva: 659.200
 Q. Progetto: 404.654

402.00

Quote Terreno	403.91	404.09	404.71	404.86	405.55
Quote Progetto		404.24 404.19	404.25	404.32 405.21	
Parziali		0.35	2.50	2.50	0.49
Progressiva		2.86 2.50	0.00	2.50 2.99	
Dislivelli		-0.00 -0.30	-0.45	-0.81 -0.00	

Sezione: 106
 Progressiva: 660.000
 Q. Progetto: 404.692

402.00

Quote Terreno	403.95	404.13	404.75	405.04	405.60
Quote Progetto		404.28 404.23	404.29	404.35 405.25	
Parziali		0.35	2.50	2.50	0.50
Progressiva		2.85 2.50	0.00	2.50 3.00	
Dislivelli		-0.00 -0.29	-0.46	-0.81 -0.00	

Sezione: 107
 Progressiva: 662.515
 Q. Progetto: 404.811

403.00

Quote Terreno	404.06	404.25	404.88	405.63	405.72
Quote Progetto		404.40 404.38	404.41	404.47 405.38	
Parziali		0.35	2.50	2.50	0.51
Progressiva		2.85 2.50	0.00	2.50 3.01	
Dislivelli		-0.00 -0.29	-0.47	-0.82 -0.00	

Sezione: 108
 Progressiva: 665.831
 Q. Progetto: 404.967

403.00

Quote Terreno	404.20	404.28	404.42	404.60	405.01	405.86
Quote Progetto			404.53 404.50	404.57	404.63 405.52	
Parziali			0.38	2.50	2.50	0.49
Progressiva			2.88 2.50	0.00	2.50 2.99	
Dislivelli			0.00 -0.32	-0.44	-0.81 -0.00	

Sezione: 109
 Progressiva: 680.000
 Q. Progetto: 405.634

403.00

Quote Terreno	404.88	405.32	405.62	406.21	406.39
Quote Progetto		405.18 405.17	405.23	405.17 406.08	
Parziali		0.39	2.50	2.50	0.50
Progressiva		-2.88 -2.50	0.00	2.50 3.00	
Dislivelli		0.00 0.33	-0.39	-0.83 0.00	

Sezione: 110
 Progressiva: 695.157
 Q. Progetto: 406.336

404.00

Quote Terreno	405.69	406.32	406.36	407.08
Quote Progetto		405.98 405.87	405.94	406.00 406.79
Parziali		0.30	2.50	2.50
Progressiva		-2.80 -2.50	0.00	2.50 2.89
Dislivelli		0.00 0.25	-0.44	-0.74 0.00

Sezione: 111
 Progressiva: 700.000
 Q. Progetto: 406.506

404.00

Quote Terreno	405.86		406.57		407.19
Quote Progetto		406.16	406.11	406.17	407.00
Parziali		0.28	2.50	2.50	0.43
Progressiva		-2.79	0.00	2.50	2.93
Dislivelli		0.00	-0.46	-0.76	-0.00

Sezione: 112
 Progressiva: 702.027
 Q. Progetto: 406.563

404.00

Quote Terreno	405.92		406.62		407.34
Quote Progetto		406.21	406.16	406.23	407.06
Parziali		0.28	2.50	2.50	0.43
Progressiva		-2.79	0.00	2.50	2.93
Dislivelli		0.00	-0.46	-0.77	0.00

Sezione: 113
 Progressiva: 708.898
 Q. Progetto: 406.696

405.00

Quote Terreno	406.04		406.74		407.20	407.46
Quote Progetto		406.33 406.23	406.30		406.36 407.17	
Parziali		0.30	2.50	2.50	0.41	
Progressiva		-2.80 -2.50	0.00		2.50 2.91	
Dislivelli		0.00 0.26	-0.44		-0.75 0.00	

Sezione: 114
 Progressiva: 720.000
 Q. Progetto: 406.843

405.00

Quote Terreno	406.15		406.84		407.14	407.55
Quote Progetto		406.44 406.38	406.44		406.38 407.27	
Parziali		0.34	2.50	2.50	0.49	
Progressiva		-2.84 -2.50	0.00		2.50 2.99	
Dislivelli		0.00 0.29	-0.40		-0.82 -0.00	

Sezione: 115
 Progressiva: 740.000
 Q. Progetto: 407.100

405.00

Quote Terreno	406.47		407.11		407.75	407.77
Quote Progetto		406.74	406.64	406.70	406.64	407.50
Parziali		0.30	2.50	2.50	0.47	
Progressiva		-2.80	-2.50	0.00	2.50	2.97
Dislivelli		0.00	0.26	-0.41	-0.81	0.00

Sezione: 116
 Progressiva: 760.000
 Q. Progetto: 407.086

405.00

Quote Terreno	406.88		407.44		407.68	408.06
Quote Progetto		407.12	406.62	406.69	406.62	407.83
Parziali			2.50	2.50	0.80	
Progressiva		-2.60	-2.50	0.00	2.50	3.30
Dislivelli		0.00	-0.11	-0.75	-1.11	-0.00

Sezione: 117
 Progressiva: 778.632
 Q. Progetto: 406.939

405.00

Quote Terreno	407.21	407.23		407.62	407.76		408.20	408.40
Quote Progetto			407.43	406.60	406.54	406.48	408.19	
Parziali			0.43	2.50	2.50	1.31		
Progressiva			-2.93	-2.50	0.00	2.50	3.81	
Dislivelli			-0.00	-0.48	-1.22	-1.57	-0.00	

Sezione: 118
 Progressiva: 780.000
 Q. Progetto: 406.906

405.00

Quote Terreno	407.24		407.63	407.71	407.79	407.84		408.42
Quote Progetto			407.46	406.57	406.51	406.44	408.20	
Parziali			0.49	2.50	2.50	1.36		
Progressiva			-2.99	-2.50	0.00	2.50	3.86	
Dislivelli			-0.00	-0.55	-1.29	-1.62	0.00	

Sezione: 119
 Progressiva: 787.774
 Q. Progetto: 406.662

▽ 405.00

Quote Terreno	407.49	407.54		408.02	408.16	408.62
Quote Progetto		407.69	406.32	406.26	406.20	408.43
Parziali		0.96	2.50	2.50	1.83	
Progressiva		-3.46	-2.50	0.00	2.50	4.33
Dislivelli		0.00	-1.05	-1.76	-2.06	0.00

Sezione: 120
 Progressiva: 790.000
 Q. Progetto: 406.589

▽ 405.00

Quote Terreno	407.58		408.11	408.28	408.42	408.70
Quote Progetto		407.77	406.25	406.19	406.13	408.52
Parziali		1.11	2.50	2.50	2.00	
Progressiva		-3.61	-2.50	0.00	2.50	4.50
Dislivelli		0.00	-1.22	-1.92	-2.22	0.00

Sezione: 121
 Progressiva: 796.915
 Q. Progetto: 406.309

404.00

Quote Terreno	407.77		408.14	408.24	408.45	408.76	408.82
Quote Progetto		407.92	405.97	405.91	405.85	408.67	
Parziali		1.55	2.50	2.50	2.42		
Progressiva		-4.05	-2.50	0.00	2.50	4.92	
Dislivelli		0.00	-1.67	-2.34	-2.62	-0.00	

Sezione: 122
 Progressiva: 798.528
 Q. Progetto: 406.231

404.00

Quote Terreno	407.82		408.29	408.32	408.49	408.66	408.82
Quote Progetto		407.97	405.89	405.83	405.77	408.70	
Parziali		1.68	2.50	2.50	2.53		
Progressiva		-4.18	-2.50	0.00	2.50	5.03	
Dislivelli		-0.00	-1.81	-2.46	-2.73	0.00	

Sezione: 123
 Progressiva: 800.000
 Q. Progetto: 406.154

404.00

Quote Terreno	407.88			408.34	408.48	408.58		408.83
Quote Progetto		408.02	405.82	405.75	405.69		408.71	
Parziali		1.81	2.50	2.50	2.62			
Progressiva		-4.31	-2.50	0.00	2.50		5.12	
Dislivelli		0.00	-1.94	-2.59	-2.84		0.00	

Sezione: 124
 Progressiva: 810.000
 Q. Progetto: 405.518

404.00

Quote Terreno	407.96			408.34	408.41	408.48		408.69
Quote Progetto		408.07	405.18	405.12	405.06		408.61	
Parziali		2.49	2.50	2.50	3.16			
Progressiva		-4.99	-2.50	0.00	2.50		5.66	
Dislivelli		0.00	-2.63	-3.22	-3.43		0.00	

Sezione: 125
 Progressiva: 820.000
 Q. Progetto: 404.681

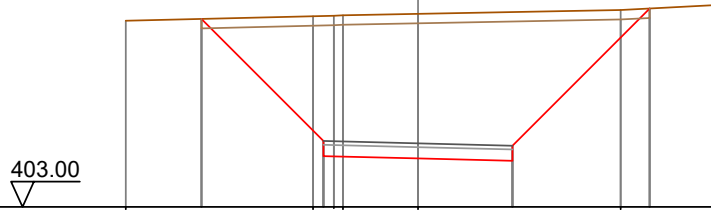

Quote Terreno	407.92	408.04	408.07	408.11	408.21	408.35
Quote Progetto	407.97	404.34	404.28	404.22	408.25	
Parziali		3.23	2.50	2.50	3.63	
Progressiva		-5.73	-2.50	0.00	2.50	6.13
Dislivelli		0.00	-3.31	-3.83	-3.93	0.00

Sezione: 126
 Progressiva: 823.546
 Q. Progetto: 404.336

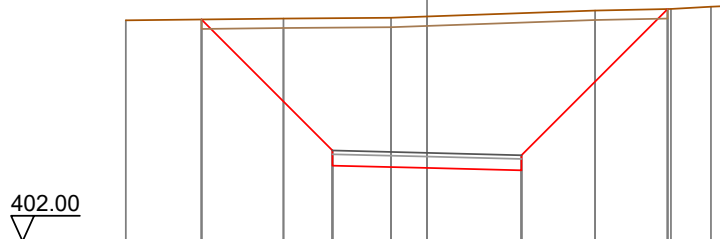

Quote Terreno	407.84	407.89	407.91	407.94	408.10	408.14	408.20	408.24
Quote Progetto	407.86	404.00	403.94	403.87	408.14			
Parziali		3.46	2.50	2.50	3.86			
Progressiva		-5.96	-2.50	0.00	2.50	6.36		
Dislivelli		-0.00	-3.50	-4.01	-4.16	0.00		

Sezione: 127
 Progressiva: 830.000
 Q. Progetto: 403.681

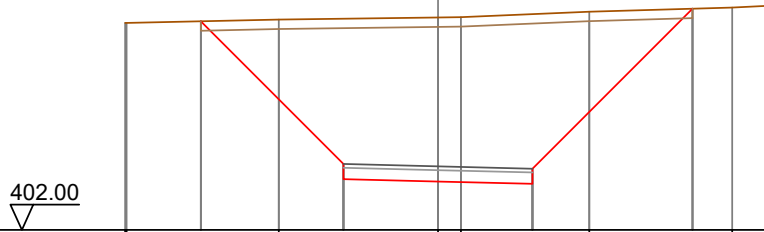

Quote Terreno	407.47 407.48	407.56	403.34	403.28 407.63	407.77	407.88 407.93
Quote Progetto		407.52	403.34	403.28 403.22		407.85
Parziali		3.77	2.50	2.50	4.23	
Progressiva		-6.27	-2.50	0.00	2.50	6.73
Dislivelli		0.00	-3.84	-4.34	-4.49	0.00

Sezione: 128
 Progressiva: 840.000
 Q. Progetto: 402.744

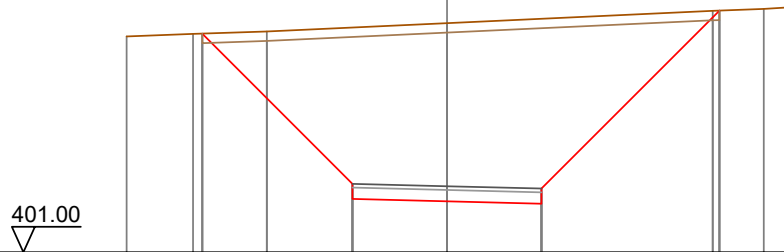

Quote Terreno	406.71	406.77 406.83	402.05	407.05	407.38 407.43 407.48	
Quote Progetto		406.78	402.41	402.34 402.28	407.39	
Parziali		3.97	2.50	2.50	4.71	
Progressiva		-6.47	-2.50	0.00	2.50	7.21
Dislivelli		0.00	-4.13	-4.71	-4.89	-0.00

Sezione: 129
 Progressiva: 848.565
 Q. Progetto: 402.101

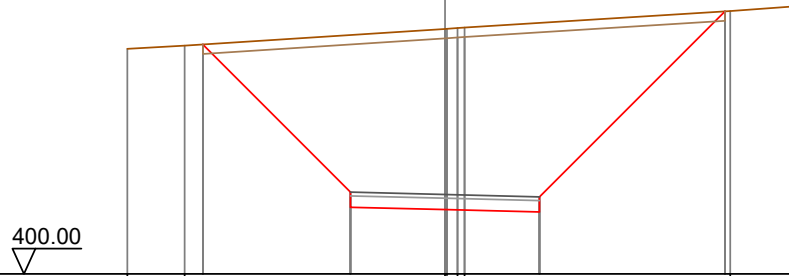

Quote Terreno		405.95	406.04		406.48 406.50 406.51		406.95	407.09
Quote Progetto			406.07		401.76		401.64	406.94
Parziali				3.90	2.50	2.50	4.90	
Progressiva			-6.40		-2.50	0.00	2.50	7.40
Dislivelli			0.00		-4.15	-4.78	-5.00	0.00

Sezione: 130
 Progressiva: 855.402
 Q. Progetto: 401.693

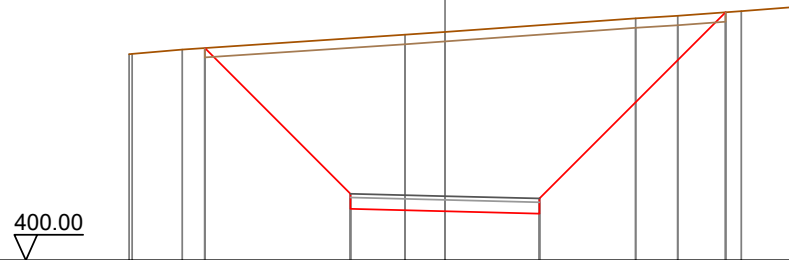

Quote Terreno		405.45 405.45	405.57		405.96 406.04		406.39 406.46	406.59 406.71
Quote Progetto			405.61		401.36		401.23	406.55
Parziali				3.85	2.50	2.50	4.92	
Progressiva			-6.35		-2.50	0.00	2.50	7.42
Dislivelli			-0.00		-4.11	-4.74	-4.98	0.00

Sezione: 131
 Progressiva: 859.022
 Q. Progetto: 401.516

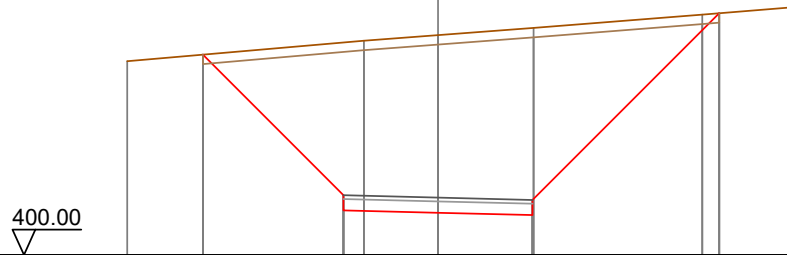

Quote Terreno		405.12		405.66	405.81	406.00		406.35	406.56
Quote Progetto		405.30		401.18	401.12	401.05		406.39	
Parziali			3.72	2.50	2.50		4.94		
Progressiva		-6.22		-2.50	0.00	2.50		7.44	
Dislivelli		-0.00		-4.04	-4.70	-4.95		0.00	

Sezione: 132
 Progressiva: 860.000
 Q. Progetto: 401.472

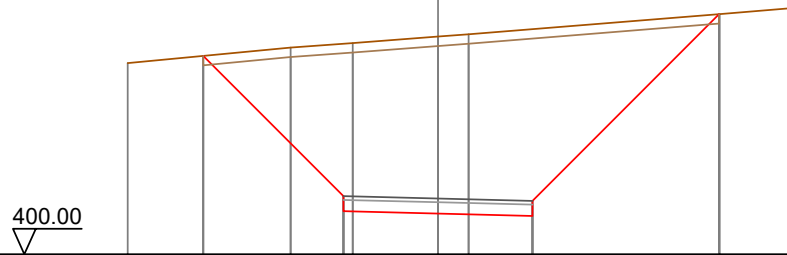

Quote Terreno		405.05		405.46	405.58	405.75	405.82		406.35	406.51
Quote Progetto		405.24		401.13	401.07	401.01		406.35		
Parziali			3.71	2.50	2.50		4.94			
Progressiva		-6.21		-2.50	0.00	2.50		7.44		
Dislivelli		0.00		-4.03	-4.68	-4.94		0.00		

Sezione: 133
 Progressiva: 862.641
 Q. Progetto: 401.364

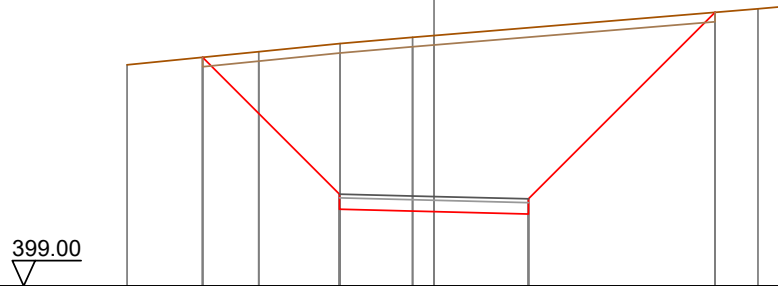

Quote Terreno	404.85	405.19	405.41	405.57	405.62	406.33	406.40
Quote Progetto		405.05	401.03	400.96	400.90	406.24	
Parziali		3.62	2.50	2.50	4.93		
Progressiva		-6.12	-2.50	0.00	2.50	7.43	
Dislivelli		0.00	-3.98	-4.66	-4.93	0.00	

Sezione: 134
 Progressiva: 876.211
 Q. Progetto: 401.030

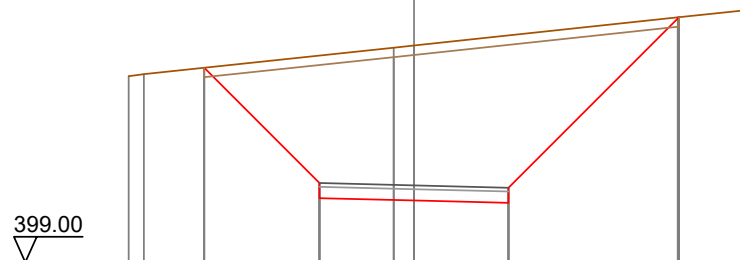

Quote Terreno	403.92	403.97	404.67	404.73	405.48	405.69
Quote Progetto		404.14	400.69	400.63	400.57	405.48
Parziali		3.05	2.50	2.50	4.51	
Progressiva		-5.55	-2.50	0.00	2.50	7.01
Dislivelli		0.00	-3.37	-4.10	-4.43	0.00

Sezione: 135
 Progressiva: 880.000
 Q. Progetto: 401.003

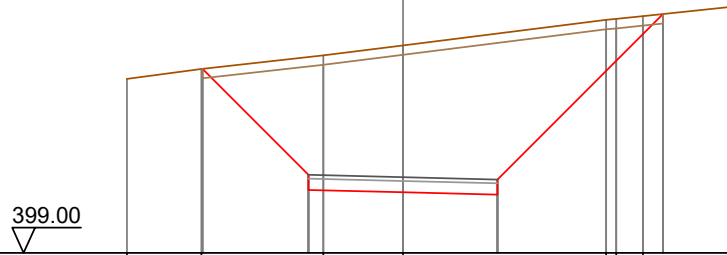

Quote Terreno	403.60	403.86	404.22	404.49		405.16	405.19	405.26	405.53
Quote Progetto		403.87	400.67	400.60	400.54			405.32	
Parziali			2.80	2.50	2.50		4.38		
Progressiva		-5.30	-2.50	0.00	2.50			6.88	
Dislivelli		0.00	-3.11	-3.89	-4.26			0.00	

Sezione: 136
 Progressiva: 881.987
 Q. Progetto: 401.000

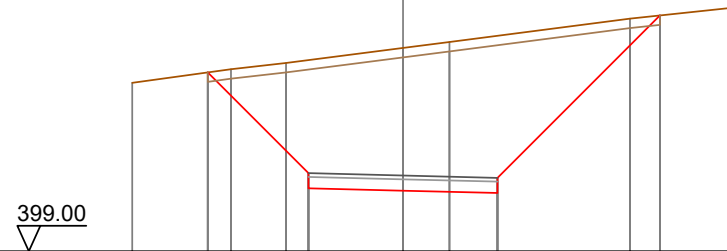

Quote Terreno	403.45	403.81	403.98	404.37	404.53		405.15	405.44
Quote Progetto		403.73	400.66	400.60	400.54		405.23	
Parziali			2.66	2.50	2.50		4.30	
Progressiva		-5.16	-2.50	0.00	2.50			6.80
Dislivelli		0.00	-2.99	-3.77	-4.16			0.00

SEZIONI TRASVERSALI

Profilo longitudinale tratto 7-8

Viabilità di accesso impianto 4-5

Nota: Le canalette di deflusso delle acque meteoriche, non indicate nel presente elaborato, sono rappresentate graficamente nelle sezioni stradali tipo dell'elaborato "SR-VI-TC12_Piazzole aerogeneratori e strade di servizio - Particolari costruttivi", individuate planimetricamente nell'elaborato "SR-VI-TC13_Opere di regimazione acque superficiali - Planimetria generale" e quantificate nell'elaborato "SR-VI-RC6_Computo Metrico Estimativo opere civili".

DISEGNI DI RIFERIMENTO

TAVOLA	DESCRIZIONE
SR-VI-TC8.1	Piazzole e viabilità - Planimetria di progetto - Fase di cantiere
SR-VI-TC10	Profili longitudinali viabilità di impianto
SR-VI-TC12	Piazzole aerogeneratori e strade di servizio - Particolari costruttivi
SR-VI-TC13	Opere di regimazione acque superficiali - Planimetria generale

Sezione: 4
 Progressiva: 20.000
 Q. Progetto: 465.862

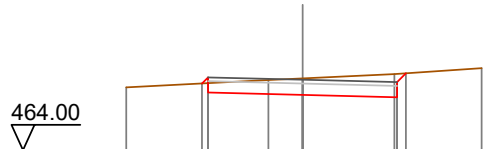

Quote Terreno	465.66		465.85	465.90	466.01	466.17
Quote Progetto		465.76	465.52	465.46	465.40	466.03
Parziali			2.50		2.50	
Progressiva		-2.66	-2.50	0.00	2.50	2.73
Dislivelli		-0.00	0.15	-0.43	-0.62	0.00

Sezione: 5
 Progressiva: 29.843
 Q. Progetto: 465.496

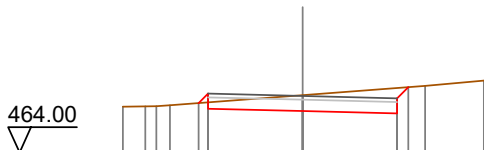

Quote Terreno	465.21	465.22	465.25		465.52		465.76	465.90
Quote Progetto				465.31	465.16	465.10	465.03	465.73
Parziali					2.50		2.50	0.28
Progressiva				-2.75	-2.50	0.00	2.50	2.79
Dislivelli				0.00	0.23	-0.42	-0.67	0.00

Sezione: 6
 Progressiva: 40.000
 Q. Progetto: 465.260

463.00

Quote Terreno	465.03	465.05	465.29	465.32	465.48	465.65
Quote Progetto		465.13 464.92	464.86	464.86	464.80 465.46	
Parziali			2.50	2.50	0.28	
Progressiva		-2.69 -2.50	0.00	0.00	2.50 2.76	
Dislivelli		0.00 0.18	-0.46		-0.65 0.00	

Sezione: 7
 Progressiva: 50.000
 Q. Progetto: 465.054

463.00

Quote Terreno	464.96	465.00	465.01	465.01	465.06	465.22	465.45
Quote Progetto		464.99 464.72	464.85	464.85	464.59 465.21		
Parziali			2.50	2.50			
Progressiva		-2.63 -2.50	0.00	0.00	2.50 2.72		
Dislivelli		0.00 0.13	-0.36		-0.60 -0.00		

Sezione: 8
 Progressiva: 50.778
 Q. Progetto: 465.038

463.00

Quote Terreno	464.93	464.96	465.00	465.01	465.05	465.21	465.45
Quote Progetto		464.96 464.70	464.64	464.64	464.58 465.21		
Parziali			2.50	2.50			
Progressiva		-2.64 -2.50	0.00	0.00	2.50 2.74		
Dislivelli		0.00 0.14	-0.36		-0.61 0.00		

Sezione: 9
 Progressiva: 60.000
 Q. Progetto: 464.843

463.00

Quote Terreno	464.73	464.81	464.91	464.91	465.09
Quote Progetto		464.81 464.38	464.44	464.44	464.38 465.01
Parziali			2.50	2.50	
Progressiva		-2.53 -2.50	0.00	0.00	2.50 2.73
Dislivelli		0.00 -0.03	-0.47		-0.62 0.00

Sezione: 10
 Progressiva: 78.423
 Q. Progetto: 464.079

462.00

Quote Terreno	463.75		463.93	463.96	464.37
Quote Progetto		463.83	463.74	463.68	463.62
Parziali		0.31	2.50	2.50	0.31
Progressiva		-2.81	-2.50	0.00	2.50
Dislivelli		0.00	0.30	-0.29	-0.56

Sezione: 11
 Progressiva: 80.000
 Q. Progetto: 464.001

462.00

Quote Terreno	463.63		463.81	463.88	464.27
Quote Progetto		463.72	463.66	463.60	463.54
Parziali		0.34	2.50	2.50	0.34
Progressiva		-2.84	-2.50	0.00	2.50
Dislivelli		0.00	0.33	-0.28	-0.55

Sezione: 12
 Progressiva: 86.375
 Q. Progetto: 463.686

462.00

Quote Terreno	463.18	463.23	463.27	463.30		463.62	464.07
Quote Progetto		463.34	463.35		463.29	463.22	463.86
Parziali		0.40		2.50	2.50		0.36
Progressiva		-2.90	-2.50		0.00	2.50	2.75
Dislivelli		0.00	0.37		-0.33	-0.63	0.00

Sezione: 13
 Progressiva: 90.000
 Q. Progetto: 463.507

461.00

Quote Terreno	462.98		463.16	463.46		463.85	464.01
Quote Progetto		463.13	463.17	463.11		463.04	463.81
Parziali		0.44		2.50	2.50	0.36	
Progressiva		-2.94	-2.50	0.00		2.50	2.86
Dislivelli		0.00	0.41		-0.36	-0.72	0.00

Sezione: 14
 Progressiva: 94.328
 Q. Progetto: 463.294

461.00

Quote Terreno	462.73	462.91	463.03	463.23	463.84
Quote Progetto		462.93 462.96		462.89 463.23	462.83 463.59
Parziali		0.43	2.50	2.50	0.36 0.00
Progressiva		-2.93 -2.50		0.00	2.50 2.86
Dislivelli		0.00 0.40		-0.34	-0.71 -0.00

Sezione: 15
 Progressiva: 100.000
 Q. Progetto: 463.013

461.00

Quote Terreno	462.36 462.37		462.88	462.98	463.49 463.61
Quote Progetto		462.61 462.55		462.61 463.34	462.55 463.34
Parziali		0.34	2.50	2.50	0.39 0.00
Progressiva		-2.84 -2.50		0.00	2.50 2.89
Dislivelli		0.00 0.29		-0.36	-0.74 0.00

Sezione: 16
 Progressiva: 116.262
 Q. Progetto: 461.952

460.00

Quote Terreno	461.34 461.38		461.97	462.20	462.62
Quote Progetto		461.59 461.61	461.55 461.97	461.49 462.35	
Parziali		0.42	2.50	2.50	0.46 0.00
Progressiva		-2.92 -2.50	0.00	2.50 2.96	
Dislivelli		0.00 0.37	-0.41	-0.80 -0.00	

Sezione: 17
 Progressiva: 120.000
 Q. Progetto: 461.680

459.00

Quote Terreno	460.99	461.15	461.64	461.94	462.32
Quote Progetto		461.24 461.34	461.28 461.64	461.22 462.04	
Parziali		0.50	2.50	2.50	0.42 0.00
Progressiva		-3.00 -2.50	0.00	2.50 2.92	
Dislivelli		-0.00 0.44	-0.36	-0.76 0.00	

Sezione: 18
 Progressiva: 124.509
 Q. Progetto: 461.352

459.00

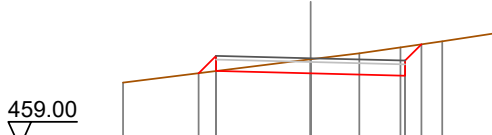

Quote Terreno	460.70			461.32	461.48	461.64	461.80	462.02
Quote Progetto		460.95	461.01	460.95	461.32	460.89	461.72	
Parziali		0.46	2.50		2.50	0.43		
Progressiva		-2.96	-2.50	0.00		2.50	2.93	
Dislivelli		-0.00	0.40	-0.37		-0.77	0.00	

Sezione: 19
 Progressiva: 130.000
 Q. Progetto: 460.966

459.00

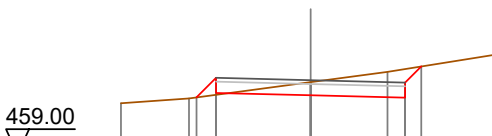

Quote Terreno	460.36	460.48		460.91	461.19	461.65
Quote Progetto		460.51	460.63	460.57	460.50	461.33
Parziali		0.52	2.50		2.50	0.42
Progressiva		-3.02	-2.50	0.00	2.50	2.92
Dislivelli		0.00	0.45	-0.35		-0.76
						0.00

Sezione: 20
 Progressiva: 132.757
 Q. Progetto: 460.793

459.00

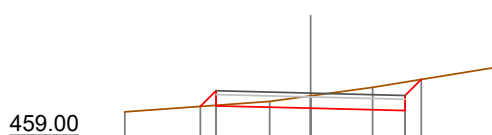

Quote Terreno	460.30			460.57	460.72	460.95	461.48
Quote Progetto		460.44	460.46	460.39	460.39	460.33	461.15
Parziali		0.42	2.50		2.50	0.42	
Progressiva		-2.92	-2.50	0.00		2.50	2.92
Dislivelli		0.00	0.39	-0.33		-0.76	0.00

Sezione: 21
 Progressiva: 140.000
 Q. Progetto: 460.412

458.00

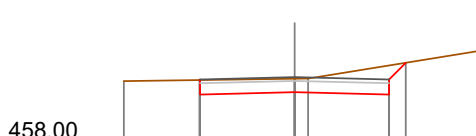

Quote Terreno	460.30			460.37	460.37	461.11
Quote Progetto		459.95		460.01	460.01	459.95
Parziali			2.50		2.50	0.44
Progressiva		-2.52		0.00		2.50
Dislivelli		0.00		-0.36		-0.77
						0.00

Sezione: 22
 Progressiva: 160.000
 Q. Progetto: 459.886

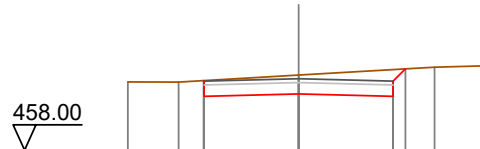

Quote Terreno	459.80	459.80	459.99	460.20	460.23
Quote Progetto		459.42	459.49	459.42	460.15
Parziali		2.50	2.50	0.33	
Progressiva		-2.51	0.00	2.50	2.83
Dislivelli		-0.00	-0.50	-0.71	0.00

Sezione: 23
 Progressiva: 167.345
 Q. Progetto: 459.782

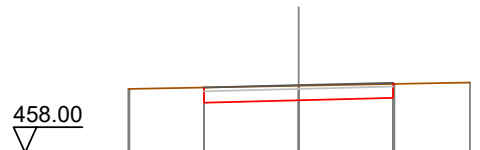

Quote Terreno	459.68	459.68	459.76		459.85
Quote Progetto		459.32	459.38	459.44	459.81
Parziali		2.50	2.50		
Progressiva		-2.50	0.00	2.50	2.53
Dislivelli		0.00	-0.38	-0.37	-0.00

Sezione: 24
 Progressiva: 168.826
 Q. Progetto: 459.761

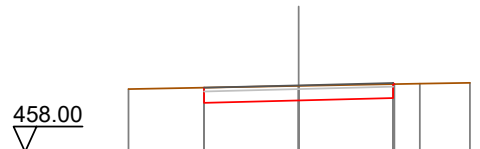

Quote Terreno	459.66	459.30	459.74	459.80	459.83
Quote Progetto		459.36	459.42	459.79	
Parziali		2.50	2.50		
Progressiva		-2.50	0.00	2.50	2.53
Dislivelli		-0.00	-0.38	-0.37	0.00

Sezione: 25
 Progressiva: 170.000
 Q. Progetto: 459.744



Quote Terreno	459.65	459.73	459.76	459.76	459.80
Quote Progetto		459.28	459.34	459.41	459.77
Parziali		2.50	2.50		
Progressiva		-2.50	0.00	2.50	2.53
Dislivelli		0.00	-0.38	-0.36	0.00

Sezione: 26
 Progressiva: 170.307
 Q. Progetto: 459.740

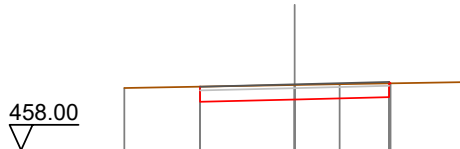

Quote Terreno	459.64		459.72	459.75	459.80
Quote Progetto		459.28	459.34	459.40	459.77
Parziali		2.50	2.50		
Progressiva		-2.50	0.00	2.50	2.94
Dislivelli		0.00	-0.38	-0.36	0.00

Sezione: 27
 Progressiva: 180.000
 Q. Progetto: 459.634

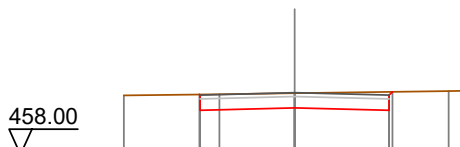

Quote Terreno	459.57		459.62	459.68	459.69
Quote Progetto		459.17	459.23	459.17	459.66
Parziali		2.50	2.50		
Progressiva		-2.52	0.00	2.50	2.59
Dislivelli		0.00	-0.39	-0.48	0.00

Sezione: 28
 Progressiva: 200.000
 Q. Progetto: 459.744

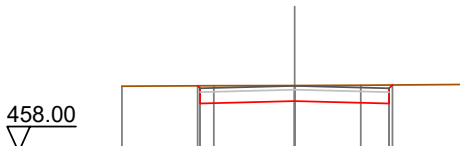

Quote Terreno	459.74		459.76	459.76	459.78
Quote Progetto		459.75	459.34	459.28	459.77
Parziali		2.50	2.50		
Progressiva		-2.57	0.00	2.50	2.59
Dislivelli		0.00	-0.41	-0.49	0.00

Sezione: 29
 Progressiva: 204.441
 Q. Progetto: 459.774

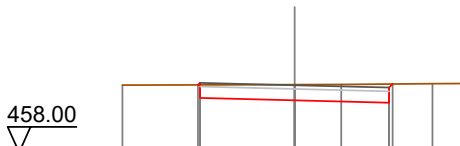

Quote Terreno	459.78		459.79	459.79	459.81	459.82
Quote Progetto		459.78	459.37	459.31	459.81	
Parziali		2.50	2.50			
Progressiva		-2.55	0.00	2.50	2.59	
Dislivelli		0.00	-0.42	-0.49	0.00	

Sezione: 30
 Progressiva: 207.378
 Q. Progetto: 459.794

458.00



Quote Terreno	459.80		459.81	459.82	459.82	459.83
Quote Progetto		459.81 459.46		459.39		459.33 459.82
Parziali		2.50		2.50		
Progressiva		-2.55 -2.50		0.00		2.50 2.59
Dislivelli		0.00 0.05		-0.42		-0.49 0.00

Sezione: 31
 Progressiva: 210.000
 Q. Progetto: 459.812

458.00

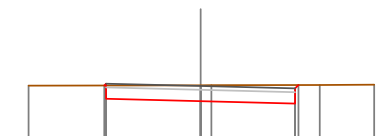

Quote Terreno	459.82		459.83	459.83	459.84	459.85
Quote Progetto		459.83 459.47		459.41		459.35 459.84
Parziali		2.50		2.50		
Progressiva		-2.55 -2.50		0.00		2.50 2.59
Dislivelli		0.00 0.05		-0.42		-0.49 0.00

Sezione: 32
 Progressiva: 210.315
 Q. Progetto: 459.814

458.00

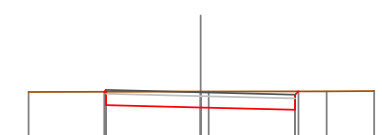

Quote Terreno	459.82		459.83	459.83	459.84	459.85
Quote Progetto		459.83 459.48		459.41		459.35 459.84
Parziali		2.50		2.50		
Progressiva		-2.55 -2.50		0.00		2.50 2.59
Dislivelli		0.00 0.05		-0.42		-0.49 0.00

Sezione: 33
 Progressiva: 220.000
 Q. Progetto: 459.879

458.00

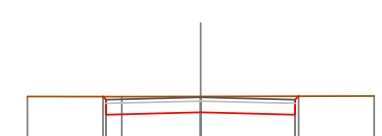

Quote Terreno	459.90		459.90	459.90		459.91
Quote Progetto		459.90 459.42		459.48		459.42 459.91
Parziali		2.50		2.50		
Progressiva		-2.58 -2.50		0.00		2.50 2.59
Dislivelli		0.00 -0.08		-0.42		-0.49 0.00

Sezione: 34
 Progressiva: 234.455
 Q. Progetto: 459.976

458.00

Quote Terreno	459.98	459.99	459.98	459.98
Quote Progetto	459.98	459.64	459.58	459.51
Parziali		2.50	2.50	
Progressiva	-2.55	-2.50	0.00	2.50
Dislivelli	0.00	0.05	-0.41	-0.47
				-0.00

Sezione: 35
 Progressiva: 236.767
 Q. Progetto: 459.991

458.00

Quote Terreno	460.00	459.99	459.99	459.99
Quote Progetto	459.99	459.65	459.59	459.53
Parziali		2.50	2.50	
Progressiva	-2.56	-2.50	0.00	2.50
Dislivelli	-0.00	0.06	-0.40	-0.46
				-0.00

Sezione: 36
 Progressiva: 239.080
 Q. Progetto: 460.007

458.00

Quote Terreno	460.02	460.01	460.00	460.00
Quote Progetto	460.01	459.67	459.61	459.54
Parziali		2.50	2.50	
Progressiva	-2.56	-2.50	0.00	2.50
Dislivelli	-0.00	0.06	-0.40	-0.46
				-0.00

Sezione: 37
 Progressiva: 240.000
 Q. Progetto: 460.013

458.00

Quote Terreno	460.03	460.02	460.01	460.00
Quote Progetto	460.02	459.55	459.61	459.55
Parziali		2.50	2.50	
Progressiva	-2.57	-2.50	0.00	2.50
Dislivelli	0.00	-0.07	-0.40	-0.45
				-0.00

Sezione: 38
 Progressiva: 260.000
 Q. Progetto: 460.250

458.00

Quote Terreno	460.38	460.34		460.27	460.17
Quote Progetto		460.32	459.79	459.85	459.79
Parziali			2.50	2.50	
Progressiva		-2.64	-2.50	0.00	2.50
Dislivelli		0.00	-0.13	-0.42	-0.43
					0.00

Sezione: 39
 Progressiva: 280.000
 Q. Progetto: 460.541

459.00

Quote Terreno	460.72		460.57	460.54	460.50	460.42
Quote Progetto		460.65	460.08	460.14	460.08	
Parziali			2.50	2.50		
Progressiva		-2.67	-2.50	0.00	2.50	
Dislivelli		0.00	-0.16	-0.41	-0.40	

Sezione: 40
 Progressiva: 280.353
 Q. Progetto: 460.546

459.00

Quote Terreno	460.72		460.60	460.56	460.55	460.48	460.42
Quote Progetto		460.65	460.21	460.15	460.08		
Parziali			2.50	2.50			
Progressiva		-2.54	-2.50	0.00	2.50		
Dislivelli		-0.00	-0.04	-0.41	-0.40		

Sezione: 41
 Progressiva: 284.611
 Q. Progetto: 460.603

459.00

Quote Terreno	460.76		460.65	460.60		460.46
Quote Progetto		460.27		460.20		460.14
Parziali			2.50	2.50		
Progressiva		-2.52		0.00		2.50
Dislivelli		-0.00		-0.40		-0.38

Sezione: 42
 Progressiva: 288.870
 Q. Progetto: 460.638

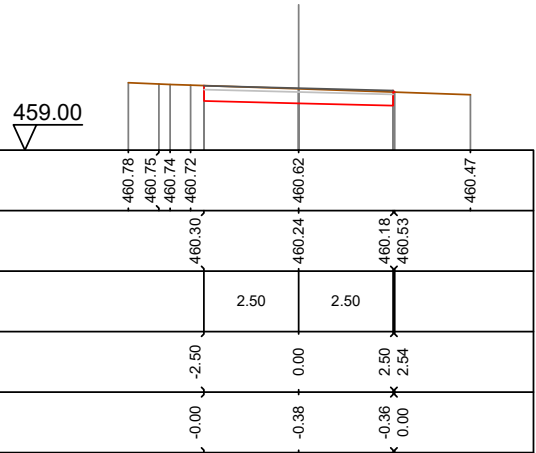

Sezione: 43
 Progressiva: 300.000
 Q. Progetto: 460.622

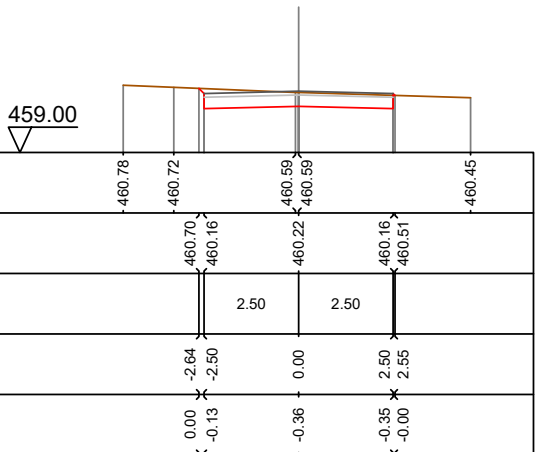

Sezione: 44
 Progressiva: 320.000
 Q. Progetto: 460.373

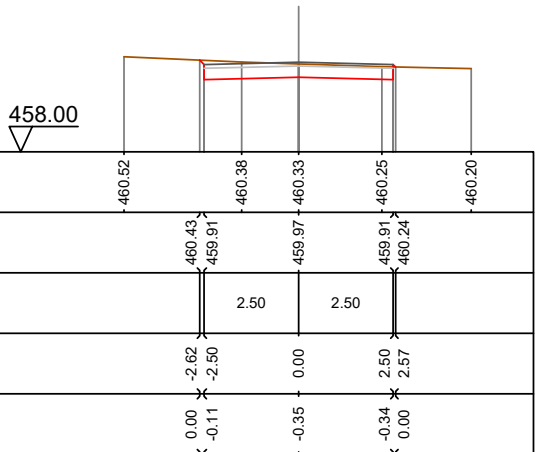

Sezione: 45
 Progressiva: 321.391
 Q. Progetto: 460.342

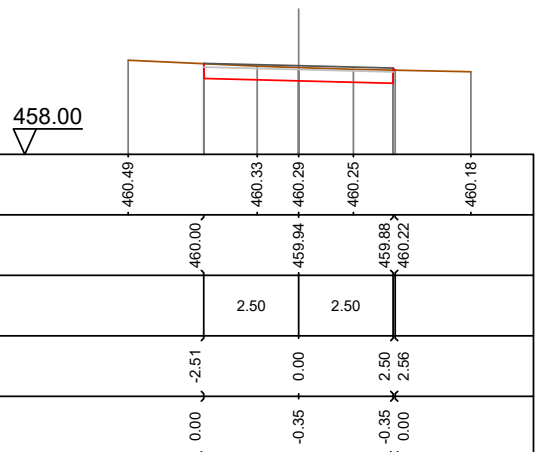

Sezione: 46
 Progressiva: 330.000
 Q. Progetto: 460.065

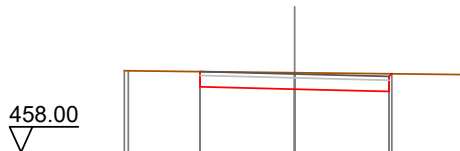

Quote Terreno	460.16	460.15		460.10	460.05
Quote Progetto		459.73		459.67	459.60 460.07
Parziali			2.50	2.50	
Progressiva		-2.50		0.00	2.50 2.57
Dislivelli		0.00		-0.44	-0.47 -0.00

Sezione: 47
 Progressiva: 331.571
 Q. Progetto: 459.999

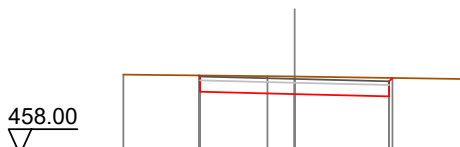

Quote Terreno	460.11		460.07	460.06	460.00
Quote Progetto		460.09 459.66		459.60	459.54 460.02
Parziali			2.50	2.50	
Progressiva		-2.53 -2.50		0.00	2.50 2.59
Dislivelli		-0.00 -0.03		-0.46	-0.49 0.00

Sezione: 48
 Progressiva: 340.000
 Q. Progetto: 459.558

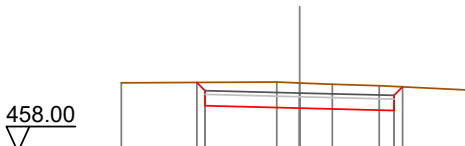

Quote Terreno	459.83		459.85	459.82	459.79	459.75	459.62
Quote Progetto		459.84 459.22		459.16		459.10 459.72	
Parziali			2.50	2.50			
Progressiva		-2.72 -2.50		0.00		2.50 2.73	
Dislivelli		0.00 -0.22		-0.67		-0.64 -0.00	

Sezione: 49
 Progressiva: 341.750
 Q. Progetto: 459.448

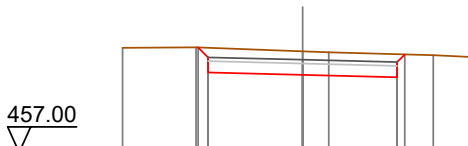

Quote Terreno	459.76	459.77	459.78	459.67	459.64	459.57	459.51
Quote Progetto		459.77 459.11		459.05		459.99 459.99	
Parziali			2.50	2.50			
Progressiva		-2.76 -2.50		0.00		2.50 2.70	
Dislivelli		-0.00 -0.25		-0.62		-0.61 0.00	

Sezione: 50
 Progressiva: 360.000
 Q. Progetto: 457.938

456.00

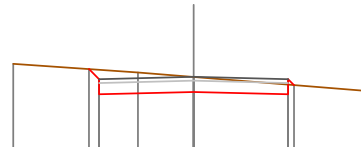

Quote Terreno	456.28	458.05	457.93	457.56
Quote Progetto	458.14 457.48	457.54	457.48 457.72	
Parziali	2.50	2.50		
Progressiva	-2.77 -2.50	0.00	2.50 2.66	
Dislivelli	0.00 -0.25	-0.40	-0.26 -0.00	

Sezione: 51
 Progressiva: 380.014
 Q. Progetto: 455.854

454.00

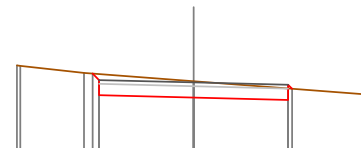

Quote Terreno	456.30 456.29	456.11	455.89	455.53
Quote Progetto	456.09 455.52	455.45	455.39 455.69	
Parziali	2.50	2.50		
Progressiva	-2.67 -2.50	0.00	2.50 2.60	
Dislivelli	0.00 -0.16	-0.43	-0.30 0.00	

Sezione: 52
 Progressiva: 381.766
 Q. Progetto: 455.690

454.00

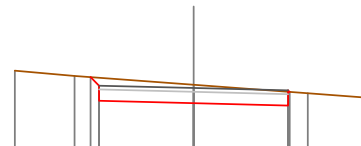

Quote Terreno	456.15	456.01	455.78	455.44
Quote Progetto	455.98 455.35	455.29	455.23 455.59	
Parziali	2.50	2.50		
Progressiva	-2.73 -2.50	0.00	2.50 2.54	
Dislivelli	0.00 -0.21	-0.49	-0.36 0.00	

Sezione: 53
 Progressiva: 383.518
 Q. Progetto: 455.532

454.00

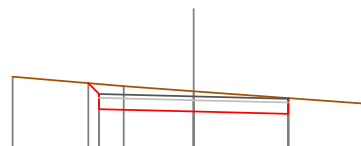

Quote Terreno	456.05	455.80	455.67	455.34
Quote Progetto	455.88 455.19	455.13	455.07	
Parziali	2.50	2.50		
Progressiva	-2.79 -2.50	0.00	2.50	
Dislivelli	0.00 -0.26	-0.54	-0.42	

Sezione: 54
 Progressiva: 400.000
 Q. Progetto: 454.199

452.00

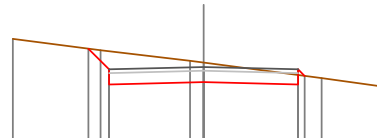

Quote Terreno	454.94	454.64	454.36	453.90	453.69
Quote Progetto		454.68 453.74	453.80 454.31	453.74 453.96	
Parziali		0.55	2.50	2.50	
Progressiva		-3.05 -2.50	0.00	2.50 2.67	
Dislivelli		0.00 -0.48	-0.52	-0.25 0.00	

Sezione: 55
 Progressiva: 410.457
 Q. Progetto: 453.485

451.00

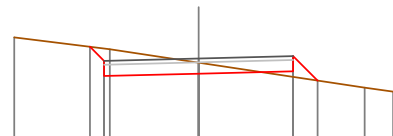

Quote Terreno	454.05	453.73	453.38	452.71	452.61
Quote Progetto		453.80 453.02	453.09 453.38	453.15 452.90	
Parziali		0.37	2.50	2.50	0.65
Progressiva		-2.87 -2.50	0.00	2.50 3.15	
Dislivelli		0.00 -0.33	-0.29	0.15 0.00	

Sezione: 56
 Progressiva: 414.198
 Q. Progetto: 453.284

451.00

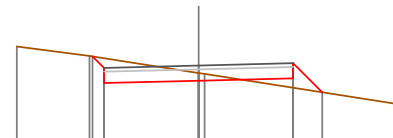

Quote Terreno	453.79	453.54	453.09	452.26	
Quote Progetto		453.53 452.82	452.88 453.06	452.95 452.58	
Parziali		0.31	2.50	2.50	0.77
Progressiva		-2.81 -2.50	0.00	2.50 3.27	
Dislivelli		0.00 -0.26	-0.20	0.25 0.00	

Sezione: 57
 Progressiva: 417.939
 Q. Progetto: 453.110

451.00

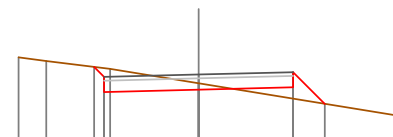

Quote Terreno	453.56	453.47	452.88	452.01	
Quote Progetto		453.31 452.65	452.71 452.88	452.77 452.33	
Parziali		0.26	2.50	2.50	0.84
Progressiva		-2.76 -2.50	0.00	2.50 3.34	
Dislivelli		0.00 -0.23	-0.17	0.30 0.00	

Sezione: 58
 Progressiva: 420.000
 Q. Progetto: 453.026

451.00

Quote Terreno	453.45		452.92 452.85		452.02
Quote Progetto		453.21 452.56		452.63 452.56	452.35
Parziali		2.50	2.50	0.62	
Progressiva		-2.74 -2.50	0.00	2.50 3.12	
Dislivelli		0.00 -0.21	-0.23	0.12 0.00	

Sezione: 59
 Progressiva: 440.000
 Q. Progetto: 452.642

451.00

Quote Terreno	453.21		452.90	452.80	452.53 452.51
Quote Progetto		453.09 452.18	452.24	452.18 452.70	
Parziali		0.51 2.50	2.50		
Progressiva		-3.01 -2.50	0.00	2.50 2.63	
Dislivelli		-0.00 -0.48	-0.66	-0.54 0.00	

Sezione: 60
 Progressiva: 450.332
 Q. Progetto: 452.446

450.00

Quote Terreno	452.66 452.96		452.42 452.41		451.99
Quote Progetto		452.50 451.96	452.05	452.11 452.18	
Parziali		2.50	2.50	0.33	
Progressiva		-2.62 -2.50	0.00	2.50 2.83	
Dislivelli		0.00 -0.11	-0.37	-0.10 -0.00	

Sezione: 61
 Progressiva: 453.852
 Q. Progetto: 452.330

450.00

Quote Terreno	452.18 452.18		452.00	451.95	451.94 451.85 451.77
Quote Progetto		452.11 451.87	451.93	451.99 451.92	
Parziali		2.50	2.50	0.47	
Progressiva		-2.66 -2.50	0.00	2.50 2.97	
Dislivelli		-0.00 0.17	-0.07	0.05 -0.00	

Sezione: 62
 Progressiva: 457.373
 Q. Progetto: 452.192

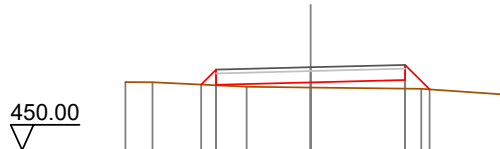

Quote Terreno	451.80	451.79	451.68	451.66	451.62	451.47
Quote Progetto		451.73	451.73	451.79	451.85	451.61
Parziali		0.40	2.50	2.50	0.65	
Progressiva		-2.90	-2.50	0.00	2.50	3.15
Dislivelli		-0.00	0.41	0.14	0.23	0.00

Sezione: 63
 Progressiva: 460.000
 Q. Progetto: 452.093



Quote Terreno	451.47	451.48	451.48	451.43	451.40	451.26
Quote Progetto		451.47	451.63	451.69	451.63	451.40
Parziali		0.56	2.50	2.50	0.63	
Progressiva		-3.06	-2.50	0.00	2.50	3.13
Dislivelli		0.00	0.57	0.26	0.23	-0.00

Sezione: 64
 Progressiva: 480.000
 Q. Progetto: 451.795

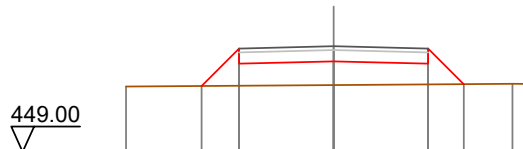

Quote Terreno	450.73	450.74	451.33	451.40	450.77	450.80	450.80
Quote Progetto		450.74	451.33	451.40	451.33	450.79	
Parziali		0.99	2.50	2.50	0.94		
Progressiva		-3.49	-2.50	0.00	2.50	3.44	
Dislivelli		0.00	0.98	0.63	0.55	0.00	

Sezione: 65
 Progressiva: 484.066
 Q. Progetto: 451.833

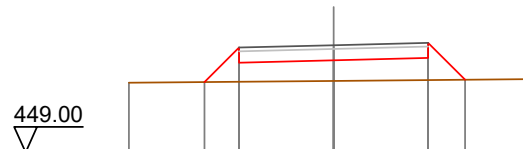

Quote Terreno	450.84	450.86	451.37	451.43	450.89	450.94
Quote Progetto		450.86	451.37	451.43	451.50	450.92
Parziali		0.91	2.50	2.50	0.98	
Progressiva		-3.41	-2.50	0.00	2.50	3.48
Dislivelli		-0.00	0.90	0.54	0.58	-0.00

Sezione: 66
 Progressiva: 488.592
 Q. Progetto: 451.913

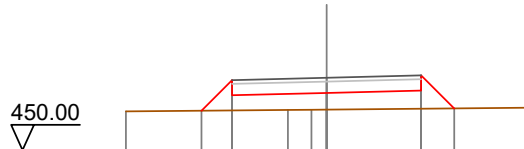

Quote Terreno	451.02		451.06	451.07	451.07	451.12
Quote Progetto		451.04	451.45	451.51	451.58	451.10
Parziali		0.81	2.50	2.50	0.87	
Progressiva		-3.31	-2.50	0.00	2.50	3.37
Dislivelli		-0.00	0.80	0.44	0.48	0.00

Sezione: 67
 Progressiva: 490.000
 Q. Progetto: 451.947

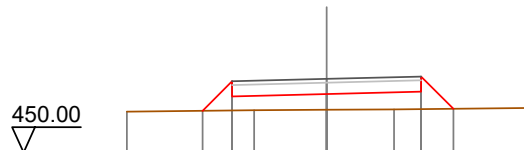

Quote Terreno	451.08		451.12	451.13	451.14	451.18
Quote Progetto		451.10	451.48	451.55	451.61	451.16
Parziali		0.78	2.50	2.50	0.85	
Progressiva		-3.28	-2.50	0.00	2.50	3.35
Dislivelli		0.00	0.77	0.42	0.46	0.00

Sezione: 68
 Progressiva: 493.119
 Q. Progetto: 452.035

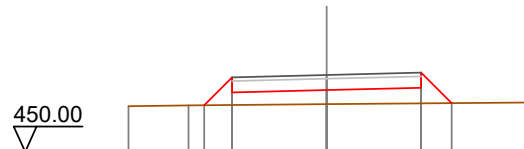

Quote Terreno	451.21	451.23		451.26		451.31
Quote Progetto		451.23	451.57	451.63	451.70	451.29
Parziali		0.74	2.50	2.50	0.81	
Progressiva		-3.24	-2.50	0.00	2.50	3.31
Dislivelli		0.00	0.73	0.37	0.41	-0.00

Sezione: 69
 Progressiva: 500.000
 Q. Progetto: 452.298

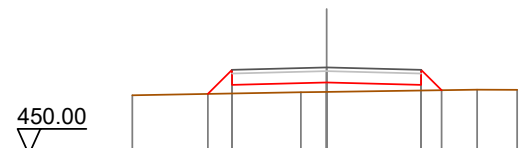

Quote Terreno	451.56		451.64	451.65		451.71
Quote Progetto		451.60	451.84	451.90	451.84	451.70
Parziali		0.64	2.50	2.50	0.54	
Progressiva		-3.14	-2.50	0.00	2.50	3.04
Dislivelli		0.00	0.63	0.25	0.15	0.00

Sezione: 70
 Progressiva: 520.000
 Q. Progetto: 453.604

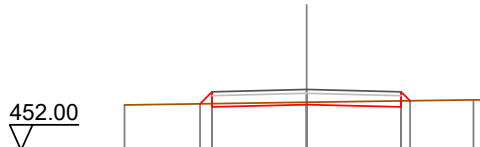

Quote Terreno	453.19		453.26		453.33	453.32
Quote Progetto		453.22 453.14	453.20		453.14 453.30	
Parziali		0.32 2.50	0.00		2.50	
Progressiva		-2.82 -2.50	0.00		2.50 2.74	
Dislivelli		0.00 0.31	-0.06		-0.16 0.00	

Sezione: 71
 Progressiva: 533.097
 Q. Progetto: 454.896

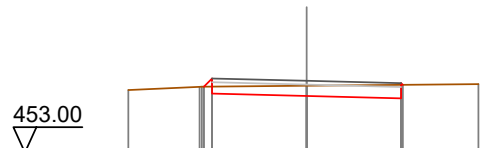

Quote Terreno	454.65	454.74 454.74	454.77		454.81	
Quote Progetto		454.74 454.66	454.50		454.43 454.79	
Parziali		2.50	0.00		2.50	
Progressiva		-2.72 -2.50	0.00		2.50 2.54	
Dislivelli		0.00 0.21	-0.27		-0.36 0.00	

Sezione: 72
 Progressiva: 535.742
 Q. Progetto: 455.200

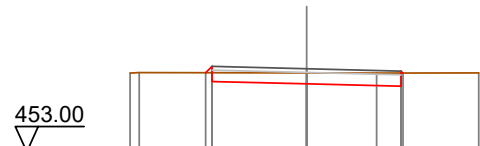

Quote Terreno	455.09 455.10		455.09		455.08	455.09
Quote Progetto		455.09 454.86	454.80		454.74 455.09	
Parziali		2.50	0.00		2.50	
Progressiva		-2.67 -2.50	0.00		2.50 2.55	
Dislivelli		-0.00 0.17	-0.29		-0.35 -0.00	

Sezione: 73
 Progressiva: 538.386
 Q. Progetto: 455.514

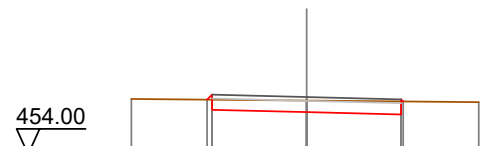

Quote Terreno	455.46		455.42		455.38	
Quote Progetto		455.44 455.18	455.11		455.05 455.40	
Parziali		2.50	0.00		2.50	
Progressiva		-2.63 -2.50	0.00		2.50 2.55	
Dislivelli		0.00 0.13	-0.31		-0.35 0.00	

Sezione: 74
 Progressiva: 540.000
 Q. Progetto: 455.707

454.00

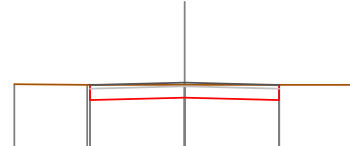

Quote Terreno	455.66	455.65	455.65	455.65
Quote Progetto		455.24	455.31	455.24
Parziali		2.50	2.50	
Progressiva		-2.50	0.00	2.50
Dislivelli		-0.00	-0.34	-0.40

Sezione: 75
 Progressiva: 560.000
 Q. Progetto: 457.907

456.00

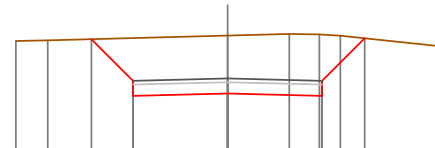

Quote Terreno	458.90	458.91	459.04	459.08	459.07	459.04	458.76
Quote Progetto		458.94	457.44	457.51	457.44	458.97	
Parziali		1.10	2.50	2.50	1.13		
Progressiva		-3.60	-2.50	0.00	2.50	3.63	
Dislivelli		0.00	-1.13	-1.53	-1.62	0.00	

Sezione: 76
 Progressiva: 580.190
 Q. Progetto: 459.347

457.00

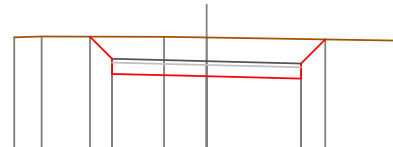

Quote Terreno	459.98	460.00	459.99	459.97	459.89	
Quote Progetto		460.00	459.01	458.95	458.88	459.92
Parziali		0.59	2.50	2.50	0.64	
Progressiva		-3.09	-2.50	0.00	2.50	3.14
Dislivelli		-0.00	-0.59	-1.03	-1.05	-0.00

Sezione: 77
 Progressiva: 584.286
 Q. Progetto: 459.540

458.00



Quote Terreno	459.89	460.00	460.00	460.00	459.94	
Quote Progetto		459.97	459.20	459.14	459.08	459.97
Parziali		0.36	2.50	2.50	0.50	
Progressiva		-2.86	-2.50	0.00	2.50	3.00
Dislivelli		0.00	-0.38	-0.86	-0.90	-0.00

Sezione: 78
 Progressiva: 588.381
 Q. Progetto: 459.698

458.00

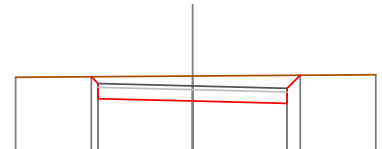

Quote Terreno	459.93		459.96	460.00
Quote Progetto	459.94 459.36		459.30	459.24 459.98
Parziali		2.50	2.50	0.34 0.34
Progressiva	-2.68 -2.50		0.00	2.50 2.84
Dislivelli	0.00 -0.18		-0.66	-0.74 -0.00

Sezione: 79
 Progressiva: 600.000
 Q. Progetto: 459.965

458.00

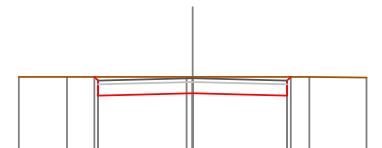

Quote Terreno	460.00	460.00	460.00	460.00	460.00	459.98
Quote Progetto	460.00	459.50	459.57	460.00	459.50	460.00
Parziali		2.50	2.50		2.50	
Progressiva	-2.60 -2.50		0.00	2.50	2.60	
Dislivelli	-0.00 -0.10		-0.43	-0.50	0.00	

Sezione: 80
 Progressiva: 620.000
 Q. Progetto: 460.017

458.00

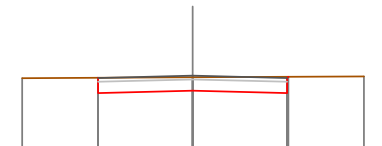

Quote Terreno	459.95		459.97	460.00
Quote Progetto	459.55		459.62	459.55 459.99
Parziali		2.50	2.50	0.34 0.34
Progressiva	-2.51 -2.50		0.00	2.50 2.53
Dislivelli	0.00 -0.10		-0.36	-0.43 0.00

Sezione: 81
 Progressiva: 630.775
 Q. Progetto: 460.033

458.00

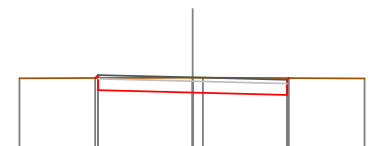

Quote Terreno	460.01		460.03	460.01
Quote Progetto	460.02	459.70	459.63	459.57
Parziali		2.50	2.50	0.34 0.34
Progressiva	-2.58 -2.50		0.00	2.50 2.55
Dislivelli	-0.00 0.08		-0.39	-0.45 -0.00

Sezione: 82
 Progressiva: 633.939
 Q. Progetto: 460.055

458.00

Quote Terreno	460.03	460.04	460.04	460.02
Quote Progetto	460.03	459.72	459.66	459.59
Parziali		2.50	2.50	
Progressiva	-2.58	-2.50	0.00	2.50
Dislivelli	-0.00	0.08	-0.39	-0.44

Sezione: 83
 Progressiva: 637.104
 Q. Progetto: 460.098

458.00

Quote Terreno	460.12	460.05	460.06	460.04	460.03
Quote Progetto	460.07	459.76	459.70	459.64	
Parziali		2.50	2.50		
Progressiva	-2.59	-2.50	0.00	2.50	
Dislivelli	0.00	0.09	-0.36	-0.41	

Sezione: 84
 Progressiva: 640.000
 Q. Progetto: 460.154

458.00

Quote Terreno	460.21	460.12	460.10	460.09	460.07	460.05
Quote Progetto	460.15	459.69	459.75	459.69	460.06	
Parziali		2.50	2.50			
Progressiva	-2.56	-2.50	0.00	2.50	2.53	
Dislivelli	-0.00	-0.06	-0.33	-0.37	-0.00	

Sezione: 85
 Progressiva: 660.000
 Q. Progetto: 460.986

459.00

Quote Terreno	461.32	460.95	460.67	460.60
Quote Progetto	461.16	460.52	460.52	460.74
Parziali		2.50	2.50	
Progressiva	-2.74	-2.50	0.00	2.50
Dislivelli	0.00	-0.22	-0.36	-0.23

Sezione: 86
 Progressiva: 674.024
 Q. Progetto: 461.750

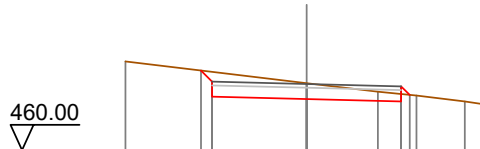

Quote Terreno	462.34			461.77		461.55		461.44		461.29		461.20
Quote Progetto		462.11		461.41		461.35		461.29		461.46		461.44
Parziali		0.28	2.50		2.50							
Progressiva		-2.79	-2.50		0.00			2.50		2.73		
Dislivelli		-0.00	-0.26		-0.42			-0.20		0.00		

Sezione: 87
 Progressiva: 678.623
 Q. Progetto: 461.954

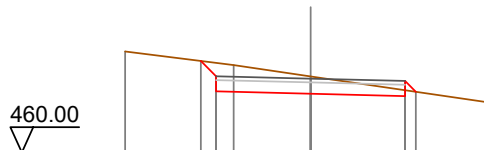

Quote Terreno	462.67			462.01						461.32
Quote Progetto		462.42		461.62		461.55		461.49		461.61
Parziali		0.40	2.50		2.50			0.28		
Progressiva		-2.90	-2.50		0.00			2.50		2.78
Dislivelli		0.00	-0.35		-0.46			-0.16		0.00

Sezione: 88
 Progressiva: 680.000
 Q. Progetto: 462.007

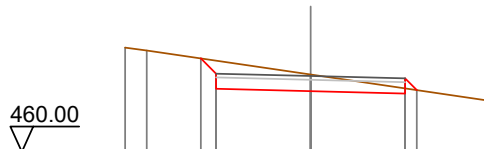

Quote Terreno	462.76	462.68				462.05				461.34
Quote Progetto			462.47		461.67		461.61		461.54	461.64
Parziali			0.40	2.50		2.50			0.31	
Progressiva			-2.90	-2.50		0.00			2.50	2.81
Dislivelli			0.00	-0.35		-0.44			-0.14	0.00

Sezione: 89
 Progressiva: 683.221
 Q. Progetto: 462.116

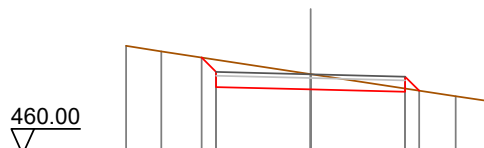

Quote Terreno	462.87	462.72		462.12				461.54		461.38
Quote Progetto			462.56		461.78		461.72		461.65	461.68
Parziali			0.38	2.50		2.50			0.37	
Progressiva			-2.88	-2.50		0.00			2.50	2.87
Dislivelli			-0.00	-0.32		-0.40			-0.09	-0.00

Sezione: 90
 Progressiva: 698.866
 Q. Progetto: 462.447

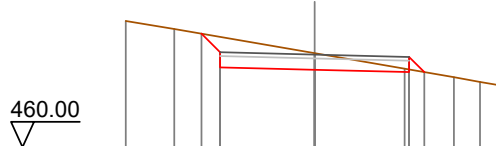

Quote Terreno	463.33	463.13		462.49	462.08	461.85	461.72	461.63
Quote Progetto			463.00	462.05	461.98	461.98		
Parziali			0.49	2.50	2.50	0.40		
Progressiva		-2.99	-2.50	0.00	2.50	2.90		
Dislivelli		0.00	-0.41	-0.44	-0.07	0.00		

Sezione: 91
 Progressiva: 700.000
 Q. Progetto: 462.458

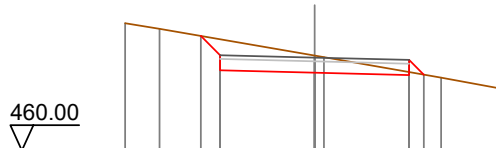

Quote Terreno	463.37	463.22		462.51	462.01	461.93	461.65
Quote Progetto			463.03	462.06	462.01		
Parziali			0.51	2.50	2.50	0.39	
Progressiva		-3.01	-2.50	0.00	2.50	2.89	
Dislivelli		0.00	-0.42	-0.45	-0.08	0.00	

Sezione: 92
 Progressiva: 703.807
 Q. Progetto: 462.478

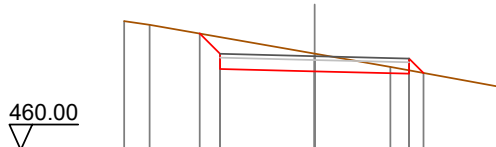

Quote Terreno	463.41	463.31		462.55	462.19		461.67
Quote Progetto			463.08	462.08	462.02	462.03	
Parziali			0.54	2.50	2.50	0.38	
Progressiva		-3.04	-2.50	0.00	2.50	2.88	
Dislivelli		0.00	-0.44	-0.47	-0.09	0.00	

Sezione: 93
 Progressiva: 708.748
 Q. Progetto: 462.462

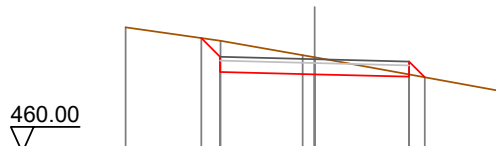

Quote Terreno	463.31	462.95		462.57	462.00		461.62
Quote Progetto			463.02	462.06	462.00	461.98	
Parziali			0.50	2.50	2.50	0.41	
Progressiva		-3.00	-2.50	0.00	2.50	2.91	
Dislivelli		0.00	-0.43	-0.45	-0.06	0.00	

Sezione: 94
 Progressiva: 720.000
 Q. Progetto: 462.438

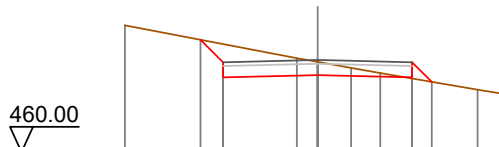

Quote Terreno		463.35			462.49	462.39	462.23	462.09		461.65	461.52
Quote Progetto			462.97	461.98	462.04			461.98	461.86		
Parziali			0.60	2.50		2.50		0.52			
Progressiva			-3.10	-2.50	0.00			2.50	3.02		
Dislivelli			-0.00	-0.48	-0.35			0.03	-0.00		

Sezione: 95
 Progressiva: 729.731
 Q. Progetto: 462.601

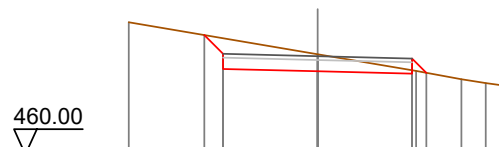

Quote Terreno		463.50			462.65			462.21	461.99	461.89	461.83
Quote Progetto			463.16	462.26	462.20			462.14	462.16		
Parziali			0.49	2.50		2.50		0.38			
Progressiva			-2.99	-2.50	0.00			2.50	2.88		
Dislivelli			-0.00	-0.41	-0.45			-0.09	0.00		

Sezione: 96
 Progressiva: 730.000
 Q. Progetto: 462.607

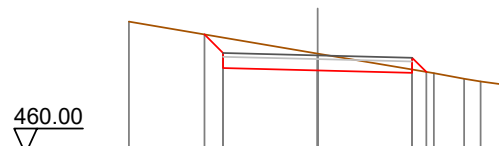

Quote Terreno		463.50			462.65			462.13	461.99	461.92	461.84
Quote Progetto			463.16	462.27	462.21			462.14	462.17		
Parziali			0.49	2.50		2.50		0.38			
Progressiva			-2.99	-2.50	0.00			2.50	2.88		
Dislivelli			0.00	-0.41	-0.45			-0.09	-0.00		

Sezione: 97
 Progressiva: 736.855
 Q. Progetto: 462.726

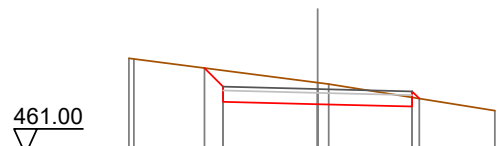

Quote Terreno		463.54	463.52		462.90	462.86				462.15
Quote Progetto				462.28	462.33			462.26	462.17	
Parziali				0.49	2.50		2.50			
Progressiva				-2.99	-2.50	0.00		2.50	2.69	
Dislivelli				-0.00	-0.43	-0.57		-0.24	0.00	

Sezione: 98
 Progressiva: 740.000
 Q. Progetto: 462.750

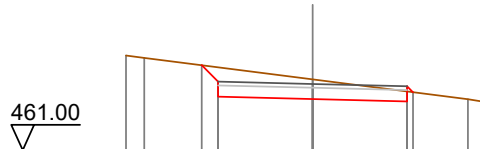

Quote Terreno	463.50	463.44		462.87		462.34	462.26
Quote Progetto			463.25	462.35	462.29	462.53	
Parziali			0.43	2.50	2.50		
Progressiva			-2.93	0.00	2.50	2.66	
Dislivelli			0.00	-0.38	-0.52	-0.26	0.00

Sezione: 98
 Progressiva: 740.000
 Q. Progetto: 462.750

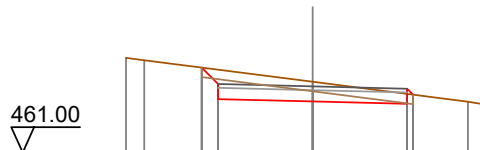

Quote Terreno	463.50	463.44		462.87		462.34	462.26
Quote Progetto			463.25	462.35	462.29	462.53	
Parziali			0.43	2.50	2.50		
Progressiva			-2.93	0.00	2.50	2.66	
Dislivelli			0.00	-0.38	-0.52	-0.26	0.00

Sezione: 99
 Progressiva: 743.979
 Q. Progetto: 462.752

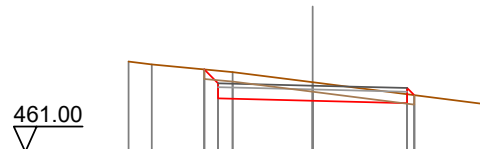

Quote Terreno	463.39	463.31		462.84		462.25	
Quote Progetto			463.18	462.35	462.29	462.50	
Parziali			0.37	2.50	2.50		
Progressiva			-2.87	0.00	2.50	2.69	
Dislivelli			0.00	-0.33	-0.49	-0.24	0.00

Sezione: 100
 Progressiva: 746.969
 Q. Progetto: 462.732

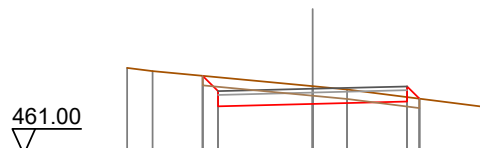

Quote Terreno	463.29	463.20		462.80	462.71	462.22	
Quote Progetto			463.08	462.33	462.39	462.47	
Parziali			0.41	2.50	2.50	0.32	
Progressiva			-2.91	0.00	2.50	2.82	
Dislivelli			0.00	-0.37	-0.47	-0.12	0.00

Sezione: 101
 Progressiva: 750.000
 Q. Progetto: 462.694

461.00

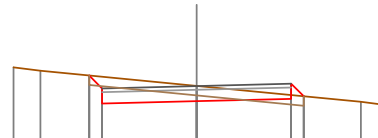

Quote Terreno	463.19	463.10		462.70		462.28	462.22
Quote Progetto			462.97	462.23		462.36	462.42
Parziali			0.34	2.50		2.50	0.33
Progressiva		-2.84	-2.50	0.00		2.50	2.83
Dislivelli		0.00	-0.31	-0.40		-0.10	-0.00

Sezione: 102
 Progressiva: 760.000
 Q. Progetto: 462.439

460.00

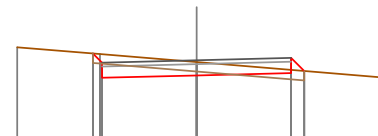

Quote Terreno	462.78		462.60		462.39		461.99
Quote Progetto		462.62	461.98		462.04		462.10
Parziali			2.50		2.50		0.35
Progressiva		-2.74	-2.50	0.00		2.50	2.85
Dislivelli		0.00	-0.22	-0.35		-0.08	-0.00

Sezione: 103
 Progressiva: 770.000
 Q. Progetto: 462.044

460.00

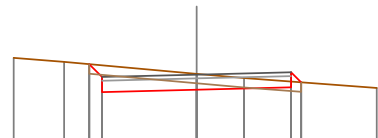

Quote Terreno	462.49	462.38		462.07		461.95	461.69
Quote Progetto		462.32	461.58		461.64	461.71	461.84
Parziali		0.34	2.50		2.50	0.27	
Progressiva		-2.84	-2.50	0.00		2.50	2.77
Dislivelli		0.00	-0.31	-0.42		-0.15	0.00

Sezione: 104
 Progressiva: 771.194
 Q. Progetto: 461.996

460.00

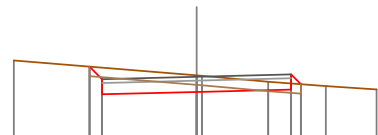

Quote Terreno	462.43		462.03		462.02		461.87
Quote Progetto		462.27	461.53		461.60		461.66
Parziali		0.33	2.50		2.50		0.16
Progressiva		-2.83	-2.50	0.00		2.50	2.76
Dislivelli		0.00	-0.31	-0.44		-0.16	0.00

Sezione: 105
 Progressiva: 780.000
 Q. Progetto: 461.612

460.00

Quote Terreno	462.07 462.05		461.66 461.61	461.35
Quote Progetto		461.91 461.15	461.21 461.21	461.27 461.48
Parziali		0.36 2.50	2.50	
Progressiva		-2.86 -2.50	0.00	2.50 2.70
Dislivelli		0.00 -0.33	-0.44	-0.21 0.00

Sezione: 106
 Progressiva: 790.000
 Q. Progetto: 461.000

459.00

Quote Terreno	461.65 461.56		461.24 461.21	460.99
Quote Progetto		461.50 460.54	460.60 460.60	460.66 461.10
Parziali		0.56 2.50	2.50	
Progressiva		-3.06 -2.50	0.00	2.50 2.53
Dislivelli		0.00 -0.51	-0.64	-0.44 -0.00

Sezione: 107
 Progressiva: 795.418
 Q. Progetto: 460.584

459.00

Quote Terreno	461.40 461.35		460.98 460.89	460.69 460.66
Quote Progetto		461.28 460.12	460.18 460.18	460.25 460.80
Parziali		0.75 2.50	2.50	
Progressiva		-3.25 -2.50	0.00	2.50 2.65
Dislivelli		0.00 -0.59	-0.80	-0.56 -0.00

Sezione: 108
 Progressiva: 797.656
 Q. Progetto: 460.395

458.00

Quote Terreno	461.15		460.96 460.89	460.76 460.55
Quote Progetto		461.07 459.93	460.00 460.00	460.06 460.88
Parziali		0.73 2.50	2.50	
Progressiva		-3.23 -2.50	0.00	2.50 2.72
Dislivelli		-0.00 -0.70	-0.90	-0.63 0.00

Sezione: 109
 Progressiva: 800.000
 Q. Progetto: 460.186

458.00

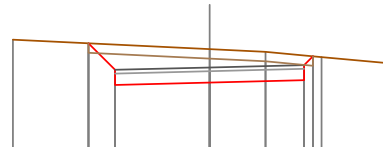

Quote Terreno		460.92		460.67	460.60	460.46	460.30
Quote Progetto			460.83	459.72	459.79	459.85	460.48
Parziali			0.70	2.50	2.50		
Progressiva			-3.20	-2.50	0.00	2.50	2.73
Dislivelli			0.00	-0.67	-0.88	-0.65	-0.00

Sezione: 110
 Progressiva: 810.000
 Q. Progetto: 459.170

457.00

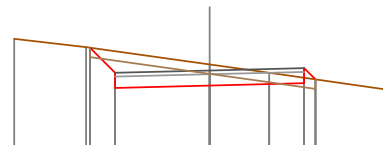

Quote Terreno		460.00	459.79	459.33	459.11	458.65
Quote Progetto			459.77	458.71	458.77	458.83
Parziali			0.67	2.50	2.50	0.30
Progressiva			-3.17	-2.50	0.00	2.50
Dislivelli			0.00	-0.57	-0.56	-0.14

Sezione: 111
 Progressiva: 816.874
 Q. Progetto: 458.354

456.00

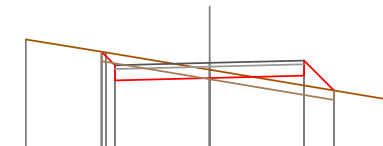

Quote Terreno		458.97	458.63	458.17		457.32	457.29
Quote Progetto			458.65	457.89	457.95	458.02	457.62
Parziali			0.36	2.50	2.50	0.79	
Progressiva			-2.86	-2.50	0.00	2.50	3.29
Dislivelli			0.00	-0.30	-0.22	0.26	0.00

Sezione: 112
 Progressiva: 820.000
 Q. Progetto: 457.965

455.00

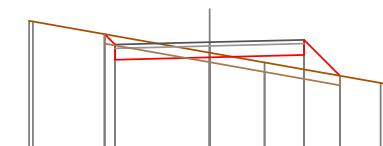

Quote Terreno		458.53	458.51	457.69	457.43	456.89	456.69
Quote Progetto			458.18	457.57	457.63	457.07	
Parziali			0.27	2.50	2.50	0.95	
Progressiva			-2.77	-2.50	0.00	2.50	3.45
Dislivelli			-0.00	-0.23	-0.12	0.38	-0.00

Sezione: 112
 Progressiva: 820.000
 Q. Progetto: 457.965

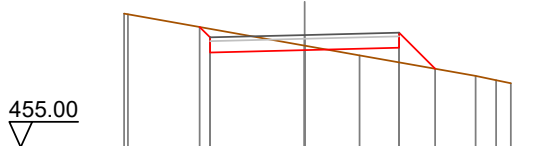

Quote Terreno	458.53	458.51			457.69	457.43		456.89	456.77	456.69
Quote Progetto			458.18	457.50	457.57		457.63	457.07		
Parziali			0.27	2.50		2.50	0.95			
Progressiva			-2.77	-2.50	0.00		2.50	3.45		
Dislivelli			0.00	-0.23	-0.12		0.38	0.00		

Sezione: 113
 Progressiva: 830.000
 Q. Progetto: 456.818

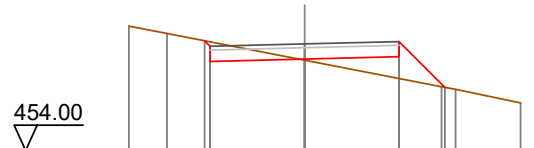

Quote Terreno	457.29	457.09			456.39			455.69	455.62	455.26
Quote Progetto			456.90	456.36	456.42		456.48	455.67		
Parziali				2.50		2.50	1.21			
Progressiva			-2.65	-2.50	0.00		2.50	3.71		
Dislivelli			-0.00	-0.12	0.03		0.58	0.00		

Sezione: 114
 Progressiva: 836.092
 Q. Progetto: 456.220

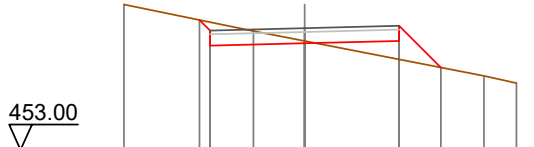

Quote Terreno	456.84				456.14			455.88	455.18	454.96	454.77
Quote Progetto			456.44	455.76	456.220		455.88	455.18			
Parziali			0.28	2.50		2.50	1.10				
Progressiva			-2.78	-2.50	0.00		2.50	3.60			
Dislivelli			0.00	-0.22	-0.06		0.49	0.00			

Sezione: 115
 Progressiva: 840.000
 Q. Progetto: 455.875

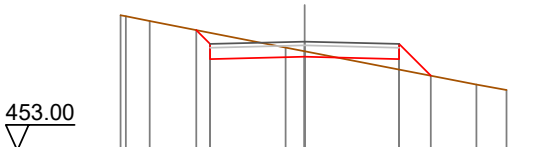

Quote Terreno	456.57	456.55	456.42		455.72	455.62		454.97	454.74	454.60
Quote Progetto			456.18	455.41	455.48		455.41	454.97		
Parziali			0.37	2.50		2.50	0.84			
Progressiva			-2.87	-2.50	0.00		2.50	3.34		
Dislivelli			0.00	-0.29	-0.15		0.28	0.00		

Sezione: 116
 Progressiva: 854.828
 Q. Progetto: 454.848

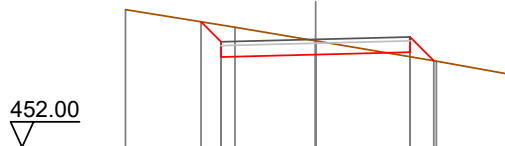

Quote Terreno		455.64		455.17		454.81		454.27		453.92
Quote Progetto			455.32	454.39		454.45		454.51		
Parziali			0.53	2.50		2.50		0.63		
Progressiva			-3.03	-2.50		0.00		2.50		3.13
Dislivelli			0.00	-0.44		-0.36		0.12		0.00

Sezione: 117
 Progressiva: 858.354
 Q. Progetto: 454.669

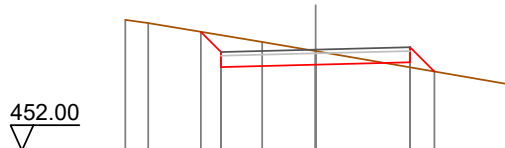

Quote Terreno		455.46		455.37		454.87		454.63		453.74
Quote Progetto			455.14	454.21		454.27		454.33		
Parziali			0.53	2.50		2.50		0.64		
Progressiva			-3.03	-2.50		0.00		2.50		3.14
Dislivelli			-0.00	-0.45		-0.36		0.13		0.00

Sezione: 118
 Progressiva: 860.000
 Q. Progetto: 454.594

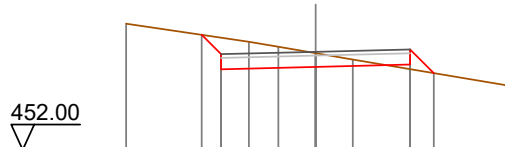

Quote Terreno		455.34		454.86		454.73		454.56		454.39		453.70
Quote Progetto			455.04	454.13		454.19		454.26		454.03		
Parziali			0.51	2.50		2.50		0.63				
Progressiva			-3.01	-2.50		0.00		2.50		3.13		
Dislivelli			0.00	-0.44		-0.37		0.12		-0.00		

Sezione: 119
 Progressiva: 861.879
 Q. Progetto: 454.515

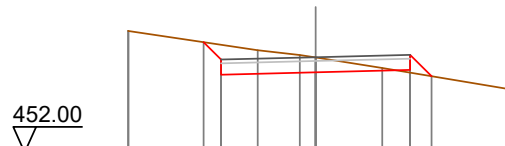

Quote Terreno		455.21		454.70		454.57		454.51		454.23		453.68
Quote Progetto			454.91	454.05		454.11		454.18		454.01		
Parziali			0.46	2.50		2.50		0.56				
Progressiva			-2.96	-2.50		0.00		2.50		3.06		
Dislivelli			0.00	-0.39		-0.39		0.07		-0.00		

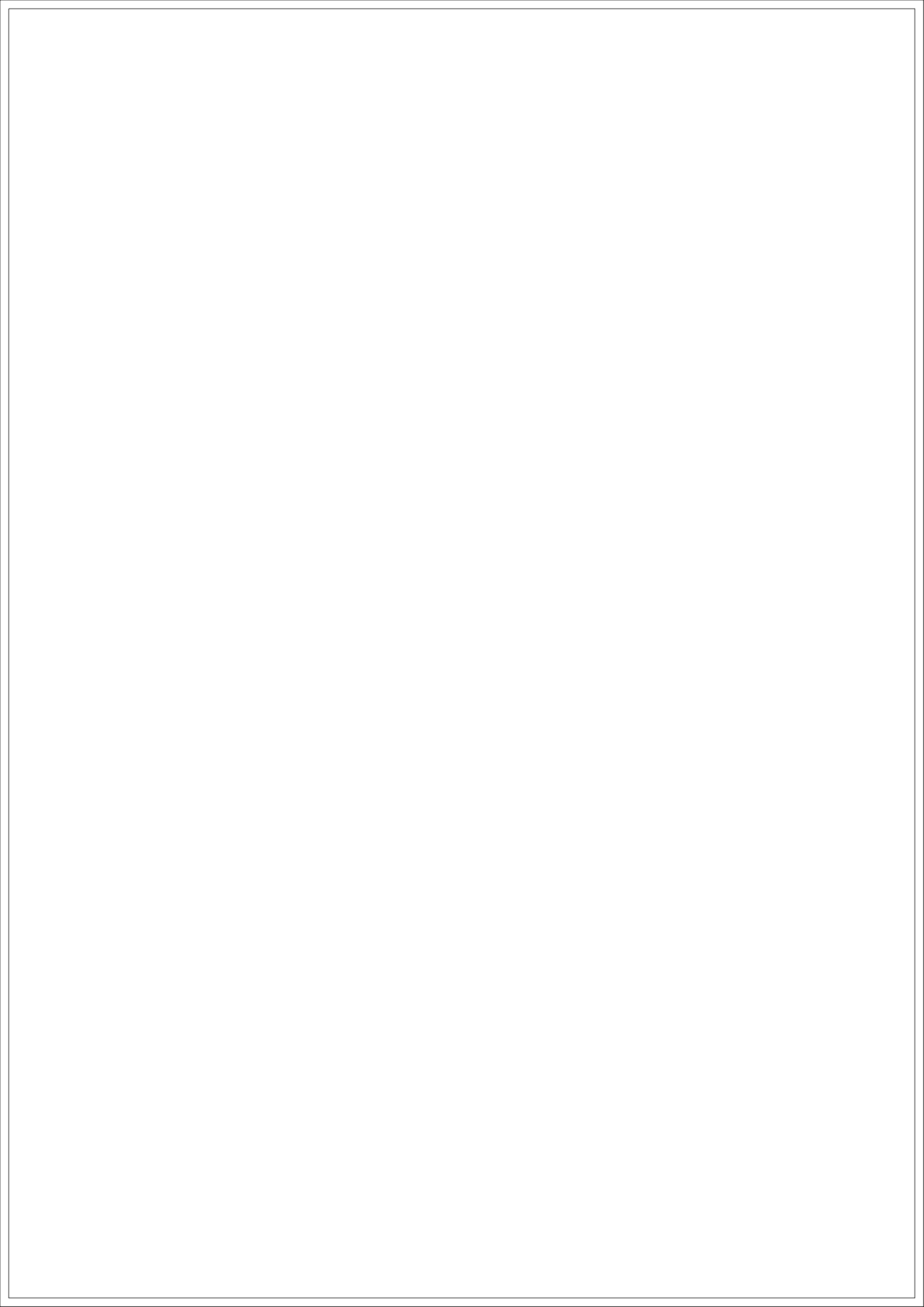

SEZIONI TRASVERSALI

Profilo longitudinale tratto 9-10

Viabilità di accesso impianto 6-7a

Nota: Le canalette di deflusso delle acque meteoriche, non indicate nel presente elaborato, sono rappresentate graficamente nelle sezioni stradali tipo dell'elaborato "SR-VI-TC12_Piazzole aerogeneratori e strade di servizio - Particolari costruttivi", individuate planimetricamente nell'elaborato "SR-VI-TC13_Opere di regimazione acque superficiali - Planimetria generale" e quantificate nell'elaborato "SR-VI-RC6_Computo Metrico Estimativo opere civili".

DISEGNI DI RIFERIMENTO

TAVOLA	DESCRIZIONE
SR-VI-TC8.1	Piazzole e viabilità - Planimetria di progetto - Fase di cantiere
SR-VI-TC10	Profili longitudinali viabilità di impianto
SR-VI-TC12	Piazzole aerogeneratori e strade di servizio - Particolari costruttivi
SR-VI-TC13	Opere di regimazione acque superficiali - Planimetria generale

Sezione: 1
 Progressiva: 0.000
 Q. Progetto: 380.076

378.00

Quote Terreno	380.07	380.06	380.08	380.09	380.11
Quote Progetto	380.06	379.61	379.68	379.61	380.09
Parziali		2.50	2.50		
Progressiva		-2.55	0.00	2.50	2.57
Dislivelli	0.00	-0.05	-0.40	-0.47	0.00

Sezione: 2
 Progressiva: 20.000
 Q. Progetto: 380.170

378.00

Quote Terreno	380.76	381.05	381.26	381.29	381.31	381.33	381.48	381.59
Quote Progetto	381.05	379.71	379.77	379.77	379.71	381.48		
Parziali		0.94	2.50	2.50	1.38			
Progressiva		-3.44	-2.50	0.00	2.50	3.88		
Dislivelli	0.00	-1.06	-1.54	-1.70	0.00			

Sezione: 3
 Progressiva: 31.174
 Q. Progetto: 380.517

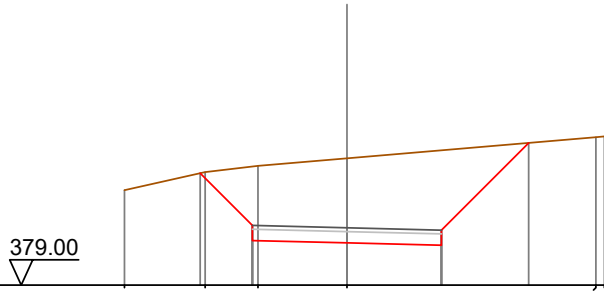

Quote Terreno	-381.51	-381.99	-382.16	-382.35	-382.91	-382.94
Quote Progetto		381.96	380.18	380.12	380.05	382.76
Parziali		1.38	2.50	2.50	2.31	
Progressiva		-3.88	-2.50	0.00	2.50	4.81
Dislivelli		-0.00	-1.56	-2.24	-2.51	-0.00

Sezione: 4
 Progressiva: 34.396
 Q. Progetto: 380.664

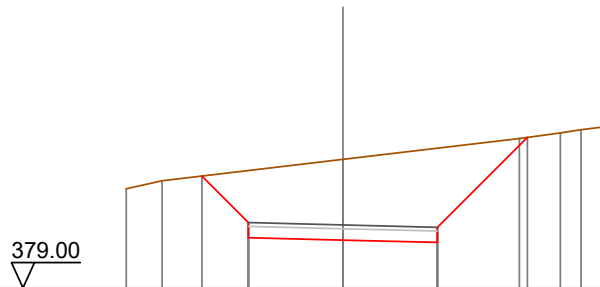

Quote Terreno	-381.62	-381.83	-382.40	-382.40	-382.95	-383.10	-383.18	-383.25
Quote Progetto		381.96	380.33	380.26	380.20	382.98		
Parziali		1.23	2.50	2.50	2.38			
Progressiva		-3.73	-2.50	0.00	2.50	4.88		
Dislivelli		0.00	-1.37	-2.13	-2.49	0.00		

Sezione: 5
 Progressiva: 37.618
 Q. Progetto: 380.831

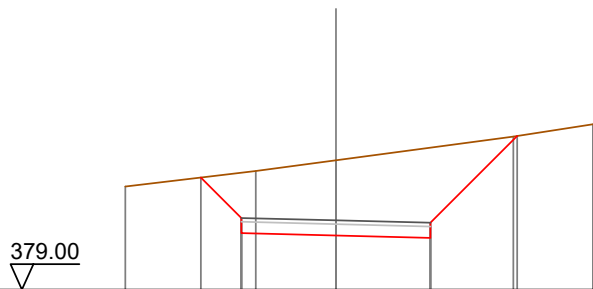

Quote Terreno	-381.73	-382.14	-382.42	-382.42	-383.05	-383.37
Quote Progetto		381.96	380.49	380.43	380.37	383.06
Parziali		1.07	2.50	2.50	2.29	
Progressiva		-3.57	-2.50	0.00	2.50	4.79
Dislivelli		0.00	-1.20	-1.99	-2.39	0.00

Sezione: 6
 Progressiva: 40.000
 Q. Progetto: 380.951

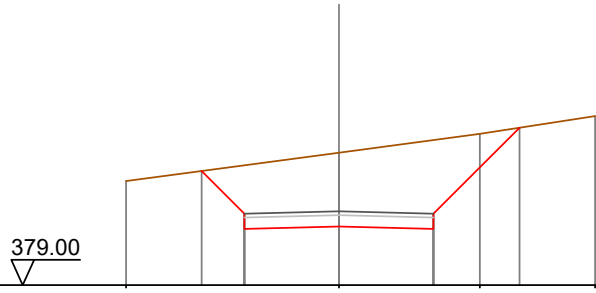

Quote Terreno		381.75		382.50		383.00		383.47
Quote Progetto			382.02	380.49	380.55	380.49	383.16	
Parziali			1.13	2.50	2.50	2.28		
Progressiva			-3.63	-2.50	0.00	2.50	4.78	
Dislivelli			0.00	-1.28	-1.95	-2.35	0.00	

Sezione: 7
 Progressiva: 50.865
 Q. Progetto: 381.357

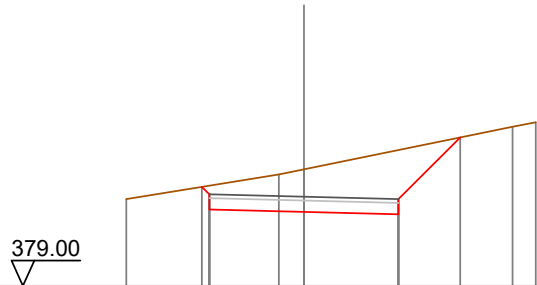

Quote Terreno		381.30		381.95		382.08		383.21	383.33
Quote Progetto			381.62	381.02	380.96	380.89	382.93		
Parziali				2.50	2.50	1.63			
Progressiva			-2.70	-2.50	0.00	2.50	4.13		
Dislivelli			0.00	-0.23	-1.12	-1.70	-0.00		

Sezione: 8
 Progressiva: 57.275
 Q. Progetto: 381.486

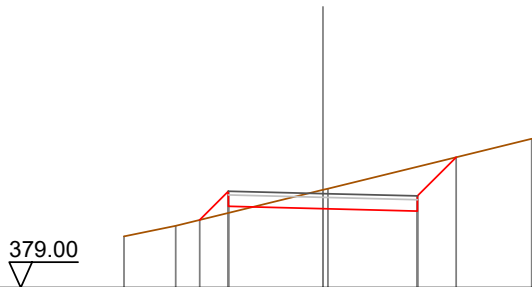

Quote Terreno		380.36		380.63		381.58		381.62		382.94	
Quote Progetto				380.79		381.15		381.09		381.02	382.45
Parziali				0.76		2.50		2.50		1.02	
Progressiva				-3.26		-2.50		0.00		2.50	3.52
Dislivelli				-0.00		0.57		-0.50		-1.17	-0.00

Sezione: 9
 Progressiva: 60.000
 Q. Progetto: 381.516

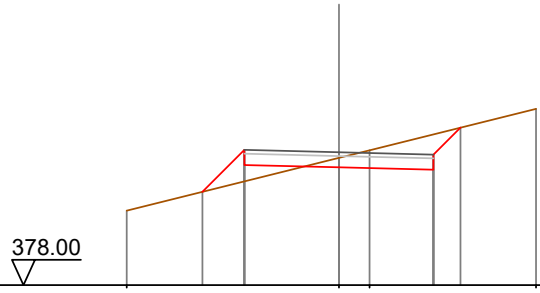

Quote Terreno		379.97			381.37	381.57		382.66
Quote Progetto			380.47	381.18	381.12		381.05	382.17
Parziali			1.11	2.50	2.50		0.71	
Progressiva			-3.61	-2.50	0.00		2.50	3.21
Dislivelli			-0.00	0.83	-0.25		-0.94	0.00

Sezione: 10
 Progressiva: 63.686
 Q. Progetto: 381.532

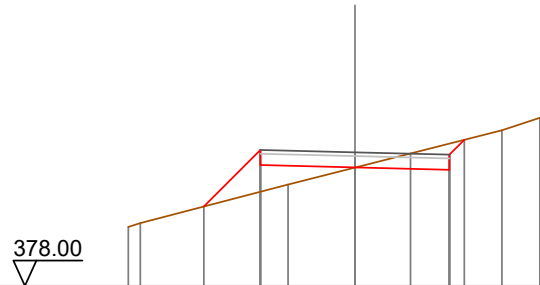

Quote Terreno		379.56	379.66		380.68	381.13	381.50		382.11	382.45
Quote Progetto				380.10	381.19	381.13		381.07	381.86	
Parziali				1.49	2.50	2.50		0.38		
Progressiva				-3.99	-2.50	0.00		2.50	2.89	
Dislivelli				0.00	1.10	0.00		-0.69	0.00	

Sezione: 11
 Progressiva: 78.261
 Q. Progetto: 381.397

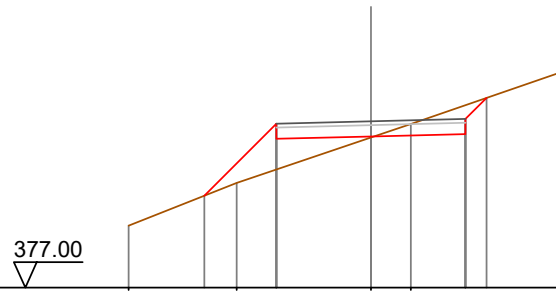

Quote Terreno		378.64		379.77		380.97	381.33		382.70
Quote Progetto			379.43	380.93	381.00		381.06	382.02	
Parziali			1.91	2.50	2.50		0.56		
Progressiva			-4.41	-2.50	0.00		2.50	3.06	
Dislivelli			-0.00	1.21	0.03		-0.77	0.00	

Sezione: 12
 Progressiva: 80.000
 Q. Progetto: 381.376

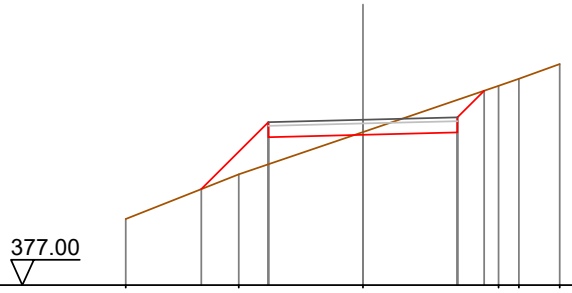

Quote Terreno	-378.75	-379.93	-380.91	-381.05	-382.27	-382.46	-382.85
Quote Progetto		-379.54	-380.91	-380.98	-381.04	-382.14	
Parziali		1.77	2.50	2.50	0.70		
Progressiva		-4.27	-2.50	0.00	2.50	3.20	
Dislivelli		-0.00	1.11	-0.08	-0.86	-0.00	

Sezione: 13
 Progressiva: 89.126
 Q. Progetto: 381.225

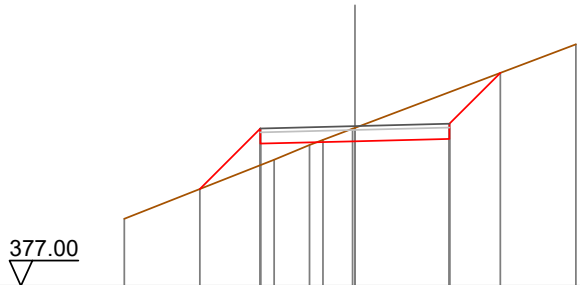

Quote Terreno	-378.77	-380.34	-380.73	-380.86	-381.16	-381.18	-383.39
Quote Progetto		-379.56	-380.76	-380.82	-380.89	-382.63	
Parziali		1.60	2.50	2.50	1.35		
Progressiva		-4.10	-2.50	0.00	2.50	3.85	
Dislivelli		-0.00	0.97	-0.36	-1.24	0.00	

Sezione: 14
 Progressiva: 90.000
 Q. Progetto: 381.202

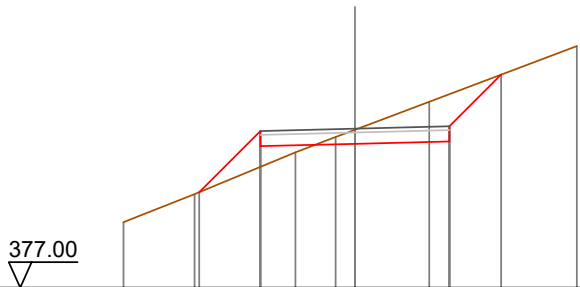

Quote Terreno	-378.73	-379.47	-380.57	-380.98	-381.17	-381.91	-383.39
Quote Progetto		-379.52	-380.74	-380.80	-380.86	-382.63	
Parziali		1.62	2.50	2.50	1.37		
Progressiva		-4.12	-2.50	0.00	2.50	3.87	
Dislivelli		-0.00	0.95	-0.37	-1.25	0.00	

Sezione: 15
 Progressiva: 99.991
 Q. Progetto: 380.836

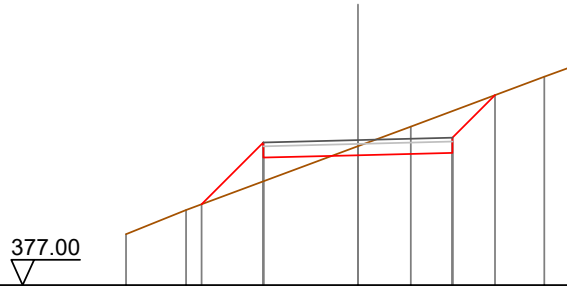

Quote Terreno	-378.35	-378.99	-380.37	-380.67	-381.19	-382.51	-382.77
Quote Progetto		379.14	380.37	380.44	380.50	382.03	
Parziali		1.63	2.50	2.50	1.13		
Progressiva		-4.13	-2.50	0.00	2.50	3.63	
Dislivelli		0.00	1.03	-0.24	-1.11	0.00	

Sezione: 16
 Progressiva: 120.000
 Q. Progetto: 379.619

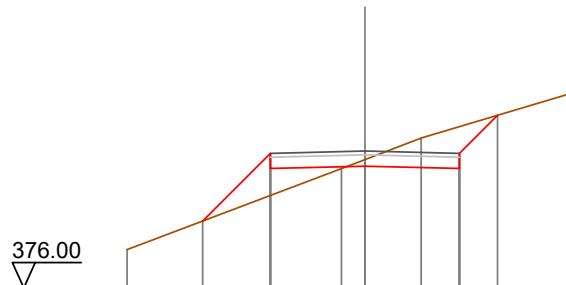

Quote Terreno	-377.01		-379.16	-379.39	-379.96	-381.16
Quote Progetto		377.77	379.16	379.22	379.16	380.56
Parziali		1.79	2.50	2.50	1.01	
Progressiva		-4.29	-2.50	0.00	2.50	3.51
Dislivelli		0.00	1.11	-0.17	-1.11	0.00

Sezione: 17
 Progressiva: 137.556
 Q. Progetto: 378.845

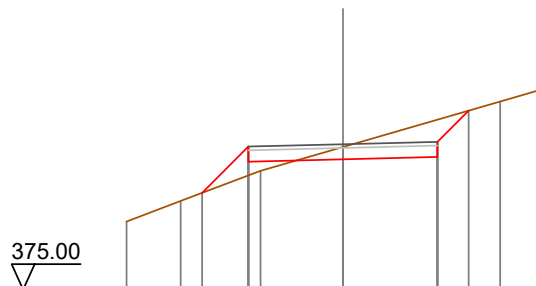

Quote Terreno	-376.80	-377.34	-378.14	-378.77	-379.97	-380.31
Quote Progetto		377.56	378.38	378.44	378.51	379.73
Parziali		1.22	2.50	2.50	0.82	
Progressiva		-3.72	-2.50	0.00	2.50	3.32
Dislivelli		0.00	0.76	-0.33	-0.99	0.00

Sezione: 18
 Progressiva: 140.000
 Q. Progetto: 378.768

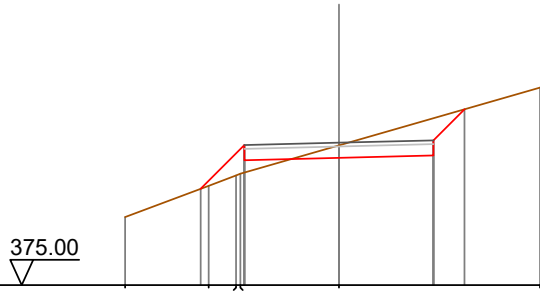

Quote Terreno		376.80	377.63	377.90	377.95	378.70	380.22
Quote Progetto			377.55	378.31		378.37	378.43
Parziali			1.16	2.50		2.50	0.82
Progressiva			-3.66	-2.50		0.00	2.50
Dislivelli			-0.00	0.73		-0.33	-0.98
							-0.00

Sezione: 19
 Progressiva: 142.871
 Q. Progetto: 378.677

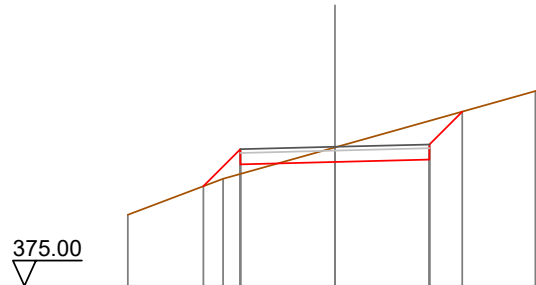

Quote Terreno		376.88	377.83		378.66	380.15	380.17
Quote Progetto			377.64	378.21	378.28	378.34	378.61
Parziali			0.98	2.50	2.50	0.87	
Progressiva			-3.48	-2.50	0.00	2.50	3.37
Dislivelli			-0.00	0.65		-1.02	0.00
							0.00

Sezione: 20
 Progressiva: 148.186
 Q. Progetto: 378.510

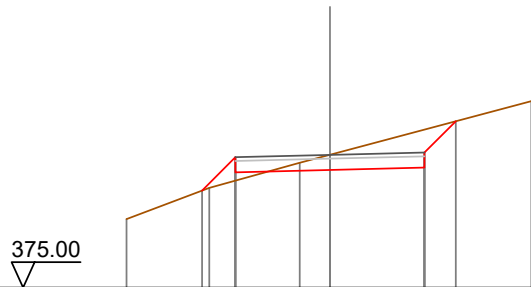

Quote Terreno		376.81	377.64	378.30	378.51	379.93
Quote Progetto			377.57	378.05	378.11	378.17
Parziali			0.88	2.50	2.50	0.83
Progressiva			-3.38	-2.50	0.00	2.50
Dislivelli			-0.00	0.62		-1.01
						0.00

Sezione: 21
 Progressiva: 160.000
 Q. Progetto: 378.277

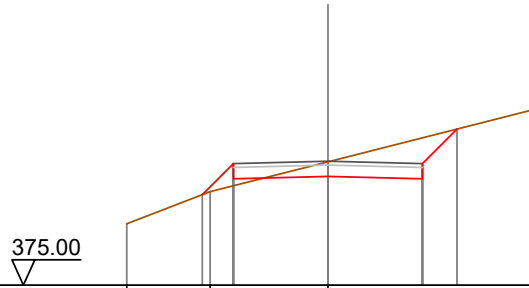

Quote Terreno	-376.62	-377.47	-378.26	-379.64
Quote Progetto		-377.39 -377.81	-377.88 -377.81	-379.13
Parziali		0.82	2.50	2.50
Progressiva		-3.32	-2.50	0.00
Dislivelli		0.00	0.58	-0.39

Sezione: 22
 Progressiva: 180.000
 Q. Progetto: 377.885

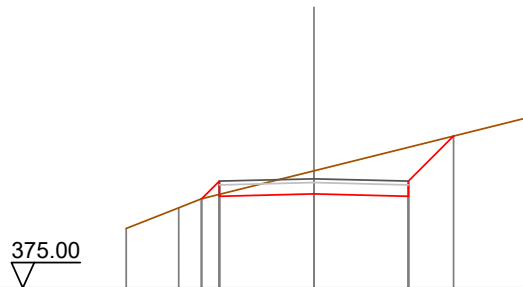

Quote Terreno	-376.57	-377.12 -377.35	-378.10	-379.52
Quote Progetto		-377.36 -377.42	-377.48 -377.42	-379.02
Parziali		0.47	2.50	2.50
Progressiva		-2.97	-2.50	0.00
Dislivelli		0.00	0.35	-0.61

Sezione: 23
 Progressiva: 195.237
 Q. Progetto: 377.056

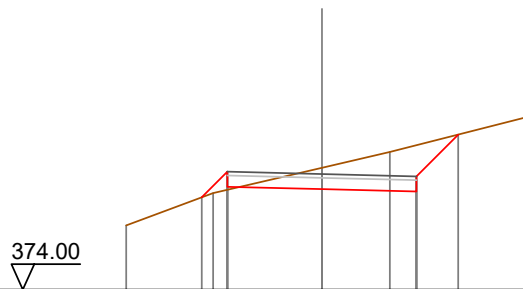

Quote Terreno	-375.70	-376.55 -376.55	-377.22	-377.64
Quote Progetto		-376.44 -376.72	-376.66 -377.22	-378.10
Parziali		0.68	2.50	2.50
Progressiva		-3.18	-2.50	0.00
Dislivelli		0.00	0.48	-0.56

Sezione: 24
 Progressiva: 196.490
 Q. Progetto: 376.967

374.00

Quote Terreno		375.57	376.44	377.12	377.81	378.48
Quote Progetto			376.32 376.63	376.57 377.12	376.50 377.81	377.96
Parziali			0.71	2.50	2.50	1.06
Progressiva			-3.21 -2.50	0.00	2.50	3.56
Dislivelli			0.00 0.50	-0.55	-1.20	0.00

SEZIONI TRASVERSALI

Profilo longitudinale tratto 10-11

Viabilità di accesso impianto 6-7b

Nota: Le canalette di deflusso delle acque meteoriche, non indicate nel presente elaborato, sono rappresentate graficamente nelle sezioni stradali tipo dell'elaborato "SR-VI-TC12_Piazzole aerogeneratori e strade di servizio - Particolari costruttivi", individuate planimetricamente nell'elaborato "SR-VI-TC13_Opere di regimazione acque superficiali - Planimetria generale" e quantificate nell'elaborato "SR-VI-RC6_Computo Metrico Estimativo opere civili".

DISEGNI DI RIFERIMENTO

TAVOLA	DESCRIZIONE
SR-VI-TC8.1	Piazzole e viabilità - Planimetria di progetto - Fase di cantiere
SR-VI-TC10	Profili longitudinali viabilità di impianto
SR-VI-TC12	Piazzole aerogeneratori e strade di servizio - Particolari costruttivi
SR-VI-TC13	Opere di regimazione acque superficiali - Planimetria generale

Sezione: 1
 Progressiva: 0.000
 Q. Progetto: 377.113

373.00

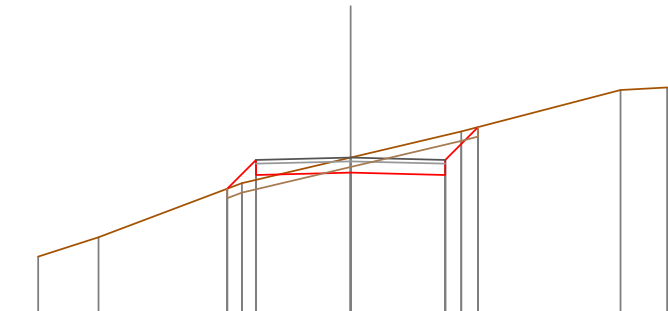
Quote Terreno	374.49	375.00	376.43	377.11	377.80	378.90	378.97
Quote Progetto			376.29	376.65	376.71	376.65	377.92
Parziali			0.76	2.50	2.50	0.87	
Progressiva			-3.26	-2.50	0.00	2.50	3.37
Dislivelli			0.00	0.53	-0.40	-1.05	0.00

Sezione: 2
 Progressiva: 16.474
 Q. Progetto: 376.203

372.00

Quote Terreno	373.45	374.88	375.29	375.52	376.80	376.96
Quote Progetto		374.77	375.87	375.80	375.74	376.04
Parziali		1.49	2.50	2.50		
Progressiva		-3.99	-2.50	0.00	2.50	2.60
Dislivelli		-0.00	1.20	0.28	-0.28	-0.00

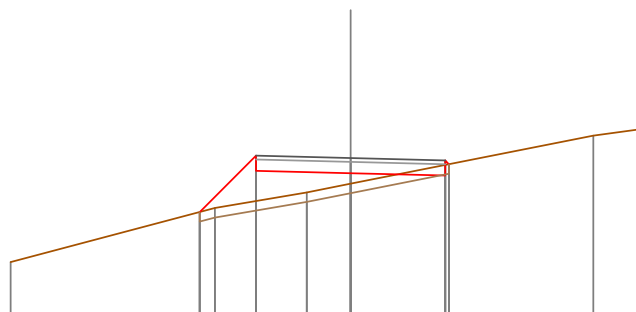
Sezione: 3
 Progressiva: 20.000
 Q. Progetto: 376.073

372.00

Quote Terreno	373.22	373.65	374.55	375.23	375.55	376.44	376.67
Quote Progetto			374.47	375.74	375.67	375.61	375.74
Parziali			1.66	2.50	2.50	0.27	
Progressiva			-4.16	-2.50	0.00	2.50	2.77
Dislivelli			0.00	1.34	0.44	-0.08	0.00

Sezione: 4
 Progressiva: 30.000
 Q. Progetto: 375.839

372.00

Quote Terreno	373.06	373.68	374.66	374.71	375.49	376.08	
Quote Progetto			373.98	375.50	375.44	375.38	375.27
Parziali			1.92	2.50	2.50	0.51	
Progressiva			-4.42	-2.50	0.00	2.50	3.01
Dislivelli			-0.00	1.61	0.73	0.20	0.00

Sezione: 5
 Progressiva: 37.456
 Q. Progetto: 375.795

372.00

Quote Terreno	373.16	373.82	374.60	374.82	375.47	375.85
Quote Progetto		373.85	375.46	375.40	375.33	375.09
Parziali		2.01	2.50	2.50	0.64	
Progressiva		-4.51	-2.50	0.00	2.50	3.14
Dislivelli		-0.00	1.67	0.79	0.34	0.00

Sezione: 6
 Progressiva: 40.000
 Q. Progetto: 375.798

372.00

Quote Terreno	373.19	373.96	374.60	375.82
Quote Progetto		373.87	375.46	375.07
Parziali		1.99	2.50	0.67
Progressiva		-4.49	-2.50	2.50
Dislivelli		0.00	1.68	0.36

Sezione: 7
 Progressiva: 50.000
 Q. Progetto: 375.807

372.00

Quote Terreno	373.36	373.39	373.60	374.63	375.25	375.41	375.79
Quote Progetto			374.04	375.47	375.41	375.34	375.07
Parziali			1.83	2.50	2.50	0.68	
Progressiva			-4.33	-2.50	0.00	2.50	3.18
Dislivelli			0.00	1.58	0.77	0.37	0.00

Sezione: 8
 Progressiva: 58.439
 Q. Progetto: 375.816

372.00

Quote Terreno	373.48	374.30	374.41	374.51	374.73	375.45	375.90
Quote Progetto		374.12	375.48	375.42	375.35	375.17	
Parziali		1.76	2.50	2.50	0.58		
Progressiva		-4.26	-2.50	0.00	2.50	3.08	
Dislivelli		0.00	1.52	0.69	0.26	-0.00	

Sezione: 9
 Progressiva: 59.315
 Q. Progetto: 375.817

372.00

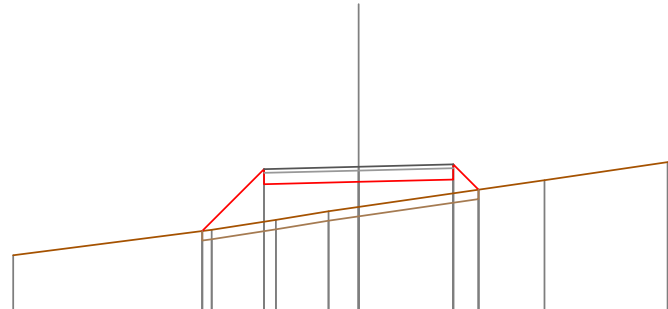
Quote Terreno	373.48	374.15	374.41	374.64	374.75	375.46	375.94
Quote Progetto		374.12	375.35	375.42	375.48	375.21	
Parziali		1.64	2.50	2.50	0.67		
Progressiva		-4.14	-2.50	0.00	2.50	3.17	
Dislivelli		0.00	1.39	0.66	0.37	0.00	

Sezione: 10
 Progressiva: 60.000
 Q. Progetto: 375.817

372.00

Quote Terreno	373.47	374.04	374.41	374.75	375.47	375.96
Quote Progetto		374.12	375.35	375.42	375.48	375.22
Parziali		1.64	2.50	2.50	0.66	
Progressiva		-4.14	-2.50	0.00	2.50	3.16
Dislivelli		0.00	1.38	0.67	0.36	0.00

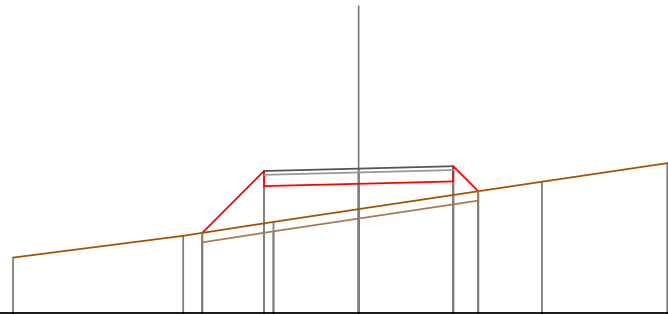
Sezione: 11
 Progressiva: 70.000
 Q. Progetto: 375.821

372.00

Quote Terreno	373.16	373.96	374.38	374.72	374.73	375.69	376.19
Quote Progetto		374.05	375.36	375.42	375.48	375.31	
Parziali		1.70	2.50	2.50	0.57		
Progressiva		-4.20	-2.50	0.00	2.50	3.07	
Dislivelli		0.00	1.44	0.70	0.28	0.00	

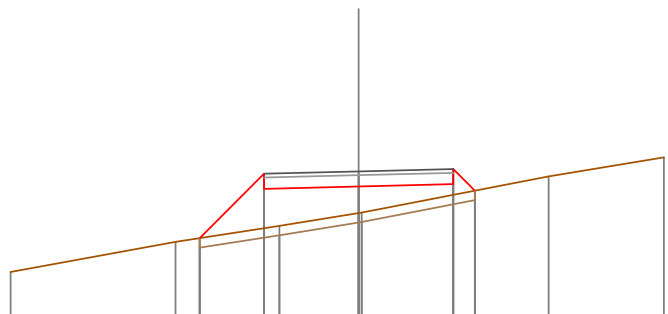
Sezione: 12
 Progressiva: 80.000
 Q. Progetto: 375.682

371.00

Quote Terreno	-372.45	-372.86	-373.10	-373.34	-373.99	-374.37	-375.58	-376.26
Quote Progetto				373.34	375.22	375.28	375.34	375.10
Parziali				2.28	2.50	2.50	0.65	
Progressiva			-4.78	-2.50	0.00	2.50	3.15	
Dislivelli			0.00	1.80	0.91	0.39	-0.00	

Sezione: 13
 Progressiva: 90.000
 Q. Progetto: 375.342

370.00

Quote Terreno	-371.65	-371.74	-373.27	-374.05	-374.31	-375.38	-376.27
Quote Progetto			372.88	374.88	374.94	375.00	374.88
Parziali			2.40	2.50	2.50	0.53	
Progressiva			-4.90	-2.50	0.00	2.50	3.03
Dislivelli			-0.00	1.80	0.89	0.29	-0.00

Sezione: 14
 Progressiva: 100.000
 Q. Progetto: 374.802

369.00

Quote Terreno	-370.93	-372.02	-372.89	-373.07	-374.15	-375.47
Quote Progetto		372.09	374.34	374.40	374.46	374.04
Parziali		2.65	2.50	2.50	0.83	
Progressiva		-5.15	-2.50	0.00	2.50	3.33
Dislivelli		0.00	2.18	1.34	0.67	0.00

Sezione: 15
 Progressiva: 105.997
 Q. Progetto: 374.382

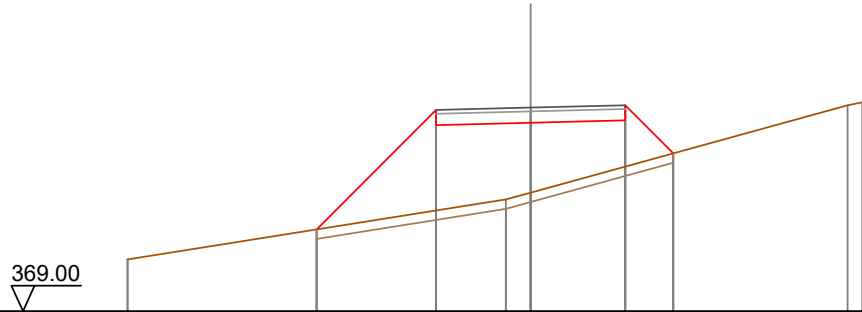

Quote Terreno		370.37				371.95	372.13			374.44	374.52
Quote Progetto			371.16		373.92		373.98		374.04		373.17
Parziali			3.16		2.50		2.50		1.27		
Progressiva			-5.66		-2.50		0.00		2.50		3.77
Dislivelli			0.00		2.66		1.85		1.22		-0.00

Sezione: 16
 Progressiva: 110.000
 Q. Progetto: 374.080

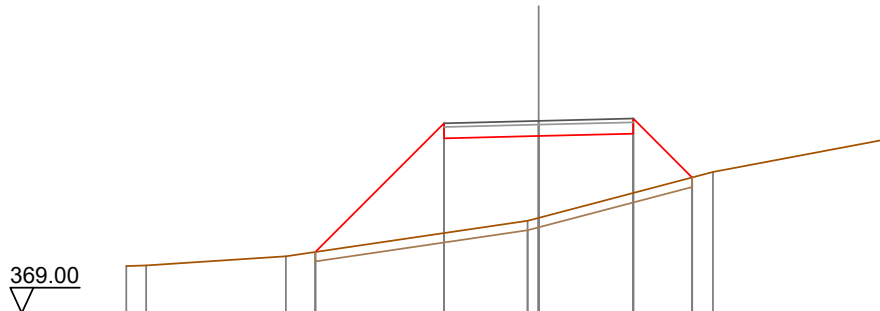

Quote Terreno		370.24	370.26		370.50			371.44	371.51		372.73	373.57
Quote Progetto					370.61		373.62		373.68		373.74	372.58
Parziali					3.41		2.50		2.50		1.56	
Progressiva					-5.91		-2.50		0.00		2.50	4.06
Dislivelli					0.00		2.90		2.17		1.57	-0.00

Sezione: 17
 Progressiva: 120.000
 Q. Progetto: 373.458

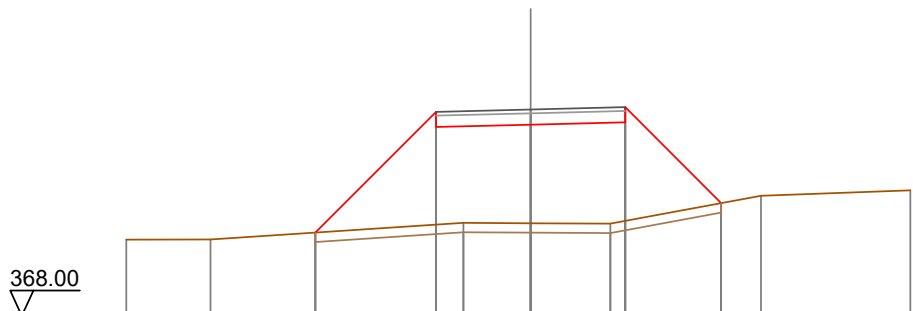

Quote Terreno		370.02	370.02			370.46	370.45		370.44		371.18	371.32
Quote Progetto					370.20		373.00		373.12		370.98	
Parziali					3.19		2.50		2.50		2.54	
Progressiva					-5.69		-2.50		0.00		2.50	5.04
Dislivelli					0.00		2.98		2.61		2.61	0.00

Sezione: 18
 Progressiva: 130.000
 Q. Progetto: 373.045

368.00

Quote Terreno	370.00	370.00	370.00	369.96	369.96			369.95	369.94
Quote Progetto		370.00	372.58	372.65	372.71	369.95			
Parziali			2.98	2.50	2.50	3.16			
Progressiva		-5.48	-2.50	0.00	2.50	5.66			
Dislivelli		0.00	3.01	2.68	2.75	-0.00			

Sezione: 19
 Progressiva: 140.000
 Q. Progetto: 372.852

368.00

Quote Terreno	370.00		369.98	369.94	369.88		369.76	369.55
Quote Progetto		369.98	372.39	372.45	372.51	369.81		
Parziali			2.81	2.50	2.50	3.10		
Progressiva		-5.31	-2.50	0.00	2.50	5.60		
Dislivelli		0.00	2.81	2.52	2.63	-0.00		

Sezione: 20
 Progressiva: 150.000
 Q. Progetto: 372.860

368.00

Quote Terreno	370.00	370.00	370.04	369.96	369.94	369.90		369.44
Quote Progetto			370.02	372.40	372.46	372.52	369.72	
Parziali			2.78	2.50	2.50	3.21		
Progressiva			-5.28	-2.50	0.00	2.50	5.71	
Dislivelli			0.00	2.81	2.52	2.63	0.00	

Sezione: 21
 Progressiva: 152.680
 Q. Progetto: 372.896

368.00

Quote Terreno	370.01	370.05		370.01	370.00	369.92	369.57
Quote Progetto		370.05	372.43	372.50	372.56	369.80	
Parziali			2.78	2.50	2.50	3.16	
Progressiva		-5.28	-2.50	0.00	2.50	5.66	
Dislivelli		0.00	2.80	2.48	2.62	-0.00	

Sezione: 22
 Progressiva: 153.089
 Q. Progetto: 372.902

368.00

Quote Terreno	370.01	370.06		369.98	370.02	369.91	369.59
Quote Progetto		370.05	372.44	372.50	372.56	369.82	
Parziali			2.79	2.50	2.50	3.15	
Progressiva		-5.29	-2.50	0.00	2.50	5.65	
Dislivelli		0.00	2.83	2.52	2.80	0.00	

Sezione: 23
 Progressiva: 160.000
 Q. Progetto: 373.067

368.00

Quote Terreno	370.21	370.10	370.11	370.25	370.37	370.19	370.31
Quote Progetto		370.12		372.67	372.73	370.28	
Parziali			2.89	2.50	2.50	2.85	
Progressiva		-5.39	-2.50	0.00	2.50	5.35	
Dislivelli		0.00	2.84	2.42	2.39	0.00	

Sezione: 24
 Progressiva: 168.876
 Q. Progetto: 373.419

369.00

Quote Terreno	370.89	370.96	371.02	371.22	371.41	371.65	
Quote Progetto			371.00	372.96	373.02	373.08	371.44
Parziali			2.36	2.50	2.50	2.04	
Progressiva			-4.86	-2.50	0.00	2.50	4.54
Dislivelli			-0.00	2.27	1.80	1.73	0.00

Sezione: 25
 Progressiva: 170.000
 Q. Progetto: 373.475

369.00

Quote Terreno	371.00	371.07	371.10	371.41	371.60	371.82	371.91
Quote Progetto			371.14	373.01	373.07	373.14	371.65
Parziali			2.27	2.50	2.50	1.89	
Progressiva			-4.77	-2.50	0.00	2.50	4.39
Dislivelli			-0.00	2.14	1.66	1.59	-0.00

Sezione: 26
 Progressiva: 180.000
 Q. Progetto: 374.083

371.00

Quote Terreno	372.54	372.56	372.78	373.28	373.44	374.13	
Quote Progetto			372.97	373.62	373.68	373.75	373.58
Parziali			1.06	2.50	2.50	0.57	
Progressiva			-3.56	-2.50	0.00	2.50	3.07
Dislivelli			0.00	0.96	0.40	0.23	-0.00

Sezione: 27
 Progressiva: 184.663
 Q. Progetto: 374.436

372.00

Quote Terreno	373.27		374.11	374.12	374.27	374.49	374.96
Quote Progetto		373.80	374.04		374.10	374.35	
Parziali		0.58	2.50		2.50		
Progressiva		-3.08	0.00		2.50	2.64	
Dislivelli		-0.00	-0.08		-0.24	0.00	

Sezione: 28
 Progressiva: 200.000
 Q. Progetto: 375.906

374.00

Quote Terreno	375.79	375.80	376.19	376.22	376.42	376.69	376.92
Quote Progetto			375.51		375.44	376.48	
Parziali			2.50		2.50	0.64	
Progressiva			0.00		2.50	3.14	
Dislivelli			-0.71		-0.97	-0.00	

Sezione: 29
 Progressiva: 220.000
 Q. Progetto: 377.627

376.00

Quote Terreno	378.42	378.46	378.51	378.52	378.60	378.76
Quote Progetto			377.23		377.16	378.60
Parziali			2.50		2.50	1.04
Progressiva			0.00		2.50	3.54
Dislivelli			-1.29		-1.41	0.00

Sezione: 30
 Progressiva: 224.105
 Q. Progetto: 377.882

376.00

Quote Terreno	378.93	378.92	378.91			378.96	378.97	378.97	379.13
Quote Progetto				378.93	377.54	377.48	377.42	378.97	
Parziali				0.99	2.50	2.50	1.16		
Progressiva				-3.49	-2.50	0.00	2.50	3.66	
Dislivelli				0.00	-1.00	-1.48	-1.55	0.00	

Sezione: 31
 Progressiva: 230.000
 Q. Progetto: 378.188

376.00

Quote Terreno	379.54	379.50	379.49			379.45	379.41	379.49	379.49
Quote Progetto			379.49	377.85	377.79	377.73	379.42		
Parziali			1.24	2.50	2.50	1.29			
Progressiva			-3.74	-2.50	0.00	2.50	3.79		
Dislivelli			0.00	-1.22	-1.66	-1.70	0.00		

Sezione: 32
 Progressiva: 231.472
 Q. Progetto: 378.254

376.00

Quote Terreno	379.69	379.64	379.64			379.57	379.52	379.56	379.57
Quote Progetto				379.61	377.92	377.85	377.79	379.53	
Parziali				1.30	2.50	2.50	1.34		
Progressiva				-3.80	-2.50	0.00	2.50	3.84	
Dislivelli				-0.00	-1.28	-1.71	-1.74	0.00	

Sezione: 33
 Progressiva: 238.839
 Q. Progetto: 378.517

377.00

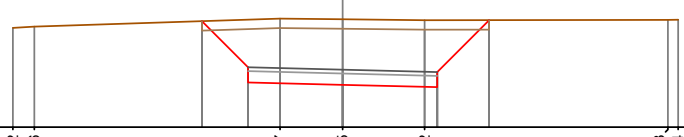

Quote Terreno	379.62	379.66		379.87	379.85	379.82		379.83	379.84
Quote Progetto			379.80	378.18	378.12	378.05	379.83		
Parziali			1.22	2.50	2.50	1.37			
Progressiva			-3.72	-2.50	0.00	2.50	3.87		
Dislivelli			-0.00	-1.26	-1.73	-1.77	0.00		

Sezione: 34
 Progressiva: 240.000
 Q. Progetto: 378.549

377.00

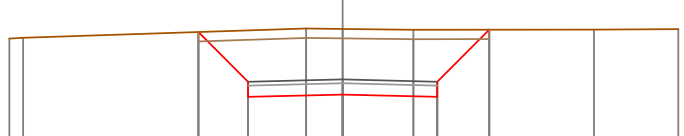

Quote Terreno	379.63	379.65		379.89	379.88	379.86		379.87	379.88
Quote Progetto			379.80	378.09	378.15	378.09	379.86		
Parziali			1.31	2.50	2.50	1.38			
Progressiva			-3.81	-2.50	0.00	2.50	3.88		
Dislivelli			-0.00	-1.36	-1.73	-1.78	0.00		

Sezione: 35
 Progressiva: 260.000
 Q. Progetto: 378.669

376.00



Quote Terreno	377.06	378.37	379.16	379.81	380.24	380.41
Quote Progetto		378.21	378.27	378.21	379.92	
Parziali		2.50	2.50	1.31		
Progressiva		-2.58	0.00	2.50	3.81	
Dislivelli		0.00	-0.89	-1.56	0.00	

Sezione: 36
 Progressiva: 269.242
 Q. Progetto: 378.455

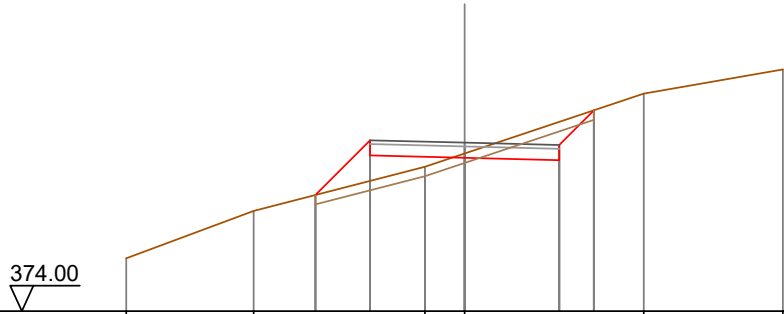

Quote Terreno	375.40	376.65			377.82	378.17		379.75	380.39
Quote Progetto			377.07	378.12	378.05	377.99	379.31		
Parziali				1.45	2.50	2.50	0.91		
Progressiva			-3.95	-2.50	0.00	2.50	3.41		
Dislivelli			-0.00	1.07	-0.11	-1.01	0.00		

Sezione: 37
 Progressiva: 270.000
 Q. Progetto: 378.430

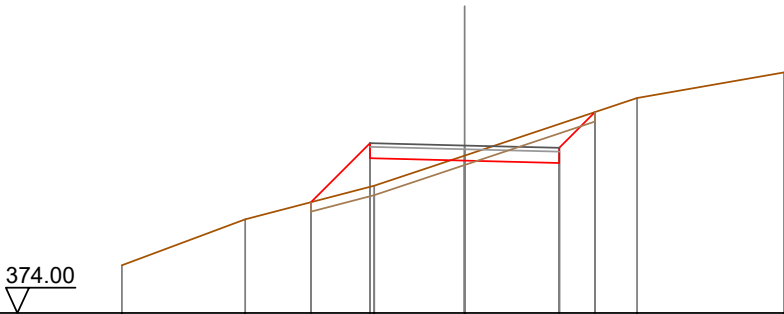

Quote Terreno	375.26	376.48			377.36	378.16		379.68	380.36
Quote Progetto			376.93	378.09	378.03	377.97	379.31		
Parziali				1.56	2.50	2.50	0.95		
Progressiva			-4.06	-2.50	0.00	2.50	3.45		
Dislivelli			0.00	1.16	-0.13	-1.03	-0.00		

Sezione: 38
 Progressiva: 275.811
 Q. Progetto: 378.239

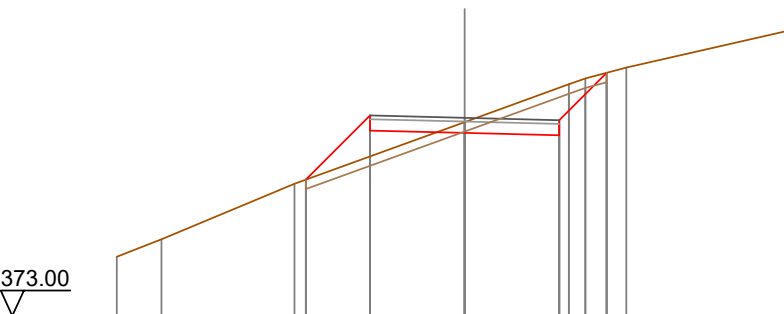

Quote Terreno	374.56	375.02			376.49	378.13		379.13	379.28	379.57	380.59
Quote Progetto			376.60	377.90	377.84	377.78	379.43				
Parziali				1.70	2.50	2.50	1.25				
Progressiva			-4.20	-2.50	0.00	2.50	3.75				
Dislivelli			0.00	1.08	-0.29	-1.26	-0.00				

Sezione: 39
 Progressiva: 280.000
 Q. Progetto: 378.110

373.00

Quote Terreno	374.25		377.00	378.02	378.36		379.70	380.81
Quote Progetto		376.36	377.77	377.71		377.65	379.41	
Parziali			1.82	2.50	2.50		1.36	
Progressiva		-4.32	-2.50	0.00		2.50	3.86	
Dislivelli		0.00	1.07	-0.31		-1.27	0.00	

Sezione: 40
 Progressiva: 282.380
 Q. Progetto: 378.052

373.00

Quote Terreno	374.20		375.98	377.27	377.90	378.01		379.92	380.88
Quote Progetto			376.31	377.71	377.65	378.01		379.43	
Parziali			1.80	2.50	2.50		1.44		
Progressiva		-4.30	-2.50	0.00		2.50	3.94		
Dislivelli		0.00	1.04	-0.36		-1.32	0.00		

Sezione: 41
 Progressiva: 295.773
 Q. Progetto: 377.913

373.00

Quote Terreno	374.28	374.78			377.26	377.91		379.33	381.12
Quote Progetto			376.31	377.45	377.51	377.91		379.50	
Parziali			1.54	2.50	2.50		1.65		
Progressiva			-4.04	-2.50	0.00		2.50	4.15	
Dislivelli			0.00	0.92	-0.40		-1.44	-0.00	

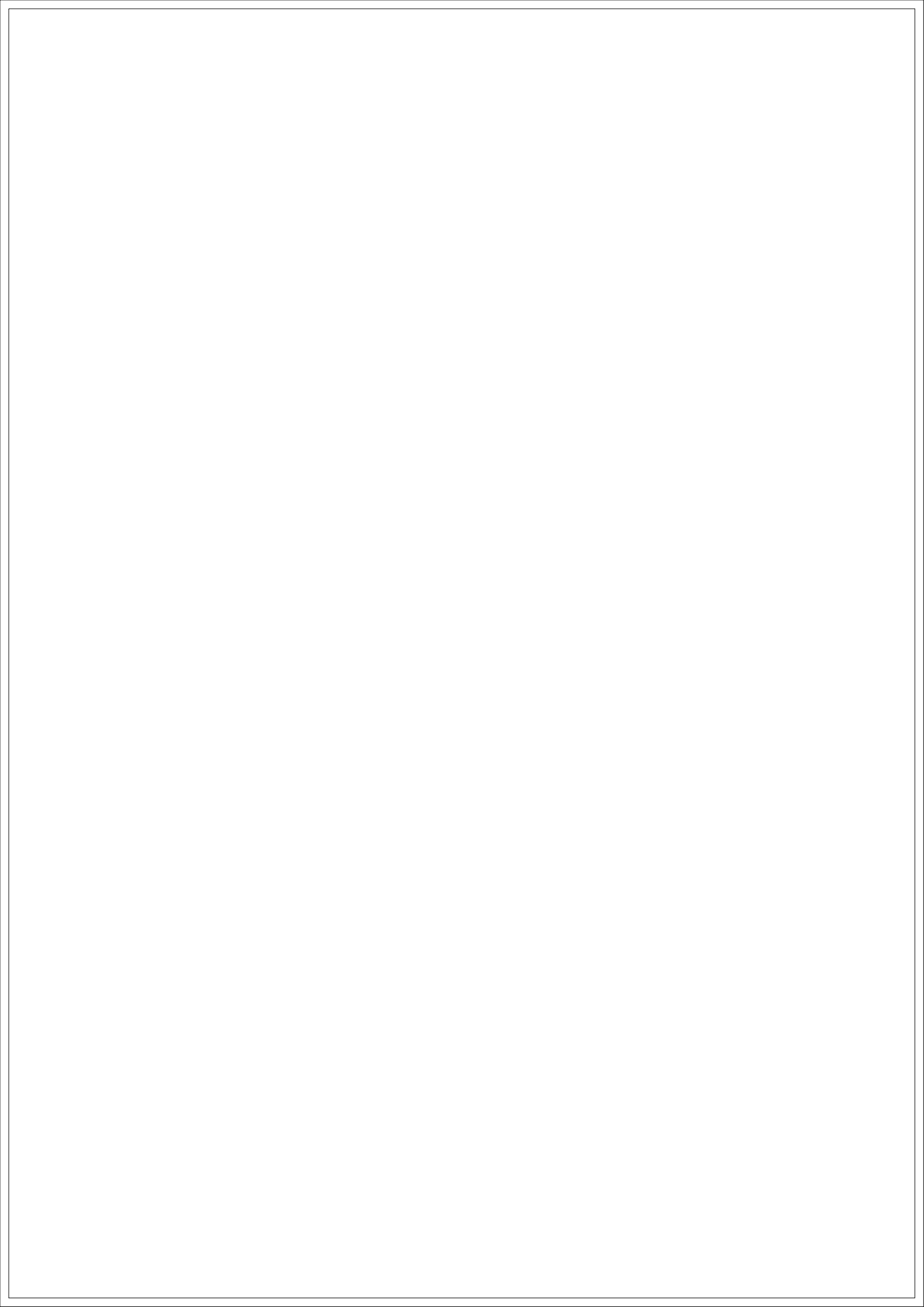

SEZIONI TRASVERSALI

Profilo longitudinale tratto 12-13

Viabilità di accesso impianto-By pass

Nota: Le canalette di deflusso delle acque meteoriche, non indicate nel presente elaborato, sono rappresentate graficamente nelle sezioni stradali tipo dell'elaborato "SR-VI-TC12_Piazzole aerogeneratori e strade di servizio - Particolari costruttivi", individuate planimetricamente nell'elaborato "SR-VI-TC13_Opere di regimazione acque superficiali - Planimetria generale" e quantificate nell'elaborato "SR-VI-RC6_Computo Metrico Estimativo opere civili".

DISEGNI DI RIFERIMENTO

TAVOLA	DESCRIZIONE
SR-VI-TC8.1	Piazzole e viabilità - Planimetria di progetto - Fase di cantiere
SR-VI-TC10	Profili longitudinali viabilità di impianto
SR-VI-TC12	Piazzole aerogeneratori e strade di servizio - Particolari costruttivi
SR-VI-TC13	Opere di regimazione acque superficiali - Planimetria generale

Sezione: 5
 Progressiva: 20.000
 Q. Progetto: 273.349

271.00

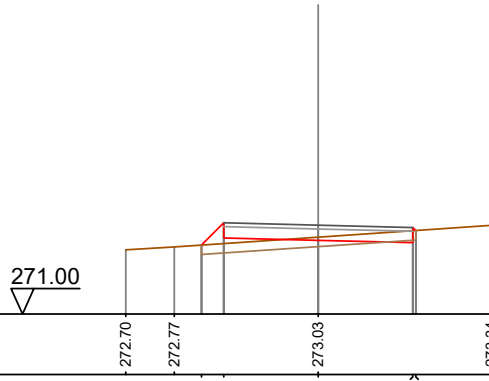

Quote Terreno	272.70	272.77	272.82	273.01	272.95	273.03	272.89	273.21	273.34
Quote Progetto			272.82	273.01	272.95	273.03	272.89	273.21	
Parziali			0.59	2.50	2.50				
Progressiva			-3.09	-2.50	0.00	0.00	2.50	2.58	
Dislivelli			0.00	0.55	-0.08	0.00	-0.32	0.00	

Sezione: 6
 Progressiva: 30.000
 Q. Progetto: 275.030

273.00

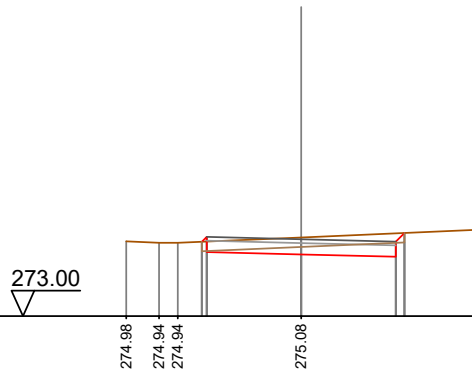

Quote Terreno	274.98	274.94	274.94	274.96	274.69	274.63	275.08	274.57	275.20	275.28
Quote Progetto				274.96	274.69	274.63	275.08	274.57	275.20	
Parziali				2.50	2.50					
Progressiva				-2.63	-2.50	0.00	0.00	2.50	2.73	
Dislivelli				-0.00	0.12	-0.45	0.00	-0.62	-0.00	

Sezione: 10
 Progressiva: 60.000
 Q. Progetto: 280.944

279.00

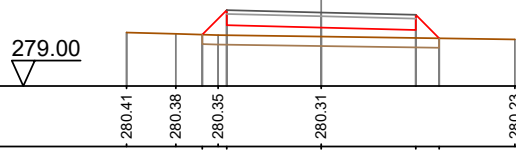

Quote Terreno		280.41		280.38		280.35		280.31		280.23
Quote Progetto			280.36		280.61		280.54		280.48	280.26
Parziali			0.65		2.50		2.50		0.62	
Progressiva			-3.15		-2.50		0.00		2.50	3.12
Dislivelli			0.00		0.66		0.24		0.21	-0.00

Sezione: 11
 Progressiva: 70.000
 Q. Progetto: 282.955

280.00

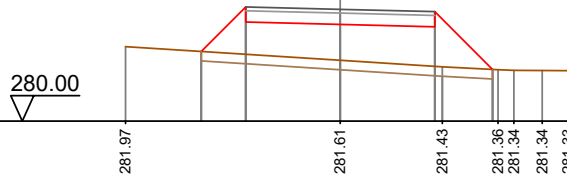

Quote Terreno		281.97				281.61		281.43		281.36	281.34	281.33
Quote Progetto			281.84		282.62		282.56		282.49	281.36	281.34	
Parziali			1.18		2.50		2.50		1.53			
Progressiva			-3.68		-2.50		0.00		2.50	4.03		
Dislivelli			0.00		1.25		0.95		1.04	0.00		

Sezione: 12
 Progressiva: 73.686
 Q. Progetto: 283.696

280.00

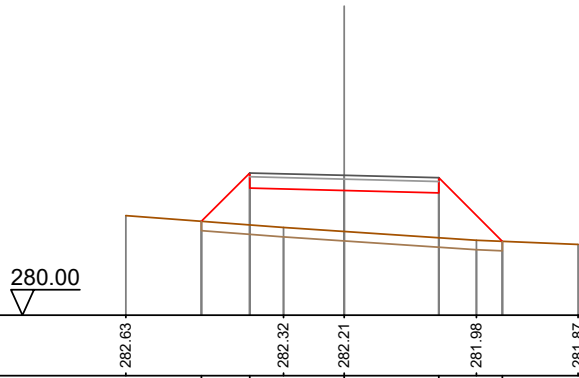

Quote Terreno		282.63			282.32		282.21		281.98		281.87
Quote Progetto			282.48		283.36		283.30		283.23		281.95
Parziali			1.28		2.50		2.50		1.68		
Progressiva			-3.78		-2.50		0.00		2.50	4.18	
Dislivelli			0.00		1.37		1.09		1.19	0.00	

Sezione: 13
 Progressiva: 80.000
 Q. Progetto: 284.966

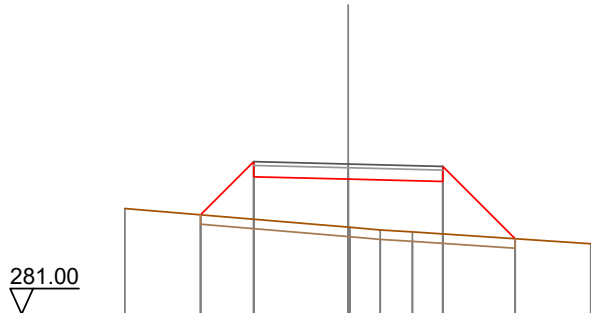

Quote Terreno		283.79		283.30	283.29	283.22	283.17		282.86
Quote Progetto			283.62	284.63	284.57	284.50		282.99	
Parziali			1.41	2.50	2.50	1.91			
Progressiva			-3.91	-2.50	0.00	2.50		4.41	
Dislivelli			0.00	1.52	1.27	1.39		-0.00	

Sezione: 14
 Progressiva: 89.179
 Q. Progetto: 286.813

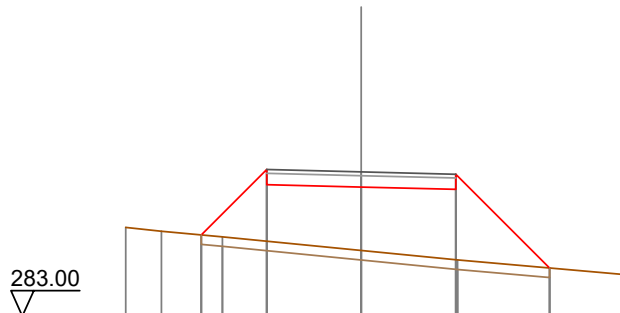

Quote Terreno		285.35	285.24	285.09		284.73	284.48		284.10
Quote Progetto			285.15	286.48	286.41	286.35	284.27		
Parziali			1.73	2.50	2.50	2.48			
Progressiva			-4.23	-2.50	0.00	2.50	4.98		
Dislivelli			-0.00	1.90	1.68	1.86	0.00		

Sezione: 15
 Progressiva: 100.000
 Q. Progetto: 288.989

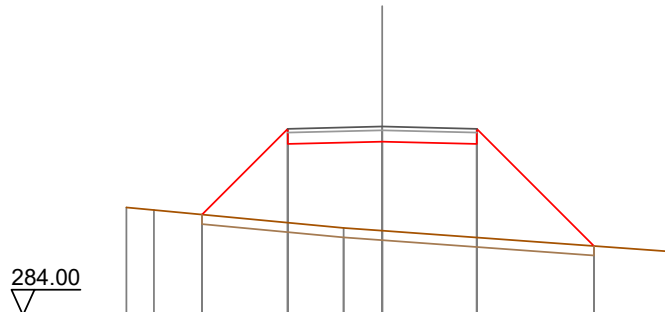

Quote Terreno		286.85	286.78		286.31	286.23		285.68
Quote Progetto			286.66	288.53	288.59	288.53	285.83	
Parziali			2.27	2.50	2.50	3.10		
Progressiva			-4.77	-2.50	0.00	2.50	5.60	
Dislivelli			0.00	2.48	2.36	2.48	0.00	

Sezione: 16
 Progressiva: 103.403
 Q. Progetto: 289.674

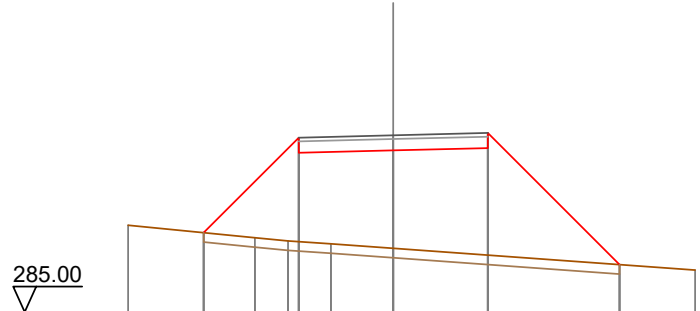

Quote Terreno		287.29		286.97	286.88	286.80	289.27	289.34		286.25		286.11
Quote Progetto			287.10		289.21		289.27	289.34		286.25		
Parziali				2.51	2.50	2.50		3.48				
Progressiva			-5.01		-2.50	0.00	2.50		5.98			
Dislivelli			0.00	2.75	2.59	2.83	0.00					

Sezione: 17
 Progressiva: 110.000
 Q. Progetto: 291.000

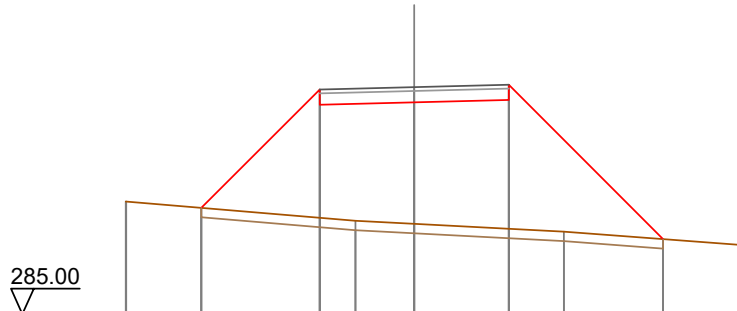

Quote Terreno		287.97		287.47	287.39		287.18		286.83
Quote Progetto			287.81	290.54	290.60	290.66		286.98	
Parziali			3.13	2.50	2.50	4.08			
Progressiva			-5.63	-2.50	0.00	2.50	6.58		
Dislivelli			0.00	3.39	3.21	3.41	0.00		

Sezione: 18
 Progressiva: 120.000
 Q. Progetto: 293.012

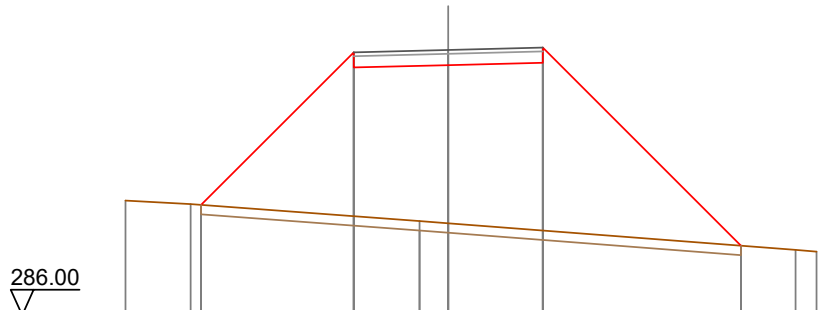

Quote Terreno		289.03	288.93		288.49	288.43		287.72	287.68
Quote Progetto			288.91	292.55	292.61	292.67		287.83	
Parziali			4.04	2.50	2.50	5.24			
Progressiva			-6.54	-2.50	0.00	2.50	7.74		
Dislivelli			0.00	4.33	4.18	4.44	0.00		

Sezione: 19
 Progressiva: 130.000
 Q. Progetto: 295.023

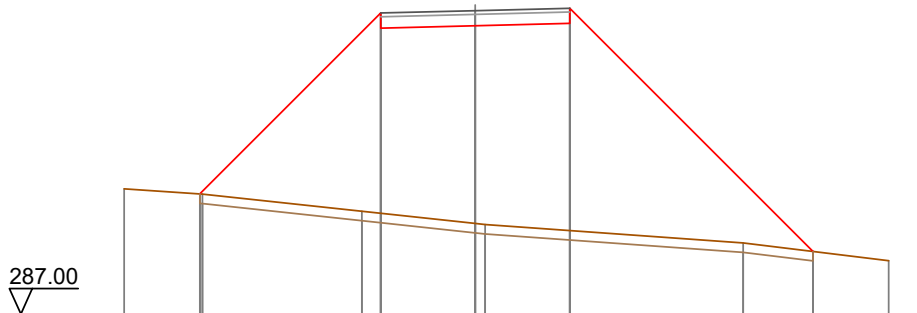

Quote Terreno		290.31	290.17	289.72	289.39	289.37	288.86	288.41
Quote Progetto		290.18	290.17	294.56	294.62	294.62	294.69	288.65
Parziali			4.78	2.50	2.50		6.43	
Progressiva		-7.28		-2.50	0.00	2.50		8.93
Dislivelli		0.00		5.30	5.23	5.48		0.00

Sezione: 20
 Progressiva: 130.435
 Q. Progetto: 295.111

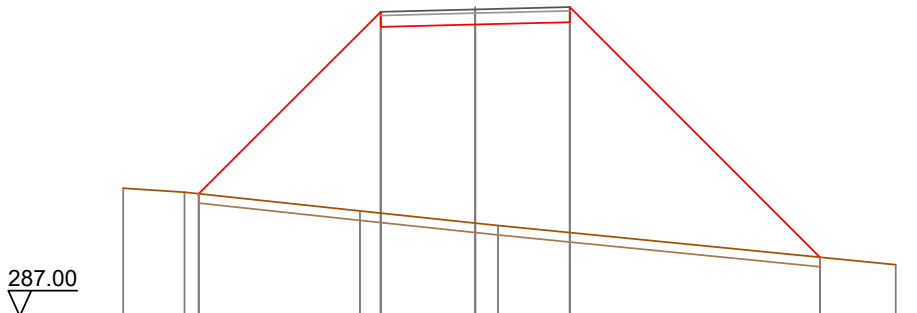

Quote Terreno		290.38	290.28	289.78	289.46	289.39		288.36
Quote Progetto		290.24	290.24	294.65	294.71	294.71	294.77	288.55
Parziali			4.81	2.50	2.50		6.62	
Progressiva		-7.31		-2.50	0.00	2.50		9.12
Dislivelli		0.00		5.32	5.25	5.57		-0.00

Sezione: 21
 Progressiva: 140.000
 Q. Progetto: 297.035

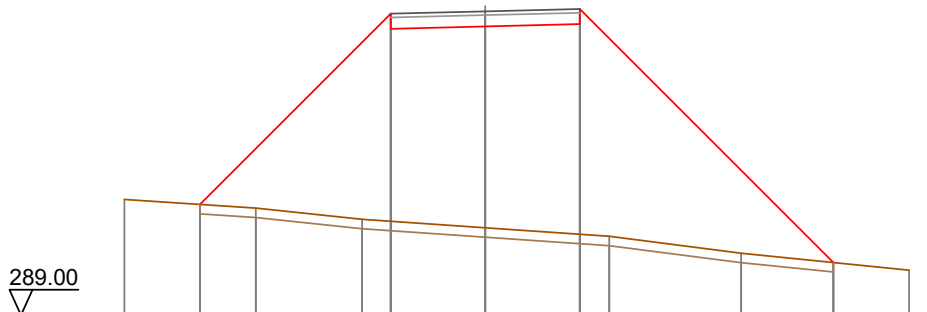

Quote Terreno		292.06	291.83	291.53	291.31	291.09	290.64	290.19
Quote Progetto		291.93	291.93	296.57	296.63	296.70	290.39	290.39
Parziali			5.04	2.50	2.50		6.71	
Progressiva		-7.54		-2.50	0.00	2.50		9.21
Dislivelli		-0.00		5.49	5.32	5.56		0.00

Sezione: 22
 Progressiva: 150.000
 Q. Progetto: 299.046

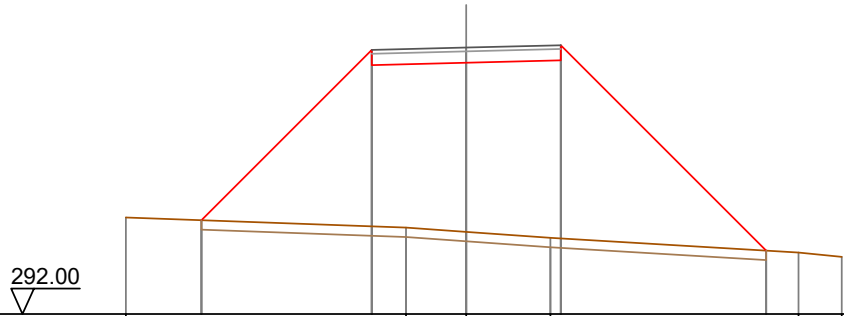

Quote Terreno		294.55			294.28		294.17		294.02		293.63	293.51
Quote Progetto			294.48		298.58		298.65		298.71		293.68	
Parziali			4.50		2.50		2.50		5.43			
Progressiva			-7.00		-2.50		0.00		2.50		7.93	
Dislivelli			0.00		4.67		4.47		4.71		-0.00	

Sezione: 23
 Progressiva: 157.466
 Q. Progetto: 300.548

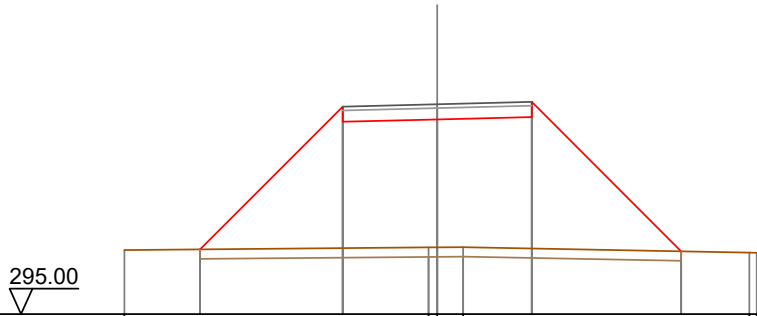

Quote Terreno		296.69			296.76		296.76		296.77		296.63	296.62
Quote Progetto			296.71		300.09		300.15		300.21		296.66	
Parziali			3.77		2.50		2.50		3.95			
Progressiva			-6.27		-2.50		0.00		2.50		6.45	
Dislivelli			0.00		3.74		3.38		3.48		0.00	

Sezione: 24
 Progressiva: 160.000
 Q. Progetto: 301.057

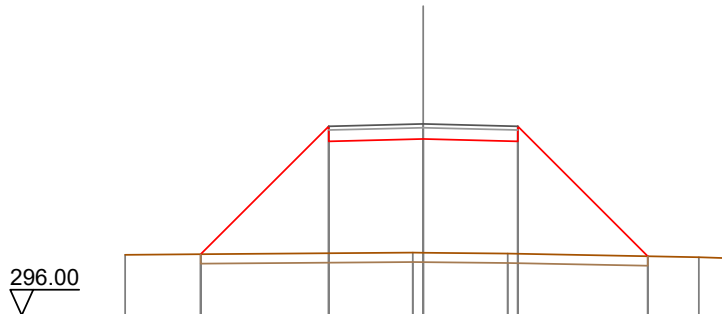

Quote Terreno		297.59			297.65		297.65		297.63		297.53	297.51
Quote Progetto			297.61		300.59		300.66		300.59		297.56	
Parziali			3.39		2.50		2.50		3.44			
Progressiva			-5.89		-2.50		0.00		2.50		5.94	
Dislivelli			0.00		3.36		3.01		2.97		-0.00	

Sezione: 25
 Progressiva: 161.969
 Q. Progetto: 301.453

297.00

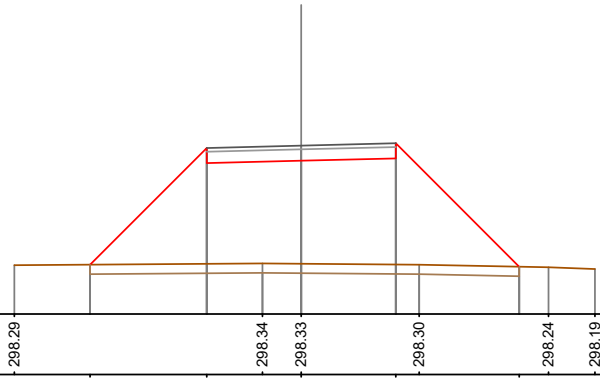

Quote Terreno	298.29		298.34	298.33	298.30	298.24	298.19
Quote Progetto		298.30	300.99	301.05	301.12	298.25	
Parziali		3.09	2.50	2.50	3.27		
Progressiva		-5.59	-2.50	0.00	2.50	5.77	
Dislivelli	0.00	3.06	2.72	2.81	0.00		

Sezione: 26
 Progressiva: 170.000
 Q. Progetto: 303.069

299.00

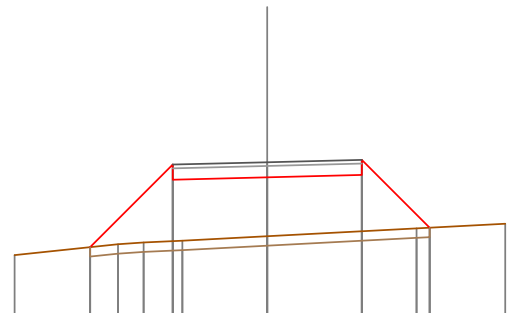

Quote Terreno	300.61	300.90	300.94	300.99	301.11	301.32	301.44
Quote Progetto		300.82	302.61	302.67	302.73	301.34	
Parziali		2.18	2.50	2.50	1.79		
Progressiva		-4.68	-2.50	0.00	2.50	4.29	
Dislivelli	0.00	2.03	1.56	1.49	0.00		

Sezione: 27
 Progressiva: 180.000
 Q. Progetto: 305.080

302.00

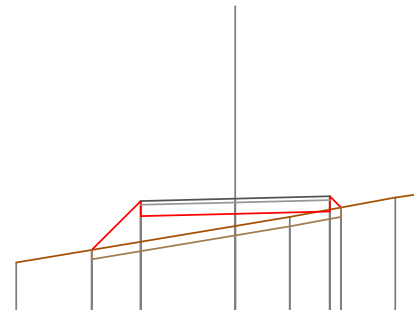

Quote Terreno	303.39		304.60	304.36	304.60	305.11	305.19
Quote Progetto		303.72	304.62	304.68	304.74	304.85	
Parziali		1.29	2.50	2.50	0.30		
Progressiva		-3.79	-2.50	0.00	2.50	2.80	
Dislivelli	0.00	1.08	0.32	-0.05	0.00		

Sezione: 28
 Progressiva: 187.025
 Q. Progetto: 306.493

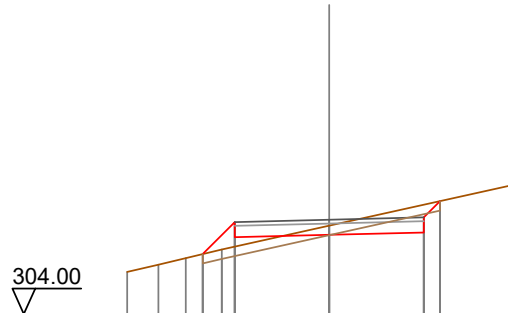

Quote Terreno	305.11	305.30	305.48	305.71	306.03	306.34	306.09	306.16	306.99	307.43
Quote Progetto				305.59	306.03		306.09		306.16	306.99
Parziali				0.84	2.50		2.50		0.43	
Progressiva				-3.34	-2.50		0.00		2.50	2.93
Dislivelli				0.00	0.65		-0.24		-0.73	0.00

Sezione: 29
 Progressiva: 190.000
 Q. Progetto: 307.090

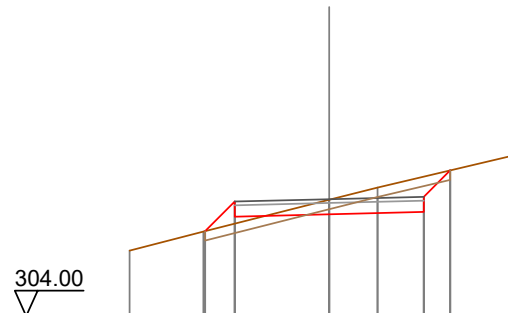

Quote Terreno	305.73	306.24	306.63	307.08	307.40	307.75	307.85	308.33
Quote Progetto		306.25	306.63	306.69	307.08	306.75	307.85	
Parziali		0.78	2.50	2.50	0.70			
Progressiva		-3.28	-2.50	0.00	2.50	3.20		
Dislivelli		0.00	0.58	-0.38	-0.93	0.00		

Sezione: 30
 Progressiva: 200.000
 Q. Progetto: 308.976

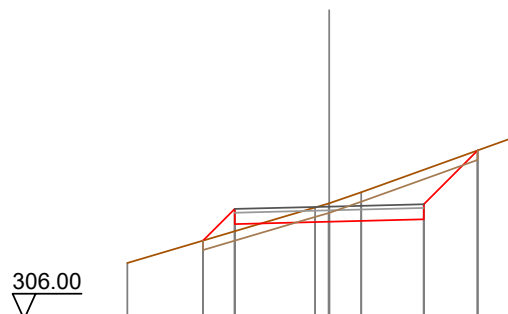

Quote Terreno	307.48	308.08	308.51	308.95	309.06	309.35	308.64	310.46	311.18
Quote Progetto		308.08	308.51	308.58	309.06	309.35	308.64	310.46	
Parziali		0.84	2.50	2.50	1.42				
Progressiva		-3.34	-2.50	0.00	2.50	3.92			
Dislivelli		0.00	0.59	-0.49	-1.31	0.00			