

PROGETTO PER LA REALIZZAZIONE DI UN IMPIANTO PER LA  
PRODUZIONE DI ENERGIA MEDIANTE LO SFRUTTAMENTO DEL VENTO  
CON IMPIANTO DI ACCUMULO NEL TERRITORIO COMUNALE DI  
TARANTO, LIZZANO E TORRICELLA IN LOC. CIRENONE (TA)  
POTENZA NOMINALE 100,2 MW

**PROGETTO DEFINITIVO - SIA**

PROGETTAZIONE E SIA

ing. Fabio PACCAPELO

ing. Andrea ANGELINI

ing. Antonella Laura GIORDANO

ing. Francesca SACCAROLA

COLLABORATORI

dr.ssa Anastasia AGNOLI

ing. Giulia MONTRONE

STUDI SPECIALISTICI

IMPIANTI ELETTRICI

ing. Roberto DI MONTE

GEOLOGIA

geol. Matteo DI CARLO

ACUSTICA

ing. Sabrina SCARAMUZZI

STUDIO FAUNISTICO

dott. nat. Fabio MASTROPASQUA

VINCA, STUDIO BOTANICO VEGETAZIONALE

E PEDO-AGRONOMICO

dr.ssa Lucia PESOLA

ARCHEOLOGIA

dr.ssa archeol. Domenica CARRASSO

INTERVENTI DI COMPENSAZIONE E VALORIZZAZIONE

arch. Gaetano FORNARELLI

arch. Andrea GIUFFRIDA

**PD.R. ELABORATI DESCRITTIVI**

**R.3 Scheda tecnica aerogeneratore**

REV. DATA DESCRIZIONE

| REV. | DATA | DESCRIZIONE |
|------|------|-------------|
|      |      |             |
|      |      |             |
|      |      |             |



Restricted  
Document no.: 0067-7060 V08  
2021-11-08

# General Description

## 4MW Platform



**Table of contents**

**1 Introduction..... 5**

**2 General Description..... 6**

**3 Mechanical Design..... 7**

3.1 Rotor..... 7

3.2 Blades..... 7

3.3 Blade Bearing ..... 8

3.4 Pitch System..... 8

3.5 Hub ..... 8

3.6 Main Shaft ..... 9

3.7 Main Bearing Housing..... 9

3.8 Main Bearing..... 9

3.9 Gearbox..... 9

3.10 Generator Bearings..... 10

3.11 High-Speed Shaft Coupling..... 10

3.12 Yaw System..... 10

3.13 Crane..... 10

3.14 Towers..... 10

3.15 Nacelle Bedplate and Cover ..... 11

3.16 Thermal Conditioning System ..... 11

3.16.1 Generator and Converter Cooling ..... 12

3.16.2 Gearbox and Hydraulic Cooling ..... 12

3.16.3 Transformer Cooling ..... 12

3.16.4 Nacelle Cooling..... 12

3.16.5 Optional Air Intake Hatches ..... 12

**4 Electrical Design..... 12**

4.1 Generator ..... 12

4.2 Converter..... 13

4.3 HV Transformer ..... 14

4.3.1 Eco-designs - IEC 50 Hz/60 Hz version ..... 14

4.4 HV Cables ..... 18

4.5 HV Switchgear ..... 19

4.5.1 IEC 50/60Hz version ..... 21

4.5.2 IEEE 60Hz version..... 22

4.6 AUX System ..... 22

4.7 Wind Sensing System..... 23

4.8 Vestas Multi Processor (VMP) Controller ..... 23

4.9 Uninterruptible Power Supply (UPS) ..... 23

**5 Turbine Protection Systems..... 24**

5.1 Braking Concept ..... 24

5.2 Short Circuit Protections ..... 25

5.3 Overspeed Protection ..... 25

5.4 Arc Detection ..... 25

5.5 Smoke Detection ..... 25

5.6 Lightning Protection of Blades, Nacelle, Hub and Tower..... 26

5.7 EMC ..... 27

5.8 Earthing ..... 27

5.9 Corrosion Protection ..... 28

**6 Safety..... 28**

6.1 Access ..... 28

6.2 Escape..... 28

6.3 Rooms/Working Areas ..... 29

6.4 Floors, Platforms, Standing, and Working Places ..... 29



|           |   |           |
|-----------|---|-----------|
| 6.5       | Service Lift.....   | 29        |
| 6.6       | Climbing Facilities.....  | 29        |
| 6.7       | Moving Parts, Guards, and Blocking Devices.....   | 29        |
| 6.8       | Lights.....   | 29        |
| 6.9       | Emergency Stop.....   | 29        |
| 6.10      | Power Disconnection.....  | 30        |
| 6.11      | Fire Protection/First Aid.....  | 30        |
| 6.12      | Warning Signs.....  | 30        |
| 6.13      | Manuals and Warnings.....   | 30        |
| <b>7</b>  | <b>Environment.....</b>   | <b>30</b> |
| 7.1       | Chemicals.....  | 30        |
| <b>8</b>  | <b>Design Codes.....</b>  | <b>30</b> |
| 8.1       | Design Codes – Structural Design.....   | 30        |
| <b>9</b>  | <b>Colours.....</b>   | <b>31</b> |
| 9.1       | Nacelle Colour.....   | 31        |
| 9.2       | Tower Colour.....   | 32        |
| 9.3       | Blade Colour.....   | 32        |
| <b>10</b> | <b>Operational Envelope and Performance Guidelines.....</b>   | <b>32</b> |
| 10.1      | Climate and Site Conditions.....  | 32        |
| 10.2      | Operational Envelope – Temperature and Altitude.....  | 32        |
| 10.3      | Operational Envelope – Temperature and Altitude.....  | 33        |
| 10.4      | Operational Envelope – Grid Connection.....   | 35        |
| 10.5      | Operational Envelope – Reactive Power Capability in 4.0 MW Mode 0.....                              | 36        |
| 10.6      | Operational Envelope – Reactive Power Capability in 4.0 MW Reactive Power Optimized Mode (QO1)..... | 37        |
| 10.7      | Operational Envelope – Reactive Power Capability in 4.2 MW Power Optimized Mode (PO1).....          | 38        |
| 10.8      | Operational Envelope – Temperature dependent Reactive Power Capability.....                         | 39        |
| 10.9      | Performance – Fault Ride Through.....   | 40        |
| 10.10     | Performance – Reactive Current Contribution.....  | 41        |
| 10.10.1   | Asymmetrical Reactive Current Contribution.....   | 41        |
| 10.11     | Performance – Multiple Voltage Dips.....  | 41        |
| 10.12     | Performance – Active and Reactive Power Control.....  | 42        |
| 10.13     | Performance – Voltage Control.....  | 42        |
| 10.14     | Performance – Frequency Control.....  | 42        |
| 10.15     | Distortion – Immunity.....  | 42        |
| 10.16     | Main Contributors to Own Consumption.....   | 42        |
| <b>11</b> | <b>Drawings.....</b>  | <b>44</b> |
| 11.1      | Structural Design – Illustration of Outer Dimensions.....   | 44        |
| 11.2      | Structural Design – Side View Drawing.....  | 44        |
| <b>12</b> | <b>General Reservations, Notes and Disclaimers.....</b>   | <b>45</b> |



**Recipient acknowledges that (i) this General Description is provided for recipient's information only, and, does not create or constitute a warranty, guarantee, promise, commitment, or other representation (Commitment) by Vestas Wind Systems or any of its affiliated or subsidiary companies (Vestas), all of which are disclaimed by Vestas and (ii) any and all Commitments by Vestas to recipient as to this general description (or any of the contents herein) are to be contained exclusively in signed written contracts between recipient and Vestas, and not within this document.**

**See general reservations, notes and disclaimers (including, section 12, p. 45) to this general description.**

## 1 Introduction

The 4MW Platform wind turbine configurations covered by this General Description are listed below with designations according to IEC61400-22.

DIBt 2012 wind classes are also listed where applicable.

Please refer to the Performance Specification for the relevant turbine variant for full wind class definition.

This General Description contains data and descriptions common among the platform variants.

The variant specific performance can be found in the Performance Specifications for the turbine variant and operational mode required.

| Turbine Type Class                 | Turbine Type   Operating Mode  |
|------------------------------------|--|
| <b>V117-4.0/4.2 MW Strong Wind</b> | V117-4.0 MW IEC IB / IEC IIA 50/60 Hz   Mode 0                               |
|                                    | V117-4.0 MW IEC IB / IEC IIA 50/60 Hz   Reactive Power Optimized Mode (QO1)  |
|                                    | V117-4.2 MW IEC S / IEC IIA 50/60 Hz   Power Optimized Mode (PO1)            |
|                                    | V117-3.8 MW IEC IB / IEC IIA 50/60 Hz   Load Optimized Mode (LO1)            |
|                                    | V117-3.6 MW IEC IB / IEC IIA+ 50/60 Hz   Load Optimized Mode (LO2)           |
| <b>V117-4.0/4.2 MW Typhoon</b>     | V117-4.0 MW IEC IB-T / IEC IIA-T 50/60 Hz   Mode 0                           |
|                                    | V117-4.0 MW IEC IB-T / IEC IIA-T 50/60 Hz   Reactive Power Optim. Mode (QO1) |
|                                    | V117-4.2 MW IEC S-T / IEC IIA-T 50/60 Hz   Power Optimized Mode (PO1)        |
|                                    | V117-3.8 MW IEC IB-T / IEC IIA-T 50/60 Hz   Load Optimized Mode (LO1)        |
|                                    | V117-3.6 MW IEC IB-T / IEC IIA+-T 50/60 Hz   Load Optimized Mode (LO2)       |
| <b>V136-4.0/4.2 MW</b>             | V136-4.0 MW IEC IIB / IEC IIIB 50/60 Hz   Mode 0                             |
|                                    | V136-4.0 MW IEC IIB / IEC IIIB 50/60 Hz   Reactive Power Optim. Mode (QO1)   |
|                                    | V136-4.2 MW IEC S / IEC IIIB 50/60 Hz   Power Optimized Mode (PO1)           |
|                                    | V136-3.8 MW IEC IIB / IEC IIIB 50/60 Hz   Load Optimized Mode (LO1)          |
|                                    | V136-3.6 MW IEC IIB / IEC IIIB 50/60 Hz   Load Optimized Mode (LO2)          |
|                                    | V136-4.0 MW DIBt S 50 Hz   Mode 0  |
|                                    | V136-4.0 MW DIBt S 50 Hz   Reactive Power Optimized Mode (QO1)               |
|                                    | V136-4.2 MW DIBt S 50 Hz   Power Optimized Mode (PO1)                        |
|                                    | V136-3.8 MW DIBt S 50 Hz   Load Optimized Mode (LO1)                         |
|                                    | V136-3.6 MW DIBt S 50 Hz   Load Optimized Mode (LO2)                         |
| <b>V150-4.0/4.2 MW</b>             | V150-4.0 MW IEC IIIB 50/60 Hz   Mode 0                                       |
|                                    | V150-4.0 MW IEC IIIB 50/60 Hz   Reactive Power Optim. Mode (QO1)             |
|                                    | V150-4.2 MW IEC S 50/60 Hz   Power Optimized Mode (PO1)                      |
|                                    | V150-3.8 MW IEC IIIB / IEC S 50/60 Hz   Load Optimized Mode (LO1)            |
|                                    | V150-3.6 MW IEC IIIB / S 50/60 Hz   Load Optimized Mode (LO2)                |
|                                    | V150-4.0 MW DIBt S 50 Hz   Mode 0  |



| Turbine Type Class              | Turbine Type   Operating Mode                                  |
|---------------------------------|--|
| <b>V150-4.0/4.2 MW (cont'd)</b> | V150-4.0 MW DIBt S 50 Hz   Reactive Power Optimized Mode (QO1) |
|                                 | V150-4.2 MW DIBt S 50 Hz   Power Optimized Mode (PO1)          |
|                                 | V150-3.8 MW DIBt S 50 Hz   Load Optimized Mode (LO1)           |
|                                 | V150-3.6 MW DIBt S 50 Hz   Load Optimized Mode (LO2)           |

*Table 1-1: 4MW Platform turbine configurations covered.*

## 2 General Description

Vestas 4MW Platform comprises a family of wind turbines sharing a common design basis.

The 4MW Platform family of wind turbines includes V105-3.45/3.6 MW, V112-3.45/3.6 MW, V117-3.45/3.6 MW, V126-3.45 MW LTq, V126-3.45/3.6 MW HTq, V136-3.45/3.6 MW, V117-4.0/4.2 MW Strong Wind, V117-4.0/4.2 MW Typhoon, V136-4.0/4.2 MW and V150-4.0/4.2 MW.

For V105-3.45/3.6 MW, V112-3.45/3.6 MW, V117-3.45/3.6 MW, V126-3.45 MW LTq, V126-3.45/3.6 MW HTq and V136-3.45/3.6 MW, please refer to General Description 0053-3707.

This General Description only applies to V117-4.0/4.2 MW Strong Wind, V117-4.0/4.2 MW Typhoon, V136-4.0/4.2 MW and V150-4.0/4.2 MW.

These turbines are pitch regulated upwind turbines with active yaw and a three-blade rotor.

The turbines covered in this General Description are equipped with rotor with diameters residing in the range 117 m to 150 m and a rated output power of 4.0 MW.

A 4.0 MW Reactive Power Optimized Mode (QO1) is available for all variants.

A 4.2 MW Power Optimized Mode (PO1) is available for all variants.

Also, a 3.8 MW Load Optimized Mode (LO1) and a 3.6 MW Load Optimized Mode (LO2) is available for all variants.

The wind turbine family utilises the OptiTip® concept and a power system based on an induction generator and full-scale converter. With these features, the wind turbine is able to operate the rotor at variable speed and thereby maintain the power output at or near rated power even in high wind speed. At low wind speed, the OptiTip® concept and the power system work together to maximise the power output by operating at the optimal rotor speed and pitch angle.

Operating the wind turbine in 4.0 MW Reactive Power Optimized Mode (QO1) is achieved by applying an extended ambient temperature derate strategy compared with 4.0 MW Mode 0 operation.





Operating the wind turbine in 4.2 MW Power Optimized Mode (PO1) is achieved by applying an extended ambient temperature derate strategy and reduced reactive power capability compared with 4.0 MW Mode 0 operation.

### 3 Mechanical Design

#### 3.1 Rotor

The wind turbine is equipped with a rotor consisting of three blades and a hub. The blades are controlled by the microprocessor pitch control system OptiTip®. Based on the prevailing wind conditions, the blades are continuously positioned to optimise the pitch angle.

| Rotor                          | V117                   | V136                 | V150                 |
|--------------------------------|------------------------|----------------------|----------------------|
| Diameter                       | 117 m                  | 136 m                | 150 m                |
| Swept Area                     | 10751 m <sup>2</sup>   | 14527 m <sup>2</sup> | 17671 m <sup>2</sup> |
| Speed, Dynamic Operation Range | 6.7-17.5               | 5.6-14.0             | 4.9-12.0             |
| Rotational Direction           | Clockwise (front view) |                      |                      |
| Orientation                    | Upwind                 |                      |                      |
| Tilt                           | 6°                     |                      |                      |
| Hub Coning                     | 4°                     | 4°                   | 5.5°                 |
| No. of Blades                  | 3                      |                      |                      |
| Aerodynamic Brakes             | Full feathering        |                      |                      |

Table 3-1: Rotor data

#### 3.2 Blades

The blades are made of carbon and fibreglass and consist of two airfoil shells bonded to a supporting beam or with embedded structure.

| Blades                    | V117   | V136  | V150  |
|---------------------------|--|---|---|
| Type Description          | Airfoil shells bonded to supporting beam                             | Prepreg or infused structural airfoil shell | Prepreg or infused structural airfoil shell |
| Blade Length              | 57.15 m  | 66.66 m                                     | 73.66 m                                     |
| Material                  | Fibreglass reinforced epoxy, carbon fibres and Solid Metal Tip (SMT) |   |   |
| Blade Connection          | Steel roots inserted   |   |   |
| Airfoils                  | High-lift profile  |   |   |
| Maximum Chord             | 4.0 m  | 4.1 m                                       | 4.2 m                                       |
| Chord at 90% blade radius | 1.1 m  | 1.2 m                                       | 1.4 m                                       |





Table 3-2: *Blades data*

### 3.3 Blade Bearing

The blade bearings allow the blades to operate at varying pitch angles.

| Blade Bearing                  |   |
|--------------------------------|---|
| Blade bearing type (V117/V136) | Double-row four-point contact ball bearings |
| Blade bearing type (V150)      | 3-rows roller bearings                      |
| Lubrication                    | Manual grease lubrication                   |

Table 3-3: *Blade bearing data*

### 3.4 Pitch System

The turbine is equipped with a pitch system for each blade and a distributor block, all located in the hub. Each pitch system is connected to the distributor block with flexible hoses. The distributor block is connected to the pipes of the hydraulic rotating transfer unit in the hub by means of three hoses (pressure line, return line and drain line).

Each pitch system consists of a hydraulic cylinder mounted to the hub and a piston rod mounted to the blade bearing via a torque arm shaft. Valves facilitating operation of the pitch cylinder are installed on a pitch block bolted directly onto the cylinder.

| Pitch System |             |
|--------------|-------------|
| Type         | Hydraulic   |
| Number       | 1 per blade |
| Range        | -10° to 95° |

Table 3-4: *Pitch system data*

| Hydraulic System |                                       |
|------------------|---------------------------------------|
| Main Pump        | Two redundant internal-gear oil pumps |
| Pressure         | 260 bar                               |
| Filtration       | 3 µm (absolute)                       |

Table 3-5: *Hydraulic system data.*

### 3.5 Hub

The hub supports the three blades and transfers the reaction loads to the main bearing and the torque to the gearbox. The hub structure also supports blade bearings and pitch cylinders.

| Hub      |                     |
|----------|---------------------|
| Type     | Cast ball shell hub |
| Material | Cast iron           |

Table 3-6: Hub data

### 3.6 Main Shaft

The main shaft transfers the reaction forces to the main bearing and the torque to the gearbox.

| Main Shaft       |                           |
|------------------|---------------------------|
| Type Description | Hollow shaft              |
| Material         | Cast iron or forged steel |

Table 3-7: Main shaft data

### 3.7 Main Bearing Housing

The main bearing housing covers the main bearing and is the first connection point for the drive train system to the bedplate.

| Main Bearing Housing |           |
|----------------------|-----------|
| Material             | Cast iron |

Table 3-8: Main bearing housing data

### 3.8 Main Bearing

The main bearing carries all thrust loads.

| Main Bearing |                                     |
|--------------|-------------------------------------|
| Type         | Double-row spherical roller bearing |
| Lubrication  | Automatic grease lubrication        |

Table 3-9: Main bearing data

### 3.9 Gearbox

The main gear converts the low-speed rotation of the rotor to high-speed generator rotation.

The disc brake is mounted on the high-speed shaft. The gearbox lubrication system is a pressure-fed system.

| Gearbox                   |  |
|---------------------------|--|
| Type                      | Planetary stages + one helical stage       |
| Gear House Material       | Cast                                       |
| Lubrication System        | Pressure oil lubrication                   |
| Backup Lubrication System | Oil sump filled from external gravity tank |
| Total Gear Oil Volume     | 1000-1500                                  |
| Oil Cleanliness Codes     | ISO 4406-/15/12                            |
| Shaft Seals               | Labyrinth                                  |

Table 3-10: Gearbox data

### 3.10 Generator Bearings

The bearings are grease lubricated and grease is supplied continuously from an automatic lubrication unit.

### 3.11 High-Speed Shaft Coupling

The coupling transmits the torque of the gearbox high-speed output shaft to the generator input shaft.

The coupling consists of two 4-link laminate packages and a fibreglass intermediate tube with two metal flanges.

The coupling is fitted to two-armed hubs on the brake disc and the generator hub.

### 3.12 Yaw System

The yaw system is an active system based on a robust pre-tensioned plain yaw-bearing concept with PETP as friction material.

| Yaw System           |  |
|----------------------|--|
| Type                 | Plain bearing system                                 |
| Material             | Forged yaw ring heat-treated.<br>Plain bearings PETP |
| Yawing Speed (50 Hz) | 0.45°/sec.   |
| Yawing Speed (60 Hz) | 0.55°/sec.   |

Table 3-11: Yaw system data

| Yaw Gear                      |                         |
|-------------------------------|-------------------------|
| Type                          | Multiple stages geared  |
| Ratio Total                   | 944:1                   |
| Rotational Speed at Full Load | 1.4 rpm at output shaft |

Table 3-12: Yaw gear data

### 3.13 Crane

The nacelle houses the internal safe working load (SWL) service crane. The crane is a single system hoist.

| Crane            |                |
|------------------|----------------|
| Lifting Capacity | Maximum 800 kg |

Table 3-13: Crane data

### 3.14 Towers

Tubular towers with flange connections, certified according to relevant type approvals, are available in different standard heights. The towers are designed with the majority of internal welded connections replaced by magnet supports to create a predominantly smooth-walled tower.



Magnets provide load support in a horizontal direction and internals, such as platforms, ladders, etc., are supported vertically (that is, in the gravitational direction) by a mechanical connection. The smooth tower design reduces the required steel thickness, rendering the tower lighter compared to one with all internals welded to the tower shells.

Available hub heights are listed in the Performance Specification for each turbine variant. Designated hub heights include a distance from the foundation section to the ground level of approximately 0.2 m depending on the thickness of the bottom flange and a distance from tower top flange to centre of the hub of 2.2 m.

| <b>Towers</b> |                             |
|---------------|-----------------------------|
| <b>Type</b>   | Cylindrical/conical tubular |

*Table 3-14: Tower structure data*

### **3.15 Nacelle Bedplate and Cover**

The nacelle cover is made of fibreglass. Hatches are positioned in the floor for lowering or hoisting equipment to the nacelle and evacuation of personnel. The roof section is equipped with wind sensor system and skylights.

The skylights can be opened from inside the nacelle to access the roof and from outside to access the nacelle. Access from the tower to the nacelle is through the yaw system.

The nacelle bedplate is in two parts and consists of a cast iron front part and a girder structure rear part. The front of the nacelle bedplate is the foundation for the drive train and transmits forces from the rotor to the tower through the yaw system. The bottom surface is machined and connected to the yaw bearing and the yaw gears are bolted to the front nacelle bedplate.

The crane girders are attached to the top structure. The lower beams of the girder structure are connected at the rear end. The rear part of the bedplate serves as the foundation for controller panels, the cooling system and transformer. The nacelle cover is installed on the nacelle bedplate.

| <b>Type Description</b> | <b>Material</b>  |
|-------------------------|------------------|
| <b>Nacelle Cover</b>    | GRP              |
| <b>Bedplate Front</b>   | Cast iron        |
| <b>Bedplate Rear</b>    | Girder structure |

*Table 3-15: Nacelle bedplate and cover data*

### **3.16 Thermal Conditioning System**

The thermal conditioning system consists of a few robust components:

- The Vestas CoolerTop<sup>®</sup> located on top of the rear end of the nacelle. The CoolerTop<sup>®</sup> is a free flow cooler, thus ensuring that there are no electrical components in the thermal conditioning system located outside the nacelle.



- The CoolerTop is available in a standard variant and an optional high temperature variant with improved cooler performance at high ambient temperatures (HT version is not available for all turbine variants. Please consult Vestas for more information).
- The CoolerTop® comes as standard in a “naked” form, with no side cover panels. Side cover panels are available as an option.
- The Liquid Cooling System, which serves the gearbox, hydraulic systems, generator and converter is driven by an electrical pumping system.
- The transformer forced air cooling comprised of an electrical fan.

### 3.16.1 Generator and Converter Cooling

The generator and converter cooling systems operate in parallel. A dynamic flow valve mounted in the generator cooling circuit divides the cooling liquid flow. The cooling liquid removes heat from the generator and converter unit using a free-air flow radiator placed on the top of the nacelle. In addition to the generator, converter unit and radiator, the circulation system includes an electrical pump and a three-way thermostatic valve.

### 3.16.2 Gearbox and Hydraulic Cooling

The gearbox and hydraulic cooling systems are coupled in parallel. A dynamic flow valve mounted in the gearbox cooling circuit divides the cooling flow. The cooling liquid removes heat from the gearbox and the hydraulic power unit through heat exchangers and a free-air flow radiator placed on the top of the nacelle.

In addition to the heat exchangers and the radiator, the circulation system includes an electrical pump and a three-way thermostatic valve.

### 3.16.3 Transformer Cooling

The transformer is equipped with forced-air cooling. The ventilator system consists of a central fan, located below the converter and an air duct leading the air to locations beneath and between the high voltage and low voltage windings of the transformer.

### 3.16.4 Nacelle Cooling

Hot air generated by mechanical and electrical equipment is dissipated from the nacelle by a fan system located in the nacelle.

### 3.16.5 Optional Air Intake Hatches

Specific air intakes in the nacelle can optionally be fitted with hatches which can be operated as a part of the thermal control strategy. In case of lost grid to the turbine, the hatches will automatically be closed.

## 4 Electrical Design

### 4.1 Generator

The generator is a three-phase asynchronous induction generator with cage rotor that is connected to the grid through a full-scale converter. The generator housing allows the circulation of cooling air within the stator and rotor.



The air-to-water heat exchange occurs in an external heat exchanger.

| Generator                               |  |
|---|--|
| Type                                    | Asynchronous with cage rotor                         |
| Rated Power [P <sub>N</sub> ]           | 4250 / 4450 kW                                       |
| Frequency [f <sub>N</sub> ]             | 0-100 Hz   |
| Voltage, Stator [U <sub>NS</sub> ]      | 3 x 800 V (at rated speed)                           |
| Number of Poles                         | 6  |
| Winding Type                            | Form with VPI (Vacuum Pressurized Impregnation)      |
| Winding Connection                      | Delta  |
| Rated rpm                               | 1450-1550 rpm  |
| Overspeed Limit Acc. to IEC (2 minutes) | 2400 rpm   |
| Generator Bearing                       | Hybrid/ceramic                                       |
| Temperature Sensors, Stator             | 3 PT100 sensors placed at hot spots and 3 as back-up |
| Temperature Sensors, Bearings           | 1 per bearing  |
| Insulation Class                        | H  |
| Enclosure                               | IP54   |

Table 4-1: Generator data

## 4.2 Converter

The converter is a full-scale converter system controlling both the generator and the power quality delivered to the grid. The converter consists of 3 machine-side converter units and 3 line-side converter units operating in parallel with a common controller.

The converter controls conversion of variable frequency AC power from the generator into fixed frequency AC power with desired active and reactive power levels (and other grid connection parameters) suitable for the grid.

The converter is located in the nacelle and has a grid side voltage rating of 720 V. The generator side voltage rating is up to 800 V dependent on generator speed.

| Converter                              |   |
|--|---|
| Rated Apparent Power [S <sub>N</sub> ] | 5100 kVA                                      |
| Rated Grid Voltage                     | 3 x 720 V                                     |
| Rated Generator Voltage                | 3 x 800 V                                     |
| Rated Grid Current                     | 4100 A (≤30°C ambient) / 4150 (≤20°C ambient) |
| Rated Generator Current                | 3600 A (≤30°C ambient) / 3650 (≤20°C ambient) |
| Enclosure                              | IP54  |



Table 4-2: Converter data

### 4.3 HV Transformer

The step-up HV transformer is located in a separate locked room in the back of the nacelle.

The transformer is a three-phase, three limb, two-winding, dry-type transformer that is self-extinguishing. The windings are delta-connected on the high-voltage side and star connected on the low voltage side.

The transformer is designed according to IEC standards, but also complying to European Eco-design regulation No 548/2014 and No 2019/1783 set by the European Commission.

The transformer supplied for countries under EU legislation will be:

- Eco-design based on Tier 1 requirements (effective in EU until 1 July 2021)<sup>1</sup>.
- Eco-design based on Tier 2 requirements (effective in EU from 1 July 2021)<sup>1</sup>.

For other countries Eco-design based on Tier 1 requirements will be supplied as default.

#### 4.3.1 Eco-designs - IEC 50 Hz/60 Hz version

| Transformer  |  |
|--|--|
| Type description   | Eco-design dry-type cast resin transformer.  |
| Basic layout   | 3 phase, 3 limb, 2 winding transformer.  |
| Applied standards  | IEC 60076-11, IEC 60076-16, IEC 61936-1, Commission Regulation No 548/2014 and Commission Regulation No 2019/1783. |
| Cooling method   | AF   |
| Rated power  | 5150 kVA   |
| Rated voltage, turbine side  |  |
| <b>U<sub>m</sub> 1.1kV</b>   | 0.720 kV   |
| Rated voltage, grid side   |  |
| <b>U<sub>m</sub> 24.0kV</b>  | 15.7-22.0 kV   |
| <b>U<sub>m</sub> 36.0kV</b>  | 22.1-33.0 kV   |
| <b>U<sub>m</sub> 40.5kV</b>  | 33.1-36.0 kV   |
| Insulation level AC / LI / LIC   |  |
| <b>U<sub>m</sub> 1.1kV</b>   | 3 <sup>2</sup> / 3 / 3 kV  |
| <b>U<sub>m</sub> 24.0kV</b>  | 50 <sup>2</sup> / 125 / 125 kV   |
| <b>U<sub>m</sub> 36.0kV</b>  | 70 <sup>2</sup> / 170 / 170 kV   |
| <b>U<sub>m</sub> 40.5kV</b>  | 80 <sup>2</sup> / 170 / 170 kV   |
| Off-circuit tap changer  | ±2 x 2.5 %   |
| Frequency  | 50 Hz / 60 Hz  |
| Vector group   | Dyn5   |
| No-load current <sup>3</sup>   | ~0.5 %   |
| Positive sequence short-circuit impedance @ rated power, reference temperature according to IEC 60076-11 <sup>4</sup>  | 9.9 %  |
| Positive sequence short-circuit resistance @ rated power, reference temperature according to IEC 60076-11 <sup>3</sup> | ~0.8 %   |





| Transformer  |                                       |
|--|---------------------------------------|
| <b>Zero sequence short-circuit impedance@ rated power, reference temperature according to IEC 60076-11 <sup>3</sup></b>  | ~8.3 %                                |
| <b>Zero sequence short-circuit resistance@ rated power, reference temperature according to IEC 60076-11 <sup>3</sup></b> | ~0.7 %                                |
| <b>No-load reactive power <sup>3</sup></b>   | ~20 kVAr                              |
| <b>Full load reactive power <sup>3</sup></b>   | ~550 kVAr                             |
| <b>Inrush peak current <sup>3</sup></b>  | 5-8 x I <sub>n</sub> A                |
| <b>Half crest time <sup>3</sup></b>  | ~ 0.6 s                               |
| <b>Sound power level</b>   | ≤ 80 dB(A)                            |
| <b>Average temperature rise at max altitude</b>  | ≤ 90 K                                |
| <b>Max altitude <sup>5</sup></b>   | 2000 m                                |
| <b>Insulation class</b>  |                                       |
| <b>LV coil</b>   | 155 (F)                               |
| <b>HV coil</b>   | 155 (F) or 180 (H)                    |
| <b>Environmental class</b>   | E2                                    |
| <b>Climatic class</b>  | C2                                    |
| <b>Fire behaviour class</b>  | F1                                    |
| <b>Corrosion class</b>   | C4                                    |
| <b>Weight</b>  | ≤11000 kg                             |
| <b>Temperature monitoring</b>  | PT100 sensors in LV windings and core |
| <b>Overvoltage protection</b>  | Surge arresters on HV terminals       |
| <b>Temporary earthing</b>  | 3 x Ø25 mm earthing ball points       |

*Table 4-3: Transformer data for Eco-designs IEC 50 Hz/60 Hz version.*

The transformer loss limits are given at rated power as combination of load loss and no-load loss which shall fulfil the Peak Efficiency Index (PEI) of the Eco-design requirements.

The maximum losses are described by the PEI limit section and stretches over a range between Loss variant 1 and Loss variant 2, see Figure 4-1 and Figure 4-2. The loss variant values are selected based on energy loss optimization with the turbine user profile hence the energy loss of transformers between Loss variant 1 and Loss variant 2 are comparable.

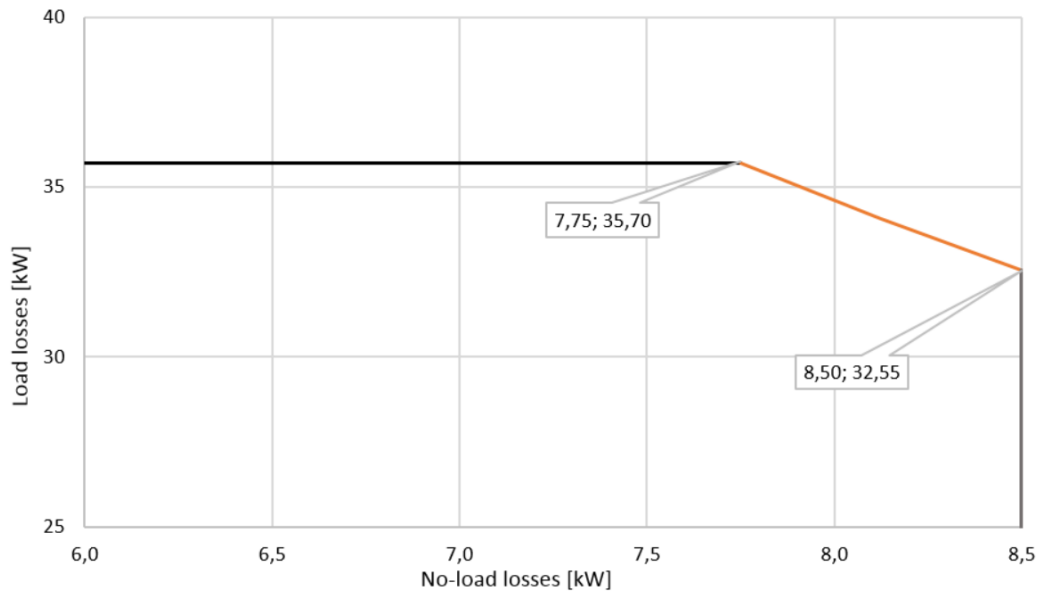

Figure 4-1 Transformer losses allowable area for Tier 1

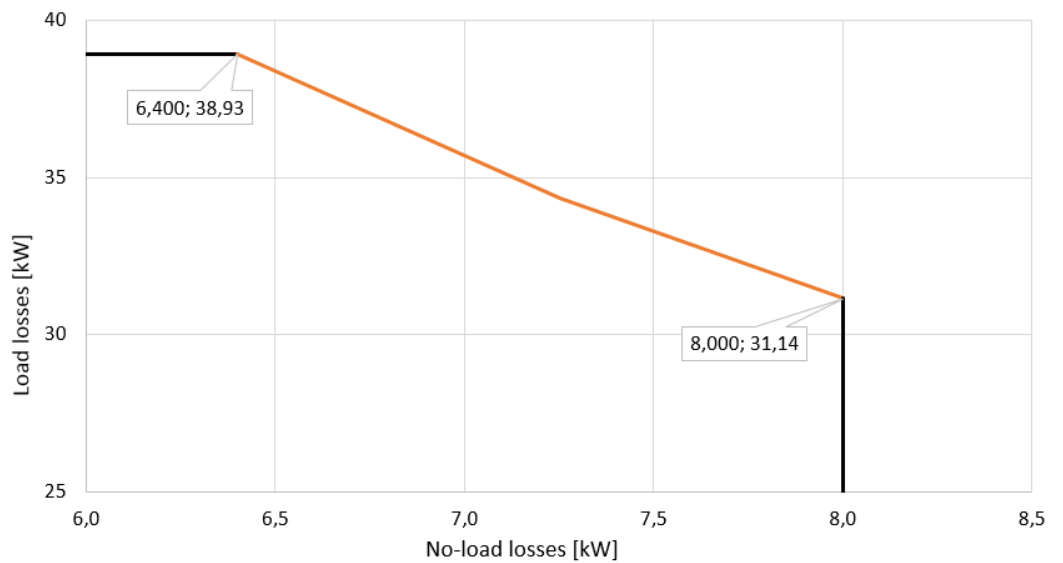

Figure 4-2 Transformer losses allowable area for Tier 2

The actual load losses vary depend on the operation mode of the turbine, hence in Table 4-4 the load losses are provided at different operation modes for the two loss variants. Table 4-4 covers both Tier 1 and Tier 2 transformer design. For further recalculation of load losses at different operation modes, refer to Figure 4-3.



| <b>Transformer losses Tier 1</b>  |                               |   |   |
|---|-------------------------------|---|---|
| <b>Peak Efficiency Index (PEI)</b>  | > 99.354                      |   |   |
| <b>Loss variant 1</b>   |                               |   |   |
| <b>No-load loss</b>   | 7.75 kW                       |   |   |
| <b>Load loss @ power, reference temperature according to IEC 60076-11</b> | <b>@5150kVA</b><br>≤ 35.70 kW | <b>@4200kVA<sup>6</sup></b><br>≤ 23.75 kW | <b>@4000kVA<sup>6</sup></b><br>≤ 21.54 kW |
| <b>Loss variant 2</b>   |                               |   |   |
| <b>No-load loss</b>   | 8.5 kW                        |   |   |
| <b>Load loss @ power, reference temperature according to IEC 60076-11</b> | <b>@5150kVA</b><br>≤ 32.55 kW | <b>@4200kVA<sup>6</sup></b><br>≤ 21.65 kW | <b>@4000kVA<sup>6</sup></b><br>≤ 19.64 kW |
| <b>Transformer losses Tier 2</b>  |                               |   |   |
| <b>Peak Efficiency Index (PEI)</b>  | > 99.387                      |   |   |
| <b>Loss variant 1</b>   |                               |   |   |
| <b>No-load loss</b>   | 6.4 kW                        |   |   |
| <b>Load loss @ power, reference temperature according to IEC 60076-11</b> | <b>@5150kVA</b><br>≤ 39.93 kW | <b>@4200kVA<sup>6</sup></b><br>≤ 25.89 kW | <b>@4000kVA<sup>6</sup></b><br>≤ 23.49 kW |
| <b>Loss variant 2</b>   |                               |   |   |
| <b>No-load loss</b>   | 8.0 kW                        |   |   |
| <b>Load loss @ power, reference temperature according to IEC 60076-11</b> | <b>@5150kVA</b><br>≤ 31.14 kW | <b>@4200kVA<sup>6</sup></b><br>≤ 20.71 kW | <b>@4000kVA<sup>6</sup></b><br>≤ 18.79 kW |

Table 4-4: Transformer losses for Eco-designs IEC 50 Hz/60 Hz version.

- NOTE**
- <sup>1</sup> The date reflects date for shipment of transformer from manufacturer.
  - <sup>2</sup> @1000m. According to IEC 60076-11, AC test voltage is altitude dependent.
  - <sup>3</sup> Based on an average of calculated values across voltages and manufacturers.
  - <sup>4</sup> Subjected to standard IEC tolerances.
  - <sup>5</sup> Transformer max altitude may be adjusted to match turbine location. For voltage class Um 40,5 kV altitude are limited to 1000m for Eco-design Tier 2.
  - <sup>6</sup> Information values based on operation mode, see Figure 4-3.



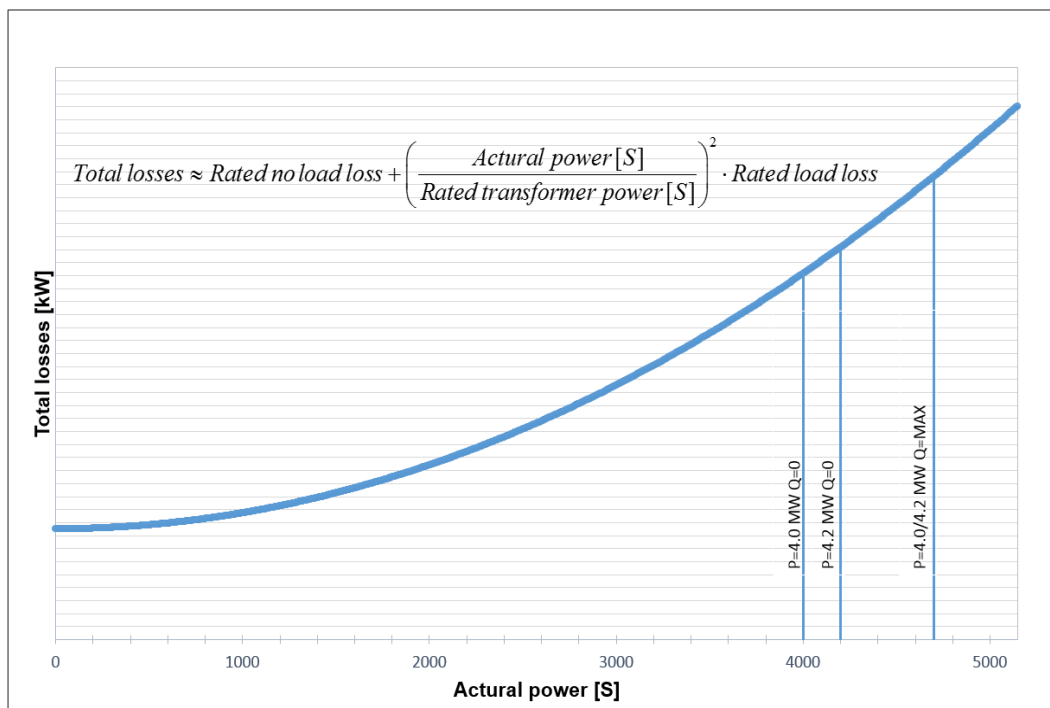

Figure 4-3: Total Losses vs. Actual Power.

#### 4.4 HV Cables

The high-voltage cable runs from the transformer in the nacelle down the tower to the HV switchgear located at the bottom of the tower. The high-voltage cable can be of two different constructions:

- A three-core, rubber-insulated, halogen-free, high-voltage cable with a three-core split earth conductor.
- A four-core, rubber-insulated, halogen-free, high-voltage cable.



| HV Cables                                     |  |
|---|--|
| <b>High-Voltage Cable Insulation Compound</b> | Improved ethylene-propylene (EP) based material-EPR or high modulus or hard grade ethylene-propylene rubber-HEPR |
| <b>Pre-terminated</b>                         | HV termination in transformer end.<br>T-Connector Type-C in switchgear end.                                      |
| <b>Maximum Voltage</b>                        | 24 kV for 19.1-22.0 kV rated voltage<br>42 kV for 22.1-36.0 kV rated voltage                                     |
| <b>Conductor Cross Sections</b>               | 3x70 / 70 mm <sup>2</sup> (Single PE core)<br>3x70 + 3x70/3 mm <sup>2</sup> (Split PE core)                      |

*Table 4-5: HV cables data*

## 4.5 HV Switchgear

A gas insulated switchgear is installed in the bottom of the tower as an integrated part of the turbine. Its controls are integrated with the turbine safety system, which monitors the condition of the switchgear and high voltage safety related devices in the turbine. This system is named 'Ready to Protect' and ensures all protection devices are operational, whenever high voltage components in the turbine are energised. To ensure that the switchgear is always ready to trip, it is equipped with redundant trip circuits consisting of an active trip coil and an undervoltage trip coil.

In case of grid outage the circuit breaker will disconnect the turbine from the grid after an adjustable time.

When grid returns, all relevant protection devices will automatically be powered up via UPS.

When all the protection devices are operational, the circuit breaker will re-close after an adjustable time. The re-close functionality can furthermore be used to implement a sequential energization of a wind park, in order to avoid simultaneous inrush currents from all turbines once grid returns after an outage.

In case the circuit breaker has tripped due to a fault detection, the circuit breaker will be blocked for re-connection until a manual reset is performed.

In order to avoid unauthorized access to the transformer room during live condition, the earthing switch of the circuit breaker, contains a trapped-key interlock system with its counterpart installed on the access door to the transformer room.

The switchgear is available in three variants with increasing features, see Table 4-6. Beside the increase in features, the switchgear can be configured depending on the number of grid cables planned to enter the individual turbine. The design of the switchgear solution is optimized such grid cables can be connected to the switchgear even before the tower is installed and still maintain its protection toward weather conditions and internal condensation due to a gas tight packing.

The switchgear is available in an IEC version and in an IEEE version. The IEEE version is however only available in the highest voltage class. The electrical parameters of the switchgear are seen in Table 4-7 for the IEC version and in Table 4-8 for the IEEE version.



| HV Switchgear  |       |            |          |
|--|-------|------------|----------|
| Variant  | Basic | Streamline | Standard |
| IEC standards  | ○     | ⊙          | ⊙        |
| IEEE standards   | ⊙     | ○          | ⊙        |
| Vacuum circuit breaker panel   | ⊙     | ⊙          | ⊙        |
| Overcurrent, short-circuit and earth fault protection                        | ⊙     | ⊙          | ⊙        |
| Disconnecter / earthing switch in circuit breaker panel                      | ⊙     | ⊙          | ⊙        |
| Voltage Presence Indicator System for circuit breaker                        | ⊙     | ⊙          | ⊙        |
| Voltage Presence Indicator System for grid cables                            | ⊙     | ⊙          | ⊙        |
| Double grid cable connection   | ⊙     | ⊙          | ⊙        |
| Triple grid cable connection   | ⊙     | ○          | ○        |
| Preconfigured relay settings   | ⊙     | ⊙          | ⊙        |
| Turbine safety system integration  | ⊙     | ⊙          | ⊙        |
| Redundant trip coil circuits   | ⊙     | ⊙          | ⊙        |
| Trip coil supervision  | ⊙     | ⊙          | ⊙        |
| Pendant remote control from outside of tower                                 | ⊙     | ⊙          | ⊙        |
| Sequential energization  | ⊙     | ⊙          | ⊙        |
| Reclose blocking function  | ⊙     | ⊙          | ⊙        |
| Heating elements   | ⊙     | ⊙          | ⊙        |
| Trapped-key interlock system for circuit breaker panel                       | ⊙     | ⊙          | ⊙        |
| Motor operation of circuit breaker   | ⊙     | ⊙          | ⊙        |
| Cable panel for grid cables (configurable)                                   | ○     | ⊙          | ⊙        |
| Switch disconnector panels for grid cables – max three panels (configurable) | ○     | ⊙          | ⊙        |
| Earthing switch for grid cables  | ○     | ⊙          | ⊙        |
| Internal arc classification  | ○     | ⊙          | ⊙        |
| Supervision on MCB's   | ○     | ⊙          | ⊙        |
| Motor operation of switch disconnector                                       | ○     | ○          | ⊙        |
| SCADA operation and feedback of circuit breaker                              | ○     | ○          | ⊙        |
| SCADA operation and feedback of switch disconnector                          | ○     | ○          | ⊙        |

Table 4-6: HV switchgear variants and features



### 4.5.1 IEC 50/60Hz version

| <b>HV Switchgear</b>  |  |
|---|--|
| <b>Type description</b>   | Gas Insulated Switchgear   |
| <b>Applied standards</b>  | IEC 62271-103<br>IEC 62271-1, 62271-100, 62271-102, 62271-200, IEC 60694 |
| <b>Insulation medium</b>  | SF <sub>6</sub>  |
| <b>Rated voltage</b>  |  |
|   | <b>U<sub>r</sub> 24.0kV</b> 15.7-22.0 kV                                 |
|   | <b>U<sub>r</sub> 36.0kV</b> 22.1-33.0 kV                                 |
|   | <b>U<sub>r</sub> 40.5kV</b> 33.1-36.0 kV                                 |
| <b>Rated insulation level AC // LI<br/>Common value / across isolation<br/>distance</b> |  |
|   | <b>U<sub>r</sub> 24.0kV</b> 50 / 60 // 125 / 145 kV                      |
|   | <b>U<sub>r</sub> 36.0kV</b> 70 / 80 // 170 / 195 kV                      |
|   | <b>U<sub>r</sub> 40.5kV</b> 85 / 90 // 185 / 215 kV                      |
| <b>Rated frequency</b>  | 50 Hz / 60 Hz  |
| <b>Rated normal current</b>   | 630 A  |
| <b>Rated Short-time withstand current</b>   |  |
|   | <b>U<sub>r</sub> 24.0kV</b> 20 kA  |
|   | <b>U<sub>r</sub> 36.0kV</b> 25 kA  |
|   | <b>U<sub>r</sub> 40.5kV</b> 25 kA  |
| <b>Rated peak withstand current<br/>50 / 60 Hz</b>                                      |  |
|   | <b>U<sub>r</sub> 24.0kV</b> 50 / 52 kA                                   |
|   | <b>U<sub>r</sub> 36.0kV</b> 62.5 / 65 kA                                 |
|   | <b>U<sub>r</sub> 40.5kV</b> 62.5 / 65 kA                                 |
| <b>Rated duration of short-circuit</b>  | 1 s  |
| <b>Internal arc classification (option)</b>   |  |
|   | <b>U<sub>r</sub> 24.0kV</b> IAC A FLR 20 kA, 1 s                         |
|   | <b>U<sub>r</sub> 36.0kV</b> IAC A FLR 25 kA, 1 s                         |
|   | <b>U<sub>r</sub> 40.5kV</b> IAC A FLR 25 kA, 1 s                         |
| <b>Connection interface</b>   | Outside cone plug-in bushings, IEC interface C1.                         |
| <b>Loss of service continuity category</b>  | LSC2   |
| <b>Ingress protection</b>   |  |
|   | <b>Gas tank</b> IP 65  |
|   | <b>Enclosure</b> IP 2X   |
|   | <b>LV cabinet</b> IP 3X  |
| <b>Corrosion class</b>  | C3   |

Table 4-7: HV switchgear data for IEC version



### 4.5.2 IEEE 60Hz version

| HV Switchgear                        |   |
|--------------------------------------|---|
| Type description                     | Gas Insulated Switchgear  |
| Applied standards                    | IEEE 37.20.3, IEEE C37.20.4, IEC 62271-200, ISO 12944.                  |
| Insulation medium                    | SF <sub>6</sub>   |
| Rated voltage                        |   |
| <b>U<sub>r</sub> 38.0kV</b>          | 22.1-36.0 kV  |
| Rated insulation level AC / LI       | 70 / 150 kV   |
| Rated frequency                      | 60 Hz   |
| Rated normal current                 | 600 A   |
| Rated Short-time withstand current   | 25 kA   |
| Rated peak withstand current         | 65 kA   |
| Rated duration of short-circuit      | 1 s   |
| Internal arc classification (option) | IAC A FLR 25 kA, 1 s  |
| Connection interface grid cables     | Outside cone plug-in bushings, IEEE 386 interface type deadbreak, 600A. |
| Ingress protection                   |   |
| <b>Gas tank</b>                      | NEMA 4X / IP 65   |
| <b>Enclosure</b>                     | NEMA 2 / IP 2X  |
| <b>LV cabinet</b>                    | NEMA 2 / IP 3X  |
| Corrosion class                      | C3  |

Table 4-8: HV switchgear data for IEEE version

### 4.6 AUX System

The AUX system is supplied from a separate 650/400/230 V transformer located in the nacelle inside the converter cabinet. All motors, pumps, fans and heaters are supplied from this system.

230 V consumers are generally supplied from a 400/230 V transformer located in the tower base. Internal heating and ventilation of cabinets as well as specific option 230 V consumers are supplied from the auxiliary transformer in the converter cabinet.

| Power Sockets                        |  |
|--------------------------------------|--|
| Single Phase (Nacelle)               | 230 V (16 A) (standard)<br>110 V (16 A) (option)<br>2 x 55 V (16 A) (option) |
| Single Phase (Tower Platforms)       | 230 V (10 A) (standard)<br>110 V (16 A) (option)<br>2 x 55 V (16 A) (option) |
| Three Phase (Nacelle and Tower Base) | 3 x 400 V (16 A)   |

Table 4-9: AUX system data

## 4.7 Wind Sensing System

The turbine is equipped with a wind sensing system which can provide the wind speed and wind direction in all weather conditions. It consists of at least one wind sensor combined with different estimators which gives an estimate of the wind in the entire rotor area.

## 4.8 Vestas Multi Processor (VMP) Controller

The turbine is controlled and monitored by the VMP8000 control system.

VMP8000 is a multiprocessor control system comprised of main controller, distributed control nodes, distributed IO nodes and ethernet switches and other network equipment. The main controller is placed in the tower bottom of the turbine. It runs the control algorithms of the turbine, as well as all IO communication.

The communications network is a time triggered Ethernet network (TTEthernet).

The VMP8000 control system serves the following main functions:

- Monitoring and supervision of overall operation.
- Synchronizing of the generator to the grid during connection sequence.
- Operating the wind turbine during various fault situations.
- Automatic yawing of the nacelle.
- OptiTip<sup>®</sup> - blade pitch control.
- Reactive power control and variable speed operation.
- Noise emission control.
- Monitoring of ambient conditions.
- Monitoring of the grid.
- Monitoring of the smoke detection system.

## 4.9 Uninterruptible Power Supply (UPS)

During grid outage, an UPS system will ensure power supply for specific components.

1. 230V AC UPS for all power backup to nacelle and hub control systems
2. 24V DC UPS for power backup to tower base control systems and ready to protect.
3. 230V AC UPS for power backup to internal lights in tower, nacelle and hub.

| Backup Time                                | Standard | Optional            |
|--|----------|---------------------|
| Control System*<br>(230V AC and 24VDC UPS) | 30 min   | Up to 19.5 hours ** |
| Ready to protect<br>(24V DC UPS)           | 7 days   | 80 days***          |

Table 4-10: UPS data

| Light Box       |          |            |
|-----------------|----------|------------|
| Backup Time     | Standard | Optional   |
| Internal Lights | 30 min   | 60 min**** |

Table 4-11: UPS data

\*The control system includes: the turbine controller (VMP8000), HV switchgear functions, and remote control system.

\*\*Requires upgrade of the 230V UPS for control system with extra batteries.

\*\*\*Requires upgrade of the 24V DC UPS with extra battery panel.

\*\*\*\*Requires upgrade of the 230V UPS for internal light with extra batteries.

**NOTE** For alternative backup times, consult Vestas.

## 5 Turbine Protection Systems

### 5.1 Braking Concept

The main brake on the turbine is aerodynamic. Stopping the turbine is done by full feathering the three blades (individually turning each blade). Each blade has a hydraulic accumulator to supply power for turning the blade.

In addition, there is a mechanical disc brake on the high-speed shaft of the gearbox with a dedicated hydraulic system. The mechanical brake is only used as a parking brake and when activating the emergency stop buttons.



## 5.2 Short Circuit Protections

| Breakers                              | Breaker for Aux. Power.<br>Back-up CB (T5V-HA 400A TMA 800V) and aux. power CB (T4V-HA 125A TMA 800V) tested in coordination | Breaker 1 for Converter Modules<br>MTZ2 1600A<br>1000 V | Breaker 2 for Converter Modules<br>MTZ2 3200A<br>1000 V |
|---------------------------------------|--|---|---|
| Breaking Capacity $I_{cu}$ , $I_{cs}$ | 75 kA rms @ max 840 V<br>$I_{cs} = 100\%$  | 66 kA rms @ max 1000 V<br>$I_{cs} = 100\%$              | 66 kA rms @ max 1000 V<br>$I_{cs} = 100\%$              |
| Making Capacity $I_{cm}$              | 166 kA peak @ max 840 V  | 145 kA peak @ max 1000 V                                | 145 kA peak @ max 1000 V                                |

Table 5-1: Short circuit protection data

## 5.3 Overspeed Protection

The generator rpm and the main shaft rpm are registered by inductive sensors and calculated by the wind turbine controller to protect against overspeed and rotating errors.

The safety-related partition of the VMP8000 control system monitors the rotor rpm. In case of an overspeed situation, the safety-related partition of the VMP8000 control system activates the emergency feathered position (full feathering) of the three blades independently of the non-safety related partition of VMP8000 control system.

| Overspeed Protection           |                                      |
|--------------------------------|--------------------------------------|
| Sensors Type                   | Inductive                            |
| Trip Level (variant dependent) | 12.0-17.5 rpm / 2000 (generator rpm) |

Table 5-2: Overspeed protection data

## 5.4 Arc Detection

The turbine is equipped with an Arc Detection system including multiple optical arc detection sensors placed in the HV transformer compartment and the converter cabinet. The Arc Detection system is connected to the turbine safety system ensuring immediate opening of the HV switchgear if an arc is detected.

## 5.5 Smoke Detection

The turbine is equipped with a Smoke Detection system including multiple smoke detection sensors placed in the nacelle (above the disc brake), in the transformer compartment, in main electrical cabinets in the nacelle and above the HV switchgear in the tower base. The Smoke Detection system is connected to the turbine safety system ensuring immediate opening of the HV switchgear if smoke is detected.

## 5.6 Lightning Protection of Blades, Nacelle, Hub and Tower

The Lightning Protection System (LPS) helps protect the wind turbine against the physical damage caused by lightning strikes. The LPS consists of five main parts:

- Lightning receptors. All lightning receptor surfaces on the blades are unpainted, excluding the Solid Metal Tips (SMT).
- Down conducting system (a system to conduct the lightning current down through the wind turbine to help avoid or minimise damage to the LPS itself or other parts of the wind turbine).
- Protection against overvoltage and overcurrent.
- Shielding against magnetic and electrical fields.
- Earthing system.

V136 blades and V150 blades:

| Lightning Protection Design Parameters |               |         | Protection Level I |
|--|---------------|---------|--------------------|
| <b>Current Peak Value</b>              | $i_{max}$     | [kA]    | 200                |
| <b>Impulse Charge</b>                  | $Q_{impulse}$ | [C]     | 100                |
| <b>Long Duration Charge</b>            | $Q_{long}$    | [C]     | 200                |
| <b>Total Charge</b>                    | $Q_{total}$   | [C]     | 300                |
| <b>Specific Energy</b>                 | W/R           | [MJ/Ω]  | 10                 |
| <b>Average Steepness</b>               | di/dt         | [kA/μs] | 200                |

Table 5-3: Lightning protection design parameters (IEC)

Hub/Nacelle/Tower/Foundation and V117 blades:

| Lightning Protection Design Parameters |               |         | Protection Level I |
|--|---------------|---------|--------------------|
| <b>Current Peak Value</b>              | $i_{max}$     | [kA]    | 200                |
| <b>Impulse Charge</b>                  | $Q_{impulse}$ | [C]     | 200                |
| <b>Long Duration Charge</b>            | $Q_{long}$    | [C]     | 600                |
| <b>Total Charge</b>                    | $Q_{total}$   | [C]     | 800                |
| <b>Specific Energy</b>                 | W/R           | [MJ/Ω]  | 20                 |
| <b>Average Steepness</b>               | di/dt         | [kA/μs] | 200                |

Table 5-4: Lightning protection design parameters (IEC & JIS)

**NOTE** The Lightning Protection System is designed according to IEC and JIS standards (see section 8 Design Codes, p. 28).

## 5.7 EMC

The turbine and related equipment fulfils the EU Electromagnetic Compatibility (EMC) legislation:

- DIRECTIVE 2014/30/EU OF THE EUROPEAN PARLIAMENT AND OF THE COUNCIL of 26 February 2014 on the harmonisation of the laws of the Member States relating to electromagnetic compatibility.

## 5.8 Earthing

The Vestas Earthing System consists of a number of individual earthing electrodes interconnected as one joint earthing system.

The Vestas Earthing System includes the TN-system and the Lightning Protection System for each wind turbine. It works as an earthing system for the medium voltage distribution system within the wind farm.

The Vestas Earthing System is adapted for the different types of turbine foundations. A separate set of documents describe the earthing system in detail, depending on the type of foundation.

In terms of lightning protection of the wind turbine, Vestas has no separate requirements for a certain minimum resistance to remote earth (measured in ohms) for this system. The earthing for the lightning protection system is based on the design and construction of the Vestas Earthing System.

A primary part of the Vestas Earthing System is the main earth bonding bar placed where all cables enter the wind turbine. All earthing electrodes are connected to this main earth bonding bar. Additionally, equipotential connections are made to all cables entering or leaving the wind turbine.

Requirements in the Vestas Earthing System specifications and work descriptions are minimum requirements from Vestas and IEC. Local and national requirements, as well as project requirements, may require additional measures.

## 5.9 Corrosion Protection

Classification of corrosion protection is according to ISO 12944-2.

| Corrosion Protection | External Areas | Internal Areas |
|----------------------|----------------|----------------|
| Nacelle              | C5             | C3             |
| Hub                  | C5             | C3             |
| Tower                | C5             | C3             |

Table 5-5: Corrosion protection data for nacelle, hub, and tower

## 6 Safety

The safety specifications in this section provide limited general information about the safety features of the turbine and are not a substitute for Buyer and its agents taking all appropriate safety precautions, including but not limited to (a) complying with all applicable safety, operation, maintenance, and service agreements, instructions, and requirements, (b) complying with all safety-related laws, regulations, and ordinances, and (c) conducting all appropriate safety training and education.

### 6.1 Access

Access to the turbine from the outside is through a door located at the entrance platform approximately 3 meter above ground level. The door is equipped with a lock. Access to the top platform in the tower is by a ladder or service lift. Access to the nacelle from the top platform is by ladder. Access to the transformer room in the nacelle is controlled with a lock. Unauthorised access to electrical switchboards and power panels in the turbine is prohibited according to IEC 60204-1 2006.

### 6.2 Escape

In addition to the normal access routes, alternative escape routes from the nacelle are through the crane hatch, from the spinner by opening the nose cone, or from the roof of the nacelle. Rescue equipment is placed in the nacelle.





The hatch in the roof can be opened from both the inside and outside. Escape from the service lift is by ladder.

An emergency response plan, placed in the turbine, describes evacuation and escape routes.

### **6.3 Rooms/Working Areas**

The tower and nacelle are equipped with power sockets for electrical tools for service and maintenance of the turbine.

### **6.4 Floors, Platforms, Standing, and Working Places**

All floors have anti-slip surfaces.

There is one floor per tower section.

Rest platforms are provided at intervals of 9 metres along the tower ladder between platforms.

Foot supports are placed in the turbine for maintenance and service purposes.

### **6.5 Service Lift**

The turbine is delivered with a service lift installed as an option.

### **6.6 Climbing Facilities**

The tower ladder is equipped with a fall arrest system, either a rail system or a wire.

The service areas in the turbines are equipped with anchor points. The anchor point may be used for work positioning, fall restraint, fall arrest and to attach a descent device to perform rescue or escape from the turbine.

Anchor points are coloured yellow and are tested to 22.5 kN.

### **6.7 Moving Parts, Guards, and Blocking Devices**

All moving parts in the nacelle are shielded.

The turbine is equipped with a rotor lock to block the rotor and drive train.

Blocking the pitch of the cylinder can be done with mechanical tools in the hub.

### **6.8 Lights**

The turbine is equipped with lights in the tower, nacelle and hub.

There is emergency light in case of the loss of electrical power.

### **6.9 Emergency Stop**

There are emergency stop buttons in the nacelle, hub and bottom of the tower.

## 6.10 Power Disconnection

The turbine is equipped with breakers to allow for disconnection from all power sources during inspection or maintenance. The switches are marked with signs and are located in the nacelle and bottom of the tower.

## 6.11 Fire Protection/First Aid

A handheld 5-6 kg CO<sub>2</sub> fire extinguisher, first aid kit and fire blanket are required to be located in the nacelle during service and maintenance.

- A handheld 5-6 kg CO<sub>2</sub> fire extinguisher is required only during service and maintenance activities, unless a permanently mounted fire extinguisher located in the nacelle is mandatorily required by authorities.
- First aid kits are required only during service and maintenance activities.
- Fire blankets are required only during non-electrical hot work activities.

## 6.12 Warning Signs

Warning signs placed inside or on the turbine must be reviewed before operating or servicing the turbine.

## 6.13 Manuals and Warnings

The Vestas Corporate OH&S Manual and manuals for operation, maintenance and service of the turbine provide additional safety rules and information for operating, servicing or maintaining the turbine.

## 7 Environment

### 7.1 Chemicals

Chemicals used in the turbine are evaluated according to the Vestas Wind Systems A/S Environmental System certified according to ISO 14001:2015. The following chemicals are used in the turbine:

- Anti-freeze to help prevent the cooling system from freezing.
- Gear oil for lubricating the gearbox.
- Hydraulic oil to pitch the blades and operate the brake.
- Grease to lubricate bearings.
- Various cleaning agents and chemicals for maintenance of the turbine.

## 8 Design Codes

### 8.1 Design Codes – Structural Design

The turbine design has been developed and tested with regard to, but not limited to, the following main standards:

| Design Codes           |                                   |
|------------------------|-----------------------------------|
| <b>Nacelle and Hub</b> | IEC 61400-1 Edition 3<br>EN 50308 |



| Design Codes  |   |
|---|---|
| <b>Tower</b>  | IEC 61400-1 Edition 3<br>Eurocode 3   |
| <b>Blades</b>   | DNV-OS-J102<br>IEC 1024-1<br>IEC 60721-2-4<br>IEC 61400 (Part 1, 12 and 23)<br>IEC WT 01 IEC<br>DEFU R25<br>ISO 2813<br>DS/EN ISO 12944-2 |
| <b>Gearbox</b>  | IEC 61400-4   |
| <b>Generator</b>  | IEC 60034   |
| <b>Transformer</b>  | IEC 60076-11, IEC 60076-16,<br>CENELEC HD637 S1   |
| <b>Lightning Protection</b>   | IEC 62305-1: 2006<br>IEC 62305-3: 2006<br>IEC 62305-4: 2006<br>IEC 61400-24:2010<br>JIS C 1400-24 2014                                    |
| <b>Rotating Electrical Machines</b>                                     | IEC 34  |
| <b>Safety of Machinery,<br/>Safety-related Parts of Control Systems</b> | IEC 13849-1   |
| <b>Safety of Machinery – Electrical<br/>Equipment of Machines</b>       | IEC 60204-1   |

Table 8-1: Design codes

## 9 Colours

### 9.1 Nacelle Colour

| Colour of Vestas Nacelles      |                       |
|--------------------------------|-----------------------|
| <b>Standard Nacelle Colour</b> | RAL 7035 (light grey) |
| <b>Standard Logo</b>           | Vestas                |

Table 9-1: Colour, nacelle



## 9.2 Tower Colour

| Colour of Vestas Tower Section |                       |                        |
|--------------------------------|-----------------------|------------------------|
|                                | External:             | Internal:              |
| <b>Standard Tower Colour</b>   | RAL 7035 (light grey) | RAL 9001 (cream white) |

Table 9-2: Colour, tower

## 9.3 Blade Colour

| Blade Colour                   |   |
|--------------------------------|---|
| <b>Standard Blade Colour</b>   | RAL 7035 (light grey). All lightning receptor surfaces on the blades are unpainted, excluding the Solid Metal Tips (SMT). |
| <b>Tip-End Colour Variants</b> | RAL 2009 (traffic orange), RAL 3020 (traffic red)   |
| <b>Gloss</b>                   | < 30% DS/EN ISO 2813  |

Table 9-3: Colour, blades

## 10 Operational Envelope and Performance Guidelines

Actual climate and site conditions have many variables and should be considered in evaluating actual turbine performance. The design and operating parameters set forth in this section do not constitute warranties, guarantees, or representations as to turbine performance at actual sites.

### 10.1 Climate and Site Conditions

Values refer to hub height:

| Extreme Design Parameters  |               |
|--|---------------|
| Wind Climate   | All           |
| <b>Ambient Temperature Interval (Standard Temperature Turbine)</b> | -40° to +50°C |

Table 10-1: Extreme design parameters

### 10.2 Operational Envelope – Temperature and Altitude

Values below refer to hub height and are determined by the sensors and control system of the turbine.

| Operational Envelope – Temperature  |               |
|---|---------------|
| <b>Ambient Temperature Interval (V117 and V136 Standard Turbine)</b>        | -20° to +45°C |
| <b>Ambient Temperature Interval (V117 and V136 Low Temperature Turbine)</b> | -30° to +45°C |



| Operational Envelope – Temperature                      |               |
|---|---------------|
| Ambient Temperature Interval<br>(V150 Standard Turbine) | -30° to +45°C |

Table 10-2: Operational envelope – temperature

**NOTE** The wind turbine will stop producing power at ambient temperatures above 45°C. For the low temperature options of the wind turbine, consult Vestas.

The turbine is designed for use at altitudes up to 1000 m above sea level as standard and optional up to 2000 m above sea level.

### 10.3 Operational Envelope – Temperature and Altitude

The turbine comes in two cooler top configurations with different performance as function of temperature. Figure 10-1 illustrate performance for standard cooler top and Figure 10-2 illustrate performance for high temperature cooler top. (HT version is not available for all turbine variants. Please consult Vestas for more information).

The values in the graphs refer to hub height and are determined by the sensors and control system of the turbine. At ambient temperatures above the thresholds shown in the figures the turbine will maintain derated production. The derate values depend of the altitude of the turbine.

The graphs show the derate curve for PO1. Mode 0, LO1 and LO2 will follow the same derate curve, but with a nominal power at respectively 4.0MW, 3.8MW and 3.6MW.



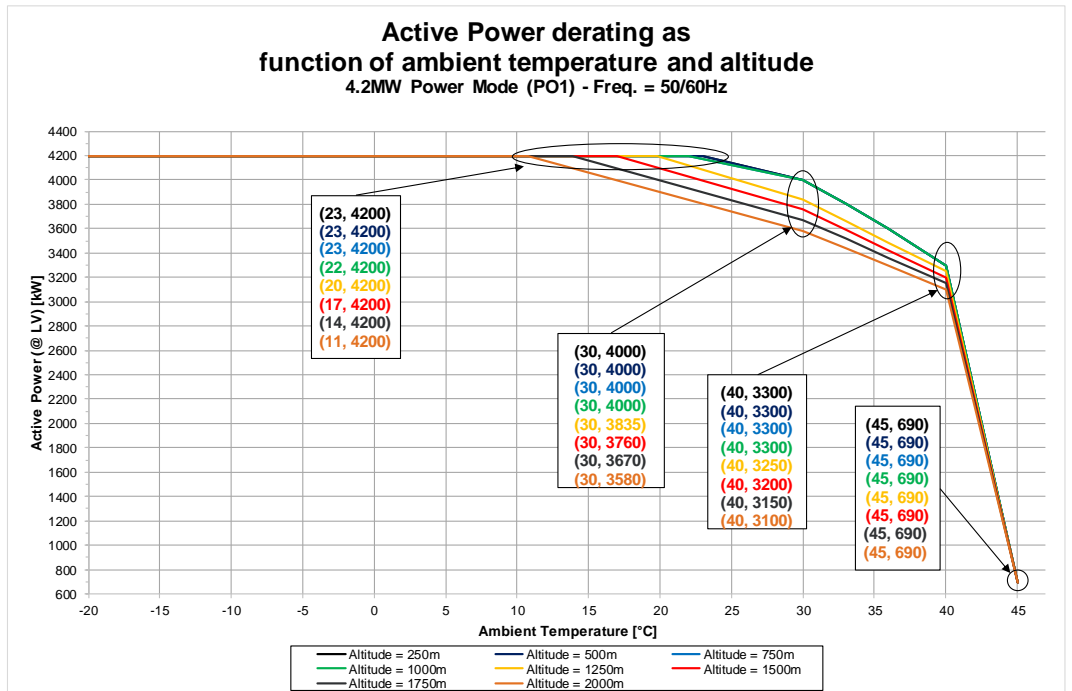

Figure 10-1: Temperature dependant derated operation – Standard Cooler Top.

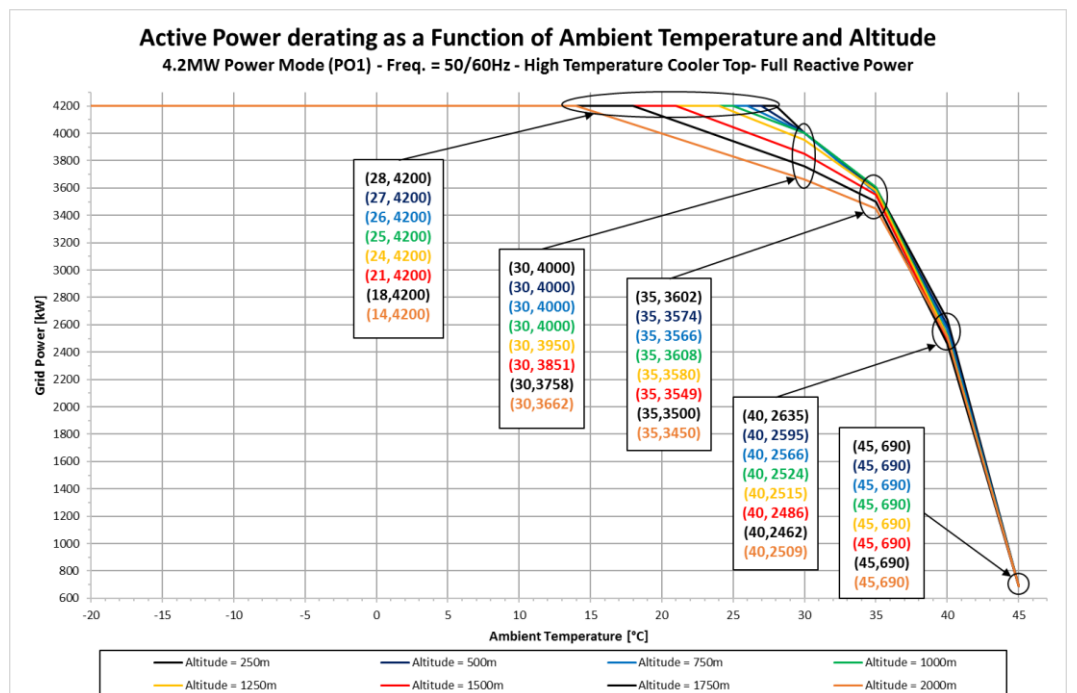

Figure 10-2: Temperature dependant derated operation – High Temperature Cooler Top.

## 10.4 Operational Envelope – Grid Connection

| Operational Envelope – Grid Connection                               |   |          |
|--|---|----------|
| <b>Nominal Phase Voltage</b>   | [U <sub>NP</sub> ]                        | 720 V    |
| <b>Nominal Frequency</b>   | [f <sub>N</sub> ]                         | 50/60 Hz |
| <b>Maximum Frequency Gradient</b>                                    | ±4 Hz/sec.                                |          |
| <b>Maximum Negative Sequence Voltage</b>                             | 3% (connection) 2% (operation)            |          |
| <b>Minimum Required Short Circuit Ratio at Turbine HV Connection</b> | 5.0 (contact Vestas for lower SCR levels) |          |
| <b>Maximum Short Circuit Current Contribution</b>                    | Contact Vestas for details                |          |

Table 10-3: Operational envelope – grid connection

The generator and the converter will be disconnected if\*:

| Protection Settings   |            |
|---|------------|
| <b>Voltage Above 110%** of Nominal for 1800 Seconds</b>     | 792 V      |
| <b>Voltage Above 116% of Nominal for 60 Seconds</b>         | 835 V      |
| <b>Voltage Above 125% of Nominal for 2 Seconds</b>          | 900 V      |
| <b>Voltage Above 136% of Nominal for 0.150 Seconds</b>      | 979 V      |
| <b>Voltage Below 90%** of Nominal for 180 Seconds (FRT)</b> | 648 V      |
| <b>Voltage Below 85% of Nominal for 12 Seconds (FRT)</b>    | 612 V      |
| <b>Voltage Below 80% of Nominal for 4.8 Seconds (FRT)</b>   | 576 V      |
| <b>Frequency is Above 106% of Nominal for 0.2 Seconds</b>   | 53/63.6 Hz |
| <b>Frequency is Below 94% of Nominal for 0.2 Seconds</b>    | 47/56.4 Hz |

Table 10-4: Generator and converter disconnecting values

**NOTE**

\* Over the turbine lifetime, grid drop-outs are to occur at an average of no more than 50 times a year.

\*\* The turbine may be configured for continuous operation @ +/- 13 % voltage. Reactive power capability is limited for these widened settings to an extent that is yet to be determined.





### 10.5 Operational Envelope – Reactive Power Capability in 4.0 MW Mode 0

The turbine has a reactive power capability in 4.0 MW Mode 0 on the low voltage side of the HV transformer as illustrated in Figure 10-3:

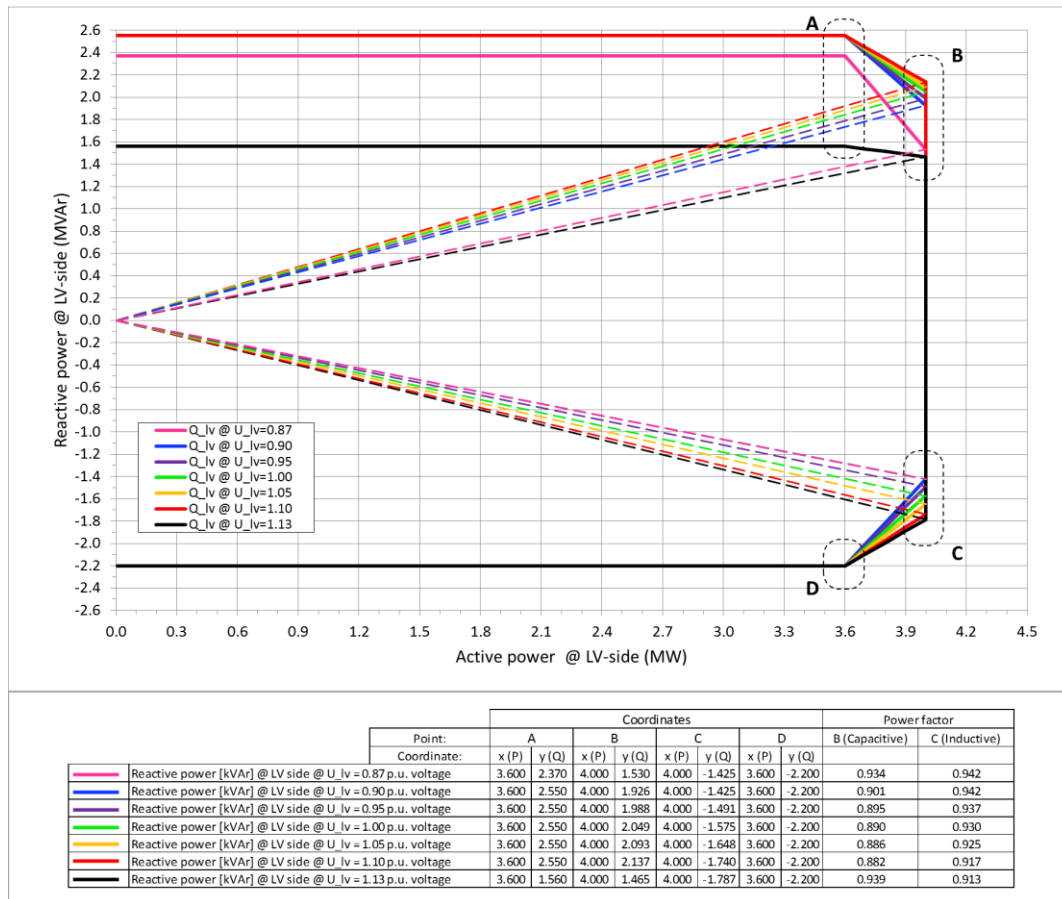

Figure 10-3: Reactive power capability for 4.0 MW Mode 0.

When operating at 4.0 MW nominal power at LV side of the HV transformer, the reactive power capability on the high voltage side of the HV transformer is approximately:

- $\cos\phi(\text{HV}) = 0.95/0.90$  capacitive/inductive @  $U(\text{HV}) = 0.90$  p.u. voltage
- $\cos\phi(\text{HV}) = 0.93/0.87$  capacitive/inductive @  $U(\text{HV}) = 1.10$  p.u. voltage

Reactive power is produced by the full-scale converter. Traditional capacitors are, therefore, not used in the turbine.

The turbine is able to maintain the reactive power capability at low wind with no active power production.



### 10.6 Operational Envelope – Reactive Power Capability in 4.0 MW Reactive Power Optimized Mode (QO1)

An optional, extended reactive power capability is available with 4.0 MW Reactive Power Optimized Mode (QO1) when ambient temperature is below +20°C for  $\leq 1000$  m.a.s.l. The reactive power capability is as seen in Figure 10-4:

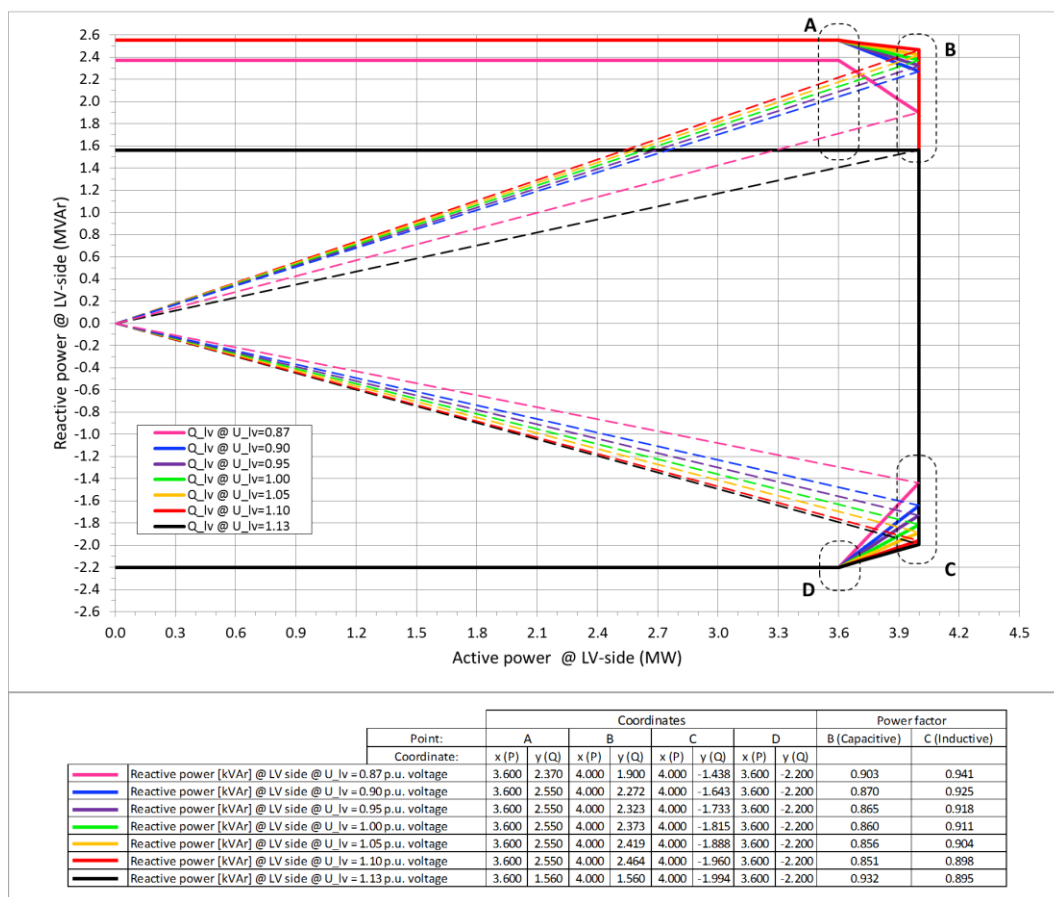

Figure 10-4: Reactive power capability for 4.0 MW Reactive Power Optimized Mode (QO1).

When operating at 4.0 MW in Reactive Power Optimized Mode (QO1) at LV side of the HV transformer, the reactive power capability on the high voltage side of the HV transformer is approximately:

- $\cos\phi(\text{HV}) = 0.92/0.88$  capacitive/inductive @  $U(\text{HV}) = 0.90$  p.u. voltage
- $\cos\phi(\text{HV}) = 0.90/0.85$  capacitive/inductive @  $U(\text{HV}) = 1.10$  p.u. voltage

The turbine is able to maintain the reactive power capability at low wind with no active power production.

**NOTE**

4.0 MW Reactive Power Optimized Mode (QO1) derates reactive power linearly above +20°C ambient temperature to converge with the reactive power capability of 4.0 MW Mode 0 in Figure 10-3 at +30°C.



### 10.7 Operational Envelope – Reactive Power Capability in 4.2 MW Power Optimized Mode (PO1)

The reactive power capability for the 4.2 MW Power Optimized Mode (PO1) is as illustrated in Figure 10-5:

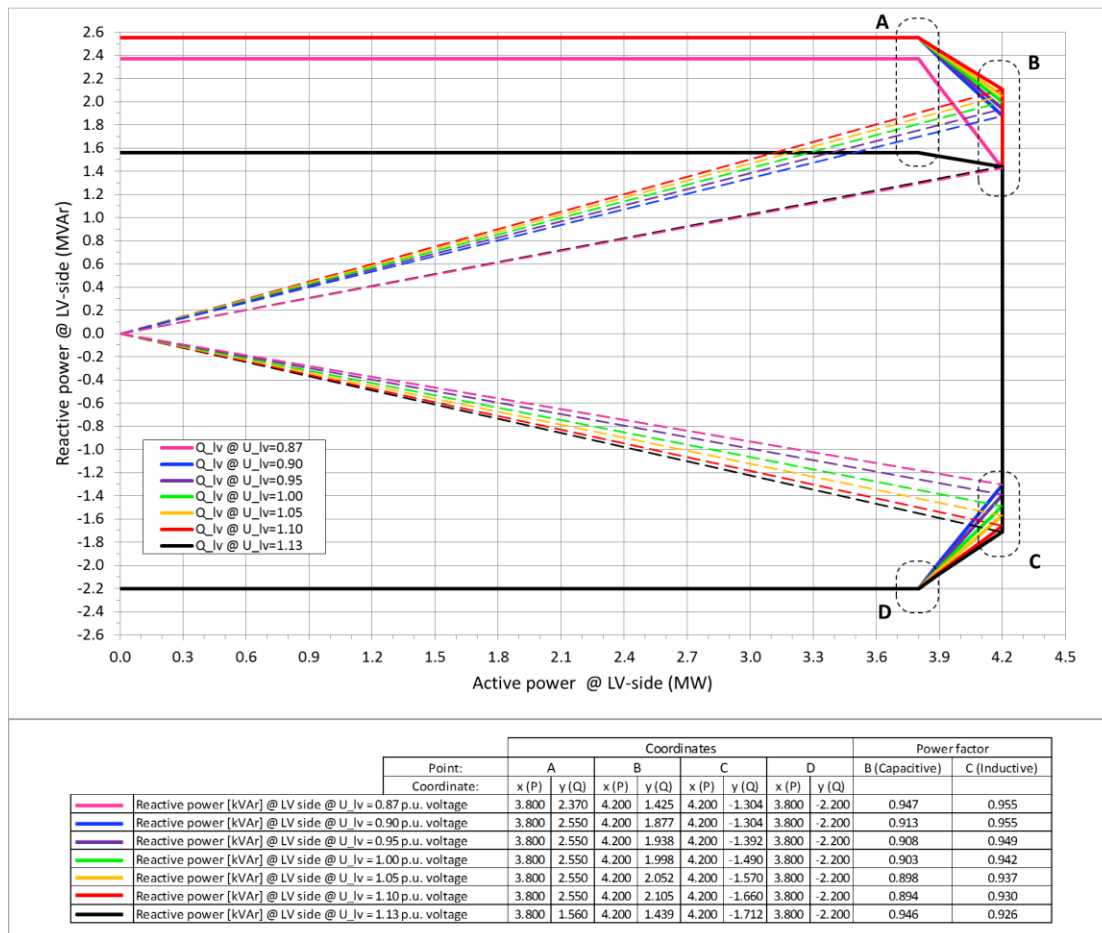

Figure 10-5: Reactive power capability for 4.2 MW Power Optimized Mode (PO1).

When operating at 4.2 MW in Power Optimized Mode (PO1) at LV side of the HV transformer, the reactive power capability on the high voltage side of the HV transformer is approximately:

- $\cos\phi(\text{HV}) = 0.95/0.91$  capacitive/inductive @  $U(\text{HV}) = 0.90$  p.u. voltage
- $\cos\phi(\text{HV}) = 0.94/0.88$  capacitive/inductive @  $U(\text{HV}) = 1.10$  p.u. voltage

The turbine is able to maintain the reactive power capability at low wind with no active power production.

**NOTE**

4.2 MW Power Optimized Mode (PO1) is mutually exclusive with 4.0 MW Reactive Power Optimized Mode (QO1) (since Q is traded for P).

### 10.8 Operational Envelope – Temperature dependent Reactive Power Capability

The reactive power capabilities shown in Figure 10-3, Figure 10-4 and Figure 10-5 are valid for ambient temperatures at which no active power derate is needed according to **Error! Reference source not found.** and **Error! Reference source not found.**

For ambient temperatures up to 40°C, where active power is derated as a consequence of ambient temperature, the shape of the PQ chart (E.g. Figure 10-3: A, B, C and D points) is maintained. The active power for the A, B, C and D points is however adjusted according to the overall WTG active power derate according to Figure 10-1 and Figure 10-2.

For ambient temperatures between 40°C and 45°C, reactive power is derated proportional to the active power derate.

Figure 10-6 shows an illustrative example of the reactive power derate.

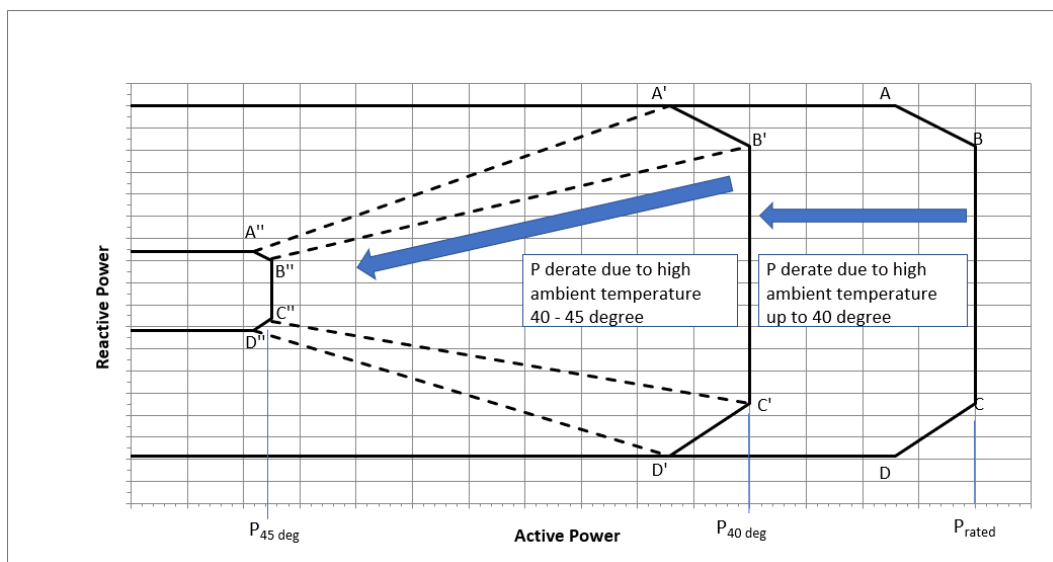

Figure 10-6: Reactive power capability temperature dependency. Illustrative example.

## 10.9 Performance – Fault Ride Through

The turbine is equipped with a full-scale converter to gain better control of the wind turbine during grid faults. The turbine control system continues to run during grid faults.

The turbine is designed to stay connected during grid disturbances within the voltage tolerance curve as illustrated below:

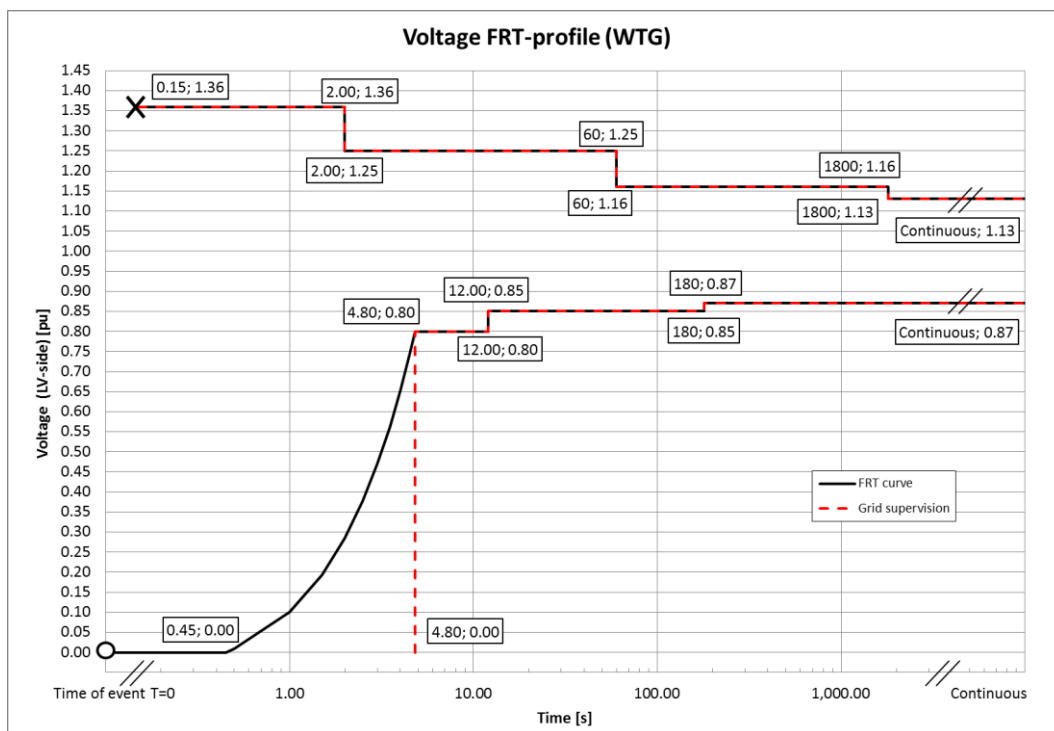

Figure 10-7: Voltage tolerance curve for symmetrical and asymmetrical faults, where U represents voltage as measured on the grid.

For grid disturbances outside the tolerance curve in Figure 10-7, the turbine will be disconnected from the grid.

| Power Recovery Time                      |                     |
|--|---------------------|
| Power Recovery to 90% of Pre-Fault Level | Maximum 0.1 seconds |

Table 10-5: Power recovery time

## 10.10 Performance – Reactive Current Contribution

The reactive current contribution depends on whether the fault applied to the turbine is symmetrical or asymmetrical. Symmetrical Reactive Current Contribution

During symmetrical voltage dips, the wind farm will inject reactive current to support the grid voltage. The reactive current injected is a function of the measured grid voltage.

The default value gives a reactive current part of 1 p.u. of the rated active current at the high voltage side of the HV transformer. Figure 10-8, indicates the reactive current contribution as a function of the voltage. The reactive current contribution is independent from the actual wind conditions and pre-fault power level. As seen in Figure 10-8, the default current injection slope is 2% reactive current increase per 1% voltage decrease. The slope can be parameterized between 0 and 10 to adapt to site specific requirements.

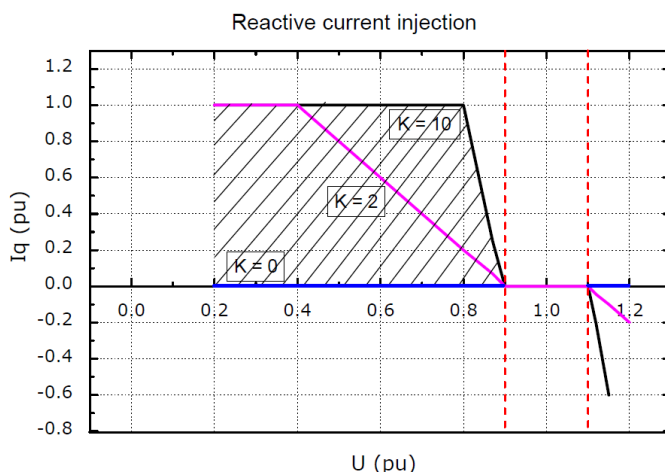

Figure 10-8: Reactive current injection

### 10.10.1 Asymmetrical Reactive Current Contribution

The injected current is based on the measured positive sequence voltage and the used K-factor. During asymmetrical voltage dips, the reactive current injection is limited to approximate 0.4 p.u. to limit the potential voltage increase on the healthy phases.

## 10.11 Performance – Multiple Voltage Dips

The turbine is designed to handle re-closure events and multiple voltage dips within a short period of time due to the fact that voltage dips are not evenly distributed during the year. For example, the turbine is designed to handle 10 voltage dips of duration of 200 ms, down to 20% voltage, within 30 minutes.

## 10.12 Performance – Active and Reactive Power Control

The turbine is designed for control of active and reactive power via the VestasOnline® SCADA system.

| Maximum Ramp Rates for External Control |  |
|---|--|
| <b>Active Power</b>                     | 0.1 p.u./sec for max. power level change of 0.3 p.u.<br>0.3 p.u./sec for max. power level change of 0.1 p.u. |
| <b>Reactive Power</b>                   | 20 p.u./sec  |

*Table 10-6: Active/reactive power ramp rates.*

To support grid stability the turbine is capable to stay connected to the grid at active power references down to 10 % of nominal power for the turbine. For active power references below 10 % the turbine may disconnect from the grid.

## 10.13 Performance – Voltage Control

The turbine is designed for integration with VestasOnline® voltage control by utilising the turbine reactive power capability.

## 10.14 Performance – Frequency Control

The turbine can be configured to perform frequency control by decreasing the output power as a linear function of the grid frequency (over frequency). Dead band and slope for the frequency control function are configurable.

## 10.15 Distortion – Immunity

The turbine is able to connect with a pre-connection (background) voltage distortion level at the grid interface of 8% and operate with a post-connection voltage distortion level of 8%.

## 10.16 Main Contributors to Own Consumption

The consumption of electrical power by the wind turbine is defined as the power used by the wind turbine when it is not providing energy to the grid. This is defined in the control system as Production Generator 0 (zero).

The components in Table 10-7 have the largest influence on the own consumption of the wind turbine (the average own consumption depends on the actual conditions, the climate, the wind turbine output, the cut-off hours, etc.).

The VMP8000 control system has a hibernate mode that reduces own consumption when possible. Similarly, cooling pumps may be turned off when the turbine idles.





| <b>Main contributors to Own Consumption</b>   |  |
|---|--|
| <b>Hydraulic Motor</b>  | 2 x 15 (V117) / 18.5 kW (V136 + V150) (master-slave) |
| <b>Yaw Motors</b>   | Maximum 21 kW in total                               |
| <b>Water Heating</b>  | 10 kW  |
| <b>Water Pumps</b>  | 2.2 + 5.5 kW   |
| <b>Oil Heating</b>  | 7.9 kW   |
| <b>Oil Pump for Gearbox Lubrication</b>   | 12.5 kW  |
| <b>Controller Including Heating Elements for the Hydraulics and all Controllers</b> | Approximately 3 kW                                   |
| <b>HV Transformer No-load Loss</b>  | See section 4.3 HV Transformer, p. 14                |

*Table 10-7: Main contributors to own consumption data.*





## 11 Drawings

### 11.1 Structural Design – Illustration of Outer Dimensions

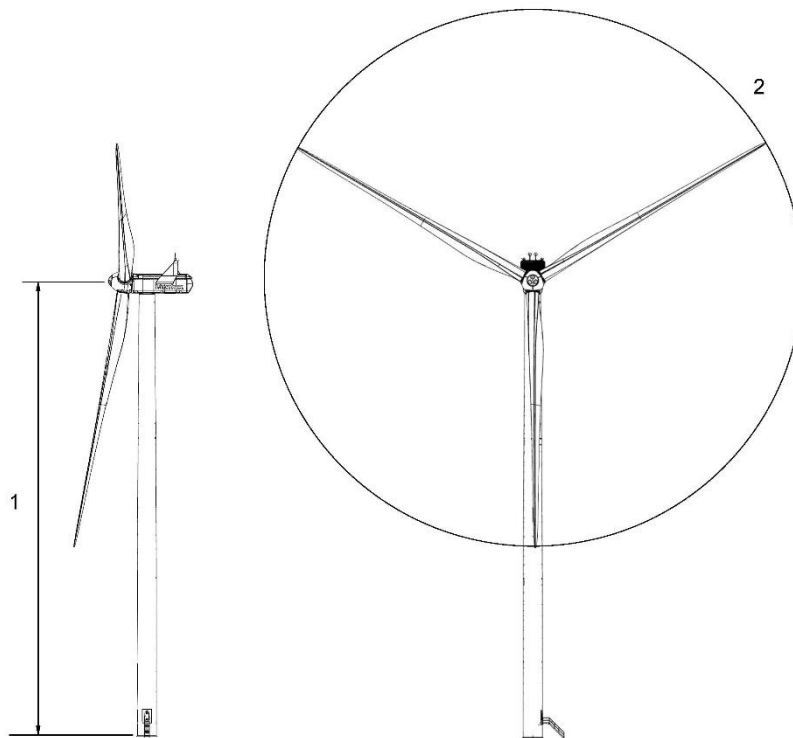

Figure 11-1: Illustration of outer dimensions – structure

- 1 Hub heights: See Performance Specification
- 2 Rotor diameter: 117-150 m

### 11.2 Structural Design – Side View Drawing

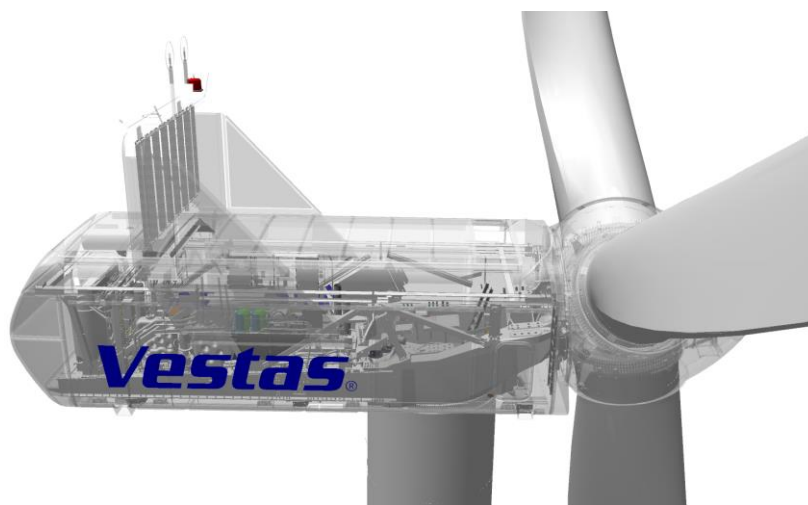

Figure 11-2: Side-view drawing



## 12 General Reservations, Notes and Disclaimers

- © 2017 Vestas Wind Systems A/S. This document is created by Vestas Wind Systems A/S and/or its affiliates and contains copyrighted material, trademarks, and other proprietary information. All rights reserved. No part of the document may be reproduced or copied in any form or by any means – such as graphic, electronic, or mechanical, including photocopying, taping, or information storage and retrieval systems – without the prior written permission of Vestas Wind Systems A/S. The use of this document is prohibited unless specifically permitted by Vestas Wind Systems A/S. Trademarks, copyright or other notices may not be altered or removed from the document.
- The general descriptions in this document apply to the current version of the 4MW Platform wind turbines. Updated versions of the 4MW Platform wind turbines, which may be manufactured in the future, may differ from this general description. In the event that Vestas supplies an updated version of a specific 4MW Platform wind turbine, Vestas will provide an updated general description applicable to the updated version.
- Vestas recommends that the grid be as close to nominal as possible with limited variation in frequency and voltage.
- A certain time allowance for turbine warm-up must be expected following grid dropout and/or periods of very low ambient temperature.
- All listed start/stop parameters (e. g. wind speeds and temperatures) are equipped with hysteresis control. This can, in certain borderline situations, result in turbine stops even though the ambient conditions are within the listed operation parameters.
- The earthing system must comply with the minimum requirements from Vestas, and be in accordance with local and national requirements and codes of standards.
- This document, General Description, is not an offer for sale, and does not contain any guarantee, warranty and/or verification of the power curve and noise (including, without limitation, the power curve and noise verification method). Any guarantee, warranty and/or verification of the power curve and noise (including, without limitation, the power curve and noise verification method) must be agreed to separately in writing.

Restricted  
Document no.: 0067-7066 V08  
2020-09-29

# Performance Specification

## V136-4.0/4.2 MW 50/60 Hz (Low HH)



## Table of contents

|           |  |           |
|-----------|--|-----------|
| <b>1</b>  | <b>GENERAL DESCRIPTION .....</b>   | <b>5</b>  |
| <b>2</b>  | <b>TYPE APPROVALS AND AVAILABLE HUB HEIGHTS .....</b>  | <b>5</b>  |
| <b>3</b>  | <b>OPERATIONAL ENVELOPE AND PERFORMANCE GUIDELINES .....</b>                                 | <b>5</b>  |
| 3.1       | CLIMATE AND SITE CONDITIONS .....  | 5         |
| 3.1.1     | <i>Complex Terrain</i> .....   | 6         |
| 3.1.2     | <i>Altitude</i> .....  | 6         |
| 3.1.3     | <i>Wind Power Plant Layout</i> .....   | 6         |
| 3.2       | OPERATIONAL ENVELOPE – WIND .....  | 6         |
| 3.3       | OPERATIONAL ENVELOPE – WIND (HWO) .....  | 7         |
| 3.4       | OPERATIONAL ENVELOPE – CONDITIONS FOR POWER CURVE AND Ct VALUES (AT HUB HEIGHT) .....        | 7         |
| 3.5       | SOUND MODES .....  | 8         |
| 3.6       | LOAD MODES .....   | 9         |
| <b>4</b>  | <b>DRAWINGS .....</b>  | <b>10</b> |
| 4.1       | STRUCTURAL DESIGN – ILLUSTRATION OF OUTER DIMENSIONS .....                                   | 10        |
| <b>5</b>  | <b>GENERAL RESERVATIONS, NOTES AND DISCLAIMERS .....</b>                                     | <b>11</b> |
| <b>6</b>  | <b>POWER CURVES, CT VALUES AND SOUND CURVES, MODE 0/0-0S .....</b>                           | <b>12</b> |
| 6.1       | POWER CURVES, MODE 0/0-0S .....  | 12        |
| 6.2       | CT VALUES, MODE 0/0-0S .....   | 13        |
| 6.3       | SOUND CURVES, MODE 0/0-0S .....  | 14        |
| <b>7</b>  | <b>POWER CURVES, CT VALUES AND SOUND CURVES, MODE 0/0-0S (HWO) .....</b>                     | <b>15</b> |
| 7.1       | POWER CURVES, MODE 0/0-0S (HWO) .....  | 15        |
| 7.2       | CT VALUES, MODE 0/0-0S (HWO) .....   | 17        |
| 7.3       | SOUND CURVES, MODE 0/0-0S (HWO) .....  | 18        |
| <b>8</b>  | <b>POWER CURVES, CT VALUES AND SOUND CURVES, POWER OPTIMIZED MODE PO1/PO1-0S .....</b>       | <b>19</b> |
| 8.1       | POWER CURVES, POWER OPTIMIZED MODE PO1/PO1-0S .....  | 19        |
| 8.2       | CT VALUES, POWER OPTIMIZED MODE PO1/PO1-0S .....   | 20        |
| 8.3       | SOUND CURVES, POWER OPTIMIZED MODE PO1/PO1-0S .....  | 21        |
| <b>9</b>  | <b>POWER CURVES, CT VALUES AND SOUND CURVES, POWER OPTIMIZED MODE PO1/PO1-0S (HWO) .....</b> | <b>22</b> |
| 9.1       | POWER CURVES, POWER OPTIMIZED MODE PO1/PO1-0S (HWO) .....                                    | 22        |
| 9.2       | CT VALUES, POWER OPTIMIZED MODE PO1/PO1-0S (HWO) .....                                       | 24        |
| 9.3       | SOUND CURVES, POWER OPTIMIZED MODE PO1/PO1-0S (HWO) .....                                    | 25        |
| <b>10</b> | <b>POWER CURVES, CT VALUES AND SOUND CURVES, SOUND OPTIMIZED MODE SO1 .....</b>              | <b>26</b> |
| 10.1      | POWER CURVES, SOUND OPTIMIZED MODE SO1 .....   | 26        |
| 10.2      | CT VALUES, SOUND OPTIMIZED MODE SO1 .....  | 27        |
| 10.3      | SOUND CURVES, SOUND OPTIMIZED MODE SO1 .....   | 28        |
| <b>11</b> | <b>POWER CURVES, CT VALUES AND SOUND CURVES, SOUND OPTIMIZED MODE SO1 (HWO) .....</b>        | <b>29</b> |
| 11.1      | POWER CURVES, SOUND OPTIMIZED MODE SO1 (HWO) .....   | 29        |
| 11.2      | CT VALUES, SOUND OPTIMIZED MODE SO1 (HWO) .....  | 31        |
| 11.3      | SOUND CURVES, SOUND OPTIMIZED MODE SO1 (HWO) .....   | 32        |
| <b>12</b> | <b>POWER CURVES, CT VALUES AND SOUND CURVES, SOUND OPTIMIZED MODE SO2 .....</b>              | <b>33</b> |
| 12.1      | POWER CURVES, SOUND OPTIMIZED MODE SO2 .....   | 33        |
| 12.2      | CT VALUES, SOUND OPTIMIZED MODE SO2 .....  | 34        |
| 12.3      | SOUND CURVES, SOUND OPTIMIZED MODE SO2 .....   | 35        |

|           |  |           |
|-----------|--|-----------|
| <b>13</b> | <b>POWER CURVES, CT VALUES AND SOUND CURVES, SOUND OPTIMIZED MODE SO2 (HWO)</b>  | <b>36</b> |
| 13.1      | POWER CURVES, SOUND OPTIMIZED MODE SO2 (HWO)                                     | 36        |
| 13.2      | CT VALUES, SOUND OPTIMIZED MODE SO2 (HWO)  | 38        |
| 13.3      | SOUND CURVES, SOUND OPTIMIZED MODE SO2 (HWO)                                     | 39        |
| <b>14</b> | <b>POWER CURVES, CT VALUES AND SOUND CURVES, SOUND OPTIMIZED MODE SO11</b>       | <b>40</b> |
| 14.1      | POWER CURVES, SOUND OPTIMIZED MODE SO11  | 40        |
| 14.2      | CT VALUES, SOUND OPTIMIZED MODE SO11   | 41        |
| 14.3      | SOUND CURVES, SOUND OPTIMIZED MODE SO11  | 42        |
| <b>15</b> | <b>POWER CURVES, CT VALUES AND SOUND CURVES, SOUND OPTIMIZED MODE SO11 (HWO)</b> | <b>43</b> |
| 15.1      | POWER CURVES, SOUND OPTIMIZED MODE SO11 (HWO)                                    | 43        |
| 15.2      | CT VALUES, SOUND OPTIMIZED MODE SO11 (HWO)                                       | 45        |
| 15.3      | SOUND CURVES, SOUND OPTIMIZED MODE SO11 (HWO)                                    | 46        |
| <b>16</b> | <b>POWER CURVES, CT VALUES AND SOUND CURVES, SOUND OPTIMIZED MODE SO12</b>       | <b>47</b> |
| 16.1      | POWER CURVES, SOUND OPTIMIZED MODE SO12  | 47        |
| 16.2      | CT VALUES, SOUND OPTIMIZED MODE SO12   | 48        |
| 16.3      | SOUND CURVES, SOUND OPTIMIZED MODE SO12  | 49        |
| <b>17</b> | <b>POWER CURVES, CT VALUES AND SOUND CURVES, SOUND OPTIMIZED MODE SO12 (HWO)</b> | <b>50</b> |
| 17.1      | POWER CURVES, SOUND OPTIMIZED MODE SO12 (HWO)                                    | 50        |
| 17.2      | CT VALUES, SOUND OPTIMIZED MODE SO12 (HWO)                                       | 52        |
| 17.3      | SOUND CURVES, SOUND OPTIMIZED MODE SO12 (HWO)                                    | 53        |
| <b>18</b> | <b>POWER CURVES, CT VALUES AND SOUND CURVES, SOUND OPTIMIZED MODE SO13</b>       | <b>54</b> |
| 18.1      | POWER CURVES, SOUND OPTIMIZED MODE SO13  | 54        |
| 18.2      | CT VALUES, SOUND OPTIMIZED MODE SO13   | 55        |
| 18.3      | SOUND CURVES, SOUND OPTIMIZED MODE SO13  | 56        |
| <b>19</b> | <b>POWER CURVES, CT VALUES AND SOUND CURVES, SOUND OPTIMIZED MODE SO13 (HWO)</b> | <b>57</b> |
| 19.1      | POWER CURVES, SOUND OPTIMIZED MODE SO13 (HWO)                                    | 57        |
| 19.2      | CT VALUES, SOUND OPTIMIZED MODE SO13 (HWO)                                       | 59        |
| 19.3      | SOUND CURVES, SOUND OPTIMIZED MODE SO13 (HWO)                                    | 60        |
| <b>20</b> | <b>POWER CURVES, CT VALUES AND SOUND CURVES, LOAD OPTIMIZED MODE LO1</b>         | <b>61</b> |
| 20.1      | POWER CURVES, LOAD OPTIMIZED MODE LO1  | 61        |
| 20.2      | CT VALUES, LOAD OPTIMIZED MODE LO1   | 62        |
| 20.3      | SOUND CURVES, LOAD OPTIMIZED MODE LO1  | 63        |
| <b>21</b> | <b>POWER CURVES, CT VALUES AND SOUND CURVES, LOAD OPTIMIZED MODE LO1 (HWO)</b>   | <b>64</b> |
| 21.1      | POWER CURVES, LOAD OPTIMIZED MODE LO1 (HWO)                                      | 64        |
| 21.2      | CT VALUES, LOAD OPTIMIZED MODE LO1 (HWO)   | 66        |
| 21.3      | SOUND CURVES, LOAD OPTIMIZED MODE LO1 (HWO)                                      | 67        |
| <b>22</b> | <b>POWER CURVES, CT VALUES AND SOUND CURVES, LOAD OPTIMIZED MODE LO2</b>         | <b>68</b> |
| 22.1      | POWER CURVES, LOAD OPTIMIZED MODE LO2  | 68        |
| 22.2      | CT VALUES, LOAD OPTIMIZED MODE LO2   | 69        |
| 22.3      | SOUND CURVES, LOAD OPTIMIZED MODE LO2  | 70        |
| <b>23</b> | <b>POWER CURVES, CT VALUES AND SOUND CURVES, LOAD OPTIMIZED MODE LO2 (HWO)</b>   | <b>71</b> |
| 23.1      | POWER CURVES, LOAD OPTIMIZED MODE LO2 (HWO)                                      | 71        |
| 23.2      | CT VALUES, LOAD OPTIMIZED MODE LO2 (HWO)   | 73        |
| 23.3      | SOUND CURVES, LOAD OPTIMIZED MODE LO2 (HWO)                                      | 74        |

**Recipient acknowledges that (i) this Performance Specification is provided for recipient's information only, and, does not create or constitute a warranty, guarantee, promise, commitment, or other representation (Commitment) by Vestas Wind Systems or any of its affiliated or subsidiary companies (Vestas), all of which are disclaimed by Vestas and (ii) any and all Commitments by Vestas to recipient as to this Performance Specification (or any of the contents herein) are to be contained exclusively in signed written contracts between recipient and Vestas, and not within this document.**

**See general reservations, notes and disclaimers (including, Section 5, p. 11) to this Performance Specification.**

## 1 General Description

The Vestas V136-4.0/4.2 MW wind turbine is a pitch regulated upwind turbine with active yaw and a three-blade rotor. The Vestas V136-4.0/4.2 MW turbine has a rotor diameter of 136 m and a rated power of 4.0 MW.

Vestas offers an optional Power Optimized (PO) mode at 4.2 MW for the V136-4.0 MW variant.

## 2 Type Approvals and Available Hub Heights

The standard turbine is type certified according to the certification standards and available hub heights listed below:

| Certification      | Wind Class | Hub Height          |
|--------------------|------------|---------------------|
| <b>Tower type</b>  |            | <b>Standard</b>     |
| <b>IEC61400-22</b> | IEC IIB    | 82 m <sup>(1)</sup> |

Table 2-1: Type approval data and available hub heights

<sup>(1)</sup>: Special transport optimized tower for US/Canada.

The hub height can be increased by up to 3 m by use of raised foundation. Use of raised foundation is subject to site-specific evaluation and is not available for all soil conditions.

## 3 Operational Envelope and Performance Guidelines

Actual climate and site conditions have many variables and should be considered in evaluating actual turbine performance. The design and operating parameters set forth in this section do not constitute warranties, guarantees, or representations as to turbine performance at actual sites.

### 3.1 Climate and Site Conditions

The standard turbine is designed for the wind climate conditions listed below. Values refer to hub height.

| Wind Climate   | IEC IIB      | IEC S        |
|--|--------------|--------------|
| <b>Hub Height</b>  | <b>82 m</b>  | <b>82 m</b>  |
| <b>Power Rating</b>  | <b>4.0MW</b> | <b>4.2MW</b> |
| <b>Extr Wind Speed (10 min average), <math>V_{50}</math></b> | 42.5 m/s     | 42.5 m/s     |
| <b>Survival Wind Speed (3 s gust), <math>V_{e50}</math></b>  | 59.5 m/s     | 59.5 m/s     |
| <b>Turbulence Intensity, <math>I_{v50}</math></b>            | 11%          | 11%          |

Table 3-1: Extreme design parameters – IEC



| Wind Climate   | IEC IIB | IEC S   |
|--|---------|---------|
| Hub Height   | 82 m    | 82 m    |
| Power Rating   | 4.0MW   | 4.2MW   |
| Wind Speed (10 min average), $V_{ave}$   | 8.5 m/s | 8.0 m/s |
| Weibull Scale Factor, $C$  | 9.6 m/s | 8.9 m/s |
| Weibull Shape Factor, $k$  | 2.0     | 2.0     |
| $I_{ref}$ acc. to IEC 61400-1  | 0.14    | 0.14    |
| Turbulence Intensity acc. to IEC 61400-1, Including Wind Farm Turbulence (@15 m/s) $I_{90}$ (90% quantile) | 15.7%   | 15.7%   |
| Wind Shear, $\alpha$   | 0.20    | 0.20    |
| Inflow Angle (vertical)  | 8°      | 8°      |

Table 3-2: Average design parameters – IEC

### 3.1.1 Complex Terrain

Classification of complex terrain according to IEC 61400-1:2005 Chapter 11.2. For sites classified as complex, appropriate measures are to be included in site assessment. Positioning of each turbine must be verified via Vestas Site Check.

### 3.1.2 Altitude

The turbine is designed for use at altitudes up to 1000 m above sea level as standard and optional up to 2000 m above sea level.

### 3.1.3 Wind Power Plant Layout

Turbine spacing is to be evaluated site-specifically. Spacing below two rotor diameters (2D) may require sector-wise curtailment.

**NOTE** As evaluation of climate and site conditions is complex, consult Vestas for every project. If conditions exceed the above parameters, Vestas must be consulted.

## 3.2 Operational Envelope – Wind

Values refer to hub height and are determined by the sensors and control system of the turbine.

| Wind Climate                                 | IEC IIB  |
|--|----------|
| Hub Height                                   | 82 m     |
| Cut-In, $V_{in}$                             | 3 m/s    |
| Cut-Out (10 min exponential avg.), $V_{out}$ | 27.0 m/s |
| Re-Cut In (10 min exponential avg.)          | 25.0 m/s |

Table 3-3: Operational envelope – wind – IEC



### 3.3 Operational Envelope – Wind (HWO)

Optionally, the turbine can be offered with the High Wind Operation (HWO) control feature. The HWO control feature allows the turbine to operate up to the extended cut-out wind speeds listed in Table 3-4, p. 7, with a controlled derating of power and speed. The power curves associated with optional HWO control are found in Sections 7, 9, 11 and 13. Values refer to hub height and are determined by the sensors and control system of the turbine.

| Wind climate   | IEC IIB     |
|--|-------------|
| <b>Hub height</b>  | <b>82 m</b> |
| <b>Cut-In, <math>V_{in}</math></b>                             | 3 m/s       |
| <b>Cut-Out (10 min exponential avg.), <math>V_{out}</math></b> | 32.0 m/s    |
| <b>Re-Cut In (10 min exponential avg.)</b>                     | 30.0 m/s    |

*Table 3-4: Operational envelope – wind – IEC (High Wind Operation)*

### 3.4 Operational Envelope – Conditions for Power Curve and $C_t$ Values (at Hub Height)

Consult Section 6 and following sections for power curves and  $C_t$  values.

| Conditions for Power Curve and $C_t$ Values (at Hub Height) |  |
|---|--|
| <b>Wind Shear, <math>\alpha</math></b>                      | 0.00-0.30 (10 minute average)                  |
| <b>Turbulence Intensity, <math>I</math></b>                 | 6-12% (10 minute average)                      |
| <b>Blades</b>   | Clean  |
| <b>Rain</b>   | No   |
| <b>Ice/Snow on Blades</b>                                   | No   |
| <b>Leading Edge</b>   | No damage                                      |
| <b>Terrain</b>  | IEC 61400-12-1                                 |
| <b>Inflow Angle (Vertical)</b>                              | $0 \pm 2^\circ$                                |
| <b>Grid Voltage</b>   | Nominal Voltage $\pm 2.5\%$                    |
| <b>Grid Frequency</b>                                       | Nominal Frequency $\pm 0.5$ Hz                 |
| <b>Grid Active Power (LV-side of turbine transformer)</b>   | As per tabulated values from Section 6 onwards |
| <b>Grid Reactive Power (LV-side of turbine transformer)</b> | Power Factor 1.0                               |

*Table 3-5: Conditions for power curve and  $C_t$  values*

### 3.5 Sound Modes

The sound modes listed below are available for the turbine.

| Sound modes     |                     |                         |                       |
|-----------------|---------------------|-------------------------|-----------------------|
| Mode No.        | Maximum Sound Level | Serrated trailing edges | Available hub heights |
| 0/PO1           | 103.9 dBA           | Yes (standard)          | 82 m                  |
| 0-0S/<br>PO1-0S | 106.9 dBA           | No (option)             | 82 m                  |

Table 3-6: Available sound performance

**NOTE** The turbine is as standard equipped with serrated trailing edges on the blades. Optionally, Mode 0-0S/PO1-0S can be offered without serrated trailing edges mounted on the blades.

In addition, Sound Optimized (SO) modes as listed below are available as options for the turbine.

| Sound Optimized (SO) modes |                     |                         |                       |
|----------------------------|---------------------|-------------------------|-----------------------|
| Mode No.                   | Maximum Sound Level | Serrated trailing edges | Available hub heights |
| SO1                        | 102.0 dBA           | Yes                     | 82 m                  |
| SO2                        | 99.5 dBA            | Yes                     | 82 m                  |
| SO11                       | 99.2 dBA            | Yes                     | 82 m <sup>(1)</sup>   |
| SO12                       | 99.9 dBA            | Yes                     | 82 m <sup>(1)</sup>   |
| SO13                       | 97.0 dBA            | Yes                     | 82 m <sup>(1)</sup>   |

Table 3-7: Available Sound Optimized modes

<sup>(1)</sup>: SO11, SO12, SO13 is not applicable for DIBt towers

**NOTE** Sound Optimized (SO) modes are only available with serrated trailing edges on the blades. For further details on sound performance and in case of specific requests for sound modes per tower, please contact Vestas Wind Systems A/S.

### 3.6 Load Modes

The Load Optimized (LO) modes listed below are available for the turbine.

| Load Optimized (LO) modes |        |                     |                         |                       |
|---------------------------|--------|---------------------|-------------------------|-----------------------|
| Mode No.                  | Power  | Maximum Sound Level | Serrated trailing edges | Available hub heights |
| LO1                       | 3.8 MW | 103.9 dBA           | Yes                     | 82 m                  |
| LO2                       | 3.6 MW | 103.9 dBA           | Yes                     | 82 m                  |

*Table 3-8: Available Load Optimized modes*

**NOTE** Load Optimized (LO) modes are only available with serrated trailing edges mounted on the blades.

## 4 Drawings

### 4.1 Structural Design – Illustration of Outer Dimensions

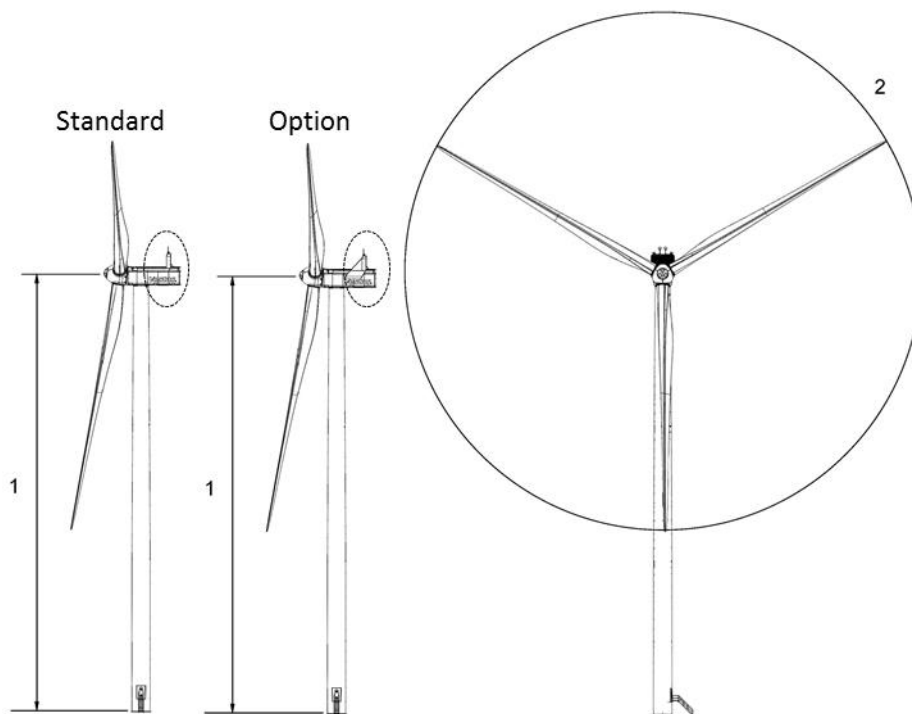

Figure 4-1: Illustration of outer dimensions – structure

**1** Hub height:  
82 m

**2** Diameter:  
136 m

---

**NOTE** The turbine to the right is shown with side panels on the cooler top (Option).

---

## 5 General Reservations, Notes and Disclaimers

- © 2017 Vestas Wind Systems A/S. This document is created by Vestas Wind Systems A/S and/or its affiliates and contains copyrighted material, trademarks, and other proprietary information. All rights reserved. No part of the document may be reproduced or copied in any form or by any means – such as graphic, electronic, or mechanical, including photocopying, taping, or information storage and retrieval systems – without the prior written permission of Vestas Wind Systems A/S. The use of this document is prohibited unless specifically permitted by Vestas Wind Systems A/S. Trademarks, copyright or other notices may not be altered or removed from the document.
- The performance specifications described in this document apply to the current version of the V136-4.0/4.2 MW wind turbine. Updated versions of the V136-4.0/4.2 MW wind turbine, which may be manufactured in the future, may differ from these performance specifications. In the event that Vestas supplies an updated version of the V136-4.0/4.2 MW wind, Vestas will provide an updated performance specification applicable to the updated version.
- All listed start/stop parameters (e.g. wind speeds) are equipped with hysteresis control. This can, in certain borderline situations, result in turbine stops even though the ambient conditions are within the listed operation parameters.
- This document, Performance Specification, is not an offer for sale, and does not contain any guarantee, warranty and/or verification of the power curve and sound (including, without limitation, the power curve and sound verification method). Any guarantee, warranty and/or verification of the power curve and sound (including, without limitation, the power curve and sound verification method) must be agreed to separately in writing.

## 6 Power Curves, Ct Values and Sound Curves, Mode 0/0-0S

**NOTE** The power curves and Ct values presented in Section 6 are only valid for low hub heights, i.e. hub heights ≤ 104 m.

### 6.1 Power Curves, Mode 0/0-0S

| Air density [kg/m <sup>3</sup> ] |       |      |       |      |       |      |       |      |       |      |       |      |      |       |
|----------------------------------|-------|------|-------|------|-------|------|-------|------|-------|------|-------|------|------|-------|
| Wind speed [m/s]                 | 1.225 | 0.95 | 0.975 | 1.0  | 1.025 | 1.05 | 1.075 | 1.1  | 1.125 | 1.15 | 1.175 | 1.2  | 1.25 | 1.275 |
| 3.0                              | 55    | 31   | 33    | 35   | 38    | 40   | 42    | 44   | 46    | 48   | 51    | 53   | 57   | 59    |
| 3.5                              | 130   | 89   | 93    | 97   | 100   | 104  | 108   | 111  | 115   | 119  | 122   | 126  | 133  | 137   |
| 4.0                              | 220   | 159  | 165   | 170  | 176   | 182  | 187   | 193  | 198   | 204  | 209   | 215  | 226  | 231   |
| 4.5                              | 331   | 245  | 253   | 260  | 268   | 276  | 284   | 292  | 299   | 307  | 315   | 323  | 338  | 346   |
| 5.0                              | 471   | 353  | 364   | 374  | 385   | 396  | 407   | 417  | 428   | 439  | 449   | 460  | 481  | 492   |
| 5.5                              | 639   | 483  | 497   | 511  | 526   | 540  | 554   | 568  | 582   | 596  | 610   | 624  | 653  | 667   |
| 6.0                              | 841   | 640  | 659   | 677  | 695   | 714  | 732   | 750  | 768   | 787  | 805   | 823  | 860  | 878   |
| 6.5                              | 1080  | 826  | 849   | 872  | 895   | 919  | 942   | 965  | 988   | 1011 | 1034  | 1057 | 1104 | 1127  |
| 7.0                              | 1361  | 1044 | 1073  | 1102 | 1131  | 1160 | 1189  | 1218 | 1247  | 1276 | 1304  | 1333 | 1390 | 1419  |
| 7.5                              | 1681  | 1293 | 1329  | 1364 | 1399  | 1435 | 1470  | 1505 | 1541  | 1576 | 1611  | 1646 | 1715 | 1750  |
| 8.0                              | 2042  | 1578 | 1620  | 1663 | 1706  | 1748 | 1790  | 1833 | 1875  | 1917 | 1959  | 2000 | 2083 | 2124  |
| 8.5                              | 2441  | 1897 | 1947  | 1998 | 2048  | 2099 | 2148  | 2198 | 2247  | 2296 | 2345  | 2393 | 2488 | 2535  |
| 9.0                              | 2845  | 2242 | 2300  | 2358 | 2415  | 2473 | 2527  | 2582 | 2636  | 2691 | 2742  | 2794 | 2894 | 2943  |
| 9.5                              | 3214  | 2591 | 2652  | 2713 | 2774  | 2836 | 2892  | 2948 | 3004  | 3060 | 3111  | 3163 | 3263 | 3311  |
| 10.0                             | 3547  | 2923 | 2985  | 3048 | 3110  | 3172 | 3228  | 3284 | 3340  | 3396 | 3447  | 3497 | 3592 | 3637  |
| 10.5                             | 3809  | 3228 | 3290  | 3354 | 3416  | 3480 | 3532  | 3585 | 3638  | 3691 | 3731  | 3770 | 3838 | 3867  |
| 11.0                             | 3949  | 3504 | 3561  | 3618 | 3676  | 3733 | 3772  | 3810 | 3849  | 3888 | 3908  | 3929 | 3960 | 3972  |
| 11.5                             | 3992  | 3739 | 3781  | 3824 | 3866  | 3908 | 3925  | 3942 | 3959  | 3976 | 3981  | 3986 | 3994 | 3996  |
| 12.0                             | 3999  | 3902 | 3921  | 3940 | 3960  | 3979 | 3983  | 3988 | 3992  | 3996 | 3997  | 3998 | 3999 | 4000  |
| 12.5                             | 4000  | 3970 | 3977  | 3983 | 3990  | 3996 | 3997  | 3998 | 3999  | 4000 | 4000  | 4000 | 4000 | 4000  |
| 13.0                             | 4000  | 3992 | 3994  | 3996 | 3997  | 3999 | 4000  | 4000 | 4000  | 4000 | 4000  | 4000 | 4000 | 4000  |
| 13.5                             | 4000  | 3994 | 3995  | 3997 | 3998  | 3999 | 4000  | 4000 | 4000  | 4000 | 4000  | 4000 | 4000 | 4000  |
| 14.0                             | 4000  | 3998 | 3998  | 3999 | 3999  | 4000 | 4000  | 4000 | 4000  | 4000 | 4000  | 4000 | 4000 | 4000  |
| 14.5                             | 4000  | 3999 | 4000  | 4000 | 4000  | 4000 | 4000  | 4000 | 4000  | 4000 | 4000  | 4000 | 4000 | 4000  |
| 15.0                             | 4000  | 3999 | 3999  | 4000 | 4000  | 4000 | 4000  | 4000 | 4000  | 4000 | 4000  | 4000 | 4000 | 4000  |
| 15.5                             | 4000  | 4000 | 4000  | 4000 | 4000  | 4000 | 4000  | 4000 | 4000  | 4000 | 4000  | 4000 | 4000 | 4000  |
| 16.0                             | 4000  | 4000 | 4000  | 4000 | 4000  | 4000 | 4000  | 4000 | 4000  | 4000 | 4000  | 4000 | 4000 | 4000  |
| 16.5                             | 4000  | 4000 | 4000  | 4000 | 4000  | 4000 | 4000  | 4000 | 4000  | 4000 | 4000  | 4000 | 4000 | 4000  |
| 17.0                             | 4000  | 4000 | 4000  | 4000 | 4000  | 4000 | 4000  | 4000 | 4000  | 4000 | 4000  | 4000 | 4000 | 4000  |
| 17.5                             | 4000  | 4000 | 4000  | 4000 | 4000  | 4000 | 4000  | 4000 | 4000  | 4000 | 4000  | 4000 | 4000 | 4000  |
| 18.0                             | 4000  | 4000 | 4000  | 4000 | 4000  | 4000 | 4000  | 4000 | 4000  | 4000 | 4000  | 4000 | 4000 | 4000  |
| 18.5                             | 4000  | 4000 | 4000  | 4000 | 4000  | 4000 | 4000  | 4000 | 4000  | 4000 | 4000  | 4000 | 4000 | 4000  |
| 19.0                             | 4000  | 4000 | 4000  | 4000 | 4000  | 4000 | 4000  | 4000 | 4000  | 4000 | 4000  | 4000 | 4000 | 4000  |
| 19.5                             | 4000  | 4000 | 4000  | 4000 | 4000  | 4000 | 4000  | 4000 | 4000  | 4000 | 4000  | 4000 | 4000 | 4000  |
| 20.0                             | 4000  | 4000 | 4000  | 4000 | 4000  | 4000 | 4000  | 4000 | 4000  | 4000 | 4000  | 4000 | 4000 | 4000  |
| 20.5                             | 4000  | 4000 | 4000  | 4000 | 4000  | 4000 | 4000  | 4000 | 4000  | 4000 | 4000  | 4000 | 4000 | 4000  |
| 21.0                             | 4000  | 4000 | 4000  | 4000 | 4000  | 4000 | 4000  | 4000 | 4000  | 4000 | 4000  | 4000 | 4000 | 4000  |
| 21.5                             | 4000  | 4000 | 4000  | 4000 | 4000  | 4000 | 4000  | 4000 | 4000  | 4000 | 4000  | 4000 | 4000 | 4000  |
| 22.0                             | 4000  | 4000 | 4000  | 4000 | 4000  | 4000 | 4000  | 4000 | 4000  | 4000 | 4000  | 4000 | 4000 | 4000  |
| 22.5                             | 4000  | 4000 | 4000  | 4000 | 4000  | 4000 | 4000  | 4000 | 4000  | 4000 | 4000  | 4000 | 4000 | 4000  |
| 23.0                             | 4000  | 4000 | 4000  | 4000 | 4000  | 4000 | 4000  | 4000 | 4000  | 4000 | 4000  | 4000 | 4000 | 4000  |
| 23.5                             | 4000  | 4000 | 4000  | 4000 | 4000  | 4000 | 4000  | 4000 | 4000  | 4000 | 4000  | 4000 | 4000 | 4000  |
| 24.0                             | 4000  | 4000 | 4000  | 4000 | 4000  | 4000 | 4000  | 4000 | 4000  | 4000 | 4000  | 4000 | 4000 | 4000  |
| 24.5                             | 4000  | 4000 | 4000  | 4000 | 4000  | 4000 | 4000  | 4000 | 4000  | 4000 | 4000  | 4000 | 4000 | 4000  |
| 25.0                             | 4000  | 4000 | 4000  | 4000 | 4000  | 4000 | 4000  | 4000 | 4000  | 4000 | 4000  | 4000 | 4000 | 4000  |
| 25.5                             | 4000  | 4000 | 4000  | 4000 | 4000  | 4000 | 4000  | 4000 | 4000  | 4000 | 4000  | 4000 | 4000 | 4000  |
| 26.0                             | 4000  | 4000 | 4000  | 4000 | 4000  | 4000 | 4000  | 4000 | 4000  | 4000 | 4000  | 4000 | 4000 | 4000  |
| 26.5                             | 4000  | 4000 | 4000  | 4000 | 4000  | 4000 | 4000  | 4000 | 4000  | 4000 | 4000  | 4000 | 4000 | 4000  |
| 27.0                             | 4000  | 4000 | 4000  | 4000 | 4000  | 4000 | 4000  | 4000 | 4000  | 4000 | 4000  | 4000 | 4000 | 4000  |

Table 6-1: Power curve, Mode 0/0-0S

## 6.2 Ct Values, Mode 0/0-0S

Air density kg/m<sup>3</sup>

| Wind speed [m/s] | 1.225 | 0.950 | 0.975 | 1.0   | 1.025 | 1.05  | 1.075 | 1.1   | 1.125 | 1.15  | 1.175 | 1.2   | 1.25  | 1.275 |
|------------------|-------|-------|-------|-------|-------|-------|-------|-------|-------|-------|-------|-------|-------|-------|
| 3.0              | 0.873 | 0.878 | 0.877 | 0.877 | 0.876 | 0.876 | 0.876 | 0.875 | 0.875 | 0.874 | 0.874 | 0.874 | 0.873 | 0.873 |
| 3.5              | 0.847 | 0.851 | 0.851 | 0.850 | 0.850 | 0.850 | 0.849 | 0.849 | 0.849 | 0.848 | 0.848 | 0.848 | 0.847 | 0.846 |
| 4.0              | 0.845 | 0.854 | 0.853 | 0.851 | 0.850 | 0.848 | 0.848 | 0.848 | 0.847 | 0.847 | 0.847 | 0.846 | 0.845 | 0.845 |
| 4.5              | 0.843 | 0.842 | 0.842 | 0.843 | 0.843 | 0.843 | 0.843 | 0.843 | 0.844 | 0.844 | 0.843 | 0.843 | 0.843 | 0.843 |
| 5.0              | 0.844 | 0.848 | 0.848 | 0.848 | 0.847 | 0.847 | 0.847 | 0.846 | 0.846 | 0.846 | 0.845 | 0.845 | 0.844 | 0.843 |
| 5.5              | 0.840 | 0.845 | 0.845 | 0.844 | 0.844 | 0.843 | 0.843 | 0.842 | 0.842 | 0.841 | 0.841 | 0.840 | 0.839 | 0.839 |
| 6.0              | 0.834 | 0.840 | 0.840 | 0.839 | 0.839 | 0.838 | 0.838 | 0.837 | 0.836 | 0.836 | 0.835 | 0.835 | 0.834 | 0.833 |
| 6.5              | 0.828 | 0.836 | 0.835 | 0.835 | 0.834 | 0.833 | 0.833 | 0.832 | 0.831 | 0.831 | 0.830 | 0.829 | 0.827 | 0.827 |
| 7.0              | 0.821 | 0.831 | 0.830 | 0.829 | 0.828 | 0.828 | 0.827 | 0.826 | 0.825 | 0.824 | 0.823 | 0.822 | 0.820 | 0.819 |
| 7.5              | 0.814 | 0.825 | 0.824 | 0.823 | 0.822 | 0.822 | 0.820 | 0.819 | 0.818 | 0.817 | 0.816 | 0.815 | 0.813 | 0.812 |
| 8.0              | 0.816 | 0.830 | 0.829 | 0.828 | 0.826 | 0.825 | 0.824 | 0.823 | 0.821 | 0.820 | 0.819 | 0.817 | 0.814 | 0.812 |
| 8.5              | 0.799 | 0.831 | 0.829 | 0.827 | 0.825 | 0.823 | 0.820 | 0.816 | 0.813 | 0.810 | 0.806 | 0.803 | 0.795 | 0.791 |
| 9.0              | 0.746 | 0.807 | 0.802 | 0.798 | 0.793 | 0.788 | 0.782 | 0.776 | 0.771 | 0.765 | 0.759 | 0.752 | 0.739 | 0.733 |
| 9.5              | 0.675 | 0.753 | 0.746 | 0.739 | 0.732 | 0.725 | 0.718 | 0.711 | 0.704 | 0.696 | 0.689 | 0.682 | 0.668 | 0.661 |
| 10.0             | 0.607 | 0.688 | 0.680 | 0.672 | 0.665 | 0.657 | 0.650 | 0.643 | 0.636 | 0.628 | 0.621 | 0.614 | 0.600 | 0.593 |
| 10.5             | 0.542 | 0.626 | 0.619 | 0.611 | 0.604 | 0.597 | 0.589 | 0.582 | 0.575 | 0.567 | 0.559 | 0.551 | 0.534 | 0.525 |
| 11.0             | 0.473 | 0.570 | 0.562 | 0.554 | 0.546 | 0.538 | 0.530 | 0.521 | 0.512 | 0.503 | 0.493 | 0.483 | 0.464 | 0.454 |
| 11.5             | 0.406 | 0.518 | 0.508 | 0.499 | 0.489 | 0.480 | 0.469 | 0.458 | 0.448 | 0.437 | 0.427 | 0.416 | 0.397 | 0.388 |
| 12.0             | 0.349 | 0.464 | 0.453 | 0.441 | 0.430 | 0.418 | 0.408 | 0.397 | 0.386 | 0.376 | 0.367 | 0.358 | 0.341 | 0.333 |
| 12.5             | 0.303 | 0.408 | 0.396 | 0.385 | 0.374 | 0.362 | 0.353 | 0.344 | 0.335 | 0.325 | 0.318 | 0.310 | 0.296 | 0.290 |
| 13.0             | 0.266 | 0.356 | 0.346 | 0.336 | 0.326 | 0.316 | 0.308 | 0.300 | 0.292 | 0.285 | 0.278 | 0.272 | 0.260 | 0.255 |
| 13.5             | 0.236 | 0.313 | 0.305 | 0.296 | 0.288 | 0.279 | 0.273 | 0.266 | 0.259 | 0.253 | 0.247 | 0.242 | 0.232 | 0.227 |
| 14.0             | 0.210 | 0.277 | 0.269 | 0.262 | 0.255 | 0.248 | 0.242 | 0.236 | 0.230 | 0.225 | 0.220 | 0.215 | 0.206 | 0.202 |
| 14.5             | 0.188 | 0.246 | 0.240 | 0.234 | 0.227 | 0.221 | 0.216 | 0.211 | 0.206 | 0.201 | 0.197 | 0.193 | 0.185 | 0.181 |
| 15.0             | 0.169 | 0.220 | 0.214 | 0.209 | 0.203 | 0.198 | 0.193 | 0.189 | 0.184 | 0.180 | 0.176 | 0.173 | 0.166 | 0.162 |
| 15.5             | 0.153 | 0.198 | 0.193 | 0.188 | 0.183 | 0.178 | 0.174 | 0.170 | 0.167 | 0.163 | 0.159 | 0.156 | 0.150 | 0.147 |
| 16.0             | 0.139 | 0.179 | 0.175 | 0.170 | 0.166 | 0.162 | 0.158 | 0.155 | 0.151 | 0.148 | 0.145 | 0.142 | 0.136 | 0.134 |
| 16.5             | 0.127 | 0.163 | 0.159 | 0.155 | 0.151 | 0.147 | 0.144 | 0.141 | 0.138 | 0.135 | 0.132 | 0.129 | 0.124 | 0.122 |
| 17.0             | 0.116 | 0.149 | 0.145 | 0.142 | 0.138 | 0.135 | 0.132 | 0.129 | 0.126 | 0.123 | 0.121 | 0.118 | 0.114 | 0.112 |
| 17.5             | 0.107 | 0.136 | 0.133 | 0.130 | 0.126 | 0.123 | 0.121 | 0.118 | 0.116 | 0.113 | 0.111 | 0.109 | 0.105 | 0.103 |
| 18.0             | 0.098 | 0.125 | 0.122 | 0.119 | 0.116 | 0.113 | 0.111 | 0.109 | 0.106 | 0.104 | 0.102 | 0.100 | 0.096 | 0.095 |
| 18.5             | 0.091 | 0.115 | 0.113 | 0.110 | 0.107 | 0.105 | 0.103 | 0.100 | 0.098 | 0.096 | 0.094 | 0.093 | 0.089 | 0.088 |
| 19.0             | 0.084 | 0.106 | 0.104 | 0.101 | 0.099 | 0.096 | 0.094 | 0.093 | 0.091 | 0.089 | 0.087 | 0.085 | 0.082 | 0.081 |
| 19.5             | 0.078 | 0.098 | 0.096 | 0.094 | 0.092 | 0.089 | 0.088 | 0.086 | 0.084 | 0.082 | 0.081 | 0.079 | 0.077 | 0.075 |
| 20.0             | 0.073 | 0.091 | 0.089 | 0.087 | 0.085 | 0.083 | 0.082 | 0.080 | 0.078 | 0.077 | 0.075 | 0.074 | 0.071 | 0.070 |
| 20.5             | 0.068 | 0.085 | 0.083 | 0.081 | 0.079 | 0.078 | 0.076 | 0.075 | 0.073 | 0.072 | 0.070 | 0.069 | 0.067 | 0.065 |
| 21.0             | 0.063 | 0.079 | 0.078 | 0.076 | 0.074 | 0.073 | 0.071 | 0.070 | 0.068 | 0.067 | 0.066 | 0.065 | 0.062 | 0.061 |
| 21.5             | 0.060 | 0.075 | 0.073 | 0.072 | 0.070 | 0.069 | 0.067 | 0.066 | 0.065 | 0.063 | 0.062 | 0.061 | 0.059 | 0.058 |
| 22.0             | 0.056 | 0.070 | 0.069 | 0.067 | 0.066 | 0.064 | 0.063 | 0.062 | 0.061 | 0.059 | 0.058 | 0.057 | 0.056 | 0.055 |
| 22.5             | 0.053 | 0.066 | 0.065 | 0.063 | 0.062 | 0.060 | 0.059 | 0.058 | 0.057 | 0.056 | 0.055 | 0.054 | 0.052 | 0.051 |
| 23.0             | 0.050 | 0.062 | 0.060 | 0.059 | 0.058 | 0.057 | 0.056 | 0.055 | 0.054 | 0.052 | 0.052 | 0.051 | 0.049 | 0.048 |
| 23.5             | 0.047 | 0.058 | 0.057 | 0.056 | 0.055 | 0.053 | 0.052 | 0.052 | 0.051 | 0.050 | 0.049 | 0.048 | 0.046 | 0.046 |
| 24.0             | 0.045 | 0.055 | 0.054 | 0.053 | 0.052 | 0.051 | 0.050 | 0.049 | 0.048 | 0.047 | 0.046 | 0.045 | 0.044 | 0.043 |
| 24.5             | 0.042 | 0.052 | 0.051 | 0.050 | 0.049 | 0.048 | 0.047 | 0.046 | 0.045 | 0.044 | 0.044 | 0.043 | 0.042 | 0.041 |
| 25.0             | 0.040 | 0.049 | 0.048 | 0.047 | 0.046 | 0.045 | 0.045 | 0.044 | 0.043 | 0.042 | 0.042 | 0.041 | 0.040 | 0.039 |
| 25.5             | 0.038 | 0.047 | 0.046 | 0.045 | 0.044 | 0.043 | 0.043 | 0.042 | 0.041 | 0.040 | 0.040 | 0.039 | 0.038 | 0.037 |
| 26.0             | 0.037 | 0.045 | 0.044 | 0.043 | 0.042 | 0.041 | 0.040 | 0.040 | 0.039 | 0.038 | 0.038 | 0.037 | 0.036 | 0.036 |
| 26.5             | 0.035 | 0.042 | 0.042 | 0.041 | 0.040 | 0.039 | 0.039 | 0.038 | 0.037 | 0.037 | 0.036 | 0.035 | 0.034 | 0.034 |
| 27.0             | 0.033 | 0.041 | 0.040 | 0.039 | 0.038 | 0.037 | 0.037 | 0.036 | 0.036 | 0.035 | 0.034 | 0.034 | 0.033 | 0.032 |

Table 6-2: C<sub>t</sub> values, Mode 0/0-0S

**6.3 Sound Curves, Mode 0/0-0S**

| Sound Power Level at Hub Height   |  |  |
|-----------------------------------|--|--|
| Conditions for Sound Power Level: | Measurement standard IEC 61400-11 ed. 3<br>Maximum turbulence at hub height: 30%<br>Inflow angle (vertical): 0 ±2°<br>Air density: 1.225 kg/m <sup>3</sup> |  |
| Wind speed at hub height [m/s]    | Sound Power Level at Hub Height [dBA]<br>Mode 0 (Blades with serrated trailing edge)   | Sound Power Level at Hub Height [dBA]<br>Mode 0-0S (Blades without serrated trailing edge) |
| 3                                 | 90.9   | 93.1   |
| 4                                 | 91.1   | 93.6   |
| 5                                 | 92.8   | 96.4   |
| 6                                 | 95.9   | 99.9   |
| 7                                 | 99.5   | 103.1  |
| 8                                 | 102.8  | 105.9  |
| 9                                 | 103.9  | 106.9  |
| 10                                | 103.9  | 106.9  |
| 11                                | 103.9  | 106.9  |
| 12                                | 103.9  | 106.9  |
| 13                                | 103.9  | 106.9  |
| 14                                | 103.9  | 106.9  |
| 15                                | 103.9  | 106.9  |
| 16                                | 103.9  | 106.9  |
| 17                                | 103.9  | 106.9  |
| 18                                | 103.9  | 106.9  |
| 19                                | 103.9  | 106.9  |
| 20                                | 103.9  | 106.9  |

Table 6-3: Sound curves, Mode 0/0-0S



## 7 Power Curves, Ct Values and Sound Curves, Mode 0/0-0S (HWO)

**NOTE** The power curves and Ct values presented in Section 7 are only valid for low hub heights, i.e. hub heights ≤ 104 m.

### 7.1 Power Curves, Mode 0/0-0S (HWO)

| Air density [kg/m <sup>3</sup> ] |       |       |       |       |       |       |       |       |       |       |       |       |       |       |
|----------------------------------|-------|-------|-------|-------|-------|-------|-------|-------|-------|-------|-------|-------|-------|-------|
| Wind speed [m/s]                 | 1.225 | 0.950 | 0.975 | 1.000 | 1.025 | 1.050 | 1.075 | 1.100 | 1.125 | 1.150 | 1.175 | 1.200 | 1.250 | 1.275 |
| 3.0                              | 55    | 31    | 33    | 35    | 38    | 40    | 42    | 44    | 46    | 48    | 51    | 53    | 57    | 59    |
| 3.5                              | 130   | 89    | 93    | 97    | 100   | 104   | 108   | 111   | 115   | 119   | 122   | 126   | 133   | 137   |
| 4.0                              | 220   | 159   | 165   | 170   | 176   | 182   | 187   | 193   | 198   | 204   | 209   | 215   | 226   | 231   |
| 4.5                              | 331   | 245   | 253   | 260   | 268   | 276   | 284   | 292   | 299   | 307   | 315   | 323   | 338   | 346   |
| 5.0                              | 471   | 353   | 364   | 374   | 385   | 396   | 407   | 417   | 428   | 439   | 449   | 460   | 481   | 492   |
| 5.5                              | 639   | 483   | 497   | 511   | 526   | 540   | 554   | 568   | 582   | 596   | 610   | 624   | 653   | 667   |
| 6.0                              | 841   | 640   | 659   | 677   | 695   | 714   | 732   | 750   | 768   | 787   | 805   | 823   | 860   | 878   |
| 6.5                              | 1080  | 826   | 849   | 872   | 895   | 919   | 942   | 965   | 988   | 1011  | 1034  | 1057  | 1104  | 1127  |
| 7.0                              | 1361  | 1044  | 1073  | 1102  | 1131  | 1160  | 1189  | 1218  | 1247  | 1276  | 1304  | 1333  | 1390  | 1419  |
| 7.5                              | 1681  | 1293  | 1329  | 1364  | 1399  | 1435  | 1470  | 1505  | 1541  | 1576  | 1611  | 1646  | 1715  | 1750  |
| 8.0                              | 2042  | 1578  | 1620  | 1663  | 1706  | 1748  | 1790  | 1833  | 1875  | 1917  | 1959  | 2000  | 2083  | 2124  |
| 8.5                              | 2441  | 1897  | 1947  | 1998  | 2048  | 2099  | 2148  | 2198  | 2247  | 2296  | 2345  | 2393  | 2488  | 2535  |
| 9.0                              | 2845  | 2242  | 2300  | 2358  | 2415  | 2473  | 2527  | 2582  | 2636  | 2691  | 2742  | 2794  | 2894  | 2943  |
| 9.5                              | 3214  | 2591  | 2652  | 2713  | 2774  | 2836  | 2892  | 2948  | 3004  | 3060  | 3111  | 3163  | 3263  | 3311  |
| 10.0                             | 3547  | 2923  | 2985  | 3048  | 3110  | 3172  | 3228  | 3284  | 3340  | 3396  | 3447  | 3497  | 3592  | 3637  |
| 10.5                             | 3809  | 3228  | 3290  | 3354  | 3416  | 3480  | 3532  | 3585  | 3638  | 3691  | 3731  | 3770  | 3838  | 3867  |
| 11.0                             | 3949  | 3504  | 3561  | 3618  | 3676  | 3733  | 3772  | 3810  | 3849  | 3888  | 3908  | 3929  | 3960  | 3972  |
| 11.5                             | 3992  | 3739  | 3781  | 3824  | 3866  | 3908  | 3925  | 3942  | 3959  | 3976  | 3981  | 3986  | 3994  | 3996  |
| 12.0                             | 3999  | 3902  | 3921  | 3940  | 3960  | 3979  | 3983  | 3988  | 3992  | 3996  | 3997  | 3998  | 3999  | 4000  |
| 12.5                             | 4000  | 3970  | 3977  | 3983  | 3990  | 3996  | 3997  | 3998  | 3999  | 4000  | 4000  | 4000  | 4000  | 4000  |
| 13.0                             | 4000  | 3992  | 3994  | 3996  | 3997  | 3999  | 4000  | 4000  | 4000  | 4000  | 4000  | 4000  | 4000  | 4000  |
| 13.5                             | 4000  | 3994  | 3995  | 3997  | 3998  | 3999  | 4000  | 4000  | 4000  | 4000  | 4000  | 4000  | 4000  | 4000  |
| 14.0                             | 4000  | 3998  | 3998  | 3999  | 3999  | 4000  | 4000  | 4000  | 4000  | 4000  | 4000  | 4000  | 4000  | 4000  |
| 14.5                             | 4000  | 3999  | 4000  | 4000  | 4000  | 4000  | 4000  | 4000  | 4000  | 4000  | 4000  | 4000  | 4000  | 4000  |
| 15.0                             | 4000  | 3999  | 3999  | 4000  | 4000  | 4000  | 4000  | 4000  | 4000  | 4000  | 4000  | 4000  | 4000  | 4000  |
| 15.5                             | 4000  | 4000  | 4000  | 4000  | 4000  | 4000  | 4000  | 4000  | 4000  | 4000  | 4000  | 4000  | 4000  | 4000  |
| 16.0                             | 4000  | 4000  | 4000  | 4000  | 4000  | 4000  | 4000  | 4000  | 4000  | 4000  | 4000  | 4000  | 4000  | 4000  |
| 16.5                             | 4000  | 4000  | 4000  | 4000  | 4000  | 4000  | 4000  | 4000  | 4000  | 4000  | 4000  | 4000  | 4000  | 4000  |
| 17.0                             | 4000  | 4000  | 4000  | 4000  | 4000  | 4000  | 4000  | 4000  | 4000  | 4000  | 4000  | 4000  | 4000  | 4000  |
| 17.5                             | 4000  | 4000  | 4000  | 4000  | 4000  | 4000  | 4000  | 4000  | 4000  | 4000  | 4000  | 4000  | 4000  | 4000  |
| 18.0                             | 4000  | 4000  | 4000  | 4000  | 4000  | 4000  | 4000  | 4000  | 4000  | 4000  | 4000  | 4000  | 4000  | 4000  |
| 18.5                             | 4000  | 4000  | 4000  | 4000  | 4000  | 4000  | 4000  | 4000  | 4000  | 4000  | 4000  | 4000  | 4000  | 4000  |
| 19.0                             | 4000  | 4000  | 4000  | 4000  | 4000  | 4000  | 4000  | 4000  | 4000  | 4000  | 4000  | 4000  | 4000  | 4000  |
| 19.5                             | 4000  | 4000  | 4000  | 4000  | 4000  | 4000  | 4000  | 4000  | 4000  | 4000  | 4000  | 4000  | 4000  | 4000  |
| 20.0                             | 4000  | 4000  | 4000  | 4000  | 4000  | 4000  | 4000  | 4000  | 4000  | 4000  | 4000  | 4000  | 4000  | 4000  |
| 20.5                             | 4000  | 4000  | 4000  | 4000  | 4000  | 4000  | 4000  | 4000  | 4000  | 4000  | 4000  | 4000  | 4000  | 4000  |
| 21.0                             | 4000  | 4000  | 4000  | 4000  | 4000  | 4000  | 4000  | 4000  | 4000  | 4000  | 4000  | 4000  | 4000  | 4000  |
| 21.5                             | 4000  | 4000  | 4000  | 4000  | 4000  | 4000  | 4000  | 4000  | 4000  | 4000  | 4000  | 4000  | 4000  | 4000  |
| 22.0                             | 4000  | 4000  | 4000  | 4000  | 4000  | 4000  | 4000  | 4000  | 4000  | 4000  | 4000  | 4000  | 4000  | 4000  |
| 22.5                             | 4000  | 4000  | 4000  | 4000  | 4000  | 4000  | 4000  | 4000  | 4000  | 4000  | 4000  | 4000  | 4000  | 4000  |
| 23.0                             | 4000  | 4000  | 4000  | 4000  | 4000  | 4000  | 4000  | 4000  | 4000  | 4000  | 4000  | 4000  | 4000  | 4000  |
| 23.5                             | 4000  | 4000  | 4000  | 4000  | 4000  | 4000  | 4000  | 4000  | 4000  | 4000  | 4000  | 4000  | 4000  | 4000  |
| 24.0                             | 4000  | 4000  | 4000  | 4000  | 4000  | 4000  | 4000  | 4000  | 4000  | 4000  | 4000  | 4000  | 4000  | 4000  |
| 24.5                             | 4000  | 4000  | 4000  | 4000  | 4000  | 4000  | 4000  | 4000  | 4000  | 4000  | 4000  | 4000  | 4000  | 4000  |
| 25.0                             | 3998  | 3998  | 3998  | 3998  | 3998  | 3998  | 3998  | 3998  | 3998  | 3998  | 3998  | 3998  | 3998  | 3998  |
| 25.5                             | 3976  | 3976  | 3976  | 3976  | 3976  | 3976  | 3976  | 3976  | 3976  | 3976  | 3976  | 3976  | 3976  | 3976  |
| 26.0                             | 3928  | 3928  | 3928  | 3928  | 3928  | 3928  | 3928  | 3928  | 3928  | 3928  | 3928  | 3928  | 3928  | 3928  |
| 26.5                             | 3857  | 3857  | 3857  | 3857  | 3857  | 3857  | 3857  | 3857  | 3857  | 3857  | 3857  | 3857  | 3857  | 3857  |
| 27.0                             | 3763  | 3763  | 3763  | 3763  | 3763  | 3763  | 3763  | 3763  | 3763  | 3763  | 3763  | 3763  | 3763  | 3763  |
| 27.5                             | 3630  | 3630  | 3630  | 3630  | 3630  | 3630  | 3630  | 3630  | 3630  | 3630  | 3630  | 3630  | 3630  | 3630  |
| 28.0                             | 3468  | 3468  | 3468  | 3468  | 3468  | 3468  | 3468  | 3468  | 3468  | 3468  | 3468  | 3468  | 3468  | 3468  |

| Air density [kg/m <sup>3</sup> ] |             |       |       |       |       |       |       |       |       |       |       |       |       |       |
|----------------------------------|-------------|-------|-------|-------|-------|-------|-------|-------|-------|-------|-------|-------|-------|-------|
| Wind speed [m/s]                 | 1.225       | 0.950 | 0.975 | 1.000 | 1.025 | 1.050 | 1.075 | 1.100 | 1.125 | 1.150 | 1.175 | 1.200 | 1.250 | 1.275 |
| <b>28.5</b>                      | <b>3275</b> | 3275  | 3275  | 3275  | 3275  | 3275  | 3275  | 3275  | 3275  | 3275  | 3275  | 3275  | 3275  | 3275  |
| <b>29.0</b>                      | <b>3049</b> | 3049  | 3049  | 3049  | 3049  | 3049  | 3049  | 3049  | 3049  | 3049  | 3049  | 3049  | 3049  | 3049  |
| <b>29.5</b>                      | <b>2806</b> | 2806  | 2806  | 2806  | 2806  | 2806  | 2806  | 2806  | 2806  | 2806  | 2806  | 2806  | 2806  | 2806  |
| <b>30.0</b>                      | <b>2565</b> | 2565  | 2565  | 2565  | 2565  | 2565  | 2565  | 2565  | 2565  | 2565  | 2565  | 2565  | 2565  | 2565  |
| <b>30.5</b>                      | <b>2324</b> | 2324  | 2324  | 2324  | 2324  | 2324  | 2324  | 2324  | 2324  | 2325  | 2325  | 2325  | 2325  | 2324  |
| <b>31.0</b>                      | <b>2090</b> | 2090  | 2090  | 2090  | 2090  | 2090  | 2090  | 2090  | 2090  | 2090  | 2090  | 2090  | 2090  | 2090  |
| <b>31.5</b>                      | <b>1884</b> | 1884  | 1884  | 1884  | 1884  | 1884  | 1884  | 1884  | 1884  | 1884  | 1884  | 1884  | 1884  | 1884  |
| <b>32.0</b>                      | <b>1732</b> | 1732  | 1732  | 1732  | 1732  | 1732  | 1732  | 1732  | 1732  | 1732  | 1732  | 1732  | 1732  | 1732  |

*Table 7-1: Power curve, Mode 0/0-0S (HWO)*

**7.2 Ct Values, Mode 0/0-0S (HWO)**

| Air density kg/m <sup>3</sup> |       |       |       |       |       |       |       |       |       |       |       |       |       |       |
|-------------------------------|-------|-------|-------|-------|-------|-------|-------|-------|-------|-------|-------|-------|-------|-------|
| Wind speed [m/s]              | 1.225 | 0.950 | 0.975 | 1.000 | 1.025 | 1.050 | 1.075 | 1.100 | 1.125 | 1.150 | 1.175 | 1.200 | 1.250 | 1.275 |
| 3.0                           | 0.873 | 0.878 | 0.877 | 0.877 | 0.876 | 0.876 | 0.876 | 0.875 | 0.875 | 0.874 | 0.874 | 0.874 | 0.873 | 0.873 |
| 3.5                           | 0.847 | 0.851 | 0.851 | 0.850 | 0.850 | 0.850 | 0.849 | 0.849 | 0.849 | 0.848 | 0.848 | 0.848 | 0.847 | 0.846 |
| 4.0                           | 0.845 | 0.854 | 0.853 | 0.851 | 0.850 | 0.848 | 0.848 | 0.848 | 0.847 | 0.847 | 0.847 | 0.846 | 0.845 | 0.845 |
| 4.5                           | 0.843 | 0.842 | 0.842 | 0.843 | 0.843 | 0.843 | 0.843 | 0.843 | 0.844 | 0.844 | 0.843 | 0.843 | 0.843 | 0.843 |
| 5.0                           | 0.844 | 0.848 | 0.848 | 0.848 | 0.847 | 0.847 | 0.847 | 0.846 | 0.846 | 0.846 | 0.845 | 0.845 | 0.844 | 0.843 |
| 5.5                           | 0.840 | 0.845 | 0.845 | 0.844 | 0.844 | 0.843 | 0.843 | 0.842 | 0.842 | 0.841 | 0.841 | 0.840 | 0.839 | 0.839 |
| 6.0                           | 0.834 | 0.840 | 0.840 | 0.839 | 0.839 | 0.838 | 0.838 | 0.837 | 0.836 | 0.836 | 0.835 | 0.835 | 0.834 | 0.833 |
| 6.5                           | 0.828 | 0.836 | 0.835 | 0.835 | 0.834 | 0.833 | 0.833 | 0.832 | 0.831 | 0.831 | 0.830 | 0.829 | 0.827 | 0.827 |
| 7.0                           | 0.821 | 0.831 | 0.830 | 0.829 | 0.828 | 0.828 | 0.827 | 0.826 | 0.825 | 0.824 | 0.823 | 0.822 | 0.820 | 0.819 |
| 7.5                           | 0.814 | 0.825 | 0.824 | 0.823 | 0.822 | 0.822 | 0.820 | 0.819 | 0.818 | 0.817 | 0.816 | 0.815 | 0.813 | 0.812 |
| 8.0                           | 0.816 | 0.830 | 0.829 | 0.828 | 0.826 | 0.825 | 0.824 | 0.823 | 0.821 | 0.820 | 0.819 | 0.817 | 0.814 | 0.812 |
| 8.5                           | 0.799 | 0.831 | 0.829 | 0.827 | 0.825 | 0.823 | 0.820 | 0.816 | 0.813 | 0.810 | 0.806 | 0.803 | 0.795 | 0.791 |
| 9.0                           | 0.746 | 0.807 | 0.802 | 0.798 | 0.793 | 0.788 | 0.782 | 0.776 | 0.771 | 0.765 | 0.759 | 0.752 | 0.739 | 0.733 |
| 9.5                           | 0.675 | 0.753 | 0.746 | 0.739 | 0.732 | 0.725 | 0.718 | 0.711 | 0.704 | 0.696 | 0.689 | 0.682 | 0.668 | 0.661 |
| 10.0                          | 0.607 | 0.688 | 0.680 | 0.672 | 0.665 | 0.657 | 0.650 | 0.643 | 0.636 | 0.628 | 0.621 | 0.614 | 0.600 | 0.593 |
| 10.5                          | 0.542 | 0.626 | 0.619 | 0.611 | 0.604 | 0.597 | 0.589 | 0.582 | 0.575 | 0.567 | 0.559 | 0.551 | 0.534 | 0.525 |
| 11.0                          | 0.473 | 0.570 | 0.562 | 0.554 | 0.546 | 0.538 | 0.530 | 0.521 | 0.512 | 0.503 | 0.493 | 0.483 | 0.464 | 0.454 |
| 11.5                          | 0.406 | 0.518 | 0.508 | 0.499 | 0.489 | 0.480 | 0.469 | 0.458 | 0.448 | 0.437 | 0.427 | 0.416 | 0.397 | 0.388 |
| 12.0                          | 0.349 | 0.464 | 0.453 | 0.441 | 0.430 | 0.418 | 0.408 | 0.397 | 0.386 | 0.376 | 0.367 | 0.358 | 0.341 | 0.333 |
| 12.5                          | 0.303 | 0.408 | 0.396 | 0.385 | 0.374 | 0.362 | 0.353 | 0.344 | 0.335 | 0.325 | 0.318 | 0.310 | 0.296 | 0.290 |
| 13.0                          | 0.266 | 0.356 | 0.346 | 0.336 | 0.326 | 0.316 | 0.308 | 0.300 | 0.292 | 0.285 | 0.278 | 0.272 | 0.260 | 0.255 |
| 13.5                          | 0.236 | 0.313 | 0.305 | 0.296 | 0.288 | 0.279 | 0.273 | 0.266 | 0.259 | 0.253 | 0.247 | 0.242 | 0.232 | 0.227 |
| 14.0                          | 0.210 | 0.277 | 0.269 | 0.262 | 0.255 | 0.248 | 0.242 | 0.236 | 0.230 | 0.225 | 0.220 | 0.215 | 0.206 | 0.202 |
| 14.5                          | 0.188 | 0.246 | 0.240 | 0.234 | 0.227 | 0.221 | 0.216 | 0.211 | 0.206 | 0.201 | 0.197 | 0.193 | 0.185 | 0.181 |
| 15.0                          | 0.169 | 0.220 | 0.214 | 0.209 | 0.203 | 0.198 | 0.193 | 0.189 | 0.184 | 0.180 | 0.176 | 0.173 | 0.166 | 0.162 |
| 15.5                          | 0.153 | 0.198 | 0.193 | 0.188 | 0.183 | 0.178 | 0.174 | 0.170 | 0.167 | 0.163 | 0.159 | 0.156 | 0.150 | 0.147 |
| 16.0                          | 0.139 | 0.179 | 0.175 | 0.170 | 0.166 | 0.162 | 0.158 | 0.155 | 0.151 | 0.148 | 0.145 | 0.142 | 0.136 | 0.134 |
| 16.5                          | 0.127 | 0.163 | 0.159 | 0.155 | 0.151 | 0.147 | 0.144 | 0.141 | 0.138 | 0.135 | 0.132 | 0.129 | 0.124 | 0.122 |
| 17.0                          | 0.116 | 0.149 | 0.145 | 0.142 | 0.138 | 0.135 | 0.132 | 0.129 | 0.126 | 0.123 | 0.121 | 0.118 | 0.114 | 0.112 |
| 17.5                          | 0.107 | 0.136 | 0.133 | 0.130 | 0.126 | 0.123 | 0.121 | 0.118 | 0.116 | 0.113 | 0.111 | 0.109 | 0.105 | 0.103 |
| 18.0                          | 0.098 | 0.125 | 0.122 | 0.119 | 0.116 | 0.113 | 0.111 | 0.109 | 0.106 | 0.104 | 0.102 | 0.100 | 0.096 | 0.095 |
| 18.5                          | 0.091 | 0.115 | 0.113 | 0.110 | 0.107 | 0.105 | 0.103 | 0.100 | 0.098 | 0.096 | 0.094 | 0.093 | 0.089 | 0.088 |
| 19.0                          | 0.084 | 0.106 | 0.104 | 0.101 | 0.099 | 0.096 | 0.094 | 0.093 | 0.091 | 0.089 | 0.087 | 0.085 | 0.082 | 0.081 |
| 19.5                          | 0.078 | 0.098 | 0.096 | 0.094 | 0.092 | 0.089 | 0.088 | 0.086 | 0.084 | 0.082 | 0.081 | 0.079 | 0.077 | 0.075 |
| 20.0                          | 0.073 | 0.091 | 0.089 | 0.087 | 0.085 | 0.083 | 0.082 | 0.080 | 0.078 | 0.077 | 0.075 | 0.074 | 0.071 | 0.070 |
| 20.5                          | 0.068 | 0.085 | 0.083 | 0.081 | 0.079 | 0.078 | 0.076 | 0.075 | 0.073 | 0.072 | 0.070 | 0.069 | 0.067 | 0.065 |
| 21.0                          | 0.063 | 0.079 | 0.078 | 0.076 | 0.074 | 0.073 | 0.071 | 0.070 | 0.068 | 0.067 | 0.066 | 0.065 | 0.062 | 0.061 |
| 21.5                          | 0.060 | 0.075 | 0.073 | 0.072 | 0.070 | 0.069 | 0.067 | 0.066 | 0.065 | 0.063 | 0.062 | 0.061 | 0.059 | 0.058 |
| 22.0                          | 0.056 | 0.070 | 0.069 | 0.067 | 0.066 | 0.064 | 0.063 | 0.062 | 0.061 | 0.059 | 0.058 | 0.057 | 0.056 | 0.055 |
| 22.5                          | 0.053 | 0.066 | 0.065 | 0.063 | 0.062 | 0.060 | 0.059 | 0.058 | 0.057 | 0.056 | 0.055 | 0.054 | 0.052 | 0.051 |
| 23.0                          | 0.050 | 0.062 | 0.060 | 0.059 | 0.058 | 0.057 | 0.056 | 0.055 | 0.054 | 0.052 | 0.052 | 0.051 | 0.049 | 0.048 |
| 23.5                          | 0.047 | 0.058 | 0.057 | 0.056 | 0.055 | 0.053 | 0.052 | 0.052 | 0.051 | 0.050 | 0.049 | 0.048 | 0.046 | 0.046 |
| 24.0                          | 0.045 | 0.055 | 0.054 | 0.053 | 0.052 | 0.051 | 0.050 | 0.049 | 0.048 | 0.047 | 0.046 | 0.045 | 0.044 | 0.043 |
| 24.5                          | 0.042 | 0.052 | 0.051 | 0.050 | 0.049 | 0.048 | 0.047 | 0.046 | 0.045 | 0.044 | 0.044 | 0.043 | 0.042 | 0.041 |
| 25.0                          | 0.040 | 0.049 | 0.048 | 0.047 | 0.046 | 0.045 | 0.045 | 0.044 | 0.043 | 0.042 | 0.041 | 0.041 | 0.040 | 0.039 |
| 25.5                          | 0.038 | 0.047 | 0.046 | 0.045 | 0.044 | 0.043 | 0.042 | 0.042 | 0.041 | 0.040 | 0.039 | 0.039 | 0.038 | 0.037 |
| 26.0                          | 0.036 | 0.044 | 0.043 | 0.042 | 0.041 | 0.040 | 0.040 | 0.039 | 0.038 | 0.038 | 0.037 | 0.036 | 0.035 | 0.035 |
| 26.5                          | 0.033 | 0.041 | 0.040 | 0.039 | 0.038 | 0.038 | 0.037 | 0.036 | 0.036 | 0.035 | 0.035 | 0.034 | 0.033 | 0.033 |
| 27.0                          | 0.031 | 0.038 | 0.037 | 0.036 | 0.036 | 0.035 | 0.034 | 0.034 | 0.033 | 0.033 | 0.032 | 0.032 | 0.031 | 0.030 |
| 27.5                          | 0.029 | 0.035 | 0.034 | 0.034 | 0.033 | 0.032 | 0.032 | 0.031 | 0.031 | 0.030 | 0.030 | 0.029 | 0.028 | 0.028 |
| 28.0                          | 0.026 | 0.032 | 0.031 | 0.031 | 0.030 | 0.029 | 0.029 | 0.028 | 0.028 | 0.028 | 0.027 | 0.027 | 0.026 | 0.026 |
| 28.5                          | 0.024 | 0.029 | 0.028 | 0.028 | 0.027 | 0.027 | 0.026 | 0.026 | 0.025 | 0.025 | 0.025 | 0.024 | 0.023 | 0.023 |
| 29.0                          | 0.021 | 0.026 | 0.025 | 0.025 | 0.024 | 0.024 | 0.024 | 0.023 | 0.023 | 0.022 | 0.022 | 0.022 | 0.021 | 0.021 |
| 29.5                          | 0.019 | 0.023 | 0.023 | 0.022 | 0.022 | 0.021 | 0.021 | 0.021 | 0.020 | 0.020 | 0.020 | 0.019 | 0.019 | 0.019 |
| 30.0                          | 0.017 | 0.020 | 0.020 | 0.020 | 0.019 | 0.019 | 0.018 | 0.018 | 0.018 | 0.018 | 0.017 | 0.017 | 0.017 | 0.016 |
| 30.5                          | 0.015 | 0.018 | 0.017 | 0.017 | 0.017 | 0.016 | 0.016 | 0.016 | 0.016 | 0.015 | 0.015 | 0.015 | 0.015 | 0.014 |
| 31.0                          | 0.013 | 0.015 | 0.015 | 0.015 | 0.015 | 0.014 | 0.014 | 0.014 | 0.014 | 0.013 | 0.013 | 0.013 | 0.013 | 0.013 |
| 31.5                          | 0.011 | 0.014 | 0.013 | 0.013 | 0.013 | 0.013 | 0.012 | 0.012 | 0.012 | 0.012 | 0.012 | 0.012 | 0.011 | 0.011 |
| 32.0                          | 0.010 | 0.012 | 0.012 | 0.012 | 0.012 | 0.011 | 0.011 | 0.011 | 0.011 | 0.011 | 0.010 | 0.010 | 0.010 | 0.010 |

Table 7-2: C<sub>t</sub> values, Mode 0/0-0S (HWO)

**7.3 Sound Curves, Mode 0/0-0S (HWO)**

| Sound Power Level at Hub Height   |  |  |
|-----------------------------------|--|--|
| Conditions for Sound Power Level: | Measurement standard IEC 61400-11 ed. 3<br>Maximum turbulence at hub height: 30%<br>Inflow angle (vertical): 0 ±2°<br>Air density: 1.225 kg/m <sup>3</sup> |  |
| Wind speed at hub height [m/s]    | Sound Power Level at Hub Height [dBA]<br>Mode 0 (HWO) (Blades with serrated trailing edge)   | Sound Power Level at Hub Height [dBA]<br>Mode 0-0S (HWO) (Blades without serrated trailing edge) |
| 3                                 | 90.9   | 93.1   |
| 4                                 | 91.1   | 93.6   |
| 5                                 | 92.8   | 96.4   |
| 6                                 | 95.9   | 99.9   |
| 7                                 | 99.5   | 103.1  |
| 8                                 | 102.8  | 105.9  |
| 9                                 | 103.9  | 106.9  |
| 10                                | 103.9  | 106.9  |
| 11                                | 103.9  | 106.9  |
| 12                                | 103.9  | 106.9  |
| 13                                | 103.9  | 106.9  |
| 14                                | 103.9  | 106.9  |
| 15                                | 103.9  | 106.9  |
| 16                                | 103.9  | 106.9  |
| 17                                | 103.9  | 106.9  |
| 18                                | 103.9  | 106.9  |
| 19                                | 103.9  | 106.9  |
| 20                                | 103.9  | 106.9  |

Table 7-3: Sound curves, Mode 0/0-0S (HWO)

## 8 Power Curves, Ct Values and Sound Curves, Power Optimized Mode PO1/PO1-0S

**NOTE** The power curves and Ct values presented in Section 8 are only valid for low hub heights, i.e. hub heights ≤ 104 m.

### 8.1 Power Curves, Power Optimized Mode PO1/PO1-0S

| Wind speed [m/s] | Air density [kg/m <sup>3</sup> ] |      |       |      |       |      |       |      |       |      |       |      |      |       |
|------------------|----------------------------------|------|-------|------|-------|------|-------|------|-------|------|-------|------|------|-------|
|                  | 1.225                            | 0.95 | 0.975 | 1.0  | 1.025 | 1.05 | 1.075 | 1.1  | 1.125 | 1.15 | 1.175 | 1.2  | 1.25 | 1.275 |
| 3.0              | 55                               | 31   | 33    | 35   | 38    | 40   | 42    | 44   | 46    | 48   | 51    | 53   | 57   | 59    |
| 3.5              | 130                              | 89   | 93    | 97   | 100   | 104  | 108   | 111  | 115   | 119  | 122   | 126  | 133  | 137   |
| 4.0              | 220                              | 159  | 165   | 170  | 176   | 182  | 187   | 193  | 198   | 204  | 209   | 215  | 226  | 231   |
| 4.5              | 331                              | 245  | 253   | 260  | 268   | 276  | 284   | 292  | 299   | 307  | 315   | 323  | 338  | 346   |
| 5.0              | 471                              | 353  | 364   | 374  | 385   | 396  | 407   | 417  | 428   | 439  | 449   | 460  | 481  | 492   |
| 5.5              | 639                              | 483  | 497   | 512  | 526   | 540  | 554   | 568  | 582   | 596  | 610   | 624  | 653  | 667   |
| 6.0              | 841                              | 640  | 659   | 677  | 695   | 714  | 732   | 750  | 768   | 787  | 805   | 823  | 860  | 878   |
| 6.5              | 1080                             | 826  | 849   | 872  | 895   | 919  | 942   | 965  | 988   | 1011 | 1034  | 1057 | 1104 | 1127  |
| 7.0              | 1362                             | 1044 | 1073  | 1102 | 1131  | 1160 | 1189  | 1218 | 1247  | 1276 | 1304  | 1333 | 1390 | 1419  |
| 7.5              | 1681                             | 1293 | 1329  | 1364 | 1399  | 1435 | 1470  | 1505 | 1541  | 1576 | 1611  | 1646 | 1715 | 1750  |
| 8.0              | 2042                             | 1578 | 1620  | 1663 | 1706  | 1748 | 1790  | 1833 | 1875  | 1917 | 1959  | 2000 | 2083 | 2124  |
| 8.5              | 2441                             | 1897 | 1947  | 1998 | 2048  | 2099 | 2148  | 2198 | 2247  | 2297 | 2345  | 2393 | 2488 | 2535  |
| 9.0              | 2845                             | 2242 | 2300  | 2358 | 2415  | 2473 | 2527  | 2582 | 2636  | 2691 | 2742  | 2794 | 2894 | 2943  |
| 9.5              | 3214                             | 2591 | 2652  | 2713 | 2774  | 2836 | 2891  | 2947 | 3003  | 3059 | 3111  | 3162 | 3262 | 3311  |
| 10.0             | 3547                             | 2923 | 2985  | 3047 | 3110  | 3172 | 3228  | 3284 | 3340  | 3396 | 3446  | 3497 | 3593 | 3640  |
| 10.5             | 3832                             | 3227 | 3290  | 3353 | 3416  | 3479 | 3533  | 3587 | 3641  | 3696 | 3741  | 3787 | 3869 | 3906  |
| 11.0             | 4025                             | 3504 | 3563  | 3623 | 3682  | 3742 | 3788  | 3833 | 3879  | 3924 | 3958  | 3992 | 4051 | 4077  |
| 11.5             | 4143                             | 3748 | 3799  | 3851 | 3902  | 3954 | 3987  | 4020 | 4054  | 4087 | 4106  | 4124 | 4155 | 4166  |
| 12.0             | 4188                             | 3942 | 3981  | 4019 | 4057  | 4096 | 4113  | 4131 | 4149  | 4166 | 4174  | 4181 | 4191 | 4194  |
| 12.5             | 4198                             | 4074 | 4097  | 4119 | 4142  | 4164 | 4171  | 4179 | 4186  | 4193 | 4195  | 4197 | 4199 | 4199  |
| 13.0             | 4200                             | 4144 | 4156  | 4167 | 4178  | 4190 | 4192  | 4194 | 4196  | 4199 | 4199  | 4199 | 4200 | 4200  |
| 13.5             | 4200                             | 4165 | 4172  | 4179 | 4186  | 4193 | 4194  | 4196 | 4198  | 4199 | 4199  | 4200 | 4200 | 4200  |
| 14.0             | 4200                             | 4183 | 4187  | 4190 | 4194  | 4198 | 4198  | 4199 | 4199  | 4200 | 4200  | 4200 | 4200 | 4200  |
| 14.5             | 4200                             | 4193 | 4194  | 4196 | 4197  | 4199 | 4199  | 4199 | 4200  | 4200 | 4200  | 4200 | 4200 | 4200  |
| 15.0             | 4200                             | 4194 | 4195  | 4196 | 4197  | 4198 | 4199  | 4199 | 4200  | 4200 | 4200  | 4200 | 4200 | 4200  |
| 15.5             | 4200                             | 4196 | 4197  | 4198 | 4198  | 4199 | 4199  | 4200 | 4200  | 4200 | 4200  | 4200 | 4200 | 4200  |
| 16.0             | 4200                             | 4198 | 4198  | 4199 | 4199  | 4200 | 4200  | 4200 | 4200  | 4200 | 4200  | 4200 | 4200 | 4200  |
| 16.5             | 4200                             | 4198 | 4199  | 4199 | 4200  | 4200 | 4200  | 4200 | 4200  | 4200 | 4200  | 4200 | 4200 | 4200  |
| 17.0             | 4200                             | 4199 | 4199  | 4199 | 4200  | 4200 | 4200  | 4200 | 4200  | 4200 | 4200  | 4200 | 4200 | 4200  |
| 17.5             | 4200                             | 4200 | 4200  | 4200 | 4200  | 4200 | 4200  | 4200 | 4200  | 4200 | 4200  | 4200 | 4200 | 4200  |
| 18.0             | 4200                             | 4200 | 4200  | 4200 | 4200  | 4200 | 4200  | 4200 | 4200  | 4200 | 4200  | 4200 | 4200 | 4200  |
| 18.5             | 4200                             | 4200 | 4200  | 4200 | 4200  | 4200 | 4200  | 4200 | 4200  | 4200 | 4200  | 4200 | 4200 | 4200  |
| 19.0             | 4200                             | 4200 | 4200  | 4200 | 4200  | 4200 | 4200  | 4200 | 4200  | 4200 | 4200  | 4200 | 4200 | 4200  |
| 19.5             | 4200                             | 4200 | 4200  | 4200 | 4200  | 4200 | 4200  | 4200 | 4200  | 4200 | 4200  | 4200 | 4200 | 4200  |
| 20.0             | 4200                             | 4200 | 4200  | 4200 | 4200  | 4200 | 4200  | 4200 | 4200  | 4200 | 4200  | 4200 | 4200 | 4200  |
| 20.5             | 4200                             | 4200 | 4200  | 4200 | 4200  | 4200 | 4200  | 4200 | 4200  | 4200 | 4200  | 4200 | 4200 | 4200  |
| 21.0             | 4200                             | 4200 | 4200  | 4200 | 4200  | 4200 | 4200  | 4200 | 4200  | 4200 | 4200  | 4200 | 4200 | 4200  |
| 21.5             | 4200                             | 4200 | 4200  | 4200 | 4200  | 4200 | 4200  | 4200 | 4200  | 4200 | 4200  | 4200 | 4200 | 4200  |
| 22.0             | 4200                             | 4200 | 4200  | 4200 | 4200  | 4200 | 4200  | 4200 | 4200  | 4200 | 4200  | 4200 | 4200 | 4200  |
| 22.5             | 4200                             | 4200 | 4200  | 4200 | 4200  | 4200 | 4200  | 4200 | 4200  | 4200 | 4200  | 4200 | 4200 | 4200  |
| 23.0             | 4200                             | 4200 | 4200  | 4200 | 4200  | 4200 | 4200  | 4200 | 4200  | 4200 | 4200  | 4200 | 4200 | 4200  |
| 23.5             | 4200                             | 4200 | 4200  | 4200 | 4200  | 4200 | 4200  | 4200 | 4200  | 4200 | 4200  | 4200 | 4200 | 4200  |
| 24.0             | 4200                             | 4200 | 4200  | 4200 | 4200  | 4200 | 4200  | 4200 | 4200  | 4200 | 4200  | 4200 | 4200 | 4200  |
| 24.5             | 4200                             | 4200 | 4200  | 4200 | 4200  | 4200 | 4200  | 4200 | 4200  | 4200 | 4200  | 4200 | 4200 | 4200  |
| 25.0             | 4200                             | 4200 | 4200  | 4200 | 4200  | 4200 | 4200  | 4200 | 4200  | 4200 | 4200  | 4200 | 4200 | 4200  |
| 25.5             | 4200                             | 4200 | 4200  | 4200 | 4200  | 4200 | 4200  | 4200 | 4200  | 4200 | 4200  | 4200 | 4200 | 4200  |
| 26.0             | 4200                             | 4200 | 4200  | 4200 | 4200  | 4200 | 4200  | 4200 | 4200  | 4200 | 4200  | 4200 | 4200 | 4200  |
| 26.5             | 4200                             | 4200 | 4200  | 4200 | 4200  | 4200 | 4200  | 4200 | 4200  | 4200 | 4200  | 4200 | 4200 | 4200  |
| 27.0             | 4200                             | 4200 | 4200  | 4200 | 4200  | 4200 | 4200  | 4200 | 4200  | 4200 | 4200  | 4200 | 4200 | 4200  |

Table 8-1: Power curve, Power Optimized Mode PO1/PO1-0S

## 8.2 Ct Values, Power Optimized Mode PO1/PO1-0S

| Air density kg/m <sup>3</sup> |       |       |       |       |       |       |       |       |       |       |       |       |       |       |
|-------------------------------|-------|-------|-------|-------|-------|-------|-------|-------|-------|-------|-------|-------|-------|-------|
| Wind speed [m/s]              | 1.225 | 0.950 | 0.975 | 1.0   | 1.025 | 1.05  | 1.075 | 1.1   | 1.125 | 1.15  | 1.175 | 1.2   | 1.25  | 1.275 |
| 3.0                           | 0.873 | 0.878 | 0.877 | 0.877 | 0.876 | 0.876 | 0.876 | 0.875 | 0.875 | 0.874 | 0.874 | 0.874 | 0.873 | 0.873 |
| 3.5                           | 0.847 | 0.851 | 0.851 | 0.850 | 0.850 | 0.850 | 0.849 | 0.849 | 0.849 | 0.848 | 0.848 | 0.848 | 0.847 | 0.846 |
| 4.0                           | 0.845 | 0.854 | 0.853 | 0.851 | 0.850 | 0.848 | 0.848 | 0.848 | 0.847 | 0.847 | 0.847 | 0.846 | 0.845 | 0.845 |
| 4.5                           | 0.843 | 0.842 | 0.842 | 0.843 | 0.843 | 0.843 | 0.843 | 0.843 | 0.843 | 0.844 | 0.843 | 0.843 | 0.843 | 0.843 |
| 5.0                           | 0.844 | 0.848 | 0.848 | 0.848 | 0.847 | 0.847 | 0.847 | 0.846 | 0.846 | 0.845 | 0.845 | 0.845 | 0.844 | 0.843 |
| 5.5                           | 0.840 | 0.845 | 0.845 | 0.844 | 0.844 | 0.843 | 0.843 | 0.842 | 0.842 | 0.841 | 0.841 | 0.840 | 0.839 | 0.839 |
| 6.0                           | 0.834 | 0.840 | 0.840 | 0.839 | 0.839 | 0.838 | 0.838 | 0.837 | 0.837 | 0.836 | 0.835 | 0.835 | 0.834 | 0.833 |
| 6.5                           | 0.828 | 0.836 | 0.835 | 0.835 | 0.834 | 0.833 | 0.833 | 0.832 | 0.831 | 0.831 | 0.830 | 0.829 | 0.827 | 0.826 |
| 7.0                           | 0.821 | 0.831 | 0.830 | 0.829 | 0.828 | 0.828 | 0.827 | 0.826 | 0.825 | 0.824 | 0.823 | 0.822 | 0.820 | 0.819 |
| 7.5                           | 0.814 | 0.825 | 0.824 | 0.823 | 0.822 | 0.822 | 0.820 | 0.819 | 0.818 | 0.817 | 0.816 | 0.815 | 0.813 | 0.812 |
| 8.0                           | 0.816 | 0.830 | 0.829 | 0.828 | 0.826 | 0.825 | 0.824 | 0.823 | 0.821 | 0.820 | 0.819 | 0.817 | 0.814 | 0.812 |
| 8.5                           | 0.799 | 0.831 | 0.829 | 0.827 | 0.825 | 0.823 | 0.820 | 0.816 | 0.813 | 0.810 | 0.806 | 0.803 | 0.795 | 0.791 |
| 9.0                           | 0.746 | 0.807 | 0.802 | 0.798 | 0.793 | 0.788 | 0.782 | 0.776 | 0.771 | 0.765 | 0.758 | 0.752 | 0.739 | 0.733 |
| 9.5                           | 0.675 | 0.753 | 0.746 | 0.739 | 0.732 | 0.725 | 0.718 | 0.711 | 0.703 | 0.696 | 0.689 | 0.682 | 0.668 | 0.661 |
| 10.0                          | 0.607 | 0.688 | 0.680 | 0.672 | 0.665 | 0.657 | 0.650 | 0.643 | 0.635 | 0.628 | 0.621 | 0.614 | 0.601 | 0.594 |
| 10.5                          | 0.546 | 0.626 | 0.618 | 0.611 | 0.604 | 0.597 | 0.589 | 0.582 | 0.575 | 0.568 | 0.561 | 0.554 | 0.539 | 0.531 |
| 11.0                          | 0.484 | 0.570 | 0.563 | 0.555 | 0.548 | 0.540 | 0.532 | 0.524 | 0.517 | 0.509 | 0.501 | 0.493 | 0.476 | 0.468 |
| 11.5                          | 0.425 | 0.520 | 0.511 | 0.503 | 0.495 | 0.487 | 0.478 | 0.469 | 0.460 | 0.452 | 0.443 | 0.434 | 0.416 | 0.407 |
| 12.0                          | 0.369 | 0.471 | 0.461 | 0.452 | 0.443 | 0.433 | 0.424 | 0.414 | 0.405 | 0.395 | 0.386 | 0.378 | 0.361 | 0.352 |
| 12.5                          | 0.320 | 0.421 | 0.411 | 0.401 | 0.391 | 0.381 | 0.372 | 0.363 | 0.353 | 0.344 | 0.336 | 0.328 | 0.313 | 0.306 |
| 13.0                          | 0.281 | 0.373 | 0.363 | 0.353 | 0.344 | 0.334 | 0.326 | 0.317 | 0.309 | 0.301 | 0.294 | 0.287 | 0.275 | 0.269 |
| 13.5                          | 0.249 | 0.330 | 0.321 | 0.312 | 0.304 | 0.295 | 0.288 | 0.281 | 0.274 | 0.267 | 0.261 | 0.255 | 0.244 | 0.239 |
| 14.0                          | 0.221 | 0.292 | 0.284 | 0.277 | 0.269 | 0.261 | 0.255 | 0.249 | 0.243 | 0.237 | 0.232 | 0.227 | 0.217 | 0.212 |
| 14.5                          | 0.198 | 0.260 | 0.253 | 0.246 | 0.240 | 0.233 | 0.228 | 0.222 | 0.217 | 0.212 | 0.207 | 0.203 | 0.194 | 0.190 |
| 15.0                          | 0.178 | 0.231 | 0.226 | 0.220 | 0.214 | 0.208 | 0.203 | 0.199 | 0.194 | 0.189 | 0.185 | 0.181 | 0.174 | 0.171 |
| 15.5                          | 0.161 | 0.208 | 0.203 | 0.198 | 0.193 | 0.188 | 0.183 | 0.179 | 0.175 | 0.171 | 0.167 | 0.164 | 0.157 | 0.154 |
| 16.0                          | 0.146 | 0.188 | 0.184 | 0.179 | 0.175 | 0.170 | 0.166 | 0.163 | 0.159 | 0.155 | 0.152 | 0.149 | 0.143 | 0.140 |
| 16.5                          | 0.133 | 0.171 | 0.167 | 0.163 | 0.159 | 0.155 | 0.151 | 0.148 | 0.145 | 0.141 | 0.139 | 0.136 | 0.130 | 0.128 |
| 17.0                          | 0.122 | 0.156 | 0.153 | 0.149 | 0.145 | 0.141 | 0.138 | 0.135 | 0.132 | 0.129 | 0.127 | 0.124 | 0.119 | 0.117 |
| 17.5                          | 0.112 | 0.143 | 0.140 | 0.136 | 0.133 | 0.129 | 0.127 | 0.124 | 0.121 | 0.119 | 0.116 | 0.114 | 0.110 | 0.108 |
| 18.0                          | 0.103 | 0.131 | 0.128 | 0.125 | 0.122 | 0.119 | 0.117 | 0.114 | 0.112 | 0.109 | 0.107 | 0.105 | 0.101 | 0.099 |
| 18.5                          | 0.095 | 0.121 | 0.118 | 0.115 | 0.113 | 0.110 | 0.108 | 0.105 | 0.103 | 0.101 | 0.099 | 0.097 | 0.093 | 0.092 |
| 19.0                          | 0.088 | 0.111 | 0.109 | 0.106 | 0.104 | 0.101 | 0.099 | 0.097 | 0.095 | 0.093 | 0.091 | 0.089 | 0.086 | 0.085 |
| 19.5                          | 0.081 | 0.103 | 0.101 | 0.098 | 0.096 | 0.094 | 0.092 | 0.090 | 0.088 | 0.086 | 0.085 | 0.083 | 0.080 | 0.079 |
| 20.0                          | 0.076 | 0.096 | 0.094 | 0.091 | 0.089 | 0.087 | 0.085 | 0.084 | 0.082 | 0.080 | 0.079 | 0.077 | 0.075 | 0.073 |
| 20.5                          | 0.071 | 0.089 | 0.087 | 0.085 | 0.083 | 0.081 | 0.080 | 0.078 | 0.076 | 0.075 | 0.073 | 0.072 | 0.070 | 0.068 |
| 21.0                          | 0.066 | 0.083 | 0.081 | 0.080 | 0.078 | 0.076 | 0.074 | 0.073 | 0.071 | 0.070 | 0.069 | 0.067 | 0.065 | 0.064 |
| 21.5                          | 0.063 | 0.078 | 0.077 | 0.075 | 0.073 | 0.072 | 0.070 | 0.069 | 0.068 | 0.066 | 0.065 | 0.064 | 0.062 | 0.061 |
| 22.0                          | 0.059 | 0.074 | 0.072 | 0.070 | 0.069 | 0.067 | 0.066 | 0.065 | 0.063 | 0.062 | 0.061 | 0.060 | 0.058 | 0.057 |
| 22.5                          | 0.055 | 0.069 | 0.068 | 0.066 | 0.065 | 0.063 | 0.062 | 0.061 | 0.060 | 0.058 | 0.057 | 0.056 | 0.055 | 0.054 |
| 23.0                          | 0.052 | 0.065 | 0.063 | 0.062 | 0.061 | 0.059 | 0.058 | 0.057 | 0.056 | 0.055 | 0.054 | 0.053 | 0.051 | 0.050 |
| 23.5                          | 0.049 | 0.061 | 0.060 | 0.058 | 0.057 | 0.056 | 0.055 | 0.054 | 0.053 | 0.052 | 0.051 | 0.050 | 0.048 | 0.048 |
| 24.0                          | 0.047 | 0.057 | 0.056 | 0.055 | 0.054 | 0.053 | 0.052 | 0.051 | 0.050 | 0.049 | 0.048 | 0.047 | 0.046 | 0.045 |
| 24.5                          | 0.044 | 0.054 | 0.053 | 0.052 | 0.051 | 0.050 | 0.049 | 0.048 | 0.047 | 0.046 | 0.046 | 0.045 | 0.043 | 0.043 |
| 25.0                          | 0.042 | 0.051 | 0.050 | 0.049 | 0.048 | 0.047 | 0.046 | 0.046 | 0.045 | 0.044 | 0.043 | 0.043 | 0.041 | 0.041 |
| 25.5                          | 0.040 | 0.049 | 0.048 | 0.047 | 0.046 | 0.045 | 0.044 | 0.044 | 0.043 | 0.042 | 0.041 | 0.041 | 0.039 | 0.039 |
| 26.0                          | 0.038 | 0.047 | 0.046 | 0.045 | 0.044 | 0.043 | 0.042 | 0.041 | 0.041 | 0.040 | 0.039 | 0.039 | 0.038 | 0.037 |
| 26.5                          | 0.036 | 0.044 | 0.043 | 0.043 | 0.042 | 0.041 | 0.040 | 0.039 | 0.039 | 0.038 | 0.037 | 0.037 | 0.036 | 0.035 |
| 27.0                          | 0.035 | 0.042 | 0.041 | 0.041 | 0.040 | 0.039 | 0.038 | 0.038 | 0.037 | 0.036 | 0.036 | 0.035 | 0.034 | 0.034 |

Table 8-2: C<sub>t</sub> values, Power Optimized Mode PO1/PO1-0S



**8.3 Sound Curves, Power Optimized Mode PO1/PO1-0S**

| Sound Power Level at Hub Height   |  |   |
|-----------------------------------|--|---|
| Conditions for Sound Power Level: | Measurement standard IEC 61400-11 ed. 3<br>Maximum turbulence at hub height: 30%<br>Inflow angle (vertical): 0 ±2°<br>Air density: 1.225 kg/m <sup>3</sup> |   |
| Wind speed at hub height [m/s]    | Sound Power Level at Hub Height [dBA]<br>Power Optimized Mode PO1<br>(Blades with serrated trailing edge)  | Sound Power Level at Hub Height [dBA]<br>Power Optimized Mode PO1-0S<br>(Blades without serrated trailing edge) |
| 3                                 | 90.9   | 93.1  |
| 4                                 | 91.1   | 93.6  |
| 5                                 | 92.8   | 96.4  |
| 6                                 | 95.9   | 99.9  |
| 7                                 | 99.5   | 103.1   |
| 8                                 | 102.8  | 105.9   |
| 9                                 | 103.9  | 106.9   |
| 10                                | 103.9  | 106.9   |
| 11                                | 103.9  | 106.9   |
| 12                                | 103.9  | 106.9   |
| 13                                | 103.9  | 106.9   |
| 14                                | 103.9  | 106.9   |
| 15                                | 103.9  | 106.9   |
| 16                                | 103.9  | 106.9   |
| 17                                | 103.9  | 106.9   |
| 18                                | 103.9  | 106.9   |
| 19                                | 103.9  | 106.9   |
| 20                                | 103.9  | 106.9   |

Table 8-3: Sound curves, Power Optimized Mode PO1/PO1-0S

## 9 Power Curves, Ct Values and Sound Curves, Power Optimized Mode PO1/PO1-0S (HWO)

**NOTE** The power curves and Ct values presented in Section 9 are only valid for low hub heights, i.e. hub heights ≤ 104 m.

### 9.1 Power Curves, Power Optimized Mode PO1/PO1-0S (HWO)

| Wind speed [m/s] | Air density [kg/m <sup>3</sup> ] |       |       |       |       |       |       |       |       |       |       |       |       |       |
|------------------|----------------------------------|-------|-------|-------|-------|-------|-------|-------|-------|-------|-------|-------|-------|-------|
|                  | 1.225                            | 0.950 | 0.975 | 1.000 | 1.025 | 1.050 | 1.075 | 1.100 | 1.125 | 1.150 | 1.175 | 1.200 | 1.250 | 1.275 |
| 3.0              | 55                               | 31    | 33    | 35    | 38    | 40    | 42    | 44    | 46    | 48    | 51    | 53    | 57    | 59    |
| 3.5              | 130                              | 89    | 93    | 97    | 100   | 104   | 108   | 111   | 115   | 119   | 122   | 126   | 133   | 137   |
| 4.0              | 220                              | 159   | 165   | 170   | 176   | 182   | 187   | 193   | 198   | 204   | 209   | 215   | 226   | 231   |
| 4.5              | 331                              | 245   | 253   | 260   | 268   | 276   | 284   | 292   | 299   | 307   | 315   | 323   | 338   | 346   |
| 5.0              | 471                              | 353   | 364   | 374   | 385   | 396   | 407   | 417   | 428   | 439   | 449   | 460   | 481   | 492   |
| 5.5              | 639                              | 483   | 497   | 512   | 526   | 540   | 554   | 568   | 582   | 596   | 610   | 624   | 653   | 667   |
| 6.0              | 841                              | 640   | 659   | 677   | 695   | 714   | 732   | 750   | 768   | 787   | 805   | 823   | 860   | 878   |
| 6.5              | 1080                             | 826   | 849   | 872   | 895   | 919   | 942   | 965   | 988   | 1011  | 1034  | 1057  | 1104  | 1127  |
| 7.0              | 1362                             | 1044  | 1073  | 1102  | 1131  | 1160  | 1189  | 1218  | 1247  | 1276  | 1304  | 1333  | 1390  | 1419  |
| 7.5              | 1681                             | 1293  | 1329  | 1364  | 1399  | 1435  | 1470  | 1505  | 1541  | 1576  | 1611  | 1646  | 1715  | 1750  |
| 8.0              | 2042                             | 1578  | 1620  | 1663  | 1706  | 1748  | 1790  | 1833  | 1875  | 1917  | 1959  | 2000  | 2083  | 2124  |
| 8.5              | 2441                             | 1897  | 1947  | 1998  | 2048  | 2099  | 2148  | 2198  | 2247  | 2297  | 2345  | 2393  | 2488  | 2535  |
| 9.0              | 2845                             | 2242  | 2300  | 2358  | 2415  | 2473  | 2527  | 2582  | 2636  | 2691  | 2742  | 2794  | 2894  | 2943  |
| 9.5              | 3214                             | 2591  | 2652  | 2713  | 2774  | 2836  | 2891  | 2947  | 3003  | 3059  | 3111  | 3162  | 3262  | 3311  |
| 10.0             | 3547                             | 2923  | 2985  | 3047  | 3110  | 3172  | 3228  | 3284  | 3340  | 3396  | 3446  | 3497  | 3593  | 3640  |
| 10.5             | 3832                             | 3227  | 3290  | 3353  | 3416  | 3479  | 3533  | 3587  | 3641  | 3696  | 3741  | 3787  | 3869  | 3906  |
| 11.0             | 4025                             | 3504  | 3563  | 3623  | 3682  | 3742  | 3788  | 3833  | 3879  | 3924  | 3958  | 3991  | 4051  | 4077  |
| 11.5             | 4143                             | 3748  | 3799  | 3851  | 3902  | 3954  | 3987  | 4020  | 4054  | 4087  | 4106  | 4124  | 4155  | 4166  |
| 12.0             | 4188                             | 3942  | 3981  | 4019  | 4057  | 4096  | 4113  | 4131  | 4149  | 4166  | 4174  | 4181  | 4191  | 4194  |
| 12.5             | 4198                             | 4074  | 4097  | 4119  | 4142  | 4164  | 4171  | 4179  | 4186  | 4193  | 4195  | 4197  | 4199  | 4199  |
| 13.0             | 4200                             | 4144  | 4156  | 4167  | 4178  | 4190  | 4192  | 4194  | 4196  | 4199  | 4199  | 4200  | 4200  | 4200  |
| 13.5             | 4200                             | 4165  | 4172  | 4179  | 4186  | 4193  | 4194  | 4196  | 4198  | 4199  | 4199  | 4200  | 4200  | 4200  |
| 14.0             | 4200                             | 4183  | 4187  | 4190  | 4194  | 4198  | 4198  | 4199  | 4199  | 4200  | 4200  | 4200  | 4200  | 4200  |
| 14.5             | 4200                             | 4193  | 4194  | 4196  | 4197  | 4199  | 4199  | 4199  | 4200  | 4200  | 4200  | 4200  | 4200  | 4200  |
| 15.0             | 4200                             | 4194  | 4195  | 4196  | 4197  | 4198  | 4199  | 4199  | 4200  | 4200  | 4200  | 4200  | 4200  | 4200  |
| 15.5             | 4200                             | 4196  | 4197  | 4198  | 4198  | 4199  | 4199  | 4200  | 4200  | 4200  | 4200  | 4200  | 4200  | 4200  |
| 16.0             | 4200                             | 4198  | 4198  | 4199  | 4199  | 4200  | 4200  | 4200  | 4200  | 4200  | 4200  | 4200  | 4200  | 4200  |
| 16.5             | 4200                             | 4198  | 4199  | 4199  | 4200  | 4200  | 4200  | 4200  | 4200  | 4200  | 4200  | 4200  | 4200  | 4200  |
| 17.0             | 4200                             | 4199  | 4199  | 4199  | 4200  | 4200  | 4200  | 4200  | 4200  | 4200  | 4200  | 4200  | 4200  | 4200  |
| 17.5             | 4200                             | 4200  | 4200  | 4200  | 4200  | 4200  | 4200  | 4200  | 4200  | 4200  | 4200  | 4200  | 4200  | 4200  |
| 18.0             | 4200                             | 4200  | 4200  | 4200  | 4200  | 4200  | 4200  | 4200  | 4200  | 4200  | 4200  | 4200  | 4200  | 4200  |
| 18.5             | 4200                             | 4200  | 4200  | 4200  | 4200  | 4200  | 4200  | 4200  | 4200  | 4200  | 4200  | 4200  | 4200  | 4200  |
| 19.0             | 4200                             | 4200  | 4200  | 4200  | 4200  | 4200  | 4200  | 4200  | 4200  | 4200  | 4200  | 4200  | 4200  | 4200  |
| 19.5             | 4200                             | 4200  | 4200  | 4200  | 4200  | 4200  | 4200  | 4200  | 4200  | 4200  | 4200  | 4200  | 4200  | 4200  |
| 20.0             | 4200                             | 4200  | 4200  | 4200  | 4200  | 4200  | 4200  | 4200  | 4200  | 4200  | 4200  | 4200  | 4200  | 4200  |
| 20.5             | 4200                             | 4200  | 4200  | 4200  | 4200  | 4200  | 4200  | 4200  | 4200  | 4200  | 4200  | 4200  | 4200  | 4200  |
| 21.0             | 4200                             | 4200  | 4200  | 4200  | 4200  | 4200  | 4200  | 4200  | 4200  | 4200  | 4200  | 4200  | 4200  | 4200  |
| 21.5             | 4200                             | 4200  | 4200  | 4200  | 4200  | 4200  | 4200  | 4200  | 4200  | 4200  | 4200  | 4200  | 4200  | 4200  |
| 22.0             | 4200                             | 4200  | 4200  | 4200  | 4200  | 4200  | 4200  | 4200  | 4200  | 4200  | 4200  | 4200  | 4200  | 4200  |
| 22.5             | 4200                             | 4200  | 4200  | 4200  | 4200  | 4200  | 4200  | 4200  | 4200  | 4200  | 4200  | 4200  | 4200  | 4200  |
| 23.0             | 4200                             | 4200  | 4200  | 4200  | 4200  | 4200  | 4200  | 4200  | 4200  | 4200  | 4200  | 4200  | 4200  | 4200  |
| 23.5             | 4200                             | 4200  | 4200  | 4200  | 4200  | 4200  | 4200  | 4200  | 4200  | 4200  | 4200  | 4200  | 4200  | 4200  |
| 24.0             | 4199                             | 4199  | 4199  | 4199  | 4199  | 4199  | 4199  | 4199  | 4199  | 4199  | 4199  | 4199  | 4199  | 4199  |
| 24.5             | 4189                             | 4189  | 4189  | 4189  | 4189  | 4189  | 4189  | 4189  | 4189  | 4189  | 4189  | 4189  | 4189  | 4189  |
| 25.0             | 4147                             | 4147  | 4147  | 4147  | 4147  | 4146  | 4146  | 4146  | 4146  | 4146  | 4147  | 4147  | 4147  | 4147  |
| 25.5             | 4079                             | 4079  | 4079  | 4079  | 4079  | 4079  | 4079  | 4079  | 4079  | 4079  | 4079  | 4079  | 4079  | 4079  |
| 26.0             | 3984                             | 3984  | 3984  | 3984  | 3984  | 3984  | 3984  | 3984  | 3984  | 3984  | 3984  | 3984  | 3984  | 3984  |
| 26.5             | 3873                             | 3873  | 3873  | 3873  | 3873  | 3873  | 3873  | 3873  | 3873  | 3873  | 3873  | 3873  | 3873  | 3873  |
| 27.0             | 3763                             | 3763  | 3763  | 3763  | 3763  | 3763  | 3763  | 3763  | 3763  | 3763  | 3763  | 3763  | 3763  | 3763  |
| 27.5             | 3629                             | 3629  | 3629  | 3629  | 3629  | 3629  | 3629  | 3629  | 3629  | 3629  | 3629  | 3629  | 3629  | 3629  |



| <b>Air density [kg/m<sup>3</sup>]</b> |              |              |              |              |              |              |              |              |              |              |              |              |              |              |
|---------------------------------------|--------------|--------------|--------------|--------------|--------------|--------------|--------------|--------------|--------------|--------------|--------------|--------------|--------------|--------------|
| <b>Wind speed [m/s]</b>               | <b>1.225</b> | <b>0.950</b> | <b>0.975</b> | <b>1.000</b> | <b>1.025</b> | <b>1.050</b> | <b>1.075</b> | <b>1.100</b> | <b>1.125</b> | <b>1.150</b> | <b>1.175</b> | <b>1.200</b> | <b>1.250</b> | <b>1.275</b> |
| <b>28.0</b>                           | <b>3467</b>  | 3467         | 3467         | 3467         | 3467         | 3467         | 3467         | 3467         | 3467         | 3467         | 3467         | 3467         | 3467         | 3467         |
| <b>28.5</b>                           | <b>3274</b>  | 3274         | 3274         | 3274         | 3274         | 3274         | 3274         | 3274         | 3274         | 3274         | 3274         | 3274         | 3274         | 3274         |
| <b>29.0</b>                           | <b>3048</b>  | 3048         | 3048         | 3048         | 3048         | 3048         | 3048         | 3048         | 3048         | 3048         | 3048         | 3048         | 3048         | 3048         |
| <b>29.5</b>                           | <b>2805</b>  | 2805         | 2805         | 2805         | 2805         | 2805         | 2805         | 2805         | 2805         | 2805         | 2805         | 2805         | 2805         | 2805         |
| <b>30.0</b>                           | <b>2564</b>  | 2564         | 2564         | 2564         | 2564         | 2564         | 2564         | 2564         | 2564         | 2564         | 2564         | 2564         | 2564         | 2564         |
| <b>30.5</b>                           | <b>2324</b>  | 2324         | 2324         | 2324         | 2324         | 2324         | 2324         | 2324         | 2324         | 2324         | 2324         | 2324         | 2324         | 2324         |
| <b>31.0</b>                           | <b>2089</b>  | 2089         | 2089         | 2089         | 2089         | 2089         | 2089         | 2089         | 2089         | 2089         | 2089         | 2089         | 2089         | 2089         |
| <b>31.5</b>                           | <b>1883</b>  | 1884         | 1884         | 1884         | 1884         | 1884         | 1883         | 1883         | 1883         | 1883         | 1883         | 1883         | 1883         | 1883         |
| <b>32.0</b>                           | <b>1732</b>  | 1732         | 1731         | 1731         | 1731         | 1731         | 1731         | 1731         | 1731         | 1732         | 1732         | 1732         | 1732         | 1732         |

*Table 9-1: Power curve, Power Optimized Mode PO1/PO1-0S (HWO)*

**9.2 Ct Values, Power Optimized Mode PO1/PO1-0S (HWO)**

| Air density kg/m <sup>3</sup> |       |       |       |       |       |       |       |       |       |       |       |       |       |       |
|-------------------------------|-------|-------|-------|-------|-------|-------|-------|-------|-------|-------|-------|-------|-------|-------|
| Wind speed [m/s]              | 1.225 | 0.950 | 0.975 | 1.000 | 1.025 | 1.050 | 1.075 | 1.100 | 1.125 | 1.150 | 1.175 | 1.200 | 1.250 | 1.275 |
| 3.0                           | 0.873 | 0.878 | 0.877 | 0.877 | 0.876 | 0.876 | 0.876 | 0.875 | 0.875 | 0.874 | 0.874 | 0.874 | 0.873 | 0.873 |
| 3.5                           | 0.847 | 0.851 | 0.851 | 0.850 | 0.850 | 0.850 | 0.849 | 0.849 | 0.849 | 0.848 | 0.848 | 0.848 | 0.847 | 0.846 |
| 4.0                           | 0.845 | 0.854 | 0.853 | 0.851 | 0.850 | 0.848 | 0.848 | 0.848 | 0.847 | 0.847 | 0.847 | 0.846 | 0.845 | 0.845 |
| 4.5                           | 0.843 | 0.842 | 0.842 | 0.843 | 0.843 | 0.843 | 0.843 | 0.843 | 0.843 | 0.844 | 0.843 | 0.843 | 0.843 | 0.843 |
| 5.0                           | 0.844 | 0.848 | 0.848 | 0.848 | 0.847 | 0.847 | 0.847 | 0.846 | 0.846 | 0.845 | 0.845 | 0.845 | 0.844 | 0.843 |
| 5.5                           | 0.840 | 0.845 | 0.845 | 0.844 | 0.844 | 0.843 | 0.843 | 0.842 | 0.842 | 0.841 | 0.841 | 0.840 | 0.839 | 0.839 |
| 6.0                           | 0.834 | 0.840 | 0.840 | 0.839 | 0.839 | 0.838 | 0.838 | 0.837 | 0.837 | 0.836 | 0.835 | 0.835 | 0.834 | 0.833 |
| 6.5                           | 0.828 | 0.836 | 0.835 | 0.835 | 0.834 | 0.833 | 0.833 | 0.832 | 0.831 | 0.831 | 0.830 | 0.829 | 0.827 | 0.826 |
| 7.0                           | 0.821 | 0.831 | 0.830 | 0.829 | 0.828 | 0.828 | 0.827 | 0.826 | 0.825 | 0.824 | 0.823 | 0.822 | 0.820 | 0.819 |
| 7.5                           | 0.814 | 0.825 | 0.824 | 0.823 | 0.822 | 0.822 | 0.820 | 0.819 | 0.818 | 0.817 | 0.816 | 0.815 | 0.813 | 0.812 |
| 8.0                           | 0.816 | 0.830 | 0.829 | 0.828 | 0.826 | 0.825 | 0.824 | 0.823 | 0.821 | 0.820 | 0.819 | 0.817 | 0.814 | 0.812 |
| 8.5                           | 0.799 | 0.831 | 0.829 | 0.827 | 0.825 | 0.823 | 0.820 | 0.816 | 0.813 | 0.810 | 0.806 | 0.803 | 0.795 | 0.791 |
| 9.0                           | 0.746 | 0.807 | 0.802 | 0.798 | 0.793 | 0.788 | 0.782 | 0.776 | 0.771 | 0.765 | 0.758 | 0.752 | 0.739 | 0.733 |
| 9.5                           | 0.675 | 0.753 | 0.746 | 0.739 | 0.732 | 0.725 | 0.718 | 0.711 | 0.703 | 0.696 | 0.689 | 0.682 | 0.668 | 0.661 |
| 10.0                          | 0.607 | 0.688 | 0.680 | 0.672 | 0.665 | 0.657 | 0.650 | 0.643 | 0.635 | 0.628 | 0.621 | 0.614 | 0.601 | 0.594 |
| 10.5                          | 0.546 | 0.626 | 0.618 | 0.611 | 0.604 | 0.597 | 0.589 | 0.582 | 0.575 | 0.568 | 0.561 | 0.554 | 0.539 | 0.531 |
| 11.0                          | 0.484 | 0.570 | 0.563 | 0.555 | 0.548 | 0.540 | 0.532 | 0.524 | 0.517 | 0.509 | 0.501 | 0.493 | 0.476 | 0.468 |
| 11.5                          | 0.425 | 0.520 | 0.511 | 0.503 | 0.495 | 0.487 | 0.478 | 0.469 | 0.460 | 0.452 | 0.443 | 0.434 | 0.416 | 0.407 |
| 12.0                          | 0.369 | 0.471 | 0.461 | 0.452 | 0.443 | 0.433 | 0.424 | 0.414 | 0.405 | 0.395 | 0.386 | 0.378 | 0.361 | 0.352 |
| 12.5                          | 0.320 | 0.421 | 0.411 | 0.401 | 0.391 | 0.381 | 0.372 | 0.363 | 0.353 | 0.344 | 0.336 | 0.328 | 0.313 | 0.306 |
| 13.0                          | 0.281 | 0.373 | 0.363 | 0.353 | 0.344 | 0.334 | 0.326 | 0.317 | 0.309 | 0.301 | 0.294 | 0.287 | 0.275 | 0.269 |
| 13.5                          | 0.249 | 0.330 | 0.321 | 0.312 | 0.304 | 0.295 | 0.288 | 0.281 | 0.274 | 0.267 | 0.261 | 0.255 | 0.244 | 0.239 |
| 14.0                          | 0.221 | 0.292 | 0.284 | 0.277 | 0.269 | 0.261 | 0.255 | 0.249 | 0.243 | 0.237 | 0.232 | 0.227 | 0.217 | 0.212 |
| 14.5                          | 0.198 | 0.260 | 0.253 | 0.246 | 0.240 | 0.233 | 0.228 | 0.222 | 0.217 | 0.212 | 0.207 | 0.203 | 0.194 | 0.190 |
| 15.0                          | 0.178 | 0.231 | 0.226 | 0.220 | 0.214 | 0.208 | 0.203 | 0.199 | 0.194 | 0.189 | 0.185 | 0.181 | 0.174 | 0.171 |
| 15.5                          | 0.161 | 0.208 | 0.203 | 0.198 | 0.193 | 0.188 | 0.183 | 0.179 | 0.175 | 0.171 | 0.167 | 0.164 | 0.157 | 0.154 |
| 16.0                          | 0.146 | 0.188 | 0.184 | 0.179 | 0.175 | 0.170 | 0.166 | 0.163 | 0.159 | 0.155 | 0.152 | 0.149 | 0.143 | 0.140 |
| 16.5                          | 0.133 | 0.171 | 0.167 | 0.163 | 0.159 | 0.155 | 0.151 | 0.148 | 0.145 | 0.141 | 0.139 | 0.136 | 0.130 | 0.128 |
| 17.0                          | 0.122 | 0.156 | 0.153 | 0.149 | 0.145 | 0.141 | 0.138 | 0.135 | 0.132 | 0.129 | 0.127 | 0.124 | 0.119 | 0.117 |
| 17.5                          | 0.112 | 0.143 | 0.140 | 0.136 | 0.133 | 0.129 | 0.127 | 0.124 | 0.121 | 0.119 | 0.116 | 0.114 | 0.110 | 0.108 |
| 18.0                          | 0.103 | 0.131 | 0.128 | 0.125 | 0.122 | 0.119 | 0.117 | 0.114 | 0.112 | 0.109 | 0.107 | 0.105 | 0.101 | 0.099 |
| 18.5                          | 0.095 | 0.121 | 0.118 | 0.115 | 0.113 | 0.110 | 0.108 | 0.105 | 0.103 | 0.101 | 0.099 | 0.097 | 0.093 | 0.092 |
| 19.0                          | 0.088 | 0.111 | 0.109 | 0.106 | 0.104 | 0.101 | 0.099 | 0.097 | 0.095 | 0.093 | 0.091 | 0.089 | 0.086 | 0.085 |
| 19.5                          | 0.081 | 0.103 | 0.101 | 0.098 | 0.096 | 0.094 | 0.092 | 0.090 | 0.088 | 0.086 | 0.085 | 0.083 | 0.080 | 0.079 |
| 20.0                          | 0.076 | 0.096 | 0.094 | 0.091 | 0.089 | 0.087 | 0.085 | 0.084 | 0.082 | 0.080 | 0.079 | 0.077 | 0.075 | 0.073 |
| 20.5                          | 0.071 | 0.089 | 0.087 | 0.085 | 0.083 | 0.081 | 0.080 | 0.078 | 0.076 | 0.075 | 0.073 | 0.072 | 0.070 | 0.068 |
| 21.0                          | 0.066 | 0.083 | 0.081 | 0.080 | 0.078 | 0.076 | 0.074 | 0.073 | 0.071 | 0.070 | 0.069 | 0.067 | 0.065 | 0.064 |
| 21.5                          | 0.063 | 0.078 | 0.077 | 0.075 | 0.073 | 0.072 | 0.070 | 0.069 | 0.068 | 0.066 | 0.065 | 0.064 | 0.062 | 0.061 |
| 22.0                          | 0.059 | 0.074 | 0.072 | 0.070 | 0.069 | 0.067 | 0.066 | 0.065 | 0.063 | 0.062 | 0.061 | 0.060 | 0.058 | 0.057 |
| 22.5                          | 0.055 | 0.069 | 0.068 | 0.066 | 0.065 | 0.063 | 0.062 | 0.061 | 0.060 | 0.058 | 0.057 | 0.056 | 0.055 | 0.054 |
| 23.0                          | 0.052 | 0.065 | 0.063 | 0.062 | 0.061 | 0.059 | 0.058 | 0.057 | 0.056 | 0.055 | 0.054 | 0.053 | 0.051 | 0.050 |
| 23.5                          | 0.049 | 0.061 | 0.060 | 0.058 | 0.057 | 0.056 | 0.055 | 0.054 | 0.053 | 0.052 | 0.051 | 0.050 | 0.048 | 0.048 |
| 24.0                          | 0.046 | 0.057 | 0.056 | 0.055 | 0.054 | 0.053 | 0.052 | 0.051 | 0.050 | 0.049 | 0.048 | 0.047 | 0.046 | 0.045 |
| 24.5                          | 0.044 | 0.054 | 0.053 | 0.052 | 0.051 | 0.050 | 0.049 | 0.048 | 0.047 | 0.046 | 0.045 | 0.045 | 0.043 | 0.043 |
| 25.0                          | 0.041 | 0.051 | 0.050 | 0.049 | 0.048 | 0.047 | 0.046 | 0.045 | 0.044 | 0.043 | 0.043 | 0.042 | 0.041 | 0.040 |
| 25.5                          | 0.039 | 0.048 | 0.047 | 0.046 | 0.045 | 0.044 | 0.043 | 0.042 | 0.042 | 0.041 | 0.040 | 0.040 | 0.038 | 0.038 |
| 26.0                          | 0.036 | 0.044 | 0.043 | 0.043 | 0.042 | 0.041 | 0.040 | 0.039 | 0.039 | 0.038 | 0.037 | 0.037 | 0.036 | 0.035 |
| 26.5                          | 0.034 | 0.041 | 0.040 | 0.039 | 0.039 | 0.038 | 0.037 | 0.037 | 0.036 | 0.035 | 0.035 | 0.034 | 0.033 | 0.033 |
| 27.0                          | 0.031 | 0.038 | 0.037 | 0.036 | 0.036 | 0.035 | 0.034 | 0.034 | 0.033 | 0.033 | 0.032 | 0.032 | 0.031 | 0.030 |
| 27.5                          | 0.029 | 0.035 | 0.034 | 0.034 | 0.033 | 0.032 | 0.032 | 0.031 | 0.031 | 0.030 | 0.030 | 0.029 | 0.028 | 0.028 |
| 28.0                          | 0.026 | 0.032 | 0.031 | 0.031 | 0.030 | 0.029 | 0.029 | 0.028 | 0.028 | 0.028 | 0.027 | 0.027 | 0.026 | 0.025 |
| 28.5                          | 0.024 | 0.029 | 0.028 | 0.028 | 0.027 | 0.027 | 0.026 | 0.026 | 0.025 | 0.025 | 0.025 | 0.024 | 0.023 | 0.023 |
| 29.0                          | 0.021 | 0.026 | 0.025 | 0.025 | 0.024 | 0.024 | 0.024 | 0.023 | 0.023 | 0.022 | 0.022 | 0.022 | 0.021 | 0.021 |
| 29.5                          | 0.019 | 0.023 | 0.023 | 0.022 | 0.022 | 0.021 | 0.021 | 0.021 | 0.020 | 0.020 | 0.020 | 0.019 | 0.019 | 0.019 |
| 30.0                          | 0.017 | 0.020 | 0.020 | 0.020 | 0.019 | 0.019 | 0.018 | 0.018 | 0.018 | 0.018 | 0.017 | 0.017 | 0.017 | 0.016 |
| 30.5                          | 0.015 | 0.018 | 0.017 | 0.017 | 0.017 | 0.016 | 0.016 | 0.016 | 0.016 | 0.015 | 0.015 | 0.015 | 0.015 | 0.014 |
| 31.0                          | 0.013 | 0.015 | 0.015 | 0.015 | 0.015 | 0.014 | 0.014 | 0.014 | 0.014 | 0.013 | 0.013 | 0.013 | 0.013 | 0.013 |
| 31.5                          | 0.011 | 0.014 | 0.013 | 0.013 | 0.013 | 0.013 | 0.012 | 0.012 | 0.012 | 0.012 | 0.012 | 0.012 | 0.011 | 0.011 |
| 32.0                          | 0.010 | 0.012 | 0.012 | 0.012 | 0.012 | 0.011 | 0.011 | 0.011 | 0.011 | 0.011 | 0.011 | 0.010 | 0.010 | 0.010 |

Table 9-2: C<sub>t</sub> values, Power Optimized Mode PO1/PO1-0S (HWO)

**9.3 Sound Curves, Power Optimized Mode PO1/PO1-0S (HWO)**

| Sound Power Level at Hub Height   |  |  |
|-----------------------------------|--|--|
| Conditions for Sound Power Level: | Measurement standard IEC 61400-11 ed. 3<br>Maximum turbulence at hub height: 30%<br>Inflow angle (vertical): 0 ±2°<br>Air density: 1.225 kg/m <sup>3</sup> |  |
| Wind speed at hub height [m/s]    | Sound Power Level at Hub Height [dBA]<br>Power Optimized Mode PO1 (HWO) (Blades with serrated trailing edge)   | Sound Power Level at Hub Height [dBA]<br>Power Optimized Mode PO1-0S (HWO) (Blades without serrated trailing edge) |
| 3                                 | 90.9   | 93.1   |
| 4                                 | 91.1   | 93.6   |
| 5                                 | 92.8   | 96.4   |
| 6                                 | 95.9   | 99.9   |
| 7                                 | 99.5   | 103.1  |
| 8                                 | 102.8  | 105.9  |
| 9                                 | 103.9  | 106.9  |
| 10                                | 103.9  | 106.9  |
| 11                                | 103.9  | 106.9  |
| 12                                | 103.9  | 106.9  |
| 13                                | 103.9  | 106.9  |
| 14                                | 103.9  | 106.9  |
| 15                                | 103.9  | 106.9  |
| 16                                | 103.9  | 106.9  |
| 17                                | 103.9  | 106.9  |
| 18                                | 103.9  | 106.9  |
| 19                                | 103.9  | 106.9  |
| 20                                | 103.9  | 106.9  |

Table 9-3: Sound curves, Power Optimized Mode PO1/PO1-0S (HWO)

**10 Power Curves, Ct Values and Sound Curves, Sound Optimized Mode SO1**

**NOTE** The power curves and Ct values presented in Section 10 are only valid for low hub heights, i.e. hub heights ≤ 104 m.

**10.1 Power Curves, Sound Optimized Mode SO1**

| Air density [kg/m <sup>3</sup> ] |       |       |       |       |       |       |       |       |       |       |       |       |       |       |
|----------------------------------|-------|-------|-------|-------|-------|-------|-------|-------|-------|-------|-------|-------|-------|-------|
| Wind speed [m/s]                 | 1.225 | 0.950 | 0.975 | 1.000 | 1.025 | 1.050 | 1.075 | 1.100 | 1.125 | 1.150 | 1.175 | 1.200 | 1.250 | 1.275 |
| 3.0                              | 55    | 31    | 33    | 35    | 38    | 40    | 42    | 44    | 46    | 48    | 51    | 53    | 57    | 59    |
| 3.5                              | 130   | 89    | 93    | 97    | 100   | 104   | 108   | 111   | 115   | 119   | 122   | 126   | 133   | 137   |
| 4.0                              | 220   | 159   | 165   | 170   | 176   | 182   | 187   | 193   | 198   | 204   | 209   | 215   | 226   | 231   |
| 4.5                              | 331   | 246   | 253   | 261   | 269   | 277   | 284   | 292   | 300   | 308   | 316   | 324   | 339   | 347   |
| 5.0                              | 470   | 352   | 363   | 374   | 385   | 395   | 406   | 417   | 427   | 438   | 449   | 459   | 481   | 491   |
| 5.5                              | 638   | 483   | 497   | 511   | 525   | 539   | 553   | 568   | 582   | 596   | 610   | 624   | 652   | 666   |
| 6.0                              | 840   | 640   | 658   | 676   | 694   | 713   | 731   | 749   | 768   | 786   | 804   | 822   | 859   | 877   |
| 6.5                              | 1079  | 825   | 848   | 871   | 895   | 918   | 941   | 964   | 987   | 1010  | 1033  | 1056  | 1102  | 1125  |
| 7.0                              | 1361  | 1043  | 1072  | 1101  | 1130  | 1159  | 1188  | 1217  | 1246  | 1274  | 1303  | 1332  | 1390  | 1418  |
| 7.5                              | 1681  | 1293  | 1328  | 1364  | 1399  | 1435  | 1470  | 1506  | 1541  | 1576  | 1611  | 1646  | 1716  | 1751  |
| 8.0                              | 2039  | 1574  | 1617  | 1659  | 1702  | 1744  | 1787  | 1829  | 1871  | 1914  | 1955  | 1997  | 2080  | 2122  |
| 8.5                              | 2420  | 1877  | 1927  | 1977  | 2027  | 2077  | 2126  | 2176  | 2225  | 2274  | 2323  | 2372  | 2468  | 2516  |
| 9.0                              | 2793  | 2178  | 2235  | 2292  | 2349  | 2406  | 2462  | 2518  | 2574  | 2630  | 2685  | 2739  | 2845  | 2897  |
| 9.5                              | 3119  | 2458  | 2521  | 2584  | 2647  | 2710  | 2771  | 2831  | 2892  | 2953  | 3008  | 3064  | 3168  | 3218  |
| 10.0                             | 3386  | 2729  | 2796  | 2864  | 2932  | 2999  | 3060  | 3120  | 3181  | 3241  | 3290  | 3338  | 3424  | 3462  |
| 10.5                             | 3585  | 3016  | 3083  | 3151  | 3218  | 3286  | 3336  | 3386  | 3437  | 3487  | 3520  | 3553  | 3608  | 3631  |
| 11.0                             | 3716  | 3278  | 3337  | 3396  | 3456  | 3515  | 3551  | 3587  | 3622  | 3658  | 3677  | 3697  | 3726  | 3736  |
| 11.5                             | 3786  | 3490  | 3537  | 3585  | 3632  | 3679  | 3699  | 3720  | 3740  | 3760  | 3769  | 3777  | 3790  | 3794  |
| 12.0                             | 3821  | 3653  | 3683  | 3712  | 3741  | 3771  | 3781  | 3791  | 3801  | 3811  | 3814  | 3817  | 3822  | 3823  |
| 12.5                             | 3840  | 3758  | 3774  | 3789  | 3805  | 3820  | 3824  | 3829  | 3833  | 3837  | 3838  | 3839  | 3841  | 3842  |
| 13.0                             | 3859  | 3818  | 3826  | 3834  | 3842  | 3850  | 3852  | 3854  | 3856  | 3858  | 3858  | 3859  | 3860  | 3860  |
| 13.5                             | 3881  | 3852  | 3858  | 3863  | 3869  | 3875  | 3876  | 3878  | 3879  | 3880  | 3881  | 3881  | 3881  | 3881  |
| 14.0                             | 3900  | 3886  | 3889  | 3892  | 3895  | 3898  | 3899  | 3899  | 3900  | 3900  | 3900  | 3900  | 3900  | 3900  |
| 14.5                             | 3918  | 3911  | 3912  | 3914  | 3915  | 3917  | 3917  | 3917  | 3918  | 3918  | 3918  | 3918  | 3918  | 3917  |
| 15.0                             | 3932  | 3928  | 3929  | 3930  | 3931  | 3932  | 3932  | 3932  | 3933  | 3933  | 3933  | 3932  | 3932  | 3932  |
| 15.5                             | 3945  | 3943  | 3943  | 3944  | 3945  | 3945  | 3945  | 3946  | 3946  | 3946  | 3946  | 3945  | 3945  | 3945  |
| 16.0                             | 3957  | 3956  | 3957  | 3957  | 3957  | 3958  | 3958  | 3958  | 3957  | 3957  | 3957  | 3957  | 3957  | 3956  |
| 16.5                             | 3969  | 3970  | 3970  | 3970  | 3970  | 3970  | 3970  | 3970  | 3970  | 3970  | 3969  | 3969  | 3969  | 3968  |
| 17.0                             | 3981  | 3982  | 3982  | 3982  | 3983  | 3983  | 3982  | 3982  | 3982  | 3982  | 3982  | 3981  | 3981  | 3981  |
| 17.5                             | 3991  | 3992  | 3992  | 3992  | 3992  | 3992  | 3992  | 3992  | 3992  | 3992  | 3992  | 3992  | 3991  | 3991  |
| 18.0                             | 3997  | 3998  | 3998  | 3998  | 3998  | 3998  | 3998  | 3998  | 3997  | 3997  | 3997  | 3997  | 3997  | 3997  |
| 18.5                             | 3999  | 4000  | 3999  | 3999  | 3999  | 3999  | 3999  | 3999  | 3999  | 3999  | 3999  | 3999  | 3999  | 3999  |
| 19.0                             | 4000  | 4000  | 4000  | 4000  | 4000  | 4000  | 4000  | 4000  | 4000  | 4000  | 4000  | 4000  | 4000  | 4000  |
| 19.5                             | 4000  | 4000  | 4000  | 4000  | 4000  | 4000  | 4000  | 4000  | 4000  | 4000  | 4000  | 4000  | 4000  | 4000  |
| 20.0                             | 4000  | 4000  | 4000  | 4000  | 4000  | 4000  | 4000  | 4000  | 4000  | 4000  | 4000  | 4000  | 4000  | 4000  |
| 20.5                             | 4000  | 4000  | 4000  | 4000  | 4000  | 4000  | 4000  | 4000  | 4000  | 4000  | 4000  | 4000  | 4000  | 4000  |
| 21.0                             | 4000  | 4000  | 4000  | 4000  | 4000  | 4000  | 4000  | 4000  | 4000  | 4000  | 4000  | 4000  | 4000  | 4000  |
| 21.5                             | 4000  | 4000  | 4000  | 4000  | 4000  | 4000  | 4000  | 4000  | 4000  | 4000  | 4000  | 4000  | 4000  | 4000  |
| 22.0                             | 4000  | 4000  | 4000  | 4000  | 4000  | 4000  | 4000  | 4000  | 4000  | 4000  | 4000  | 4000  | 4000  | 4000  |
| 22.5                             | 4000  | 4000  | 4000  | 4000  | 4000  | 4000  | 4000  | 4000  | 4000  | 4000  | 4000  | 4000  | 4000  | 4000  |
| 23.0                             | 4000  | 4000  | 4000  | 4000  | 4000  | 4000  | 4000  | 4000  | 4000  | 4000  | 4000  | 4000  | 4000  | 4000  |
| 23.5                             | 4000  | 4000  | 4000  | 4000  | 4000  | 4000  | 4000  | 4000  | 4000  | 4000  | 4000  | 4000  | 4000  | 4000  |
| 24.0                             | 4000  | 4000  | 4000  | 4000  | 4000  | 4000  | 4000  | 4000  | 4000  | 4000  | 4000  | 4000  | 4000  | 4000  |
| 24.5                             | 4000  | 4000  | 4000  | 4000  | 4000  | 4000  | 4000  | 4000  | 4000  | 4000  | 4000  | 4000  | 4000  | 4000  |
| 25.0                             | 4000  | 4000  | 4000  | 4000  | 4000  | 4000  | 4000  | 4000  | 4000  | 4000  | 4000  | 4000  | 4000  | 4000  |
| 25.5                             | 4000  | 4000  | 4000  | 4000  | 4000  | 4000  | 4000  | 4000  | 4000  | 4000  | 4000  | 4000  | 4000  | 4000  |
| 26.0                             | 4000  | 4000  | 4000  | 4000  | 4000  | 4000  | 4000  | 4000  | 4000  | 4000  | 4000  | 4000  | 4000  | 4000  |
| 26.5                             | 4000  | 4000  | 4000  | 4000  | 4000  | 4000  | 4000  | 4000  | 4000  | 4000  | 4000  | 4000  | 4000  | 4000  |
| 27.0                             | 4000  | 4000  | 4000  | 4000  | 4000  | 4000  | 4000  | 4000  | 4000  | 4000  | 4000  | 4000  | 4000  | 4000  |

Table 10-1: Power curve, Sound Optimized Mode SO1

**10.2 Ct Values, Sound Optimized Mode SO1**

| Air density kg/m <sup>3</sup> |       |       |       |       |       |       |       |       |       |       |       |       |       |       |
|-------------------------------|-------|-------|-------|-------|-------|-------|-------|-------|-------|-------|-------|-------|-------|-------|
| Wind speed [m/s]              | 1.225 | 0.950 | 0.975 | 1.000 | 1.025 | 1.050 | 1.075 | 1.100 | 1.125 | 1.150 | 1.175 | 1.200 | 1.250 | 1.275 |
| 3.0                           | 0.873 | 0.878 | 0.877 | 0.877 | 0.876 | 0.876 | 0.876 | 0.875 | 0.875 | 0.874 | 0.874 | 0.874 | 0.873 | 0.873 |
| 3.5                           | 0.847 | 0.851 | 0.851 | 0.850 | 0.850 | 0.850 | 0.849 | 0.849 | 0.849 | 0.848 | 0.848 | 0.848 | 0.847 | 0.846 |
| 4.0                           | 0.845 | 0.854 | 0.853 | 0.851 | 0.850 | 0.848 | 0.848 | 0.848 | 0.847 | 0.847 | 0.847 | 0.846 | 0.845 | 0.845 |
| 4.5                           | 0.849 | 0.848 | 0.848 | 0.848 | 0.849 | 0.849 | 0.849 | 0.849 | 0.849 | 0.849 | 0.849 | 0.849 | 0.849 | 0.848 |
| 5.0                           | 0.843 | 0.847 | 0.847 | 0.847 | 0.847 | 0.846 | 0.846 | 0.846 | 0.845 | 0.845 | 0.844 | 0.844 | 0.843 | 0.842 |
| 5.5                           | 0.839 | 0.845 | 0.844 | 0.844 | 0.843 | 0.843 | 0.842 | 0.842 | 0.841 | 0.840 | 0.840 | 0.839 | 0.838 | 0.838 |
| 6.0                           | 0.833 | 0.840 | 0.839 | 0.839 | 0.838 | 0.838 | 0.837 | 0.837 | 0.836 | 0.835 | 0.835 | 0.834 | 0.833 | 0.832 |
| 6.5                           | 0.830 | 0.838 | 0.837 | 0.836 | 0.836 | 0.835 | 0.834 | 0.833 | 0.833 | 0.832 | 0.831 | 0.830 | 0.829 | 0.828 |
| 7.0                           | 0.832 | 0.841 | 0.841 | 0.840 | 0.839 | 0.838 | 0.837 | 0.836 | 0.835 | 0.835 | 0.834 | 0.833 | 0.831 | 0.830 |
| 7.5                           | 0.835 | 0.846 | 0.845 | 0.844 | 0.843 | 0.842 | 0.841 | 0.840 | 0.839 | 0.838 | 0.837 | 0.836 | 0.834 | 0.833 |
| 8.0                           | 0.827 | 0.839 | 0.838 | 0.837 | 0.836 | 0.835 | 0.834 | 0.832 | 0.831 | 0.830 | 0.829 | 0.828 | 0.825 | 0.824 |
| 8.5                           | 0.787 | 0.801 | 0.800 | 0.799 | 0.798 | 0.797 | 0.796 | 0.795 | 0.794 | 0.793 | 0.791 | 0.789 | 0.784 | 0.782 |
| 9.0                           | 0.720 | 0.736 | 0.736 | 0.735 | 0.734 | 0.733 | 0.732 | 0.730 | 0.729 | 0.727 | 0.725 | 0.723 | 0.717 | 0.714 |
| 9.5                           | 0.643 | 0.663 | 0.662 | 0.661 | 0.660 | 0.660 | 0.658 | 0.657 | 0.655 | 0.654 | 0.650 | 0.647 | 0.639 | 0.634 |
| 10.0                          | 0.572 | 0.605 | 0.604 | 0.603 | 0.602 | 0.600 | 0.597 | 0.594 | 0.591 | 0.588 | 0.583 | 0.577 | 0.564 | 0.557 |
| 10.5                          | 0.504 | 0.570 | 0.567 | 0.563 | 0.559 | 0.555 | 0.549 | 0.543 | 0.536 | 0.530 | 0.521 | 0.512 | 0.495 | 0.486 |
| 11.0                          | 0.441 | 0.534 | 0.527 | 0.521 | 0.514 | 0.507 | 0.498 | 0.489 | 0.480 | 0.471 | 0.461 | 0.451 | 0.431 | 0.422 |
| 11.5                          | 0.382 | 0.489 | 0.480 | 0.471 | 0.461 | 0.452 | 0.442 | 0.431 | 0.421 | 0.411 | 0.401 | 0.392 | 0.373 | 0.365 |
| 12.0                          | 0.331 | 0.438 | 0.427 | 0.417 | 0.406 | 0.396 | 0.386 | 0.376 | 0.366 | 0.356 | 0.348 | 0.340 | 0.324 | 0.316 |
| 12.5                          | 0.290 | 0.386 | 0.376 | 0.365 | 0.355 | 0.345 | 0.337 | 0.328 | 0.319 | 0.311 | 0.304 | 0.297 | 0.283 | 0.277 |
| 13.0                          | 0.256 | 0.339 | 0.330 | 0.321 | 0.312 | 0.303 | 0.296 | 0.288 | 0.281 | 0.274 | 0.268 | 0.262 | 0.250 | 0.245 |
| 13.5                          | 0.229 | 0.301 | 0.293 | 0.286 | 0.278 | 0.270 | 0.264 | 0.257 | 0.251 | 0.245 | 0.239 | 0.234 | 0.224 | 0.219 |
| 14.0                          | 0.205 | 0.268 | 0.262 | 0.255 | 0.248 | 0.241 | 0.235 | 0.230 | 0.224 | 0.219 | 0.214 | 0.209 | 0.201 | 0.197 |
| 14.5                          | 0.184 | 0.241 | 0.234 | 0.228 | 0.222 | 0.216 | 0.211 | 0.206 | 0.202 | 0.197 | 0.193 | 0.188 | 0.181 | 0.177 |
| 15.0                          | 0.166 | 0.216 | 0.210 | 0.205 | 0.199 | 0.194 | 0.190 | 0.185 | 0.181 | 0.177 | 0.173 | 0.170 | 0.163 | 0.160 |
| 15.5                          | 0.151 | 0.195 | 0.190 | 0.185 | 0.181 | 0.176 | 0.172 | 0.168 | 0.164 | 0.160 | 0.157 | 0.154 | 0.148 | 0.145 |
| 16.0                          | 0.137 | 0.177 | 0.173 | 0.169 | 0.164 | 0.160 | 0.157 | 0.153 | 0.150 | 0.146 | 0.143 | 0.140 | 0.135 | 0.132 |
| 16.5                          | 0.126 | 0.162 | 0.158 | 0.154 | 0.150 | 0.146 | 0.143 | 0.140 | 0.137 | 0.134 | 0.131 | 0.128 | 0.123 | 0.121 |
| 17.0                          | 0.116 | 0.148 | 0.145 | 0.141 | 0.138 | 0.134 | 0.131 | 0.128 | 0.126 | 0.123 | 0.120 | 0.118 | 0.113 | 0.111 |
| 17.5                          | 0.106 | 0.136 | 0.133 | 0.129 | 0.126 | 0.123 | 0.121 | 0.118 | 0.115 | 0.113 | 0.111 | 0.109 | 0.104 | 0.103 |
| 18.0                          | 0.098 | 0.125 | 0.122 | 0.119 | 0.116 | 0.113 | 0.111 | 0.109 | 0.106 | 0.104 | 0.102 | 0.100 | 0.096 | 0.095 |
| 18.5                          | 0.091 | 0.115 | 0.113 | 0.110 | 0.107 | 0.105 | 0.103 | 0.101 | 0.098 | 0.096 | 0.094 | 0.093 | 0.089 | 0.088 |
| 19.0                          | 0.084 | 0.106 | 0.104 | 0.101 | 0.099 | 0.096 | 0.095 | 0.093 | 0.091 | 0.089 | 0.087 | 0.085 | 0.082 | 0.081 |
| 19.5                          | 0.078 | 0.098 | 0.096 | 0.094 | 0.092 | 0.090 | 0.088 | 0.086 | 0.084 | 0.082 | 0.081 | 0.079 | 0.077 | 0.075 |
| 20.0                          | 0.073 | 0.091 | 0.089 | 0.087 | 0.085 | 0.083 | 0.082 | 0.080 | 0.078 | 0.077 | 0.075 | 0.074 | 0.071 | 0.070 |
| 20.5                          | 0.068 | 0.085 | 0.083 | 0.081 | 0.080 | 0.078 | 0.076 | 0.075 | 0.073 | 0.072 | 0.070 | 0.069 | 0.067 | 0.066 |
| 21.0                          | 0.063 | 0.079 | 0.078 | 0.076 | 0.074 | 0.073 | 0.071 | 0.070 | 0.068 | 0.067 | 0.066 | 0.065 | 0.062 | 0.061 |
| 21.5                          | 0.060 | 0.075 | 0.073 | 0.072 | 0.070 | 0.069 | 0.067 | 0.066 | 0.065 | 0.063 | 0.062 | 0.061 | 0.059 | 0.058 |
| 22.0                          | 0.056 | 0.070 | 0.069 | 0.067 | 0.066 | 0.064 | 0.063 | 0.062 | 0.061 | 0.059 | 0.058 | 0.057 | 0.056 | 0.055 |
| 22.5                          | 0.053 | 0.066 | 0.065 | 0.063 | 0.062 | 0.060 | 0.059 | 0.058 | 0.057 | 0.056 | 0.055 | 0.054 | 0.052 | 0.051 |
| 23.0                          | 0.050 | 0.062 | 0.060 | 0.059 | 0.058 | 0.057 | 0.056 | 0.055 | 0.054 | 0.052 | 0.052 | 0.051 | 0.049 | 0.048 |
| 23.5                          | 0.047 | 0.058 | 0.057 | 0.056 | 0.055 | 0.053 | 0.052 | 0.052 | 0.051 | 0.050 | 0.049 | 0.048 | 0.046 | 0.046 |
| 24.0                          | 0.045 | 0.055 | 0.054 | 0.053 | 0.052 | 0.051 | 0.050 | 0.049 | 0.048 | 0.047 | 0.046 | 0.045 | 0.044 | 0.043 |
| 24.5                          | 0.042 | 0.052 | 0.051 | 0.050 | 0.049 | 0.048 | 0.047 | 0.046 | 0.045 | 0.044 | 0.044 | 0.043 | 0.042 | 0.041 |
| 25.0                          | 0.040 | 0.049 | 0.048 | 0.047 | 0.046 | 0.045 | 0.045 | 0.044 | 0.043 | 0.042 | 0.041 | 0.041 | 0.040 | 0.039 |
| 25.5                          | 0.038 | 0.047 | 0.046 | 0.045 | 0.044 | 0.043 | 0.043 | 0.042 | 0.041 | 0.040 | 0.040 | 0.039 | 0.038 | 0.037 |
| 26.0                          | 0.037 | 0.045 | 0.044 | 0.043 | 0.042 | 0.041 | 0.040 | 0.040 | 0.039 | 0.038 | 0.038 | 0.037 | 0.036 | 0.035 |
| 26.5                          | 0.035 | 0.042 | 0.042 | 0.041 | 0.040 | 0.039 | 0.039 | 0.038 | 0.037 | 0.037 | 0.036 | 0.035 | 0.034 | 0.034 |
| 27.0                          | 0.033 | 0.040 | 0.040 | 0.039 | 0.038 | 0.037 | 0.037 | 0.036 | 0.035 | 0.035 | 0.034 | 0.034 | 0.033 | 0.032 |

Table 10-2: C<sub>t</sub> values, Sound Optimized Mode SO1

### 10.3 Sound Curves, Sound Optimized Mode SO1

| Sound Power Level at Hub Height   |  |
|-----------------------------------|--|
| Conditions for Sound Power Level: | Measurement standard IEC 61400-11 ed. 3<br>Maximum turbulence at hub height: 30%<br>Inflow angle (vertical): 0 ±2°<br>Air density: 1.225 kg/m <sup>3</sup> |
| Wind speed at hub height [m/s]    | Sound Power Level at Hub Height [dBA]<br>Sound Optimized Mode SO1<br>(Blades with serrated trailing edge)  |
| 3                                 | 90.9   |
| 4                                 | 91.1   |
| 5                                 | 92.8   |
| 6                                 | 95.9   |
| 7                                 | 99.4   |
| 8                                 | 101.5  |
| 9                                 | 101.9  |
| 10                                | 101.8  |
| 11                                | 102.0  |
| 12                                | 102.0  |
| 13                                | 102.0  |
| 14                                | 102.0  |
| 15                                | 102.0  |
| 16                                | 102.0  |
| 17                                | 102.0  |
| 18                                | 102.0  |
| 19                                | 102.0  |
| 20                                | 102.0  |

*Table 10-3: Sound curves, Sound Optimized Mode SO1*



## 11 Power Curves, Ct Values and Sound Curves, Sound Optimized Mode SO1 (HWO)

**NOTE** The power curves and Ct values presented in Section 11 are only valid for low hub heights, i.e. hub heights ≤ 104 m.

### 11.1 Power Curves, Sound Optimized Mode SO1 (HWO)

| Wind speed [m/s] | Air density [kg/m <sup>3</sup> ] |       |       |       |       |       |       |       |       |       |       |       |       |       |
|------------------|----------------------------------|-------|-------|-------|-------|-------|-------|-------|-------|-------|-------|-------|-------|-------|
|                  | 1.225                            | 0.950 | 0.975 | 1.000 | 1.025 | 1.050 | 1.075 | 1.100 | 1.125 | 1.150 | 1.175 | 1.200 | 1.250 | 1.275 |
| 3.0              | 55                               | 31    | 33    | 35    | 38    | 40    | 42    | 44    | 46    | 48    | 51    | 53    | 57    | 59    |
| 3.5              | 130                              | 89    | 93    | 97    | 100   | 104   | 108   | 111   | 115   | 119   | 122   | 126   | 133   | 137   |
| 4.0              | 220                              | 159   | 165   | 170   | 176   | 182   | 187   | 193   | 198   | 204   | 209   | 215   | 226   | 231   |
| 4.5              | 331                              | 246   | 253   | 261   | 269   | 277   | 284   | 292   | 300   | 308   | 316   | 324   | 339   | 347   |
| 5.0              | 470                              | 352   | 363   | 374   | 385   | 395   | 406   | 417   | 427   | 438   | 449   | 459   | 481   | 491   |
| 5.5              | 638                              | 483   | 497   | 511   | 525   | 539   | 553   | 568   | 582   | 596   | 610   | 624   | 652   | 666   |
| 6.0              | 840                              | 640   | 658   | 676   | 694   | 713   | 731   | 749   | 768   | 786   | 804   | 822   | 859   | 877   |
| 6.5              | 1079                             | 825   | 848   | 871   | 895   | 918   | 941   | 964   | 987   | 1010  | 1033  | 1056  | 1102  | 1125  |
| 7.0              | 1361                             | 1043  | 1072  | 1101  | 1130  | 1159  | 1188  | 1217  | 1246  | 1274  | 1303  | 1332  | 1390  | 1418  |
| 7.5              | 1681                             | 1293  | 1328  | 1364  | 1399  | 1435  | 1470  | 1506  | 1541  | 1576  | 1611  | 1646  | 1716  | 1751  |
| 8.0              | 2039                             | 1574  | 1617  | 1659  | 1702  | 1744  | 1787  | 1829  | 1871  | 1914  | 1955  | 1997  | 2080  | 2122  |
| 8.5              | 2420                             | 1877  | 1927  | 1977  | 2027  | 2077  | 2126  | 2176  | 2225  | 2274  | 2323  | 2372  | 2468  | 2516  |
| 9.0              | 2793                             | 2178  | 2235  | 2292  | 2349  | 2406  | 2462  | 2518  | 2574  | 2630  | 2685  | 2739  | 2845  | 2897  |
| 9.5              | 3119                             | 2458  | 2521  | 2584  | 2647  | 2710  | 2771  | 2831  | 2892  | 2953  | 3008  | 3064  | 3168  | 3218  |
| 10.0             | 3386                             | 2729  | 2796  | 2864  | 2932  | 2999  | 3060  | 3120  | 3181  | 3241  | 3290  | 3338  | 3424  | 3462  |
| 10.5             | 3585                             | 3016  | 3083  | 3151  | 3218  | 3286  | 3336  | 3386  | 3437  | 3487  | 3520  | 3553  | 3608  | 3631  |
| 11.0             | 3716                             | 3278  | 3337  | 3396  | 3456  | 3515  | 3551  | 3587  | 3622  | 3658  | 3677  | 3697  | 3726  | 3736  |
| 11.5             | 3786                             | 3490  | 3537  | 3585  | 3632  | 3679  | 3699  | 3720  | 3740  | 3760  | 3769  | 3777  | 3790  | 3794  |
| 12.0             | 3821                             | 3653  | 3683  | 3712  | 3741  | 3771  | 3781  | 3791  | 3801  | 3811  | 3814  | 3817  | 3822  | 3823  |
| 12.5             | 3840                             | 3758  | 3774  | 3789  | 3805  | 3820  | 3824  | 3829  | 3833  | 3837  | 3838  | 3839  | 3841  | 3842  |
| 13.0             | 3859                             | 3818  | 3826  | 3834  | 3842  | 3850  | 3852  | 3854  | 3856  | 3858  | 3858  | 3859  | 3860  | 3860  |
| 13.5             | 3881                             | 3852  | 3858  | 3863  | 3869  | 3875  | 3876  | 3878  | 3879  | 3880  | 3881  | 3881  | 3881  | 3881  |
| 14.0             | 3900                             | 3886  | 3889  | 3892  | 3895  | 3898  | 3899  | 3899  | 3900  | 3900  | 3900  | 3900  | 3900  | 3900  |
| 14.5             | 3918                             | 3911  | 3912  | 3914  | 3915  | 3917  | 3917  | 3917  | 3918  | 3918  | 3918  | 3918  | 3918  | 3917  |
| 15.0             | 3932                             | 3928  | 3929  | 3930  | 3931  | 3932  | 3932  | 3932  | 3933  | 3933  | 3933  | 3932  | 3932  | 3932  |
| 15.5             | 3945                             | 3943  | 3943  | 3944  | 3945  | 3945  | 3945  | 3946  | 3946  | 3946  | 3946  | 3945  | 3945  | 3945  |
| 16.0             | 3957                             | 3956  | 3957  | 3957  | 3957  | 3958  | 3958  | 3958  | 3957  | 3957  | 3957  | 3957  | 3957  | 3956  |
| 16.5             | 3969                             | 3970  | 3970  | 3970  | 3970  | 3970  | 3970  | 3970  | 3970  | 3970  | 3969  | 3969  | 3969  | 3968  |
| 17.0             | 3981                             | 3982  | 3982  | 3982  | 3983  | 3983  | 3982  | 3982  | 3982  | 3982  | 3982  | 3981  | 3981  | 3981  |
| 17.5             | 3991                             | 3992  | 3992  | 3992  | 3992  | 3992  | 3992  | 3992  | 3992  | 3992  | 3992  | 3992  | 3991  | 3991  |
| 18.0             | 3997                             | 3998  | 3998  | 3998  | 3998  | 3998  | 3998  | 3998  | 3997  | 3997  | 3997  | 3997  | 3997  | 3997  |
| 18.5             | 3999                             | 4000  | 3999  | 3999  | 3999  | 3999  | 3999  | 3999  | 3999  | 3999  | 3999  | 3999  | 3999  | 3999  |
| 19.0             | 4000                             | 4000  | 4000  | 4000  | 4000  | 4000  | 4000  | 4000  | 4000  | 4000  | 4000  | 4000  | 4000  | 4000  |
| 19.5             | 4000                             | 4000  | 4000  | 4000  | 4000  | 4000  | 4000  | 4000  | 4000  | 4000  | 4000  | 4000  | 4000  | 4000  |
| 20.0             | 4000                             | 4000  | 4000  | 4000  | 4000  | 4000  | 4000  | 4000  | 4000  | 4000  | 4000  | 4000  | 4000  | 4000  |
| 20.5             | 4000                             | 4000  | 4000  | 4000  | 4000  | 4000  | 4000  | 4000  | 4000  | 4000  | 4000  | 4000  | 4000  | 4000  |
| 21.0             | 4000                             | 4000  | 4000  | 4000  | 4000  | 4000  | 4000  | 4000  | 4000  | 4000  | 4000  | 4000  | 4000  | 4000  |
| 21.5             | 4000                             | 4000  | 4000  | 4000  | 4000  | 4000  | 4000  | 4000  | 4000  | 4000  | 4000  | 4000  | 4000  | 4000  |
| 22.0             | 4000                             | 4000  | 4000  | 4000  | 4000  | 4000  | 4000  | 4000  | 4000  | 4000  | 4000  | 4000  | 4000  | 4000  |
| 22.5             | 4000                             | 4000  | 4000  | 4000  | 4000  | 4000  | 4000  | 4000  | 4000  | 4000  | 4000  | 4000  | 4000  | 4000  |
| 23.0             | 4000                             | 4000  | 4000  | 4000  | 4000  | 4000  | 4000  | 4000  | 4000  | 4000  | 4000  | 4000  | 4000  | 4000  |
| 23.5             | 4000                             | 4000  | 4000  | 4000  | 4000  | 4000  | 4000  | 4000  | 4000  | 4000  | 4000  | 4000  | 4000  | 4000  |
| 24.0             | 4000                             | 4000  | 4000  | 4000  | 4000  | 4000  | 4000  | 4000  | 4000  | 4000  | 4000  | 4000  | 4000  | 4000  |
| 24.5             | 4000                             | 4000  | 4000  | 4000  | 4000  | 4000  | 4000  | 4000  | 4000  | 4000  | 4000  | 4000  | 4000  | 4000  |
| 25.0             | 4000                             | 4000  | 4000  | 4000  | 4000  | 4000  | 4000  | 4000  | 4000  | 4000  | 4000  | 4000  | 4000  | 4000  |
| 25.5             | 3999                             | 3999  | 3999  | 3999  | 3999  | 3999  | 3999  | 3999  | 3999  | 3999  | 3999  | 3999  | 3999  | 3999  |
| 26.0             | 3987                             | 3987  | 3987  | 3987  | 3987  | 3987  | 3987  | 3987  | 3987  | 3987  | 3987  | 3987  | 3987  | 3987  |
| 26.5             | 3946                             | 3946  | 3946  | 3946  | 3946  | 3946  | 3946  | 3946  | 3946  | 3946  | 3946  | 3946  | 3946  | 3946  |
| 27.0             | 3882                             | 3882  | 3882  | 3882  | 3882  | 3882  | 3882  | 3882  | 3882  | 3882  | 3882  | 3882  | 3882  | 3882  |
| 27.5             | 3731                             | 3731  | 3731  | 3731  | 3731  | 3731  | 3731  | 3731  | 3731  | 3731  | 3731  | 3731  | 3731  | 3731  |
| 28.0             | 3516                             | 3516  | 3516  | 3516  | 3516  | 3516  | 3516  | 3516  | 3516  | 3516  | 3516  | 3516  | 3516  | 3516  |

| <b>Air density [kg/m<sup>3</sup>]</b> |              |              |              |              |              |              |              |              |              |              |              |              |              |              |
|---------------------------------------|--------------|--------------|--------------|--------------|--------------|--------------|--------------|--------------|--------------|--------------|--------------|--------------|--------------|--------------|
| <b>Wind speed [m/s]</b>               | <b>1.225</b> | <b>0.950</b> | <b>0.975</b> | <b>1.000</b> | <b>1.025</b> | <b>1.050</b> | <b>1.075</b> | <b>1.100</b> | <b>1.125</b> | <b>1.150</b> | <b>1.175</b> | <b>1.200</b> | <b>1.250</b> | <b>1.275</b> |
| <b>28.5</b>                           | <b>3279</b>  | 3279         | 3279         | 3279         | 3279         | 3279         | 3279         | 3279         | 3279         | 3279         | 3279         | 3279         | 3279         | 3279         |
| <b>29.0</b>                           | <b>3037</b>  | 3037         | 3037         | 3037         | 3037         | 3037         | 3037         | 3037         | 3037         | 3037         | 3037         | 3037         | 3037         | 3037         |
| <b>29.5</b>                           | <b>2791</b>  | 2791         | 2791         | 2791         | 2791         | 2791         | 2791         | 2791         | 2791         | 2791         | 2791         | 2791         | 2791         | 2791         |
| <b>30.0</b>                           | <b>2549</b>  | 2549         | 2549         | 2549         | 2549         | 2549         | 2549         | 2549         | 2549         | 2549         | 2549         | 2549         | 2549         | 2549         |
| <b>30.5</b>                           | <b>2309</b>  | 2309         | 2309         | 2309         | 2309         | 2309         | 2309         | 2309         | 2309         | 2309         | 2309         | 2309         | 2309         | 2309         |
| <b>31.0</b>                           | <b>2074</b>  | 2075         | 2074         | 2074         | 2074         | 2074         | 2074         | 2074         | 2074         | 2074         | 2074         | 2074         | 2074         | 2074         |
| <b>31.5</b>                           | <b>1869</b>  | 1870         | 1870         | 1870         | 1870         | 1870         | 1870         | 1870         | 1870         | 1870         | 1869         | 1869         | 1869         | 1869         |
| <b>32.0</b>                           | <b>1723</b>  | 1722         | 1722         | 1722         | 1722         | 1722         | 1722         | 1722         | 1722         | 1722         | 1722         | 1722         | 1723         | 1723         |

*Table 11-1: Power curve, Sound Optimized Mode SO1 (HWO)*



**11.2 Ct Values, Sound Optimized Mode SO1 (HWO)**

| Air density kg/m <sup>3</sup> |       |       |       |       |       |       |       |       |       |       |       |       |       |       |
|-------------------------------|-------|-------|-------|-------|-------|-------|-------|-------|-------|-------|-------|-------|-------|-------|
| Wind speed [m/s]              | 1.225 | 0.950 | 0.975 | 1.000 | 1.025 | 1.050 | 1.075 | 1.100 | 1.125 | 1.150 | 1.175 | 1.200 | 1.250 | 1.275 |
| 3.0                           | 0.873 | 0.878 | 0.877 | 0.877 | 0.876 | 0.876 | 0.876 | 0.875 | 0.875 | 0.874 | 0.874 | 0.874 | 0.873 | 0.873 |
| 3.5                           | 0.847 | 0.851 | 0.851 | 0.850 | 0.850 | 0.850 | 0.849 | 0.849 | 0.849 | 0.848 | 0.848 | 0.848 | 0.847 | 0.846 |
| 4.0                           | 0.845 | 0.854 | 0.853 | 0.851 | 0.850 | 0.848 | 0.848 | 0.848 | 0.847 | 0.847 | 0.847 | 0.846 | 0.845 | 0.845 |
| 4.5                           | 0.849 | 0.848 | 0.848 | 0.848 | 0.849 | 0.849 | 0.849 | 0.849 | 0.849 | 0.849 | 0.849 | 0.849 | 0.849 | 0.848 |
| 5.0                           | 0.843 | 0.847 | 0.847 | 0.847 | 0.847 | 0.846 | 0.846 | 0.846 | 0.845 | 0.845 | 0.844 | 0.844 | 0.843 | 0.842 |
| 5.5                           | 0.839 | 0.845 | 0.844 | 0.844 | 0.843 | 0.843 | 0.842 | 0.842 | 0.841 | 0.840 | 0.840 | 0.839 | 0.838 | 0.838 |
| 6.0                           | 0.834 | 0.840 | 0.839 | 0.839 | 0.838 | 0.838 | 0.837 | 0.837 | 0.836 | 0.835 | 0.835 | 0.834 | 0.833 | 0.832 |
| 6.5                           | 0.830 | 0.838 | 0.837 | 0.836 | 0.836 | 0.835 | 0.834 | 0.833 | 0.833 | 0.832 | 0.831 | 0.830 | 0.829 | 0.828 |
| 7.0                           | 0.832 | 0.841 | 0.841 | 0.840 | 0.839 | 0.838 | 0.837 | 0.836 | 0.835 | 0.835 | 0.834 | 0.833 | 0.831 | 0.830 |
| 7.5                           | 0.835 | 0.846 | 0.845 | 0.844 | 0.843 | 0.842 | 0.841 | 0.840 | 0.839 | 0.838 | 0.837 | 0.836 | 0.834 | 0.833 |
| 8.0                           | 0.827 | 0.839 | 0.838 | 0.837 | 0.836 | 0.835 | 0.834 | 0.832 | 0.831 | 0.830 | 0.829 | 0.828 | 0.825 | 0.824 |
| 8.5                           | 0.787 | 0.801 | 0.800 | 0.799 | 0.798 | 0.797 | 0.796 | 0.795 | 0.794 | 0.793 | 0.791 | 0.789 | 0.784 | 0.782 |
| 9.0                           | 0.720 | 0.736 | 0.736 | 0.735 | 0.734 | 0.733 | 0.732 | 0.730 | 0.729 | 0.727 | 0.725 | 0.723 | 0.717 | 0.714 |
| 9.5                           | 0.643 | 0.663 | 0.662 | 0.661 | 0.660 | 0.660 | 0.658 | 0.657 | 0.655 | 0.654 | 0.650 | 0.647 | 0.639 | 0.634 |
| 10.0                          | 0.572 | 0.605 | 0.604 | 0.603 | 0.602 | 0.600 | 0.597 | 0.594 | 0.591 | 0.588 | 0.583 | 0.577 | 0.564 | 0.557 |
| 10.5                          | 0.504 | 0.570 | 0.567 | 0.563 | 0.559 | 0.555 | 0.549 | 0.543 | 0.536 | 0.530 | 0.521 | 0.512 | 0.495 | 0.486 |
| 11.0                          | 0.441 | 0.534 | 0.527 | 0.521 | 0.514 | 0.507 | 0.498 | 0.489 | 0.480 | 0.471 | 0.461 | 0.451 | 0.431 | 0.422 |
| 11.5                          | 0.382 | 0.489 | 0.480 | 0.471 | 0.461 | 0.452 | 0.442 | 0.431 | 0.421 | 0.411 | 0.401 | 0.392 | 0.373 | 0.365 |
| 12.0                          | 0.331 | 0.438 | 0.427 | 0.417 | 0.406 | 0.396 | 0.386 | 0.376 | 0.366 | 0.356 | 0.348 | 0.340 | 0.324 | 0.316 |
| 12.5                          | 0.290 | 0.386 | 0.376 | 0.365 | 0.355 | 0.345 | 0.337 | 0.328 | 0.319 | 0.311 | 0.304 | 0.297 | 0.283 | 0.277 |
| 13.0                          | 0.256 | 0.339 | 0.330 | 0.321 | 0.312 | 0.303 | 0.296 | 0.288 | 0.281 | 0.274 | 0.268 | 0.262 | 0.250 | 0.245 |
| 13.5                          | 0.229 | 0.301 | 0.293 | 0.286 | 0.278 | 0.270 | 0.264 | 0.257 | 0.251 | 0.245 | 0.239 | 0.234 | 0.224 | 0.219 |
| 14.0                          | 0.205 | 0.268 | 0.262 | 0.255 | 0.248 | 0.241 | 0.235 | 0.230 | 0.224 | 0.219 | 0.214 | 0.209 | 0.201 | 0.197 |
| 14.5                          | 0.184 | 0.241 | 0.234 | 0.228 | 0.222 | 0.216 | 0.211 | 0.206 | 0.202 | 0.197 | 0.193 | 0.188 | 0.181 | 0.177 |
| 15.0                          | 0.166 | 0.216 | 0.210 | 0.205 | 0.199 | 0.194 | 0.190 | 0.185 | 0.181 | 0.177 | 0.173 | 0.170 | 0.163 | 0.160 |
| 15.5                          | 0.151 | 0.195 | 0.190 | 0.185 | 0.181 | 0.176 | 0.172 | 0.168 | 0.164 | 0.160 | 0.157 | 0.154 | 0.148 | 0.145 |
| 16.0                          | 0.137 | 0.177 | 0.173 | 0.169 | 0.164 | 0.160 | 0.157 | 0.153 | 0.150 | 0.146 | 0.143 | 0.140 | 0.135 | 0.132 |
| 16.5                          | 0.126 | 0.162 | 0.158 | 0.154 | 0.150 | 0.146 | 0.143 | 0.140 | 0.137 | 0.134 | 0.131 | 0.128 | 0.123 | 0.121 |
| 17.0                          | 0.116 | 0.148 | 0.145 | 0.141 | 0.138 | 0.134 | 0.131 | 0.128 | 0.126 | 0.123 | 0.120 | 0.118 | 0.113 | 0.111 |
| 17.5                          | 0.106 | 0.136 | 0.133 | 0.129 | 0.126 | 0.123 | 0.121 | 0.118 | 0.115 | 0.113 | 0.111 | 0.109 | 0.104 | 0.103 |
| 18.0                          | 0.098 | 0.125 | 0.122 | 0.119 | 0.116 | 0.113 | 0.111 | 0.109 | 0.106 | 0.104 | 0.102 | 0.100 | 0.096 | 0.095 |
| 18.5                          | 0.091 | 0.115 | 0.113 | 0.110 | 0.107 | 0.105 | 0.103 | 0.101 | 0.098 | 0.096 | 0.094 | 0.093 | 0.089 | 0.088 |
| 19.0                          | 0.084 | 0.106 | 0.104 | 0.101 | 0.099 | 0.096 | 0.095 | 0.093 | 0.091 | 0.089 | 0.087 | 0.085 | 0.082 | 0.081 |
| 19.5                          | 0.078 | 0.098 | 0.096 | 0.094 | 0.092 | 0.090 | 0.088 | 0.086 | 0.084 | 0.082 | 0.081 | 0.079 | 0.077 | 0.075 |
| 20.0                          | 0.073 | 0.091 | 0.089 | 0.087 | 0.085 | 0.083 | 0.082 | 0.080 | 0.078 | 0.077 | 0.075 | 0.074 | 0.071 | 0.070 |
| 20.5                          | 0.068 | 0.085 | 0.083 | 0.081 | 0.080 | 0.078 | 0.076 | 0.075 | 0.073 | 0.072 | 0.070 | 0.069 | 0.067 | 0.066 |
| 21.0                          | 0.063 | 0.079 | 0.078 | 0.076 | 0.074 | 0.073 | 0.071 | 0.070 | 0.068 | 0.067 | 0.066 | 0.065 | 0.062 | 0.061 |
| 21.5                          | 0.060 | 0.075 | 0.073 | 0.072 | 0.070 | 0.069 | 0.067 | 0.066 | 0.065 | 0.063 | 0.062 | 0.061 | 0.059 | 0.058 |
| 22.0                          | 0.056 | 0.070 | 0.069 | 0.067 | 0.066 | 0.064 | 0.063 | 0.062 | 0.061 | 0.059 | 0.058 | 0.057 | 0.056 | 0.055 |
| 22.5                          | 0.053 | 0.066 | 0.065 | 0.063 | 0.062 | 0.060 | 0.059 | 0.058 | 0.057 | 0.056 | 0.055 | 0.054 | 0.052 | 0.051 |
| 23.0                          | 0.050 | 0.062 | 0.060 | 0.059 | 0.058 | 0.057 | 0.056 | 0.055 | 0.054 | 0.052 | 0.052 | 0.051 | 0.049 | 0.048 |
| 23.5                          | 0.047 | 0.058 | 0.057 | 0.056 | 0.055 | 0.053 | 0.052 | 0.052 | 0.051 | 0.050 | 0.049 | 0.048 | 0.046 | 0.046 |
| 24.0                          | 0.045 | 0.055 | 0.054 | 0.053 | 0.052 | 0.051 | 0.050 | 0.049 | 0.048 | 0.047 | 0.046 | 0.045 | 0.044 | 0.043 |
| 24.5                          | 0.042 | 0.052 | 0.051 | 0.050 | 0.049 | 0.048 | 0.047 | 0.046 | 0.045 | 0.044 | 0.044 | 0.043 | 0.042 | 0.041 |
| 25.0                          | 0.040 | 0.049 | 0.048 | 0.047 | 0.046 | 0.045 | 0.045 | 0.044 | 0.043 | 0.042 | 0.041 | 0.041 | 0.040 | 0.039 |
| 25.5                          | 0.038 | 0.047 | 0.046 | 0.045 | 0.044 | 0.043 | 0.043 | 0.042 | 0.041 | 0.040 | 0.040 | 0.039 | 0.038 | 0.037 |
| 26.0                          | 0.036 | 0.044 | 0.044 | 0.043 | 0.042 | 0.041 | 0.040 | 0.040 | 0.039 | 0.038 | 0.038 | 0.037 | 0.036 | 0.035 |
| 26.5                          | 0.034 | 0.042 | 0.041 | 0.040 | 0.039 | 0.039 | 0.038 | 0.037 | 0.037 | 0.036 | 0.036 | 0.035 | 0.034 | 0.033 |
| 27.0                          | 0.032 | 0.039 | 0.039 | 0.038 | 0.037 | 0.036 | 0.036 | 0.035 | 0.035 | 0.034 | 0.033 | 0.033 | 0.032 | 0.031 |
| 27.5                          | 0.030 | 0.036 | 0.035 | 0.035 | 0.034 | 0.033 | 0.033 | 0.032 | 0.032 | 0.031 | 0.031 | 0.030 | 0.029 | 0.029 |
| 28.0                          | 0.027 | 0.033 | 0.032 | 0.031 | 0.031 | 0.030 | 0.030 | 0.029 | 0.029 | 0.028 | 0.028 | 0.027 | 0.027 | 0.026 |
| 28.5                          | 0.024 | 0.029 | 0.029 | 0.028 | 0.028 | 0.027 | 0.027 | 0.026 | 0.026 | 0.025 | 0.025 | 0.024 | 0.024 | 0.023 |
| 29.0                          | 0.021 | 0.026 | 0.025 | 0.025 | 0.025 | 0.024 | 0.024 | 0.023 | 0.023 | 0.022 | 0.022 | 0.022 | 0.021 | 0.021 |
| 29.5                          | 0.019 | 0.023 | 0.023 | 0.022 | 0.022 | 0.021 | 0.021 | 0.021 | 0.020 | 0.020 | 0.020 | 0.019 | 0.019 | 0.019 |
| 30.0                          | 0.017 | 0.020 | 0.020 | 0.019 | 0.019 | 0.019 | 0.018 | 0.018 | 0.018 | 0.018 | 0.017 | 0.017 | 0.017 | 0.016 |
| 30.5                          | 0.015 | 0.018 | 0.017 | 0.017 | 0.017 | 0.016 | 0.016 | 0.016 | 0.016 | 0.015 | 0.015 | 0.015 | 0.014 | 0.014 |
| 31.0                          | 0.013 | 0.015 | 0.015 | 0.015 | 0.015 | 0.014 | 0.014 | 0.014 | 0.014 | 0.013 | 0.013 | 0.013 | 0.013 | 0.012 |
| 31.5                          | 0.011 | 0.013 | 0.013 | 0.013 | 0.013 | 0.013 | 0.012 | 0.012 | 0.012 | 0.012 | 0.012 | 0.011 | 0.011 | 0.011 |
| 32.0                          | 0.010 | 0.012 | 0.012 | 0.012 | 0.011 | 0.011 | 0.011 | 0.011 | 0.011 | 0.011 | 0.010 | 0.010 | 0.010 | 0.010 |

Table 11-2: C<sub>t</sub> values, Sound Optimized Mode SO1 (HWO)

### 11.3 Sound Curves, Sound Optimized Mode SO1 (HWO)

| Sound Power Level at Hub Height   |  |
|-----------------------------------|--|
| Conditions for Sound Power Level: | Measurement standard IEC 61400-11 ed. 3<br>Maximum turbulence at hub height: 30%<br>Inflow angle (vertical): 0 ±2°<br>Air density: 1.225 kg/m <sup>3</sup> |
| Wind speed at hub height [m/s]    | Sound Power Level at Hub Height [dBA]<br>Sound Optimized Mode SO1 (HWO)<br>(Blades with serrated trailing edge)  |
| 3                                 | 90.9   |
| 4                                 | 91.1   |
| 5                                 | 92.8   |
| 6                                 | 95.9   |
| 7                                 | 99.4   |
| 8                                 | 101.5  |
| 9                                 | 101.9  |
| 10                                | 101.8  |
| 11                                | 102.0  |
| 12                                | 102.0  |
| 13                                | 102.0  |
| 14                                | 102.0  |
| 15                                | 102.0  |
| 16                                | 102.0  |
| 17                                | 102.0  |
| 18                                | 102.0  |
| 19                                | 102.0  |
| 20                                | 102.0  |

*Table 11-3: Sound curves, Sound Optimized Mode SO1 (HWO)*

## 12 Power Curves, Ct Values and Sound Curves, Sound Optimized Mode SO2

**NOTE** The power curves and Ct values presented in Section 12 are only valid for low hub heights, i.e. hub heights ≤ 104 m.

### 12.1 Power Curves, Sound Optimized Mode SO2

| Wind speed [m/s] | Air density [kg/m <sup>3</sup> ] |       |       |       |       |       |       |       |       |       |       |       |       |       |
|------------------|----------------------------------|-------|-------|-------|-------|-------|-------|-------|-------|-------|-------|-------|-------|-------|
|                  | 1.225                            | 0.950 | 0.975 | 1.000 | 1.025 | 1.050 | 1.075 | 1.100 | 1.125 | 1.150 | 1.175 | 1.200 | 1.250 | 1.275 |
| 3.0              | 55                               | 31    | 33    | 35    | 38    | 40    | 42    | 44    | 46    | 48    | 51    | 53    | 57    | 59    |
| 3.5              | 130                              | 89    | 93    | 97    | 100   | 104   | 108   | 111   | 115   | 119   | 122   | 126   | 133   | 137   |
| 4.0              | 220                              | 159   | 165   | 170   | 176   | 182   | 187   | 193   | 198   | 204   | 209   | 215   | 226   | 231   |
| 4.5              | 331                              | 246   | 253   | 261   | 269   | 277   | 284   | 292   | 300   | 308   | 316   | 324   | 339   | 347   |
| 5.0              | 470                              | 352   | 363   | 374   | 385   | 395   | 406   | 417   | 427   | 438   | 449   | 459   | 481   | 491   |
| 5.5              | 638                              | 483   | 497   | 511   | 525   | 539   | 553   | 568   | 582   | 596   | 610   | 624   | 652   | 666   |
| 6.0              | 841                              | 640   | 658   | 676   | 695   | 713   | 731   | 749   | 768   | 786   | 804   | 822   | 859   | 877   |
| 6.5              | 1079                             | 825   | 848   | 871   | 895   | 918   | 941   | 964   | 987   | 1010  | 1033  | 1056  | 1102  | 1125  |
| 7.0              | 1360                             | 1042  | 1072  | 1101  | 1130  | 1159  | 1188  | 1216  | 1245  | 1274  | 1303  | 1331  | 1388  | 1417  |
| 7.5              | 1655                             | 1285  | 1320  | 1356  | 1391  | 1426  | 1461  | 1496  | 1531  | 1565  | 1595  | 1625  | 1680  | 1705  |
| 8.0              | 1858                             | 1537  | 1576  | 1616  | 1655  | 1694  | 1721  | 1749  | 1777  | 1805  | 1822  | 1840  | 1870  | 1882  |
| 8.5              | 1961                             | 1767  | 1797  | 1827  | 1857  | 1887  | 1901  | 1915  | 1929  | 1943  | 1949  | 1955  | 1965  | 1968  |
| 9.0              | 2027                             | 1940  | 1955  | 1970  | 1985  | 2000  | 2005  | 2010  | 2015  | 2020  | 2022  | 2024  | 2027  | 2028  |
| 9.5              | 2072                             | 2042  | 2048  | 2054  | 2059  | 2065  | 2066  | 2068  | 2069  | 2070  | 2071  | 2071  | 2072  | 2073  |
| 10.0             | 2112                             | 2105  | 2106  | 2107  | 2107  | 2108  | 2109  | 2109  | 2110  | 2111  | 2111  | 2111  | 2112  | 2112  |
| 10.5             | 2146                             | 2156  | 2154  | 2152  | 2151  | 2149  | 2148  | 2148  | 2147  | 2146  | 2146  | 2146  | 2145  | 2145  |
| 11.0             | 2193                             | 2228  | 2223  | 2219  | 2214  | 2210  | 2207  | 2204  | 2201  | 2199  | 2197  | 2195  | 2192  | 2190  |
| 11.5             | 2236                             | 2282  | 2277  | 2271  | 2266  | 2261  | 2257  | 2253  | 2249  | 2245  | 2242  | 2239  | 2233  | 2231  |
| 12.0             | 2291                             | 2341  | 2335  | 2330  | 2325  | 2319  | 2315  | 2311  | 2307  | 2302  | 2299  | 2295  | 2288  | 2285  |
| 12.5             | 2358                             | 2412  | 2406  | 2400  | 2394  | 2388  | 2383  | 2378  | 2374  | 2369  | 2365  | 2361  | 2354  | 2350  |
| 13.0             | 2418                             | 2473  | 2467  | 2461  | 2454  | 2448  | 2443  | 2439  | 2434  | 2429  | 2425  | 2422  | 2415  | 2411  |
| 13.5             | 2471                             | 2522  | 2516  | 2510  | 2504  | 2498  | 2493  | 2489  | 2485  | 2481  | 2477  | 2474  | 2468  | 2464  |
| 14.0             | 2513                             | 2564  | 2558  | 2552  | 2546  | 2540  | 2536  | 2532  | 2528  | 2523  | 2520  | 2517  | 2510  | 2508  |
| 14.5             | 2563                             | 2615  | 2609  | 2604  | 2598  | 2592  | 2587  | 2583  | 2578  | 2574  | 2570  | 2567  | 2560  | 2557  |
| 15.0             | 2667                             | 2712  | 2707  | 2702  | 2698  | 2693  | 2689  | 2685  | 2682  | 2678  | 2674  | 2671  | 2664  | 2660  |
| 15.5             | 2752                             | 2788  | 2784  | 2781  | 2777  | 2774  | 2770  | 2767  | 2764  | 2761  | 2758  | 2755  | 2749  | 2746  |
| 16.0             | 2845                             | 2872  | 2869  | 2867  | 2864  | 2862  | 2859  | 2857  | 2854  | 2852  | 2850  | 2847  | 2842  | 2840  |
| 16.5             | 2920                             | 2938  | 2936  | 2935  | 2933  | 2932  | 2930  | 2929  | 2927  | 2926  | 2924  | 2922  | 2918  | 2916  |
| 17.0             | 2972                             | 2975  | 2975  | 2976  | 2976  | 2976  | 2975  | 2975  | 2975  | 2974  | 2974  | 2973  | 2971  | 2970  |
| 17.5             | 2996                             | 2995  | 2995  | 2995  | 2996  | 2996  | 2996  | 2996  | 2996  | 2996  | 2996  | 2996  | 2996  | 2995  |
| 18.0             | 3005                             | 3004  | 3005  | 3005  | 3005  | 3005  | 3005  | 3005  | 3005  | 3005  | 3005  | 3005  | 3005  | 3005  |
| 18.5             | 3018                             | 3018  | 3018  | 3018  | 3018  | 3018  | 3018  | 3018  | 3018  | 3018  | 3018  | 3018  | 3018  | 3018  |
| 19.0             | 3043                             | 3054  | 3052  | 3051  | 3050  | 3049  | 3048  | 3047  | 3046  | 3045  | 3044  | 3044  | 3042  | 3041  |
| 19.5             | 3085                             | 3099  | 3098  | 3097  | 3096  | 3095  | 3094  | 3092  | 3091  | 3090  | 3088  | 3087  | 3084  | 3083  |
| 20.0             | 3146                             | 3156  | 3155  | 3155  | 3155  | 3155  | 3154  | 3153  | 3152  | 3151  | 3149  | 3148  | 3145  | 3143  |
| 20.5             | 3216                             | 3211  | 3212  | 3213  | 3214  | 3214  | 3215  | 3216  | 3216  | 3217  | 3216  | 3216  | 3215  | 3214  |
| 21.0             | 3273                             | 3257  | 3259  | 3261  | 3263  | 3265  | 3266  | 3268  | 3269  | 3270  | 3271  | 3272  | 3273  | 3274  |
| 21.5             | 3310                             | 3295  | 3296  | 3298  | 3300  | 3302  | 3303  | 3304  | 3305  | 3306  | 3307  | 3308  | 3310  | 3311  |
| 22.0             | 3335                             | 3319  | 3321  | 3323  | 3325  | 3327  | 3329  | 3330  | 3331  | 3333  | 3333  | 3334  | 3335  | 3336  |
| 22.5             | 3363                             | 3346  | 3348  | 3350  | 3352  | 3354  | 3355  | 3357  | 3358  | 3360  | 3361  | 3362  | 3363  | 3364  |
| 23.0             | 3389                             | 3368  | 3370  | 3373  | 3375  | 3377  | 3379  | 3381  | 3383  | 3385  | 3386  | 3387  | 3390  | 3391  |
| 23.5             | 3403                             | 3384  | 3386  | 3388  | 3391  | 3393  | 3394  | 3396  | 3398  | 3399  | 3400  | 3402  | 3404  | 3405  |
| 24.0             | 3412                             | 3394  | 3396  | 3398  | 3400  | 3402  | 3403  | 3405  | 3406  | 3408  | 3409  | 3410  | 3413  | 3414  |
| 24.5             | 3416                             | 3399  | 3400  | 3402  | 3404  | 3406  | 3407  | 3409  | 3410  | 3412  | 3413  | 3414  | 3417  | 3418  |
| 25.0             | 3416                             | 3398  | 3400  | 3403  | 3405  | 3407  | 3409  | 3411  | 3413  | 3414  | 3415  | 3416  | 3417  | 3418  |
| 25.5             | 3404                             | 3378  | 3381  | 3384  | 3386  | 3389  | 3391  | 3394  | 3396  | 3398  | 3400  | 3402  | 3405  | 3407  |
| 26.0             | 3401                             | 3378  | 3380  | 3383  | 3385  | 3387  | 3389  | 3392  | 3394  | 3396  | 3398  | 3399  | 3403  | 3404  |
| 26.5             | 3399                             | 3378  | 3380  | 3382  | 3385  | 3387  | 3389  | 3391  | 3392  | 3394  | 3396  | 3397  | 3400  | 3401  |
| 27.0             | 3381                             | 3365  | 3366  | 3368  | 3369  | 3371  | 3372  | 3374  | 3375  | 3377  | 3378  | 3379  | 3382  | 3383  |

Table 12-1: Power curve, Sound Optimized Mode SO2

**12.2 Ct Values, Sound Optimized Mode SO2**

| Air density kg/m <sup>3</sup> |       |       |       |       |       |       |       |       |       |       |       |       |       |       |
|-------------------------------|-------|-------|-------|-------|-------|-------|-------|-------|-------|-------|-------|-------|-------|-------|
| Wind speed [m/s]              | 1.225 | 0.950 | 0.975 | 1.000 | 1.025 | 1.050 | 1.075 | 1.100 | 1.125 | 1.150 | 1.175 | 1.200 | 1.250 | 1.275 |
| 3.0                           | 0.873 | 0.878 | 0.877 | 0.877 | 0.876 | 0.876 | 0.876 | 0.875 | 0.875 | 0.874 | 0.874 | 0.874 | 0.873 | 0.873 |
| 3.5                           | 0.847 | 0.851 | 0.851 | 0.850 | 0.850 | 0.850 | 0.849 | 0.849 | 0.849 | 0.848 | 0.848 | 0.848 | 0.847 | 0.846 |
| 4.0                           | 0.845 | 0.854 | 0.853 | 0.851 | 0.850 | 0.848 | 0.848 | 0.848 | 0.847 | 0.847 | 0.847 | 0.846 | 0.845 | 0.845 |
| 4.5                           | 0.849 | 0.848 | 0.848 | 0.848 | 0.849 | 0.849 | 0.849 | 0.849 | 0.849 | 0.849 | 0.849 | 0.849 | 0.849 | 0.848 |
| 5.0                           | 0.843 | 0.847 | 0.847 | 0.847 | 0.847 | 0.846 | 0.846 | 0.846 | 0.845 | 0.845 | 0.844 | 0.844 | 0.843 | 0.842 |
| 5.5                           | 0.839 | 0.844 | 0.844 | 0.843 | 0.843 | 0.842 | 0.842 | 0.841 | 0.841 | 0.840 | 0.840 | 0.839 | 0.838 | 0.838 |
| 6.0                           | 0.840 | 0.846 | 0.845 | 0.845 | 0.844 | 0.844 | 0.843 | 0.843 | 0.842 | 0.841 | 0.841 | 0.840 | 0.839 | 0.838 |
| 6.5                           | 0.836 | 0.844 | 0.844 | 0.843 | 0.843 | 0.842 | 0.841 | 0.840 | 0.840 | 0.839 | 0.838 | 0.837 | 0.836 | 0.835 |
| 7.0                           | 0.836 | 0.847 | 0.847 | 0.846 | 0.845 | 0.844 | 0.843 | 0.842 | 0.842 | 0.841 | 0.839 | 0.838 | 0.838 | 0.830 |
| 7.5                           | 0.790 | 0.837 | 0.836 | 0.835 | 0.834 | 0.833 | 0.829 | 0.826 | 0.822 | 0.818 | 0.809 | 0.800 | 0.779 | 0.768 |
| 8.0                           | 0.659 | 0.797 | 0.789 | 0.781 | 0.772 | 0.764 | 0.750 | 0.737 | 0.723 | 0.710 | 0.693 | 0.676 | 0.643 | 0.626 |
| 8.5                           | 0.529 | 0.710 | 0.695 | 0.679 | 0.664 | 0.648 | 0.630 | 0.612 | 0.594 | 0.576 | 0.560 | 0.545 | 0.516 | 0.502 |
| 9.0                           | 0.435 | 0.605 | 0.586 | 0.567 | 0.549 | 0.530 | 0.516 | 0.501 | 0.486 | 0.471 | 0.459 | 0.447 | 0.425 | 0.414 |
| 9.5                           | 0.366 | 0.501 | 0.486 | 0.471 | 0.456 | 0.440 | 0.429 | 0.417 | 0.405 | 0.394 | 0.385 | 0.375 | 0.358 | 0.350 |
| 10.0                          | 0.313 | 0.422 | 0.409 | 0.397 | 0.385 | 0.372 | 0.363 | 0.354 | 0.345 | 0.336 | 0.328 | 0.321 | 0.307 | 0.300 |
| 10.5                          | 0.271 | 0.362 | 0.352 | 0.341 | 0.331 | 0.321 | 0.313 | 0.306 | 0.298 | 0.290 | 0.284 | 0.277 | 0.266 | 0.260 |
| 11.0                          | 0.239 | 0.319 | 0.310 | 0.301 | 0.292 | 0.283 | 0.276 | 0.269 | 0.262 | 0.255 | 0.250 | 0.244 | 0.234 | 0.229 |
| 11.5                          | 0.211 | 0.282 | 0.274 | 0.266 | 0.258 | 0.251 | 0.244 | 0.238 | 0.232 | 0.226 | 0.221 | 0.216 | 0.207 | 0.203 |
| 12.0                          | 0.190 | 0.252 | 0.245 | 0.238 | 0.231 | 0.224 | 0.219 | 0.214 | 0.208 | 0.203 | 0.199 | 0.194 | 0.186 | 0.182 |
| 12.5                          | 0.172 | 0.228 | 0.222 | 0.216 | 0.209 | 0.203 | 0.199 | 0.194 | 0.189 | 0.184 | 0.180 | 0.176 | 0.168 | 0.165 |
| 13.0                          | 0.157 | 0.207 | 0.201 | 0.196 | 0.190 | 0.185 | 0.180 | 0.176 | 0.172 | 0.167 | 0.164 | 0.160 | 0.153 | 0.150 |
| 13.5                          | 0.143 | 0.188 | 0.183 | 0.178 | 0.174 | 0.169 | 0.165 | 0.161 | 0.157 | 0.153 | 0.150 | 0.147 | 0.140 | 0.138 |
| 14.0                          | 0.131 | 0.171 | 0.167 | 0.162 | 0.158 | 0.153 | 0.150 | 0.146 | 0.143 | 0.139 | 0.137 | 0.134 | 0.128 | 0.126 |
| 14.5                          | 0.120 | 0.157 | 0.153 | 0.149 | 0.145 | 0.141 | 0.138 | 0.134 | 0.131 | 0.128 | 0.125 | 0.123 | 0.118 | 0.115 |
| 15.0                          | 0.112 | 0.146 | 0.142 | 0.139 | 0.135 | 0.131 | 0.128 | 0.126 | 0.123 | 0.120 | 0.117 | 0.115 | 0.110 | 0.108 |
| 15.5                          | 0.105 | 0.136 | 0.133 | 0.129 | 0.126 | 0.123 | 0.120 | 0.117 | 0.115 | 0.112 | 0.110 | 0.107 | 0.103 | 0.101 |
| 16.0                          | 0.099 | 0.127 | 0.124 | 0.121 | 0.118 | 0.115 | 0.113 | 0.110 | 0.108 | 0.105 | 0.103 | 0.101 | 0.097 | 0.095 |
| 16.5                          | 0.093 | 0.119 | 0.116 | 0.113 | 0.110 | 0.108 | 0.105 | 0.103 | 0.101 | 0.099 | 0.097 | 0.095 | 0.091 | 0.089 |
| 17.0                          | 0.087 | 0.110 | 0.108 | 0.105 | 0.103 | 0.100 | 0.098 | 0.096 | 0.094 | 0.092 | 0.090 | 0.088 | 0.085 | 0.084 |
| 17.5                          | 0.080 | 0.102 | 0.099 | 0.097 | 0.095 | 0.093 | 0.091 | 0.089 | 0.087 | 0.085 | 0.083 | 0.082 | 0.079 | 0.078 |
| 18.0                          | 0.074 | 0.094 | 0.092 | 0.090 | 0.088 | 0.086 | 0.084 | 0.082 | 0.080 | 0.079 | 0.077 | 0.076 | 0.073 | 0.072 |
| 18.5                          | 0.069 | 0.087 | 0.085 | 0.083 | 0.081 | 0.079 | 0.078 | 0.076 | 0.075 | 0.073 | 0.072 | 0.071 | 0.068 | 0.067 |
| 19.0                          | 0.064 | 0.081 | 0.080 | 0.078 | 0.076 | 0.074 | 0.073 | 0.071 | 0.070 | 0.068 | 0.067 | 0.066 | 0.063 | 0.062 |
| 19.5                          | 0.061 | 0.077 | 0.075 | 0.073 | 0.072 | 0.070 | 0.068 | 0.067 | 0.066 | 0.064 | 0.063 | 0.062 | 0.060 | 0.059 |
| 20.0                          | 0.058 | 0.073 | 0.071 | 0.069 | 0.068 | 0.066 | 0.065 | 0.064 | 0.062 | 0.061 | 0.060 | 0.059 | 0.057 | 0.056 |
| 20.5                          | 0.055 | 0.069 | 0.067 | 0.066 | 0.064 | 0.063 | 0.062 | 0.061 | 0.059 | 0.058 | 0.057 | 0.056 | 0.054 | 0.053 |
| 21.0                          | 0.053 | 0.065 | 0.064 | 0.062 | 0.061 | 0.060 | 0.059 | 0.058 | 0.056 | 0.055 | 0.054 | 0.053 | 0.052 | 0.051 |
| 21.5                          | 0.050 | 0.062 | 0.061 | 0.060 | 0.058 | 0.057 | 0.056 | 0.055 | 0.054 | 0.053 | 0.052 | 0.051 | 0.049 | 0.049 |
| 22.0                          | 0.048 | 0.059 | 0.058 | 0.056 | 0.055 | 0.054 | 0.053 | 0.052 | 0.051 | 0.050 | 0.049 | 0.048 | 0.047 | 0.046 |
| 22.5                          | 0.045 | 0.056 | 0.055 | 0.053 | 0.052 | 0.051 | 0.050 | 0.049 | 0.048 | 0.048 | 0.047 | 0.046 | 0.045 | 0.044 |
| 23.0                          | 0.043 | 0.052 | 0.051 | 0.050 | 0.049 | 0.048 | 0.047 | 0.047 | 0.046 | 0.045 | 0.044 | 0.043 | 0.042 | 0.041 |
| 23.5                          | 0.041 | 0.050 | 0.049 | 0.048 | 0.047 | 0.046 | 0.045 | 0.044 | 0.043 | 0.043 | 0.042 | 0.041 | 0.040 | 0.039 |
| 24.0                          | 0.039 | 0.047 | 0.046 | 0.045 | 0.044 | 0.043 | 0.043 | 0.042 | 0.041 | 0.040 | 0.040 | 0.039 | 0.038 | 0.037 |
| 24.5                          | 0.037 | 0.045 | 0.044 | 0.043 | 0.042 | 0.041 | 0.040 | 0.040 | 0.039 | 0.038 | 0.038 | 0.037 | 0.036 | 0.036 |
| 25.0                          | 0.035 | 0.042 | 0.042 | 0.041 | 0.040 | 0.039 | 0.038 | 0.038 | 0.037 | 0.036 | 0.036 | 0.035 | 0.034 | 0.034 |
| 25.5                          | 0.033 | 0.040 | 0.039 | 0.039 | 0.038 | 0.037 | 0.037 | 0.036 | 0.035 | 0.035 | 0.034 | 0.034 | 0.033 | 0.032 |
| 26.0                          | 0.032 | 0.038 | 0.037 | 0.037 | 0.036 | 0.035 | 0.035 | 0.034 | 0.034 | 0.033 | 0.033 | 0.032 | 0.031 | 0.031 |
| 26.5                          | 0.030 | 0.036 | 0.036 | 0.035 | 0.034 | 0.034 | 0.033 | 0.033 | 0.032 | 0.031 | 0.031 | 0.031 | 0.030 | 0.029 |
| 27.0                          | 0.029 | 0.035 | 0.034 | 0.033 | 0.033 | 0.032 | 0.031 | 0.031 | 0.030 | 0.030 | 0.030 | 0.029 | 0.028 | 0.028 |

Table 12-2: C<sub>t</sub> values, Sound Optimized Mode SO2

### 12.3 Sound Curves, Sound Optimized Mode SO2

| Sound Power Level at Hub Height   |  |
|-----------------------------------|--|
| Conditions for Sound Power Level: | Measurement standard IEC 61400-11 ed. 3<br>Maximum turbulence at hub height: 30%<br>Inflow angle (vertical): 0 ±2°<br>Air density: 1.225 kg/m <sup>3</sup> |
| Wind speed at hub height [m/s]    | Sound Power Level at Hub Height [dBA]<br>Sound Optimized Mode SO2<br>(Blades with serrated trailing edge)  |
| 3                                 | 90.9   |
| 4                                 | 91.1   |
| 5                                 | 92.8   |
| 6                                 | 95.9   |
| 7                                 | 99.0   |
| 8                                 | 99.4   |
| 9                                 | 99.4   |
| 10                                | 99.5   |
| 11                                | 99.5   |
| 12                                | 99.5   |
| 13                                | 99.5   |
| 14                                | 99.4   |
| 15                                | 99.4   |
| 16                                | 99.5   |
| 17                                | 99.5   |
| 18                                | 99.5   |
| 19                                | 99.5   |
| 20                                | 99.5   |

*Table 12-3: Sound curves, Sound Optimized Mode SO2*

### 13 Power Curves, Ct Values and Sound Curves, Sound Optimized Mode SO2 (HWO)

**NOTE** The power curves and Ct values presented in Section 13 are only valid for low hub heights, i.e. hub heights ≤ 104 m.

#### 13.1 Power Curves, Sound Optimized Mode SO2 (HWO)

| Wind speed [m/s] | Air density [kg/m <sup>3</sup> ] |       |       |       |       |       |       |       |       |       |       |       |       |       |
|------------------|----------------------------------|-------|-------|-------|-------|-------|-------|-------|-------|-------|-------|-------|-------|-------|
|                  | 1.225                            | 0.950 | 0.975 | 1.000 | 1.025 | 1.050 | 1.075 | 1.100 | 1.125 | 1.150 | 1.175 | 1.200 | 1.250 | 1.275 |
| 3.0              | 55                               | 31    | 33    | 35    | 38    | 40    | 42    | 44    | 46    | 48    | 51    | 53    | 57    | 59    |
| 3.5              | 130                              | 89    | 93    | 97    | 100   | 104   | 108   | 111   | 115   | 119   | 122   | 126   | 133   | 137   |
| 4.0              | 220                              | 159   | 165   | 170   | 176   | 182   | 187   | 193   | 198   | 204   | 209   | 215   | 226   | 231   |
| 4.5              | 331                              | 246   | 253   | 261   | 269   | 277   | 284   | 292   | 300   | 308   | 316   | 324   | 339   | 347   |
| 5.0              | 470                              | 352   | 363   | 374   | 385   | 395   | 406   | 417   | 427   | 438   | 449   | 459   | 481   | 491   |
| 5.5              | 638                              | 483   | 497   | 511   | 525   | 539   | 553   | 568   | 582   | 596   | 610   | 624   | 652   | 666   |
| 6.0              | 841                              | 640   | 658   | 676   | 695   | 713   | 731   | 749   | 768   | 786   | 804   | 822   | 859   | 877   |
| 6.5              | 1079                             | 825   | 848   | 871   | 895   | 918   | 941   | 964   | 987   | 1010  | 1033  | 1056  | 1102  | 1125  |
| 7.0              | 1360                             | 1042  | 1072  | 1101  | 1130  | 1159  | 1188  | 1216  | 1245  | 1274  | 1303  | 1331  | 1388  | 1417  |
| 7.5              | 1655                             | 1285  | 1320  | 1356  | 1391  | 1426  | 1461  | 1496  | 1531  | 1565  | 1595  | 1625  | 1680  | 1705  |
| 8.0              | 1858                             | 1537  | 1576  | 1616  | 1655  | 1694  | 1721  | 1749  | 1777  | 1805  | 1822  | 1840  | 1870  | 1882  |
| 8.5              | 1961                             | 1767  | 1797  | 1827  | 1857  | 1887  | 1901  | 1915  | 1929  | 1943  | 1949  | 1955  | 1965  | 1968  |
| 9.0              | 2027                             | 1940  | 1955  | 1970  | 1985  | 2000  | 2005  | 2010  | 2015  | 2020  | 2022  | 2024  | 2027  | 2028  |
| 9.5              | 2072                             | 2042  | 2048  | 2054  | 2059  | 2065  | 2066  | 2068  | 2069  | 2070  | 2071  | 2071  | 2072  | 2073  |
| 10.0             | 2112                             | 2105  | 2106  | 2107  | 2107  | 2108  | 2109  | 2109  | 2110  | 2111  | 2111  | 2111  | 2112  | 2112  |
| 10.5             | 2146                             | 2156  | 2154  | 2152  | 2151  | 2149  | 2148  | 2148  | 2147  | 2146  | 2146  | 2146  | 2145  | 2145  |
| 11.0             | 2193                             | 2228  | 2223  | 2219  | 2214  | 2210  | 2207  | 2204  | 2201  | 2199  | 2197  | 2195  | 2192  | 2190  |
| 11.5             | 2236                             | 2282  | 2277  | 2271  | 2266  | 2261  | 2257  | 2253  | 2249  | 2245  | 2242  | 2239  | 2233  | 2231  |
| 12.0             | 2291                             | 2341  | 2335  | 2330  | 2325  | 2319  | 2315  | 2311  | 2307  | 2302  | 2299  | 2295  | 2288  | 2285  |
| 12.5             | 2358                             | 2412  | 2406  | 2400  | 2394  | 2388  | 2383  | 2378  | 2374  | 2369  | 2365  | 2361  | 2354  | 2350  |
| 13.0             | 2418                             | 2473  | 2467  | 2461  | 2454  | 2448  | 2443  | 2439  | 2434  | 2429  | 2425  | 2422  | 2415  | 2411  |
| 13.5             | 2471                             | 2522  | 2516  | 2510  | 2504  | 2498  | 2493  | 2489  | 2485  | 2481  | 2477  | 2474  | 2468  | 2464  |
| 14.0             | 2513                             | 2564  | 2558  | 2552  | 2546  | 2540  | 2536  | 2532  | 2528  | 2523  | 2520  | 2517  | 2510  | 2508  |
| 14.5             | 2563                             | 2615  | 2609  | 2604  | 2598  | 2592  | 2587  | 2583  | 2578  | 2574  | 2570  | 2567  | 2560  | 2557  |
| 15.0             | 2667                             | 2712  | 2707  | 2702  | 2698  | 2693  | 2689  | 2685  | 2682  | 2678  | 2674  | 2671  | 2664  | 2660  |
| 15.5             | 2752                             | 2788  | 2784  | 2781  | 2777  | 2774  | 2770  | 2767  | 2764  | 2761  | 2758  | 2755  | 2749  | 2746  |
| 16.0             | 2845                             | 2872  | 2869  | 2867  | 2864  | 2862  | 2859  | 2857  | 2854  | 2852  | 2850  | 2847  | 2842  | 2840  |
| 16.5             | 2920                             | 2938  | 2936  | 2935  | 2933  | 2932  | 2930  | 2929  | 2927  | 2926  | 2924  | 2922  | 2918  | 2916  |
| 17.0             | 2972                             | 2975  | 2975  | 2976  | 2976  | 2976  | 2975  | 2975  | 2975  | 2974  | 2974  | 2973  | 2971  | 2970  |
| 17.5             | 2996                             | 2995  | 2995  | 2995  | 2996  | 2996  | 2996  | 2996  | 2996  | 2996  | 2996  | 2996  | 2996  | 2995  |
| 18.0             | 3005                             | 3004  | 3005  | 3005  | 3005  | 3005  | 3005  | 3005  | 3005  | 3005  | 3005  | 3005  | 3005  | 3005  |
| 18.5             | 3018                             | 3018  | 3018  | 3018  | 3018  | 3018  | 3018  | 3018  | 3018  | 3018  | 3018  | 3018  | 3018  | 3018  |
| 19.0             | 3043                             | 3054  | 3052  | 3051  | 3050  | 3049  | 3048  | 3047  | 3046  | 3045  | 3044  | 3044  | 3042  | 3041  |
| 19.5             | 3085                             | 3099  | 3098  | 3097  | 3096  | 3095  | 3094  | 3092  | 3091  | 3090  | 3088  | 3087  | 3084  | 3083  |
| 20.0             | 3146                             | 3156  | 3155  | 3155  | 3155  | 3155  | 3154  | 3153  | 3152  | 3151  | 3149  | 3148  | 3145  | 3143  |
| 20.5             | 3216                             | 3211  | 3212  | 3213  | 3214  | 3214  | 3215  | 3216  | 3216  | 3217  | 3216  | 3216  | 3215  | 3214  |
| 21.0             | 3273                             | 3257  | 3259  | 3261  | 3263  | 3265  | 3266  | 3268  | 3269  | 3270  | 3271  | 3272  | 3273  | 3274  |
| 21.5             | 3310                             | 3295  | 3296  | 3298  | 3300  | 3302  | 3303  | 3304  | 3305  | 3306  | 3307  | 3308  | 3310  | 3311  |
| 22.0             | 3335                             | 3319  | 3321  | 3323  | 3325  | 3327  | 3329  | 3330  | 3331  | 3333  | 3333  | 3334  | 3335  | 3336  |
| 22.5             | 3363                             | 3346  | 3348  | 3350  | 3352  | 3354  | 3355  | 3357  | 3358  | 3360  | 3361  | 3362  | 3363  | 3364  |
| 23.0             | 3389                             | 3368  | 3370  | 3373  | 3375  | 3377  | 3379  | 3381  | 3383  | 3385  | 3386  | 3387  | 3390  | 3391  |
| 23.5             | 3403                             | 3384  | 3386  | 3388  | 3391  | 3393  | 3394  | 3396  | 3398  | 3399  | 3400  | 3402  | 3404  | 3405  |
| 24.0             | 3412                             | 3394  | 3396  | 3398  | 3400  | 3402  | 3403  | 3405  | 3406  | 3408  | 3409  | 3410  | 3413  | 3414  |
| 24.5             | 3416                             | 3399  | 3400  | 3402  | 3404  | 3406  | 3407  | 3409  | 3410  | 3412  | 3413  | 3414  | 3417  | 3418  |
| 25.0             | 3416                             | 3398  | 3400  | 3403  | 3405  | 3407  | 3409  | 3411  | 3413  | 3414  | 3415  | 3416  | 3417  | 3418  |
| 25.5             | 3404                             | 3378  | 3381  | 3384  | 3386  | 3389  | 3391  | 3394  | 3396  | 3398  | 3400  | 3402  | 3405  | 3407  |
| 26.0             | 3400                             | 3378  | 3380  | 3382  | 3385  | 3387  | 3389  | 3391  | 3393  | 3395  | 3397  | 3399  | 3402  | 3403  |
| 26.5             | 3387                             | 3367  | 3369  | 3371  | 3373  | 3376  | 3378  | 3380  | 3381  | 3383  | 3385  | 3386  | 3389  | 3390  |
| 27.0             | 3335                             | 3320  | 3321  | 3323  | 3324  | 3326  | 3327  | 3328  | 3330  | 3331  | 3332  | 3334  | 3336  | 3337  |
| 27.5             | 3140                             | 3135  | 3136  | 3136  | 3137  | 3137  | 3138  | 3138  | 3139  | 3139  | 3140  | 3140  | 3141  | 3141  |
| 28.0             | 2823                             | 2821  | 2821  | 2821  | 2822  | 2822  | 2822  | 2822  | 2822  | 2822  | 2823  | 2823  | 2823  | 2824  |



| <b>Air density [kg/m<sup>3</sup>]</b> |              |              |              |              |              |              |              |              |              |              |              |              |              |              |
|---------------------------------------|--------------|--------------|--------------|--------------|--------------|--------------|--------------|--------------|--------------|--------------|--------------|--------------|--------------|--------------|
| <b>Wind speed [m/s]</b>               | <b>1.225</b> | <b>0.950</b> | <b>0.975</b> | <b>1.000</b> | <b>1.025</b> | <b>1.050</b> | <b>1.075</b> | <b>1.100</b> | <b>1.125</b> | <b>1.150</b> | <b>1.175</b> | <b>1.200</b> | <b>1.250</b> | <b>1.275</b> |
| <b>28.5</b>                           | <b>2364</b>  | 2366         | 2366         | 2366         | 2365         | 2365         | 2365         | 2365         | 2365         | 2364         | 2364         | 2364         | 2364         | 2364         |
| <b>29.0</b>                           | <b>1892</b>  | 1895         | 1894         | 1894         | 1894         | 1894         | 1893         | 1893         | 1893         | 1893         | 1893         | 1893         | 1892         | 1892         |
| <b>29.5</b>                           | <b>1570</b>  | 1571         | 1571         | 1571         | 1571         | 1570         | 1570         | 1570         | 1570         | 1570         | 1570         | 1570         | 1570         | 1570         |
| <b>30.0</b>                           | <b>1363</b>  | 1364         | 1364         | 1364         | 1364         | 1364         | 1364         | 1364         | 1364         | 1364         | 1363         | 1363         | 1363         | 1363         |
| <b>30.5</b>                           | <b>1225</b>  | 1225         | 1225         | 1225         | 1225         | 1225         | 1225         | 1225         | 1225         | 1225         | 1225         | 1225         | 1225         | 1225         |
| <b>31.0</b>                           | <b>1150</b>  | 1150         | 1150         | 1150         | 1150         | 1150         | 1150         | 1150         | 1150         | 1150         | 1150         | 1150         | 1150         | 1150         |
| <b>31.5</b>                           | <b>1098</b>  | 1098         | 1098         | 1098         | 1098         | 1098         | 1098         | 1098         | 1098         | 1098         | 1098         | 1098         | 1098         | 1098         |
| <b>32.0</b>                           | <b>1074</b>  | 1074         | 1074         | 1074         | 1074         | 1074         | 1074         | 1074         | 1074         | 1074         | 1074         | 1074         | 1074         | 1075         |

*Table 13-1: Power curve, Sound Optimized Mode SO2 (HWO)*

**13.2 Ct Values, Sound Optimized Mode SO2 (HWO)**

| Air density kg/m <sup>3</sup> |       |       |       |       |       |       |       |       |       |       |       |       |       |       |
|-------------------------------|-------|-------|-------|-------|-------|-------|-------|-------|-------|-------|-------|-------|-------|-------|
| Wind speed [m/s]              | 1.225 | 0.950 | 0.975 | 1.000 | 1.025 | 1.050 | 1.075 | 1.100 | 1.125 | 1.150 | 1.175 | 1.200 | 1.250 | 1.275 |
| 3.0                           | 0.873 | 0.878 | 0.877 | 0.877 | 0.876 | 0.876 | 0.876 | 0.875 | 0.875 | 0.874 | 0.874 | 0.874 | 0.873 | 0.873 |
| 3.5                           | 0.847 | 0.851 | 0.851 | 0.850 | 0.850 | 0.850 | 0.849 | 0.849 | 0.849 | 0.848 | 0.848 | 0.848 | 0.847 | 0.846 |
| 4.0                           | 0.845 | 0.854 | 0.853 | 0.851 | 0.850 | 0.848 | 0.848 | 0.848 | 0.847 | 0.847 | 0.847 | 0.846 | 0.845 | 0.845 |
| 4.5                           | 0.849 | 0.848 | 0.848 | 0.848 | 0.849 | 0.849 | 0.849 | 0.849 | 0.849 | 0.849 | 0.849 | 0.849 | 0.849 | 0.848 |
| 5.0                           | 0.843 | 0.847 | 0.847 | 0.847 | 0.847 | 0.846 | 0.846 | 0.846 | 0.845 | 0.845 | 0.844 | 0.844 | 0.843 | 0.842 |
| 5.5                           | 0.839 | 0.844 | 0.844 | 0.843 | 0.843 | 0.842 | 0.842 | 0.841 | 0.841 | 0.840 | 0.840 | 0.839 | 0.838 | 0.838 |
| 6.0                           | 0.840 | 0.846 | 0.845 | 0.845 | 0.844 | 0.844 | 0.843 | 0.843 | 0.842 | 0.841 | 0.841 | 0.840 | 0.839 | 0.838 |
| 6.5                           | 0.836 | 0.844 | 0.844 | 0.843 | 0.843 | 0.842 | 0.841 | 0.840 | 0.840 | 0.839 | 0.838 | 0.837 | 0.836 | 0.835 |
| 7.0                           | 0.836 | 0.847 | 0.847 | 0.846 | 0.845 | 0.844 | 0.843 | 0.842 | 0.842 | 0.841 | 0.839 | 0.838 | 0.838 | 0.830 |
| 7.5                           | 0.790 | 0.837 | 0.836 | 0.835 | 0.834 | 0.833 | 0.829 | 0.826 | 0.822 | 0.818 | 0.809 | 0.800 | 0.779 | 0.768 |
| 8.0                           | 0.659 | 0.797 | 0.789 | 0.781 | 0.772 | 0.764 | 0.750 | 0.737 | 0.723 | 0.710 | 0.693 | 0.676 | 0.643 | 0.626 |
| 8.5                           | 0.529 | 0.710 | 0.695 | 0.679 | 0.664 | 0.648 | 0.630 | 0.612 | 0.594 | 0.576 | 0.560 | 0.545 | 0.516 | 0.502 |
| 9.0                           | 0.435 | 0.605 | 0.586 | 0.567 | 0.549 | 0.530 | 0.516 | 0.501 | 0.486 | 0.471 | 0.459 | 0.447 | 0.425 | 0.414 |
| 9.5                           | 0.366 | 0.501 | 0.486 | 0.471 | 0.456 | 0.440 | 0.429 | 0.417 | 0.405 | 0.394 | 0.385 | 0.375 | 0.358 | 0.350 |
| 10.0                          | 0.313 | 0.422 | 0.409 | 0.397 | 0.385 | 0.372 | 0.363 | 0.354 | 0.345 | 0.336 | 0.328 | 0.321 | 0.307 | 0.300 |
| 10.5                          | 0.271 | 0.362 | 0.352 | 0.341 | 0.331 | 0.321 | 0.313 | 0.306 | 0.298 | 0.290 | 0.284 | 0.277 | 0.266 | 0.260 |
| 11.0                          | 0.239 | 0.319 | 0.310 | 0.301 | 0.292 | 0.283 | 0.276 | 0.269 | 0.262 | 0.255 | 0.250 | 0.244 | 0.234 | 0.229 |
| 11.5                          | 0.211 | 0.282 | 0.274 | 0.266 | 0.258 | 0.251 | 0.244 | 0.238 | 0.232 | 0.226 | 0.221 | 0.216 | 0.207 | 0.203 |
| 12.0                          | 0.190 | 0.252 | 0.245 | 0.238 | 0.231 | 0.224 | 0.219 | 0.214 | 0.208 | 0.203 | 0.199 | 0.194 | 0.186 | 0.182 |
| 12.5                          | 0.172 | 0.228 | 0.222 | 0.216 | 0.209 | 0.203 | 0.199 | 0.194 | 0.189 | 0.184 | 0.180 | 0.176 | 0.168 | 0.165 |
| 13.0                          | 0.157 | 0.207 | 0.201 | 0.196 | 0.190 | 0.185 | 0.180 | 0.176 | 0.172 | 0.167 | 0.164 | 0.160 | 0.153 | 0.150 |
| 13.5                          | 0.143 | 0.188 | 0.183 | 0.178 | 0.174 | 0.169 | 0.165 | 0.161 | 0.157 | 0.153 | 0.150 | 0.147 | 0.140 | 0.138 |
| 14.0                          | 0.131 | 0.171 | 0.167 | 0.162 | 0.158 | 0.153 | 0.150 | 0.146 | 0.143 | 0.139 | 0.137 | 0.134 | 0.128 | 0.126 |
| 14.5                          | 0.120 | 0.157 | 0.153 | 0.149 | 0.145 | 0.141 | 0.138 | 0.134 | 0.131 | 0.128 | 0.125 | 0.123 | 0.118 | 0.115 |
| 15.0                          | 0.112 | 0.146 | 0.142 | 0.139 | 0.135 | 0.131 | 0.128 | 0.126 | 0.123 | 0.120 | 0.117 | 0.115 | 0.110 | 0.108 |
| 15.5                          | 0.105 | 0.136 | 0.133 | 0.129 | 0.126 | 0.123 | 0.120 | 0.117 | 0.115 | 0.112 | 0.110 | 0.107 | 0.103 | 0.101 |
| 16.0                          | 0.099 | 0.127 | 0.124 | 0.121 | 0.118 | 0.115 | 0.113 | 0.110 | 0.108 | 0.105 | 0.103 | 0.101 | 0.097 | 0.095 |
| 16.5                          | 0.093 | 0.119 | 0.116 | 0.113 | 0.110 | 0.108 | 0.105 | 0.103 | 0.101 | 0.099 | 0.097 | 0.095 | 0.091 | 0.089 |
| 17.0                          | 0.087 | 0.110 | 0.108 | 0.105 | 0.103 | 0.100 | 0.098 | 0.096 | 0.094 | 0.092 | 0.090 | 0.088 | 0.085 | 0.084 |
| 17.5                          | 0.080 | 0.102 | 0.099 | 0.097 | 0.095 | 0.093 | 0.091 | 0.089 | 0.087 | 0.085 | 0.083 | 0.082 | 0.079 | 0.078 |
| 18.0                          | 0.074 | 0.094 | 0.092 | 0.090 | 0.088 | 0.086 | 0.084 | 0.082 | 0.080 | 0.079 | 0.077 | 0.076 | 0.073 | 0.072 |
| 18.5                          | 0.069 | 0.087 | 0.085 | 0.083 | 0.081 | 0.079 | 0.078 | 0.076 | 0.075 | 0.073 | 0.072 | 0.071 | 0.068 | 0.067 |
| 19.0                          | 0.064 | 0.081 | 0.080 | 0.078 | 0.076 | 0.074 | 0.073 | 0.071 | 0.070 | 0.068 | 0.067 | 0.066 | 0.063 | 0.062 |
| 19.5                          | 0.061 | 0.077 | 0.075 | 0.073 | 0.072 | 0.070 | 0.068 | 0.067 | 0.066 | 0.064 | 0.063 | 0.062 | 0.060 | 0.059 |
| 20.0                          | 0.058 | 0.073 | 0.071 | 0.069 | 0.068 | 0.066 | 0.065 | 0.064 | 0.062 | 0.061 | 0.060 | 0.059 | 0.057 | 0.056 |
| 20.5                          | 0.055 | 0.069 | 0.067 | 0.066 | 0.064 | 0.063 | 0.062 | 0.061 | 0.059 | 0.058 | 0.057 | 0.056 | 0.054 | 0.053 |
| 21.0                          | 0.053 | 0.065 | 0.064 | 0.062 | 0.061 | 0.060 | 0.059 | 0.058 | 0.056 | 0.055 | 0.054 | 0.053 | 0.052 | 0.051 |
| 21.5                          | 0.050 | 0.062 | 0.061 | 0.060 | 0.058 | 0.057 | 0.056 | 0.055 | 0.054 | 0.053 | 0.052 | 0.051 | 0.049 | 0.049 |
| 22.0                          | 0.048 | 0.059 | 0.058 | 0.056 | 0.055 | 0.054 | 0.053 | 0.052 | 0.051 | 0.050 | 0.049 | 0.048 | 0.047 | 0.046 |
| 22.5                          | 0.045 | 0.056 | 0.055 | 0.053 | 0.052 | 0.051 | 0.050 | 0.049 | 0.048 | 0.048 | 0.047 | 0.046 | 0.045 | 0.044 |
| 23.0                          | 0.043 | 0.052 | 0.051 | 0.050 | 0.049 | 0.048 | 0.047 | 0.047 | 0.046 | 0.045 | 0.044 | 0.043 | 0.042 | 0.041 |
| 23.5                          | 0.041 | 0.050 | 0.049 | 0.048 | 0.047 | 0.046 | 0.045 | 0.044 | 0.043 | 0.043 | 0.042 | 0.041 | 0.040 | 0.039 |
| 24.0                          | 0.039 | 0.047 | 0.046 | 0.045 | 0.044 | 0.043 | 0.043 | 0.042 | 0.041 | 0.040 | 0.040 | 0.039 | 0.038 | 0.037 |
| 24.5                          | 0.037 | 0.045 | 0.044 | 0.043 | 0.042 | 0.041 | 0.040 | 0.040 | 0.039 | 0.038 | 0.038 | 0.037 | 0.036 | 0.036 |
| 25.0                          | 0.035 | 0.042 | 0.042 | 0.041 | 0.040 | 0.039 | 0.038 | 0.038 | 0.037 | 0.036 | 0.036 | 0.035 | 0.034 | 0.034 |
| 25.5                          | 0.033 | 0.040 | 0.039 | 0.039 | 0.038 | 0.037 | 0.037 | 0.036 | 0.035 | 0.035 | 0.034 | 0.034 | 0.033 | 0.032 |
| 26.0                          | 0.032 | 0.038 | 0.037 | 0.037 | 0.036 | 0.035 | 0.035 | 0.034 | 0.034 | 0.033 | 0.033 | 0.032 | 0.031 | 0.031 |
| 26.5                          | 0.030 | 0.036 | 0.036 | 0.035 | 0.034 | 0.034 | 0.033 | 0.032 | 0.032 | 0.031 | 0.031 | 0.030 | 0.030 | 0.029 |
| 27.0                          | 0.028 | 0.034 | 0.034 | 0.033 | 0.032 | 0.032 | 0.031 | 0.031 | 0.030 | 0.030 | 0.029 | 0.029 | 0.028 | 0.028 |
| 27.5                          | 0.026 | 0.031 | 0.030 | 0.030 | 0.029 | 0.029 | 0.028 | 0.028 | 0.027 | 0.027 | 0.027 | 0.026 | 0.025 | 0.025 |
| 28.0                          | 0.023 | 0.027 | 0.027 | 0.026 | 0.026 | 0.025 | 0.025 | 0.024 | 0.024 | 0.024 | 0.023 | 0.023 | 0.022 | 0.022 |
| 28.5                          | 0.019 | 0.023 | 0.022 | 0.022 | 0.021 | 0.021 | 0.021 | 0.020 | 0.020 | 0.020 | 0.020 | 0.019 | 0.019 | 0.019 |
| 29.0                          | 0.016 | 0.018 | 0.018 | 0.018 | 0.017 | 0.017 | 0.017 | 0.017 | 0.016 | 0.016 | 0.016 | 0.016 | 0.015 | 0.015 |
| 29.5                          | 0.013 | 0.015 | 0.015 | 0.015 | 0.014 | 0.014 | 0.014 | 0.014 | 0.014 | 0.014 | 0.013 | 0.013 | 0.013 | 0.013 |
| 30.0                          | 0.011 | 0.013 | 0.013 | 0.013 | 0.012 | 0.012 | 0.012 | 0.012 | 0.012 | 0.012 | 0.012 | 0.011 | 0.011 | 0.011 |
| 30.5                          | 0.010 | 0.011 | 0.011 | 0.011 | 0.011 | 0.011 | 0.011 | 0.010 | 0.010 | 0.010 | 0.010 | 0.010 | 0.010 | 0.010 |
| 31.0                          | 0.009 | 0.010 | 0.010 | 0.010 | 0.010 | 0.010 | 0.010 | 0.009 | 0.009 | 0.009 | 0.009 | 0.009 | 0.009 | 0.009 |
| 31.5                          | 0.008 | 0.009 | 0.009 | 0.009 | 0.009 | 0.009 | 0.009 | 0.009 | 0.009 | 0.008 | 0.008 | 0.008 | 0.008 | 0.008 |
| 32.0                          | 0.008 | 0.009 | 0.009 | 0.009 | 0.008 | 0.008 | 0.008 | 0.008 | 0.008 | 0.008 | 0.008 | 0.008 | 0.008 | 0.008 |

Table 13-2: C<sub>t</sub> values, Sound Optimized Mode SO2 (HWO)



**13.3 Sound Curves, Sound Optimized Mode SO2 (HWO)**

| Sound Power Level at Hub Height   |  |
|-----------------------------------|--|
| Conditions for Sound Power Level: | Measurement standard IEC 61400-11 ed. 3<br>Maximum turbulence at hub height: 30%<br>Inflow angle (vertical): 0 ±2°<br>Air density: 1.225 kg/m <sup>3</sup> |
| Wind speed at hub height [m/s]    | Sound Power Level at Hub Height [dBA]<br>Sound Optimized Mode SO2 (HWO)<br>(Blades with serrated trailing edge)  |
| 3                                 | 90.9   |
| 4                                 | 91.1   |
| 5                                 | 92.8   |
| 6                                 | 95.9   |
| 7                                 | 99.0   |
| 8                                 | 99.4   |
| 9                                 | 99.4   |
| 10                                | 99.5   |
| 11                                | 99.5   |
| 12                                | 99.5   |
| 13                                | 99.5   |
| 14                                | 99.4   |
| 15                                | 99.4   |
| 16                                | 99.5   |
| 17                                | 99.5   |
| 18                                | 99.5   |
| 19                                | 99.5   |
| 20                                | 99.5   |

Table 13-3: Sound curves, Sound Optimized Mode SO2 (HWO)

## 14 Power Curves, Ct Values and Sound Curves, Sound Optimized Mode SO11

**NOTE** The power curves and Ct values presented in Section 14 are only valid for low hub heights, i.e. hub heights ≤ 104 m.

### 14.1 Power Curves, Sound Optimized Mode SO11

| Wind speed [m/s] | Air density [kg/m <sup>3</sup> ] |       |       |       |       |       |       |       |       |       |       |       |       |       |
|------------------|----------------------------------|-------|-------|-------|-------|-------|-------|-------|-------|-------|-------|-------|-------|-------|
|                  | 1.225                            | 0.950 | 0.975 | 1.000 | 1.025 | 1.050 | 1.075 | 1.100 | 1.125 | 1.150 | 1.175 | 1.200 | 1.250 | 1.275 |
| 3.0              | 19                               | 7     | 8     | 9     | 10    | 11    | 12    | 13    | 14    | 15    | 16    | 17    | 20    | 21    |
| 3.5              | 96                               | 61    | 64    | 67    | 70    | 73    | 77    | 80    | 83    | 86    | 89    | 93    | 99    | 102   |
| 4.0              | 198                              | 141   | 146   | 151   | 157   | 162   | 167   | 172   | 177   | 183   | 188   | 193   | 203   | 209   |
| 4.5              | 323                              | 238   | 246   | 254   | 261   | 269   | 277   | 284   | 292   | 300   | 308   | 315   | 331   | 338   |
| 5.0              | 470                              | 352   | 363   | 374   | 384   | 395   | 406   | 416   | 427   | 438   | 448   | 459   | 480   | 491   |
| 5.5              | 634                              | 480   | 494   | 508   | 522   | 536   | 550   | 564   | 578   | 592   | 606   | 620   | 648   | 662   |
| 6.0              | 812                              | 620   | 637   | 655   | 672   | 690   | 707   | 725   | 742   | 760   | 777   | 794   | 829   | 846   |
| 6.5              | 993                              | 762   | 783   | 804   | 825   | 846   | 867   | 888   | 909   | 930   | 951   | 972   | 1013  | 1034  |
| 7.0              | 1176                             | 906   | 930   | 955   | 980   | 1004  | 1029  | 1054  | 1078  | 1103  | 1127  | 1152  | 1200  | 1225  |
| 7.5              | 1354                             | 1045  | 1073  | 1102  | 1130  | 1158  | 1186  | 1214  | 1242  | 1270  | 1298  | 1326  | 1381  | 1408  |
| 8.0              | 1527                             | 1187  | 1218  | 1250  | 1282  | 1313  | 1345  | 1376  | 1407  | 1439  | 1468  | 1497  | 1553  | 1580  |
| 8.5              | 1705                             | 1396  | 1428  | 1460  | 1493  | 1525  | 1553  | 1582  | 1610  | 1638  | 1660  | 1682  | 1723  | 1741  |
| 9.0              | 1894                             | 1699  | 1723  | 1746  | 1770  | 1794  | 1810  | 1826  | 1843  | 1859  | 1871  | 1882  | 1902  | 1911  |
| 9.5              | 2049                             | 1960  | 1973  | 1986  | 1998  | 2011  | 2017  | 2024  | 2030  | 2036  | 2041  | 2045  | 2052  | 2054  |
| 10.0             | 2152                             | 2123  | 2128  | 2132  | 2137  | 2142  | 2144  | 2145  | 2147  | 2149  | 2150  | 2151  | 2153  | 2154  |
| 10.5             | 2215                             | 2202  | 2204  | 2206  | 2208  | 2210  | 2211  | 2212  | 2213  | 2214  | 2214  | 2214  | 2215  | 2215  |
| 11.0             | 2264                             | 2257  | 2258  | 2259  | 2260  | 2261  | 2262  | 2262  | 2263  | 2263  | 2264  | 2264  | 2264  | 2264  |
| 11.5             | 2307                             | 2304  | 2305  | 2305  | 2306  | 2306  | 2307  | 2307  | 2307  | 2307  | 2307  | 2307  | 2307  | 2307  |
| 12.0             | 2342                             | 2341  | 2342  | 2342  | 2342  | 2342  | 2342  | 2342  | 2342  | 2342  | 2342  | 2342  | 2342  | 2341  |
| 12.5             | 2370                             | 2371  | 2371  | 2371  | 2371  | 2371  | 2371  | 2371  | 2371  | 2370  | 2370  | 2370  | 2370  | 2370  |
| 13.0             | 2396                             | 2398  | 2398  | 2398  | 2398  | 2398  | 2398  | 2398  | 2398  | 2397  | 2397  | 2397  | 2396  | 2396  |
| 13.5             | 2418                             | 2420  | 2420  | 2420  | 2420  | 2420  | 2420  | 2419  | 2419  | 2419  | 2419  | 2419  | 2418  | 2418  |
| 14.0             | 2434                             | 2436  | 2435  | 2435  | 2435  | 2435  | 2435  | 2435  | 2435  | 2435  | 2435  | 2434  | 2434  | 2434  |
| 14.5             | 2448                             | 2450  | 2450  | 2450  | 2450  | 2450  | 2450  | 2449  | 2449  | 2449  | 2449  | 2449  | 2448  | 2448  |
| 15.0             | 2463                             | 2465  | 2465  | 2465  | 2464  | 2464  | 2464  | 2464  | 2464  | 2464  | 2464  | 2463  | 2463  | 2462  |
| 15.5             | 2479                             | 2481  | 2481  | 2481  | 2481  | 2480  | 2480  | 2480  | 2480  | 2480  | 2479  | 2479  | 2478  | 2478  |
| 16.0             | 2496                             | 2499  | 2499  | 2499  | 2498  | 2498  | 2498  | 2498  | 2497  | 2497  | 2497  | 2496  | 2496  | 2495  |
| 16.5             | 2515                             | 2519  | 2518  | 2518  | 2518  | 2517  | 2517  | 2517  | 2516  | 2516  | 2516  | 2515  | 2514  | 2514  |
| 17.0             | 2537                             | 2542  | 2541  | 2541  | 2541  | 2540  | 2540  | 2539  | 2539  | 2538  | 2538  | 2537  | 2536  | 2536  |
| 17.5             | 2562                             | 2568  | 2568  | 2567  | 2567  | 2566  | 2566  | 2565  | 2564  | 2564  | 2563  | 2563  | 2561  | 2560  |
| 18.0             | 2594                             | 2602  | 2602  | 2601  | 2600  | 2600  | 2599  | 2598  | 2597  | 2597  | 2596  | 2595  | 2593  | 2593  |
| 18.5             | 2632                             | 2642  | 2641  | 2640  | 2639  | 2639  | 2638  | 2637  | 2636  | 2635  | 2634  | 2633  | 2631  | 2630  |
| 19.0             | 2671                             | 2681  | 2680  | 2679  | 2679  | 2678  | 2677  | 2676  | 2675  | 2674  | 2673  | 2672  | 2670  | 2669  |
| 19.5             | 2711                             | 2720  | 2720  | 2719  | 2718  | 2718  | 2717  | 2716  | 2715  | 2714  | 2713  | 2712  | 2710  | 2709  |
| 20.0             | 2745                             | 2753  | 2752  | 2752  | 2751  | 2750  | 2750  | 2749  | 2748  | 2747  | 2747  | 2746  | 2744  | 2743  |
| 20.5             | 2771                             | 2776  | 2775  | 2775  | 2775  | 2774  | 2774  | 2773  | 2773  | 2772  | 2772  | 2771  | 2770  | 2769  |
| 21.0             | 2788                             | 2792  | 2791  | 2791  | 2790  | 2790  | 2790  | 2789  | 2789  | 2789  | 2788  | 2788  | 2787  | 2786  |
| 21.5             | 2802                             | 2809  | 2808  | 2808  | 2808  | 2807  | 2806  | 2806  | 2805  | 2804  | 2803  | 2802  | 2801  | 2800  |
| 22.0             | 2830                             | 2842  | 2841  | 2840  | 2839  | 2838  | 2837  | 2836  | 2834  | 2833  | 2832  | 2831  | 2829  | 2828  |
| 22.5             | 2872                             | 2887  | 2886  | 2885  | 2883  | 2882  | 2881  | 2879  | 2878  | 2876  | 2875  | 2873  | 2870  | 2869  |
| 23.0             | 2909                             | 2919  | 2918  | 2918  | 2917  | 2916  | 2915  | 2914  | 2914  | 2913  | 2912  | 2910  | 2908  | 2908  |
| 23.5             | 2938                             | 2946  | 2946  | 2945  | 2944  | 2944  | 2943  | 2942  | 2941  | 2940  | 2940  | 2939  | 2937  | 2936  |
| 24.0             | 2962                             | 2968  | 2967  | 2966  | 2966  | 2966  | 2965  | 2965  | 2964  | 2964  | 2963  | 2962  | 2961  | 2960  |
| 24.5             | 2976                             | 2979  | 2979  | 2979  | 2979  | 2978  | 2978  | 2978  | 2978  | 2977  | 2977  | 2977  | 2976  | 2976  |
| 25.0             | 2983                             | 2984  | 2984  | 2984  | 2984  | 2984  | 2984  | 2984  | 2983  | 2983  | 2983  | 2983  | 2983  | 2982  |
| 25.5             | 2986                             | 2986  | 2986  | 2986  | 2986  | 2986  | 2986  | 2986  | 2986  | 2986  | 2986  | 2986  | 2985  | 2985  |
| 26.0             | 2986                             | 2986  | 2986  | 2986  | 2986  | 2986  | 2986  | 2986  | 2986  | 2986  | 2986  | 2986  | 2986  | 2986  |
| 26.5             | 2986                             | 2986  | 2986  | 2986  | 2986  | 2986  | 2986  | 2986  | 2986  | 2986  | 2986  | 2986  | 2986  | 2986  |
| 27.0             | 2986                             | 2986  | 2986  | 2986  | 2986  | 2986  | 2986  | 2986  | 2986  | 2986  | 2986  | 2986  | 2986  | 2986  |

Table 14-1: Power curve, Sound Optimized Mode SO11

**14.2 Ct Values, Sound Optimized Mode SO11**

| Air density kg/m <sup>3</sup> |       |       |       |       |       |       |       |       |       |       |       |       |       |       |
|-------------------------------|-------|-------|-------|-------|-------|-------|-------|-------|-------|-------|-------|-------|-------|-------|
| Wind speed [m/s]              | 1.225 | 0.950 | 0.975 | 1.000 | 1.025 | 1.050 | 1.075 | 1.100 | 1.125 | 1.150 | 1.175 | 1.200 | 1.250 | 1.275 |
| 3.0                           | 0.907 | 0.918 | 0.917 | 0.916 | 0.915 | 0.914 | 0.913 | 0.912 | 0.911 | 0.910 | 0.909 | 0.908 | 0.906 | 0.905 |
| 3.5                           | 0.875 | 0.883 | 0.882 | 0.881 | 0.881 | 0.880 | 0.879 | 0.879 | 0.878 | 0.877 | 0.876 | 0.876 | 0.874 | 0.873 |
| 4.0                           | 0.848 | 0.858 | 0.857 | 0.856 | 0.855 | 0.854 | 0.853 | 0.852 | 0.851 | 0.850 | 0.849 | 0.849 | 0.847 | 0.847 |
| 4.5                           | 0.832 | 0.833 | 0.833 | 0.833 | 0.833 | 0.833 | 0.833 | 0.833 | 0.833 | 0.833 | 0.832 | 0.832 | 0.832 | 0.831 |
| 5.0                           | 0.832 | 0.836 | 0.836 | 0.836 | 0.835 | 0.835 | 0.835 | 0.834 | 0.834 | 0.834 | 0.833 | 0.833 | 0.832 | 0.831 |
| 5.5                           | 0.782 | 0.788 | 0.787 | 0.787 | 0.786 | 0.786 | 0.785 | 0.785 | 0.784 | 0.784 | 0.783 | 0.783 | 0.782 | 0.781 |
| 6.0                           | 0.706 | 0.711 | 0.711 | 0.710 | 0.710 | 0.709 | 0.709 | 0.708 | 0.708 | 0.707 | 0.707 | 0.707 | 0.706 | 0.705 |
| 6.5                           | 0.636 | 0.640 | 0.640 | 0.640 | 0.639 | 0.639 | 0.638 | 0.638 | 0.637 | 0.637 | 0.636 | 0.636 | 0.635 | 0.635 |
| 7.0                           | 0.573 | 0.578 | 0.577 | 0.577 | 0.576 | 0.576 | 0.576 | 0.575 | 0.575 | 0.575 | 0.574 | 0.574 | 0.573 | 0.573 |
| 7.5                           | 0.517 | 0.521 | 0.521 | 0.520 | 0.520 | 0.520 | 0.519 | 0.519 | 0.519 | 0.518 | 0.518 | 0.518 | 0.517 | 0.516 |
| 8.0                           | 0.467 | 0.473 | 0.473 | 0.472 | 0.472 | 0.472 | 0.471 | 0.471 | 0.470 | 0.470 | 0.469 | 0.468 | 0.465 | 0.463 |
| 8.5                           | 0.425 | 0.457 | 0.455 | 0.453 | 0.451 | 0.449 | 0.446 | 0.443 | 0.440 | 0.437 | 0.433 | 0.429 | 0.421 | 0.416 |
| 9.0                           | 0.393 | 0.471 | 0.464 | 0.457 | 0.449 | 0.442 | 0.435 | 0.428 | 0.421 | 0.414 | 0.407 | 0.400 | 0.386 | 0.379 |
| 9.5                           | 0.358 | 0.464 | 0.453 | 0.442 | 0.432 | 0.421 | 0.411 | 0.401 | 0.392 | 0.382 | 0.374 | 0.366 | 0.350 | 0.343 |
| 10.0                          | 0.318 | 0.424 | 0.413 | 0.401 | 0.389 | 0.378 | 0.368 | 0.359 | 0.350 | 0.341 | 0.333 | 0.326 | 0.311 | 0.305 |
| 10.5                          | 0.279 | 0.370 | 0.360 | 0.350 | 0.340 | 0.330 | 0.322 | 0.314 | 0.307 | 0.299 | 0.292 | 0.286 | 0.273 | 0.268 |
| 11.0                          | 0.246 | 0.324 | 0.315 | 0.307 | 0.298 | 0.290 | 0.283 | 0.276 | 0.269 | 0.263 | 0.257 | 0.251 | 0.241 | 0.236 |
| 11.5                          | 0.218 | 0.285 | 0.277 | 0.270 | 0.263 | 0.256 | 0.250 | 0.244 | 0.238 | 0.232 | 0.227 | 0.223 | 0.213 | 0.209 |
| 12.0                          | 0.193 | 0.252 | 0.245 | 0.239 | 0.233 | 0.227 | 0.221 | 0.216 | 0.211 | 0.206 | 0.202 | 0.198 | 0.190 | 0.186 |
| 12.5                          | 0.173 | 0.224 | 0.218 | 0.213 | 0.207 | 0.202 | 0.197 | 0.193 | 0.188 | 0.184 | 0.180 | 0.176 | 0.169 | 0.166 |
| 13.0                          | 0.155 | 0.200 | 0.195 | 0.190 | 0.185 | 0.181 | 0.177 | 0.173 | 0.169 | 0.165 | 0.162 | 0.158 | 0.152 | 0.149 |
| 13.5                          | 0.140 | 0.180 | 0.176 | 0.172 | 0.168 | 0.163 | 0.160 | 0.156 | 0.153 | 0.149 | 0.146 | 0.143 | 0.138 | 0.135 |
| 14.0                          | 0.127 | 0.162 | 0.159 | 0.155 | 0.151 | 0.147 | 0.144 | 0.141 | 0.138 | 0.135 | 0.132 | 0.129 | 0.124 | 0.122 |
| 14.5                          | 0.115 | 0.147 | 0.143 | 0.140 | 0.137 | 0.133 | 0.130 | 0.128 | 0.125 | 0.122 | 0.120 | 0.117 | 0.113 | 0.111 |
| 15.0                          | 0.104 | 0.133 | 0.130 | 0.127 | 0.124 | 0.121 | 0.118 | 0.116 | 0.113 | 0.111 | 0.108 | 0.106 | 0.102 | 0.100 |
| 15.5                          | 0.095 | 0.121 | 0.118 | 0.116 | 0.113 | 0.110 | 0.108 | 0.106 | 0.103 | 0.101 | 0.099 | 0.097 | 0.094 | 0.092 |
| 16.0                          | 0.088 | 0.111 | 0.109 | 0.106 | 0.104 | 0.101 | 0.099 | 0.097 | 0.095 | 0.093 | 0.091 | 0.089 | 0.086 | 0.085 |
| 16.5                          | 0.081 | 0.102 | 0.100 | 0.098 | 0.095 | 0.093 | 0.091 | 0.089 | 0.087 | 0.086 | 0.084 | 0.082 | 0.079 | 0.078 |
| 17.0                          | 0.075 | 0.095 | 0.093 | 0.090 | 0.088 | 0.086 | 0.084 | 0.083 | 0.081 | 0.079 | 0.078 | 0.076 | 0.074 | 0.072 |
| 17.5                          | 0.070 | 0.088 | 0.086 | 0.084 | 0.082 | 0.080 | 0.078 | 0.077 | 0.075 | 0.074 | 0.072 | 0.071 | 0.069 | 0.067 |
| 18.0                          | 0.065 | 0.082 | 0.080 | 0.078 | 0.077 | 0.075 | 0.073 | 0.072 | 0.070 | 0.069 | 0.068 | 0.066 | 0.064 | 0.063 |
| 18.5                          | 0.061 | 0.077 | 0.075 | 0.074 | 0.072 | 0.070 | 0.069 | 0.068 | 0.066 | 0.065 | 0.064 | 0.062 | 0.060 | 0.059 |
| 19.0                          | 0.058 | 0.072 | 0.070 | 0.069 | 0.067 | 0.066 | 0.064 | 0.063 | 0.062 | 0.061 | 0.060 | 0.059 | 0.057 | 0.056 |
| 19.5                          | 0.054 | 0.068 | 0.066 | 0.065 | 0.063 | 0.062 | 0.061 | 0.060 | 0.059 | 0.057 | 0.056 | 0.055 | 0.053 | 0.053 |
| 20.0                          | 0.051 | 0.064 | 0.063 | 0.061 | 0.060 | 0.059 | 0.057 | 0.056 | 0.055 | 0.054 | 0.053 | 0.052 | 0.051 | 0.050 |
| 20.5                          | 0.049 | 0.060 | 0.059 | 0.058 | 0.056 | 0.055 | 0.054 | 0.053 | 0.052 | 0.051 | 0.050 | 0.049 | 0.048 | 0.047 |
| 21.0                          | 0.046 | 0.057 | 0.055 | 0.054 | 0.053 | 0.052 | 0.051 | 0.050 | 0.049 | 0.048 | 0.047 | 0.047 | 0.045 | 0.044 |
| 21.5                          | 0.044 | 0.054 | 0.053 | 0.052 | 0.051 | 0.049 | 0.049 | 0.048 | 0.047 | 0.046 | 0.045 | 0.044 | 0.043 | 0.042 |
| 22.0                          | 0.041 | 0.051 | 0.050 | 0.049 | 0.048 | 0.047 | 0.046 | 0.045 | 0.044 | 0.044 | 0.043 | 0.042 | 0.041 | 0.040 |
| 22.5                          | 0.040 | 0.049 | 0.048 | 0.047 | 0.046 | 0.045 | 0.044 | 0.043 | 0.042 | 0.042 | 0.041 | 0.040 | 0.039 | 0.038 |
| 23.0                          | 0.038 | 0.046 | 0.045 | 0.044 | 0.043 | 0.043 | 0.042 | 0.041 | 0.040 | 0.040 | 0.039 | 0.038 | 0.037 | 0.037 |
| 23.5                          | 0.036 | 0.044 | 0.043 | 0.042 | 0.041 | 0.041 | 0.040 | 0.039 | 0.038 | 0.038 | 0.037 | 0.037 | 0.035 | 0.035 |
| 24.0                          | 0.034 | 0.042 | 0.041 | 0.040 | 0.040 | 0.039 | 0.038 | 0.037 | 0.037 | 0.036 | 0.035 | 0.035 | 0.034 | 0.033 |
| 24.5                          | 0.033 | 0.040 | 0.039 | 0.038 | 0.038 | 0.037 | 0.036 | 0.036 | 0.035 | 0.034 | 0.034 | 0.033 | 0.032 | 0.032 |
| 25.0                          | 0.031 | 0.038 | 0.037 | 0.036 | 0.036 | 0.035 | 0.034 | 0.034 | 0.033 | 0.033 | 0.032 | 0.032 | 0.031 | 0.030 |
| 25.5                          | 0.030 | 0.036 | 0.036 | 0.035 | 0.034 | 0.034 | 0.033 | 0.032 | 0.032 | 0.031 | 0.031 | 0.030 | 0.030 | 0.029 |
| 26.0                          | 0.029 | 0.034 | 0.034 | 0.033 | 0.033 | 0.032 | 0.031 | 0.031 | 0.030 | 0.030 | 0.029 | 0.029 | 0.028 | 0.028 |
| 26.5                          | 0.027 | 0.033 | 0.032 | 0.032 | 0.031 | 0.030 | 0.030 | 0.029 | 0.029 | 0.029 | 0.028 | 0.028 | 0.027 | 0.027 |
| 27.0                          | 0.026 | 0.031 | 0.031 | 0.030 | 0.030 | 0.029 | 0.029 | 0.028 | 0.028 | 0.027 | 0.027 | 0.027 | 0.026 | 0.025 |

Table 14-2: C<sub>t</sub> values, Sound Optimized Mode SO11

### 14.3 Sound Curves, Sound Optimized Mode SO11

| Sound Power Level at Hub Height   |  |
|-----------------------------------|--|
| Conditions for Sound Power Level: | Measurement standard IEC 61400-11 ed. 3<br>Maximum turbulence at hub height: 30%<br>Inflow angle (vertical): 0 ±2°<br>Air density: 1.225 kg/m <sup>3</sup> |
| Wind speed at hub height [m/s]    | Sound Power Level at Hub Height [dBA]<br>Sound Optimized Mode SO11<br>(Blades with serrated trailing edge)   |
| 3                                 | 92.1   |
| 4                                 | 92.4   |
| 5                                 | 92.9   |
| 6                                 | 94.5   |
| 7                                 | 95.5   |
| 8                                 | 96.8   |
| 9                                 | 98.0   |
| 10                                | 98.8   |
| 11                                | 99.0   |
| 12                                | 99.2   |
| 13                                | 99.2   |
| 14                                | 99.2   |
| 15                                | 99.2   |
| 16                                | 99.2   |
| 17                                | 99.2   |
| 18                                | 99.2   |
| 19                                | 99.2   |
| 20                                | 99.2   |

*Table 14-3: Sound curves, Sound Optimized Mode SO11*

**15 Power Curves, Ct Values and Sound Curves, Sound Optimized Mode SO11 (HWO)**

**NOTE** The power curves and Ct values presented in Section 15 are only valid for low hub heights, i.e. hub heights ≤ 104 m.

**15.1 Power Curves, Sound Optimized Mode SO11 (HWO)**

| Air density [kg/m <sup>3</sup> ] |       |       |       |       |       |       |       |       |       |       |       |       |       |       |
|----------------------------------|-------|-------|-------|-------|-------|-------|-------|-------|-------|-------|-------|-------|-------|-------|
| Wind speed [m/s]                 | 1.225 | 0.950 | 0.975 | 1.000 | 1.025 | 1.050 | 1.075 | 1.100 | 1.125 | 1.150 | 1.175 | 1.200 | 1.250 | 1.275 |
| 3.0                              | 19    | 7     | 8     | 9     | 10    | 11    | 12    | 13    | 14    | 15    | 16    | 17    | 20    | 21    |
| 3.5                              | 96    | 61    | 64    | 67    | 70    | 73    | 77    | 80    | 83    | 86    | 89    | 93    | 99    | 102   |
| 4.0                              | 198   | 141   | 146   | 151   | 157   | 162   | 167   | 172   | 177   | 183   | 188   | 193   | 203   | 209   |
| 4.5                              | 323   | 238   | 246   | 254   | 261   | 269   | 277   | 284   | 292   | 300   | 308   | 315   | 331   | 338   |
| 5.0                              | 470   | 352   | 363   | 374   | 384   | 395   | 406   | 416   | 427   | 438   | 448   | 459   | 480   | 491   |
| 5.5                              | 634   | 480   | 494   | 508   | 522   | 536   | 550   | 564   | 578   | 592   | 606   | 620   | 648   | 662   |
| 6.0                              | 812   | 620   | 637   | 655   | 672   | 690   | 707   | 725   | 742   | 760   | 777   | 794   | 829   | 846   |
| 6.5                              | 993   | 762   | 783   | 804   | 825   | 846   | 867   | 888   | 909   | 930   | 951   | 972   | 1013  | 1034  |
| 7.0                              | 1176  | 906   | 930   | 955   | 980   | 1004  | 1029  | 1054  | 1078  | 1103  | 1127  | 1152  | 1200  | 1225  |
| 7.5                              | 1354  | 1045  | 1073  | 1102  | 1130  | 1158  | 1186  | 1214  | 1242  | 1270  | 1298  | 1326  | 1381  | 1408  |
| 8.0                              | 1527  | 1187  | 1218  | 1250  | 1282  | 1313  | 1345  | 1376  | 1407  | 1439  | 1468  | 1497  | 1553  | 1580  |
| 8.5                              | 1705  | 1396  | 1428  | 1460  | 1493  | 1525  | 1553  | 1582  | 1610  | 1638  | 1660  | 1682  | 1723  | 1741  |
| 9.0                              | 1894  | 1699  | 1723  | 1746  | 1770  | 1794  | 1810  | 1826  | 1843  | 1859  | 1871  | 1882  | 1902  | 1911  |
| 9.5                              | 2049  | 1960  | 1973  | 1986  | 1998  | 2011  | 2017  | 2024  | 2030  | 2036  | 2041  | 2045  | 2052  | 2054  |
| 10.0                             | 2152  | 2123  | 2128  | 2132  | 2137  | 2142  | 2144  | 2145  | 2147  | 2149  | 2150  | 2151  | 2153  | 2154  |
| 10.5                             | 2215  | 2202  | 2204  | 2206  | 2208  | 2210  | 2211  | 2212  | 2213  | 2214  | 2214  | 2214  | 2215  | 2215  |
| 11.0                             | 2264  | 2257  | 2258  | 2259  | 2260  | 2261  | 2262  | 2262  | 2263  | 2263  | 2264  | 2264  | 2264  | 2264  |
| 11.5                             | 2307  | 2304  | 2305  | 2305  | 2306  | 2306  | 2307  | 2307  | 2307  | 2307  | 2307  | 2307  | 2307  | 2307  |
| 12.0                             | 2342  | 2341  | 2342  | 2342  | 2342  | 2342  | 2342  | 2342  | 2342  | 2342  | 2342  | 2342  | 2342  | 2341  |
| 12.5                             | 2370  | 2371  | 2371  | 2371  | 2371  | 2371  | 2371  | 2371  | 2371  | 2370  | 2370  | 2370  | 2370  | 2370  |
| 13.0                             | 2396  | 2398  | 2398  | 2398  | 2398  | 2398  | 2398  | 2398  | 2398  | 2397  | 2397  | 2397  | 2396  | 2396  |
| 13.5                             | 2418  | 2420  | 2420  | 2420  | 2420  | 2420  | 2420  | 2419  | 2419  | 2419  | 2419  | 2419  | 2418  | 2418  |
| 14.0                             | 2434  | 2436  | 2435  | 2435  | 2435  | 2435  | 2435  | 2435  | 2435  | 2435  | 2435  | 2434  | 2434  | 2434  |
| 14.5                             | 2448  | 2450  | 2450  | 2450  | 2450  | 2450  | 2450  | 2449  | 2449  | 2449  | 2449  | 2449  | 2448  | 2448  |
| 15.0                             | 2463  | 2465  | 2465  | 2465  | 2464  | 2464  | 2464  | 2464  | 2464  | 2464  | 2464  | 2463  | 2463  | 2462  |
| 15.5                             | 2479  | 2481  | 2481  | 2481  | 2481  | 2480  | 2480  | 2480  | 2480  | 2480  | 2479  | 2479  | 2478  | 2478  |
| 16.0                             | 2496  | 2499  | 2499  | 2499  | 2498  | 2498  | 2498  | 2498  | 2497  | 2497  | 2497  | 2496  | 2496  | 2495  |
| 16.5                             | 2515  | 2519  | 2518  | 2518  | 2518  | 2517  | 2517  | 2517  | 2516  | 2516  | 2516  | 2515  | 2514  | 2514  |
| 17.0                             | 2537  | 2542  | 2541  | 2541  | 2541  | 2540  | 2540  | 2539  | 2539  | 2538  | 2538  | 2537  | 2536  | 2536  |
| 17.5                             | 2562  | 2568  | 2568  | 2567  | 2567  | 2566  | 2566  | 2565  | 2564  | 2564  | 2563  | 2563  | 2561  | 2560  |
| 18.0                             | 2594  | 2602  | 2602  | 2601  | 2600  | 2600  | 2599  | 2598  | 2597  | 2597  | 2596  | 2595  | 2593  | 2593  |
| 18.5                             | 2632  | 2642  | 2641  | 2640  | 2639  | 2639  | 2638  | 2637  | 2636  | 2635  | 2634  | 2633  | 2631  | 2630  |
| 19.0                             | 2671  | 2681  | 2680  | 2679  | 2679  | 2678  | 2677  | 2676  | 2675  | 2674  | 2673  | 2672  | 2670  | 2669  |
| 19.5                             | 2711  | 2720  | 2720  | 2719  | 2718  | 2718  | 2717  | 2716  | 2715  | 2714  | 2713  | 2712  | 2710  | 2709  |
| 20.0                             | 2745  | 2753  | 2752  | 2752  | 2751  | 2750  | 2750  | 2749  | 2748  | 2747  | 2747  | 2746  | 2744  | 2743  |
| 20.5                             | 2771  | 2776  | 2775  | 2775  | 2775  | 2774  | 2774  | 2773  | 2773  | 2772  | 2772  | 2771  | 2770  | 2769  |
| 21.0                             | 2788  | 2792  | 2791  | 2791  | 2790  | 2790  | 2790  | 2789  | 2789  | 2789  | 2788  | 2788  | 2787  | 2786  |
| 21.5                             | 2802  | 2809  | 2808  | 2808  | 2808  | 2807  | 2806  | 2806  | 2805  | 2804  | 2803  | 2802  | 2801  | 2800  |
| 22.0                             | 2830  | 2842  | 2841  | 2840  | 2839  | 2838  | 2837  | 2836  | 2834  | 2833  | 2832  | 2831  | 2829  | 2828  |
| 22.5                             | 2872  | 2887  | 2886  | 2885  | 2883  | 2882  | 2881  | 2879  | 2878  | 2876  | 2875  | 2873  | 2870  | 2869  |
| 23.0                             | 2909  | 2919  | 2918  | 2918  | 2917  | 2916  | 2915  | 2914  | 2914  | 2913  | 2912  | 2910  | 2908  | 2908  |
| 23.5                             | 2938  | 2946  | 2946  | 2945  | 2944  | 2944  | 2943  | 2942  | 2941  | 2940  | 2940  | 2939  | 2937  | 2936  |
| 24.0                             | 2962  | 2968  | 2967  | 2966  | 2966  | 2966  | 2965  | 2965  | 2964  | 2964  | 2963  | 2962  | 2961  | 2960  |
| 24.5                             | 2976  | 2979  | 2979  | 2979  | 2979  | 2978  | 2978  | 2978  | 2978  | 2977  | 2977  | 2977  | 2976  | 2976  |
| 25.0                             | 2983  | 2984  | 2984  | 2984  | 2984  | 2984  | 2984  | 2984  | 2983  | 2983  | 2983  | 2983  | 2983  | 2982  |
| 25.5                             | 2986  | 2986  | 2986  | 2986  | 2986  | 2986  | 2986  | 2986  | 2986  | 2986  | 2986  | 2986  | 2985  | 2985  |
| 26.0                             | 2986  | 2986  | 2986  | 2986  | 2986  | 2986  | 2986  | 2986  | 2986  | 2986  | 2986  | 2986  | 2986  | 2986  |
| 26.5                             | 2986  | 2986  | 2986  | 2986  | 2986  | 2986  | 2986  | 2986  | 2986  | 2986  | 2986  | 2986  | 2986  | 2986  |
| 27.0                             | 2986  | 2986  | 2986  | 2986  | 2986  | 2986  | 2986  | 2986  | 2986  | 2986  | 2986  | 2986  | 2986  | 2986  |
| 27.5                             | 2986  | 2986  | 2986  | 2986  | 2986  | 2986  | 2986  | 2986  | 2986  | 2986  | 2986  | 2986  | 2986  | 2986  |
| 28.0                             | 2983  | 2983  | 2983  | 2983  | 2983  | 2984  | 2984  | 2984  | 2984  | 2984  | 2983  | 2983  | 2983  | 2983  |

| <b>Air density [kg/m<sup>3</sup>]</b> |              |              |              |              |              |              |              |              |              |              |              |              |              |              |
|---------------------------------------|--------------|--------------|--------------|--------------|--------------|--------------|--------------|--------------|--------------|--------------|--------------|--------------|--------------|--------------|
| <b>Wind speed [m/s]</b>               | <b>1.225</b> | <b>0.950</b> | <b>0.975</b> | <b>1.000</b> | <b>1.025</b> | <b>1.050</b> | <b>1.075</b> | <b>1.100</b> | <b>1.125</b> | <b>1.150</b> | <b>1.175</b> | <b>1.200</b> | <b>1.250</b> | <b>1.275</b> |
| <b>28.5</b>                           | <b>2956</b>  | 2956         | 2956         | 2956         | 2956         | 2956         | 2956         | 2956         | 2956         | 2956         | 2956         | 2956         | 2956         | 2956         |
| <b>29.0</b>                           | <b>2880</b>  | 2880         | 2880         | 2880         | 2880         | 2880         | 2880         | 2880         | 2880         | 2880         | 2880         | 2880         | 2880         | 2880         |
| <b>29.5</b>                           | <b>2737</b>  | 2737         | 2737         | 2737         | 2737         | 2737         | 2737         | 2737         | 2737         | 2737         | 2737         | 2737         | 2737         | 2737         |
| <b>30.0</b>                           | <b>2536</b>  | 2536         | 2536         | 2536         | 2536         | 2536         | 2536         | 2536         | 2536         | 2536         | 2536         | 2536         | 2536         | 2536         |
| <b>30.5</b>                           | <b>2306</b>  | 2306         | 2306         | 2306         | 2306         | 2306         | 2306         | 2306         | 2306         | 2306         | 2306         | 2306         | 2306         | 2306         |
| <b>31.0</b>                           | <b>2072</b>  | 2073         | 2073         | 2073         | 2073         | 2073         | 2073         | 2073         | 2073         | 2073         | 2073         | 2073         | 2073         | 2072         |
| <b>31.5</b>                           | <b>1868</b>  | 1868         | 1868         | 1868         | 1868         | 1868         | 1868         | 1868         | 1868         | 1868         | 1868         | 1868         | 1868         | 1868         |
| <b>32.0</b>                           | <b>1721</b>  | 1721         | 1721         | 1721         | 1721         | 1721         | 1721         | 1721         | 1721         | 1721         | 1721         | 1721         | 1721         | 1721         |

*Table 15-1: Power curve, Sound Optimized Mode SO11 (HWO)*



**15.2 Ct Values, Sound Optimized Mode SO11 (HWO)**

| Air density kg/m <sup>3</sup> |       |       |       |       |       |       |       |       |       |       |       |       |       |       |
|-------------------------------|-------|-------|-------|-------|-------|-------|-------|-------|-------|-------|-------|-------|-------|-------|
| Wind speed [m/s]              | 1.225 | 0.950 | 0.975 | 1.000 | 1.025 | 1.050 | 1.075 | 1.100 | 1.125 | 1.150 | 1.175 | 1.200 | 1.250 | 1.275 |
| 3.0                           | 0.907 | 0.918 | 0.917 | 0.916 | 0.915 | 0.914 | 0.913 | 0.912 | 0.911 | 0.910 | 0.909 | 0.908 | 0.906 | 0.905 |
| 3.5                           | 0.875 | 0.883 | 0.882 | 0.881 | 0.881 | 0.880 | 0.879 | 0.879 | 0.878 | 0.877 | 0.876 | 0.876 | 0.874 | 0.873 |
| 4.0                           | 0.848 | 0.858 | 0.857 | 0.856 | 0.855 | 0.854 | 0.853 | 0.852 | 0.851 | 0.850 | 0.849 | 0.849 | 0.847 | 0.847 |
| 4.5                           | 0.832 | 0.833 | 0.833 | 0.833 | 0.833 | 0.833 | 0.833 | 0.833 | 0.833 | 0.833 | 0.832 | 0.832 | 0.832 | 0.831 |
| 5.0                           | 0.832 | 0.836 | 0.836 | 0.836 | 0.835 | 0.835 | 0.835 | 0.834 | 0.834 | 0.834 | 0.833 | 0.833 | 0.832 | 0.831 |
| 5.5                           | 0.782 | 0.788 | 0.787 | 0.787 | 0.786 | 0.786 | 0.785 | 0.785 | 0.784 | 0.784 | 0.783 | 0.783 | 0.782 | 0.781 |
| 6.0                           | 0.706 | 0.711 | 0.711 | 0.710 | 0.710 | 0.709 | 0.709 | 0.708 | 0.708 | 0.707 | 0.707 | 0.707 | 0.706 | 0.705 |
| 6.5                           | 0.636 | 0.640 | 0.640 | 0.640 | 0.639 | 0.639 | 0.638 | 0.638 | 0.637 | 0.637 | 0.636 | 0.636 | 0.635 | 0.635 |
| 7.0                           | 0.573 | 0.578 | 0.577 | 0.577 | 0.576 | 0.576 | 0.576 | 0.575 | 0.575 | 0.575 | 0.574 | 0.574 | 0.573 | 0.573 |
| 7.5                           | 0.517 | 0.521 | 0.521 | 0.520 | 0.520 | 0.520 | 0.519 | 0.519 | 0.519 | 0.518 | 0.518 | 0.518 | 0.517 | 0.516 |
| 8.0                           | 0.467 | 0.473 | 0.473 | 0.472 | 0.472 | 0.472 | 0.471 | 0.471 | 0.470 | 0.470 | 0.469 | 0.468 | 0.465 | 0.463 |
| 8.5                           | 0.425 | 0.457 | 0.455 | 0.453 | 0.451 | 0.449 | 0.446 | 0.443 | 0.440 | 0.437 | 0.433 | 0.429 | 0.421 | 0.416 |
| 9.0                           | 0.393 | 0.471 | 0.464 | 0.457 | 0.449 | 0.442 | 0.435 | 0.428 | 0.421 | 0.414 | 0.407 | 0.400 | 0.386 | 0.379 |
| 9.5                           | 0.358 | 0.464 | 0.453 | 0.442 | 0.432 | 0.421 | 0.411 | 0.401 | 0.392 | 0.382 | 0.374 | 0.366 | 0.350 | 0.343 |
| 10.0                          | 0.318 | 0.424 | 0.413 | 0.401 | 0.389 | 0.378 | 0.368 | 0.359 | 0.350 | 0.341 | 0.333 | 0.326 | 0.311 | 0.305 |
| 10.5                          | 0.279 | 0.370 | 0.360 | 0.350 | 0.340 | 0.330 | 0.322 | 0.314 | 0.307 | 0.299 | 0.292 | 0.286 | 0.273 | 0.268 |
| 11.0                          | 0.246 | 0.324 | 0.315 | 0.307 | 0.298 | 0.290 | 0.283 | 0.276 | 0.269 | 0.263 | 0.257 | 0.251 | 0.241 | 0.236 |
| 11.5                          | 0.218 | 0.285 | 0.277 | 0.270 | 0.263 | 0.256 | 0.250 | 0.244 | 0.238 | 0.232 | 0.227 | 0.223 | 0.213 | 0.209 |
| 12.0                          | 0.193 | 0.252 | 0.245 | 0.239 | 0.233 | 0.227 | 0.221 | 0.216 | 0.211 | 0.206 | 0.202 | 0.198 | 0.190 | 0.186 |
| 12.5                          | 0.173 | 0.224 | 0.218 | 0.213 | 0.207 | 0.202 | 0.197 | 0.193 | 0.188 | 0.184 | 0.180 | 0.176 | 0.169 | 0.166 |
| 13.0                          | 0.155 | 0.200 | 0.195 | 0.190 | 0.185 | 0.181 | 0.177 | 0.173 | 0.169 | 0.165 | 0.162 | 0.158 | 0.152 | 0.149 |
| 13.5                          | 0.140 | 0.180 | 0.176 | 0.172 | 0.168 | 0.163 | 0.160 | 0.156 | 0.153 | 0.149 | 0.146 | 0.143 | 0.138 | 0.135 |
| 14.0                          | 0.127 | 0.162 | 0.159 | 0.155 | 0.151 | 0.147 | 0.144 | 0.141 | 0.138 | 0.135 | 0.132 | 0.129 | 0.124 | 0.122 |
| 14.5                          | 0.115 | 0.147 | 0.143 | 0.140 | 0.137 | 0.133 | 0.130 | 0.128 | 0.125 | 0.122 | 0.120 | 0.117 | 0.113 | 0.111 |
| 15.0                          | 0.104 | 0.133 | 0.130 | 0.127 | 0.124 | 0.121 | 0.118 | 0.116 | 0.113 | 0.111 | 0.108 | 0.106 | 0.102 | 0.100 |
| 15.5                          | 0.095 | 0.121 | 0.118 | 0.116 | 0.113 | 0.110 | 0.108 | 0.106 | 0.103 | 0.101 | 0.099 | 0.097 | 0.094 | 0.092 |
| 16.0                          | 0.088 | 0.111 | 0.109 | 0.106 | 0.104 | 0.101 | 0.099 | 0.097 | 0.095 | 0.093 | 0.091 | 0.089 | 0.086 | 0.085 |
| 16.5                          | 0.081 | 0.102 | 0.100 | 0.098 | 0.095 | 0.093 | 0.091 | 0.089 | 0.087 | 0.086 | 0.084 | 0.082 | 0.079 | 0.078 |
| 17.0                          | 0.075 | 0.095 | 0.093 | 0.090 | 0.088 | 0.086 | 0.084 | 0.083 | 0.081 | 0.079 | 0.078 | 0.076 | 0.074 | 0.072 |
| 17.5                          | 0.070 | 0.088 | 0.086 | 0.084 | 0.082 | 0.080 | 0.078 | 0.077 | 0.075 | 0.074 | 0.072 | 0.071 | 0.069 | 0.067 |
| 18.0                          | 0.065 | 0.082 | 0.080 | 0.078 | 0.077 | 0.075 | 0.073 | 0.072 | 0.070 | 0.069 | 0.068 | 0.066 | 0.064 | 0.063 |
| 18.5                          | 0.061 | 0.077 | 0.075 | 0.074 | 0.072 | 0.070 | 0.069 | 0.068 | 0.066 | 0.065 | 0.064 | 0.062 | 0.060 | 0.059 |
| 19.0                          | 0.058 | 0.072 | 0.070 | 0.069 | 0.067 | 0.066 | 0.064 | 0.063 | 0.062 | 0.061 | 0.060 | 0.059 | 0.057 | 0.056 |
| 19.5                          | 0.054 | 0.068 | 0.066 | 0.065 | 0.063 | 0.062 | 0.061 | 0.060 | 0.059 | 0.057 | 0.056 | 0.055 | 0.053 | 0.053 |
| 20.0                          | 0.051 | 0.064 | 0.063 | 0.061 | 0.060 | 0.059 | 0.057 | 0.056 | 0.055 | 0.054 | 0.053 | 0.052 | 0.051 | 0.050 |
| 20.5                          | 0.049 | 0.060 | 0.059 | 0.058 | 0.056 | 0.055 | 0.054 | 0.053 | 0.052 | 0.051 | 0.050 | 0.049 | 0.048 | 0.047 |
| 21.0                          | 0.046 | 0.057 | 0.055 | 0.054 | 0.053 | 0.052 | 0.051 | 0.050 | 0.049 | 0.048 | 0.047 | 0.047 | 0.045 | 0.044 |
| 21.5                          | 0.044 | 0.054 | 0.053 | 0.052 | 0.051 | 0.049 | 0.049 | 0.048 | 0.047 | 0.046 | 0.045 | 0.044 | 0.043 | 0.042 |
| 22.0                          | 0.041 | 0.051 | 0.050 | 0.049 | 0.048 | 0.047 | 0.046 | 0.045 | 0.044 | 0.044 | 0.043 | 0.042 | 0.041 | 0.040 |
| 22.5                          | 0.040 | 0.049 | 0.048 | 0.047 | 0.046 | 0.045 | 0.044 | 0.043 | 0.042 | 0.042 | 0.041 | 0.040 | 0.039 | 0.038 |
| 23.0                          | 0.038 | 0.046 | 0.045 | 0.044 | 0.043 | 0.043 | 0.042 | 0.041 | 0.040 | 0.040 | 0.039 | 0.038 | 0.037 | 0.037 |
| 23.5                          | 0.036 | 0.044 | 0.043 | 0.042 | 0.041 | 0.041 | 0.040 | 0.039 | 0.038 | 0.038 | 0.037 | 0.037 | 0.035 | 0.035 |
| 24.0                          | 0.034 | 0.042 | 0.041 | 0.040 | 0.040 | 0.039 | 0.038 | 0.037 | 0.037 | 0.036 | 0.035 | 0.035 | 0.034 | 0.033 |
| 24.5                          | 0.033 | 0.040 | 0.039 | 0.038 | 0.038 | 0.037 | 0.036 | 0.036 | 0.035 | 0.034 | 0.034 | 0.033 | 0.032 | 0.032 |
| 25.0                          | 0.031 | 0.038 | 0.037 | 0.036 | 0.036 | 0.035 | 0.034 | 0.034 | 0.033 | 0.033 | 0.032 | 0.032 | 0.031 | 0.030 |
| 25.5                          | 0.030 | 0.036 | 0.036 | 0.035 | 0.034 | 0.034 | 0.033 | 0.032 | 0.032 | 0.031 | 0.031 | 0.030 | 0.030 | 0.029 |
| 26.0                          | 0.029 | 0.034 | 0.034 | 0.033 | 0.033 | 0.032 | 0.031 | 0.031 | 0.030 | 0.030 | 0.029 | 0.029 | 0.028 | 0.028 |
| 26.5                          | 0.027 | 0.033 | 0.032 | 0.032 | 0.031 | 0.030 | 0.030 | 0.029 | 0.029 | 0.028 | 0.028 | 0.028 | 0.027 | 0.026 |
| 27.0                          | 0.026 | 0.031 | 0.031 | 0.030 | 0.029 | 0.029 | 0.028 | 0.028 | 0.028 | 0.027 | 0.027 | 0.026 | 0.026 | 0.025 |
| 27.5                          | 0.025 | 0.030 | 0.029 | 0.029 | 0.028 | 0.027 | 0.027 | 0.027 | 0.026 | 0.026 | 0.025 | 0.025 | 0.024 | 0.024 |
| 28.0                          | 0.023 | 0.028 | 0.028 | 0.027 | 0.027 | 0.026 | 0.026 | 0.025 | 0.025 | 0.024 | 0.024 | 0.024 | 0.023 | 0.023 |
| 28.5                          | 0.022 | 0.027 | 0.026 | 0.026 | 0.025 | 0.025 | 0.024 | 0.024 | 0.023 | 0.023 | 0.023 | 0.022 | 0.022 | 0.021 |
| 29.0                          | 0.020 | 0.025 | 0.024 | 0.024 | 0.023 | 0.023 | 0.022 | 0.022 | 0.022 | 0.021 | 0.021 | 0.021 | 0.020 | 0.020 |
| 29.5                          | 0.019 | 0.022 | 0.022 | 0.022 | 0.021 | 0.021 | 0.021 | 0.020 | 0.020 | 0.020 | 0.019 | 0.019 | 0.018 | 0.018 |
| 30.0                          | 0.017 | 0.020 | 0.020 | 0.019 | 0.019 | 0.019 | 0.018 | 0.018 | 0.018 | 0.017 | 0.017 | 0.017 | 0.016 | 0.016 |
| 30.5                          | 0.015 | 0.018 | 0.017 | 0.017 | 0.017 | 0.016 | 0.016 | 0.016 | 0.016 | 0.015 | 0.015 | 0.015 | 0.014 | 0.014 |
| 31.0                          | 0.013 | 0.015 | 0.015 | 0.015 | 0.015 | 0.014 | 0.014 | 0.014 | 0.014 | 0.013 | 0.013 | 0.013 | 0.013 | 0.012 |
| 31.5                          | 0.011 | 0.013 | 0.013 | 0.013 | 0.013 | 0.013 | 0.012 | 0.012 | 0.012 | 0.012 | 0.012 | 0.011 | 0.011 | 0.011 |
| 32.0                          | 0.010 | 0.012 | 0.012 | 0.012 | 0.011 | 0.011 | 0.011 | 0.011 | 0.011 | 0.011 | 0.010 | 0.010 | 0.010 | 0.010 |

Table 15-2: C<sub>t</sub> values, Sound Optimized Mode SO11 (HWO)

### 15.3 Sound Curves, Sound Optimized Mode SO11 (HWO)

| Sound Power Level at Hub Height   |  |
|-----------------------------------|--|
| Conditions for Sound Power Level: | Measurement standard IEC 61400-11 ed. 3<br>Maximum turbulence at hub height: 30%<br>Inflow angle (vertical): 0 ±2°<br>Air density: 1.225 kg/m <sup>3</sup> |
| Wind speed at hub height [m/s]    | Sound Power Level at Hub Height [dBA]<br>Sound Optimized Mode SO11 (HWO)<br>(Blades with serrated trailing edge)   |
| 3                                 | 92.1   |
| 4                                 | 92.4   |
| 5                                 | 92.9   |
| 6                                 | 94.5   |
| 7                                 | 95.5   |
| 8                                 | 96.8   |
| 9                                 | 98.0   |
| 10                                | 98.8   |
| 11                                | 99.0   |
| 12                                | 99.2   |
| 13                                | 99.2   |
| 14                                | 99.2   |
| 15                                | 99.2   |
| 16                                | 99.2   |
| 17                                | 99.2   |
| 18                                | 99.2   |
| 19                                | 99.2   |
| 20                                | 99.2   |

*Table 15-3: Sound curves, Sound Optimized Mode SO11 (HWO)*



**16 Power Curves, Ct Values and Sound Curves, Sound Optimized Mode SO12**

**NOTE** The power curves and Ct values presented in Section 16 are only valid for low hub heights, i.e. hub heights ≤ 104 m.

**16.1 Power Curves, Sound Optimized Mode SO12**

| Wind speed [m/s] | Air density [kg/m <sup>3</sup> ] |       |       |       |       |       |       |       |       |       |       |       |       |       |
|------------------|----------------------------------|-------|-------|-------|-------|-------|-------|-------|-------|-------|-------|-------|-------|-------|
|                  | 1.225                            | 0.950 | 0.975 | 1.000 | 1.025 | 1.050 | 1.075 | 1.100 | 1.125 | 1.150 | 1.175 | 1.200 | 1.250 | 1.275 |
| 3.0              | 19                               | 7     | 8     | 9     | 10    | 11    | 12    | 13    | 14    | 15    | 16    | 17    | 20    | 21    |
| 3.5              | 96                               | 61    | 64    | 67    | 70    | 73    | 77    | 80    | 83    | 86    | 89    | 93    | 99    | 102   |
| 4.0              | 198                              | 141   | 146   | 151   | 157   | 162   | 167   | 172   | 177   | 183   | 188   | 193   | 203   | 209   |
| 4.5              | 323                              | 238   | 246   | 254   | 261   | 269   | 277   | 284   | 292   | 300   | 308   | 315   | 331   | 338   |
| 5.0              | 470                              | 352   | 363   | 374   | 384   | 395   | 406   | 416   | 427   | 438   | 448   | 459   | 480   | 491   |
| 5.5              | 637                              | 483   | 497   | 511   | 525   | 539   | 553   | 567   | 581   | 595   | 609   | 623   | 651   | 665   |
| 6.0              | 830                              | 633   | 651   | 669   | 687   | 705   | 723   | 741   | 759   | 777   | 794   | 812   | 848   | 865   |
| 6.5              | 1037                             | 796   | 818   | 840   | 862   | 884   | 906   | 928   | 950   | 972   | 994   | 1016  | 1059  | 1081  |
| 7.0              | 1244                             | 958   | 984   | 1010  | 1036  | 1063  | 1089  | 1115  | 1141  | 1167  | 1192  | 1218  | 1270  | 1295  |
| 7.5              | 1414                             | 1092  | 1121  | 1151  | 1180  | 1210  | 1239  | 1269  | 1298  | 1327  | 1356  | 1385  | 1444  | 1472  |
| 8.0              | 1573                             | 1218  | 1250  | 1283  | 1315  | 1348  | 1380  | 1412  | 1445  | 1477  | 1509  | 1541  | 1605  | 1636  |
| 8.5              | 1805                             | 1434  | 1469  | 1505  | 1541  | 1576  | 1610  | 1644  | 1677  | 1711  | 1742  | 1774  | 1835  | 1865  |
| 9.0              | 2100                             | 1817  | 1848  | 1880  | 1911  | 1942  | 1967  | 1991  | 2015  | 2040  | 2060  | 2080  | 2118  | 2136  |
| 9.5              | 2301                             | 2145  | 2167  | 2190  | 2212  | 2234  | 2246  | 2257  | 2269  | 2280  | 2287  | 2294  | 2307  | 2312  |
| 10.0             | 2382                             | 2331  | 2341  | 2350  | 2360  | 2370  | 2373  | 2375  | 2377  | 2379  | 2380  | 2381  | 2383  | 2383  |
| 10.5             | 2422                             | 2407  | 2409  | 2412  | 2415  | 2417  | 2418  | 2419  | 2420  | 2421  | 2421  | 2422  | 2423  | 2423  |
| 11.0             | 2458                             | 2450  | 2452  | 2453  | 2454  | 2455  | 2456  | 2456  | 2457  | 2457  | 2458  | 2458  | 2458  | 2458  |
| 11.5             | 2486                             | 2483  | 2483  | 2484  | 2484  | 2485  | 2485  | 2485  | 2486  | 2486  | 2486  | 2486  | 2486  | 2486  |
| 12.0             | 2510                             | 2509  | 2509  | 2509  | 2509  | 2510  | 2510  | 2510  | 2510  | 2510  | 2510  | 2510  | 2509  | 2509  |
| 12.5             | 2534                             | 2535  | 2535  | 2535  | 2535  | 2535  | 2535  | 2535  | 2535  | 2534  | 2534  | 2534  | 2534  | 2533  |
| 13.0             | 2567                             | 2570  | 2570  | 2570  | 2570  | 2570  | 2570  | 2569  | 2569  | 2568  | 2568  | 2568  | 2567  | 2566  |
| 13.5             | 2621                             | 2626  | 2625  | 2625  | 2625  | 2625  | 2624  | 2624  | 2623  | 2623  | 2622  | 2621  | 2620  | 2619  |
| 14.0             | 2679                             | 2685  | 2684  | 2684  | 2684  | 2684  | 2683  | 2682  | 2682  | 2681  | 2680  | 2680  | 2678  | 2677  |
| 14.5             | 2740                             | 2746  | 2746  | 2746  | 2745  | 2745  | 2744  | 2744  | 2743  | 2742  | 2741  | 2741  | 2739  | 2738  |
| 15.0             | 2803                             | 2810  | 2810  | 2809  | 2809  | 2808  | 2808  | 2807  | 2806  | 2805  | 2804  | 2804  | 2802  | 2800  |
| 15.5             | 2863                             | 2872  | 2871  | 2871  | 2870  | 2870  | 2869  | 2868  | 2867  | 2866  | 2865  | 2864  | 2862  | 2861  |
| 16.0             | 2922                             | 2931  | 2931  | 2930  | 2930  | 2929  | 2928  | 2927  | 2927  | 2926  | 2925  | 2924  | 2921  | 2920  |
| 16.5             | 2978                             | 2987  | 2986  | 2986  | 2986  | 2985  | 2984  | 2983  | 2982  | 2981  | 2980  | 2979  | 2977  | 2976  |
| 17.0             | 3030                             | 3040  | 3039  | 3038  | 3038  | 3037  | 3036  | 3035  | 3035  | 3034  | 3033  | 3032  | 3029  | 3028  |
| 17.5             | 3081                             | 3090  | 3090  | 3089  | 3088  | 3088  | 3087  | 3086  | 3085  | 3084  | 3083  | 3082  | 3080  | 3078  |
| 18.0             | 3131                             | 3141  | 3141  | 3140  | 3139  | 3138  | 3137  | 3136  | 3135  | 3134  | 3133  | 3132  | 3129  | 3128  |
| 18.5             | 3182                             | 3194  | 3193  | 3192  | 3192  | 3191  | 3190  | 3189  | 3187  | 3186  | 3185  | 3184  | 3181  | 3180  |
| 19.0             | 3236                             | 3249  | 3248  | 3247  | 3246  | 3245  | 3244  | 3243  | 3241  | 3240  | 3239  | 3238  | 3235  | 3234  |
| 19.5             | 3290                             | 3302  | 3301  | 3300  | 3299  | 3298  | 3297  | 3296  | 3295  | 3294  | 3292  | 3291  | 3288  | 3286  |
| 20.0             | 3339                             | 3351  | 3350  | 3349  | 3348  | 3348  | 3346  | 3345  | 3344  | 3343  | 3342  | 3340  | 3338  | 3336  |
| 20.5             | 3384                             | 3396  | 3395  | 3394  | 3393  | 3392  | 3391  | 3390  | 3389  | 3388  | 3387  | 3386  | 3383  | 3382  |
| 21.0             | 3428                             | 3439  | 3438  | 3437  | 3436  | 3436  | 3435  | 3433  | 3432  | 3431  | 3430  | 3429  | 3426  | 3425  |
| 21.5             | 3470                             | 3481  | 3480  | 3479  | 3478  | 3478  | 3476  | 3475  | 3474  | 3473  | 3472  | 3471  | 3468  | 3467  |
| 22.0             | 3510                             | 3522  | 3521  | 3520  | 3519  | 3518  | 3517  | 3516  | 3515  | 3514  | 3513  | 3512  | 3509  | 3508  |
| 22.5             | 3547                             | 3557  | 3556  | 3555  | 3554  | 3553  | 3553  | 3552  | 3551  | 3550  | 3549  | 3548  | 3546  | 3544  |
| 23.0             | 3574                             | 3582  | 3582  | 3581  | 3581  | 3580  | 3579  | 3579  | 3578  | 3577  | 3576  | 3575  | 3574  | 3573  |
| 23.5             | 3598                             | 3603  | 3603  | 3602  | 3602  | 3602  | 3601  | 3601  | 3600  | 3599  | 3599  | 3598  | 3597  | 3596  |
| 24.0             | 3614                             | 3618  | 3618  | 3617  | 3617  | 3616  | 3616  | 3616  | 3615  | 3615  | 3615  | 3614  | 3613  | 3613  |
| 24.5             | 3624                             | 3626  | 3626  | 3626  | 3626  | 3626  | 3625  | 3625  | 3625  | 3625  | 3625  | 3624  | 3624  | 3624  |
| 25.0             | 3630                             | 3632  | 3632  | 3631  | 3631  | 3631  | 3631  | 3631  | 3631  | 3631  | 3630  | 3630  | 3630  | 3630  |
| 25.5             | 3634                             | 3634  | 3634  | 3634  | 3634  | 3634  | 3634  | 3634  | 3634  | 3634  | 3634  | 3634  | 3634  | 3634  |
| 26.0             | 3635                             | 3635  | 3635  | 3635  | 3635  | 3635  | 3635  | 3635  | 3635  | 3635  | 3635  | 3635  | 3635  | 3635  |
| 26.5             | 3636                             | 3636  | 3636  | 3636  | 3636  | 3636  | 3636  | 3636  | 3636  | 3636  | 3636  | 3636  | 3636  | 3636  |
| 27.0             | 3636                             | 3636  | 3636  | 3636  | 3636  | 3636  | 3636  | 3636  | 3636  | 3636  | 3636  | 3636  | 3635  | 3635  |

Table 16-1: Power curve, Sound Optimized Mode SO12

**16.2 Ct Values, Sound Optimized Mode SO12**

| Air density kg/m <sup>3</sup> |       |       |       |       |       |       |       |       |       |       |       |       |       |       |
|-------------------------------|-------|-------|-------|-------|-------|-------|-------|-------|-------|-------|-------|-------|-------|-------|
| Wind speed [m/s]              | 1.225 | 0.950 | 0.975 | 1.000 | 1.025 | 1.050 | 1.075 | 1.100 | 1.125 | 1.150 | 1.175 | 1.200 | 1.250 | 1.275 |
| 3.0                           | 0.907 | 0.918 | 0.917 | 0.916 | 0.915 | 0.914 | 0.913 | 0.912 | 0.911 | 0.910 | 0.909 | 0.908 | 0.906 | 0.905 |
| 3.5                           | 0.875 | 0.883 | 0.882 | 0.881 | 0.881 | 0.880 | 0.879 | 0.879 | 0.878 | 0.877 | 0.876 | 0.876 | 0.874 | 0.873 |
| 4.0                           | 0.848 | 0.858 | 0.857 | 0.856 | 0.855 | 0.854 | 0.853 | 0.852 | 0.851 | 0.850 | 0.849 | 0.849 | 0.847 | 0.847 |
| 4.5                           | 0.832 | 0.833 | 0.833 | 0.833 | 0.833 | 0.833 | 0.833 | 0.833 | 0.833 | 0.833 | 0.832 | 0.832 | 0.832 | 0.831 |
| 5.0                           | 0.836 | 0.840 | 0.840 | 0.839 | 0.839 | 0.839 | 0.838 | 0.838 | 0.838 | 0.837 | 0.837 | 0.837 | 0.836 | 0.835 |
| 5.5                           | 0.804 | 0.809 | 0.809 | 0.808 | 0.808 | 0.807 | 0.807 | 0.806 | 0.806 | 0.805 | 0.805 | 0.804 | 0.803 | 0.803 |
| 6.0                           | 0.749 | 0.755 | 0.755 | 0.754 | 0.754 | 0.753 | 0.752 | 0.752 | 0.751 | 0.751 | 0.750 | 0.750 | 0.749 | 0.748 |
| 6.5                           | 0.694 | 0.700 | 0.700 | 0.699 | 0.699 | 0.698 | 0.697 | 0.697 | 0.696 | 0.696 | 0.695 | 0.695 | 0.694 | 0.693 |
| 7.0                           | 0.632 | 0.637 | 0.637 | 0.636 | 0.636 | 0.635 | 0.635 | 0.634 | 0.634 | 0.633 | 0.633 | 0.632 | 0.631 | 0.631 |
| 7.5                           | 0.557 | 0.561 | 0.561 | 0.560 | 0.560 | 0.559 | 0.559 | 0.559 | 0.558 | 0.558 | 0.557 | 0.557 | 0.556 | 0.556 |
| 8.0                           | 0.491 | 0.495 | 0.495 | 0.495 | 0.494 | 0.494 | 0.493 | 0.493 | 0.492 | 0.492 | 0.491 | 0.491 | 0.490 | 0.490 |
| 8.5                           | 0.459 | 0.477 | 0.476 | 0.474 | 0.473 | 0.472 | 0.470 | 0.468 | 0.466 | 0.465 | 0.463 | 0.461 | 0.457 | 0.454 |
| 9.0                           | 0.446 | 0.521 | 0.514 | 0.507 | 0.499 | 0.492 | 0.485 | 0.479 | 0.472 | 0.465 | 0.459 | 0.452 | 0.440 | 0.434 |
| 9.5                           | 0.412 | 0.529 | 0.518 | 0.506 | 0.494 | 0.483 | 0.472 | 0.462 | 0.451 | 0.440 | 0.431 | 0.421 | 0.404 | 0.395 |
| 10.0                          | 0.358 | 0.484 | 0.471 | 0.457 | 0.443 | 0.430 | 0.419 | 0.408 | 0.396 | 0.385 | 0.376 | 0.367 | 0.350 | 0.343 |
| 10.5                          | 0.309 | 0.415 | 0.403 | 0.391 | 0.379 | 0.367 | 0.358 | 0.349 | 0.340 | 0.331 | 0.324 | 0.316 | 0.302 | 0.296 |
| 11.0                          | 0.269 | 0.357 | 0.347 | 0.337 | 0.328 | 0.318 | 0.310 | 0.303 | 0.295 | 0.288 | 0.282 | 0.275 | 0.264 | 0.258 |
| 11.5                          | 0.236 | 0.310 | 0.302 | 0.294 | 0.286 | 0.278 | 0.271 | 0.265 | 0.258 | 0.252 | 0.247 | 0.241 | 0.231 | 0.226 |
| 12.0                          | 0.208 | 0.272 | 0.265 | 0.258 | 0.251 | 0.244 | 0.239 | 0.233 | 0.228 | 0.222 | 0.217 | 0.213 | 0.204 | 0.200 |
| 12.5                          | 0.185 | 0.240 | 0.234 | 0.228 | 0.222 | 0.216 | 0.212 | 0.207 | 0.202 | 0.197 | 0.193 | 0.189 | 0.182 | 0.178 |
| 13.0                          | 0.166 | 0.215 | 0.210 | 0.205 | 0.199 | 0.194 | 0.190 | 0.186 | 0.181 | 0.177 | 0.173 | 0.170 | 0.163 | 0.160 |
| 13.5                          | 0.152 | 0.196 | 0.192 | 0.187 | 0.182 | 0.177 | 0.173 | 0.170 | 0.166 | 0.162 | 0.159 | 0.155 | 0.149 | 0.146 |
| 14.0                          | 0.139 | 0.179 | 0.175 | 0.171 | 0.166 | 0.162 | 0.159 | 0.155 | 0.152 | 0.148 | 0.145 | 0.142 | 0.137 | 0.134 |
| 14.5                          | 0.128 | 0.165 | 0.161 | 0.157 | 0.153 | 0.149 | 0.146 | 0.143 | 0.139 | 0.136 | 0.134 | 0.131 | 0.126 | 0.123 |
| 15.0                          | 0.118 | 0.151 | 0.148 | 0.144 | 0.141 | 0.137 | 0.134 | 0.131 | 0.128 | 0.125 | 0.123 | 0.120 | 0.116 | 0.114 |
| 15.5                          | 0.109 | 0.140 | 0.137 | 0.133 | 0.130 | 0.127 | 0.124 | 0.122 | 0.119 | 0.116 | 0.114 | 0.112 | 0.107 | 0.105 |
| 16.0                          | 0.102 | 0.130 | 0.127 | 0.124 | 0.121 | 0.118 | 0.115 | 0.113 | 0.110 | 0.108 | 0.106 | 0.104 | 0.100 | 0.098 |
| 16.5                          | 0.095 | 0.121 | 0.118 | 0.115 | 0.112 | 0.110 | 0.107 | 0.105 | 0.103 | 0.101 | 0.099 | 0.097 | 0.093 | 0.091 |
| 17.0                          | 0.088 | 0.113 | 0.110 | 0.107 | 0.105 | 0.102 | 0.100 | 0.098 | 0.096 | 0.094 | 0.092 | 0.090 | 0.087 | 0.085 |
| 17.5                          | 0.083 | 0.105 | 0.103 | 0.100 | 0.098 | 0.095 | 0.093 | 0.091 | 0.089 | 0.088 | 0.086 | 0.084 | 0.081 | 0.080 |
| 18.0                          | 0.077 | 0.098 | 0.096 | 0.094 | 0.092 | 0.089 | 0.087 | 0.086 | 0.084 | 0.082 | 0.081 | 0.079 | 0.076 | 0.075 |
| 18.5                          | 0.073 | 0.092 | 0.090 | 0.088 | 0.086 | 0.084 | 0.082 | 0.081 | 0.079 | 0.077 | 0.076 | 0.074 | 0.072 | 0.070 |
| 19.0                          | 0.068 | 0.086 | 0.084 | 0.082 | 0.081 | 0.079 | 0.077 | 0.075 | 0.074 | 0.072 | 0.071 | 0.070 | 0.067 | 0.066 |
| 19.5                          | 0.065 | 0.081 | 0.080 | 0.078 | 0.076 | 0.074 | 0.073 | 0.071 | 0.070 | 0.068 | 0.067 | 0.066 | 0.063 | 0.062 |
| 20.0                          | 0.061 | 0.077 | 0.075 | 0.073 | 0.072 | 0.070 | 0.069 | 0.067 | 0.066 | 0.065 | 0.063 | 0.062 | 0.060 | 0.059 |
| 20.5                          | 0.058 | 0.073 | 0.071 | 0.069 | 0.068 | 0.066 | 0.065 | 0.064 | 0.062 | 0.061 | 0.060 | 0.059 | 0.057 | 0.056 |
| 21.0                          | 0.055 | 0.069 | 0.067 | 0.066 | 0.064 | 0.063 | 0.062 | 0.060 | 0.059 | 0.058 | 0.057 | 0.056 | 0.054 | 0.053 |
| 21.5                          | 0.053 | 0.066 | 0.064 | 0.063 | 0.061 | 0.060 | 0.059 | 0.058 | 0.057 | 0.055 | 0.054 | 0.053 | 0.052 | 0.051 |
| 22.0                          | 0.050 | 0.062 | 0.061 | 0.060 | 0.058 | 0.057 | 0.056 | 0.055 | 0.054 | 0.053 | 0.052 | 0.051 | 0.049 | 0.048 |
| 22.5                          | 0.047 | 0.059 | 0.058 | 0.057 | 0.055 | 0.054 | 0.053 | 0.052 | 0.051 | 0.050 | 0.049 | 0.048 | 0.047 | 0.046 |
| 23.0                          | 0.045 | 0.056 | 0.054 | 0.053 | 0.052 | 0.051 | 0.050 | 0.049 | 0.048 | 0.047 | 0.046 | 0.046 | 0.044 | 0.043 |
| 23.5                          | 0.043 | 0.053 | 0.052 | 0.051 | 0.049 | 0.048 | 0.048 | 0.047 | 0.046 | 0.045 | 0.044 | 0.043 | 0.042 | 0.041 |
| 24.0                          | 0.041 | 0.050 | 0.049 | 0.048 | 0.047 | 0.046 | 0.045 | 0.044 | 0.043 | 0.043 | 0.042 | 0.041 | 0.040 | 0.039 |
| 24.5                          | 0.039 | 0.047 | 0.046 | 0.046 | 0.045 | 0.044 | 0.043 | 0.042 | 0.041 | 0.041 | 0.040 | 0.039 | 0.038 | 0.037 |
| 25.0                          | 0.037 | 0.045 | 0.044 | 0.043 | 0.042 | 0.041 | 0.041 | 0.040 | 0.039 | 0.039 | 0.038 | 0.037 | 0.036 | 0.036 |
| 25.5                          | 0.035 | 0.043 | 0.042 | 0.041 | 0.040 | 0.040 | 0.039 | 0.038 | 0.038 | 0.037 | 0.036 | 0.036 | 0.035 | 0.034 |
| 26.0                          | 0.034 | 0.041 | 0.040 | 0.039 | 0.038 | 0.038 | 0.037 | 0.036 | 0.036 | 0.035 | 0.035 | 0.034 | 0.033 | 0.033 |
| 26.5                          | 0.032 | 0.039 | 0.038 | 0.037 | 0.037 | 0.036 | 0.035 | 0.035 | 0.034 | 0.033 | 0.033 | 0.032 | 0.032 | 0.031 |
| 27.0                          | 0.031 | 0.037 | 0.036 | 0.036 | 0.035 | 0.034 | 0.034 | 0.033 | 0.033 | 0.032 | 0.032 | 0.031 | 0.030 | 0.030 |

Table 16-2: C<sub>t</sub> values, Sound Optimized Mode SO12

### 16.3 Sound Curves, Sound Optimized Mode SO12

| Sound Power Level at Hub Height   |  |
|-----------------------------------|--|
| Conditions for Sound Power Level: | Measurement standard IEC 61400-11 ed. 3<br>Maximum turbulence at hub height: 30%<br>Inflow angle (vertical): 0 ±2°<br>Air density: 1.225 kg/m <sup>3</sup> |
| Wind speed at hub height [m/s]    | Sound Power Level at Hub Height [dBA]<br>Sound Optimized Mode SO12<br>(Blades with serrated trailing edge)   |
| 3                                 | 92.1   |
| 4                                 | 92.4   |
| 5                                 | 93.0   |
| 6                                 | 94.9   |
| 7                                 | 97.1   |
| 8                                 | 98.8   |
| 9                                 | 99.7   |
| 10                                | 99.9   |
| 11                                | 99.9   |
| 12                                | 99.9   |
| 13                                | 99.9   |
| 14                                | 99.9   |
| 15                                | 99.9   |
| 16                                | 99.9   |
| 17                                | 99.9   |
| 18                                | 99.9   |
| 19                                | 99.9   |
| 20                                | 99.9   |

*Table 16-3: Sound curves, Sound Optimized Mode SO12*

**17 Power Curves, Ct Values and Sound Curves, Sound Optimized Mode SO12 (HWO)**

**NOTE** The power curves and Ct values presented in Section 17 are only valid for low hub heights, i.e. hub heights ≤ 104 m.

**17.1 Power Curves, Sound Optimized Mode SO12 (HWO)**

| Wind speed [m/s] | Air density [kg/m <sup>3</sup> ] |       |       |       |       |       |       |       |       |       |       |       |       |       |
|------------------|----------------------------------|-------|-------|-------|-------|-------|-------|-------|-------|-------|-------|-------|-------|-------|
|                  | 1.225                            | 0.950 | 0.975 | 1.000 | 1.025 | 1.050 | 1.075 | 1.100 | 1.125 | 1.150 | 1.175 | 1.200 | 1.250 | 1.275 |
| 3.0              | 19                               | 7     | 8     | 9     | 10    | 11    | 12    | 13    | 14    | 15    | 16    | 17    | 20    | 21    |
| 3.5              | 96                               | 61    | 64    | 67    | 70    | 73    | 77    | 80    | 83    | 86    | 89    | 93    | 99    | 102   |
| 4.0              | 198                              | 141   | 146   | 151   | 157   | 162   | 167   | 172   | 177   | 183   | 188   | 193   | 203   | 209   |
| 4.5              | 323                              | 238   | 246   | 254   | 261   | 269   | 277   | 284   | 292   | 300   | 308   | 315   | 331   | 338   |
| 5.0              | 470                              | 352   | 363   | 374   | 384   | 395   | 406   | 416   | 427   | 438   | 448   | 459   | 480   | 491   |
| 5.5              | 637                              | 483   | 497   | 511   | 525   | 539   | 553   | 567   | 581   | 595   | 609   | 623   | 651   | 665   |
| 6.0              | 830                              | 633   | 651   | 669   | 687   | 705   | 723   | 741   | 759   | 777   | 794   | 812   | 848   | 865   |
| 6.5              | 1037                             | 796   | 818   | 840   | 862   | 884   | 906   | 928   | 950   | 972   | 994   | 1016  | 1059  | 1081  |
| 7.0              | 1244                             | 958   | 984   | 1010  | 1036  | 1063  | 1089  | 1115  | 1141  | 1167  | 1192  | 1218  | 1270  | 1295  |
| 7.5              | 1414                             | 1092  | 1121  | 1151  | 1180  | 1210  | 1239  | 1269  | 1298  | 1327  | 1356  | 1385  | 1444  | 1472  |
| 8.0              | 1573                             | 1218  | 1250  | 1283  | 1315  | 1348  | 1380  | 1412  | 1445  | 1477  | 1509  | 1541  | 1605  | 1636  |
| 8.5              | 1805                             | 1434  | 1469  | 1505  | 1541  | 1576  | 1610  | 1644  | 1677  | 1711  | 1742  | 1774  | 1835  | 1865  |
| 9.0              | 2100                             | 1817  | 1848  | 1880  | 1911  | 1942  | 1967  | 1991  | 2015  | 2040  | 2060  | 2080  | 2118  | 2136  |
| 9.5              | 2301                             | 2145  | 2167  | 2190  | 2212  | 2234  | 2246  | 2257  | 2269  | 2280  | 2287  | 2294  | 2307  | 2312  |
| 10.0             | 2382                             | 2331  | 2341  | 2350  | 2360  | 2370  | 2373  | 2375  | 2377  | 2379  | 2380  | 2381  | 2383  | 2383  |
| 10.5             | 2422                             | 2407  | 2409  | 2412  | 2415  | 2417  | 2418  | 2419  | 2420  | 2421  | 2421  | 2422  | 2423  | 2423  |
| 11.0             | 2458                             | 2450  | 2452  | 2453  | 2454  | 2455  | 2456  | 2456  | 2457  | 2457  | 2458  | 2458  | 2458  | 2458  |
| 11.5             | 2486                             | 2483  | 2483  | 2484  | 2484  | 2485  | 2485  | 2485  | 2486  | 2486  | 2486  | 2486  | 2486  | 2486  |
| 12.0             | 2510                             | 2509  | 2509  | 2509  | 2509  | 2510  | 2510  | 2510  | 2510  | 2510  | 2510  | 2510  | 2509  | 2509  |
| 12.5             | 2534                             | 2535  | 2535  | 2535  | 2535  | 2535  | 2535  | 2535  | 2535  | 2534  | 2534  | 2534  | 2534  | 2533  |
| 13.0             | 2567                             | 2570  | 2570  | 2570  | 2570  | 2570  | 2570  | 2569  | 2569  | 2568  | 2568  | 2568  | 2567  | 2566  |
| 13.5             | 2621                             | 2626  | 2625  | 2625  | 2625  | 2625  | 2624  | 2624  | 2623  | 2623  | 2622  | 2621  | 2620  | 2619  |
| 14.0             | 2679                             | 2685  | 2684  | 2684  | 2684  | 2684  | 2683  | 2682  | 2682  | 2681  | 2680  | 2680  | 2678  | 2677  |
| 14.5             | 2740                             | 2746  | 2746  | 2746  | 2745  | 2745  | 2744  | 2744  | 2743  | 2742  | 2741  | 2741  | 2739  | 2738  |
| 15.0             | 2803                             | 2810  | 2810  | 2809  | 2809  | 2808  | 2808  | 2807  | 2806  | 2805  | 2804  | 2804  | 2802  | 2800  |
| 15.5             | 2863                             | 2872  | 2871  | 2871  | 2870  | 2870  | 2869  | 2868  | 2867  | 2866  | 2865  | 2864  | 2862  | 2861  |
| 16.0             | 2922                             | 2931  | 2931  | 2930  | 2930  | 2929  | 2928  | 2927  | 2927  | 2926  | 2925  | 2924  | 2921  | 2920  |
| 16.5             | 2978                             | 2987  | 2986  | 2986  | 2986  | 2985  | 2984  | 2983  | 2982  | 2981  | 2980  | 2979  | 2977  | 2976  |
| 17.0             | 3030                             | 3040  | 3039  | 3038  | 3038  | 3037  | 3036  | 3035  | 3035  | 3034  | 3033  | 3032  | 3029  | 3028  |
| 17.5             | 3081                             | 3090  | 3090  | 3089  | 3088  | 3088  | 3087  | 3086  | 3085  | 3084  | 3083  | 3082  | 3080  | 3078  |
| 18.0             | 3131                             | 3141  | 3141  | 3140  | 3139  | 3138  | 3137  | 3136  | 3135  | 3134  | 3133  | 3132  | 3129  | 3128  |
| 18.5             | 3182                             | 3194  | 3193  | 3192  | 3192  | 3191  | 3190  | 3189  | 3187  | 3186  | 3185  | 3184  | 3181  | 3180  |
| 19.0             | 3236                             | 3249  | 3248  | 3247  | 3246  | 3245  | 3244  | 3243  | 3241  | 3240  | 3239  | 3238  | 3235  | 3234  |
| 19.5             | 3290                             | 3302  | 3301  | 3300  | 3299  | 3298  | 3297  | 3296  | 3295  | 3294  | 3292  | 3291  | 3288  | 3286  |
| 20.0             | 3339                             | 3351  | 3350  | 3349  | 3348  | 3348  | 3346  | 3345  | 3344  | 3343  | 3342  | 3340  | 3338  | 3336  |
| 20.5             | 3384                             | 3396  | 3395  | 3394  | 3393  | 3392  | 3391  | 3390  | 3389  | 3388  | 3387  | 3386  | 3383  | 3382  |
| 21.0             | 3428                             | 3439  | 3438  | 3437  | 3436  | 3436  | 3435  | 3433  | 3432  | 3431  | 3430  | 3429  | 3426  | 3425  |
| 21.5             | 3470                             | 3481  | 3480  | 3479  | 3478  | 3478  | 3476  | 3475  | 3474  | 3473  | 3472  | 3471  | 3468  | 3467  |
| 22.0             | 3510                             | 3522  | 3521  | 3520  | 3519  | 3518  | 3517  | 3516  | 3515  | 3514  | 3513  | 3512  | 3509  | 3508  |
| 22.5             | 3547                             | 3557  | 3556  | 3555  | 3554  | 3553  | 3552  | 3552  | 3551  | 3550  | 3549  | 3548  | 3546  | 3544  |
| 23.0             | 3574                             | 3582  | 3582  | 3581  | 3581  | 3580  | 3579  | 3579  | 3578  | 3577  | 3576  | 3575  | 3574  | 3573  |
| 23.5             | 3598                             | 3603  | 3603  | 3602  | 3602  | 3602  | 3601  | 3601  | 3600  | 3599  | 3599  | 3598  | 3597  | 3596  |
| 24.0             | 3614                             | 3618  | 3618  | 3617  | 3617  | 3616  | 3616  | 3616  | 3615  | 3615  | 3615  | 3614  | 3613  | 3613  |
| 24.5             | 3624                             | 3626  | 3626  | 3626  | 3626  | 3626  | 3625  | 3625  | 3625  | 3625  | 3625  | 3624  | 3624  | 3624  |
| 25.0             | 3630                             | 3632  | 3632  | 3631  | 3631  | 3631  | 3631  | 3631  | 3631  | 3631  | 3630  | 3630  | 3630  | 3630  |
| 25.5             | 3634                             | 3634  | 3634  | 3634  | 3634  | 3634  | 3634  | 3634  | 3634  | 3634  | 3634  | 3634  | 3634  | 3634  |
| 26.0             | 3634                             | 3634  | 3634  | 3634  | 3634  | 3634  | 3634  | 3634  | 3634  | 3634  | 3634  | 3634  | 3634  | 3634  |
| 26.5             | 3628                             | 3628  | 3628  | 3628  | 3628  | 3628  | 3628  | 3628  | 3628  | 3628  | 3628  | 3628  | 3628  | 3628  |
| 27.0             | 3617                             | 3617  | 3617  | 3617  | 3617  | 3617  | 3617  | 3617  | 3617  | 3617  | 3617  | 3617  | 3617  | 3617  |
| 27.5             | 3558                             | 3558  | 3558  | 3558  | 3558  | 3558  | 3558  | 3558  | 3558  | 3558  | 3558  | 3558  | 3558  | 3558  |
| 28.0             | 3440                             | 3440  | 3440  | 3440  | 3440  | 3440  | 3440  | 3440  | 3440  | 3440  | 3440  | 3440  | 3440  | 3440  |

| <b>Air density [kg/m<sup>3</sup>]</b> |              |              |              |              |              |              |              |              |              |              |              |              |              |              |
|---------------------------------------|--------------|--------------|--------------|--------------|--------------|--------------|--------------|--------------|--------------|--------------|--------------|--------------|--------------|--------------|
| <b>Wind speed [m/s]</b>               | <b>1.225</b> | <b>0.950</b> | <b>0.975</b> | <b>1.000</b> | <b>1.025</b> | <b>1.050</b> | <b>1.075</b> | <b>1.100</b> | <b>1.125</b> | <b>1.150</b> | <b>1.175</b> | <b>1.200</b> | <b>1.250</b> | <b>1.275</b> |
| <b>28.5</b>                           | <b>3258</b>  | 3258         | 3258         | 3258         | 3258         | 3258         | 3258         | 3258         | 3258         | 3258         | 3258         | 3258         | 3258         | 3258         |
| <b>29.0</b>                           | <b>3033</b>  | 3033         | 3033         | 3033         | 3033         | 3033         | 3033         | 3033         | 3033         | 3033         | 3033         | 3033         | 3033         | 3033         |
| <b>29.5</b>                           | <b>2789</b>  | 2789         | 2789         | 2789         | 2789         | 2789         | 2789         | 2789         | 2789         | 2789         | 2789         | 2789         | 2789         | 2789         |
| <b>30.0</b>                           | <b>2548</b>  | 2548         | 2548         | 2548         | 2548         | 2548         | 2548         | 2548         | 2548         | 2548         | 2548         | 2548         | 2548         | 2548         |
| <b>30.5</b>                           | <b>2308</b>  | 2308         | 2308         | 2308         | 2308         | 2308         | 2308         | 2308         | 2308         | 2308         | 2308         | 2308         | 2308         | 2308         |
| <b>31.0</b>                           | <b>2072</b>  | 2073         | 2073         | 2073         | 2073         | 2073         | 2073         | 2073         | 2073         | 2073         | 2073         | 2073         | 2073         | 2072         |
| <b>31.5</b>                           | <b>1868</b>  | 1868         | 1868         | 1868         | 1868         | 1868         | 1868         | 1868         | 1868         | 1868         | 1868         | 1868         | 1868         | 1868         |
| <b>32.0</b>                           | <b>1721</b>  | 1721         | 1721         | 1721         | 1721         | 1721         | 1721         | 1721         | 1721         | 1721         | 1721         | 1721         | 1721         | 1721         |

*Table 17-1: Power curve, Sound Optimized Mode SO12 (HWO)*

**17.2 Ct Values, Sound Optimized Mode SO12 (HWO)**

| Air density kg/m <sup>3</sup> |       |       |       |       |       |       |       |       |       |       |       |       |       |       |
|-------------------------------|-------|-------|-------|-------|-------|-------|-------|-------|-------|-------|-------|-------|-------|-------|
| Wind speed [m/s]              | 1.225 | 0.950 | 0.975 | 1.000 | 1.025 | 1.050 | 1.075 | 1.100 | 1.125 | 1.150 | 1.175 | 1.200 | 1.250 | 1.275 |
| 3.0                           | 0.907 | 0.918 | 0.917 | 0.916 | 0.915 | 0.914 | 0.913 | 0.912 | 0.911 | 0.910 | 0.909 | 0.908 | 0.906 | 0.905 |
| 3.5                           | 0.875 | 0.883 | 0.882 | 0.881 | 0.881 | 0.880 | 0.879 | 0.879 | 0.878 | 0.877 | 0.876 | 0.876 | 0.874 | 0.873 |
| 4.0                           | 0.848 | 0.858 | 0.857 | 0.856 | 0.855 | 0.854 | 0.853 | 0.852 | 0.851 | 0.850 | 0.849 | 0.849 | 0.847 | 0.847 |
| 4.5                           | 0.832 | 0.833 | 0.833 | 0.833 | 0.833 | 0.833 | 0.833 | 0.833 | 0.833 | 0.833 | 0.832 | 0.832 | 0.832 | 0.831 |
| 5.0                           | 0.836 | 0.840 | 0.840 | 0.839 | 0.839 | 0.839 | 0.838 | 0.838 | 0.838 | 0.837 | 0.837 | 0.837 | 0.836 | 0.835 |
| 5.5                           | 0.804 | 0.809 | 0.809 | 0.808 | 0.808 | 0.807 | 0.807 | 0.806 | 0.806 | 0.805 | 0.805 | 0.804 | 0.803 | 0.803 |
| 6.0                           | 0.749 | 0.755 | 0.755 | 0.754 | 0.754 | 0.753 | 0.752 | 0.752 | 0.751 | 0.751 | 0.750 | 0.750 | 0.749 | 0.748 |
| 6.5                           | 0.694 | 0.700 | 0.700 | 0.699 | 0.699 | 0.698 | 0.697 | 0.697 | 0.696 | 0.696 | 0.695 | 0.695 | 0.694 | 0.693 |
| 7.0                           | 0.632 | 0.637 | 0.637 | 0.636 | 0.636 | 0.635 | 0.635 | 0.634 | 0.634 | 0.633 | 0.633 | 0.632 | 0.631 | 0.631 |
| 7.5                           | 0.557 | 0.561 | 0.561 | 0.560 | 0.560 | 0.559 | 0.559 | 0.559 | 0.558 | 0.558 | 0.557 | 0.557 | 0.556 | 0.556 |
| 8.0                           | 0.491 | 0.495 | 0.495 | 0.495 | 0.494 | 0.494 | 0.493 | 0.493 | 0.492 | 0.492 | 0.491 | 0.491 | 0.490 | 0.490 |
| 8.5                           | 0.459 | 0.477 | 0.476 | 0.474 | 0.473 | 0.472 | 0.470 | 0.468 | 0.466 | 0.465 | 0.463 | 0.461 | 0.457 | 0.454 |
| 9.0                           | 0.446 | 0.521 | 0.514 | 0.507 | 0.499 | 0.492 | 0.485 | 0.479 | 0.472 | 0.465 | 0.459 | 0.452 | 0.440 | 0.434 |
| 9.5                           | 0.412 | 0.529 | 0.518 | 0.506 | 0.494 | 0.483 | 0.472 | 0.462 | 0.451 | 0.440 | 0.431 | 0.421 | 0.404 | 0.395 |
| 10.0                          | 0.358 | 0.484 | 0.471 | 0.457 | 0.443 | 0.430 | 0.419 | 0.408 | 0.396 | 0.385 | 0.376 | 0.367 | 0.350 | 0.343 |
| 10.5                          | 0.309 | 0.415 | 0.403 | 0.391 | 0.379 | 0.367 | 0.358 | 0.349 | 0.340 | 0.331 | 0.324 | 0.316 | 0.302 | 0.296 |
| 11.0                          | 0.269 | 0.357 | 0.347 | 0.337 | 0.328 | 0.318 | 0.310 | 0.303 | 0.295 | 0.288 | 0.282 | 0.275 | 0.264 | 0.258 |
| 11.5                          | 0.236 | 0.310 | 0.302 | 0.294 | 0.286 | 0.278 | 0.271 | 0.265 | 0.258 | 0.252 | 0.247 | 0.241 | 0.231 | 0.226 |
| 12.0                          | 0.208 | 0.272 | 0.265 | 0.258 | 0.251 | 0.244 | 0.239 | 0.233 | 0.228 | 0.222 | 0.217 | 0.213 | 0.204 | 0.200 |
| 12.5                          | 0.185 | 0.240 | 0.234 | 0.228 | 0.222 | 0.216 | 0.212 | 0.207 | 0.202 | 0.197 | 0.193 | 0.189 | 0.182 | 0.178 |
| 13.0                          | 0.166 | 0.215 | 0.210 | 0.205 | 0.199 | 0.194 | 0.190 | 0.186 | 0.181 | 0.177 | 0.173 | 0.170 | 0.163 | 0.160 |
| 13.5                          | 0.152 | 0.196 | 0.192 | 0.187 | 0.182 | 0.177 | 0.173 | 0.170 | 0.166 | 0.162 | 0.159 | 0.155 | 0.149 | 0.146 |
| 14.0                          | 0.139 | 0.179 | 0.175 | 0.171 | 0.166 | 0.162 | 0.159 | 0.155 | 0.152 | 0.148 | 0.145 | 0.142 | 0.137 | 0.134 |
| 14.5                          | 0.128 | 0.165 | 0.161 | 0.157 | 0.153 | 0.149 | 0.146 | 0.143 | 0.139 | 0.136 | 0.134 | 0.131 | 0.126 | 0.123 |
| 15.0                          | 0.118 | 0.151 | 0.148 | 0.144 | 0.141 | 0.137 | 0.134 | 0.131 | 0.128 | 0.125 | 0.123 | 0.120 | 0.116 | 0.114 |
| 15.5                          | 0.109 | 0.140 | 0.137 | 0.133 | 0.130 | 0.127 | 0.124 | 0.122 | 0.119 | 0.116 | 0.114 | 0.112 | 0.107 | 0.105 |
| 16.0                          | 0.102 | 0.130 | 0.127 | 0.124 | 0.121 | 0.118 | 0.115 | 0.113 | 0.110 | 0.108 | 0.106 | 0.104 | 0.100 | 0.098 |
| 16.5                          | 0.095 | 0.121 | 0.118 | 0.115 | 0.112 | 0.110 | 0.107 | 0.105 | 0.103 | 0.101 | 0.099 | 0.097 | 0.093 | 0.091 |
| 17.0                          | 0.088 | 0.113 | 0.110 | 0.107 | 0.105 | 0.102 | 0.100 | 0.098 | 0.096 | 0.094 | 0.092 | 0.090 | 0.087 | 0.085 |
| 17.5                          | 0.083 | 0.105 | 0.103 | 0.100 | 0.098 | 0.095 | 0.093 | 0.091 | 0.089 | 0.088 | 0.086 | 0.084 | 0.081 | 0.080 |
| 18.0                          | 0.077 | 0.098 | 0.096 | 0.094 | 0.092 | 0.089 | 0.087 | 0.086 | 0.084 | 0.082 | 0.081 | 0.079 | 0.076 | 0.075 |
| 18.5                          | 0.073 | 0.092 | 0.090 | 0.088 | 0.086 | 0.084 | 0.082 | 0.081 | 0.079 | 0.077 | 0.076 | 0.074 | 0.072 | 0.070 |
| 19.0                          | 0.068 | 0.086 | 0.084 | 0.082 | 0.081 | 0.079 | 0.077 | 0.075 | 0.074 | 0.072 | 0.071 | 0.070 | 0.067 | 0.066 |
| 19.5                          | 0.065 | 0.081 | 0.080 | 0.078 | 0.076 | 0.074 | 0.073 | 0.071 | 0.070 | 0.068 | 0.067 | 0.066 | 0.063 | 0.062 |
| 20.0                          | 0.061 | 0.077 | 0.075 | 0.073 | 0.072 | 0.070 | 0.069 | 0.067 | 0.066 | 0.065 | 0.063 | 0.062 | 0.060 | 0.059 |
| 20.5                          | 0.058 | 0.073 | 0.071 | 0.069 | 0.068 | 0.066 | 0.065 | 0.064 | 0.062 | 0.061 | 0.060 | 0.059 | 0.057 | 0.056 |
| 21.0                          | 0.055 | 0.069 | 0.067 | 0.066 | 0.064 | 0.063 | 0.062 | 0.060 | 0.059 | 0.058 | 0.057 | 0.056 | 0.054 | 0.053 |
| 21.5                          | 0.053 | 0.066 | 0.064 | 0.063 | 0.061 | 0.060 | 0.059 | 0.058 | 0.057 | 0.055 | 0.054 | 0.053 | 0.052 | 0.051 |
| 22.0                          | 0.050 | 0.062 | 0.061 | 0.060 | 0.058 | 0.057 | 0.056 | 0.055 | 0.054 | 0.053 | 0.052 | 0.051 | 0.049 | 0.048 |
| 22.5                          | 0.047 | 0.059 | 0.058 | 0.057 | 0.055 | 0.054 | 0.053 | 0.052 | 0.051 | 0.050 | 0.049 | 0.048 | 0.047 | 0.046 |
| 23.0                          | 0.045 | 0.056 | 0.054 | 0.053 | 0.052 | 0.051 | 0.050 | 0.049 | 0.048 | 0.047 | 0.046 | 0.046 | 0.044 | 0.043 |
| 23.5                          | 0.043 | 0.053 | 0.052 | 0.051 | 0.049 | 0.048 | 0.048 | 0.047 | 0.046 | 0.045 | 0.044 | 0.043 | 0.042 | 0.041 |
| 24.0                          | 0.041 | 0.050 | 0.049 | 0.048 | 0.047 | 0.046 | 0.045 | 0.044 | 0.043 | 0.043 | 0.042 | 0.041 | 0.040 | 0.039 |
| 24.5                          | 0.039 | 0.047 | 0.046 | 0.046 | 0.045 | 0.044 | 0.043 | 0.042 | 0.041 | 0.041 | 0.040 | 0.039 | 0.038 | 0.037 |
| 25.0                          | 0.037 | 0.045 | 0.044 | 0.043 | 0.042 | 0.041 | 0.041 | 0.040 | 0.039 | 0.039 | 0.038 | 0.037 | 0.036 | 0.036 |
| 25.5                          | 0.035 | 0.043 | 0.042 | 0.041 | 0.040 | 0.040 | 0.039 | 0.038 | 0.038 | 0.037 | 0.036 | 0.036 | 0.035 | 0.034 |
| 26.0                          | 0.033 | 0.041 | 0.040 | 0.039 | 0.038 | 0.038 | 0.037 | 0.036 | 0.036 | 0.035 | 0.035 | 0.034 | 0.033 | 0.032 |
| 26.5                          | 0.032 | 0.039 | 0.038 | 0.037 | 0.036 | 0.036 | 0.035 | 0.034 | 0.034 | 0.033 | 0.033 | 0.032 | 0.031 | 0.031 |
| 27.0                          | 0.030 | 0.037 | 0.036 | 0.035 | 0.035 | 0.034 | 0.033 | 0.033 | 0.032 | 0.032 | 0.031 | 0.031 | 0.030 | 0.029 |
| 27.5                          | 0.028 | 0.034 | 0.034 | 0.033 | 0.032 | 0.032 | 0.031 | 0.031 | 0.030 | 0.030 | 0.029 | 0.029 | 0.028 | 0.027 |
| 28.0                          | 0.026 | 0.032 | 0.031 | 0.031 | 0.030 | 0.029 | 0.029 | 0.028 | 0.028 | 0.027 | 0.027 | 0.027 | 0.026 | 0.025 |
| 28.5                          | 0.024 | 0.029 | 0.028 | 0.028 | 0.027 | 0.027 | 0.026 | 0.026 | 0.025 | 0.025 | 0.024 | 0.024 | 0.023 | 0.023 |
| 29.0                          | 0.021 | 0.026 | 0.025 | 0.025 | 0.024 | 0.024 | 0.023 | 0.023 | 0.023 | 0.022 | 0.022 | 0.022 | 0.021 | 0.021 |
| 29.5                          | 0.019 | 0.023 | 0.022 | 0.022 | 0.022 | 0.021 | 0.021 | 0.020 | 0.020 | 0.020 | 0.020 | 0.019 | 0.019 | 0.018 |
| 30.0                          | 0.017 | 0.020 | 0.020 | 0.019 | 0.019 | 0.019 | 0.018 | 0.018 | 0.018 | 0.017 | 0.017 | 0.017 | 0.016 | 0.016 |
| 30.5                          | 0.015 | 0.018 | 0.017 | 0.017 | 0.017 | 0.016 | 0.016 | 0.016 | 0.016 | 0.015 | 0.015 | 0.015 | 0.014 | 0.014 |
| 31.0                          | 0.013 | 0.015 | 0.015 | 0.015 | 0.015 | 0.014 | 0.014 | 0.014 | 0.014 | 0.013 | 0.013 | 0.013 | 0.013 | 0.012 |
| 31.5                          | 0.011 | 0.013 | 0.013 | 0.013 | 0.013 | 0.013 | 0.012 | 0.012 | 0.012 | 0.012 | 0.012 | 0.011 | 0.011 | 0.011 |
| 32.0                          | 0.010 | 0.012 | 0.012 | 0.012 | 0.011 | 0.011 | 0.011 | 0.011 | 0.011 | 0.011 | 0.010 | 0.010 | 0.010 | 0.010 |

Table 17-2: C<sub>t</sub> values, Sound Optimized Mode SO12 (HWO)



**17.3 Sound Curves, Sound Optimized Mode SO12 (HWO)**

| <b>Sound Power Level at Hub Height</b>   |  |
|--|--|
| <b>Conditions for Sound Power Level:</b> | Measurement standard IEC 61400-11 ed. 3<br>Maximum turbulence at hub height: 30%<br>Inflow angle (vertical): 0 ±2°<br>Air density: 1.225 kg/m <sup>3</sup> |
| <b>Wind speed at hub height [m/s]</b>    | <b>Sound Power Level at Hub Height [dBA]<br/>Sound Optimized Mode SO12 (HWO)<br/>(Blades with serrated trailing edge)</b>                                  |
| 3  | 92.1   |
| 4  | 92.4   |
| 5  | 93.0   |
| 6  | 94.9   |
| 7  | 97.1   |
| 8  | 98.8   |
| 9  | 99.7   |
| 10                                       | 99.9   |
| 11                                       | 99.9   |
| 12                                       | 99.9   |
| 13                                       | 99.9   |
| 14                                       | 99.9   |
| 15                                       | 99.9   |
| 16                                       | 99.9   |
| 17                                       | 99.9   |
| 18                                       | 99.9   |
| 19                                       | 99.9   |
| 20                                       | 99.9   |

*Table 17-3: Sound curves, Sound Optimized Mode SO12 (HWO)*



**18 Power Curves, Ct Values and Sound Curves, Sound Optimized Mode SO13**

**NOTE** The power curves and Ct values presented in Section 18 are only valid for low hub heights, i.e. hub heights ≤ 104 m.

**18.1 Power Curves, Sound Optimized Mode SO13**

| Air density [kg/m <sup>3</sup> ] |       |       |       |       |       |       |       |       |       |       |       |       |       |       |
|----------------------------------|-------|-------|-------|-------|-------|-------|-------|-------|-------|-------|-------|-------|-------|-------|
| Wind speed [m/s]                 | 1.225 | 0.950 | 0.975 | 1.000 | 1.025 | 1.050 | 1.075 | 1.100 | 1.125 | 1.150 | 1.175 | 1.200 | 1.250 | 1.275 |
| 3.0                              | 19    | 7     | 8     | 9     | 10    | 11    | 12    | 13    | 14    | 15    | 16    | 17    | 20    | 21    |
| 3.5                              | 96    | 61    | 64    | 67    | 70    | 73    | 77    | 80    | 83    | 86    | 89    | 93    | 99    | 102   |
| 4.0                              | 198   | 141   | 146   | 151   | 156   | 162   | 167   | 172   | 177   | 182   | 188   | 193   | 203   | 208   |
| 4.5                              | 317   | 234   | 242   | 249   | 257   | 264   | 272   | 280   | 287   | 295   | 302   | 310   | 325   | 332   |
| 5.0                              | 438   | 329   | 339   | 349   | 359   | 369   | 379   | 389   | 399   | 409   | 418   | 428   | 448   | 458   |
| 5.5                              | 537   | 406   | 418   | 430   | 442   | 453   | 465   | 477   | 489   | 501   | 513   | 525   | 548   | 560   |
| 6.0                              | 641   | 488   | 502   | 516   | 530   | 544   | 558   | 572   | 586   | 600   | 613   | 627   | 655   | 668   |
| 6.5                              | 768   | 588   | 605   | 621   | 637   | 654   | 670   | 687   | 703   | 719   | 736   | 752   | 784   | 800   |
| 7.0                              | 901   | 692   | 711   | 730   | 749   | 768   | 787   | 806   | 825   | 844   | 863   | 882   | 920   | 939   |
| 7.5                              | 1032  | 795   | 816   | 838   | 860   | 881   | 903   | 924   | 946   | 968   | 989   | 1010  | 1053  | 1075  |
| 8.0                              | 1191  | 923   | 947   | 972   | 997   | 1022  | 1046  | 1071  | 1096  | 1120  | 1144  | 1168  | 1213  | 1235  |
| 8.5                              | 1353  | 1057  | 1086  | 1114  | 1143  | 1171  | 1199  | 1226  | 1253  | 1281  | 1305  | 1329  | 1374  | 1395  |
| 9.0                              | 1457  | 1153  | 1184  | 1215  | 1246  | 1276  | 1305  | 1333  | 1361  | 1390  | 1412  | 1435  | 1476  | 1496  |
| 9.5                              | 1532  | 1264  | 1294  | 1324  | 1354  | 1384  | 1408  | 1432  | 1455  | 1479  | 1497  | 1514  | 1545  | 1559  |
| 10.0                             | 1634  | 1437  | 1461  | 1486  | 1510  | 1534  | 1551  | 1568  | 1584  | 1601  | 1612  | 1623  | 1642  | 1650  |
| 10.5                             | 1739  | 1634  | 1649  | 1663  | 1677  | 1692  | 1700  | 1708  | 1716  | 1724  | 1729  | 1734  | 1742  | 1745  |
| 11.0                             | 1809  | 1776  | 1782  | 1787  | 1793  | 1798  | 1800  | 1802  | 1805  | 1807  | 1807  | 1808  | 1809  | 1809  |
| 11.5                             | 1841  | 1839  | 1840  | 1840  | 1840  | 1841  | 1841  | 1841  | 1841  | 1841  | 1841  | 1841  | 1841  | 1841  |
| 12.0                             | 1863  | 1863  | 1863  | 1863  | 1863  | 1863  | 1863  | 1863  | 1863  | 1863  | 1863  | 1863  | 1863  | 1863  |
| 12.5                             | 1882  | 1883  | 1883  | 1882  | 1882  | 1882  | 1882  | 1882  | 1882  | 1882  | 1882  | 1882  | 1882  | 1881  |
| 13.0                             | 1900  | 1902  | 1901  | 1901  | 1901  | 1901  | 1901  | 1901  | 1901  | 1901  | 1901  | 1901  | 1900  | 1900  |
| 13.5                             | 1918  | 1919  | 1919  | 1919  | 1919  | 1919  | 1919  | 1919  | 1918  | 1918  | 1918  | 1918  | 1918  | 1918  |
| 14.0                             | 1934  | 1935  | 1935  | 1935  | 1935  | 1935  | 1935  | 1935  | 1935  | 1935  | 1934  | 1934  | 1934  | 1934  |
| 14.5                             | 1950  | 1952  | 1952  | 1952  | 1951  | 1951  | 1951  | 1951  | 1951  | 1951  | 1951  | 1950  | 1950  | 1950  |
| 15.0                             | 1966  | 1968  | 1968  | 1968  | 1968  | 1968  | 1968  | 1967  | 1967  | 1967  | 1967  | 1967  | 1966  | 1966  |
| 15.5                             | 1982  | 1984  | 1984  | 1984  | 1983  | 1983  | 1983  | 1983  | 1983  | 1983  | 1982  | 1982  | 1982  | 1982  |
| 16.0                             | 1996  | 1998  | 1998  | 1998  | 1998  | 1998  | 1998  | 1997  | 1997  | 1997  | 1997  | 1997  | 1996  | 1996  |
| 16.5                             | 2009  | 2011  | 2011  | 2011  | 2011  | 2011  | 2010  | 2010  | 2010  | 2010  | 2010  | 2009  | 2009  | 2009  |
| 17.0                             | 2021  | 2022  | 2022  | 2022  | 2022  | 2022  | 2022  | 2022  | 2022  | 2021  | 2021  | 2021  | 2021  | 2020  |
| 17.5                             | 2032  | 2033  | 2033  | 2033  | 2033  | 2033  | 2033  | 2032  | 2032  | 2032  | 2032  | 2032  | 2032  | 2031  |
| 18.0                             | 2042  | 2043  | 2043  | 2043  | 2043  | 2043  | 2042  | 2042  | 2042  | 2042  | 2042  | 2042  | 2041  | 2041  |
| 18.5                             | 2051  | 2052  | 2052  | 2052  | 2052  | 2052  | 2052  | 2052  | 2051  | 2051  | 2051  | 2051  | 2051  | 2050  |
| 19.0                             | 2059  | 2061  | 2061  | 2060  | 2060  | 2060  | 2060  | 2060  | 2060  | 2060  | 2060  | 2059  | 2059  | 2059  |
| 19.5                             | 2067  | 2068  | 2068  | 2068  | 2067  | 2067  | 2067  | 2067  | 2067  | 2067  | 2067  | 2067  | 2066  | 2066  |
| 20.0                             | 2072  | 2073  | 2073  | 2073  | 2073  | 2073  | 2073  | 2073  | 2073  | 2073  | 2073  | 2073  | 2072  | 2072  |
| 20.5                             | 2077  | 2078  | 2078  | 2078  | 2078  | 2078  | 2078  | 2078  | 2078  | 2078  | 2078  | 2077  | 2077  | 2077  |
| 21.0                             | 2083  | 2084  | 2084  | 2084  | 2084  | 2084  | 2084  | 2084  | 2084  | 2084  | 2083  | 2083  | 2083  | 2083  |
| 21.5                             | 2090  | 2092  | 2092  | 2092  | 2091  | 2091  | 2091  | 2091  | 2091  | 2090  | 2090  | 2090  | 2090  | 2090  |
| 22.0                             | 2099  | 2102  | 2102  | 2101  | 2101  | 2101  | 2101  | 2100  | 2100  | 2100  | 2100  | 2099  | 2099  | 2098  |
| 22.5                             | 2110  | 2113  | 2112  | 2112  | 2112  | 2112  | 2111  | 2111  | 2111  | 2111  | 2110  | 2110  | 2109  | 2109  |
| 23.0                             | 2121  | 2124  | 2124  | 2124  | 2124  | 2123  | 2123  | 2123  | 2123  | 2122  | 2122  | 2122  | 2121  | 2121  |
| 23.5                             | 2132  | 2134  | 2134  | 2134  | 2134  | 2134  | 2133  | 2133  | 2133  | 2132  | 2132  | 2132  | 2132  | 2131  |
| 24.0                             | 2140  | 2142  | 2142  | 2142  | 2142  | 2142  | 2141  | 2141  | 2141  | 2141  | 2140  | 2140  | 2140  | 2140  |
| 24.5                             | 2146  | 2148  | 2148  | 2147  | 2147  | 2147  | 2147  | 2147  | 2147  | 2146  | 2146  | 2146  | 2146  | 2146  |
| 25.0                             | 2150  | 2151  | 2151  | 2151  | 2151  | 2151  | 2151  | 2151  | 2151  | 2151  | 2151  | 2151  | 2150  | 2150  |
| 25.5                             | 2153  | 2154  | 2154  | 2154  | 2154  | 2154  | 2154  | 2154  | 2154  | 2154  | 2153  | 2153  | 2153  | 2153  |
| 26.0                             | 2154  | 2154  | 2154  | 2154  | 2154  | 2154  | 2154  | 2154  | 2154  | 2154  | 2154  | 2154  | 2154  | 2154  |
| 26.5                             | 2154  | 2155  | 2155  | 2155  | 2155  | 2154  | 2154  | 2154  | 2154  | 2154  | 2154  | 2154  | 2154  | 2154  |
| 27.0                             | 2154  | 2154  | 2154  | 2154  | 2154  | 2154  | 2154  | 2154  | 2154  | 2154  | 2154  | 2154  | 2155  | 2155  |

Table 18-1: Power curve, Sound Optimized Mode SO13

**18.2 Ct Values, Sound Optimized Mode SO13**

| Air density kg/m <sup>3</sup> |       |       |       |       |       |       |       |       |       |       |       |       |       |       |
|-------------------------------|-------|-------|-------|-------|-------|-------|-------|-------|-------|-------|-------|-------|-------|-------|
| Wind speed [m/s]              | 1.225 | 0.950 | 0.975 | 1.000 | 1.025 | 1.050 | 1.075 | 1.100 | 1.125 | 1.150 | 1.175 | 1.200 | 1.250 | 1.275 |
| 3.0                           | 0.907 | 0.918 | 0.917 | 0.916 | 0.915 | 0.914 | 0.913 | 0.912 | 0.911 | 0.910 | 0.909 | 0.908 | 0.906 | 0.905 |
| 3.5                           | 0.875 | 0.883 | 0.882 | 0.881 | 0.881 | 0.880 | 0.879 | 0.879 | 0.878 | 0.877 | 0.876 | 0.876 | 0.874 | 0.873 |
| 4.0                           | 0.843 | 0.848 | 0.848 | 0.847 | 0.847 | 0.846 | 0.846 | 0.845 | 0.845 | 0.844 | 0.844 | 0.843 | 0.842 | 0.842 |
| 4.5                           | 0.771 | 0.777 | 0.776 | 0.776 | 0.775 | 0.774 | 0.774 | 0.773 | 0.773 | 0.772 | 0.772 | 0.771 | 0.770 | 0.770 |
| 5.0                           | 0.673 | 0.678 | 0.677 | 0.677 | 0.676 | 0.676 | 0.676 | 0.675 | 0.675 | 0.674 | 0.674 | 0.674 | 0.673 | 0.673 |
| 5.5                           | 0.565 | 0.567 | 0.567 | 0.567 | 0.566 | 0.566 | 0.566 | 0.566 | 0.566 | 0.566 | 0.565 | 0.565 | 0.565 | 0.565 |
| 6.0                           | 0.489 | 0.491 | 0.491 | 0.491 | 0.491 | 0.490 | 0.490 | 0.490 | 0.490 | 0.490 | 0.489 | 0.489 | 0.489 | 0.488 |
| 6.5                           | 0.445 | 0.448 | 0.447 | 0.447 | 0.447 | 0.446 | 0.446 | 0.446 | 0.446 | 0.445 | 0.445 | 0.445 | 0.444 | 0.444 |
| 7.0                           | 0.406 | 0.409 | 0.408 | 0.408 | 0.408 | 0.408 | 0.407 | 0.407 | 0.407 | 0.407 | 0.406 | 0.406 | 0.406 | 0.406 |
| 7.5                           | 0.370 | 0.372 | 0.372 | 0.372 | 0.372 | 0.371 | 0.371 | 0.371 | 0.371 | 0.371 | 0.370 | 0.370 | 0.370 | 0.370 |
| 8.0                           | 0.347 | 0.351 | 0.350 | 0.350 | 0.350 | 0.350 | 0.349 | 0.349 | 0.349 | 0.348 | 0.348 | 0.347 | 0.346 | 0.345 |
| 8.5                           | 0.325 | 0.331 | 0.331 | 0.331 | 0.331 | 0.330 | 0.330 | 0.330 | 0.329 | 0.329 | 0.328 | 0.327 | 0.324 | 0.322 |
| 9.0                           | 0.292 | 0.301 | 0.301 | 0.301 | 0.300 | 0.300 | 0.299 | 0.299 | 0.298 | 0.297 | 0.296 | 0.294 | 0.290 | 0.288 |
| 9.5                           | 0.258 | 0.276 | 0.276 | 0.275 | 0.274 | 0.273 | 0.271 | 0.269 | 0.268 | 0.266 | 0.263 | 0.261 | 0.255 | 0.252 |
| 10.0                          | 0.235 | 0.267 | 0.265 | 0.262 | 0.260 | 0.258 | 0.254 | 0.251 | 0.248 | 0.245 | 0.241 | 0.238 | 0.231 | 0.227 |
| 10.5                          | 0.215 | 0.262 | 0.258 | 0.253 | 0.249 | 0.244 | 0.240 | 0.236 | 0.231 | 0.227 | 0.223 | 0.219 | 0.211 | 0.207 |
| 11.0                          | 0.194 | 0.247 | 0.242 | 0.237 | 0.231 | 0.226 | 0.221 | 0.216 | 0.211 | 0.206 | 0.202 | 0.198 | 0.190 | 0.186 |
| 11.5                          | 0.172 | 0.223 | 0.218 | 0.212 | 0.207 | 0.201 | 0.197 | 0.192 | 0.188 | 0.183 | 0.180 | 0.176 | 0.169 | 0.166 |
| 12.0                          | 0.153 | 0.198 | 0.193 | 0.188 | 0.183 | 0.178 | 0.175 | 0.171 | 0.167 | 0.163 | 0.160 | 0.156 | 0.150 | 0.147 |
| 12.5                          | 0.137 | 0.176 | 0.172 | 0.168 | 0.163 | 0.159 | 0.156 | 0.152 | 0.149 | 0.145 | 0.143 | 0.140 | 0.134 | 0.132 |
| 13.0                          | 0.123 | 0.158 | 0.154 | 0.150 | 0.146 | 0.143 | 0.140 | 0.137 | 0.134 | 0.131 | 0.128 | 0.125 | 0.121 | 0.118 |
| 13.5                          | 0.111 | 0.143 | 0.139 | 0.136 | 0.133 | 0.129 | 0.126 | 0.124 | 0.121 | 0.118 | 0.116 | 0.114 | 0.109 | 0.107 |
| 14.0                          | 0.101 | 0.129 | 0.126 | 0.123 | 0.120 | 0.117 | 0.114 | 0.112 | 0.110 | 0.107 | 0.105 | 0.103 | 0.099 | 0.097 |
| 14.5                          | 0.092 | 0.117 | 0.114 | 0.112 | 0.109 | 0.106 | 0.104 | 0.102 | 0.100 | 0.098 | 0.096 | 0.094 | 0.090 | 0.089 |
| 15.0                          | 0.084 | 0.106 | 0.104 | 0.101 | 0.099 | 0.097 | 0.095 | 0.093 | 0.091 | 0.089 | 0.087 | 0.085 | 0.082 | 0.081 |
| 15.5                          | 0.077 | 0.097 | 0.095 | 0.093 | 0.091 | 0.089 | 0.087 | 0.085 | 0.083 | 0.081 | 0.080 | 0.078 | 0.076 | 0.074 |
| 16.0                          | 0.071 | 0.089 | 0.087 | 0.085 | 0.083 | 0.081 | 0.080 | 0.078 | 0.077 | 0.075 | 0.074 | 0.072 | 0.070 | 0.068 |
| 16.5                          | 0.065 | 0.082 | 0.080 | 0.079 | 0.077 | 0.075 | 0.074 | 0.072 | 0.071 | 0.069 | 0.068 | 0.067 | 0.064 | 0.063 |
| 17.0                          | 0.061 | 0.076 | 0.074 | 0.073 | 0.071 | 0.069 | 0.068 | 0.067 | 0.065 | 0.064 | 0.063 | 0.062 | 0.060 | 0.059 |
| 17.5                          | 0.056 | 0.070 | 0.069 | 0.067 | 0.066 | 0.064 | 0.063 | 0.062 | 0.061 | 0.059 | 0.058 | 0.057 | 0.055 | 0.054 |
| 18.0                          | 0.052 | 0.065 | 0.064 | 0.062 | 0.061 | 0.060 | 0.059 | 0.057 | 0.056 | 0.055 | 0.054 | 0.053 | 0.051 | 0.051 |
| 18.5                          | 0.049 | 0.061 | 0.059 | 0.058 | 0.057 | 0.056 | 0.055 | 0.054 | 0.052 | 0.051 | 0.051 | 0.050 | 0.048 | 0.047 |
| 19.0                          | 0.045 | 0.056 | 0.055 | 0.054 | 0.053 | 0.052 | 0.051 | 0.050 | 0.049 | 0.048 | 0.047 | 0.046 | 0.045 | 0.044 |
| 19.5                          | 0.043 | 0.053 | 0.052 | 0.050 | 0.049 | 0.048 | 0.047 | 0.047 | 0.046 | 0.045 | 0.044 | 0.043 | 0.042 | 0.041 |
| 20.0                          | 0.040 | 0.049 | 0.048 | 0.047 | 0.046 | 0.045 | 0.045 | 0.044 | 0.043 | 0.042 | 0.041 | 0.041 | 0.039 | 0.039 |
| 20.5                          | 0.038 | 0.046 | 0.045 | 0.044 | 0.043 | 0.043 | 0.042 | 0.041 | 0.040 | 0.040 | 0.039 | 0.038 | 0.037 | 0.037 |
| 21.0                          | 0.036 | 0.043 | 0.043 | 0.042 | 0.041 | 0.040 | 0.039 | 0.039 | 0.038 | 0.037 | 0.037 | 0.036 | 0.035 | 0.034 |
| 21.5                          | 0.034 | 0.041 | 0.041 | 0.040 | 0.039 | 0.038 | 0.037 | 0.037 | 0.036 | 0.035 | 0.035 | 0.034 | 0.033 | 0.033 |
| 22.0                          | 0.032 | 0.039 | 0.038 | 0.038 | 0.037 | 0.036 | 0.035 | 0.035 | 0.034 | 0.034 | 0.033 | 0.033 | 0.032 | 0.031 |
| 22.5                          | 0.031 | 0.037 | 0.036 | 0.036 | 0.035 | 0.034 | 0.034 | 0.033 | 0.033 | 0.032 | 0.031 | 0.031 | 0.030 | 0.030 |
| 23.0                          | 0.029 | 0.035 | 0.034 | 0.034 | 0.033 | 0.032 | 0.032 | 0.031 | 0.031 | 0.030 | 0.030 | 0.029 | 0.029 | 0.028 |
| 23.5                          | 0.028 | 0.033 | 0.033 | 0.032 | 0.031 | 0.031 | 0.030 | 0.030 | 0.029 | 0.029 | 0.028 | 0.028 | 0.027 | 0.027 |
| 24.0                          | 0.026 | 0.032 | 0.031 | 0.030 | 0.030 | 0.029 | 0.029 | 0.028 | 0.028 | 0.027 | 0.027 | 0.027 | 0.026 | 0.026 |
| 24.5                          | 0.025 | 0.030 | 0.030 | 0.029 | 0.029 | 0.028 | 0.028 | 0.027 | 0.027 | 0.026 | 0.026 | 0.026 | 0.025 | 0.024 |
| 25.0                          | 0.024 | 0.029 | 0.028 | 0.028 | 0.027 | 0.027 | 0.026 | 0.026 | 0.025 | 0.025 | 0.025 | 0.024 | 0.024 | 0.023 |
| 25.5                          | 0.023 | 0.027 | 0.027 | 0.026 | 0.026 | 0.026 | 0.025 | 0.025 | 0.024 | 0.024 | 0.024 | 0.023 | 0.023 | 0.022 |
| 26.0                          | 0.022 | 0.026 | 0.026 | 0.025 | 0.025 | 0.024 | 0.024 | 0.024 | 0.023 | 0.023 | 0.023 | 0.022 | 0.022 | 0.021 |
| 26.5                          | 0.021 | 0.025 | 0.025 | 0.024 | 0.024 | 0.023 | 0.023 | 0.023 | 0.022 | 0.022 | 0.022 | 0.021 | 0.021 | 0.021 |
| 27.0                          | 0.020 | 0.024 | 0.024 | 0.023 | 0.023 | 0.022 | 0.022 | 0.022 | 0.021 | 0.021 | 0.021 | 0.020 | 0.020 | 0.020 |

Table 18-2: C<sub>t</sub> values, Sound Optimized Mode SO13

### 18.3 Sound Curves, Sound Optimized Mode SO13

| Sound Power Level at Hub Height   |  |
|-----------------------------------|--|
| Conditions for Sound Power Level: | Measurement standard IEC 61400-11 ed. 3<br>Maximum turbulence at hub height: 30%<br>Inflow angle (vertical): 0 ±2°<br>Air density: 1.225 kg/m <sup>3</sup> |
| Wind speed at hub height [m/s]    | Sound Power Level at Hub Height [dBA]<br>Sound Optimized Mode SO13<br>(Blades with serrated trailing edge)   |
| 3                                 | 92.1   |
| 4                                 | 92.4   |
| 5                                 | 92.5   |
| 6                                 | 92.5   |
| 7                                 | 93.1   |
| 8                                 | 94.2   |
| 9                                 | 95.8   |
| 10                                | 96.4   |
| 11                                | 96.9   |
| 12                                | 97.0   |
| 13                                | 97.0   |
| 14                                | 97.0   |
| 15                                | 97.0   |
| 16                                | 97.0   |
| 17                                | 97.0   |
| 18                                | 97.0   |
| 19                                | 97.0   |
| 20                                | 97.0   |

*Table 18-3: Sound curves, Sound Optimized Mode SO13*

**19 Power Curves, Ct Values and Sound Curves, Sound Optimized Mode SO13 (HWO)**

**NOTE** The power curves and Ct values presented in Section 19 are only valid for low hub heights, i.e. hub heights ≤ 104 m.

**19.1 Power Curves, Sound Optimized Mode SO13 (HWO)**

| Air density [kg/m <sup>3</sup> ] |       |       |       |       |       |       |       |       |       |       |       |       |       |       |
|----------------------------------|-------|-------|-------|-------|-------|-------|-------|-------|-------|-------|-------|-------|-------|-------|
| Wind speed [m/s]                 | 1.225 | 0.950 | 0.975 | 1.000 | 1.025 | 1.050 | 1.075 | 1.100 | 1.125 | 1.150 | 1.175 | 1.200 | 1.250 | 1.275 |
| 3.0                              | 19    | 7     | 8     | 9     | 10    | 11    | 12    | 13    | 14    | 15    | 16    | 17    | 20    | 21    |
| 3.5                              | 96    | 61    | 64    | 67    | 70    | 73    | 77    | 80    | 83    | 86    | 89    | 93    | 99    | 102   |
| 4.0                              | 198   | 141   | 146   | 151   | 156   | 162   | 167   | 172   | 177   | 182   | 188   | 193   | 203   | 208   |
| 4.5                              | 317   | 234   | 242   | 249   | 257   | 264   | 272   | 280   | 287   | 295   | 302   | 310   | 325   | 332   |
| 5.0                              | 438   | 329   | 339   | 349   | 359   | 369   | 379   | 389   | 399   | 409   | 418   | 428   | 448   | 458   |
| 5.5                              | 537   | 406   | 418   | 430   | 442   | 453   | 465   | 477   | 489   | 501   | 513   | 525   | 548   | 560   |
| 6.0                              | 641   | 488   | 502   | 516   | 530   | 544   | 558   | 572   | 586   | 600   | 613   | 627   | 655   | 668   |
| 6.5                              | 768   | 588   | 605   | 621   | 637   | 654   | 670   | 687   | 703   | 719   | 736   | 752   | 784   | 800   |
| 7.0                              | 901   | 692   | 711   | 730   | 749   | 768   | 787   | 806   | 825   | 844   | 863   | 882   | 920   | 939   |
| 7.5                              | 1032  | 795   | 816   | 838   | 860   | 881   | 903   | 924   | 946   | 968   | 989   | 1010  | 1053  | 1075  |
| 8.0                              | 1191  | 923   | 947   | 972   | 997   | 1022  | 1046  | 1071  | 1096  | 1120  | 1144  | 1167  | 1213  | 1235  |
| 8.5                              | 1353  | 1057  | 1086  | 1114  | 1143  | 1171  | 1199  | 1226  | 1253  | 1281  | 1305  | 1329  | 1374  | 1395  |
| 9.0                              | 1457  | 1153  | 1184  | 1215  | 1246  | 1276  | 1305  | 1333  | 1361  | 1390  | 1412  | 1435  | 1476  | 1496  |
| 9.5                              | 1532  | 1264  | 1294  | 1324  | 1354  | 1384  | 1408  | 1432  | 1455  | 1479  | 1497  | 1514  | 1545  | 1559  |
| 10.0                             | 1634  | 1437  | 1461  | 1486  | 1510  | 1534  | 1551  | 1568  | 1584  | 1601  | 1612  | 1623  | 1642  | 1650  |
| 10.5                             | 1739  | 1634  | 1649  | 1663  | 1677  | 1692  | 1700  | 1708  | 1716  | 1724  | 1729  | 1734  | 1742  | 1745  |
| 11.0                             | 1809  | 1776  | 1782  | 1787  | 1793  | 1798  | 1800  | 1802  | 1805  | 1807  | 1807  | 1808  | 1809  | 1809  |
| 11.5                             | 1841  | 1839  | 1840  | 1840  | 1840  | 1841  | 1841  | 1841  | 1841  | 1841  | 1841  | 1841  | 1841  | 1841  |
| 12.0                             | 1863  | 1863  | 1863  | 1863  | 1863  | 1863  | 1863  | 1863  | 1863  | 1863  | 1863  | 1863  | 1863  | 1863  |
| 12.5                             | 1882  | 1883  | 1883  | 1882  | 1882  | 1882  | 1882  | 1882  | 1882  | 1882  | 1882  | 1882  | 1882  | 1881  |
| 13.0                             | 1900  | 1902  | 1901  | 1901  | 1901  | 1901  | 1901  | 1901  | 1901  | 1901  | 1901  | 1901  | 1900  | 1900  |
| 13.5                             | 1918  | 1919  | 1919  | 1919  | 1919  | 1919  | 1919  | 1919  | 1918  | 1918  | 1918  | 1918  | 1918  | 1918  |
| 14.0                             | 1934  | 1935  | 1935  | 1935  | 1935  | 1935  | 1935  | 1935  | 1935  | 1935  | 1934  | 1934  | 1934  | 1934  |
| 14.5                             | 1950  | 1952  | 1952  | 1952  | 1951  | 1951  | 1951  | 1951  | 1951  | 1951  | 1951  | 1950  | 1950  | 1950  |
| 15.0                             | 1966  | 1968  | 1968  | 1968  | 1968  | 1968  | 1968  | 1967  | 1967  | 1967  | 1967  | 1967  | 1966  | 1966  |
| 15.5                             | 1982  | 1984  | 1984  | 1984  | 1983  | 1983  | 1983  | 1983  | 1983  | 1983  | 1982  | 1982  | 1982  | 1982  |
| 16.0                             | 1996  | 1998  | 1998  | 1998  | 1998  | 1998  | 1998  | 1997  | 1997  | 1997  | 1997  | 1997  | 1996  | 1996  |
| 16.5                             | 2009  | 2011  | 2011  | 2011  | 2011  | 2011  | 2010  | 2010  | 2010  | 2010  | 2010  | 2009  | 2009  | 2009  |
| 17.0                             | 2021  | 2022  | 2022  | 2022  | 2022  | 2022  | 2022  | 2022  | 2022  | 2021  | 2021  | 2021  | 2021  | 2020  |
| 17.5                             | 2032  | 2033  | 2033  | 2033  | 2033  | 2033  | 2033  | 2032  | 2032  | 2032  | 2032  | 2032  | 2032  | 2031  |
| 18.0                             | 2042  | 2043  | 2043  | 2043  | 2043  | 2043  | 2042  | 2042  | 2042  | 2042  | 2042  | 2042  | 2041  | 2041  |
| 18.5                             | 2051  | 2052  | 2052  | 2052  | 2052  | 2052  | 2052  | 2052  | 2051  | 2051  | 2051  | 2051  | 2051  | 2050  |
| 19.0                             | 2059  | 2061  | 2061  | 2060  | 2060  | 2060  | 2060  | 2060  | 2060  | 2060  | 2060  | 2059  | 2059  | 2059  |
| 19.5                             | 2067  | 2068  | 2068  | 2068  | 2067  | 2067  | 2067  | 2067  | 2067  | 2067  | 2067  | 2067  | 2066  | 2066  |
| 20.0                             | 2072  | 2073  | 2073  | 2073  | 2073  | 2073  | 2073  | 2073  | 2073  | 2073  | 2073  | 2073  | 2072  | 2072  |
| 20.5                             | 2077  | 2078  | 2078  | 2078  | 2078  | 2078  | 2078  | 2078  | 2078  | 2078  | 2078  | 2077  | 2077  | 2077  |
| 21.0                             | 2083  | 2084  | 2084  | 2084  | 2084  | 2084  | 2084  | 2084  | 2084  | 2084  | 2083  | 2083  | 2083  | 2083  |
| 21.5                             | 2090  | 2092  | 2092  | 2092  | 2091  | 2091  | 2091  | 2091  | 2091  | 2090  | 2090  | 2090  | 2090  | 2090  |
| 22.0                             | 2099  | 2102  | 2102  | 2101  | 2101  | 2101  | 2101  | 2100  | 2100  | 2100  | 2100  | 2099  | 2099  | 2098  |
| 22.5                             | 2110  | 2113  | 2112  | 2112  | 2112  | 2112  | 2111  | 2111  | 2111  | 2111  | 2110  | 2110  | 2109  | 2109  |
| 23.0                             | 2121  | 2124  | 2124  | 2124  | 2124  | 2123  | 2123  | 2123  | 2123  | 2122  | 2122  | 2122  | 2121  | 2121  |
| 23.5                             | 2132  | 2134  | 2134  | 2134  | 2134  | 2134  | 2133  | 2133  | 2133  | 2132  | 2132  | 2132  | 2132  | 2131  |
| 24.0                             | 2140  | 2142  | 2142  | 2142  | 2142  | 2142  | 2141  | 2141  | 2141  | 2141  | 2140  | 2140  | 2140  | 2140  |
| 24.5                             | 2146  | 2148  | 2148  | 2147  | 2147  | 2147  | 2147  | 2147  | 2147  | 2146  | 2146  | 2146  | 2146  | 2146  |
| 25.0                             | 2150  | 2151  | 2151  | 2151  | 2151  | 2151  | 2151  | 2151  | 2151  | 2151  | 2151  | 2151  | 2150  | 2150  |
| 25.5                             | 2153  | 2154  | 2154  | 2154  | 2154  | 2154  | 2154  | 2154  | 2154  | 2154  | 2153  | 2153  | 2153  | 2153  |
| 26.0                             | 2154  | 2154  | 2154  | 2154  | 2154  | 2154  | 2154  | 2154  | 2154  | 2154  | 2154  | 2154  | 2154  | 2154  |
| 26.5                             | 2154  | 2154  | 2154  | 2154  | 2154  | 2154  | 2154  | 2154  | 2154  | 2154  | 2154  | 2154  | 2154  | 2154  |
| 27.0                             | 2154  | 2154  | 2154  | 2154  | 2154  | 2154  | 2154  | 2154  | 2154  | 2154  | 2154  | 2154  | 2154  | 2154  |
| 27.5                             | 2154  | 2155  | 2155  | 2155  | 2155  | 2154  | 2154  | 2154  | 2154  | 2154  | 2154  | 2154  | 2154  | 2154  |
| 28.0                             | 2154  | 2154  | 2154  | 2154  | 2154  | 2154  | 2154  | 2154  | 2154  | 2154  | 2154  | 2154  | 2154  | 2154  |

| <b>Air density [kg/m<sup>3</sup>]</b> |              |              |              |              |              |              |              |              |              |              |              |              |              |              |
|---------------------------------------|--------------|--------------|--------------|--------------|--------------|--------------|--------------|--------------|--------------|--------------|--------------|--------------|--------------|--------------|
| <b>Wind speed [m/s]</b>               | <b>1.225</b> | <b>0.950</b> | <b>0.975</b> | <b>1.000</b> | <b>1.025</b> | <b>1.050</b> | <b>1.075</b> | <b>1.100</b> | <b>1.125</b> | <b>1.150</b> | <b>1.175</b> | <b>1.200</b> | <b>1.250</b> | <b>1.275</b> |
| <b>28.5</b>                           | <b>2155</b>  | 2155         | 2155         | 2155         | 2155         | 2155         | 2155         | 2155         | 2155         | 2155         | 2155         | 2155         | 2155         | 2155         |
| <b>29.0</b>                           | <b>2154</b>  | 2155         | 2155         | 2155         | 2155         | 2154         | 2154         | 2154         | 2154         | 2154         | 2154         | 2154         | 2154         | 2154         |
| <b>29.5</b>                           | <b>2152</b>  | 2152         | 2152         | 2152         | 2152         | 2152         | 2152         | 2152         | 2152         | 2152         | 2152         | 2152         | 2152         | 2152         |
| <b>30.0</b>                           | <b>2142</b>  | 2143         | 2143         | 2143         | 2143         | 2142         | 2142         | 2142         | 2142         | 2142         | 2142         | 2142         | 2142         | 2142         |
| <b>30.5</b>                           | <b>2093</b>  | 2094         | 2094         | 2094         | 2094         | 2094         | 2094         | 2094         | 2094         | 2094         | 2093         | 2093         | 2093         | 2093         |
| <b>31.0</b>                           | <b>1979</b>  | 1979         | 1979         | 1979         | 1979         | 1979         | 1979         | 1979         | 1979         | 1979         | 1979         | 1979         | 1979         | 1979         |
| <b>31.5</b>                           | <b>1837</b>  | 1837         | 1837         | 1837         | 1837         | 1837         | 1837         | 1837         | 1837         | 1837         | 1837         | 1837         | 1837         | 1837         |
| <b>32.0</b>                           | <b>1715</b>  | 1715         | 1715         | 1715         | 1715         | 1715         | 1715         | 1715         | 1715         | 1715         | 1715         | 1715         | 1715         | 1715         |

*Table 19-1: Power curve, Sound Optimized Mode SO13 (HWO)*

**19.2 Ct Values, Sound Optimized Mode SO13 (HWO)**

| Air density kg/m <sup>3</sup> |       |       |       |       |       |       |       |       |       |       |       |       |       |       |
|-------------------------------|-------|-------|-------|-------|-------|-------|-------|-------|-------|-------|-------|-------|-------|-------|
| Wind speed [m/s]              | 1.225 | 0.950 | 0.975 | 1.000 | 1.025 | 1.050 | 1.075 | 1.100 | 1.125 | 1.150 | 1.175 | 1.200 | 1.250 | 1.275 |
| 3.0                           | 0.907 | 0.918 | 0.917 | 0.916 | 0.915 | 0.914 | 0.913 | 0.912 | 0.911 | 0.910 | 0.909 | 0.908 | 0.906 | 0.905 |
| 3.5                           | 0.875 | 0.883 | 0.882 | 0.881 | 0.881 | 0.880 | 0.879 | 0.879 | 0.878 | 0.877 | 0.876 | 0.876 | 0.874 | 0.873 |
| 4.0                           | 0.843 | 0.848 | 0.848 | 0.847 | 0.847 | 0.846 | 0.846 | 0.845 | 0.845 | 0.844 | 0.844 | 0.843 | 0.842 | 0.842 |
| 4.5                           | 0.771 | 0.777 | 0.776 | 0.776 | 0.775 | 0.774 | 0.774 | 0.773 | 0.773 | 0.772 | 0.772 | 0.771 | 0.770 | 0.770 |
| 5.0                           | 0.673 | 0.678 | 0.677 | 0.677 | 0.676 | 0.676 | 0.676 | 0.675 | 0.675 | 0.674 | 0.674 | 0.674 | 0.673 | 0.673 |
| 5.5                           | 0.565 | 0.567 | 0.567 | 0.567 | 0.566 | 0.566 | 0.566 | 0.566 | 0.566 | 0.566 | 0.565 | 0.565 | 0.565 | 0.565 |
| 6.0                           | 0.489 | 0.491 | 0.491 | 0.491 | 0.491 | 0.490 | 0.490 | 0.490 | 0.490 | 0.490 | 0.489 | 0.489 | 0.489 | 0.488 |
| 6.5                           | 0.445 | 0.448 | 0.447 | 0.447 | 0.447 | 0.446 | 0.446 | 0.446 | 0.446 | 0.445 | 0.445 | 0.445 | 0.444 | 0.444 |
| 7.0                           | 0.406 | 0.409 | 0.408 | 0.408 | 0.408 | 0.408 | 0.407 | 0.407 | 0.407 | 0.407 | 0.406 | 0.406 | 0.406 | 0.406 |
| 7.5                           | 0.370 | 0.372 | 0.372 | 0.372 | 0.372 | 0.371 | 0.371 | 0.371 | 0.371 | 0.371 | 0.370 | 0.370 | 0.370 | 0.370 |
| 8.0                           | 0.347 | 0.351 | 0.350 | 0.350 | 0.350 | 0.350 | 0.349 | 0.349 | 0.349 | 0.348 | 0.348 | 0.347 | 0.346 | 0.345 |
| 8.5                           | 0.325 | 0.331 | 0.331 | 0.331 | 0.331 | 0.330 | 0.330 | 0.330 | 0.329 | 0.329 | 0.328 | 0.327 | 0.324 | 0.322 |
| 9.0                           | 0.292 | 0.301 | 0.301 | 0.301 | 0.300 | 0.300 | 0.299 | 0.299 | 0.298 | 0.297 | 0.296 | 0.294 | 0.290 | 0.288 |
| 9.5                           | 0.258 | 0.276 | 0.276 | 0.275 | 0.274 | 0.273 | 0.271 | 0.269 | 0.268 | 0.266 | 0.263 | 0.261 | 0.255 | 0.252 |
| 10.0                          | 0.235 | 0.267 | 0.265 | 0.262 | 0.260 | 0.258 | 0.254 | 0.251 | 0.248 | 0.245 | 0.241 | 0.238 | 0.231 | 0.227 |
| 10.5                          | 0.215 | 0.262 | 0.258 | 0.253 | 0.249 | 0.244 | 0.240 | 0.236 | 0.231 | 0.227 | 0.223 | 0.219 | 0.211 | 0.207 |
| 11.0                          | 0.194 | 0.247 | 0.242 | 0.237 | 0.231 | 0.226 | 0.221 | 0.216 | 0.211 | 0.206 | 0.202 | 0.198 | 0.190 | 0.186 |
| 11.5                          | 0.172 | 0.223 | 0.218 | 0.212 | 0.207 | 0.201 | 0.197 | 0.192 | 0.188 | 0.183 | 0.180 | 0.176 | 0.169 | 0.166 |
| 12.0                          | 0.153 | 0.198 | 0.193 | 0.188 | 0.183 | 0.178 | 0.175 | 0.171 | 0.167 | 0.163 | 0.160 | 0.156 | 0.150 | 0.147 |
| 12.5                          | 0.137 | 0.176 | 0.172 | 0.168 | 0.163 | 0.159 | 0.156 | 0.152 | 0.149 | 0.145 | 0.143 | 0.140 | 0.134 | 0.132 |
| 13.0                          | 0.123 | 0.158 | 0.154 | 0.150 | 0.146 | 0.143 | 0.140 | 0.137 | 0.134 | 0.131 | 0.128 | 0.125 | 0.121 | 0.118 |
| 13.5                          | 0.111 | 0.143 | 0.139 | 0.136 | 0.133 | 0.129 | 0.126 | 0.124 | 0.121 | 0.118 | 0.116 | 0.114 | 0.109 | 0.107 |
| 14.0                          | 0.101 | 0.129 | 0.126 | 0.123 | 0.120 | 0.117 | 0.114 | 0.112 | 0.110 | 0.107 | 0.105 | 0.103 | 0.099 | 0.097 |
| 14.5                          | 0.092 | 0.117 | 0.114 | 0.112 | 0.109 | 0.106 | 0.104 | 0.102 | 0.100 | 0.098 | 0.096 | 0.094 | 0.090 | 0.089 |
| 15.0                          | 0.084 | 0.106 | 0.104 | 0.101 | 0.099 | 0.097 | 0.095 | 0.093 | 0.091 | 0.089 | 0.087 | 0.085 | 0.082 | 0.081 |
| 15.5                          | 0.077 | 0.097 | 0.095 | 0.093 | 0.091 | 0.089 | 0.087 | 0.085 | 0.083 | 0.081 | 0.080 | 0.078 | 0.076 | 0.074 |
| 16.0                          | 0.071 | 0.089 | 0.087 | 0.085 | 0.083 | 0.081 | 0.080 | 0.078 | 0.077 | 0.075 | 0.074 | 0.072 | 0.070 | 0.068 |
| 16.5                          | 0.065 | 0.082 | 0.080 | 0.079 | 0.077 | 0.075 | 0.074 | 0.072 | 0.071 | 0.069 | 0.068 | 0.067 | 0.064 | 0.063 |
| 17.0                          | 0.061 | 0.076 | 0.074 | 0.073 | 0.071 | 0.069 | 0.068 | 0.067 | 0.065 | 0.064 | 0.063 | 0.062 | 0.060 | 0.059 |
| 17.5                          | 0.056 | 0.070 | 0.069 | 0.067 | 0.066 | 0.064 | 0.063 | 0.062 | 0.061 | 0.059 | 0.058 | 0.057 | 0.055 | 0.054 |
| 18.0                          | 0.052 | 0.065 | 0.064 | 0.062 | 0.061 | 0.060 | 0.059 | 0.057 | 0.056 | 0.055 | 0.054 | 0.053 | 0.051 | 0.051 |
| 18.5                          | 0.049 | 0.061 | 0.059 | 0.058 | 0.057 | 0.056 | 0.055 | 0.054 | 0.052 | 0.051 | 0.051 | 0.050 | 0.048 | 0.047 |
| 19.0                          | 0.045 | 0.056 | 0.055 | 0.054 | 0.053 | 0.052 | 0.051 | 0.050 | 0.049 | 0.048 | 0.047 | 0.046 | 0.045 | 0.044 |
| 19.5                          | 0.043 | 0.053 | 0.052 | 0.050 | 0.049 | 0.048 | 0.047 | 0.047 | 0.046 | 0.045 | 0.044 | 0.043 | 0.042 | 0.041 |
| 20.0                          | 0.040 | 0.049 | 0.048 | 0.047 | 0.046 | 0.045 | 0.045 | 0.044 | 0.043 | 0.042 | 0.041 | 0.041 | 0.039 | 0.039 |
| 20.5                          | 0.038 | 0.046 | 0.045 | 0.044 | 0.043 | 0.043 | 0.042 | 0.041 | 0.040 | 0.040 | 0.039 | 0.038 | 0.037 | 0.037 |
| 21.0                          | 0.036 | 0.043 | 0.043 | 0.042 | 0.041 | 0.040 | 0.039 | 0.039 | 0.038 | 0.037 | 0.037 | 0.036 | 0.035 | 0.034 |
| 21.5                          | 0.034 | 0.041 | 0.041 | 0.040 | 0.039 | 0.038 | 0.037 | 0.037 | 0.036 | 0.035 | 0.035 | 0.034 | 0.033 | 0.033 |
| 22.0                          | 0.032 | 0.039 | 0.038 | 0.038 | 0.037 | 0.036 | 0.035 | 0.035 | 0.034 | 0.034 | 0.033 | 0.033 | 0.032 | 0.031 |
| 22.5                          | 0.031 | 0.037 | 0.036 | 0.036 | 0.035 | 0.034 | 0.034 | 0.033 | 0.033 | 0.032 | 0.031 | 0.031 | 0.030 | 0.030 |
| 23.0                          | 0.029 | 0.035 | 0.034 | 0.034 | 0.033 | 0.032 | 0.032 | 0.031 | 0.031 | 0.030 | 0.030 | 0.029 | 0.029 | 0.028 |
| 23.5                          | 0.028 | 0.033 | 0.033 | 0.032 | 0.031 | 0.031 | 0.030 | 0.030 | 0.029 | 0.029 | 0.028 | 0.028 | 0.027 | 0.027 |
| 24.0                          | 0.026 | 0.032 | 0.031 | 0.030 | 0.030 | 0.029 | 0.029 | 0.028 | 0.028 | 0.027 | 0.027 | 0.027 | 0.026 | 0.026 |
| 24.5                          | 0.025 | 0.030 | 0.030 | 0.029 | 0.029 | 0.028 | 0.028 | 0.027 | 0.027 | 0.026 | 0.026 | 0.026 | 0.025 | 0.024 |
| 25.0                          | 0.024 | 0.029 | 0.028 | 0.028 | 0.027 | 0.027 | 0.026 | 0.026 | 0.025 | 0.025 | 0.025 | 0.024 | 0.024 | 0.023 |
| 25.5                          | 0.023 | 0.027 | 0.027 | 0.026 | 0.026 | 0.026 | 0.025 | 0.025 | 0.024 | 0.024 | 0.024 | 0.023 | 0.023 | 0.022 |
| 26.0                          | 0.022 | 0.026 | 0.026 | 0.025 | 0.025 | 0.024 | 0.024 | 0.024 | 0.023 | 0.023 | 0.023 | 0.022 | 0.022 | 0.021 |
| 26.5                          | 0.021 | 0.025 | 0.025 | 0.024 | 0.024 | 0.023 | 0.023 | 0.023 | 0.022 | 0.022 | 0.022 | 0.021 | 0.021 | 0.021 |
| 27.0                          | 0.020 | 0.024 | 0.023 | 0.023 | 0.023 | 0.022 | 0.022 | 0.022 | 0.021 | 0.021 | 0.021 | 0.020 | 0.020 | 0.020 |
| 27.5                          | 0.019 | 0.023 | 0.022 | 0.022 | 0.022 | 0.021 | 0.021 | 0.021 | 0.020 | 0.020 | 0.020 | 0.020 | 0.019 | 0.019 |
| 28.0                          | 0.018 | 0.022 | 0.021 | 0.021 | 0.021 | 0.020 | 0.020 | 0.020 | 0.019 | 0.019 | 0.019 | 0.019 | 0.018 | 0.018 |
| 28.5                          | 0.018 | 0.021 | 0.020 | 0.020 | 0.020 | 0.019 | 0.019 | 0.019 | 0.019 | 0.018 | 0.018 | 0.018 | 0.017 | 0.017 |
| 29.0                          | 0.017 | 0.020 | 0.019 | 0.019 | 0.019 | 0.018 | 0.018 | 0.018 | 0.018 | 0.017 | 0.017 | 0.017 | 0.016 | 0.016 |
| 29.5                          | 0.016 | 0.019 | 0.018 | 0.018 | 0.018 | 0.017 | 0.017 | 0.017 | 0.017 | 0.016 | 0.016 | 0.016 | 0.016 | 0.015 |
| 30.0                          | 0.015 | 0.018 | 0.017 | 0.017 | 0.017 | 0.016 | 0.016 | 0.016 | 0.016 | 0.015 | 0.015 | 0.015 | 0.015 | 0.014 |
| 30.5                          | 0.014 | 0.016 | 0.016 | 0.016 | 0.015 | 0.015 | 0.015 | 0.015 | 0.014 | 0.014 | 0.014 | 0.014 | 0.013 | 0.013 |
| 31.0                          | 0.012 | 0.015 | 0.015 | 0.014 | 0.014 | 0.014 | 0.014 | 0.013 | 0.013 | 0.013 | 0.013 | 0.013 | 0.012 | 0.012 |
| 31.5                          | 0.011 | 0.013 | 0.013 | 0.013 | 0.013 | 0.012 | 0.012 | 0.012 | 0.012 | 0.012 | 0.011 | 0.011 | 0.011 | 0.011 |
| 32.0                          | 0.010 | 0.012 | 0.012 | 0.012 | 0.011 | 0.011 | 0.011 | 0.011 | 0.011 | 0.011 | 0.010 | 0.010 | 0.010 | 0.010 |

Table 19-2: C<sub>t</sub> values, Sound Optimized Mode SO13 (HWO)

**19.3 Sound Curves, Sound Optimized Mode SO13 (HWO)**

| <b>Sound Power Level at Hub Height</b>   |  |
|--|--|
| <b>Conditions for Sound Power Level:</b> | Measurement standard IEC 61400-11 ed. 3<br>Maximum turbulence at hub height: 30%<br>Inflow angle (vertical): 0 ±2°<br>Air density: 1.225 kg/m <sup>3</sup> |
| <b>Wind speed at hub height [m/s]</b>    | <b>Sound Power Level at Hub Height [dBA]<br/>Sound Optimized Mode SO13 (HWO)<br/>(Blades with serrated trailing edge)</b>                                  |
| 3  | 92.1   |
| 4  | 92.4   |
| 5  | 92.5   |
| 6  | 92.5   |
| 7  | 93.1   |
| 8  | 94.2   |
| 9  | 95.8   |
| 10                                       | 96.4   |
| 11                                       | 96.9   |
| 12                                       | 97.0   |
| 13                                       | 97.0   |
| 14                                       | 97.0   |
| 15                                       | 97.0   |
| 16                                       | 97.0   |
| 17                                       | 97.0   |
| 18                                       | 97.0   |
| 19                                       | 97.0   |
| 20                                       | 97.0   |

*Table 19-3: Sound curves, Sound Optimized Mode SO13 (HWO)*



## 20 Power Curves, Ct Values and Sound Curves, Load Optimized Mode LO1

**NOTE** The power curves and Ct values presented in Section 20 are only valid for low hub heights, i.e. hub heights ≤ 104 m.

### 20.1 Power Curves, Load Optimized Mode LO1

| Wind speed [m/s] | Air density [kg/m <sup>3</sup> ] |       |       |       |       |       |       |       |       |       |       |       |       |       |
|------------------|----------------------------------|-------|-------|-------|-------|-------|-------|-------|-------|-------|-------|-------|-------|-------|
|                  | 1.225                            | 0.950 | 0.975 | 1.000 | 1.025 | 1.050 | 1.075 | 1.100 | 1.125 | 1.150 | 1.175 | 1.200 | 1.250 | 1.275 |
| 3.0              | 55                               | 31    | 33    | 35    | 38    | 40    | 42    | 44    | 46    | 48    | 51    | 53    | 57    | 59    |
| 3.5              | 130                              | 89    | 93    | 97    | 100   | 104   | 108   | 111   | 115   | 119   | 122   | 126   | 133   | 137   |
| 4.0              | 220                              | 159   | 165   | 170   | 176   | 182   | 187   | 193   | 198   | 204   | 209   | 215   | 226   | 231   |
| 4.5              | 331                              | 245   | 253   | 260   | 268   | 276   | 284   | 292   | 299   | 307   | 315   | 323   | 338   | 346   |
| 5.0              | 471                              | 353   | 364   | 374   | 385   | 396   | 407   | 417   | 428   | 439   | 449   | 460   | 481   | 492   |
| 5.5              | 639                              | 483   | 497   | 511   | 526   | 540   | 554   | 568   | 582   | 596   | 610   | 624   | 653   | 667   |
| 6.0              | 841                              | 640   | 659   | 677   | 695   | 714   | 732   | 750   | 768   | 787   | 805   | 823   | 860   | 878   |
| 6.5              | 1080                             | 826   | 849   | 872   | 895   | 919   | 942   | 965   | 988   | 1011  | 1034  | 1057  | 1104  | 1127  |
| 7.0              | 1361                             | 1044  | 1073  | 1102  | 1131  | 1160  | 1189  | 1218  | 1247  | 1276  | 1304  | 1333  | 1390  | 1419  |
| 7.5              | 1681                             | 1293  | 1329  | 1364  | 1399  | 1435  | 1470  | 1505  | 1541  | 1576  | 1611  | 1646  | 1715  | 1750  |
| 8.0              | 2042                             | 1578  | 1620  | 1663  | 1706  | 1748  | 1790  | 1833  | 1875  | 1917  | 1959  | 2000  | 2083  | 2124  |
| 8.5              | 2441                             | 1897  | 1947  | 1998  | 2048  | 2099  | 2148  | 2198  | 2247  | 2296  | 2345  | 2393  | 2488  | 2535  |
| 9.0              | 2845                             | 2242  | 2300  | 2358  | 2415  | 2473  | 2527  | 2582  | 2636  | 2691  | 2742  | 2794  | 2894  | 2943  |
| 9.5              | 3208                             | 2591  | 2652  | 2713  | 2774  | 2836  | 2891  | 2947  | 3003  | 3058  | 3108  | 3158  | 3253  | 3298  |
| 10.0             | 3497                             | 2923  | 2984  | 3046  | 3107  | 3168  | 3220  | 3271  | 3322  | 3374  | 3415  | 3456  | 3529  | 3562  |
| 10.5             | 3678                             | 3221  | 3277  | 3333  | 3389  | 3444  | 3484  | 3522  | 3562  | 3600  | 3626  | 3652  | 3696  | 3714  |
| 11.0             | 3767                             | 3456  | 3499  | 3542  | 3585  | 3628  | 3653  | 3678  | 3703  | 3728  | 3741  | 3754  | 3774  | 3781  |
| 11.5             | 3795                             | 3631  | 3658  | 3685  | 3712  | 3740  | 3751  | 3762  | 3773  | 3784  | 3787  | 3791  | 3796  | 3798  |
| 12.0             | 3799                             | 3733  | 3746  | 3759  | 3772  | 3785  | 3788  | 3791  | 3795  | 3798  | 3798  | 3799  | 3800  | 3800  |
| 12.5             | 3800                             | 3777  | 3782  | 3787  | 3792  | 3798  | 3798  | 3799  | 3799  | 3800  | 3800  | 3800  | 3800  | 3800  |
| 13.0             | 3800                             | 3793  | 3794  | 3796  | 3798  | 3800  | 3800  | 3800  | 3800  | 3800  | 3800  | 3800  | 3800  | 3800  |
| 13.5             | 3800                             | 3796  | 3796  | 3798  | 3798  | 3800  | 3800  | 3800  | 3800  | 3800  | 3800  | 3800  | 3800  | 3800  |
| 14.0             | 3800                             | 3798  | 3798  | 3799  | 3800  | 3800  | 3800  | 3800  | 3800  | 3800  | 3800  | 3800  | 3800  | 3800  |
| 14.5             | 3800                             | 3799  | 3799  | 3800  | 3800  | 3800  | 3800  | 3800  | 3800  | 3800  | 3800  | 3800  | 3800  | 3800  |
| 15.0             | 3800                             | 3799  | 3799  | 3799  | 3800  | 3800  | 3800  | 3800  | 3800  | 3800  | 3800  | 3800  | 3800  | 3800  |
| 15.5             | 3800                             | 3800  | 3800  | 3800  | 3800  | 3800  | 3800  | 3800  | 3800  | 3800  | 3800  | 3800  | 3800  | 3800  |
| 16.0             | 3800                             | 3800  | 3800  | 3800  | 3800  | 3800  | 3800  | 3800  | 3800  | 3800  | 3800  | 3800  | 3800  | 3800  |
| 16.5             | 3800                             | 3800  | 3800  | 3800  | 3800  | 3800  | 3800  | 3800  | 3800  | 3800  | 3800  | 3800  | 3800  | 3800  |
| 17.0             | 3800                             | 3800  | 3800  | 3800  | 3800  | 3800  | 3800  | 3800  | 3800  | 3800  | 3800  | 3800  | 3800  | 3800  |
| 17.5             | 3800                             | 3800  | 3800  | 3800  | 3800  | 3800  | 3800  | 3800  | 3800  | 3800  | 3800  | 3800  | 3800  | 3800  |
| 18.0             | 3800                             | 3800  | 3800  | 3800  | 3800  | 3800  | 3800  | 3800  | 3800  | 3800  | 3800  | 3800  | 3800  | 3800  |
| 18.5             | 3800                             | 3800  | 3800  | 3800  | 3800  | 3800  | 3800  | 3800  | 3800  | 3800  | 3800  | 3800  | 3800  | 3800  |
| 19.0             | 3800                             | 3800  | 3800  | 3800  | 3800  | 3800  | 3800  | 3800  | 3800  | 3800  | 3800  | 3800  | 3800  | 3800  |
| 19.5             | 3800                             | 3800  | 3800  | 3800  | 3800  | 3800  | 3800  | 3800  | 3800  | 3800  | 3800  | 3800  | 3800  | 3800  |
| 20.0             | 3800                             | 3800  | 3800  | 3800  | 3800  | 3800  | 3800  | 3800  | 3800  | 3800  | 3800  | 3800  | 3800  | 3800  |
| 20.5             | 3800                             | 3800  | 3800  | 3800  | 3800  | 3800  | 3800  | 3800  | 3800  | 3800  | 3800  | 3800  | 3800  | 3800  |
| 21.0             | 3800                             | 3800  | 3800  | 3800  | 3800  | 3800  | 3800  | 3800  | 3800  | 3800  | 3800  | 3800  | 3800  | 3800  |
| 21.5             | 3800                             | 3800  | 3800  | 3800  | 3800  | 3800  | 3800  | 3800  | 3800  | 3800  | 3800  | 3800  | 3800  | 3800  |
| 22.0             | 3800                             | 3800  | 3800  | 3800  | 3800  | 3800  | 3800  | 3800  | 3800  | 3800  | 3800  | 3800  | 3800  | 3800  |
| 22.5             | 3800                             | 3800  | 3800  | 3800  | 3800  | 3800  | 3800  | 3800  | 3800  | 3800  | 3800  | 3800  | 3800  | 3800  |
| 23.0             | 3800                             | 3800  | 3800  | 3800  | 3800  | 3800  | 3800  | 3800  | 3800  | 3800  | 3800  | 3800  | 3800  | 3800  |
| 23.5             | 3800                             | 3800  | 3800  | 3800  | 3800  | 3800  | 3800  | 3800  | 3800  | 3800  | 3800  | 3800  | 3800  | 3800  |
| 24.0             | 3800                             | 3800  | 3800  | 3800  | 3800  | 3800  | 3800  | 3800  | 3800  | 3800  | 3800  | 3800  | 3800  | 3800  |
| 24.5             | 3800                             | 3800  | 3800  | 3800  | 3800  | 3800  | 3800  | 3800  | 3800  | 3800  | 3800  | 3800  | 3800  | 3800  |
| 25.0             | 3800                             | 3800  | 3800  | 3800  | 3800  | 3800  | 3800  | 3800  | 3800  | 3800  | 3800  | 3800  | 3800  | 3800  |
| 25.5             | 3800                             | 3800  | 3800  | 3800  | 3800  | 3800  | 3800  | 3800  | 3800  | 3800  | 3800  | 3800  | 3800  | 3800  |
| 26.0             | 3800                             | 3800  | 3800  | 3800  | 3800  | 3800  | 3800  | 3800  | 3800  | 3800  | 3800  | 3800  | 3800  | 3800  |
| 26.5             | 3800                             | 3800  | 3800  | 3800  | 3800  | 3800  | 3800  | 3800  | 3800  | 3800  | 3800  | 3800  | 3800  | 3800  |
| 27.0             | 3800                             | 3800  | 3800  | 3800  | 3800  | 3800  | 3800  | 3800  | 3800  | 3800  | 3800  | 3800  | 3800  | 3800  |

Table 20-1: Power curve, Load Optimized Mode LO1

**20.2 Ct Values, Load Optimized Mode LO1**

| Air density kg/m <sup>3</sup> |       |       |       |       |       |       |       |       |       |       |       |       |       |       |
|-------------------------------|-------|-------|-------|-------|-------|-------|-------|-------|-------|-------|-------|-------|-------|-------|
| Wind speed [m/s]              | 1.225 | 0.950 | 0.975 | 1.000 | 1.025 | 1.050 | 1.075 | 1.100 | 1.125 | 1.150 | 1.175 | 1.200 | 1.250 | 1.275 |
| 3.0                           | 0.873 | 0.878 | 0.877 | 0.877 | 0.876 | 0.876 | 0.876 | 0.875 | 0.875 | 0.874 | 0.874 | 0.874 | 0.873 | 0.873 |
| 3.5                           | 0.847 | 0.851 | 0.851 | 0.850 | 0.850 | 0.850 | 0.849 | 0.849 | 0.849 | 0.848 | 0.848 | 0.848 | 0.847 | 0.846 |
| 4.0                           | 0.845 | 0.854 | 0.853 | 0.851 | 0.850 | 0.848 | 0.848 | 0.848 | 0.847 | 0.847 | 0.847 | 0.846 | 0.845 | 0.845 |
| 4.5                           | 0.843 | 0.842 | 0.842 | 0.843 | 0.843 | 0.843 | 0.843 | 0.843 | 0.844 | 0.844 | 0.843 | 0.843 | 0.843 | 0.843 |
| 5.0                           | 0.844 | 0.848 | 0.848 | 0.848 | 0.847 | 0.847 | 0.847 | 0.846 | 0.846 | 0.846 | 0.845 | 0.845 | 0.844 | 0.843 |
| 5.5                           | 0.840 | 0.845 | 0.845 | 0.844 | 0.844 | 0.843 | 0.843 | 0.842 | 0.842 | 0.841 | 0.841 | 0.840 | 0.839 | 0.839 |
| 6.0                           | 0.834 | 0.840 | 0.840 | 0.839 | 0.839 | 0.838 | 0.838 | 0.837 | 0.836 | 0.836 | 0.835 | 0.835 | 0.834 | 0.833 |
| 6.5                           | 0.828 | 0.836 | 0.835 | 0.835 | 0.834 | 0.833 | 0.833 | 0.832 | 0.831 | 0.831 | 0.830 | 0.829 | 0.827 | 0.827 |
| 7.0                           | 0.821 | 0.831 | 0.830 | 0.829 | 0.828 | 0.828 | 0.827 | 0.826 | 0.825 | 0.824 | 0.823 | 0.822 | 0.820 | 0.819 |
| 7.5                           | 0.814 | 0.825 | 0.824 | 0.823 | 0.822 | 0.822 | 0.820 | 0.819 | 0.818 | 0.817 | 0.816 | 0.815 | 0.813 | 0.812 |
| 8.0                           | 0.816 | 0.830 | 0.829 | 0.828 | 0.826 | 0.825 | 0.824 | 0.823 | 0.821 | 0.820 | 0.819 | 0.817 | 0.814 | 0.812 |
| 8.5                           | 0.799 | 0.831 | 0.829 | 0.827 | 0.825 | 0.823 | 0.820 | 0.816 | 0.813 | 0.810 | 0.806 | 0.803 | 0.795 | 0.791 |
| 9.0                           | 0.746 | 0.807 | 0.802 | 0.798 | 0.793 | 0.788 | 0.782 | 0.776 | 0.771 | 0.765 | 0.759 | 0.752 | 0.739 | 0.733 |
| 9.5                           | 0.673 | 0.753 | 0.746 | 0.739 | 0.732 | 0.725 | 0.718 | 0.711 | 0.703 | 0.696 | 0.688 | 0.681 | 0.665 | 0.657 |
| 10.0                          | 0.597 | 0.688 | 0.680 | 0.672 | 0.664 | 0.656 | 0.648 | 0.640 | 0.631 | 0.623 | 0.614 | 0.605 | 0.587 | 0.578 |
| 10.5                          | 0.519 | 0.624 | 0.616 | 0.607 | 0.598 | 0.589 | 0.579 | 0.570 | 0.560 | 0.550 | 0.540 | 0.529 | 0.509 | 0.499 |
| 11.0                          | 0.446 | 0.561 | 0.550 | 0.540 | 0.530 | 0.520 | 0.509 | 0.498 | 0.488 | 0.477 | 0.467 | 0.457 | 0.437 | 0.427 |
| 11.5                          | 0.382 | 0.499 | 0.488 | 0.476 | 0.465 | 0.454 | 0.443 | 0.432 | 0.421 | 0.411 | 0.401 | 0.391 | 0.373 | 0.364 |
| 12.0                          | 0.329 | 0.439 | 0.427 | 0.416 | 0.404 | 0.393 | 0.383 | 0.373 | 0.363 | 0.353 | 0.345 | 0.337 | 0.321 | 0.314 |
| 12.5                          | 0.286 | 0.382 | 0.372 | 0.361 | 0.351 | 0.340 | 0.332 | 0.323 | 0.315 | 0.307 | 0.300 | 0.293 | 0.280 | 0.274 |
| 13.0                          | 0.251 | 0.333 | 0.324 | 0.315 | 0.306 | 0.297 | 0.290 | 0.283 | 0.276 | 0.269 | 0.263 | 0.257 | 0.246 | 0.241 |
| 13.5                          | 0.224 | 0.295 | 0.287 | 0.279 | 0.271 | 0.264 | 0.257 | 0.251 | 0.245 | 0.239 | 0.234 | 0.229 | 0.219 | 0.215 |
| 14.0                          | 0.199 | 0.261 | 0.254 | 0.247 | 0.241 | 0.234 | 0.229 | 0.223 | 0.218 | 0.213 | 0.208 | 0.204 | 0.196 | 0.192 |
| 14.5                          | 0.179 | 0.233 | 0.227 | 0.221 | 0.215 | 0.209 | 0.205 | 0.200 | 0.195 | 0.191 | 0.187 | 0.183 | 0.175 | 0.172 |
| 15.0                          | 0.160 | 0.208 | 0.203 | 0.197 | 0.192 | 0.187 | 0.183 | 0.179 | 0.175 | 0.171 | 0.167 | 0.164 | 0.157 | 0.154 |
| 15.5                          | 0.145 | 0.187 | 0.183 | 0.178 | 0.174 | 0.169 | 0.165 | 0.162 | 0.158 | 0.155 | 0.151 | 0.148 | 0.143 | 0.140 |
| 16.0                          | 0.132 | 0.170 | 0.166 | 0.162 | 0.158 | 0.153 | 0.150 | 0.147 | 0.144 | 0.140 | 0.138 | 0.135 | 0.130 | 0.127 |
| 16.5                          | 0.121 | 0.154 | 0.151 | 0.147 | 0.144 | 0.140 | 0.137 | 0.134 | 0.131 | 0.128 | 0.126 | 0.123 | 0.118 | 0.116 |
| 17.0                          | 0.111 | 0.141 | 0.138 | 0.135 | 0.131 | 0.128 | 0.125 | 0.123 | 0.120 | 0.117 | 0.115 | 0.113 | 0.109 | 0.107 |
| 17.5                          | 0.101 | 0.129 | 0.126 | 0.123 | 0.120 | 0.117 | 0.115 | 0.112 | 0.110 | 0.108 | 0.106 | 0.104 | 0.100 | 0.098 |
| 18.0                          | 0.094 | 0.119 | 0.116 | 0.113 | 0.111 | 0.108 | 0.106 | 0.104 | 0.101 | 0.099 | 0.097 | 0.095 | 0.092 | 0.090 |
| 18.5                          | 0.087 | 0.110 | 0.107 | 0.105 | 0.102 | 0.100 | 0.098 | 0.096 | 0.094 | 0.092 | 0.090 | 0.088 | 0.085 | 0.084 |
| 19.0                          | 0.080 | 0.101 | 0.099 | 0.096 | 0.094 | 0.092 | 0.090 | 0.088 | 0.086 | 0.085 | 0.083 | 0.081 | 0.079 | 0.077 |
| 19.5                          | 0.074 | 0.094 | 0.091 | 0.089 | 0.087 | 0.085 | 0.084 | 0.082 | 0.080 | 0.079 | 0.077 | 0.076 | 0.073 | 0.072 |
| 20.0                          | 0.069 | 0.087 | 0.085 | 0.083 | 0.081 | 0.079 | 0.078 | 0.076 | 0.075 | 0.073 | 0.072 | 0.071 | 0.068 | 0.067 |
| 20.5                          | 0.065 | 0.081 | 0.079 | 0.078 | 0.076 | 0.074 | 0.073 | 0.071 | 0.070 | 0.068 | 0.067 | 0.066 | 0.064 | 0.063 |
| 21.0                          | 0.061 | 0.076 | 0.074 | 0.072 | 0.071 | 0.069 | 0.068 | 0.067 | 0.065 | 0.064 | 0.063 | 0.062 | 0.060 | 0.059 |
| 21.5                          | 0.057 | 0.071 | 0.070 | 0.068 | 0.067 | 0.065 | 0.064 | 0.063 | 0.062 | 0.061 | 0.059 | 0.058 | 0.056 | 0.056 |
| 22.0                          | 0.054 | 0.067 | 0.066 | 0.064 | 0.063 | 0.061 | 0.060 | 0.059 | 0.058 | 0.057 | 0.056 | 0.055 | 0.053 | 0.052 |
| 22.5                          | 0.051 | 0.063 | 0.062 | 0.060 | 0.059 | 0.058 | 0.057 | 0.056 | 0.055 | 0.054 | 0.053 | 0.052 | 0.050 | 0.049 |
| 23.0                          | 0.048 | 0.059 | 0.058 | 0.057 | 0.055 | 0.054 | 0.053 | 0.052 | 0.051 | 0.050 | 0.049 | 0.049 | 0.047 | 0.046 |
| 23.5                          | 0.045 | 0.056 | 0.054 | 0.053 | 0.052 | 0.051 | 0.050 | 0.049 | 0.048 | 0.047 | 0.047 | 0.046 | 0.044 | 0.044 |
| 24.0                          | 0.043 | 0.053 | 0.052 | 0.050 | 0.049 | 0.048 | 0.048 | 0.047 | 0.046 | 0.045 | 0.044 | 0.044 | 0.042 | 0.042 |
| 24.5                          | 0.041 | 0.050 | 0.049 | 0.048 | 0.047 | 0.046 | 0.045 | 0.044 | 0.043 | 0.043 | 0.042 | 0.041 | 0.040 | 0.039 |
| 25.0                          | 0.039 | 0.047 | 0.046 | 0.045 | 0.044 | 0.043 | 0.043 | 0.042 | 0.041 | 0.040 | 0.040 | 0.039 | 0.038 | 0.037 |
| 25.5                          | 0.037 | 0.045 | 0.044 | 0.043 | 0.042 | 0.042 | 0.041 | 0.040 | 0.039 | 0.039 | 0.038 | 0.038 | 0.036 | 0.036 |
| 26.0                          | 0.035 | 0.043 | 0.042 | 0.041 | 0.040 | 0.039 | 0.039 | 0.038 | 0.038 | 0.037 | 0.036 | 0.036 | 0.035 | 0.034 |
| 26.5                          | 0.034 | 0.041 | 0.040 | 0.039 | 0.038 | 0.038 | 0.037 | 0.036 | 0.036 | 0.035 | 0.035 | 0.034 | 0.033 | 0.033 |
| 27.0                          | 0.032 | 0.039 | 0.038 | 0.037 | 0.037 | 0.036 | 0.035 | 0.035 | 0.034 | 0.034 | 0.033 | 0.033 | 0.032 | 0.031 |

Table 20-2: C<sub>t</sub> values, Load Optimized Mode LO1

### 20.3 Sound Curves, Load Optimized Mode LO1

| Sound Power Level at Hub Height   |  |
|-----------------------------------|--|
| Conditions for Sound Power Level: | Measurement standard IEC 61400-11 ed. 3<br>Maximum turbulence at hub height: 30%<br>Inflow angle (vertical): 0 ±2°<br>Air density: 1.225 kg/m <sup>3</sup> |
| Wind speed at hub height [m/s]    | Sound Power Level at Hub Height [dBA]<br>Load Optimized Mode LO1<br>(Blades with serrated trailing edge)   |
| 3                                 | 90.9   |
| 4                                 | 91.1   |
| 5                                 | 92.8   |
| 6                                 | 95.9   |
| 7                                 | 99.5   |
| 8                                 | 102.8  |
| 9                                 | 103.9  |
| 10                                | 103.9  |
| 11                                | 103.9  |
| 12                                | 103.9  |
| 13                                | 103.9  |
| 14                                | 103.9  |
| 15                                | 103.9  |
| 16                                | 103.9  |
| 17                                | 103.9  |
| 18                                | 103.9  |
| 19                                | 103.9  |
| 20                                | 103.9  |

*Table 20-3: Sound curves, Load Optimized Mode LO1*

**21 Power Curves, Ct Values and Sound Curves, Load Optimized Mode LO1 (HWO)**

**NOTE** The power curves and Ct values presented in Section 21 are only valid for low hub heights, i.e. hub heights ≤ 104 m.

**21.1 Power Curves, Load Optimized Mode LO1 (HWO)**

| Wind speed [m/s] | Air density [kg/m <sup>3</sup> ] |       |       |       |       |       |       |       |       |       |       |       |       |       |
|------------------|----------------------------------|-------|-------|-------|-------|-------|-------|-------|-------|-------|-------|-------|-------|-------|
|                  | 1.225                            | 0.950 | 0.975 | 1.000 | 1.025 | 1.050 | 1.075 | 1.100 | 1.125 | 1.150 | 1.175 | 1.200 | 1.250 | 1.275 |
| 3.0              | 55                               | 31    | 33    | 35    | 38    | 40    | 42    | 44    | 46    | 48    | 51    | 53    | 57    | 59    |
| 3.5              | 130                              | 89    | 93    | 97    | 100   | 104   | 108   | 111   | 115   | 119   | 122   | 126   | 133   | 137   |
| 4.0              | 220                              | 159   | 165   | 170   | 176   | 182   | 187   | 193   | 198   | 204   | 209   | 215   | 226   | 231   |
| 4.5              | 331                              | 245   | 253   | 260   | 268   | 276   | 284   | 292   | 299   | 307   | 315   | 323   | 338   | 346   |
| 5.0              | 471                              | 353   | 364   | 374   | 385   | 396   | 407   | 417   | 428   | 439   | 449   | 460   | 481   | 492   |
| 5.5              | 639                              | 483   | 497   | 511   | 526   | 540   | 554   | 568   | 582   | 596   | 610   | 624   | 653   | 667   |
| 6.0              | 841                              | 640   | 659   | 677   | 695   | 714   | 732   | 750   | 768   | 787   | 805   | 823   | 860   | 878   |
| 6.5              | 1080                             | 826   | 849   | 872   | 895   | 919   | 942   | 965   | 988   | 1011  | 1034  | 1057  | 1104  | 1127  |
| 7.0              | 1361                             | 1044  | 1073  | 1102  | 1131  | 1160  | 1189  | 1218  | 1247  | 1276  | 1304  | 1333  | 1390  | 1419  |
| 7.5              | 1681                             | 1293  | 1329  | 1364  | 1399  | 1435  | 1470  | 1505  | 1541  | 1576  | 1611  | 1646  | 1715  | 1750  |
| 8.0              | 2042                             | 1578  | 1620  | 1663  | 1706  | 1748  | 1790  | 1833  | 1875  | 1917  | 1959  | 2000  | 2083  | 2124  |
| 8.5              | 2441                             | 1897  | 1947  | 1998  | 2048  | 2099  | 2148  | 2198  | 2247  | 2296  | 2345  | 2393  | 2488  | 2535  |
| 9.0              | 2845                             | 2242  | 2300  | 2358  | 2415  | 2473  | 2527  | 2582  | 2636  | 2691  | 2742  | 2794  | 2894  | 2943  |
| 9.5              | 3208                             | 2591  | 2652  | 2713  | 2774  | 2836  | 2891  | 2947  | 3003  | 3058  | 3108  | 3158  | 3253  | 3298  |
| 10.0             | 3497                             | 2923  | 2984  | 3046  | 3107  | 3168  | 3220  | 3271  | 3322  | 3374  | 3415  | 3456  | 3529  | 3562  |
| 10.5             | 3678                             | 3221  | 3277  | 3333  | 3389  | 3444  | 3484  | 3522  | 3562  | 3600  | 3626  | 3652  | 3696  | 3714  |
| 11.0             | 3767                             | 3456  | 3499  | 3542  | 3585  | 3628  | 3653  | 3678  | 3703  | 3728  | 3741  | 3754  | 3774  | 3781  |
| 11.5             | 3795                             | 3631  | 3658  | 3685  | 3712  | 3740  | 3751  | 3762  | 3773  | 3784  | 3787  | 3791  | 3796  | 3798  |
| 12.0             | 3799                             | 3733  | 3746  | 3759  | 3772  | 3785  | 3788  | 3791  | 3795  | 3798  | 3798  | 3799  | 3800  | 3800  |
| 12.5             | 3800                             | 3777  | 3782  | 3787  | 3792  | 3798  | 3798  | 3799  | 3799  | 3800  | 3800  | 3800  | 3800  | 3800  |
| 13.0             | 3800                             | 3793  | 3794  | 3796  | 3798  | 3800  | 3800  | 3800  | 3800  | 3800  | 3800  | 3800  | 3800  | 3800  |
| 13.5             | 3800                             | 3796  | 3796  | 3798  | 3798  | 3800  | 3800  | 3800  | 3800  | 3800  | 3800  | 3800  | 3800  | 3800  |
| 14.0             | 3800                             | 3798  | 3798  | 3799  | 3800  | 3800  | 3800  | 3800  | 3800  | 3800  | 3800  | 3800  | 3800  | 3800  |
| 14.5             | 3800                             | 3799  | 3799  | 3800  | 3800  | 3800  | 3800  | 3800  | 3800  | 3800  | 3800  | 3800  | 3800  | 3800  |
| 15.0             | 3800                             | 3799  | 3799  | 3799  | 3800  | 3800  | 3800  | 3800  | 3800  | 3800  | 3800  | 3800  | 3800  | 3800  |
| 15.5             | 3800                             | 3800  | 3800  | 3800  | 3800  | 3800  | 3800  | 3800  | 3800  | 3800  | 3800  | 3800  | 3800  | 3800  |
| 16.0             | 3800                             | 3800  | 3800  | 3800  | 3800  | 3800  | 3800  | 3800  | 3800  | 3800  | 3800  | 3800  | 3800  | 3800  |
| 16.5             | 3800                             | 3800  | 3800  | 3800  | 3800  | 3800  | 3800  | 3800  | 3800  | 3800  | 3800  | 3800  | 3800  | 3800  |
| 17.0             | 3800                             | 3800  | 3800  | 3800  | 3800  | 3800  | 3800  | 3800  | 3800  | 3800  | 3800  | 3800  | 3800  | 3800  |
| 17.5             | 3800                             | 3800  | 3800  | 3800  | 3800  | 3800  | 3800  | 3800  | 3800  | 3800  | 3800  | 3800  | 3800  | 3800  |
| 18.0             | 3800                             | 3800  | 3800  | 3800  | 3800  | 3800  | 3800  | 3800  | 3800  | 3800  | 3800  | 3800  | 3800  | 3800  |
| 18.5             | 3800                             | 3800  | 3800  | 3800  | 3800  | 3800  | 3800  | 3800  | 3800  | 3800  | 3800  | 3800  | 3800  | 3800  |
| 19.0             | 3800                             | 3800  | 3800  | 3800  | 3800  | 3800  | 3800  | 3800  | 3800  | 3800  | 3800  | 3800  | 3800  | 3800  |
| 19.5             | 3800                             | 3800  | 3800  | 3800  | 3800  | 3800  | 3800  | 3800  | 3800  | 3800  | 3800  | 3800  | 3800  | 3800  |
| 20.0             | 3800                             | 3800  | 3800  | 3800  | 3800  | 3800  | 3800  | 3800  | 3800  | 3800  | 3800  | 3800  | 3800  | 3800  |
| 20.5             | 3800                             | 3800  | 3800  | 3800  | 3800  | 3800  | 3800  | 3800  | 3800  | 3800  | 3800  | 3800  | 3800  | 3800  |
| 21.0             | 3800                             | 3800  | 3800  | 3800  | 3800  | 3800  | 3800  | 3800  | 3800  | 3800  | 3800  | 3800  | 3800  | 3800  |
| 21.5             | 3800                             | 3800  | 3800  | 3800  | 3800  | 3800  | 3800  | 3800  | 3800  | 3800  | 3800  | 3800  | 3800  | 3800  |
| 22.0             | 3800                             | 3800  | 3800  | 3800  | 3800  | 3800  | 3800  | 3800  | 3800  | 3800  | 3800  | 3800  | 3800  | 3800  |
| 22.5             | 3800                             | 3800  | 3800  | 3800  | 3800  | 3800  | 3800  | 3800  | 3800  | 3800  | 3800  | 3800  | 3800  | 3800  |
| 23.0             | 3800                             | 3800  | 3800  | 3800  | 3800  | 3800  | 3800  | 3800  | 3800  | 3800  | 3800  | 3800  | 3800  | 3800  |
| 23.5             | 3800                             | 3800  | 3800  | 3800  | 3800  | 3800  | 3800  | 3800  | 3800  | 3800  | 3800  | 3800  | 3800  | 3800  |
| 24.0             | 3800                             | 3800  | 3800  | 3800  | 3800  | 3800  | 3800  | 3800  | 3800  | 3800  | 3800  | 3800  | 3800  | 3800  |
| 24.5             | 3800                             | 3800  | 3800  | 3800  | 3800  | 3800  | 3800  | 3800  | 3800  | 3800  | 3800  | 3800  | 3800  | 3800  |
| 25.0             | 3800                             | 3800  | 3800  | 3800  | 3800  | 3800  | 3800  | 3800  | 3800  | 3800  | 3800  | 3800  | 3800  | 3800  |
| 25.5             | 3798                             | 3798  | 3798  | 3798  | 3798  | 3798  | 3798  | 3798  | 3798  | 3798  | 3798  | 3798  | 3798  | 3798  |
| 26.0             | 3790                             | 3790  | 3790  | 3790  | 3790  | 3790  | 3790  | 3790  | 3790  | 3790  | 3790  | 3790  | 3790  | 3790  |
| 26.5             | 3759                             | 3759  | 3759  | 3759  | 3759  | 3759  | 3759  | 3759  | 3759  | 3759  | 3759  | 3759  | 3759  | 3759  |
| 27.0             | 3722                             | 3722  | 3722  | 3722  | 3722  | 3722  | 3722  | 3722  | 3723  | 3722  | 3722  | 3722  | 3722  | 3722  |
| 27.5             | 3621                             | 3621  | 3621  | 3621  | 3621  | 3621  | 3621  | 3621  | 3621  | 3621  | 3621  | 3621  | 3621  | 3621  |
| 28.0             | 3467                             | 3467  | 3467  | 3467  | 3467  | 3467  | 3467  | 3467  | 3467  | 3467  | 3467  | 3467  | 3467  | 3467  |

| <b>Air density [kg/m<sup>3</sup>]</b> |              |              |              |              |              |              |              |              |              |              |              |              |              |              |
|---------------------------------------|--------------|--------------|--------------|--------------|--------------|--------------|--------------|--------------|--------------|--------------|--------------|--------------|--------------|--------------|
| <b>Wind speed [m/s]</b>               | <b>1.225</b> | <b>0.950</b> | <b>0.975</b> | <b>1.000</b> | <b>1.025</b> | <b>1.050</b> | <b>1.075</b> | <b>1.100</b> | <b>1.125</b> | <b>1.150</b> | <b>1.175</b> | <b>1.200</b> | <b>1.250</b> | <b>1.275</b> |
| <b>28.5</b>                           | <b>3275</b>  | 3275         | 3275         | 3275         | 3275         | 3275         | 3275         | 3275         | 3275         | 3275         | 3275         | 3275         | 3275         | 3275         |
| <b>29.0</b>                           | <b>3049</b>  | 3049         | 3049         | 3049         | 3049         | 3049         | 3049         | 3049         | 3049         | 3049         | 3049         | 3049         | 3049         | 3049         |
| <b>29.5</b>                           | <b>2806</b>  | 2806         | 2806         | 2806         | 2806         | 2806         | 2806         | 2806         | 2806         | 2806         | 2806         | 2806         | 2806         | 2806         |
| <b>30.0</b>                           | <b>2565</b>  | 2565         | 2565         | 2565         | 2565         | 2565         | 2565         | 2565         | 2565         | 2565         | 2565         | 2565         | 2565         | 2565         |
| <b>30.5</b>                           | <b>2324</b>  | 2324         | 2324         | 2324         | 2324         | 2324         | 2324         | 2324         | 2324         | 2325         | 2325         | 2325         | 2325         | 2324         |
| <b>31.0</b>                           | <b>2090</b>  | 2090         | 2090         | 2090         | 2090         | 2090         | 2090         | 2090         | 2090         | 2090         | 2090         | 2090         | 2090         | 2090         |
| <b>31.5</b>                           | <b>1884</b>  | 1884         | 1884         | 1884         | 1884         | 1884         | 1884         | 1884         | 1884         | 1884         | 1884         | 1884         | 1884         | 1884         |
| <b>32.0</b>                           | <b>1732</b>  | 1732         | 1732         | 1732         | 1732         | 1732         | 1732         | 1732         | 1732         | 1732         | 1732         | 1732         | 1732         | 1732         |

*Table 21-1: Power curve, Load Optimized Mode LO1 (HWO)*

**21.2 Ct Values, Load Optimized Mode LO1 (HWO)**

| Air density kg/m <sup>3</sup> |       |       |       |       |       |       |       |       |       |       |       |       |       |       |
|-------------------------------|-------|-------|-------|-------|-------|-------|-------|-------|-------|-------|-------|-------|-------|-------|
| Wind speed [m/s]              | 1.225 | 0.950 | 0.975 | 1.000 | 1.025 | 1.050 | 1.075 | 1.100 | 1.125 | 1.150 | 1.175 | 1.200 | 1.250 | 1.275 |
| 3.0                           | 0.873 | 0.878 | 0.877 | 0.877 | 0.876 | 0.876 | 0.876 | 0.875 | 0.875 | 0.874 | 0.874 | 0.874 | 0.873 | 0.873 |
| 3.5                           | 0.847 | 0.851 | 0.851 | 0.850 | 0.850 | 0.850 | 0.849 | 0.849 | 0.849 | 0.848 | 0.848 | 0.848 | 0.847 | 0.846 |
| 4.0                           | 0.845 | 0.854 | 0.853 | 0.851 | 0.850 | 0.848 | 0.848 | 0.848 | 0.847 | 0.847 | 0.847 | 0.846 | 0.845 | 0.845 |
| 4.5                           | 0.836 | 0.845 | 0.843 | 0.842 | 0.841 | 0.839 | 0.839 | 0.838 | 0.838 | 0.837 | 0.837 | 0.836 | 0.835 | 0.835 |
| 5.0                           | 0.843 | 0.842 | 0.842 | 0.843 | 0.843 | 0.843 | 0.843 | 0.843 | 0.844 | 0.844 | 0.843 | 0.843 | 0.843 | 0.843 |
| 5.5                           | 0.844 | 0.848 | 0.848 | 0.848 | 0.847 | 0.847 | 0.847 | 0.846 | 0.846 | 0.846 | 0.845 | 0.845 | 0.844 | 0.843 |
| 6.0                           | 0.840 | 0.845 | 0.845 | 0.844 | 0.844 | 0.843 | 0.843 | 0.842 | 0.842 | 0.841 | 0.841 | 0.840 | 0.839 | 0.839 |
| 6.5                           | 0.834 | 0.840 | 0.840 | 0.839 | 0.839 | 0.838 | 0.838 | 0.837 | 0.836 | 0.836 | 0.835 | 0.835 | 0.834 | 0.833 |
| 7.0                           | 0.828 | 0.836 | 0.835 | 0.835 | 0.834 | 0.833 | 0.833 | 0.832 | 0.831 | 0.831 | 0.830 | 0.829 | 0.827 | 0.827 |
| 7.5                           | 0.821 | 0.831 | 0.830 | 0.829 | 0.828 | 0.828 | 0.827 | 0.826 | 0.825 | 0.824 | 0.823 | 0.822 | 0.820 | 0.819 |
| 8.0                           | 0.814 | 0.825 | 0.824 | 0.823 | 0.822 | 0.822 | 0.820 | 0.819 | 0.818 | 0.817 | 0.816 | 0.815 | 0.813 | 0.812 |
| 8.5                           | 0.816 | 0.830 | 0.829 | 0.828 | 0.826 | 0.825 | 0.824 | 0.823 | 0.821 | 0.820 | 0.819 | 0.817 | 0.814 | 0.812 |
| 9.0                           | 0.799 | 0.831 | 0.829 | 0.827 | 0.825 | 0.823 | 0.820 | 0.816 | 0.813 | 0.810 | 0.806 | 0.803 | 0.795 | 0.791 |
| 9.5                           | 0.746 | 0.807 | 0.802 | 0.798 | 0.793 | 0.788 | 0.782 | 0.776 | 0.771 | 0.765 | 0.759 | 0.752 | 0.739 | 0.733 |
| 10.0                          | 0.673 | 0.753 | 0.746 | 0.739 | 0.732 | 0.725 | 0.718 | 0.711 | 0.703 | 0.696 | 0.688 | 0.681 | 0.665 | 0.657 |
| 10.5                          | 0.597 | 0.688 | 0.680 | 0.672 | 0.664 | 0.656 | 0.648 | 0.640 | 0.631 | 0.623 | 0.614 | 0.605 | 0.587 | 0.578 |
| 11.0                          | 0.519 | 0.624 | 0.616 | 0.607 | 0.598 | 0.589 | 0.579 | 0.570 | 0.560 | 0.550 | 0.540 | 0.529 | 0.509 | 0.499 |
| 11.5                          | 0.446 | 0.561 | 0.550 | 0.540 | 0.530 | 0.520 | 0.509 | 0.498 | 0.488 | 0.477 | 0.467 | 0.457 | 0.437 | 0.427 |
| 12.0                          | 0.382 | 0.499 | 0.488 | 0.476 | 0.465 | 0.454 | 0.443 | 0.432 | 0.421 | 0.411 | 0.401 | 0.391 | 0.373 | 0.364 |
| 12.5                          | 0.329 | 0.439 | 0.427 | 0.416 | 0.404 | 0.393 | 0.383 | 0.373 | 0.363 | 0.353 | 0.345 | 0.337 | 0.321 | 0.314 |
| 13.0                          | 0.286 | 0.382 | 0.372 | 0.361 | 0.351 | 0.340 | 0.332 | 0.323 | 0.315 | 0.307 | 0.300 | 0.293 | 0.280 | 0.274 |
| 13.5                          | 0.251 | 0.333 | 0.324 | 0.315 | 0.306 | 0.297 | 0.290 | 0.283 | 0.276 | 0.269 | 0.263 | 0.257 | 0.246 | 0.241 |
| 14.0                          | 0.224 | 0.295 | 0.287 | 0.279 | 0.271 | 0.264 | 0.257 | 0.251 | 0.245 | 0.239 | 0.234 | 0.229 | 0.219 | 0.215 |
| 14.5                          | 0.199 | 0.261 | 0.254 | 0.247 | 0.241 | 0.234 | 0.229 | 0.223 | 0.218 | 0.213 | 0.208 | 0.204 | 0.196 | 0.192 |
| 15.0                          | 0.179 | 0.233 | 0.227 | 0.221 | 0.215 | 0.209 | 0.205 | 0.200 | 0.195 | 0.191 | 0.187 | 0.183 | 0.175 | 0.172 |
| 15.5                          | 0.160 | 0.208 | 0.203 | 0.197 | 0.192 | 0.187 | 0.183 | 0.179 | 0.175 | 0.171 | 0.167 | 0.164 | 0.157 | 0.154 |
| 16.0                          | 0.145 | 0.187 | 0.183 | 0.178 | 0.174 | 0.169 | 0.165 | 0.162 | 0.158 | 0.155 | 0.151 | 0.148 | 0.143 | 0.140 |
| 16.5                          | 0.132 | 0.170 | 0.166 | 0.162 | 0.158 | 0.153 | 0.150 | 0.147 | 0.144 | 0.140 | 0.138 | 0.135 | 0.130 | 0.127 |
| 17.0                          | 0.121 | 0.154 | 0.151 | 0.147 | 0.144 | 0.140 | 0.137 | 0.134 | 0.131 | 0.128 | 0.126 | 0.123 | 0.118 | 0.116 |
| 17.5                          | 0.111 | 0.141 | 0.138 | 0.135 | 0.131 | 0.128 | 0.125 | 0.123 | 0.120 | 0.117 | 0.115 | 0.113 | 0.109 | 0.107 |
| 18.0                          | 0.101 | 0.129 | 0.126 | 0.123 | 0.120 | 0.117 | 0.115 | 0.112 | 0.110 | 0.108 | 0.106 | 0.104 | 0.100 | 0.098 |
| 18.5                          | 0.094 | 0.119 | 0.116 | 0.113 | 0.111 | 0.108 | 0.106 | 0.104 | 0.101 | 0.099 | 0.097 | 0.095 | 0.092 | 0.090 |
| 19.0                          | 0.087 | 0.110 | 0.107 | 0.105 | 0.102 | 0.100 | 0.098 | 0.096 | 0.094 | 0.092 | 0.090 | 0.088 | 0.085 | 0.084 |
| 19.5                          | 0.080 | 0.101 | 0.099 | 0.096 | 0.094 | 0.092 | 0.090 | 0.088 | 0.086 | 0.085 | 0.083 | 0.081 | 0.079 | 0.077 |
| 20.0                          | 0.074 | 0.094 | 0.091 | 0.089 | 0.087 | 0.085 | 0.084 | 0.082 | 0.080 | 0.079 | 0.077 | 0.076 | 0.073 | 0.072 |
| 20.5                          | 0.069 | 0.087 | 0.085 | 0.083 | 0.081 | 0.079 | 0.078 | 0.076 | 0.075 | 0.073 | 0.072 | 0.071 | 0.068 | 0.067 |
| 21.0                          | 0.065 | 0.081 | 0.079 | 0.078 | 0.076 | 0.074 | 0.073 | 0.071 | 0.070 | 0.068 | 0.067 | 0.066 | 0.064 | 0.063 |
| 21.5                          | 0.061 | 0.076 | 0.074 | 0.072 | 0.071 | 0.069 | 0.068 | 0.067 | 0.065 | 0.064 | 0.063 | 0.062 | 0.060 | 0.059 |
| 22.0                          | 0.057 | 0.071 | 0.070 | 0.068 | 0.067 | 0.065 | 0.064 | 0.063 | 0.062 | 0.061 | 0.059 | 0.058 | 0.056 | 0.056 |
| 22.5                          | 0.054 | 0.067 | 0.066 | 0.064 | 0.063 | 0.061 | 0.060 | 0.059 | 0.058 | 0.057 | 0.056 | 0.055 | 0.053 | 0.052 |
| 23.0                          | 0.051 | 0.063 | 0.062 | 0.060 | 0.059 | 0.058 | 0.057 | 0.056 | 0.055 | 0.054 | 0.053 | 0.052 | 0.050 | 0.049 |
| 23.5                          | 0.048 | 0.059 | 0.058 | 0.057 | 0.055 | 0.054 | 0.053 | 0.052 | 0.051 | 0.050 | 0.049 | 0.049 | 0.047 | 0.046 |
| 24.0                          | 0.045 | 0.056 | 0.054 | 0.053 | 0.052 | 0.051 | 0.050 | 0.049 | 0.048 | 0.047 | 0.047 | 0.046 | 0.044 | 0.044 |
| 24.5                          | 0.043 | 0.053 | 0.052 | 0.050 | 0.049 | 0.048 | 0.048 | 0.047 | 0.046 | 0.045 | 0.044 | 0.044 | 0.042 | 0.042 |
| 25.0                          | 0.041 | 0.050 | 0.049 | 0.048 | 0.047 | 0.046 | 0.045 | 0.044 | 0.043 | 0.043 | 0.042 | 0.041 | 0.040 | 0.039 |
| 25.5                          | 0.039 | 0.047 | 0.046 | 0.045 | 0.044 | 0.043 | 0.043 | 0.042 | 0.041 | 0.040 | 0.040 | 0.039 | 0.038 | 0.037 |
| 26.0                          | 0.037 | 0.045 | 0.044 | 0.043 | 0.042 | 0.041 | 0.041 | 0.040 | 0.039 | 0.039 | 0.038 | 0.037 | 0.036 | 0.036 |
| 26.5                          | 0.035 | 0.042 | 0.042 | 0.041 | 0.040 | 0.039 | 0.039 | 0.038 | 0.037 | 0.037 | 0.036 | 0.035 | 0.034 | 0.034 |
| 27.0                          | 0.033 | 0.040 | 0.039 | 0.038 | 0.038 | 0.037 | 0.036 | 0.036 | 0.035 | 0.034 | 0.034 | 0.033 | 0.032 | 0.032 |
| 27.5                          | 0.031 | 0.038 | 0.037 | 0.036 | 0.035 | 0.035 | 0.034 | 0.034 | 0.033 | 0.032 | 0.032 | 0.031 | 0.030 | 0.030 |
| 28.0                          | 0.029 | 0.035 | 0.034 | 0.034 | 0.033 | 0.032 | 0.032 | 0.031 | 0.031 | 0.030 | 0.030 | 0.029 | 0.028 | 0.028 |
| 28.5                          | 0.026 | 0.032 | 0.031 | 0.031 | 0.030 | 0.029 | 0.029 | 0.028 | 0.028 | 0.028 | 0.027 | 0.027 | 0.026 | 0.025 |
| 29.0                          | 0.024 | 0.029 | 0.028 | 0.028 | 0.027 | 0.027 | 0.026 | 0.026 | 0.025 | 0.025 | 0.025 | 0.024 | 0.023 | 0.023 |
| 29.5                          | 0.021 | 0.026 | 0.025 | 0.025 | 0.024 | 0.024 | 0.024 | 0.023 | 0.023 | 0.022 | 0.022 | 0.022 | 0.021 | 0.021 |
| 30.0                          | 0.019 | 0.023 | 0.023 | 0.022 | 0.022 | 0.021 | 0.021 | 0.021 | 0.020 | 0.020 | 0.020 | 0.019 | 0.019 | 0.019 |
| 30.5                          | 0.017 | 0.020 | 0.020 | 0.020 | 0.019 | 0.019 | 0.018 | 0.018 | 0.018 | 0.018 | 0.017 | 0.017 | 0.017 | 0.016 |
| 31.0                          | 0.015 | 0.018 | 0.017 | 0.017 | 0.017 | 0.016 | 0.016 | 0.016 | 0.016 | 0.015 | 0.015 | 0.015 | 0.015 | 0.014 |
| 31.5                          | 0.013 | 0.015 | 0.015 | 0.015 | 0.015 | 0.014 | 0.014 | 0.014 | 0.014 | 0.013 | 0.013 | 0.013 | 0.013 | 0.013 |
| 32.0                          | 0.011 | 0.014 | 0.013 | 0.013 | 0.013 | 0.013 | 0.012 | 0.012 | 0.012 | 0.012 | 0.012 | 0.012 | 0.011 | 0.011 |

Table 21-2: C<sub>t</sub> values, Load Optimized Mode LO1 (HWO)



### 21.3 Sound Curves, Load Optimized Mode LO1 (HWO)

| Sound Power Level at Hub Height   |  |
|-----------------------------------|--|
| Conditions for Sound Power Level: | Measurement standard IEC 61400-11 ed. 3<br>Maximum turbulence at hub height: 30%<br>Inflow angle (vertical): 0 ±2°<br>Air density: 1.225 kg/m <sup>3</sup> |
| Wind speed at hub height [m/s]    | Sound Power Level at Hub Height [dBA]<br>Load Optimized Mode LO1 (HWO)<br>(Blades with serrated trailing edge)   |
| 3                                 | 90.9   |
| 4                                 | 91.1   |
| 5                                 | 92.9   |
| 6                                 | 96.0   |
| 7                                 | 99.6   |
| 8                                 | 102.9  |
| 9                                 | 103.9  |
| 10                                | 103.9  |
| 11                                | 103.9  |
| 12                                | 103.9  |
| 13                                | 103.9  |
| 14                                | 103.9  |
| 15                                | 103.9  |
| 16                                | 103.9  |
| 17                                | 103.9  |
| 18                                | 103.9  |
| 19                                | 103.9  |
| 20                                | 103.9  |

*Table 21-3: Sound curves, Load Optimized Mode LO1 (HWO)*



## 22 Power Curves, Ct Values and Sound Curves, Load Optimized Mode LO2

**NOTE** The power curves and Ct values presented in Section 22 are only valid for low hub heights, i.e. hub heights ≤ 104 m.

### 22.1 Power Curves, Load Optimized Mode LO2

| Wind speed [m/s] | Air density [kg/m <sup>3</sup> ] |       |       |       |       |       |       |       |       |       |       |       |       |       |
|------------------|----------------------------------|-------|-------|-------|-------|-------|-------|-------|-------|-------|-------|-------|-------|-------|
|                  | 1.225                            | 0.950 | 0.975 | 1.000 | 1.025 | 1.050 | 1.075 | 1.100 | 1.125 | 1.150 | 1.175 | 1.200 | 1.250 | 1.275 |
| 3.0              | 55                               | 31    | 33    | 35    | 38    | 40    | 42    | 44    | 46    | 48    | 51    | 53    | 57    | 59    |
| 3.5              | 130                              | 89    | 93    | 97    | 100   | 104   | 108   | 111   | 115   | 119   | 122   | 126   | 133   | 137   |
| 4.0              | 220                              | 159   | 165   | 170   | 176   | 182   | 187   | 193   | 198   | 204   | 209   | 215   | 226   | 231   |
| 4.5              | 331                              | 245   | 253   | 260   | 268   | 276   | 284   | 292   | 299   | 307   | 315   | 323   | 338   | 346   |
| 5.0              | 471                              | 353   | 364   | 374   | 385   | 396   | 407   | 417   | 428   | 439   | 449   | 460   | 481   | 492   |
| 5.5              | 639                              | 483   | 497   | 511   | 526   | 540   | 554   | 568   | 582   | 596   | 610   | 624   | 653   | 667   |
| 6.0              | 841                              | 640   | 659   | 677   | 695   | 714   | 732   | 750   | 768   | 787   | 805   | 823   | 860   | 878   |
| 6.5              | 1080                             | 826   | 849   | 872   | 895   | 919   | 942   | 965   | 988   | 1011  | 1034  | 1057  | 1104  | 1127  |
| 7.0              | 1361                             | 1044  | 1073  | 1102  | 1131  | 1160  | 1189  | 1218  | 1247  | 1276  | 1304  | 1333  | 1390  | 1419  |
| 7.5              | 1682                             | 1294  | 1329  | 1365  | 1401  | 1436  | 1471  | 1507  | 1542  | 1577  | 1612  | 1647  | 1717  | 1752  |
| 8.0              | 2043                             | 1578  | 1620  | 1663  | 1706  | 1749  | 1791  | 1834  | 1876  | 1918  | 1960  | 2002  | 2085  | 2126  |
| 8.5              | 2435                             | 1886  | 1937  | 1987  | 2038  | 2088  | 2138  | 2188  | 2238  | 2288  | 2337  | 2386  | 2483  | 2532  |
| 9.0              | 2831                             | 2198  | 2257  | 2317  | 2377  | 2436  | 2494  | 2552  | 2609  | 2667  | 2722  | 2776  | 2883  | 2934  |
| 9.5              | 3175                             | 2494  | 2564  | 2633  | 2703  | 2773  | 2834  | 2896  | 2957  | 3019  | 3071  | 3123  | 3218  | 3262  |
| 10.0             | 3418                             | 2782  | 2855  | 2929  | 3003  | 3077  | 3134  | 3191  | 3248  | 3305  | 3343  | 3380  | 3444  | 3471  |
| 10.5             | 3538                             | 3042  | 3112  | 3182  | 3251  | 3321  | 3360  | 3400  | 3439  | 3479  | 3498  | 3518  | 3550  | 3561  |
| 11.0             | 3586                             | 3241  | 3296  | 3352  | 3408  | 3464  | 3487  | 3511  | 3535  | 3558  | 3568  | 3577  | 3590  | 3594  |
| 11.5             | 3598                             | 3409  | 3443  | 3478  | 3512  | 3546  | 3557  | 3568  | 3578  | 3589  | 3592  | 3595  | 3598  | 3599  |
| 12.0             | 3600                             | 3510  | 3528  | 3546  | 3563  | 3581  | 3585  | 3589  | 3593  | 3597  | 3598  | 3599  | 3600  | 3600  |
| 12.5             | 3600                             | 3563  | 3571  | 3579  | 3586  | 3594  | 3595  | 3597  | 3598  | 3599  | 3600  | 3600  | 3600  | 3600  |
| 13.0             | 3600                             | 3584  | 3587  | 3591  | 3594  | 3598  | 3598  | 3599  | 3600  | 3600  | 3600  | 3600  | 3600  | 3600  |
| 13.5             | 3600                             | 3588  | 3591  | 3593  | 3596  | 3598  | 3599  | 3599  | 3600  | 3600  | 3600  | 3600  | 3600  | 3600  |
| 14.0             | 3600                             | 3595  | 3596  | 3597  | 3598  | 3599  | 3599  | 3600  | 3600  | 3600  | 3600  | 3600  | 3600  | 3600  |
| 14.5             | 3600                             | 3598  | 3598  | 3599  | 3599  | 3600  | 3600  | 3600  | 3600  | 3600  | 3600  | 3600  | 3600  | 3600  |
| 15.0             | 3600                             | 3597  | 3598  | 3598  | 3599  | 3600  | 3600  | 3600  | 3600  | 3600  | 3600  | 3600  | 3600  | 3600  |
| 15.5             | 3600                             | 3598  | 3599  | 3599  | 3600  | 3600  | 3600  | 3600  | 3600  | 3600  | 3600  | 3600  | 3600  | 3600  |
| 16.0             | 3600                             | 3599  | 3599  | 3599  | 3600  | 3600  | 3600  | 3600  | 3600  | 3600  | 3600  | 3600  | 3600  | 3600  |
| 16.5             | 3600                             | 3599  | 3600  | 3600  | 3600  | 3600  | 3600  | 3600  | 3600  | 3600  | 3600  | 3600  | 3600  | 3600  |
| 17.0             | 3600                             | 3600  | 3600  | 3600  | 3600  | 3600  | 3600  | 3600  | 3600  | 3600  | 3600  | 3600  | 3600  | 3600  |
| 17.5             | 3600                             | 3600  | 3600  | 3600  | 3600  | 3600  | 3600  | 3600  | 3600  | 3600  | 3600  | 3600  | 3600  | 3600  |
| 18.0             | 3600                             | 3600  | 3600  | 3600  | 3600  | 3600  | 3600  | 3600  | 3600  | 3600  | 3600  | 3600  | 3600  | 3600  |
| 18.5             | 3600                             | 3600  | 3600  | 3600  | 3600  | 3600  | 3600  | 3600  | 3600  | 3600  | 3600  | 3600  | 3600  | 3600  |
| 19.0             | 3600                             | 3600  | 3600  | 3600  | 3600  | 3600  | 3600  | 3600  | 3600  | 3600  | 3600  | 3600  | 3600  | 3600  |
| 19.5             | 3600                             | 3600  | 3600  | 3600  | 3600  | 3600  | 3600  | 3600  | 3600  | 3600  | 3600  | 3600  | 3600  | 3600  |
| 20.0             | 3600                             | 3600  | 3600  | 3600  | 3600  | 3600  | 3600  | 3600  | 3600  | 3600  | 3600  | 3600  | 3600  | 3600  |
| 20.5             | 3600                             | 3600  | 3600  | 3600  | 3600  | 3600  | 3600  | 3600  | 3600  | 3600  | 3600  | 3600  | 3600  | 3600  |
| 21.0             | 3600                             | 3600  | 3600  | 3600  | 3600  | 3600  | 3600  | 3600  | 3600  | 3600  | 3600  | 3600  | 3600  | 3600  |
| 21.5             | 3600                             | 3600  | 3600  | 3600  | 3600  | 3600  | 3600  | 3600  | 3600  | 3600  | 3600  | 3600  | 3600  | 3600  |
| 22.0             | 3600                             | 3600  | 3600  | 3600  | 3600  | 3600  | 3600  | 3600  | 3600  | 3600  | 3600  | 3600  | 3600  | 3600  |
| 22.5             | 3600                             | 3600  | 3600  | 3600  | 3600  | 3600  | 3600  | 3600  | 3600  | 3600  | 3600  | 3600  | 3600  | 3600  |
| 23.0             | 3600                             | 3600  | 3600  | 3600  | 3600  | 3600  | 3600  | 3600  | 3600  | 3600  | 3600  | 3600  | 3600  | 3600  |
| 23.5             | 3600                             | 3600  | 3600  | 3600  | 3600  | 3600  | 3600  | 3600  | 3600  | 3600  | 3600  | 3600  | 3600  | 3600  |
| 24.0             | 3600                             | 3600  | 3600  | 3600  | 3600  | 3600  | 3600  | 3600  | 3600  | 3600  | 3600  | 3600  | 3600  | 3600  |
| 24.5             | 3600                             | 3600  | 3600  | 3600  | 3600  | 3600  | 3600  | 3600  | 3600  | 3600  | 3600  | 3600  | 3600  | 3600  |
| 25.0             | 3600                             | 3600  | 3600  | 3600  | 3600  | 3600  | 3600  | 3600  | 3600  | 3600  | 3600  | 3600  | 3600  | 3600  |
| 25.5             | 3600                             | 3600  | 3600  | 3600  | 3600  | 3600  | 3600  | 3600  | 3600  | 3600  | 3600  | 3600  | 3600  | 3600  |
| 26.0             | 3600                             | 3600  | 3600  | 3600  | 3600  | 3600  | 3600  | 3600  | 3600  | 3600  | 3600  | 3600  | 3600  | 3600  |
| 26.5             | 3600                             | 3600  | 3600  | 3600  | 3600  | 3600  | 3600  | 3600  | 3600  | 3600  | 3600  | 3600  | 3600  | 3600  |
| 27.0             | 3600                             | 3600  | 3600  | 3600  | 3600  | 3600  | 3600  | 3600  | 3600  | 3600  | 3600  | 3600  | 3600  | 3600  |

Table 22-1: Power curve, Load Optimized Mode LO2

**22.2 Ct Values, Load Optimized Mode LO2**

| Air density kg/m <sup>3</sup> |       |       |       |       |       |       |       |       |       |       |       |       |       |       |
|-------------------------------|-------|-------|-------|-------|-------|-------|-------|-------|-------|-------|-------|-------|-------|-------|
| Wind speed [m/s]              | 1.225 | 0.950 | 0.975 | 1.000 | 1.025 | 1.050 | 1.075 | 1.100 | 1.125 | 1.150 | 1.175 | 1.200 | 1.250 | 1.275 |
| 3.0                           | 0.873 | 0.878 | 0.877 | 0.877 | 0.876 | 0.876 | 0.876 | 0.875 | 0.875 | 0.874 | 0.874 | 0.874 | 0.873 | 0.873 |
| 3.5                           | 0.847 | 0.851 | 0.851 | 0.850 | 0.850 | 0.850 | 0.849 | 0.849 | 0.849 | 0.848 | 0.848 | 0.848 | 0.847 | 0.846 |
| 4.0                           | 0.845 | 0.854 | 0.853 | 0.851 | 0.850 | 0.848 | 0.848 | 0.848 | 0.847 | 0.847 | 0.847 | 0.846 | 0.845 | 0.845 |
| 4.5                           | 0.843 | 0.842 | 0.842 | 0.843 | 0.843 | 0.843 | 0.843 | 0.843 | 0.844 | 0.844 | 0.843 | 0.843 | 0.843 | 0.843 |
| 5.0                           | 0.844 | 0.848 | 0.848 | 0.848 | 0.847 | 0.847 | 0.847 | 0.846 | 0.846 | 0.846 | 0.845 | 0.845 | 0.844 | 0.843 |
| 5.5                           | 0.840 | 0.845 | 0.845 | 0.844 | 0.844 | 0.843 | 0.843 | 0.842 | 0.842 | 0.841 | 0.841 | 0.840 | 0.839 | 0.839 |
| 6.0                           | 0.834 | 0.840 | 0.840 | 0.839 | 0.839 | 0.838 | 0.838 | 0.837 | 0.836 | 0.836 | 0.835 | 0.835 | 0.834 | 0.833 |
| 6.5                           | 0.828 | 0.836 | 0.835 | 0.835 | 0.834 | 0.833 | 0.833 | 0.832 | 0.831 | 0.831 | 0.830 | 0.829 | 0.827 | 0.827 |
| 7.0                           | 0.821 | 0.831 | 0.830 | 0.829 | 0.828 | 0.828 | 0.827 | 0.826 | 0.825 | 0.824 | 0.823 | 0.822 | 0.820 | 0.819 |
| 7.5                           | 0.823 | 0.835 | 0.834 | 0.833 | 0.832 | 0.831 | 0.830 | 0.829 | 0.828 | 0.827 | 0.826 | 0.825 | 0.822 | 0.821 |
| 8.0                           | 0.824 | 0.837 | 0.836 | 0.835 | 0.834 | 0.833 | 0.832 | 0.831 | 0.829 | 0.828 | 0.827 | 0.826 | 0.823 | 0.822 |
| 8.5                           | 0.803 | 0.823 | 0.822 | 0.821 | 0.820 | 0.818 | 0.817 | 0.815 | 0.813 | 0.811 | 0.809 | 0.806 | 0.800 | 0.797 |
| 9.0                           | 0.748 | 0.785 | 0.783 | 0.781 | 0.779 | 0.777 | 0.773 | 0.770 | 0.766 | 0.762 | 0.758 | 0.753 | 0.743 | 0.737 |
| 9.5                           | 0.671 | 0.730 | 0.726 | 0.723 | 0.719 | 0.716 | 0.710 | 0.705 | 0.699 | 0.693 | 0.686 | 0.679 | 0.663 | 0.654 |
| 10.0                          | 0.585 | 0.670 | 0.665 | 0.660 | 0.654 | 0.649 | 0.641 | 0.633 | 0.625 | 0.616 | 0.606 | 0.596 | 0.574 | 0.563 |
| 10.5                          | 0.497 | 0.608 | 0.601 | 0.593 | 0.585 | 0.578 | 0.567 | 0.555 | 0.544 | 0.533 | 0.521 | 0.509 | 0.486 | 0.474 |
| 11.0                          | 0.421 | 0.541 | 0.531 | 0.521 | 0.511 | 0.502 | 0.490 | 0.478 | 0.466 | 0.454 | 0.443 | 0.432 | 0.411 | 0.401 |
| 11.5                          | 0.358 | 0.479 | 0.467 | 0.455 | 0.443 | 0.431 | 0.420 | 0.409 | 0.398 | 0.387 | 0.377 | 0.368 | 0.350 | 0.342 |
| 12.0                          | 0.309 | 0.416 | 0.404 | 0.393 | 0.381 | 0.370 | 0.360 | 0.351 | 0.341 | 0.332 | 0.324 | 0.316 | 0.302 | 0.295 |
| 12.5                          | 0.269 | 0.360 | 0.350 | 0.340 | 0.330 | 0.320 | 0.312 | 0.304 | 0.296 | 0.289 | 0.282 | 0.276 | 0.263 | 0.258 |
| 13.0                          | 0.237 | 0.314 | 0.305 | 0.297 | 0.288 | 0.280 | 0.273 | 0.267 | 0.260 | 0.253 | 0.248 | 0.242 | 0.232 | 0.227 |
| 13.5                          | 0.211 | 0.278 | 0.270 | 0.263 | 0.256 | 0.249 | 0.243 | 0.237 | 0.231 | 0.225 | 0.221 | 0.216 | 0.207 | 0.202 |
| 14.0                          | 0.188 | 0.246 | 0.240 | 0.234 | 0.227 | 0.221 | 0.216 | 0.211 | 0.206 | 0.201 | 0.197 | 0.192 | 0.184 | 0.181 |
| 14.5                          | 0.169 | 0.220 | 0.214 | 0.209 | 0.203 | 0.198 | 0.193 | 0.189 | 0.184 | 0.180 | 0.176 | 0.172 | 0.165 | 0.162 |
| 15.0                          | 0.151 | 0.196 | 0.191 | 0.187 | 0.182 | 0.177 | 0.173 | 0.169 | 0.165 | 0.161 | 0.158 | 0.155 | 0.149 | 0.146 |
| 15.5                          | 0.137 | 0.177 | 0.173 | 0.169 | 0.164 | 0.160 | 0.156 | 0.153 | 0.149 | 0.146 | 0.143 | 0.140 | 0.135 | 0.132 |
| 16.0                          | 0.125 | 0.161 | 0.157 | 0.153 | 0.149 | 0.145 | 0.142 | 0.139 | 0.136 | 0.133 | 0.130 | 0.127 | 0.122 | 0.120 |
| 16.5                          | 0.114 | 0.146 | 0.143 | 0.139 | 0.136 | 0.132 | 0.129 | 0.127 | 0.124 | 0.121 | 0.119 | 0.116 | 0.112 | 0.110 |
| 17.0                          | 0.104 | 0.134 | 0.130 | 0.127 | 0.124 | 0.121 | 0.119 | 0.116 | 0.113 | 0.111 | 0.109 | 0.107 | 0.103 | 0.101 |
| 17.5                          | 0.096 | 0.122 | 0.120 | 0.117 | 0.114 | 0.111 | 0.109 | 0.106 | 0.104 | 0.102 | 0.100 | 0.098 | 0.094 | 0.092 |
| 18.0                          | 0.088 | 0.113 | 0.110 | 0.107 | 0.105 | 0.102 | 0.100 | 0.098 | 0.096 | 0.094 | 0.092 | 0.090 | 0.087 | 0.085 |
| 18.5                          | 0.082 | 0.104 | 0.101 | 0.099 | 0.097 | 0.094 | 0.092 | 0.091 | 0.089 | 0.087 | 0.085 | 0.083 | 0.080 | 0.079 |
| 19.0                          | 0.076 | 0.096 | 0.093 | 0.091 | 0.089 | 0.087 | 0.085 | 0.083 | 0.082 | 0.080 | 0.078 | 0.077 | 0.074 | 0.073 |
| 19.5                          | 0.070 | 0.089 | 0.087 | 0.085 | 0.083 | 0.081 | 0.079 | 0.077 | 0.076 | 0.074 | 0.073 | 0.072 | 0.069 | 0.068 |
| 20.0                          | 0.065 | 0.082 | 0.081 | 0.079 | 0.077 | 0.075 | 0.074 | 0.072 | 0.071 | 0.069 | 0.068 | 0.067 | 0.064 | 0.063 |
| 20.5                          | 0.061 | 0.077 | 0.075 | 0.073 | 0.072 | 0.070 | 0.069 | 0.067 | 0.066 | 0.065 | 0.063 | 0.062 | 0.060 | 0.059 |
| 21.0                          | 0.057 | 0.072 | 0.070 | 0.069 | 0.067 | 0.066 | 0.064 | 0.063 | 0.062 | 0.061 | 0.059 | 0.058 | 0.056 | 0.055 |
| 21.5                          | 0.054 | 0.068 | 0.066 | 0.065 | 0.063 | 0.062 | 0.061 | 0.060 | 0.058 | 0.057 | 0.056 | 0.055 | 0.053 | 0.053 |
| 22.0                          | 0.051 | 0.064 | 0.062 | 0.061 | 0.059 | 0.058 | 0.057 | 0.056 | 0.055 | 0.054 | 0.053 | 0.052 | 0.050 | 0.049 |
| 22.5                          | 0.048 | 0.060 | 0.058 | 0.057 | 0.056 | 0.055 | 0.054 | 0.053 | 0.052 | 0.051 | 0.050 | 0.049 | 0.047 | 0.047 |
| 23.0                          | 0.045 | 0.056 | 0.055 | 0.054 | 0.052 | 0.051 | 0.050 | 0.049 | 0.048 | 0.048 | 0.047 | 0.046 | 0.044 | 0.044 |
| 23.5                          | 0.043 | 0.053 | 0.052 | 0.051 | 0.049 | 0.048 | 0.048 | 0.047 | 0.046 | 0.045 | 0.044 | 0.043 | 0.042 | 0.041 |
| 24.0                          | 0.040 | 0.050 | 0.049 | 0.048 | 0.047 | 0.046 | 0.045 | 0.044 | 0.043 | 0.043 | 0.042 | 0.041 | 0.040 | 0.039 |
| 24.5                          | 0.038 | 0.047 | 0.046 | 0.045 | 0.044 | 0.043 | 0.043 | 0.042 | 0.041 | 0.040 | 0.040 | 0.039 | 0.038 | 0.037 |
| 25.0                          | 0.036 | 0.045 | 0.044 | 0.043 | 0.042 | 0.041 | 0.040 | 0.040 | 0.039 | 0.038 | 0.038 | 0.037 | 0.036 | 0.035 |
| 25.5                          | 0.035 | 0.043 | 0.042 | 0.041 | 0.040 | 0.039 | 0.039 | 0.038 | 0.037 | 0.037 | 0.036 | 0.035 | 0.034 | 0.034 |
| 26.0                          | 0.033 | 0.040 | 0.040 | 0.039 | 0.038 | 0.037 | 0.037 | 0.036 | 0.035 | 0.035 | 0.034 | 0.034 | 0.033 | 0.032 |
| 26.5                          | 0.032 | 0.039 | 0.038 | 0.037 | 0.036 | 0.036 | 0.035 | 0.034 | 0.034 | 0.033 | 0.033 | 0.032 | 0.031 | 0.031 |
| 27.0                          | 0.030 | 0.037 | 0.036 | 0.035 | 0.035 | 0.034 | 0.033 | 0.033 | 0.032 | 0.032 | 0.031 | 0.031 | 0.030 | 0.029 |

Table 22-2: C<sub>t</sub> values, Load Optimized Mode LO2

### 22.3 Sound Curves, Load Optimized Mode LO2

| Sound Power Level at Hub Height   |   |
|-----------------------------------|---|
| Conditions for Sound Power Level: | Measurement standard IEC 61400-11 ed. 3<br>Maximum turbulence at hub height: 30%<br>Inflow angle (vertical): $0 \pm 2^\circ$<br>Air density: $1.225 \text{ kg/m}^3$ |
| Wind speed at hub height [m/s]    | Sound Power Level at Hub Height [dBA]<br>Load Optimized Mode LO2<br>(Blades with serrated trailing edge)  |
| 3                                 | 90.9  |
| 4                                 | 91.1  |
| 5                                 | 92.8  |
| 6                                 | 95.9  |
| 7                                 | 99.5  |
| 8                                 | 102.1   |
| 9                                 | 102.5   |
| 10                                | 102.5   |
| 11                                | 102.5   |
| 12                                | 102.5   |
| 13                                | 102.5   |
| 14                                | 102.5   |
| 15                                | 102.5   |
| 16                                | 102.5   |
| 17                                | 102.5   |
| 18                                | 102.5   |
| 19                                | 102.5   |
| 20                                | 102.5   |

Table 22-3: Sound curves, Load Optimized Mode LO2

**23 Power Curves, Ct Values and Sound Curves, Load Optimized Mode LO2 (HWO)**

**NOTE** The power curves and Ct values presented in Section 23 are only valid for low hub heights, i.e. hub heights ≤ 104 m.

**23.1 Power Curves, Load Optimized Mode LO2 (HWO)**

| Wind speed [m/s] | Air density [kg/m <sup>3</sup> ] |       |       |       |       |       |       |       |       |       |       |       |       |       |
|------------------|----------------------------------|-------|-------|-------|-------|-------|-------|-------|-------|-------|-------|-------|-------|-------|
|                  | 1.225                            | 0.950 | 0.975 | 1.000 | 1.025 | 1.050 | 1.075 | 1.100 | 1.125 | 1.150 | 1.175 | 1.200 | 1.250 | 1.275 |
| 3.0              | 55                               | 31    | 33    | 35    | 38    | 40    | 42    | 44    | 46    | 48    | 51    | 53    | 57    | 59    |
| 3.5              | 130                              | 89    | 93    | 97    | 100   | 104   | 108   | 111   | 115   | 119   | 122   | 126   | 133   | 137   |
| 4.0              | 220                              | 159   | 165   | 170   | 176   | 182   | 187   | 193   | 198   | 204   | 209   | 215   | 226   | 231   |
| 4.5              | 331                              | 245   | 253   | 260   | 268   | 276   | 284   | 292   | 299   | 307   | 315   | 323   | 338   | 346   |
| 5.0              | 471                              | 353   | 364   | 374   | 385   | 396   | 407   | 417   | 428   | 439   | 449   | 460   | 481   | 492   |
| 5.5              | 639                              | 483   | 497   | 511   | 526   | 540   | 554   | 568   | 582   | 596   | 610   | 624   | 653   | 667   |
| 6.0              | 841                              | 640   | 659   | 677   | 695   | 714   | 732   | 750   | 768   | 787   | 805   | 823   | 860   | 878   |
| 6.5              | 1080                             | 826   | 849   | 872   | 895   | 919   | 942   | 965   | 988   | 1011  | 1034  | 1057  | 1104  | 1127  |
| 7.0              | 1361                             | 1044  | 1073  | 1102  | 1131  | 1160  | 1189  | 1218  | 1247  | 1276  | 1304  | 1333  | 1390  | 1419  |
| 7.5              | 1682                             | 1294  | 1329  | 1365  | 1401  | 1436  | 1471  | 1507  | 1542  | 1577  | 1612  | 1647  | 1717  | 1752  |
| 8.0              | 2043                             | 1578  | 1620  | 1663  | 1706  | 1749  | 1791  | 1834  | 1876  | 1918  | 1960  | 2002  | 2085  | 2126  |
| 8.5              | 2435                             | 1886  | 1937  | 1987  | 2038  | 2088  | 2138  | 2188  | 2238  | 2288  | 2337  | 2386  | 2483  | 2532  |
| 9.0              | 2831                             | 2198  | 2257  | 2317  | 2377  | 2436  | 2494  | 2552  | 2609  | 2667  | 2722  | 2776  | 2883  | 2934  |
| 9.5              | 3175                             | 2494  | 2564  | 2633  | 2703  | 2773  | 2834  | 2896  | 2957  | 3019  | 3071  | 3123  | 3218  | 3262  |
| 10.0             | 3418                             | 2782  | 2855  | 2929  | 3003  | 3077  | 3134  | 3191  | 3248  | 3305  | 3343  | 3380  | 3444  | 3471  |
| 10.5             | 3538                             | 3042  | 3112  | 3182  | 3251  | 3321  | 3360  | 3400  | 3439  | 3479  | 3498  | 3518  | 3550  | 3561  |
| 11.0             | 3586                             | 3241  | 3296  | 3352  | 3408  | 3464  | 3487  | 3511  | 3535  | 3558  | 3568  | 3577  | 3590  | 3594  |
| 11.5             | 3598                             | 3409  | 3443  | 3478  | 3512  | 3546  | 3557  | 3568  | 3578  | 3589  | 3592  | 3595  | 3598  | 3599  |
| 12.0             | 3600                             | 3510  | 3528  | 3546  | 3563  | 3581  | 3585  | 3589  | 3593  | 3597  | 3598  | 3599  | 3600  | 3600  |
| 12.5             | 3600                             | 3563  | 3571  | 3579  | 3586  | 3594  | 3595  | 3597  | 3598  | 3599  | 3600  | 3600  | 3600  | 3600  |
| 13.0             | 3600                             | 3584  | 3587  | 3591  | 3594  | 3598  | 3598  | 3599  | 3600  | 3600  | 3600  | 3600  | 3600  | 3600  |
| 13.5             | 3600                             | 3588  | 3591  | 3593  | 3596  | 3598  | 3599  | 3599  | 3600  | 3600  | 3600  | 3600  | 3600  | 3600  |
| 14.0             | 3600                             | 3595  | 3596  | 3597  | 3598  | 3599  | 3599  | 3600  | 3600  | 3600  | 3600  | 3600  | 3600  | 3600  |
| 14.5             | 3600                             | 3598  | 3598  | 3599  | 3599  | 3600  | 3600  | 3600  | 3600  | 3600  | 3600  | 3600  | 3600  | 3600  |
| 15.0             | 3600                             | 3597  | 3598  | 3598  | 3599  | 3600  | 3600  | 3600  | 3600  | 3600  | 3600  | 3600  | 3600  | 3600  |
| 15.5             | 3600                             | 3598  | 3599  | 3599  | 3600  | 3600  | 3600  | 3600  | 3600  | 3600  | 3600  | 3600  | 3600  | 3600  |
| 16.0             | 3600                             | 3599  | 3599  | 3599  | 3600  | 3600  | 3600  | 3600  | 3600  | 3600  | 3600  | 3600  | 3600  | 3600  |
| 16.5             | 3600                             | 3599  | 3600  | 3600  | 3600  | 3600  | 3600  | 3600  | 3600  | 3600  | 3600  | 3600  | 3600  | 3600  |
| 17.0             | 3600                             | 3600  | 3600  | 3600  | 3600  | 3600  | 3600  | 3600  | 3600  | 3600  | 3600  | 3600  | 3600  | 3600  |
| 17.5             | 3600                             | 3600  | 3600  | 3600  | 3600  | 3600  | 3600  | 3600  | 3600  | 3600  | 3600  | 3600  | 3600  | 3600  |
| 18.0             | 3600                             | 3600  | 3600  | 3600  | 3600  | 3600  | 3600  | 3600  | 3600  | 3600  | 3600  | 3600  | 3600  | 3600  |
| 18.5             | 3600                             | 3600  | 3600  | 3600  | 3600  | 3600  | 3600  | 3600  | 3600  | 3600  | 3600  | 3600  | 3600  | 3600  |
| 19.0             | 3600                             | 3600  | 3600  | 3600  | 3600  | 3600  | 3600  | 3600  | 3600  | 3600  | 3600  | 3600  | 3600  | 3600  |
| 19.5             | 3600                             | 3600  | 3600  | 3600  | 3600  | 3600  | 3600  | 3600  | 3600  | 3600  | 3600  | 3600  | 3600  | 3600  |
| 20.0             | 3600                             | 3600  | 3600  | 3600  | 3600  | 3600  | 3600  | 3600  | 3600  | 3600  | 3600  | 3600  | 3600  | 3600  |
| 20.5             | 3600                             | 3600  | 3600  | 3600  | 3600  | 3600  | 3600  | 3600  | 3600  | 3600  | 3600  | 3600  | 3600  | 3600  |
| 21.0             | 3600                             | 3600  | 3600  | 3600  | 3600  | 3600  | 3600  | 3600  | 3600  | 3600  | 3600  | 3600  | 3600  | 3600  |
| 21.5             | 3600                             | 3600  | 3600  | 3600  | 3600  | 3600  | 3600  | 3600  | 3600  | 3600  | 3600  | 3600  | 3600  | 3600  |
| 22.0             | 3600                             | 3600  | 3600  | 3600  | 3600  | 3600  | 3600  | 3600  | 3600  | 3600  | 3600  | 3600  | 3600  | 3600  |
| 22.5             | 3600                             | 3600  | 3600  | 3600  | 3600  | 3600  | 3600  | 3600  | 3600  | 3600  | 3600  | 3600  | 3600  | 3600  |
| 23.0             | 3600                             | 3600  | 3600  | 3600  | 3600  | 3600  | 3600  | 3600  | 3600  | 3600  | 3600  | 3600  | 3600  | 3600  |
| 23.5             | 3600                             | 3600  | 3600  | 3600  | 3600  | 3600  | 3600  | 3600  | 3600  | 3600  | 3600  | 3600  | 3600  | 3600  |
| 24.0             | 3600                             | 3600  | 3600  | 3600  | 3600  | 3600  | 3600  | 3600  | 3600  | 3600  | 3600  | 3600  | 3600  | 3600  |
| 24.5             | 3600                             | 3600  | 3600  | 3600  | 3600  | 3600  | 3600  | 3600  | 3600  | 3600  | 3600  | 3600  | 3600  | 3600  |
| 25.0             | 3600                             | 3600  | 3600  | 3600  | 3600  | 3600  | 3600  | 3600  | 3600  | 3600  | 3600  | 3600  | 3600  | 3600  |
| 25.5             | 3600                             | 3600  | 3600  | 3600  | 3600  | 3600  | 3600  | 3600  | 3600  | 3600  | 3600  | 3600  | 3600  | 3600  |
| 26.0             | 3600                             | 3600  | 3600  | 3600  | 3600  | 3600  | 3600  | 3600  | 3600  | 3600  | 3600  | 3600  | 3600  | 3600  |
| 26.5             | 3595                             | 3595  | 3595  | 3595  | 3595  | 3595  | 3595  | 3595  | 3595  | 3595  | 3595  | 3595  | 3595  | 3595  |
| 27.0             | 3589                             | 3589  | 3589  | 3589  | 3589  | 3589  | 3589  | 3589  | 3589  | 3589  | 3589  | 3589  | 3589  | 3589  |
| 27.5             | 3542                             | 3542  | 3542  | 3542  | 3542  | 3542  | 3542  | 3542  | 3542  | 3542  | 3542  | 3542  | 3542  | 3542  |
| 28.0             | 3439                             | 3440  | 3440  | 3440  | 3440  | 3440  | 3440  | 3440  | 3440  | 3440  | 3439  | 3439  | 3439  | 3439  |

| <b>Air density [kg/m<sup>3</sup>]</b> |              |              |              |              |              |              |              |              |              |              |              |              |              |              |
|---------------------------------------|--------------|--------------|--------------|--------------|--------------|--------------|--------------|--------------|--------------|--------------|--------------|--------------|--------------|--------------|
| <b>Wind speed [m/s]</b>               | <b>1.225</b> | <b>0.950</b> | <b>0.975</b> | <b>1.000</b> | <b>1.025</b> | <b>1.050</b> | <b>1.075</b> | <b>1.100</b> | <b>1.125</b> | <b>1.150</b> | <b>1.175</b> | <b>1.200</b> | <b>1.250</b> | <b>1.275</b> |
| <b>28.5</b>                           | <b>3270</b>  | 3270         | 3270         | 3270         | 3270         | 3270         | 3270         | 3270         | 3270         | 3270         | 3270         | 3270         | 3270         | 3270         |
| <b>29.0</b>                           | <b>3049</b>  | 3049         | 3049         | 3049         | 3049         | 3049         | 3049         | 3049         | 3049         | 3049         | 3049         | 3049         | 3049         | 3049         |
| <b>29.5</b>                           | <b>2806</b>  | 2806         | 2806         | 2806         | 2806         | 2806         | 2806         | 2806         | 2806         | 2806         | 2806         | 2806         | 2806         | 2806         |
| <b>30.0</b>                           | <b>2565</b>  | 2565         | 2565         | 2565         | 2565         | 2565         | 2565         | 2565         | 2565         | 2565         | 2565         | 2565         | 2565         | 2565         |
| <b>30.5</b>                           | <b>2324</b>  | 2324         | 2324         | 2324         | 2325         | 2325         | 2325         | 2325         | 2325         | 2325         | 2324         | 2324         | 2324         | 2324         |
| <b>31.0</b>                           | <b>2090</b>  | 2090         | 2090         | 2090         | 2090         | 2090         | 2090         | 2090         | 2090         | 2090         | 2090         | 2090         | 2090         | 2090         |
| <b>31.5</b>                           | <b>1884</b>  | 1884         | 1884         | 1884         | 1884         | 1884         | 1884         | 1884         | 1884         | 1884         | 1884         | 1884         | 1884         | 1884         |
| <b>32.0</b>                           | <b>1732</b>  | 1732         | 1732         | 1732         | 1732         | 1732         | 1732         | 1732         | 1732         | 1732         | 1732         | 1732         | 1732         | 1732         |

*Table 23-1: Power curve, Load Optimized Mode LO2 (HWO)*

**23.2 Ct Values, Load Optimized Mode LO2 (HWO)**

| Air density kg/m <sup>3</sup> |       |       |       |       |       |       |       |       |       |       |       |       |       |       |
|-------------------------------|-------|-------|-------|-------|-------|-------|-------|-------|-------|-------|-------|-------|-------|-------|
| Wind speed [m/s]              | 1.225 | 0.950 | 0.975 | 1.000 | 1.025 | 1.050 | 1.075 | 1.100 | 1.125 | 1.150 | 1.175 | 1.200 | 1.250 | 1.275 |
| 3.0                           | 0.873 | 0.878 | 0.877 | 0.877 | 0.876 | 0.876 | 0.876 | 0.875 | 0.875 | 0.874 | 0.874 | 0.874 | 0.873 | 0.873 |
| 3.5                           | 0.847 | 0.851 | 0.851 | 0.850 | 0.850 | 0.850 | 0.849 | 0.849 | 0.849 | 0.848 | 0.848 | 0.848 | 0.847 | 0.846 |
| 4.0                           | 0.845 | 0.854 | 0.853 | 0.851 | 0.850 | 0.848 | 0.848 | 0.848 | 0.847 | 0.847 | 0.847 | 0.846 | 0.845 | 0.845 |
| 4.5                           | 0.843 | 0.842 | 0.842 | 0.843 | 0.843 | 0.843 | 0.843 | 0.843 | 0.844 | 0.844 | 0.843 | 0.843 | 0.843 | 0.843 |
| 5.0                           | 0.844 | 0.848 | 0.848 | 0.848 | 0.847 | 0.847 | 0.847 | 0.846 | 0.846 | 0.846 | 0.845 | 0.845 | 0.844 | 0.843 |
| 5.5                           | 0.840 | 0.845 | 0.845 | 0.844 | 0.844 | 0.843 | 0.843 | 0.842 | 0.842 | 0.841 | 0.841 | 0.840 | 0.839 | 0.839 |
| 6.0                           | 0.834 | 0.840 | 0.840 | 0.839 | 0.839 | 0.838 | 0.838 | 0.837 | 0.836 | 0.836 | 0.835 | 0.835 | 0.834 | 0.833 |
| 6.5                           | 0.828 | 0.836 | 0.835 | 0.835 | 0.834 | 0.833 | 0.833 | 0.832 | 0.831 | 0.831 | 0.830 | 0.829 | 0.827 | 0.827 |
| 7.0                           | 0.821 | 0.831 | 0.830 | 0.829 | 0.828 | 0.828 | 0.827 | 0.826 | 0.825 | 0.824 | 0.823 | 0.822 | 0.820 | 0.819 |
| 7.5                           | 0.823 | 0.835 | 0.834 | 0.833 | 0.832 | 0.831 | 0.830 | 0.829 | 0.828 | 0.827 | 0.826 | 0.825 | 0.822 | 0.821 |
| 8.0                           | 0.824 | 0.837 | 0.836 | 0.835 | 0.834 | 0.833 | 0.832 | 0.831 | 0.829 | 0.828 | 0.827 | 0.826 | 0.823 | 0.822 |
| 8.5                           | 0.803 | 0.823 | 0.822 | 0.821 | 0.820 | 0.818 | 0.817 | 0.815 | 0.813 | 0.811 | 0.809 | 0.806 | 0.800 | 0.797 |
| 9.0                           | 0.748 | 0.785 | 0.783 | 0.781 | 0.779 | 0.777 | 0.773 | 0.770 | 0.766 | 0.762 | 0.758 | 0.753 | 0.743 | 0.737 |
| 9.5                           | 0.671 | 0.730 | 0.726 | 0.723 | 0.719 | 0.716 | 0.710 | 0.705 | 0.699 | 0.693 | 0.686 | 0.679 | 0.663 | 0.654 |
| 10.0                          | 0.585 | 0.670 | 0.665 | 0.660 | 0.654 | 0.649 | 0.641 | 0.633 | 0.625 | 0.616 | 0.606 | 0.596 | 0.574 | 0.563 |
| 10.5                          | 0.497 | 0.608 | 0.601 | 0.593 | 0.585 | 0.578 | 0.567 | 0.555 | 0.544 | 0.533 | 0.521 | 0.509 | 0.486 | 0.474 |
| 11.0                          | 0.421 | 0.541 | 0.531 | 0.521 | 0.511 | 0.502 | 0.490 | 0.478 | 0.466 | 0.454 | 0.443 | 0.432 | 0.411 | 0.401 |
| 11.5                          | 0.358 | 0.479 | 0.467 | 0.455 | 0.443 | 0.431 | 0.420 | 0.409 | 0.398 | 0.387 | 0.377 | 0.368 | 0.350 | 0.342 |
| 12.0                          | 0.309 | 0.416 | 0.404 | 0.393 | 0.381 | 0.370 | 0.360 | 0.351 | 0.341 | 0.332 | 0.324 | 0.316 | 0.302 | 0.295 |
| 12.5                          | 0.269 | 0.360 | 0.350 | 0.340 | 0.330 | 0.320 | 0.312 | 0.304 | 0.296 | 0.289 | 0.282 | 0.276 | 0.263 | 0.258 |
| 13.0                          | 0.237 | 0.314 | 0.305 | 0.297 | 0.288 | 0.280 | 0.273 | 0.267 | 0.260 | 0.253 | 0.248 | 0.242 | 0.232 | 0.227 |
| 13.5                          | 0.211 | 0.278 | 0.270 | 0.263 | 0.256 | 0.249 | 0.243 | 0.237 | 0.231 | 0.225 | 0.221 | 0.216 | 0.207 | 0.202 |
| 14.0                          | 0.188 | 0.246 | 0.240 | 0.234 | 0.227 | 0.221 | 0.216 | 0.211 | 0.206 | 0.201 | 0.197 | 0.192 | 0.184 | 0.181 |
| 14.5                          | 0.169 | 0.220 | 0.214 | 0.209 | 0.203 | 0.198 | 0.193 | 0.189 | 0.184 | 0.180 | 0.176 | 0.172 | 0.165 | 0.162 |
| 15.0                          | 0.151 | 0.196 | 0.191 | 0.187 | 0.182 | 0.177 | 0.173 | 0.169 | 0.165 | 0.161 | 0.158 | 0.155 | 0.149 | 0.146 |
| 15.5                          | 0.137 | 0.177 | 0.173 | 0.169 | 0.164 | 0.160 | 0.156 | 0.153 | 0.149 | 0.146 | 0.143 | 0.140 | 0.135 | 0.132 |
| 16.0                          | 0.125 | 0.161 | 0.157 | 0.153 | 0.149 | 0.145 | 0.142 | 0.139 | 0.136 | 0.133 | 0.130 | 0.127 | 0.122 | 0.120 |
| 16.5                          | 0.114 | 0.146 | 0.143 | 0.139 | 0.136 | 0.132 | 0.129 | 0.127 | 0.124 | 0.121 | 0.119 | 0.116 | 0.112 | 0.110 |
| 17.0                          | 0.104 | 0.134 | 0.130 | 0.127 | 0.124 | 0.121 | 0.119 | 0.116 | 0.113 | 0.111 | 0.109 | 0.107 | 0.103 | 0.101 |
| 17.5                          | 0.096 | 0.122 | 0.120 | 0.117 | 0.114 | 0.111 | 0.109 | 0.106 | 0.104 | 0.102 | 0.100 | 0.098 | 0.094 | 0.092 |
| 18.0                          | 0.088 | 0.113 | 0.110 | 0.107 | 0.105 | 0.102 | 0.100 | 0.098 | 0.096 | 0.094 | 0.092 | 0.090 | 0.087 | 0.085 |
| 18.5                          | 0.082 | 0.104 | 0.101 | 0.099 | 0.097 | 0.094 | 0.092 | 0.091 | 0.089 | 0.087 | 0.085 | 0.083 | 0.080 | 0.079 |
| 19.0                          | 0.076 | 0.096 | 0.093 | 0.091 | 0.089 | 0.087 | 0.085 | 0.083 | 0.082 | 0.080 | 0.078 | 0.077 | 0.074 | 0.073 |
| 19.5                          | 0.070 | 0.089 | 0.087 | 0.085 | 0.083 | 0.081 | 0.079 | 0.077 | 0.076 | 0.074 | 0.073 | 0.072 | 0.069 | 0.068 |
| 20.0                          | 0.065 | 0.082 | 0.081 | 0.079 | 0.077 | 0.075 | 0.074 | 0.072 | 0.071 | 0.069 | 0.068 | 0.067 | 0.064 | 0.063 |
| 20.5                          | 0.061 | 0.077 | 0.075 | 0.073 | 0.072 | 0.070 | 0.069 | 0.067 | 0.066 | 0.065 | 0.063 | 0.062 | 0.060 | 0.059 |
| 21.0                          | 0.057 | 0.072 | 0.070 | 0.069 | 0.067 | 0.066 | 0.064 | 0.063 | 0.062 | 0.061 | 0.059 | 0.058 | 0.056 | 0.055 |
| 21.5                          | 0.054 | 0.068 | 0.066 | 0.065 | 0.063 | 0.062 | 0.061 | 0.060 | 0.058 | 0.057 | 0.056 | 0.055 | 0.053 | 0.053 |
| 22.0                          | 0.051 | 0.064 | 0.062 | 0.061 | 0.059 | 0.058 | 0.057 | 0.056 | 0.055 | 0.054 | 0.053 | 0.052 | 0.050 | 0.049 |
| 22.5                          | 0.048 | 0.060 | 0.058 | 0.057 | 0.056 | 0.055 | 0.054 | 0.053 | 0.052 | 0.051 | 0.050 | 0.049 | 0.047 | 0.047 |
| 23.0                          | 0.045 | 0.056 | 0.055 | 0.054 | 0.052 | 0.051 | 0.050 | 0.049 | 0.048 | 0.048 | 0.047 | 0.046 | 0.044 | 0.044 |
| 23.5                          | 0.043 | 0.053 | 0.052 | 0.051 | 0.049 | 0.048 | 0.048 | 0.047 | 0.046 | 0.045 | 0.044 | 0.043 | 0.042 | 0.041 |
| 24.0                          | 0.040 | 0.050 | 0.049 | 0.048 | 0.047 | 0.046 | 0.045 | 0.044 | 0.043 | 0.043 | 0.042 | 0.041 | 0.040 | 0.039 |
| 24.5                          | 0.038 | 0.047 | 0.046 | 0.045 | 0.044 | 0.043 | 0.043 | 0.042 | 0.041 | 0.040 | 0.040 | 0.039 | 0.038 | 0.037 |
| 25.0                          | 0.036 | 0.045 | 0.044 | 0.043 | 0.042 | 0.041 | 0.040 | 0.040 | 0.039 | 0.038 | 0.038 | 0.037 | 0.036 | 0.035 |
| 25.5                          | 0.035 | 0.043 | 0.042 | 0.041 | 0.040 | 0.039 | 0.039 | 0.038 | 0.037 | 0.037 | 0.036 | 0.035 | 0.034 | 0.034 |
| 26.0                          | 0.033 | 0.040 | 0.040 | 0.039 | 0.038 | 0.037 | 0.037 | 0.036 | 0.035 | 0.035 | 0.034 | 0.034 | 0.033 | 0.032 |
| 26.5                          | 0.032 | 0.038 | 0.038 | 0.037 | 0.036 | 0.035 | 0.035 | 0.034 | 0.034 | 0.033 | 0.033 | 0.032 | 0.031 | 0.031 |
| 27.0                          | 0.030 | 0.036 | 0.036 | 0.035 | 0.034 | 0.034 | 0.033 | 0.033 | 0.032 | 0.031 | 0.031 | 0.030 | 0.030 | 0.029 |
| 27.5                          | 0.028 | 0.034 | 0.034 | 0.033 | 0.032 | 0.032 | 0.031 | 0.031 | 0.030 | 0.029 | 0.029 | 0.029 | 0.028 | 0.027 |
| 28.0                          | 0.026 | 0.032 | 0.031 | 0.031 | 0.030 | 0.029 | 0.029 | 0.028 | 0.028 | 0.027 | 0.027 | 0.026 | 0.026 | 0.025 |
| 28.5                          | 0.024 | 0.029 | 0.028 | 0.028 | 0.027 | 0.027 | 0.026 | 0.026 | 0.025 | 0.025 | 0.025 | 0.024 | 0.023 | 0.023 |
| 29.0                          | 0.021 | 0.026 | 0.025 | 0.025 | 0.024 | 0.024 | 0.024 | 0.023 | 0.023 | 0.022 | 0.022 | 0.022 | 0.021 | 0.021 |
| 29.5                          | 0.019 | 0.023 | 0.023 | 0.022 | 0.022 | 0.021 | 0.021 | 0.021 | 0.020 | 0.020 | 0.020 | 0.019 | 0.019 | 0.019 |
| 30.0                          | 0.017 | 0.020 | 0.020 | 0.020 | 0.019 | 0.019 | 0.018 | 0.018 | 0.018 | 0.018 | 0.017 | 0.017 | 0.017 | 0.016 |
| 30.5                          | 0.015 | 0.018 | 0.017 | 0.017 | 0.017 | 0.016 | 0.016 | 0.016 | 0.016 | 0.015 | 0.015 | 0.015 | 0.015 | 0.014 |
| 31.0                          | 0.013 | 0.015 | 0.015 | 0.015 | 0.015 | 0.014 | 0.014 | 0.014 | 0.014 | 0.013 | 0.013 | 0.013 | 0.013 | 0.013 |
| 31.5                          | 0.011 | 0.014 | 0.013 | 0.013 | 0.013 | 0.013 | 0.012 | 0.012 | 0.012 | 0.012 | 0.012 | 0.012 | 0.011 | 0.011 |
| 32.0                          | 0.010 | 0.012 | 0.012 | 0.012 | 0.012 | 0.011 | 0.011 | 0.011 | 0.011 | 0.011 | 0.010 | 0.010 | 0.010 | 0.010 |

Table 23-2: C<sub>t</sub> values, Load Optimized Mode LO2 (HWO)



### 23.3 Sound Curves, Load Optimized Mode LO2 (HWO)

| Sound Power Level at Hub Height   |  |
|-----------------------------------|--|
| Conditions for Sound Power Level: | Measurement standard IEC 61400-11 ed. 3<br>Maximum turbulence at hub height: 30%<br>Inflow angle (vertical): 0 ±2°<br>Air density: 1.225 kg/m <sup>3</sup> |
| Wind speed at hub height [m/s]    | Sound Power Level at Hub Height [dBA]<br>Load Optimized Mode LO2 (HWO)<br>(Blades with serrated trailing edge)   |
| 3                                 | 90.9   |
| 4                                 | 91.1   |
| 5                                 | 92.8   |
| 6                                 | 95.9   |
| 7                                 | 99.5   |
| 8                                 | 102.1  |
| 9                                 | 102.5  |
| 10                                | 102.5  |
| 11                                | 102.5  |
| 12                                | 102.5  |
| 13                                | 102.5  |
| 14                                | 102.5  |
| 15                                | 102.5  |
| 16                                | 102.5  |
| 17                                | 102.5  |
| 18                                | 102.5  |
| 19                                | 102.5  |
| 20                                | 102.5  |

*Table 23-3: Sound curves, Load Optimized Mode LO2 (HWO)*