

Note*

Simple Support - Standard Embedment Length
60 Degrees
1.3m (1335mm)
1.5m (1524mm)
1.7m (1728mm)
2m (2032mm)
2.5m (2530mm)
2.8m (2835mm)
3m (3049mm)

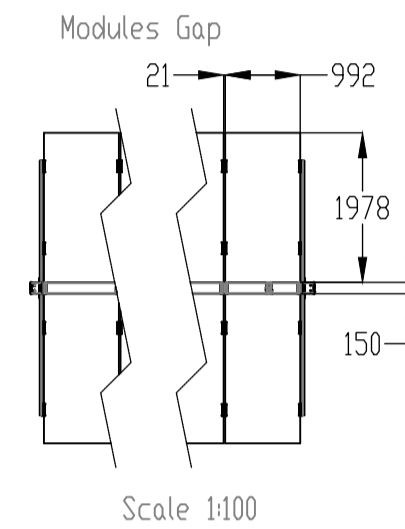

SAFETRACK HORIZON - DETTAGLI COSTRUTTIVI_Scala 1 : 50

STUDIO ALCHEMIST
Ing. Stefano Floris - Arch. Cinzia Nieddu

Via Isola San Pietro 3 - 09126 Cagliari (CA)
Via Semplicio Spano 10 - 07026 Olbia (OT)

stefano.floris@studioalchemist.it
cinzia.nieddu@studioalchemist.it

www.studioalchemist.it

COMUNE DI LAERRU (SS)

OGGETTO
REALIZZAZIONE DI IMPIANTO AGRIVOLTAICO A TERRA DA 39,58 MW IN IMMISSIONE - SU TRACKER DI TIPO AD INSEGUIMENTO MONOASSIALE "LAERRU"

COMMITTENTE
ENERGYLAERRU SRL P.IVA 02954120909
Via Semplicio Spano 10 - 07026 Olbia (SS)

PROGETTO DEFINITIVO

ELABORATO	NUMERO ELABORATO
DETTAGLI COSTRUTTIVI - STRUTTURA FOTOVOLTAICA	AU 09
	SCALA: VARIE
	DATA: LUGLIO 2023

3	Terza emissione		
2	Seconda emissione		
1	Prima emissione	Arch. Valentina Madeddu	Arch. Chiara Martis
			Ing. S. Floris

REV.	DATA	DESCRIZIONE	REDATTO	CONTROLLATO	APPROVATO

CODICE COMMESSA	NOME FILE	FASE PROGETTUALE	REV.
		DEF	IMPIANTI 00

STUDIO ALCHEMIST: Ing. Stefano Floris Arch. Cinzia Nieddu COLLABORATORI: Arch. Chiara Martis Arch. Valentina Madeddu Arch. Michela Melis Arch. Martina Sias Arch. Luigi Mereu Arch. Matteo De Curtis Geol. Mario Strinna	PROGETTISTA - TIMBRO E FIRMA 	PROGETTISTA - TIMBRO E FIRMA
--	---	---

www.jinkosolar.com

Tiger Neo N-type
72HL4-BDV
550-570 Watt
BIFACIAL MODULE WITH DUAL GLASS

N-Type

Positive power tolerance of 0~+3%

IEC61215(2016), IEC61730(2016)
ISO9001:2015: Quality Management System
ISO14001:2015: Environment Management System
ISO45001:2018
Occupational health and safety management systems

Key Features

SMBB Technology
Better light trapping and current collection to improve module power output and reliability.

PID Resistance
Excellent Anti-PID performance guarantee via optimized mass-production process and materials control.

Higher Power Output
Module power increases 5-25% generally, bringing significantly lower LCOE and higher IRR.

HOT 2.0
The N-type module with Hot 2.0 technology has better reliability and lower LID/LETID.

Enhanced Mechanical Load
Certified to withstand: wind load (2400 Pascal) and snow load (5400 Pascal).

LINEAR PERFORMANCE WARRANTY

12 Year Product Warranty

30 Year Linear Power Warranty

0.40% Annual Degradation Over 30 years

Engineering Drawings

Electrical Performance & Temperature Dependence

Mechanical Characteristics

Cell Type	N-type Mono-crystalline	
No. of cells	144 (2x72)	
Dimensions	2278x1134x30mm (89.69x44.65x1.18 inch)	
Weight	32 kg (70.55 lbs)	
Front Glass	2.0mm, Anti-Reflection Coating	
Back Glass	2.0mm, Heat Strengthened Glass	
Frame	Anodized Aluminum Alloy	
Junction Box	IP68 Rated	
Output Cables	TUV 1x4.0mm (+): 400mm, (-): 200mm or Customized Length	

Packaging Configuration

[Two pallets = One stack]
36pcs/pallets, 72pcs/stack, 720pcs/40HQ Container

SPECIFICATIONS

Module Type	JKM550N-72HL4-BDV		JKM555N-72HL4-BDV		JKM560N-72HL4-BDV		JKM565N-72HL4-BDV		JKM570N-72HL4-BDV	
	STC	NOCT	STC	NOCT	STC	NOCT	STC	NOCT	STC	NOCT
Maximum Power (Pmax)	550Wp	414Wp	555Wp	417Wp	560Wp	421Wp	565Wp	425Wp	570Wp	429Wp
Maximum Power Voltage (Vmp)	41.58V	39.13V	41.77V	39.26V	41.95V	39.39V	42.14V	39.52V	42.29V	39.65V
Maximum Power Current (Imp)	13.23A	10.57A	13.29A	10.63A	13.35A	10.69A	13.41A	10.75A	13.48A	10.81A
Open-circuit Voltage (Voc)	50.27V	47.75V	50.47V	47.94V	50.67V	48.13V	50.87V	48.32V	51.07V	48.51V
Short-circuit Current (Isc)	14.07A	11.31A	14.07A	11.36A	14.13A	11.41A	14.19A	11.46A	14.25A	11.50A
Module Efficiency STC (%)	21.29%		21.48%		21.68%		21.87%		22.07%	
Operating Temperature(°C)	-40°C~+85°C									
Maximum system voltage	1500VDC (IEC)									
Maximum series fuse rating	30A									
Power tolerance	0~+3%									
Temperature coefficients of Pmax	-0.30%/°C									
Temperature coefficients of Voc	-0.25%/°C									
Temperature coefficients of Isc	0.046%/°C									
Nominal operating cell temperature (NOCT)	45±2°C									
Refer. Bifacial Factor	80±5%									

BIFACIAL OUTPUT-REAR SIDE POWER GAIN

	5%	15%	25%
Maximum Power (Pmax)	578Wp	633Wp	688Wp
Module Efficiency STC (%)	22.36%	24.48%	26.61%
Maximum Power (Pmax)	583Wp	638Wp	694Wp
Module Efficiency STC (%)	22.54%	24.71%	26.86%
Maximum Power (Pmax)	588Wp	644Wp	700Wp
Module Efficiency STC (%)	22.72%	24.93%	27.10%
Maximum Power (Pmax)	593Wp	650Wp	706Wp
Module Efficiency STC (%)	22.97%	25.15%	27.34%
Maximum Power (Pmax)	599Wp	656Wp	713Wp
Module Efficiency STC (%)	23.17%	25.37%	27.58%

*STC: Irradiance 1000W/m² Cell Temperature 25°C AM=1.5
NOCT: Irradiance 800W/m² Ambient Temperature 20°C AM=1.5 Wind Speed 1m/s

©2021 Jinko Solar Co., Ltd. All rights reserved. Specifications included in this datasheet are subject to change without notice. JKM550-570N-72HL4-BDV-F2-EN (IEC 2016)

SCHEDE TECNICHE - PANNELLO FOTOVOLTAICO