

S.S. 100 "di Gioia del Colle"
COMPLETAMENTO FUNZIONALE E MESSA IN SICUREZZA DELLA S.S. 100, TRA I KM 44+500 E 52+600 (SAN BASILIO) CON SEZIONE DI TIPO B.

PROGETTO DEFINITIVO

COD. BA291

RESPONSABILE INTEGRAZIONE SPECIALISTICA
Ing. Alessandro Aliotta – Ordine degli Ingegneri di Genova n° 7995 A

IL PROGETTISTA E COORDINATORE DELLA SICUREZZA IN FASE DI PROGETTAZIONE
Ing. Vito Capotorto – Ordine degli Ingegneri di Taranto n° 1080

IL GEOLOGO
Dott. Geol. Mario Stani
(Ordine dei Geologi della Puglia n° 279)

L'ARCHEOLOGO: Dott.ssa Paola Innuzziello
Elenco MIC n. 2571 – archeologo di 1° fascia ai sensi del D.M. 244/2019

IL RESPONSABILE DEL PROCEDIMENTO
Ing. Alberto SANCHIRICO

Progettisti



DIRETTORE TECNICO
Prof. Ing. Andrea Del Grosso



DIRETTORE TECNICO
Ing. Franz Pacher



DIRETTORE TECNICO
Ing. Primo STASI



Ing. Tommaso DI BARI
Ing. Vito CAPOTORTO



DIRETTORE TECNICO
LAND Italia Srl
Arch. Andreas KIPAR

PROGETTO STRADALE

Strade locali a destinazione particolare Est - Ovest
Album delle sezioni trasversali Strada locale - Ovest n°2

CODICE PROGETTO			NOME FILE	REVISIONE	SCALA:
PROGETTO	LIV. PROG.	ANNO	S01PS02TRASZ01_A		
STBA0291	D	23	CODICE ELAB. S01PS02TRASZ01	A	1:200
A	Prima emissione	Giugno 2023	F. Bolettieri	V. Capotorto	T. Di Bari
REV.	DESCRIZIONE	DATA	REDATTO	VERIFICATO	APPROVATO

KEY-MAP

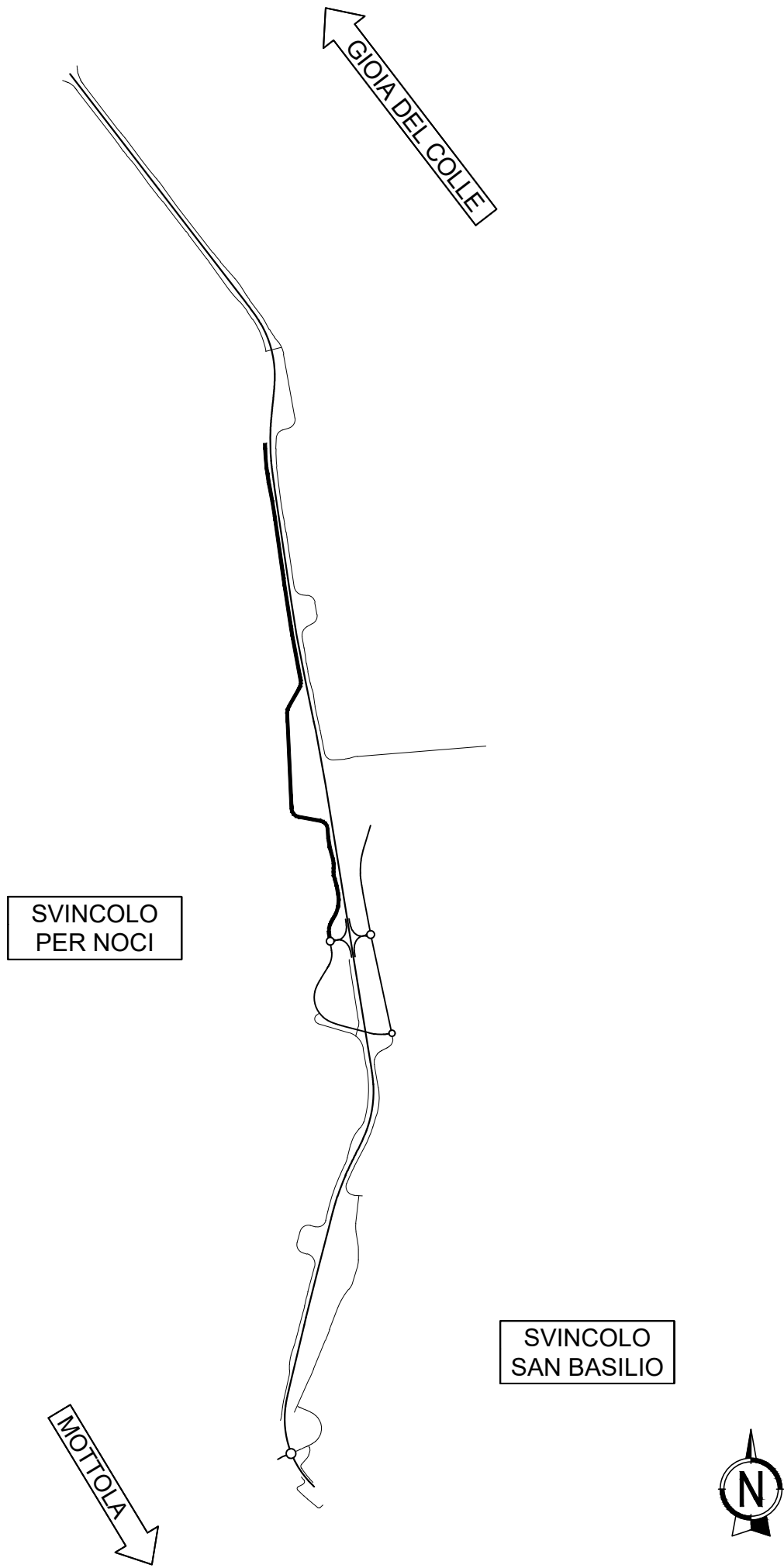

SCAVI E BONIFICHE	
SCOTICO	8.09 m
BONIFICA	4.85 mq

RILEVATI	
RILEVATO	0.04 mq
TERRENO VEGETALE	1.11 m

SOVRASTRUTTURA STRADALE	
STRATO DI USURA	6.50 m
STRATO DI BINDER	6.50 m
STRATO DI BASE	6.50 m
STRATO DI FONDAZIONE	1.11 mq

SEZIONE N. : 46
 Qt. prog. : 325.90
 Progr. Km : 0+900.000

Scala 1:200

Qt. rif. 313.000

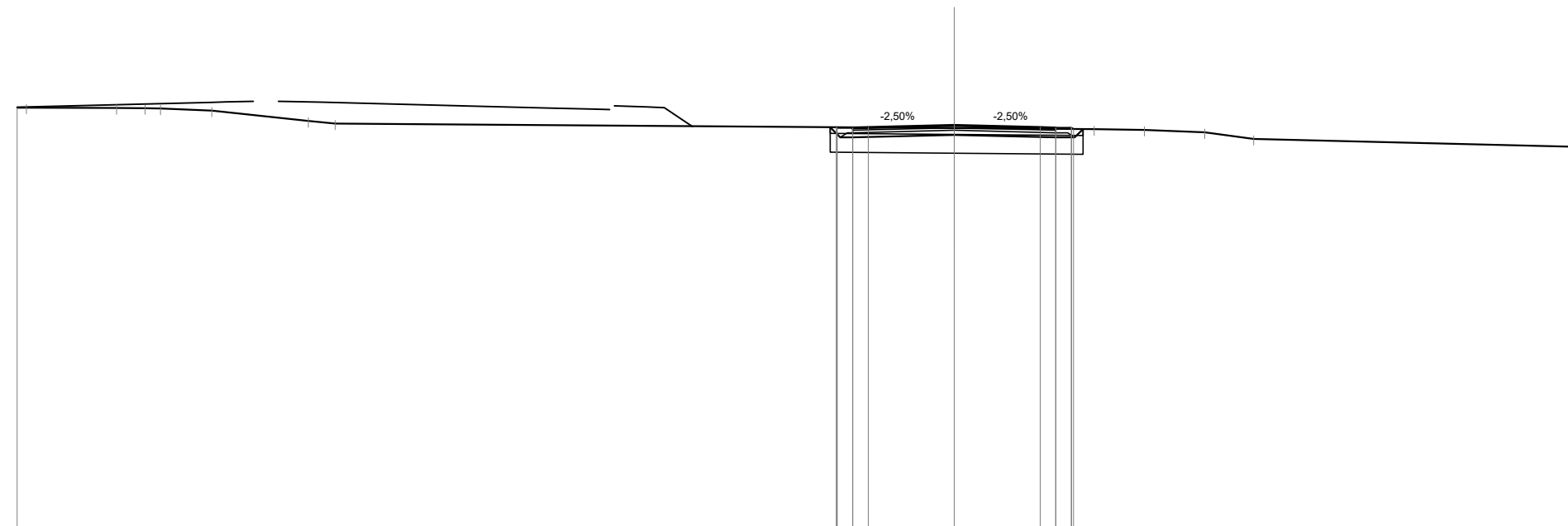

Quote Progetto Pavim.						325.83	325.81	325.83	325.90	325.83	325.81	325.77						
Dist. Parz. Progetto Pavim.						0.50	0.50	2.75	2.75	0.50	0.50							
Dist. Progetto Pavim.						3.77	3.75	-3.25	-2.75									
Quote Progetto Sottof.						325.83	325.50	325.50	325.59	325.50	325.50	325.77						
Dist. Parz. Progetto Sottof.						0.33	0.40	3.25	3.25	0.60								
Dist. Progetto Sottof.						3.97	3.65	3.25	0.00	3.25	3.85	4.12						
Quote Terreno	326.45	326.46	326.45	326.44	326.43	326.36	326.03	325.95	325.80	325.74	325.67	325.46	325.20					
Distanze Terreno	-30.00	-29.70	-26.82	-25.89	-25.41	-23.77	-20.68	-19.81	0.00	4.48	6.09	8.02	9.59	20.00				

SCAVI E BONIFICHE	
SCOTICO	7.72 m
BONIFICA	4.63 mq

RILEVATI	
RILEVATO	1.80 mq
TERRENO VEGETALE	2.13 m

SOVRASTRUTTURA STRADALE	
STRATO DI USURA	6.50 m
STRATO DI BINDER	6.50 m
STRATO DI BASE	6.50 m
STRATO DI FONDAZIONE	1.14 mq

SEZIONE N. : 71

Qt. prog. : 320.43

Progr. Km : 1+400.000

Scala 1:200

Qt. rif. 307.000

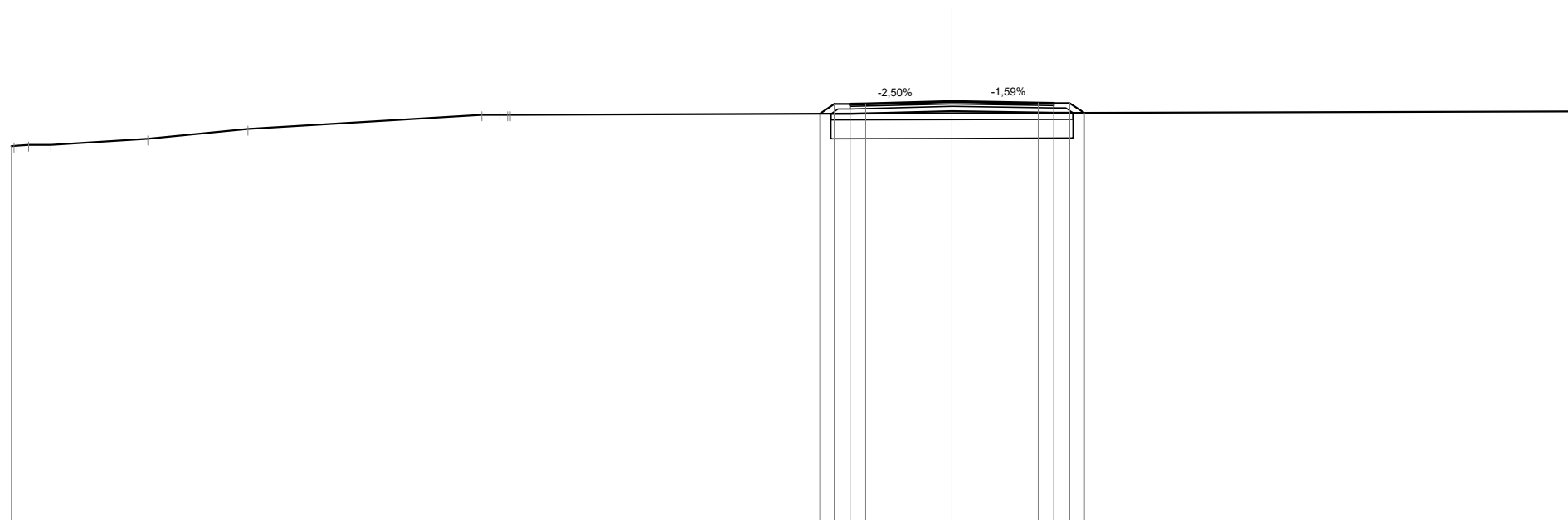

Quote Progetto Pavim.									320.03	320.34	320.31	320.36	320.43	320.38	320.37	320.06
Dist. Parz. Progetto Pavim.									0.47	0.50	0.50		2.75	2.75	0.50	0.47
Dist. Progetto Pavim.									-4.22	-3.75	-3.25	-2.75	0.00	2.75	3.25	4.22
Quote Progetto Sottof.									320.03	320.03	320.03	320.06	320.12	320.06	320.06	320.06
Dist. Parz. Progetto Sottof.									0.00	0.60	3.25	3.25	3.25	0.60	3.25	4.22
Dist. Progetto Sottof.									-3.86	-3.25	0.00	3.25	0.00	-3.25	3.85	3.86
Quote Terreno	319.00	319.04	319.04	319.23	319.55	320.00	320.00	320.00					320.05			320.11
Distanze Terreno	-30.00	-29.45	-28.74	-25.65	-22.45	-14.99	-14.44	-14.09					0.00			20.00

SCAVI E BONIFICHE	
SCOTICO	7.97 m
BONIFICA	4.79 mq

RILEVATI	
RILEVATO	1.93 mq
TERRENO VEGETALE	2.26 m

SOVRASTRUTTURA STRADALE	
STRATO DI USURA	6.50 m
STRATO DI BINDER	6.50 m
STRATO DI BASE	6.50 m
STRATO DI FONDAZIONE	1.14 mq

SEZIONE N. : 72
 Qt. prog. : 320.41
 Progr. Km : 1+420.000

Scala 1:200

Qt. rif. 307.000

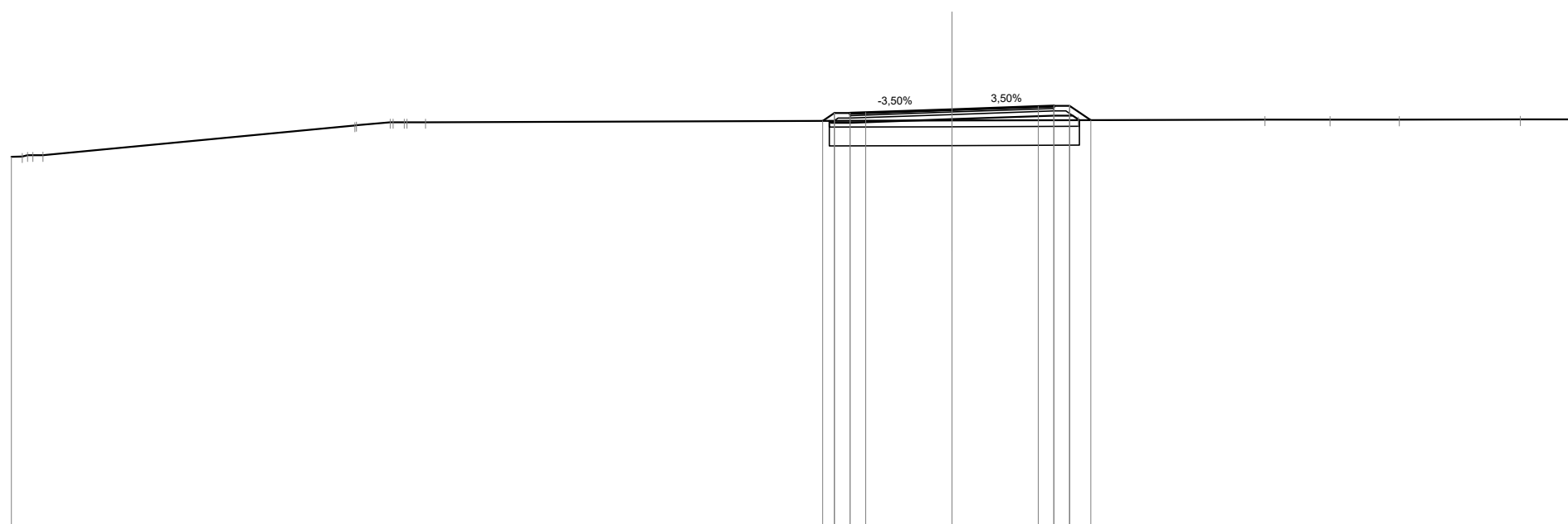

Quote Progetto Pavim.						320.04	320.20	320.26	320.31	320.41	320.50	320.52	320.07				
Dist. Parz. Progetto Pavim.						0.38	0.50	0.50	2.75	2.75	0.50	0.50	0.68				
Dist. Progetto Pavim.						-4.13	-3.75	-3.25	-2.75	0.00	-2.75	-3.25	-3.75	-4.43			
Quote Progetto Sottof.						320.04	319.98			320.10	320.21	320.21	320.07				
Dist. Parz. Progetto Sottof.						0.06	0.60	3.25		3.25	0.60						
Dist. Progetto Sottof.						-3.91	-3.25			0.00	-3.25	-3.85	-4.07				
Quote Terreno	318.89	318.91	318.95			319.89	319.91	320.00	320.00	320.05	320.07	320.09	320.08	320.08	320.09	320.09	
Distanze Terreno	-30.00	-29.65	-28.99			-19.04	-18.99	-17.92	-17.46	-16.79	0.00	4.03	9.98	12.06	14.27	18.13	20.00

SCAVI E BONIFICHE	
SCOTICO	8.03 m
BONIFICA	4.82 mq

RILEVATI	
RILEVATO	1.76 mq
TERRENO VEGETALE	2.15 m

SOVRASTRUTTURA STRADALE	
STRATO DI USURA	6.50 m
STRATO DI BINDER	6.50 m
STRATO DI BASE	6.50 m
STRATO DI FONDAZIONE	1.14 mq

SEZIONE N. : 74
 Qt. prog. : 321.13
 Progr. Km : 1+460.000

Scala 1:200

Qt. rif. 307.000

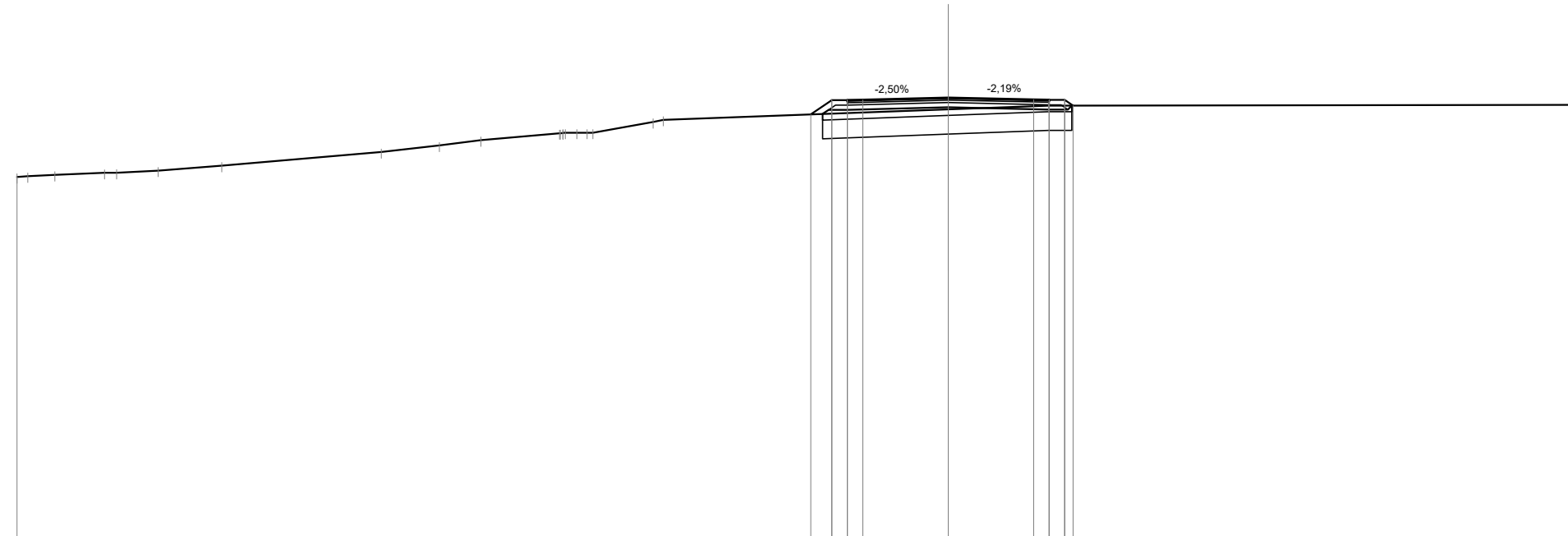

Quote Progetto Pavim.										320.59	321.05	321.02	321.06	321.13	321.07	321.06	320.87	
Dist. Parz. Progetto Pavim.										0.68	0.50	0.50	0.50	2.75	2.75	0.50	0.50	
Dist. Progetto Pavim.										-4.43	-3.75	-3.25	-2.75	0.00	0.00	-2.75	-3.25	-4.02
Quote Progetto Sottof.										320.60	320.74	320.74	320.74	320.82	320.75	320.75	320.87	
Dist. Parz. Progetto Sottof.										0.20	0.60	0.60	3.25	3.25	0.60	0.60	3.98	
Dist. Progetto Sottof.										-4.05	-3.25	-3.25	0.00	0.00	-3.25	-3.85	3.98	
Quote Terreno	318.58	318.60	318.64	318.71	318.71	318.78	318.94	319.38	319.59	319.76	319.98	320.00	320.00	320.34	320.42	320.87	320.87	320.90
Distanze Terreno	-30.00	-29.65	-28.77	-27.18	-26.78	-25.45	-23.40	-18.26	-16.39	-15.05	-12.52	-11.96	-11.44	-9.51	-9.18	0.00	3.22	20.00

SCAVI E BONIFICHE	
SCOTICO	7.97 m
BONIFICA	4.78 mq

RILEVATI	
RILEVATO	2.02 mq
TERRENO VEGETALE	2.44 m

SOVRASTRUTTURA STRADALE	
STRATO DI USURA	6.50 m
STRATO DI BINDER	6.50 m
STRATO DI BASE	6.50 m
STRATO DI FONDAZIONE	1.14 mq

SEZIONE N. : 75
 Qt. prog. : 321.28
 Progr. Km : 1+480.000

Scala 1:200

Qt. rif. 307.000

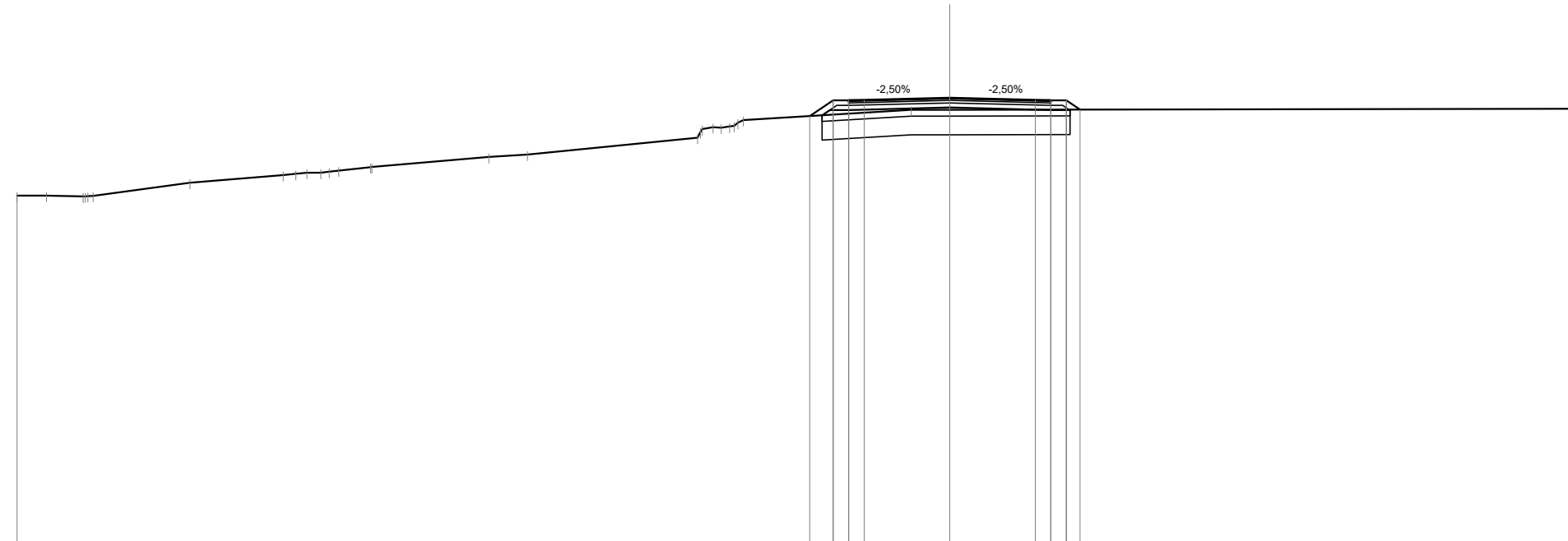

Quote Progetto Pavim.							320.69	321.20	321.17	321.21		321.28		321.21	321.20	321.20	320.90
Dist. Parz. Progetto Pavim.							0.75	0.50	0.50		2.75		2.75		0.50	0.50	0.44
Dist. Progetto Pavim.							-4.50	-3.75	-3.25	-2.75		0.00		-2.75	-3.25	-3.75	-4.19
Quote Progetto Sottof.							320.72	320.86	320.89			320.97		320.89	320.89	320.90	
Dist. Parz. Progetto Sottof.							0.25	0.60		3.25		3.25		0.60			
Dist. Progetto Sottof.							-4.11	-3.85	-3.25		0.00		-3.25	-3.85	-3.87		
Quote Terreno	318.14	318.13	318.11	318.13	318.55	318.80	318.88	318.88	318.94	319.05	319.06	319.38	319.46	320.00	320.34	320.36	320.57
Distanze Terreno	-30.00	-29.05	-27.87	-27.55	-24.43	-21.44	-20.68	-20.23	-19.65	-18.63	-18.58	-14.83	-13.58	-8.11	-7.61	-7.08	-6.64

SCAVI E BONIFICHE	
SCOTICO	8.29 m
BONIFICA	4.98 mq

RILEVATI	
RILEVATO	1.99 mq
TERRENO VEGETALE	2.13 m

SOVRASTRUTTURA STRADALE	
STRATO DI USURA	6.50 m
STRATO DI BINDER	6.50 m
STRATO DI BASE	6.50 m
STRATO DI FONDAZIONE	1.14 mq

SEZIONE N. : 76
 Qt. prog. : 320.67
 Progr. Km : 1+500.000

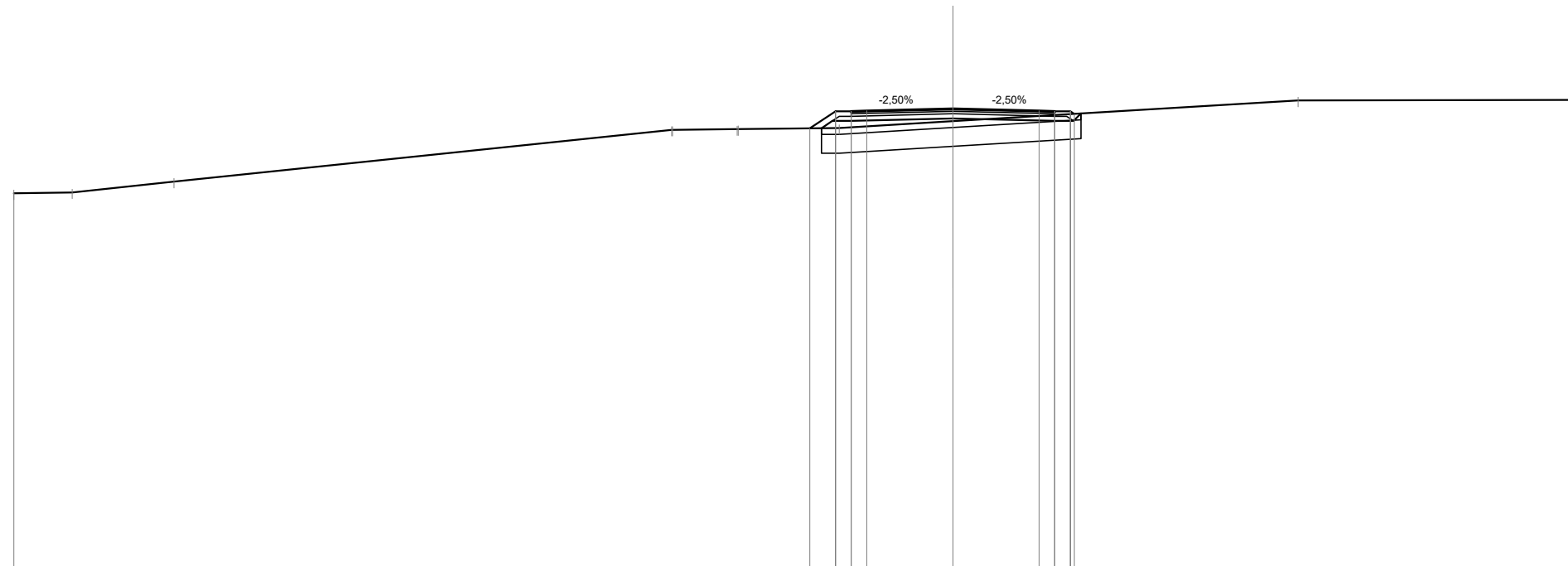

Scala 1:200

Qt. rif. 306.000

Quote Progetto Pavim.						320.05	320.59	320.56	320.60		320.67		320.60	320.59	320.51
Dist. Parz. Progetto Pavim.						0.82	0.50	0.50	2.75		2.75		0.50	0.50	
Dist. Progetto Pavim.						-4.57	-3.75	-3.25			-0.00		-2.75	-3.25	-3.88
Quote Progetto Sottof.						320.05	320.28	320.28		320.36			320.28	320.28	320.52
Dist. Parz. Progetto Sottof.						0.35	0.60		3.25		3.25		0.60		
Dist. Progetto Sottof.						-4.20	-3.85	-3.25		-0.00			-3.25	-3.85	-4.09
Quote Terreno	317.97	318.00	318.35		320.00	320.00	320.02	320.02	320.06		320.27			320.94	320.95
Distanze Terreno	-30.00	-28.14	-24.88		-8.99	-8.96	-6.89	-6.85	-3.63		-0.00			-11.03	-20.00

SCAVI E BONIFICHE	
SCOTICO	7.80 m
BONIFICA	4.68 mq
RILEVATI	
RILEVATO	1.88 mq
TERRENO VEGETALE	2.13 m
SOVRASTRUTTURA STRADALE	
STRATO DI USURA	6.50 m
STRATO DI BINDER	6.50 m
STRATO DI BASE	6.50 m
STRATO DI FONDAZIONE	1.14 mq

SEZIONE N. : 77
 Qt. prog. : 320.50
 Progr. Km : 1+520.000

Scala 1:200

Qt. rif. 306.000

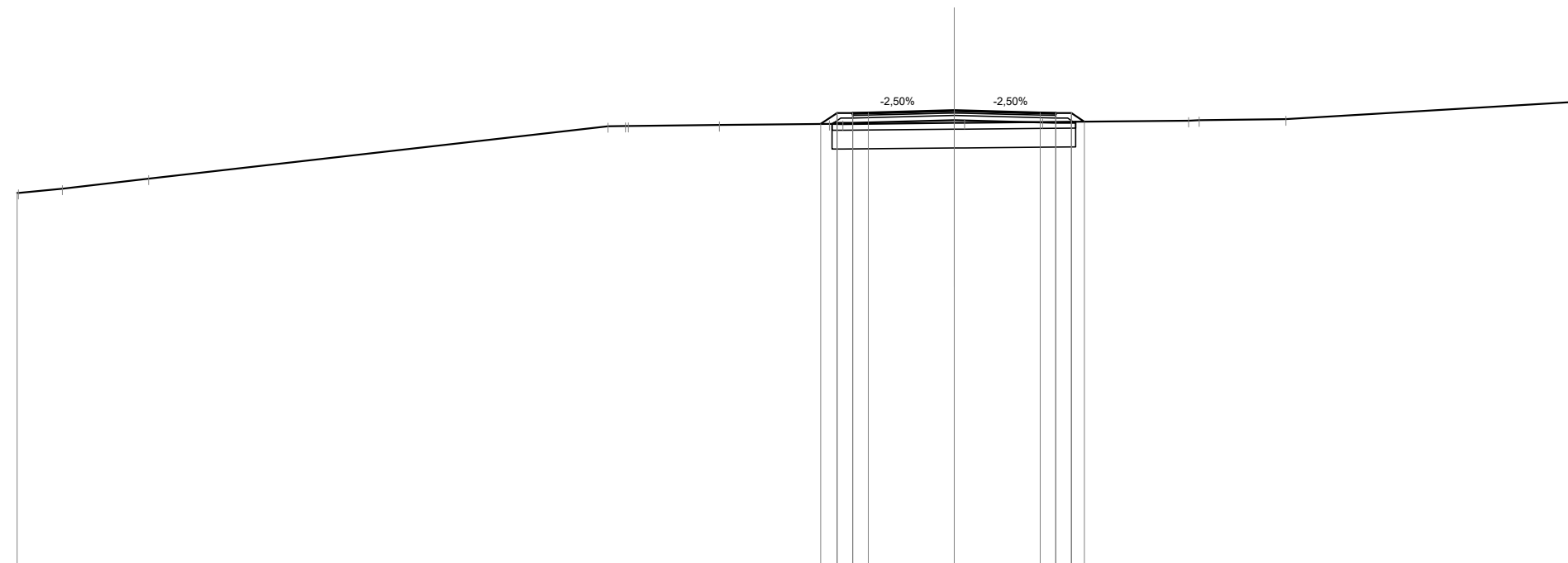

Quote Progetto Pavim.							320.07	320.42	320.39	320.43		320.50		320.43	320.42	320.42	320.14	
Dist. Parz. Progetto Pavim.							0.52	0.50	0.50		2.75		2.75	0.50	0.50	0.42		
Dist. Progetto Pavim.							-4.27	-3.75	-3.25	-2.75		0.00		-2.75	-3.25	-3.75	-4.17	
Quote Progetto Sottof.							320.07	320.11	320.11			320.19		320.11	320.11	320.14		
Dist. Parz. Progetto Sottof.							0.06	0.60		3.25		3.25		0.60				
Dist. Progetto Sottof.							-3.91	-3.25			0.00			-3.25	-3.85	-3.88		
Quote Terreno	317.86	317.87					320.07	320.07	320.04		320.10	320.11		320.13				
Distanze Terreno	-30.00	-29.96	-28.55	-25.79	-318.32		-4.00	-3.56	-7.52		0.00	0.33		-2.83				

SCAVI E BONIFICHE	
SCOTICO	7.83 m
BONIFICA	4.70 mq

RILEVATI	
RILEVATO	1.88 mq
TERRENO VEGETALE	2.20 m

SOVRASTRUTTURA STRADALE	
STRATO DI USURA	6.50 m
STRATO DI BINDER	6.50 m
STRATO DI BASE	6.50 m
STRATO DI FONDAZIONE	1.14 mq

SEZIONE N. : 78

Qt. prog. : 320.56

Progr. Km : 1+540.000

Scala 1:200

Qt. rif. 306.000

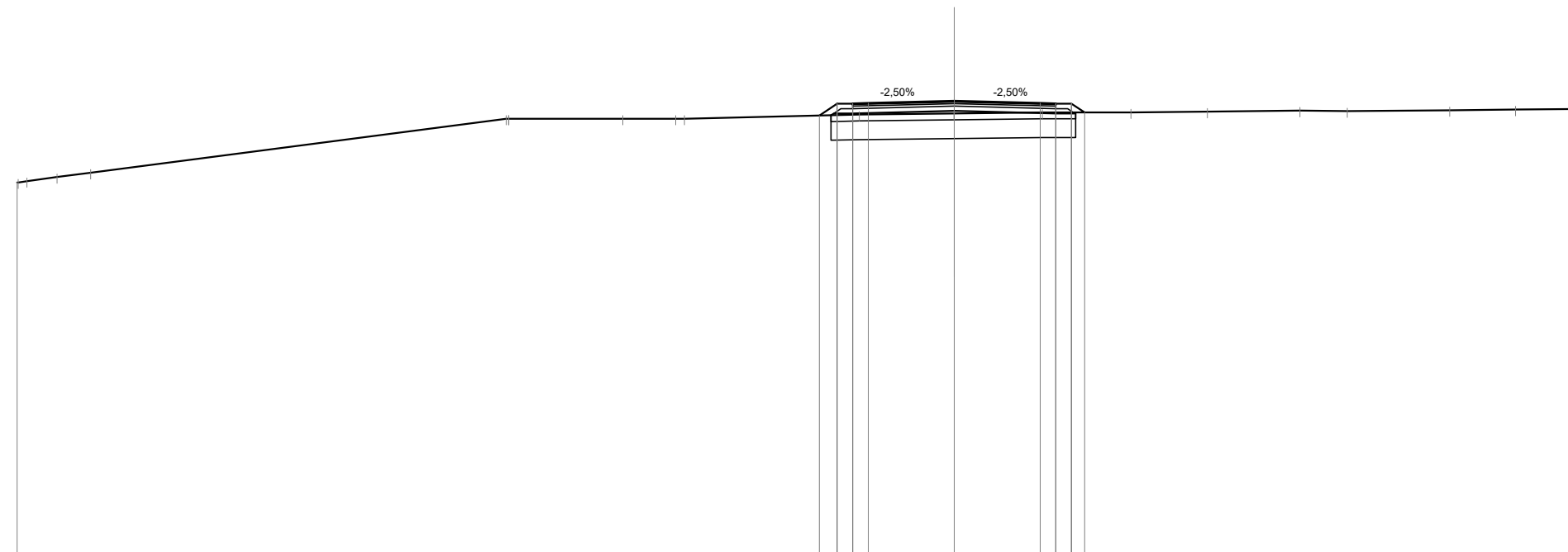

Quote Progetto Pavim.							320.10	320.48	320.45	320.49		320.56		320.49	320.48	320.48	320.20						
Dist. Parz. Progetto Pavim.							0.57	0.50	0.50		2.75		2.75	0.50	0.50	0.42							
Dist. Progetto Pavim.							-4.32	-3.75	-3.25				-0.00	-2.75	-3.25	-3.75	-4.17						
Quote Progetto Sottof.							320.11	320.17				320.25		320.17	320.17	320.20							
Dist. Parz. Progetto Sottof.							0.09	0.60		3.25		3.25		0.60									
Dist. Progetto Sottof.							-3.95	-3.25				-0.00		-3.25	-3.85	-3.88							
Quote Terreno	317.96	318.00			320.00	320.00			320.13		320.16	320.16		320.20		320.20	320.23	320.26	320.24	320.27	320.29	320.31	
Distanze Terreno	-30.00	-29.68	-28.72	-27.64	-14.34	-14.26			-10.61	-8.91	-8.64		-3.04	-0.01	0.00	2.82	5.66	8.10	11.06	12.58	15.86	17.97	20.00

SCAVI E BONIFICHE	
SCOTICO	7.98 m
BONIFICA	4.79 mq

RILEVATI	
RILEVATO	2.62 mq
TERRENO VEGETALE	2.42 m

SOVRASTRUTTURA STRADALE	
STRATO DI USURA	6.50 m
STRATO DI BINDER	6.50 m
STRATO DI BASE	6.50 m
STRATO DI FONDAZIONE	1.14 mq

SEZIONE N. : 79
 Qt. prog. : 320.56
 Progr. Km : 1+560.000

Scala 1:200

Qt. rif. 306.000

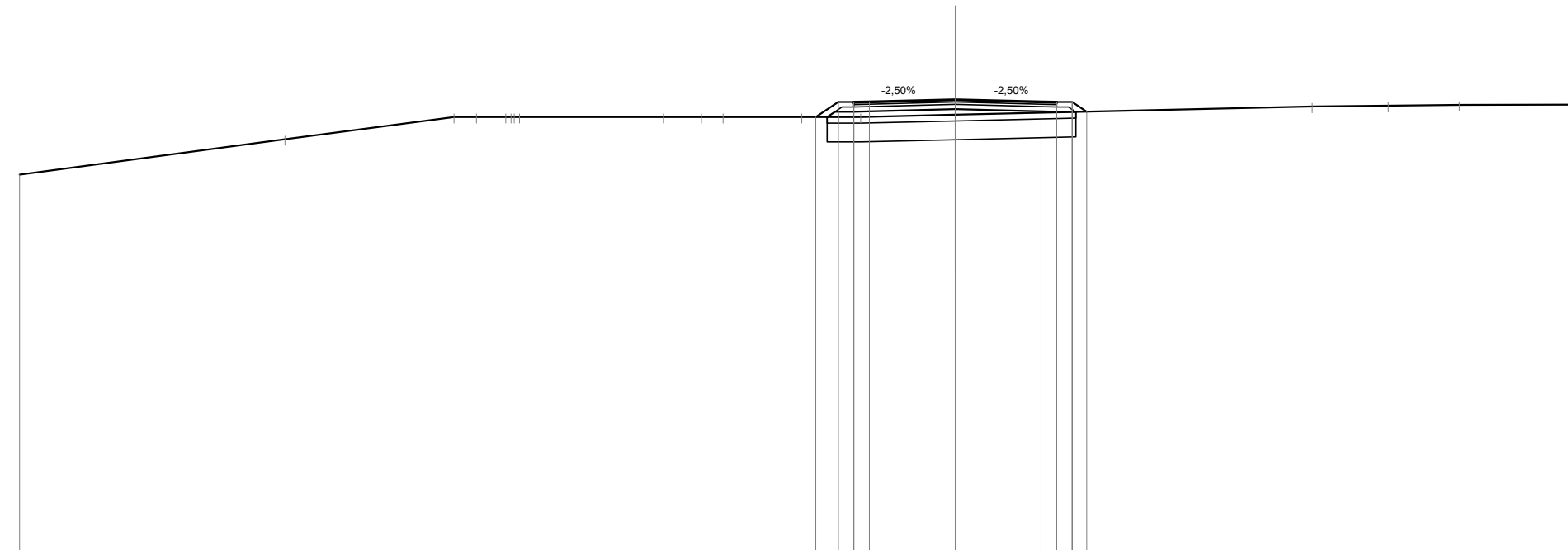

Quote Progetto Pavim.						320.00	320.48	320.45	320.49		320.56		320.49	320.48	320.17
Dist. Parz. Progetto Pavim.						0.72	0.50	0.50	2.75	2.75			0.50	0.50	0.47
Dist. Progetto Pavim.						-4.47	-3.75	-3.25			0.00		-2.75	-3.25	-4.22
Quote Progetto Sottof.						320.00	320.17	320.17			320.25		320.17	320.17	320.16
Dist. Parz. Progetto Sottof.						0.25	0.60	3.25			3.25		0.60		
Dist. Progetto Sottof.						-4.11	-3.85	-3.25			0.00		-3.25	-3.85	-3.87
Quote Terreno	318.15					320.00	320.00	320.00			320.07		320.33	320.36	320.39
Distanze Terreno	-30.00					-4.92	-3.75	-3.04			0.00		-11.45	-13.89	-16.16

SCAVI E BONIFICHE	
SCOTICO	8.10 m
BONIFICA	4.85 mq

RILEVATI	
RILEVATO	2.45 mq
TERRENO VEGETALE	2.38 m

SOVRASTRUTTURA STRADALE	
STRATO DI USURA	6.50 m
STRATO DI BINDER	6.50 m
STRATO DI BASE	6.50 m
STRATO DI FONDAZIONE	1.14 mq

SEZIONE N. : 81
 Qt. prog. : 320.32
 Progr. Km : 1+600.000

Scala 1:200

Qt. rif. 306.000

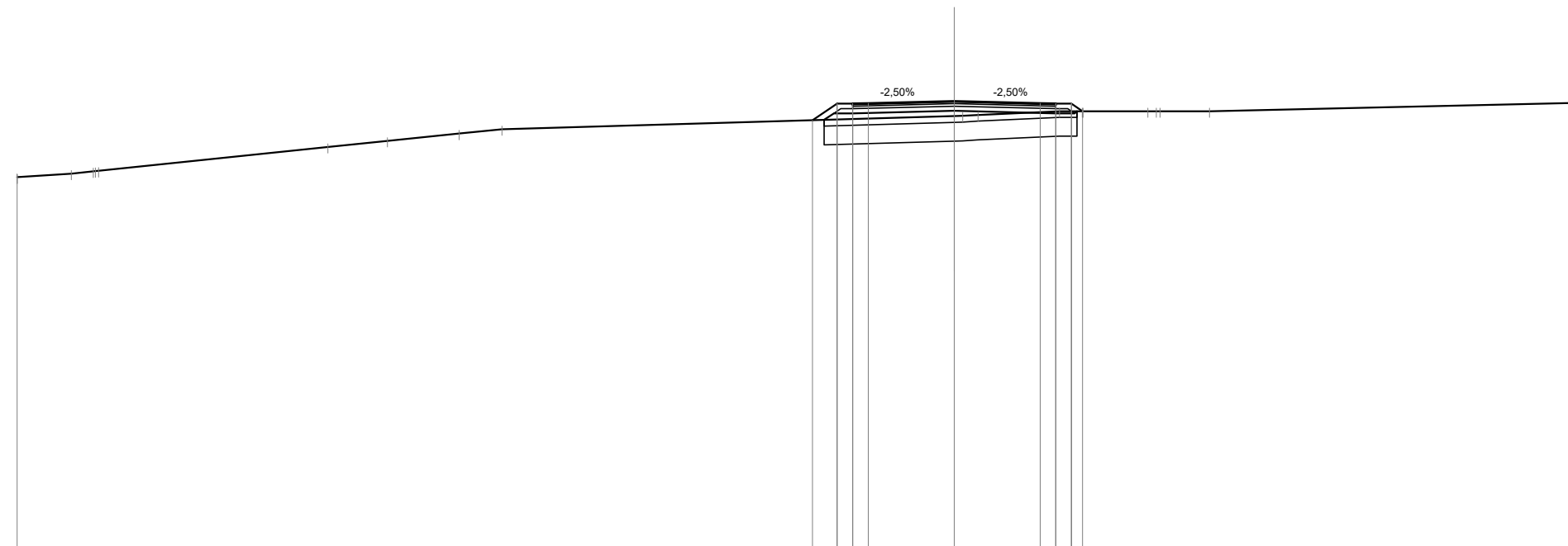

Quote Progetto Pavim.						319.71		320.24		320.21		320.25		320.32		320.25		320.24		320.24		320.00
Dist. Parz. Progetto Pavim.						0.79		0.50		0.50		2.75		2.75		0.50		0.50		0.38		
Dist. Progetto Pavim.						-4.54		-3.75		-3.25		-2.75		0.00		-2.75		-3.25		-3.75		-4.11
Quote Progetto Sottof.						319.72		319.93		319.93				320.01		319.93		319.93		320.00		320.00
Dist. Parz. Progetto Sottof.						0.31		0.60				3.25		3.25		0.60						
Dist. Progetto Sottof.						-4.16		-3.85		-3.25				0.00		-3.25		-3.85		-3.92		
Quote Terreno	317.89	317.89	318.00	318.09	318.86	319.05	319.29	319.42			319.84	319.88	320.00	320.00	320.00	320.00	320.00					320.27
Distanze Terreno	-30.00	-28.26	-27.56	-27.39	-20.05	-18.15	-15.85	-14.48			0.00	0.76	3.37	4.10	4.12	6.20	6.69	8.17				20.00

SCAVI E BONIFICHE	
SCOTICO	7.98 m
BONIFICA	4.78 mq

RILEVATI	
RILEVATO	1.89 mq
TERRENO VEGETALE	2.47 m

SOVRASTRUTTURA STRADALE	
STRATO DI USURA	6.50 m
STRATO DI BINDER	6.50 m
STRATO DI BASE	6.50 m
STRATO DI FONDAZIONE	1.14 mq

SEZIONE N. : 82
 Qt. prog. : 320.15
 Progr. Km : 1+620.000

Scala 1:200

Qt. rif. 306.000

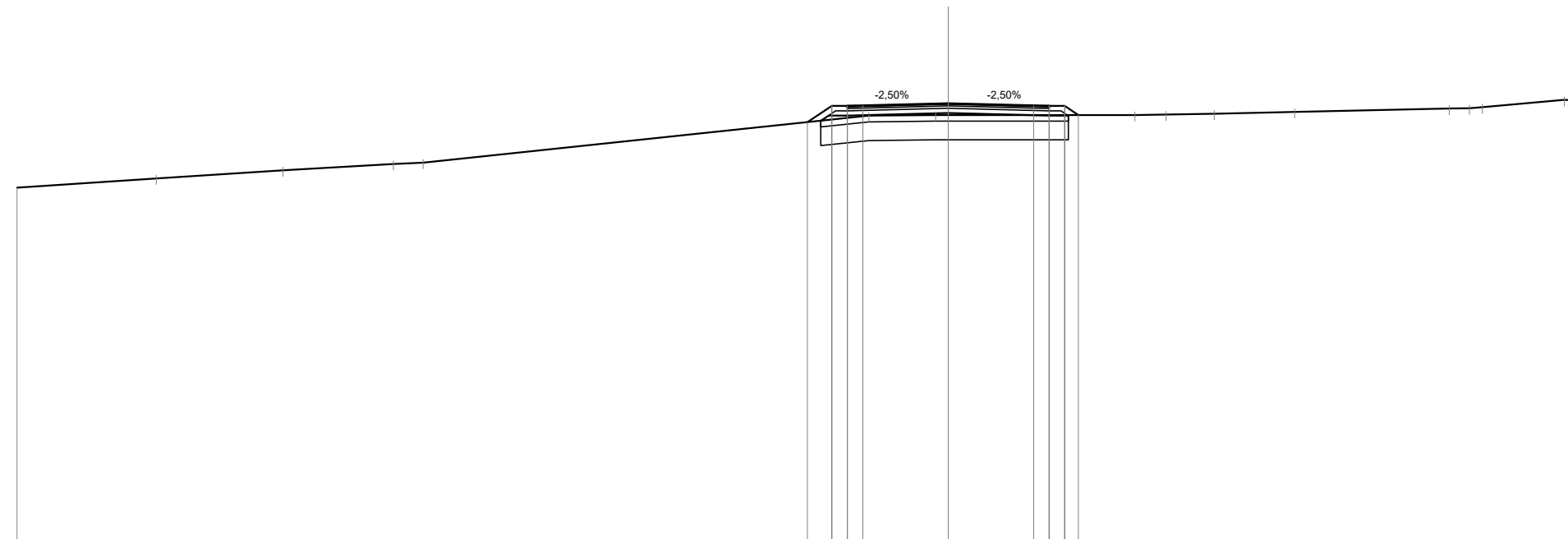

Quote Progetto Pavim.						319.55	320.07	320.04	320.08	320.15	320.08	320.07	319.78									
Dist. Parz. Progetto Pavim.						0.79	0.50	0.50	0.50	2.75	2.75	0.50	0.50	0.44								
Dist. Progetto Pavim.						-4.54	-3.75	-3.25	-2.75	0.00	0.00	-2.75	-3.25	-3.75	-4.19							
Quote Progetto Sottof.						319.59	319.76	319.76	319.76	319.84	319.84	319.76	319.76	319.78								
Dist. Parz. Progetto Sottof.						0.25	0.60	0.60	3.25	3.25	3.25	0.60	0.60	0.44								
Dist. Progetto Sottof.						-4.11	-3.85	-3.25	0.00	0.00	0.00	-3.25	-3.85	-3.87								
Quote Terreno	317.44	317.74	318.00	318.20	318.25	319.76	319.78	319.78	319.78	319.78	319.78	319.78	319.78	319.80	319.82	319.88	319.98	320.26				
Distanze Terreno	-30.00	-25.51	-21.43	-17.87	-16.92	-2.56	-0.41	0.00	0.00	0.00	0.00	0.00	0.00	6.01	7.01	8.57	11.16	16.14	16.79	17.20	19.85	20.00

SCAVI E BONIFICHE	
SCOTICO	8.21 m
BONIFICA	4.91 mq

RILEVATI	
RILEVATO	2.02 mq
TERRENO VEGETALE	1.95 m

SOVRASTRUTTURA STRADALE	
STRATO DI USURA	6.50 m
STRATO DI BINDER	6.50 m
STRATO DI BASE	6.50 m
STRATO DI FONDAZIONE	1.11 mq

SEZIONE N. : 84
 Qt. prog. : 318.69
 Progr. Km : 1+660.000

Scala 1:200

Qt. rif. 305.000

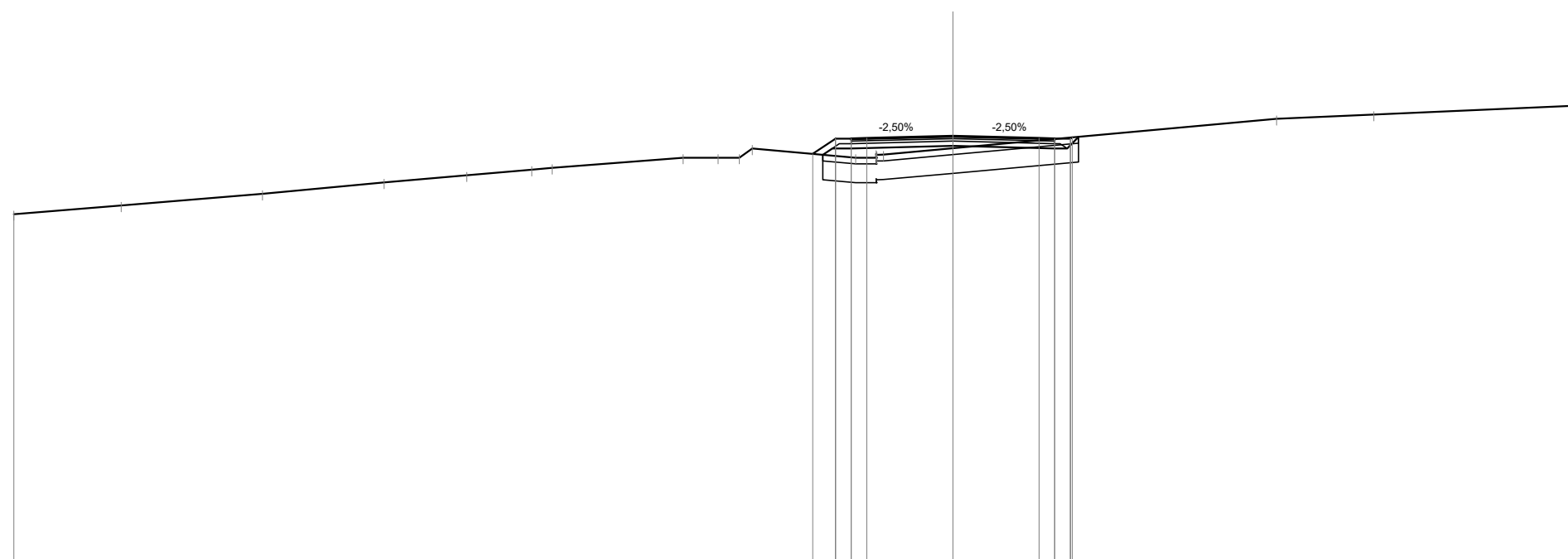

Quote Progetto Pavim.											318.12	318.61	318.58	318.62			318.69		318.62	318.61	318.65
Dist. Parz. Progetto Pavim.											0.73	0.50	0.50	2.75			2.75		0.50	0.50	3.81
Dist. Progetto Pavim.											-4.48	-3.75	-3.25	-2.75			0.00		-2.75	-3.25	-3.81
Quote Progetto Sottof.											318.09	318.30	318.30				318.38		318.30	318.66	
Dist. Parz. Progetto Sottof.											0.31	0.60		3.25			3.25		0.40		
Dist. Progetto Sottof.											-4.16	-3.85	-3.25				0.00		-3.25	-4.01	
Quote Terreno	316.20	316.47	316.84	317.21	317.44	317.62	317.68	318.00	318.00	318.00	318.13	318.10	318.30	318.30	319.24	319.37	319.66				
Distanze Terreno	-30.00	-26.57	-22.05	-18.17	-15.53	-13.45	-12.80	-8.62	-7.50	-6.82	-6.41	-3.11	-2.46	-2.22	0.00	10.33	13.44	20.00			

SCAVI E BONIFICHE	
SCOTICO	8.36 m
BONIFICA	5.02 mq

RILEVATI	
RILEVATO	2.61 mq
TERRENO VEGETALE	2.48 m

SOVRASTRUTTURA STRADALE	
STRATO DI USURA	6.50 m
STRATO DI BINDER	6.50 m
STRATO DI BASE	6.50 m
STRATO DI FONDAZIONE	1.14 mq

SEZIONE N. : 85
 Qt. prog. : 318.75
 Progr. Km : 1+680.000

Scala 1:200

Qt. rif. 305.000

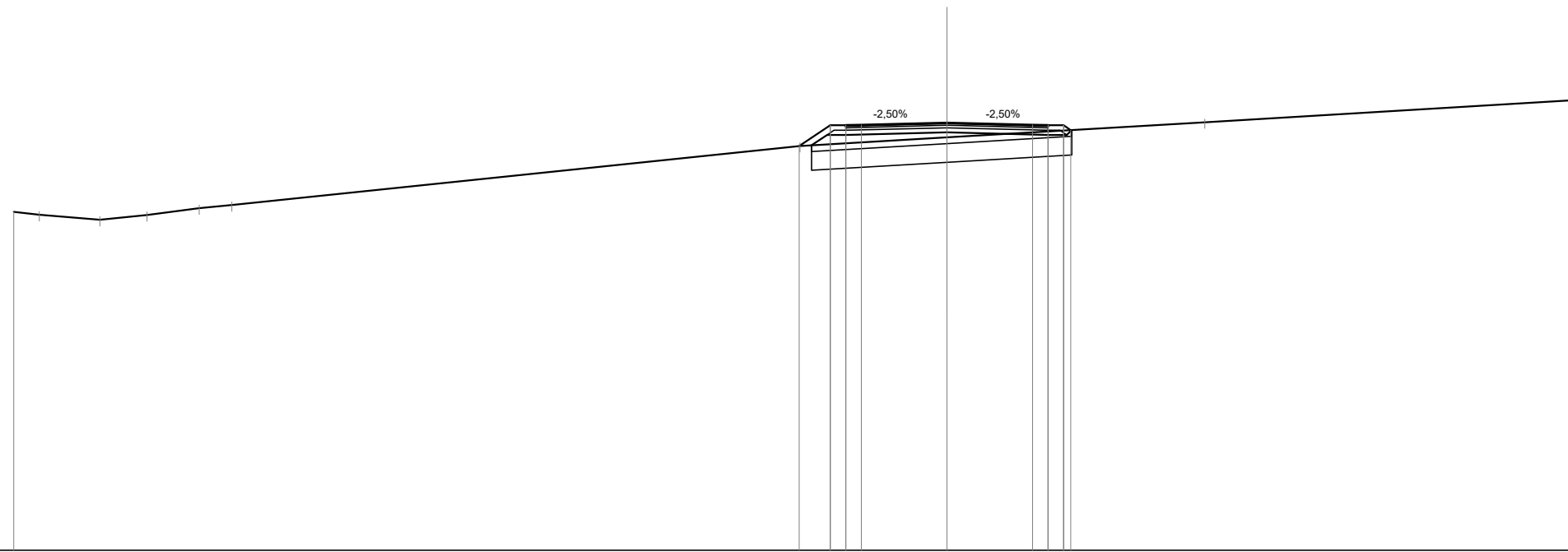

Quote Progetto Pavim.									318.00			318.68								
Dist. Parz. Progetto Pavim.									1.00		0.50		0.50							
Dist. Progetto Pavim.									-4.75		-3.75		-3.25							
Quote Progetto Sottof.									318.02		318.35		318.35							
Dist. Parz. Progetto Sottof.									0.50		0.60		3.25							
Dist. Progetto Sottof.									-4.35		-3.85		-3.25							
Quote Terreno	315.88	315.79	315.63	315.78	316.00	316.10			318.00		318.28		318.76							
Distanze Terreno	-30.00	-29.18	-27.23	-25.71	-24.04	-22.99			-4.72		0.00		-8.29							

SCAVI E BONIFICHE	
SCOTICO	8.26 m
BONIFICA	4.95 mq

RILEVATI	
RILEVATO	1.82 mq
TERRENO VEGETALE	2.13 m

SOVRASTRUTTURA STRADALE	
STRATO DI USURA	6.50 m
STRATO DI BINDER	6.50 m
STRATO DI BASE	6.50 m
STRATO DI FONDAZIONE	1.14 mq

SEZIONE N. : 87
 Qt. prog. : 318.87
 Progr. Km : 1+720.000

Scala 1:200

Qt. rif. 304.000

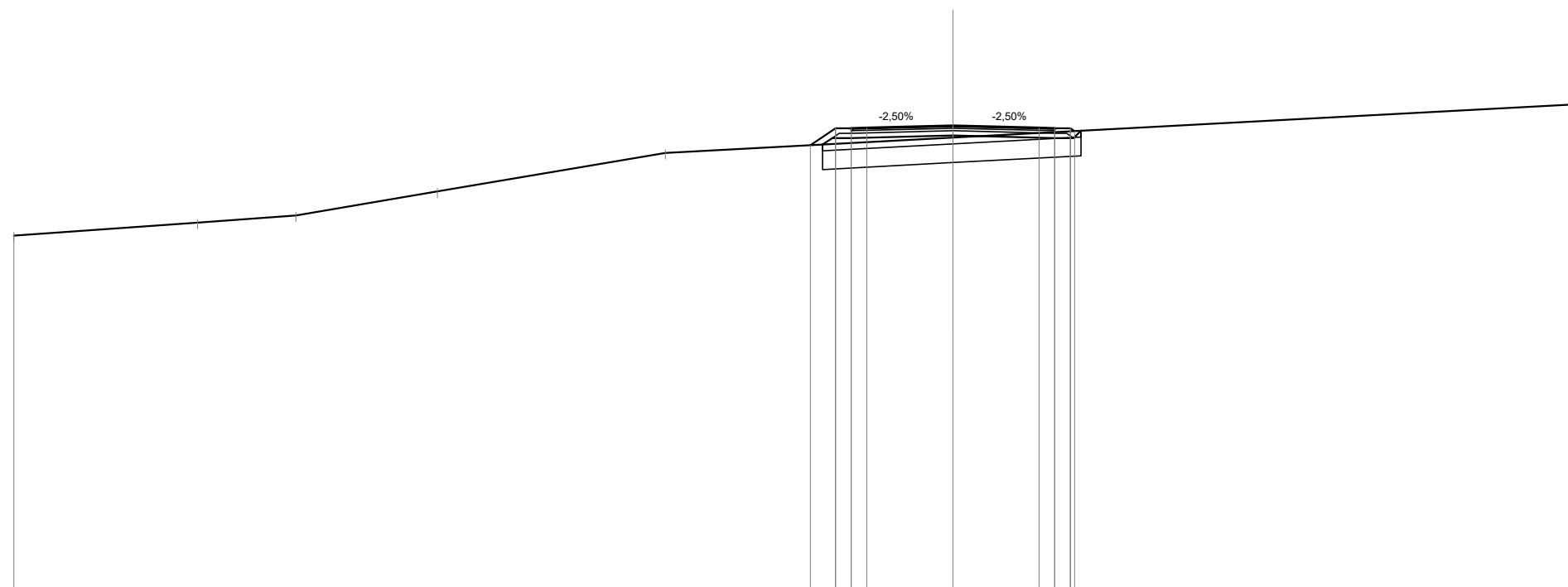

Quote Progetto Pavim.							318.25	318.78	318.75	318.80	318.87	318.80	318.78	318.70
Dist. Parz. Progetto Pavim.							0.81	0.50	0.50	2.75	2.75	0.50	0.50	
Dist. Progetto Pavim.							4.56	3.75	3.25		0.00	2.75	3.25	3.88
Quote Progetto Sottof.							318.27	318.47	318.47		318.56	318.47	318.47	318.71
Dist. Parz. Progetto Sottof.							0.31	0.60		3.25	3.25	0.60		
Dist. Progetto Sottof.							4.17	3.85	3.25		0.00	3.25	3.85	4.09
Quote Terreno	315.35	315.77	316.00	316.77	318.00						318.49			319.55
Distanze Terreno	30.00	24.13	20.99	16.47	9.18						0.00			20.00

SCAVI E BONIFICHE	
SCOTICO	8.30 m
BONIFICA	4.98 mq

RILEVATI	
RILEVATO	2.02 mq
TERRENO VEGETALE	2.23 m

SOVRASTRUTTURA STRADALE	
STRATO DI USURA	6.50 m
STRATO DI BINDER	6.50 m
STRATO DI BASE	6.50 m
STRATO DI FONDAZIONE	1.14 mq

SEZIONE N. : 86
 Qt. prog. : 318.81
 Progr. Km : 1+700.000

Scala 1:200

Qt. rif. 304.000

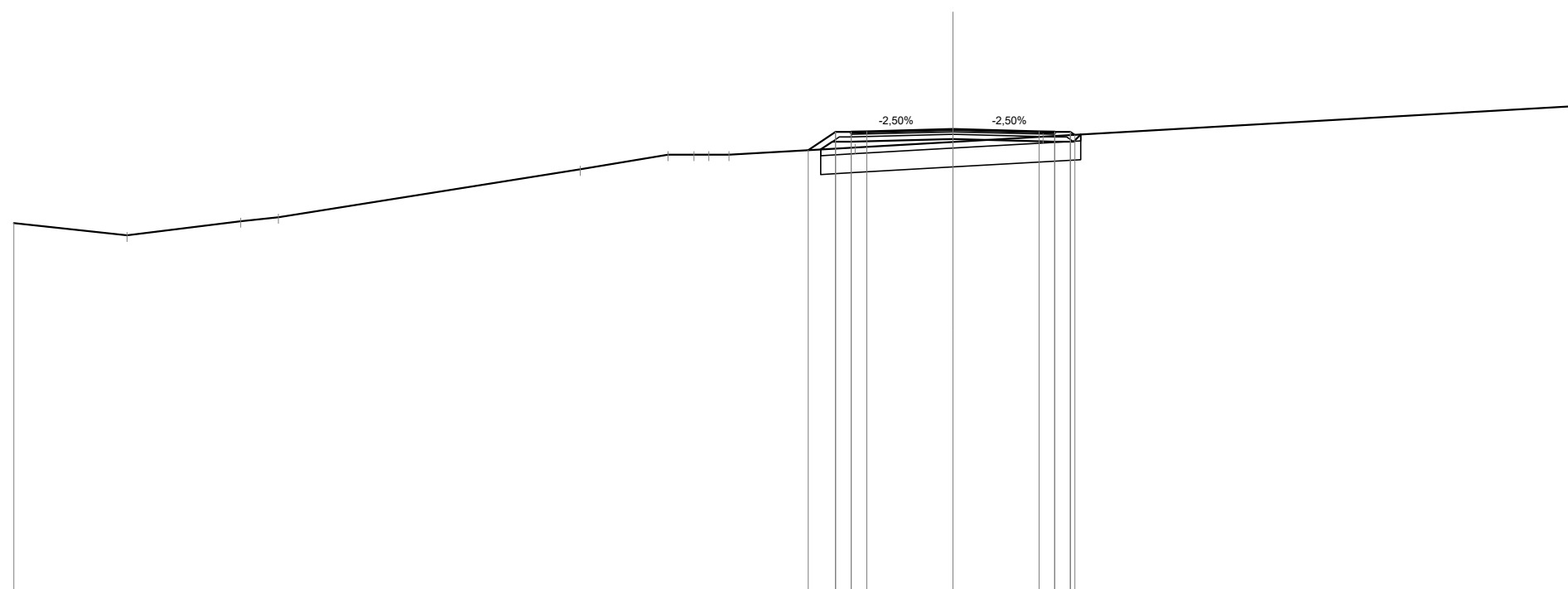

Quote Progetto Pavim.						318.14	318.72	318.69	318.74		318.81	318.74	318.72	318.63
Dist. Parz. Progetto Pavim.						0.87	0.50	0.50	2.75		2.75	0.50	0.50	
Dist. Progetto Pavim.						4.62	3.75	3.25			0.00	2.75	3.25	3.90
Quote Progetto Sottof.						318.17	318.41	318.41		318.50	318.41	318.41	318.64	
Dist. Parz. Progetto Sottof.						0.37	0.60	3.25		3.25		0.60		
Dist. Progetto Sottof.						4.23	3.85	3.25		0.00		3.25	3.85	4.08
Quote Terreno	315.81	315.42	315.87	316.00				318.23		318.41		318.57		319.55
Distanze Terreno	-30.00	-26.39	-22.75	-21.55				-3.12		0.00		-2.88		20.00

SCAVI E BONIFICHE	
SCOTICO	8.26 m
BONIFICA	4.95 mq

RILEVATI	
RILEVATO	2.13 mq
TERRENO VEGETALE	2.27 m

SOVRASTRUTTURA STRADALE	
STRATO DI USURA	6.50 m
STRATO DI BINDER	6.50 m
STRATO DI BASE	6.50 m
STRATO DI FONDAZIONE	1.14 mq

SEZIONE N. : 88
 Qt. prog. : 318.93
 Progr. Km : 1+740.000

Scala 1:200

Qt. rif. 304.000

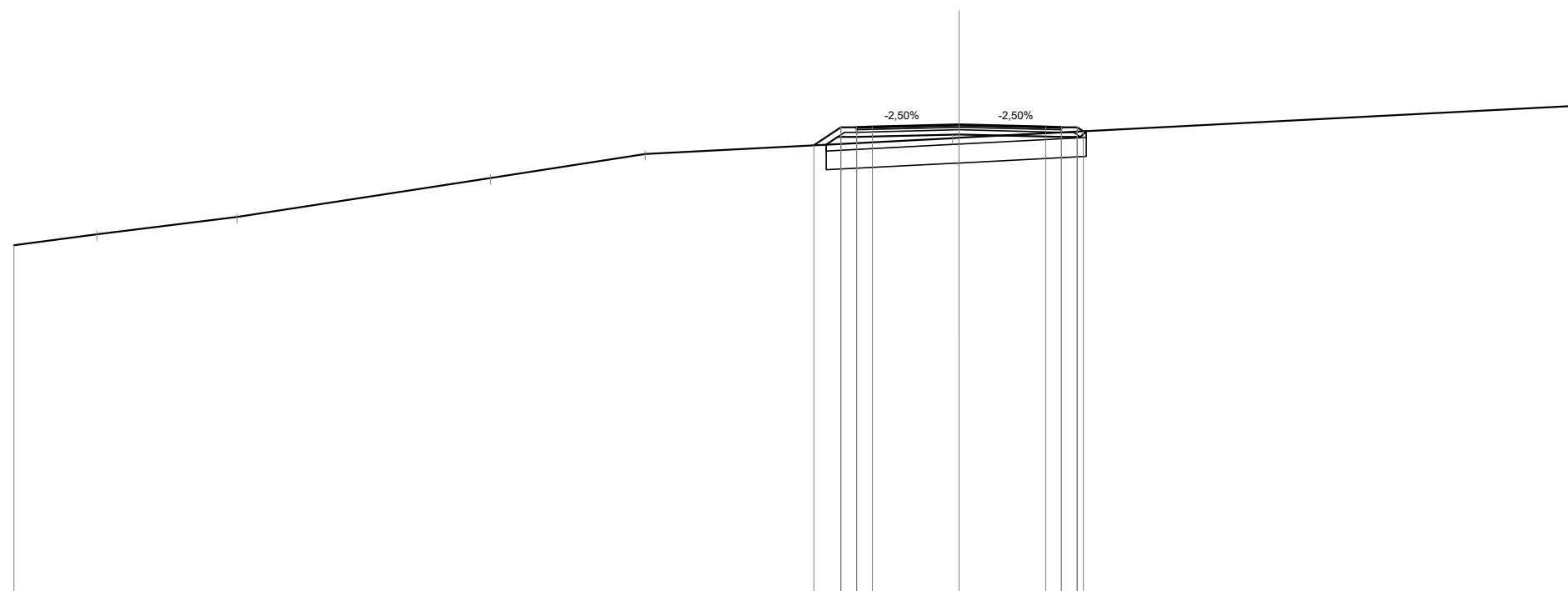

Quote Progetto Pavim.							318.27	318.84	318.81	318.86		318.93		318.86	318.84	318.84	318.71
Dist. Parz. Progetto Pavim.							0.86	0.50	0.50	2.75		2.75		0.50	0.50		
Dist. Progetto Pavim.							-4.61	-3.75	-3.25	-2.75		0.00		-2.75	-3.25	-3.75	-3.95
Quote Progetto Sottof.							318.29	318.53	318.53			318.62		318.53	318.53	318.72	
Dist. Parz. Progetto Sottof.							0.36	0.60		3.25		3.25		0.60			
Dist. Progetto Sottof.							-4.22	-3.85	-3.25			0.00		-3.25	-3.85	-4.04	
Quote Terreno	315.10	315.45	316.00	317.24	318.00							318.50	318.51				319.54
Distanze Terreno	-30.00	-27.37	-22.92	-14.87	-9.95							-0.21	0.00				20.00

SCAVI E BONIFICHE	
SCOTICO	8.23 m
BONIFICA	4.93 mq

RILEVATI	
RILEVATO	2.14 mq
TERRENO VEGETALE	2.29 m

SOVRASTRUTTURA STRADALE	
STRATO DI USURA	6.50 m
STRATO DI BINDER	6.50 m
STRATO DI BASE	6.50 m
STRATO DI FONDAZIONE	1.14 mq

SEZIONE N. : 89
 Qt. prog. : 318.83
 Progr. Km : 1+760.000

Scala 1:200

Qt. rif. 304.000

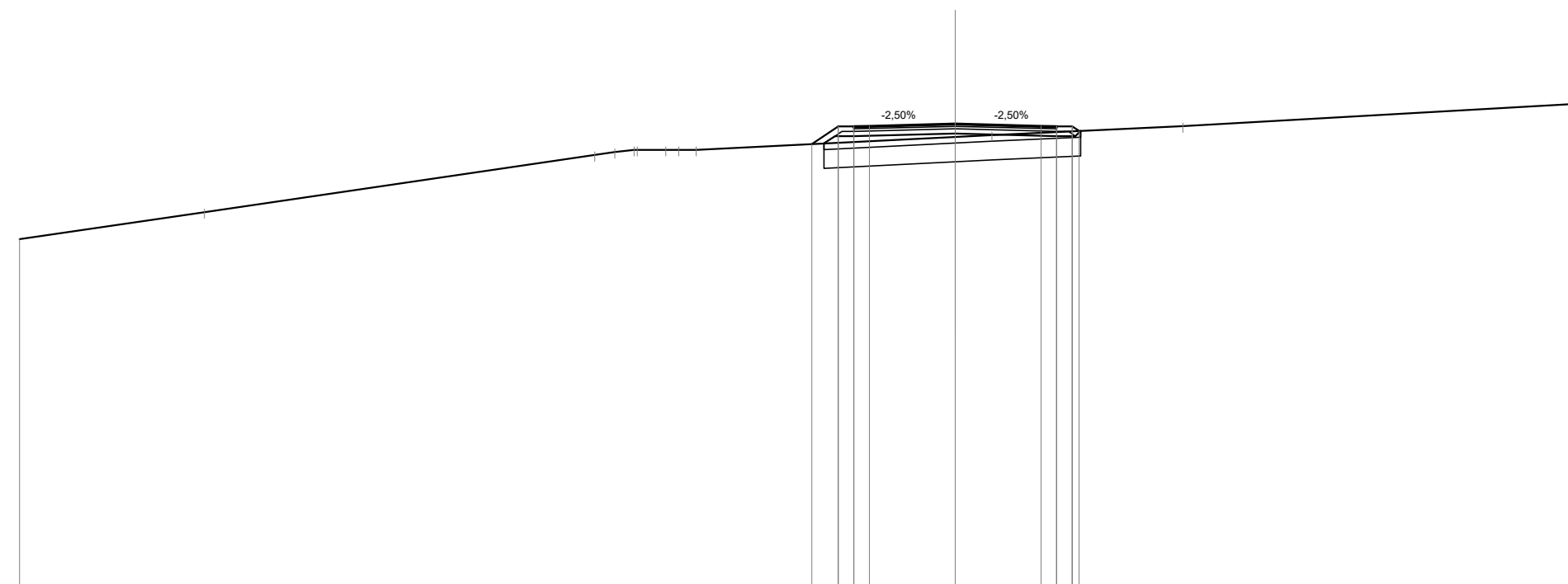

Quote Progetto Pavim.												318.18	318.75	318.72	318.76	318.83	318.76	318.75	318.60			
Dist. Parz. Progetto Pavim.												0.85	0.50	0.50	2.75	2.75	0.50	0.50				
Dist. Progetto Pavim.												-4.60	-3.75	-3.25	-2.75	-0.00	-2.75	-3.25	-3.75	-3.97		
Quote Progetto Sottof.												318.20	318.44	318.44	318.52	318.52	318.44	318.44	318.61			
Dist. Parz. Progetto Sottof.												0.35	0.60	3.25	3.25	3.25	0.60					
Dist. Progetto Sottof.												-4.21	-3.85	-3.25	-0.00	-0.00	-3.25	-3.85	-4.02			
Quote Terreno	315.14		316.00			317.83	317.93	318.00	318.00	318.00		318.00		318.41	318.47		318.76		319.48			
Distanze Terreno	-30.00		-24.07			-11.55	-10.92	-10.30	-9.28	-8.31		0.00	1.18			7.30		20.00				

SCAVI E BONIFICHE	
SCOTICO	8.49 m
BONIFICA	5.09 mq

RILEVATI	
RILEVATO	1.86 mq
TERRENO VEGETALE	2.30 m

SOVRASTRUTTURA STRADALE	
STRATO DI USURA	6.50 m
STRATO DI BINDER	6.50 m
STRATO DI BASE	6.50 m
STRATO DI FONDAZIONE	1.14 mq

SEZIONE N. : 90
 Qt. prog. : 318.27
 Progr. Km : 1+780.000

Scala 1:200

Qt. rif. 304.000

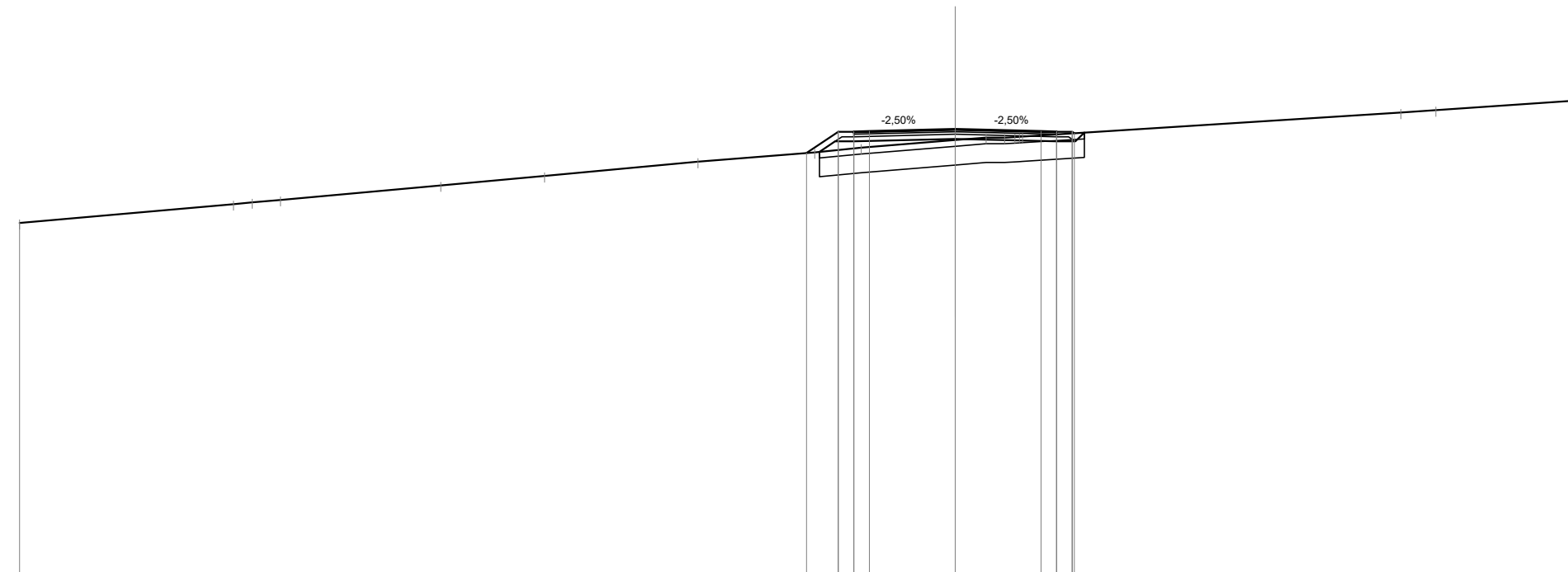

Quote Progetto Pavim.								317.51	318.18	318.15	318.20	318.27	318.20	318.18	318.14														
Dist. Parz. Progetto Pavim.								1.02	0.50	0.50	2.75	2.75	0.50	0.50															
Dist. Progetto Pavim.								-4.77	-3.75	-3.25	-2.75	0.00	-2.75	-3.25	-3.82														
Quote Progetto Sottof.								317.54	317.87	317.87		317.96	317.87	317.87	318.16														
Dist. Parz. Progetto Sottof.								0.50	0.60		3.25	3.25	0.60	0.28															
Dist. Progetto Sottof.								-4.35	-3.85	-3.25		0.00	-3.25	-3.85	-4.14														
Quote Terreno	315.26		315.87	315.92	316.00			316.47		316.77		317.22	317.53	317.67	317.92	318.00	318.03	318.03	318.03						318.80	318.88			319.19
Distanze Terreno	-30.00		-23.14	-22.54	-21.63			-16.49		-13.17		-8.24	-4.50	-3.01	0.00	0.99	1.59	2.06	2.16							14.30	15.41		20.00

SCAVI E BONIFICHE	
SCOTICO	8.77 m
BONIFICA	5.26 mq

RILEVATI	
RILEVATO	2.95 mq
TERRENO VEGETALE	2.68 m

SOVRASTRUTTURA STRADALE	
STRATO DI USURA	6.50 m
STRATO DI BINDER	6.50 m
STRATO DI BASE	6.50 m
STRATO DI FONDAZIONE	1.14 mq

SEZIONE N. : 91
 Qt. prog. : 317.84
 Progr. Km : 1+800.000

Scala 1:200

Qt. rif. 304.000

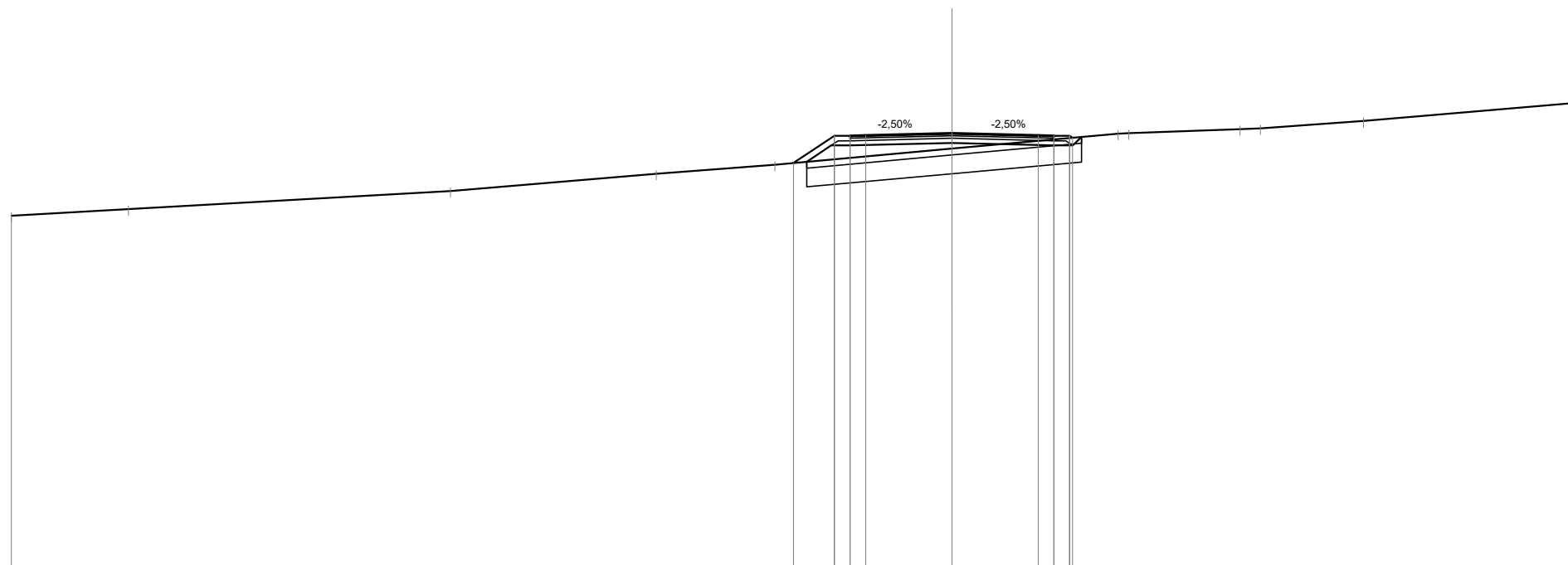

Quote Progetto Pavim.							316.89		317.76		317.84		317.77			
Dist. Parz. Progetto Pavim.							1.30		0.50		2.75		0.50			
Dist. Progetto Pavim.							-5.05		-3.75		0.00		-2.75			
Quote Progetto Sottof.							316.93		317.45		317.53		317.45			
Dist. Parz. Progetto Sottof.							0.78		0.60		3.25		0.60			
Dist. Progetto Sottof.							-4.63		-3.85		0.00		-3.25			
Quote Terreno	315.21	315.43	316.00	316.55	316.84						317.35		317.83			
Distanze Terreno	-30.00	-26.26	-16.00	-9.43	-5.65						0.00		-5.30			

SCAVI E BONIFICHE	
SCOTICO	8.64 m
BONIFICA	5.19 mq

RILEVATI	
RILEVATO	2.48 mq
TERRENO VEGETALE	2.55 m

SOVRASTRUTTURA STRADALE	
STRATO DI USURA	6.50 m
STRATO DI BINDER	6.50 m
STRATO DI BASE	6.50 m
STRATO DI FONDAZIONE	1.14 mq

SEZIONE N. : 92
 Qt. prog. : 317.78
 Progr. Km : 1+820.000

Scala 1:200

Qt. rif. 304.000

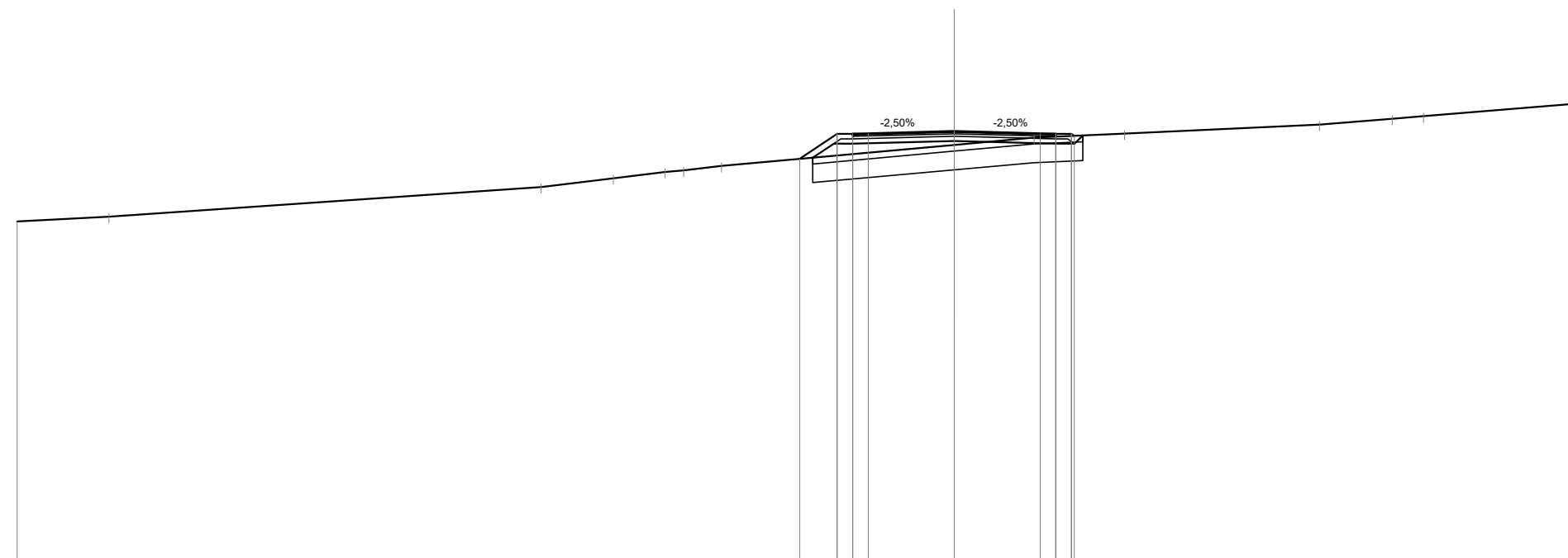

Quote Progetto Pavim.								316.90	317.70	317.67	317.71		317.78		317.71	317.70	317.70	317.64
Dist. Parz. Progetto Pavim.								1.20	0.50	0.50	0.50	2.75	2.75		0.50	0.50		
Dist. Progetto Pavim.								-4.95	-3.75	-3.25	-2.75		0.00		-2.75	-3.25	-3.75	-3.84
Quote Progetto Sottof.								316.94	317.39	317.39			317.47		317.39	317.39	317.65	
Dist. Parz. Progetto Sottof.								0.68	0.60		3.25		3.25		0.60			
Dist. Progetto Sottof.								-4.53	-3.85	-3.25		0.00		-3.25	-3.85	-4.11		
Quote Terreno	314.90	315.05	316.00	316.28	316.48	316.53	316.68						317.35		317.58		317.71	
Distanze Terreno	-30.00	-27.06	-13.23	-10.92	-9.25	-8.66	-7.45						0.00		-2.55		-5.46	

SCAVI E BONIFICHE	
SCOTICO	8.93 m
BONIFICA	5.36 mq

RILEVATI	
RILEVATO	3.60 mq
TERRENO VEGETALE	2.97 m

SOVRASTRUTTURA STRADALE	
STRATO DI USURA	6.50 m
STRATO DI BINDER	6.50 m
STRATO DI BASE	6.50 m
STRATO DI FONDAZIONE	1.14 mq

SEZIONE N. : 93
 Qt. prog. : 317.91
 Progr. Km : 1+840.000

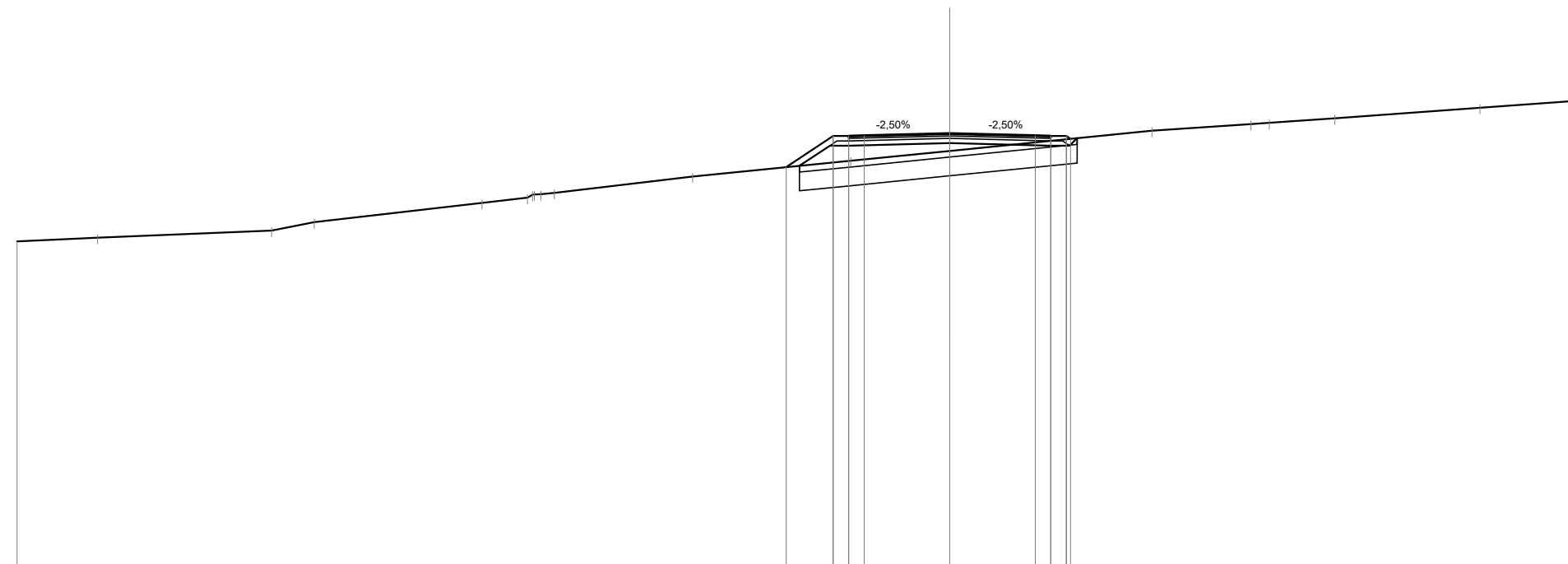

Scala 1:200

Qt. rif. 304.000

Quote Progetto Pavim.									316.82	317.83	317.80	317.84		317.91		317.84	317.83	317.74		
Dist. Parz. Progetto Pavim.									1.50	0.50	0.50	2.75		2.75		0.50	0.50			
Dist. Progetto Pavim.									-5.25	-3.75	-3.25	-2.75		0.00		-2.75	-3.25	-3.89		
Quote Progetto Sottof.									316.87	317.52	317.52			317.60		317.52	317.52	317.76		
Dist. Parz. Progetto Sottof.									0.98	0.60		3.25		3.25		0.60				
Dist. Progetto Sottof.									-4.83	-3.85	-3.25			0.00		-3.25	-3.85	-4.10		
Quote Terreno	314.44	314.56	314.79	315.06	315.68	315.85	316.00	316.53		317.03			317.35		318.00	318.21	318.25	318.39	318.74	318.94
Distanze Terreno	-30.00	-27.41	-21.81	-20.44	-15.04	-13.58	-12.72	-8.27		-3.18			0.00		-6.51	-9.69	-10.28	-12.39	-17.05	-20.00

SCAVI E BONIFICHE	
SCOTICO	8.23 m
BONIFICA	4.93 mq

RILEVATI	
RILEVATO	0.41 mq
TERRENO VEGETALE	1.24 m

SOVRASTRUTTURA STRADALE	
STRATO DI USURA	6.50 m
STRATO DI BINDER	6.50 m
STRATO DI BASE	6.50 m
STRATO DI FONDAZIONE	1.15 mq

SEZIONE N. : 94

Qt. prog. : 318.38

Progr. Km : 1+860.000

Scala 1:200

Qt. rif. 304.000

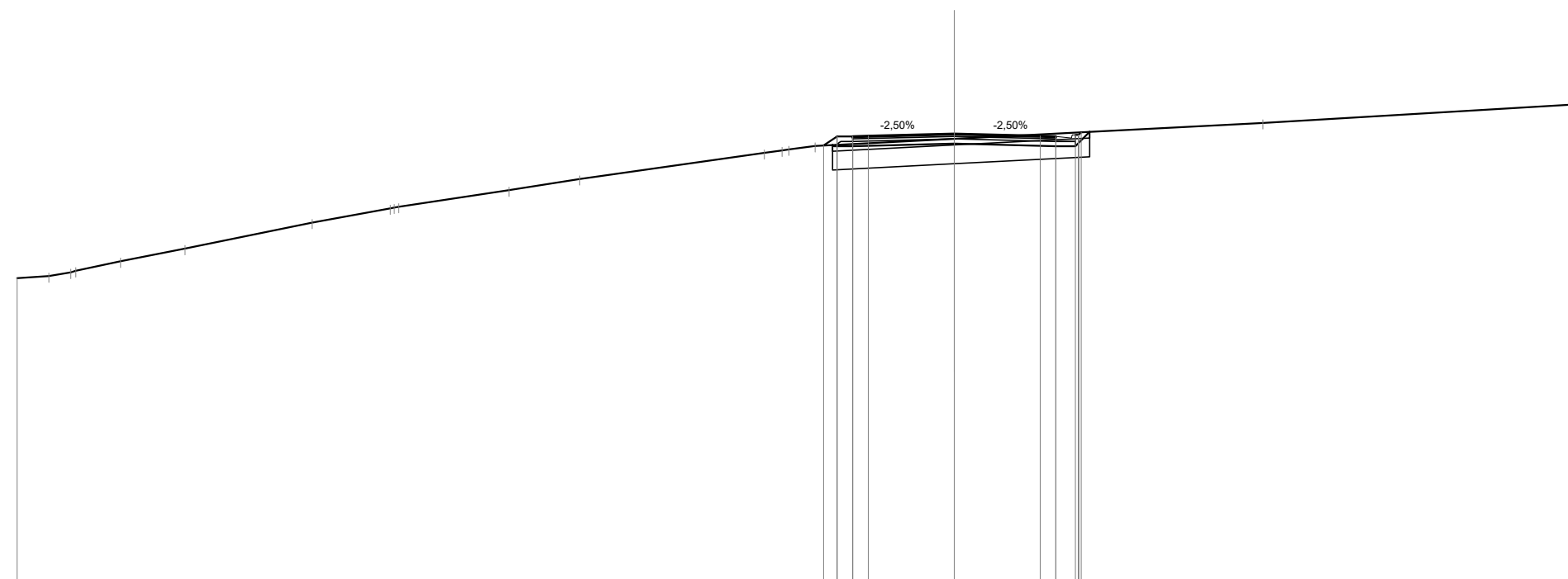

Quote Progetto Pavim.									318.01	318.30	318.27	318.31			318.38		318.31	318.27	318.35	318.44
Dist. Parz. Progetto Pavim.									0.43	0.50	0.50		2.75		2.75		0.50	0.63		318.44
Dist. Progetto Pavim.									4.18	3.75	3.25	2.75			0.00		2.75	3.25	3.88	4.06
Quote Progetto Sottof.									318.03	317.99				318.07			317.99	317.99	318.45	
Dist. Parz. Progetto Sottof.									0.04	0.60			3.25		3.25		0.63	0.46		
Dist. Progetto Sottof.									-3.89	-3.25				0.00			-3.25	-3.88	-4.34	
Quote Terreno	313.76	313.83	313.95	314.00	314.30	314.71	315.54	316.00	316.05	316.58	316.94	317.77	317.86	317.89	318.00	318.23	318.73			319.34
Distanze Terreno	-30.00	-28.98	-28.28	-28.12	-26.69	-24.62	-20.55	-18.05	-17.78	-14.25	-11.99	-6.08	-5.52	-5.29	-4.45	0.00	9.88			20.00

SCAVI E BONIFICHE	
SCOTICO	8.20 m
BONIFICA	4.92 mq

RILEVATI	
RILEVATO	2.20 mq
TERRENO VEGETALE	2.29 m

SOVRASTRUTTURA STRADALE	
STRATO DI USURA	6.50 m
STRATO DI BINDER	6.50 m
STRATO DI BASE	6.50 m
STRATO DI FONDAZIONE	1.14 mq

SEZIONE N. : 95
 Qt. prog. : 318.90
 Progr. Km : 1+880.000

Scala 1:200

Qt. rif. 304.000

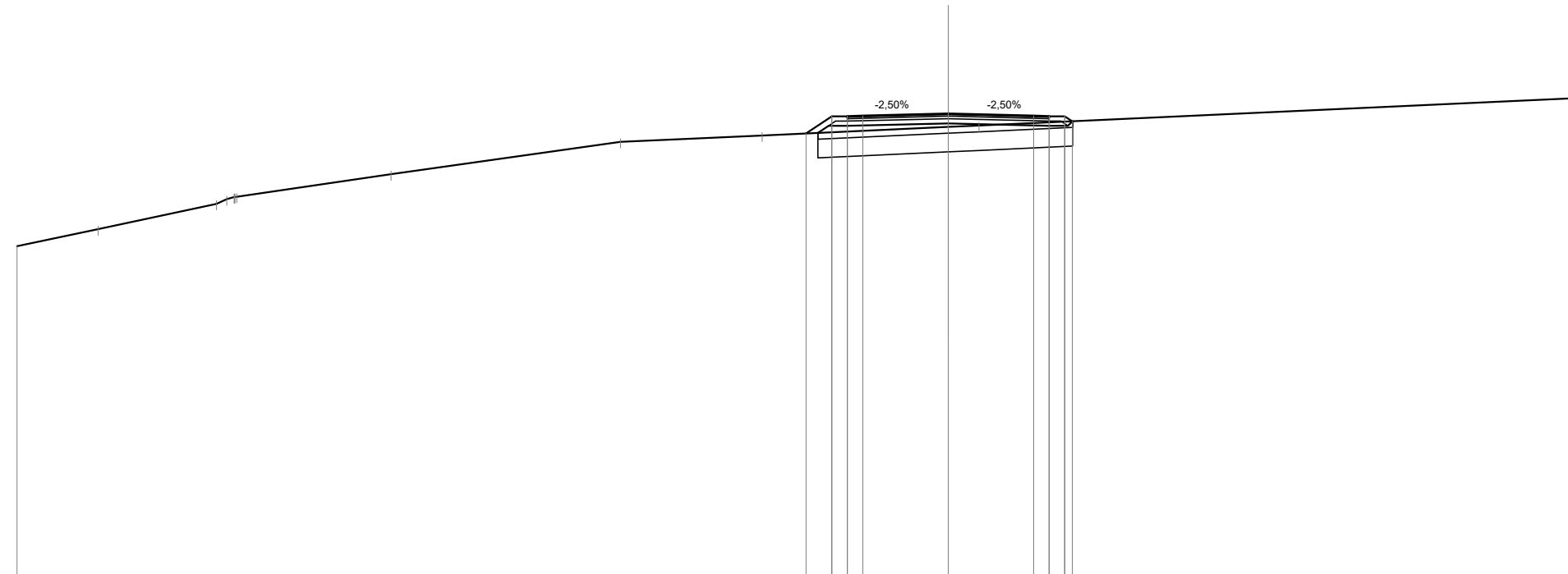

Quote Progetto Pavim.							318.27	318.82	318.79	318.83		318.90		318.83	318.82	318.66	
Dist. Parz. Progetto Pavim.							0.83	0.50	0.50		2.75		2.75	0.50	0.50		
Dist. Progetto Pavim.							-4.58	-3.75	-3.25	-2.75		0.00		-2.75	-3.25	-3.75	-4.00
Quote Progetto Sottof.							318.28	318.51	318.51			318.59		318.51	318.51	318.66	
Dist. Parz. Progetto Sottof.							0.34	0.60		3.25		3.25		0.60			
Dist. Progetto Sottof.							-4.20	-3.85	-3.25			0.00		-3.25	-3.85	-4.00	
Quote Terreno	314.64	315.18	316.00	316.22	316.23								318.48	318.52			
Distanze Terreno	-30.00	-27.38	-23.57	-23.00	-22.92								-10.56	-6.00	-0.00	-0.99	20.00

SCAVI E BONIFICHE	
SCOTICO	8.14 m
BONIFICA	4.89 mq

RILEVATI	
RILEVATO	1.99 mq
TERRENO VEGETALE	2.19 m

SOVRASTRUTTURA STRADALE	
STRATO DI USURA	6.50 m
STRATO DI BINDER	6.50 m
STRATO DI BASE	6.50 m
STRATO DI FONDAZIONE	1.14 mq

SEZIONE N. : 96
 Qt. prog. : 319.38
 Progr. Km : 1+900.000

Scala 1:200

Qt. rif. 305.000

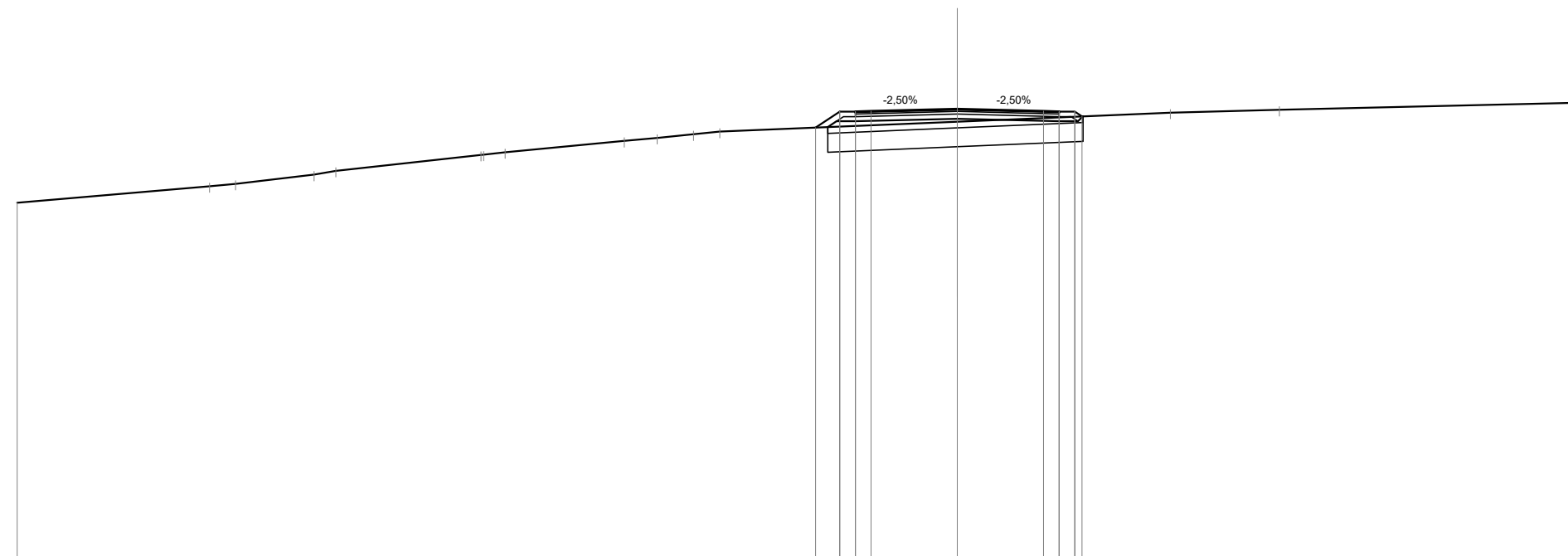

Quote Progetto Pavim.							318.78	319.30	319.27	319.31		319.38		319.31	319.30	319.30	319.14		
Dist. Parz. Progetto Pavim.							0.77	0.50	0.50	2.75		2.75		0.50	0.50				
Dist. Progetto Pavim.							-4.52	-3.75	-3.25	-2.75		0.00		-2.75	-3.25	-3.75	-3.98		
Quote Progetto Sottof.							318.80	318.99	318.99			319.07		318.99	318.99	319.15			
Dist. Parz. Progetto Sottof.							0.28	0.60		3.25		3.25		0.60					
Dist. Progetto Sottof.							-4.13	-3.85	-3.25			0.00		-3.25	-3.85	-4.01			
Quote Terreno	316.39		316.92	316.99	317.29	317.41		317.92	317.92	318.00		318.36	318.46	318.57	318.65		319.26	319.35	319.58
Distanze Terreno	-30.00		-23.86	-23.02	-20.52	-19.83		-15.20	-15.11	-14.42		-10.63	-9.57	-8.42	-7.58		-6.80	-10.28	-20.00

SCAVI E BONIFICHE	
SCOTICO	7.98 m
BONIFICA	4.79 mq

RILEVATI	
RILEVATO	1.60 mq
TERRENO VEGETALE	1.65 m

SOVRASTRUTTURA STRADALE	
STRATO DI USURA	6.50 m
STRATO DI BINDER	6.50 m
STRATO DI BASE	6.50 m
STRATO DI FONDAZIONE	1.14 mq

SEZIONE N. : 97

Qt. prog. : 319.37

Progr. Km : 1+920.000

Scala 1:200

Qt. rif. 305.000

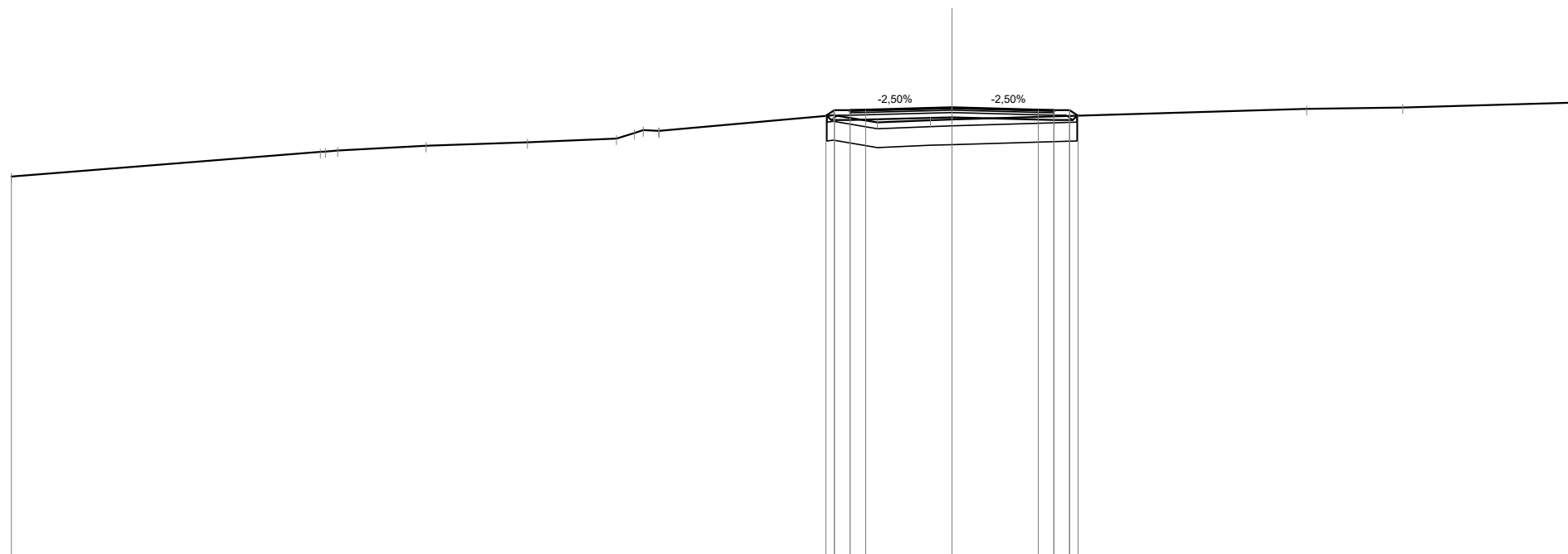

Quote Progetto Pavim.									319.10		319.37		319.30		319.28		
Dist. Parz. Progetto Pavim.									0.50		2.75		0.50		0.50		
Dist. Progetto Pavim.									-4.02		0.00		-2.75		-3.25		
Quote Progetto Sottof.									319.11		319.06		318.97		319.10		
Dist. Parz. Progetto Sottof.									0.13		3.25		0.60		0.60		
Dist. Progetto Sottof.									-3.99		0.00		-3.25		-3.25		
Quote Terreno									317.17		318.89		318.96		318.62		
Distanze Terreno									-30.00		-3.78		-0.69		-9.35		

SCAVI E BONIFICHE	
SCOTICO	7.79 m
BONIFICA	4.67 mq

RILEVATI	
RILEVATO	1.78 mq
TERRENO VEGETALE	2.23 m

SOVRASTRUTTURA STRADALE	
STRATO DI USURA	6.50 m
STRATO DI BINDER	6.50 m
STRATO DI BASE	6.50 m
STRATO DI FONDAZIONE	1.14 mq

SEZIONE N. : 99
 Qt. prog. : 319.06
 Progr. Km : 1+960.000

Scala 1:200

Qt. rif. 305.000

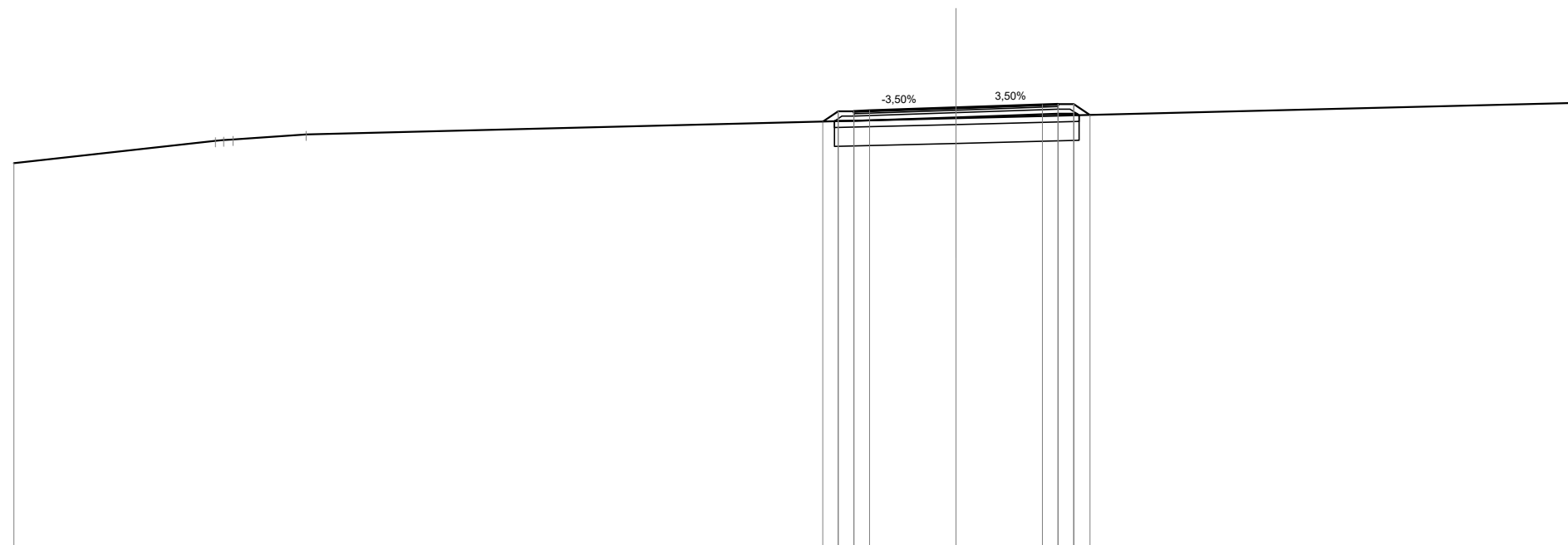

Quote Progetto Pavim.				318.61	318.94	318.91	318.96	319.06	319.15	319.17	318.82
Dist. Parz. Progetto Pavim.				0.50	0.50	0.50	2.75	2.75	0.50	0.50	0.52
Dist. Progetto Pavim.				-4.25	-3.75	-3.25	-2.75	0.00	-2.75	-3.25	-4.27
Quote Progetto Sottof.				318.62	318.63	318.75	318.81	318.75	318.86	318.86	318.81
Dist. Parz. Progetto Sottof.				0.02	0.60	3.25	3.25	3.25	0.60	3.85	3.92
Dist. Progetto Sottof.				-3.87	-3.25	0.00	0.00	0.00	-3.25	3.85	3.92
Quote Terreno	317.28	318.00	318.04	318.20				318.72			319.21
Distanze Terreno	-30.00	-23.58	-23.02	-20.69				0.00			19.88

SCAVI E BONIFICHE	
SCOTICO	8.10 m
BONIFICA	4.86 mq
RILEVATI	
RILEVATO	2.64 mq
TERRENO VEGETALE	2.58 m
SOVRASTRUTTURA STRADALE	
STRATO DI USURA	6.50 m
STRATO DI BINDER	6.50 m
STRATO DI BASE	6.50 m
STRATO DI FONDAZIONE	1.14 mq

SEZIONE N. : 100
 Qt. prog. : 318.45
 Progr. Km : 1+980.000

Scala 1:200

Qt. rif. 305.000

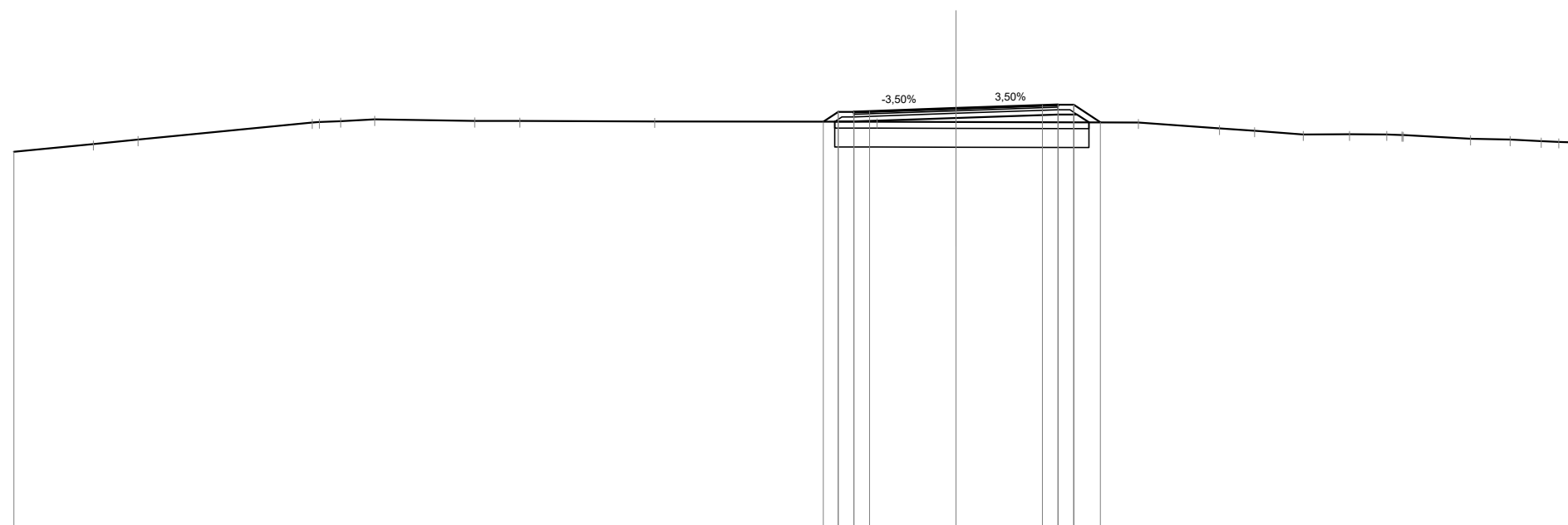

Quote Progetto Pavim.							318.02	318.34	318.31	318.36		318.45		318.55	318.57	318.57	318.00										
Dist. Parz. Progetto Pavim.							0.47	0.50	0.50		2.75		2.75	0.50	0.50	0.84											
Dist. Progetto Pavim.							-4.22	-3.75	-3.25	-2.75		0.00		-2.75	-3.25	-3.75	-4.59										
Quote Progetto Sottof.							318.02	318.03				318.14			318.26	318.26	318.00										
Dist. Parz. Progetto Sottof.							0.01	0.60		3.25		3.25		0.60	0.38												
Dist. Progetto Sottof.							-3.86	-3.25			0.00			-3.25	-3.85	-4.23											
Quote Terreno	317.06	317.31	317.46		318.00	318.01	318.04	318.05	318.04		318.02	318.01		318.00													
Distanze Terreno	-30.00	-27.47	-26.04		-20.49	-20.27	-19.59	-18.51	-15.32	-13.88	-9.59	-2.52	0.00		-5.81	-8.39	-9.50	-11.06	-12.53	-13.72	-14.20	-14.24	-16.38	-17.64	-18.63	-19.19	-20.00

SCAVI E BONIFICHE	
SCOTICO	8.63 m
BONIFICA	5.18 mq

RILEVATI	
RILEVATO	1.67 mq
TERRENO VEGETALE	1.88 m

SOVRASTRUTTURA STRADALE	
STRATO DI USURA	6.50 m
STRATO DI BINDER	6.50 m
STRATO DI BASE	6.50 m
STRATO DI FONDAZIONE	1.15 mq

SEZIONE N. : 101

Qt. prog. : 317.75

Progr. Km : 2+000.000

Scala 1:200

Qt. rif. 304.000

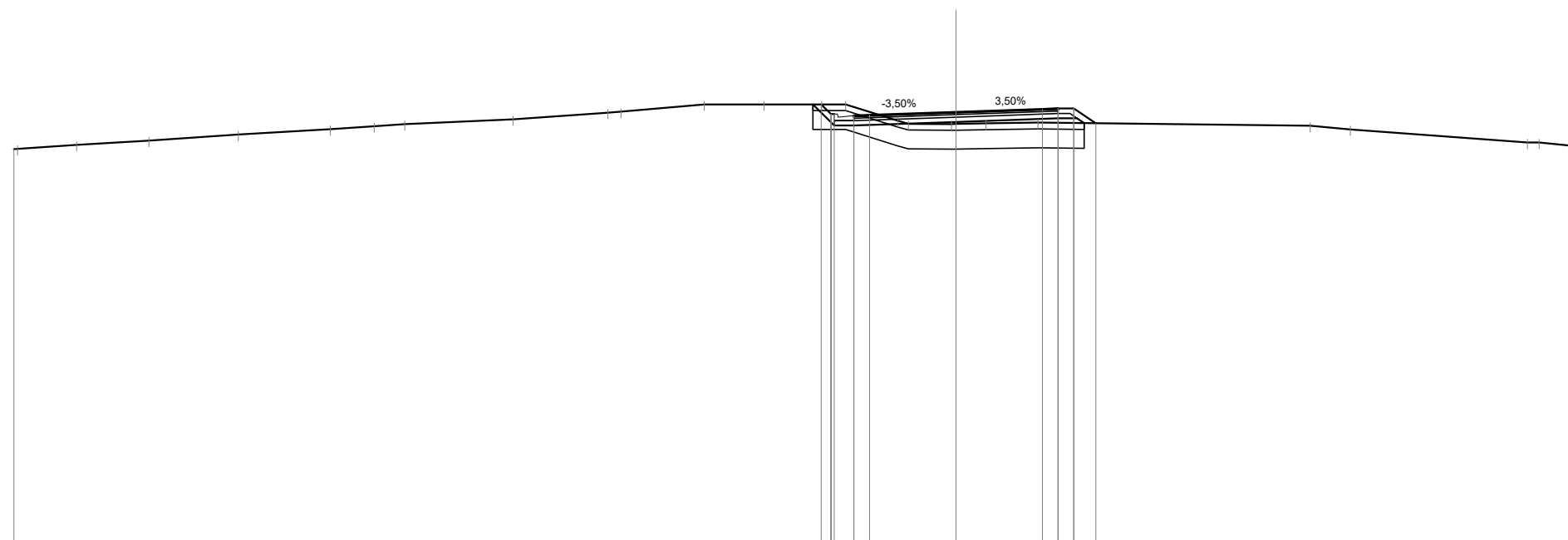

Quote Progetto Pavim.															318.00	317.69	317.64	317.66		317.75		317.85	317.87	317.40					
Dist. Parz. Progetto Pavim.															0.63	0.50				2.75		2.75		0.50	0.50	0.70			
Dist. Progetto Pavim.															4.29	3.98	3.88	3.25			0.00		2.75	3.25	3.75	4.45			
Quote Progetto Sottof.															318.00	317.33	317.33				317.44		317.56	317.56	317.40				
Dist. Parz. Progetto Sottof.															0.67	0.63		3.25				3.25		0.60					
Dist. Progetto Sottof.															4.55	3.88	3.25				0.00		3.25	3.85	4.08				
Quote Terreno	316.57	316.58	316.71	316.85	317.04	317.21	317.30	317.37	317.53	317.74	317.76	318.00	318.00	318.00	318.00	318.00	317.48	317.38	317.37	317.38	317.40	317.42			317.32	317.20	316.79	316.79	316.64
Distanze Terreno	30.00	29.88	28.00	25.69	22.85	19.92	18.52	17.55	14.10	11.08	10.66	8.02	6.12	4.28	3.52	1.85	1.51	0.14	0.00	0.95	2.61			11.27	12.55	18.20	18.56	20.00	

SCAVI E BONIFICHE	
SCOTICO	13.61 m
BONIFICA	8.15 mq
RILEVATI	
RILEVATO	12.85 mq
TERRENO VEGETALE	9.23 m
SOVRASTRUTTURA STRADALE	
STRATO DI USURA	6.50 m
STRATO DI BINDER	6.50 m
STRATO DI BASE	6.50 m
STRATO DI FONDAZIONE	1.14 mq

SEZIONE N. : 103
 Qt. prog. : 315.60
 Progr. Km : 2+040.000

Scala 1:200

Qt. rif. 301.000

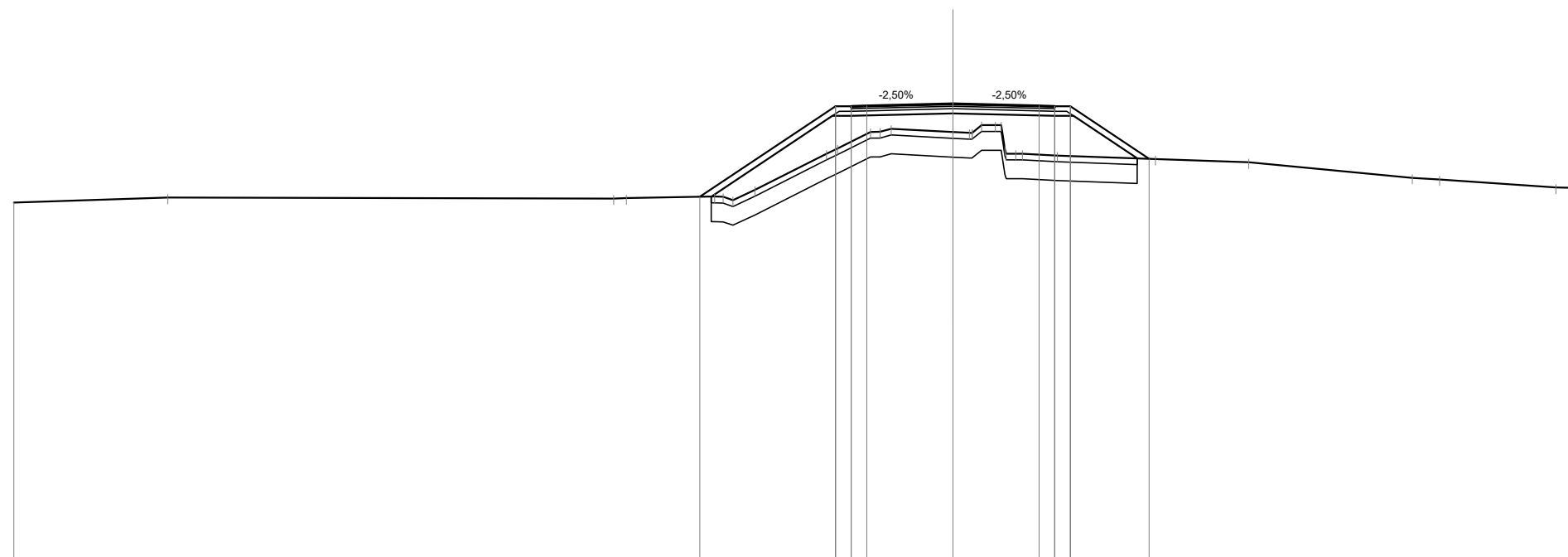

Quote Progetto Pavim.				312.62					315.52	315.49	315.53		315.60			315.53	315.52	315.52		313.84	
Dist. Parz. Progetto Pavim.					4.34				0.50	0.50		2.75		2.75		0.50	0.50		2.51		
Dist. Progetto Pavim.																					
Quote Progetto Sottof.					312.63				315.21	315.21			315.29			315.21	315.21		313.85		
Dist. Parz. Progetto Sottof.					3.86				0.60		3.25				3.25	0.60	2.03				
Dist. Progetto Sottof.																					
Quote Terreno	312.44				312.63				314.00	314.17			314.69			313.94				313.83	
Distanze Terreno	30.00				7.61				4.04	3.68			2.63		1.97					6.46	

SCAVI E BONIFICHE	
SCOTICO	13.17 m
BONIFICA	7.88 mq

RILEVATI	
RILEVATO	11.66 mq
TERRENO VEGETALE	8.64 m

SOVRASTRUTTURA STRADALE	
STRATO DI USURA	6.50 m
STRATO DI BINDER	6.50 m
STRATO DI BASE	6.50 m
STRATO DI FONDAZIONE	1.14 mq

SEZIONE N. : 104
 Qt. prog. : 315.22
 Progr. Km : 2+060.000

Scala 1:200

Qt. rif. 300.000

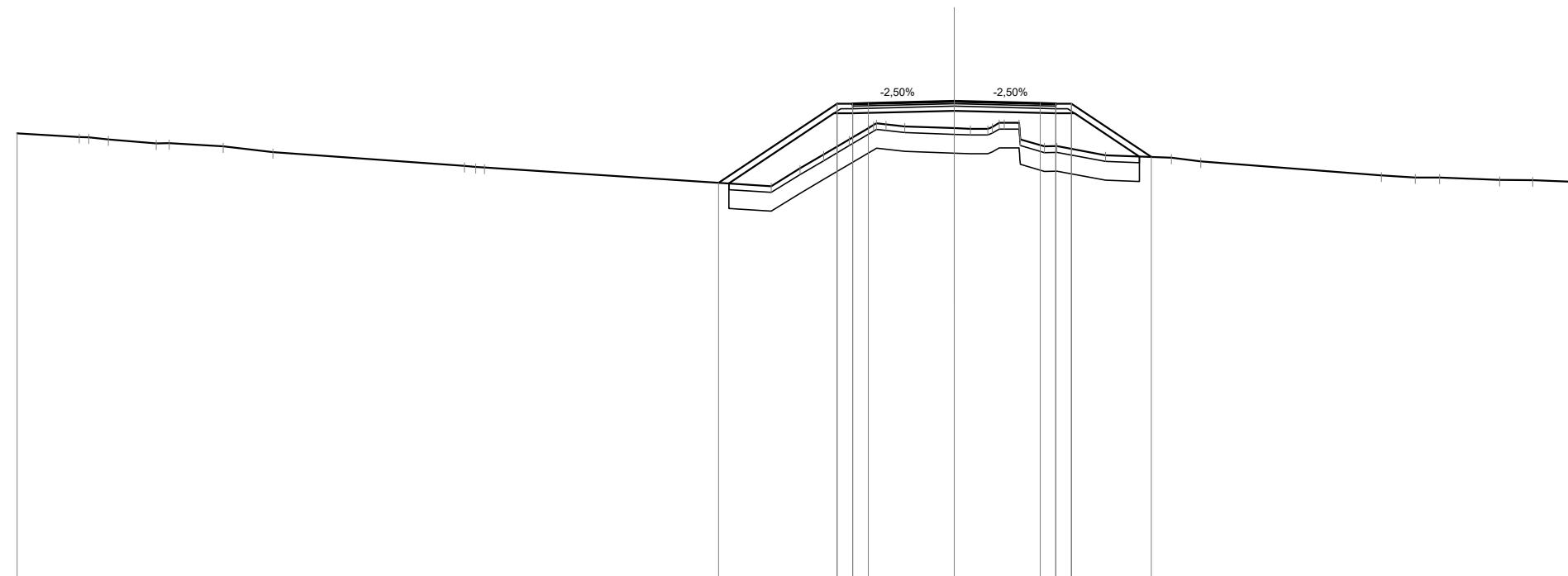

Quote Progetto Pavim.					312.61	315.14	315.11	315.15	315.22	315.15	315.14	315.14	313.43																									
Dist. Parz. Progetto Pavim.					3.80	0.50	0.50	2.75	2.75	0.50	0.50	2.56																										
Dist. Progetto Pavim.					-7.55	-3.75	-3.25	-2.75	0.00	-2.75	-3.25	-3.75	-6.31																									
Quote Progetto Sottof.					312.59	314.83	314.83		314.91	314.83	314.83	313.45																										
Dist. Parz. Progetto Sottof.					3.36	0.60		3.25	3.25	0.60	2.07																											
Dist. Progetto Sottof.					-7.22	-3.85	-3.25		0.00	-3.25	-3.85	-5.93																										
Quote Terreno	314.19	314.07	314.00	313.87	313.88	313.78	313.59		313.15	313.10			312.50	313.07	313.51	314.00	314.36	314.48	314.42	314.36	314.34	314.34	314.53	314.53	314.00	313.78	313.49	313.41	313.29		312.84	312.78	312.78	312.70	312.69	312.63		
Distanze Terreno	-30.00	-28.00	-27.07	-25.54	-25.13	-23.40	-21.81		-15.68	-15.03				-5.86	-4.93	-4.18	-3.36	-2.75	-2.18	-1.58		0.00	0.52	1.08	1.60	2.07	2.12	3.28	4.84	6.95	7.89		13.67	14.76	15.53	17.46	18.52	20.00

SCAVI E BONIFICHE	
SCOTICO	11.53 m
BONIFICA	6.92 mq

RILEVATI	
RILEVATO	8.70 mq
TERRENO VEGETALE	6.80 m

SOVRASTRUTTURA STRADALE	
STRATO DI USURA	6.50 m
STRATO DI BINDER	6.50 m
STRATO DI BASE	6.50 m
STRATO DI FONDAZIONE	1.14 mq

SEZIONE N. : 105
 Qt. prog. : 315.85
 Progr. Km : 2+080.000

Scala 1:200

Qt. rif. 302.000

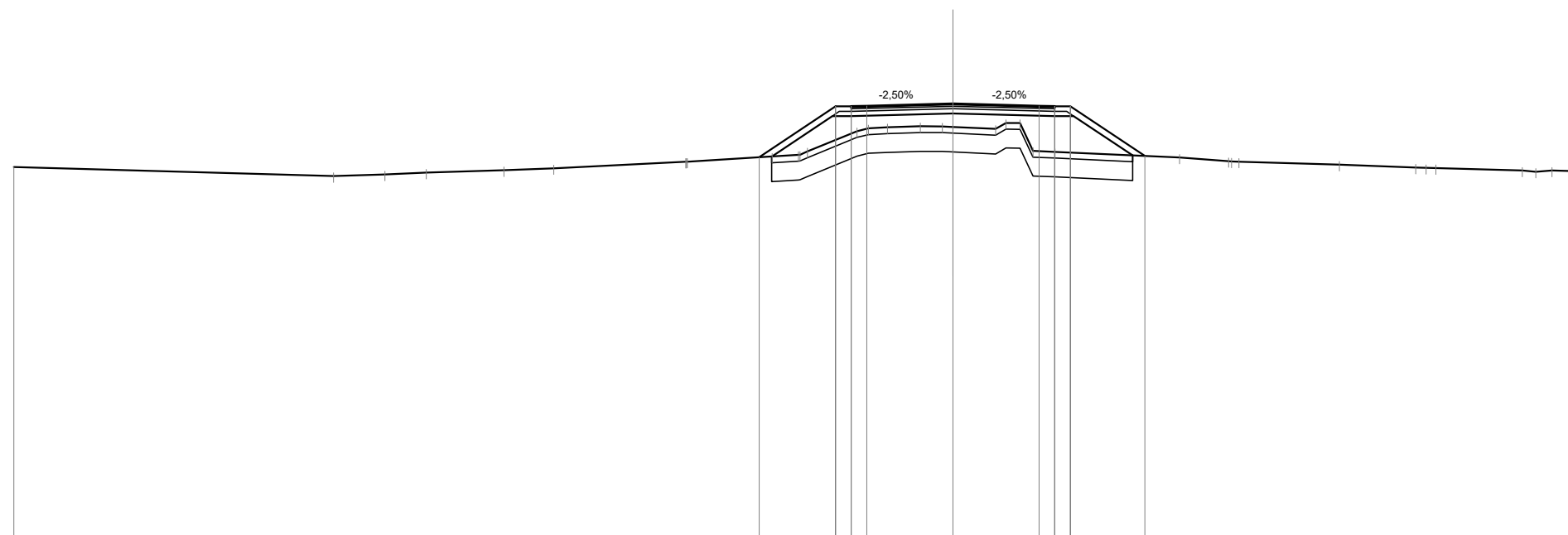

Quote Progetto Pavim.									314.14	315.77	315.74	315.78		315.85	315.78	315.77	315.77	314.18																
Dist. Parz. Progetto Pavim.									2.44	0.50	0.50	2.75		2.75	0.50	0.50	2.38																	
Dist. Progetto Pavim.									-6.19	-3.75	-3.25	-2.75		0.00	-2.75	-3.25	-3.75	-6.13																
Quote Progetto Sottof.									314.16	315.46	315.46		315.54		315.46	315.46	314.20																	
Dist. Parz. Progetto Sottof.									1.94	0.60		3.25		3.25	0.60	1.89																		
Dist. Progetto Sottof.									-5.80	-3.85	-3.25		0.00		-3.25	-3.85	-5.74																	
Quote Terreno	313.83								314.00	314.00	314.16	314.22	314.33	314.97	315.10	315.13	315.13	315.11	315.05	315.23	314.35	314.32		314.13	314.02	314.00		313.91	313.81	313.79		313.72	313.72	313.70
Distanze Terreno	-30.00								-8.54	-8.48	-5.77	-4.93	-4.65	-3.07	-2.09	-1.04	-0.34	0.00	1.36	2.14	2.56	3.26		7.24	8.81	9.14		12.35	14.78	15.43		18.19	19.14	20.00

SCAVI E BONIFICHE	
SCOTICO	8.13 m
BONIFICA	4.90 mq

RILEVATI	
RILEVATO	1.80 mq
TERRENO VEGETALE	2.08 m

SOVRASTRUTTURA STRADALE	
STRATO DI USURA	6.80 m
STRATO DI BINDER	6.80 m
STRATO DI BASE	6.80 m
STRATO DI FONDAZIONE	1.18 mq

SEZIONE N. : 107
 Qt. prog. : 318.61
 Progr. Km : 2+120.000

Scala 1:200

Qt. rif. 305.000

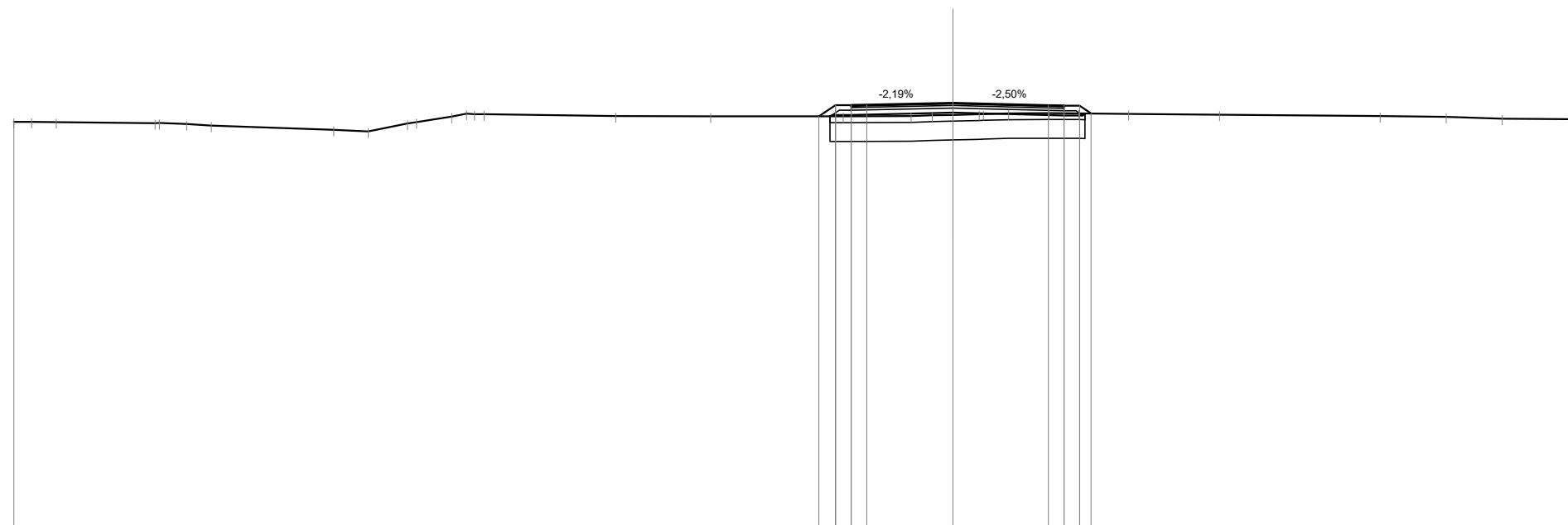

Quote Progetto Pavim.						318.18	318.54	318.51	318.55		318.61		318.53	318.52	318.52	318.28																	
Dist. Parz. Progetto Pavim.						0.54	0.50	0.50	2.75		3.04		0.50	0.50	0.37																		
Dist. Progetto Pavim.						-4.29	-3.75	-3.25			0.00		-3.04	-3.54	-4.04	-4.41																	
Quote Progetto Sottof.						318.18	318.23			318.30			318.21	318.21	318.28																		
Dist. Parz. Progetto Sottof.						0.07	0.60		3.25		3.54		0.60																				
Dist. Progetto Sottof.						-3.93	-3.25			0.00		-3.54	-4.15	-4.21																			
Quote Terreno	318.01	318.01	318.00			317.97	317.94	317.89		317.75	317.70	317.95	318.00	318.18	318.27	318.25		318.19	318.18	318.19	318.17	318.11	318.09										
Distanze Terreno	-30.00	-29.43	-28.65	-25.48	-25.35	-24.48	-23.69		-19.78	-18.68	-17.42	-17.13	-16.01	-15.53	-14.98		-10.77	-7.73	-3.50	-1.34	-0.66	0.00	0.84	0.97	1.78	3.07	4.02	5.61	8.52	13.65	15.75	17.54	20.00

SCAVI E BONIFICHE	
SCOTICO	9.01 m
BONIFICA	5.40 mq

RILEVATI	
RILEVATO	2.54 mq
TERRENO VEGETALE	2.56 m

SOVRASTRUTTURA STRADALE	
STRATO DI USURA	7.50 m
STRATO DI BINDER	7.50 m
STRATO DI BASE	7.50 m
STRATO DI FONDAZIONE	1.29 mq

SEZIONE N. : 108
 Qt. prog. : 319.67
 Progr. Km : 2+140.000

Scala 1:200

Qt. rif. 306.000

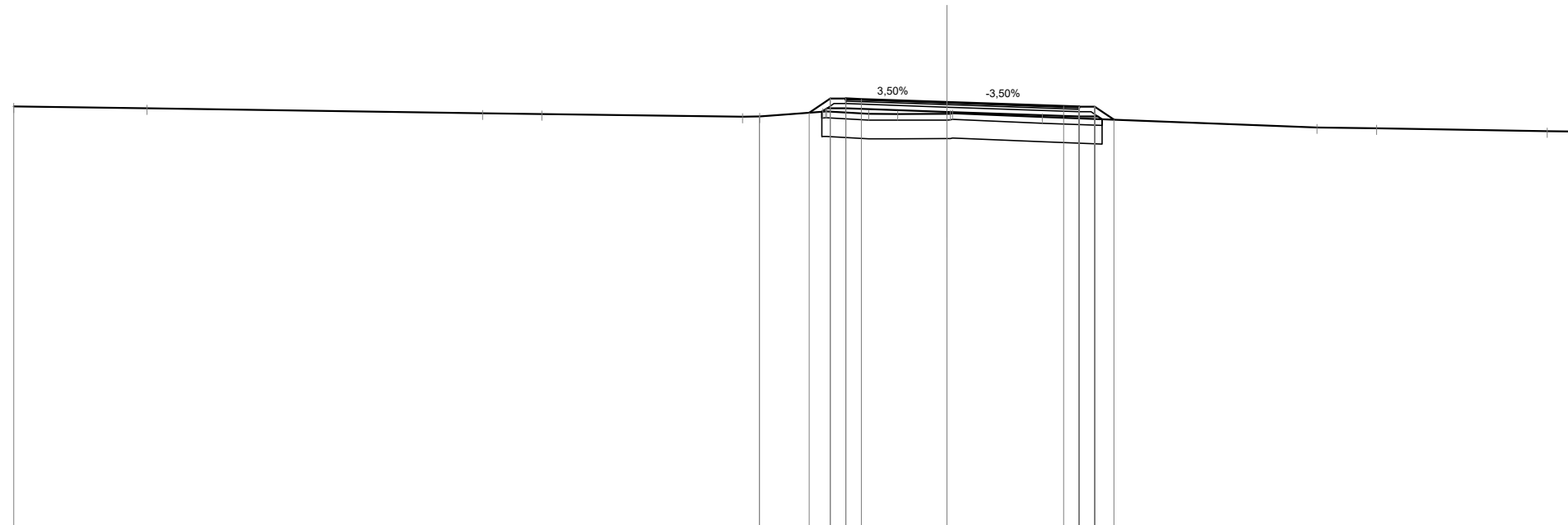

Quote Progetto Pavim.							319.33	319.78	319.75	319.76	319.67	319.54	319.52	319.52	319.10
Dist. Parz. Progetto Pavim.							0.68	0.50	0.50	2.75	3.75	0.50	0.50	0.62	
Dist. Progetto Pavim.							-4.43	-3.75	-3.25	-2.75	0.00	-3.75	-4.25	-4.75	-5.37
Quote Progetto Sottof.							319.36	319.47	319.29	319.36	319.36	319.21	319.21	319.12	
Dist. Parz. Progetto Sottof.							0.17	0.60	3.25	4.25	0.60	4.25	4.85	4.99	
Dist. Progetto Sottof.							-4.02	-3.25	-0.00	-4.25	-4.85	-4.99			
Quote Terreno	319.53	319.47	319.31	319.28	319.20	319.21	319.36	319.37	319.29	319.29	319.30	319.19	318.86	318.83	318.73
Distanze Terreno	-30.00	-25.71	-14.93	-13.02	-6.57	-6.03	-3.99	-3.87	-2.52	-1.59	0.00	-3.06	-11.90	-13.81	-19.29

SCAVI E BONIFICHE	
SCOTICO	8.22 m
BONIFICA	4.93 mq

RILEVATI	
RILEVATO	2.18 mq
TERRENO VEGETALE	2.21 m

SOVRASTRUTTURA STRADALE	
STRATO DI USURA	6.93 m
STRATO DI BINDER	6.93 m
STRATO DI BASE	6.93 m
STRATO DI FONDAZIONE	1.20 mq

SEZIONE N. : 111
 Qt. prog. : 319.15
 Progr. Km : 2+200.000

Scala 1:200

Qt. rif. 307.000

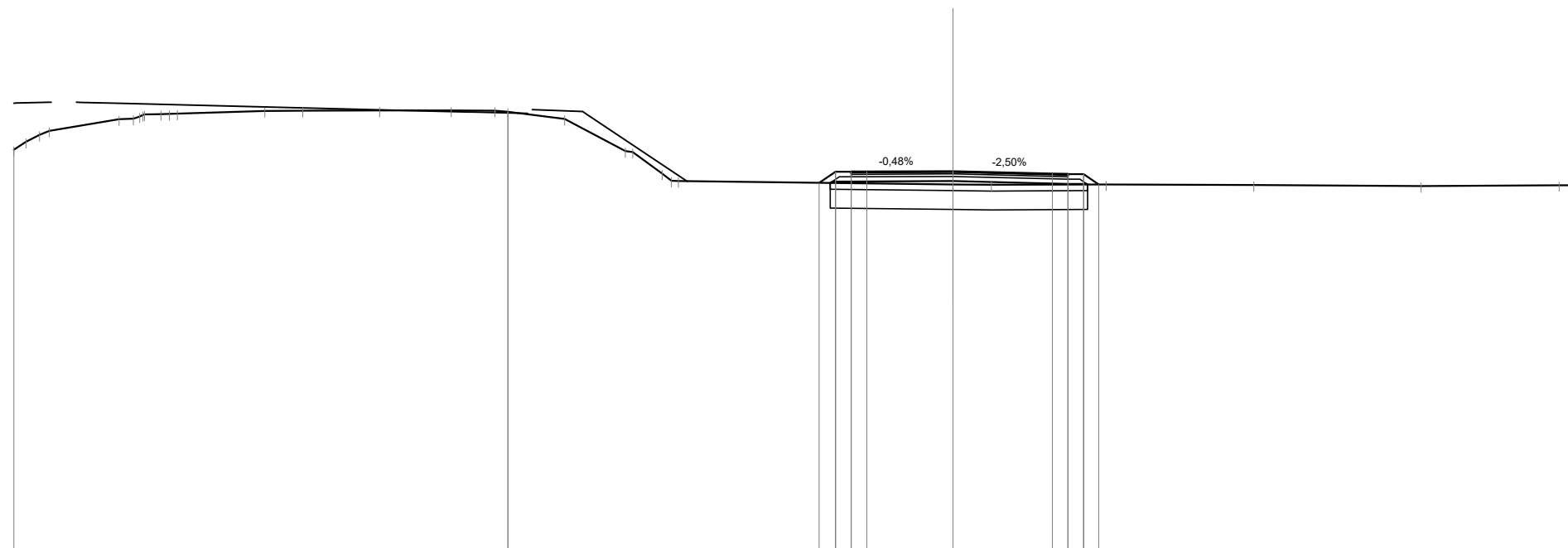

Quote Progetto Pavim.							318.78	319.13	319.10	319.13		319.15		319.07	319.05	319.05	318.73								
Dist. Parz. Progetto Pavim.							0.52	0.50	0.50	2.75		3.18		0.50	0.50	0.48									
Dist. Progetto Pavim.							-4.27	-3.75	-3.25			0.00		-3.18	-3.68	-4.18	-4.66								
Quote Progetto Sottof.							318.78	318.82			318.84	318.84		318.74	318.74	318.73									
Dist. Parz. Progetto Sottof.							0.06	0.60	3.25		3.68		0.60												
Dist. Progetto Sottof.							-3.92	-3.25			0.00		-3.68	-4.28	-4.30										
Quote Terreno	319.83	320.09	320.44	320.81	320.83	320.97	320.99	321.07	321.08	321.09	321.08	320.82	319.79	319.76	319.08	318.84	318.73	318.72	318.71	318.67	318.71	318.70			
Distanze Terreno	-30.00	-29.61	-28.86	-26.64	-26.18	-25.30	-24.77	-21.98	-20.76	-18.32	-16.03	-14.63	-14.21	-12.40	-10.46	-10.23	-9.29	-8.77	-0.00	-1.23	-4.89	-9.61	-14.95	-19.36	-20.00

SCAVI E BONIFICHE	
SCOTICO	7.81 m
BONIFICA	4.68 mq

RILEVATI	
RILEVATO	1.43 mq
TERRENO VEGETALE	1.95 m

SOVRASTRUTTURA STRADALE	
STRATO DI USURA	6.50 m
STRATO DI BINDER	6.50 m
STRATO DI BASE	6.50 m
STRATO DI FONDAZIONE	1.14 mq

SEZIONE N. : 112

Qt. prog. : 317.82

Progr. Km : 2+220.000

Scala 1:200

Qt. rif. 306.000

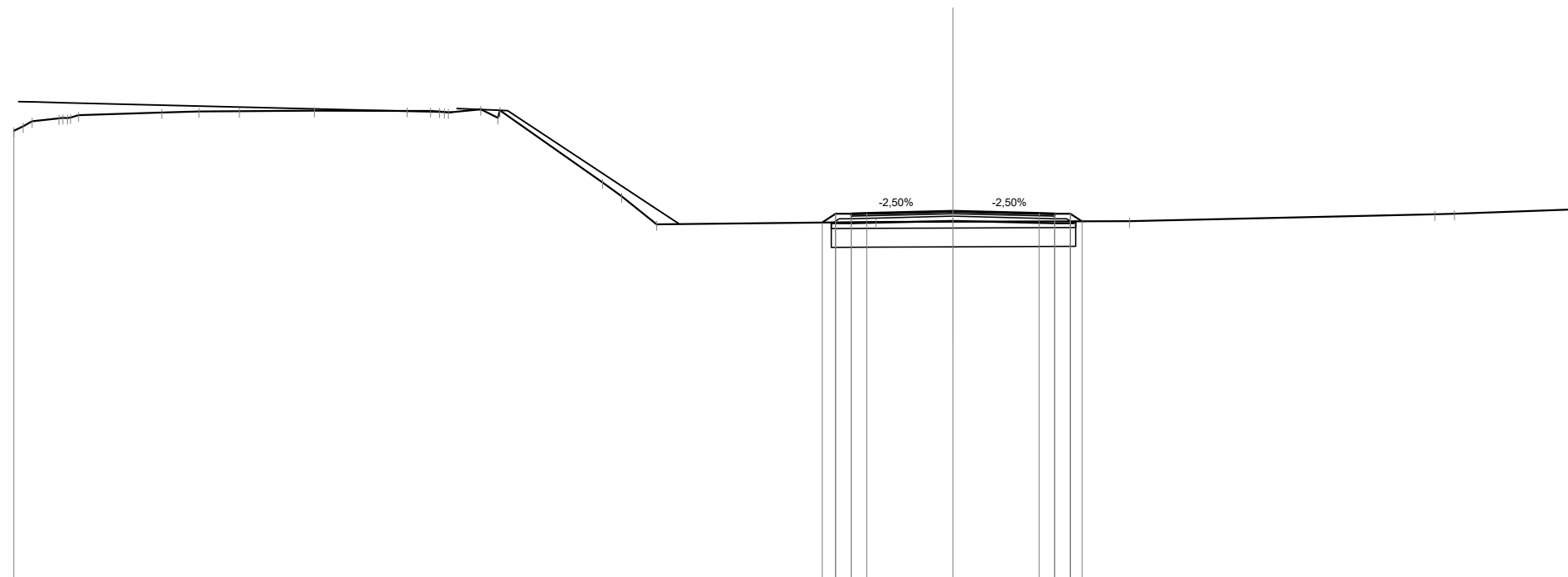

Quote Progetto Pavim.								317.46	317.74	317.71	317.75	317.82	317.75	317.74	317.49										
Dist. Parz. Progetto Pavim.								0.43	0.50	0.50	2.75	2.75	0.50	0.50	0.37										
Dist. Progetto Pavim.								4.18	3.75	3.25	2.75	0.00	2.75	3.25	3.75	4.12									
Quote Progetto Sottof.								317.46	317.43			317.51		317.43	317.43	317.49									
Dist. Parz. Progetto Sottof.								0.03	0.60	3.25		3.25		0.60											
Dist. Progetto Sottof.								3.88	3.25			0.00		3.25	3.85	3.92									
Quote Terreno	320.39	320.53	320.69	320.78	320.88	320.97	321.01	321.01	321.03	321.02	321.02	320.99	320.97	321.08	320.80	320.80	318.74	318.30	317.40	317.48	317.50	317.72	317.73	317.88	
Distanze Terreno	-30.00	-29.70	-29.41	-28.56	-27.93	-25.27	-24.08	-22.79	-20.40	-17.43	-16.69	-16.24	-16.12	-15.08	-14.54	-14.47	-11.19	-10.58	-9.46	-2.47	0.00	5.64	15.39	16.01	20.00

SCAVI E BONIFICHE	
SCOTICO	9.56 m
BONIFICA	5.74 mq

RILEVATI	
RILEVATO	7.78 mq
TERRENO VEGETALE	4.30 m

SOVRASTRUTTURA STRADALE	
STRATO DI USURA	6.50 m
STRATO DI BINDER	6.50 m
STRATO DI BASE	6.50 m
STRATO DI FONDAZIONE	1.14 mq

SEZIONE N. : 113

Qt. prog. : 316.64

Progr. Km : 2+240.000

Scala 1:200

Qt. rif. 305.000

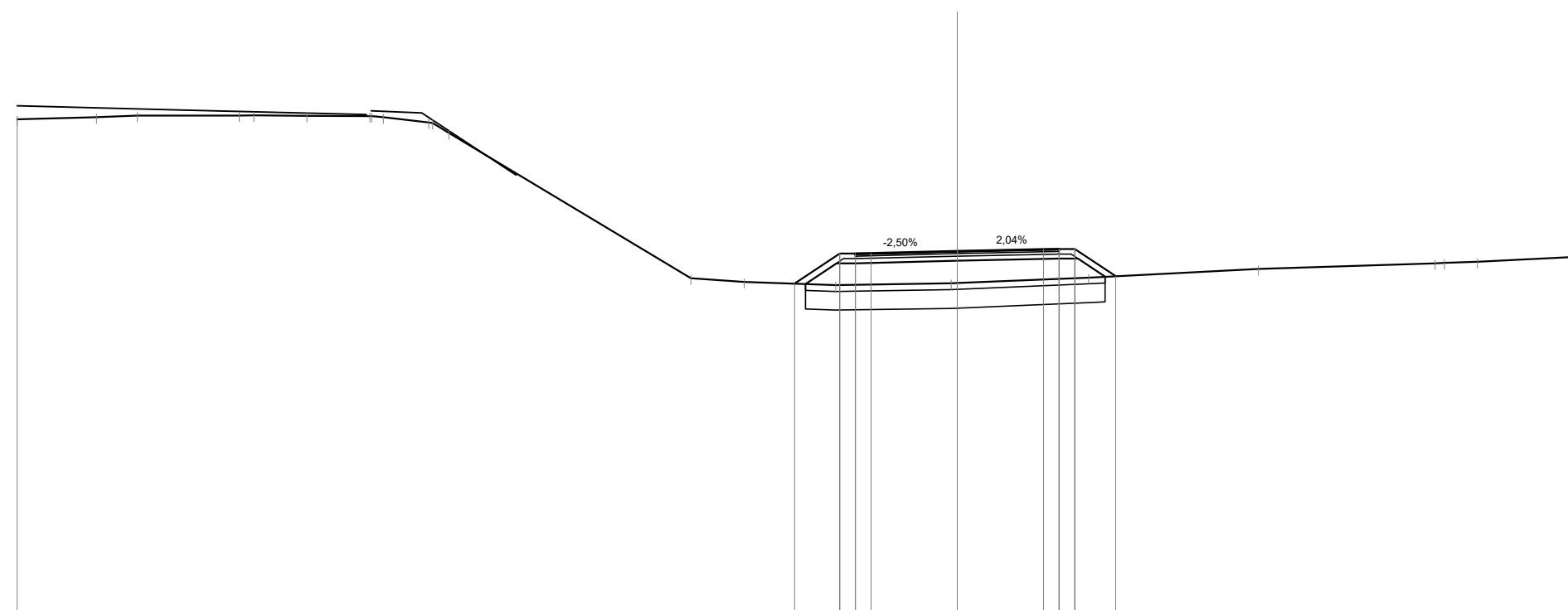

Quote Progetto Pavim.																					315.60	316.56	316.53	316.57		316.64		316.69	316.70	316.70	315.84							
Dist. Parz. Progetto Pavim.																					1.44	0.50	0.50		2.75		2.75	0.50	0.50	1.30								
Dist. Progetto Pavim.																					-5.19	-3.75	-3.25		-2.75		0.00		-2.75	-3.25	-3.75	-5.05						
Quote Progetto Sottof.																					315.59	316.25	316.25				316.33		316.39	316.39	315.82							
Dist. Parz. Progetto Sottof.																					0.99	0.60			3.25		3.25		0.60	0.66								
Dist. Progetto Sottof.																					-4.84	-3.85	-3.25			0.00		-3.25	-3.85	-4.72								
Quote Terreno	320.84	320.91	320.96	320.96	320.96	320.95	320.91	320.74	320.40		315.77	315.65		315.55	315.62	315.61	315.79	316.07		316.25	316.26	316.29	316.47															
Distanze Terreno	-30.00	-27.47	-26.17	-22.91	-22.44	-20.75	-18.75	-18.31	-16.86	-16.21	-8.50	-6.80		-3.88	-0.19	0.00	-4.19	-9.61		15.25	15.54	16.60	20.00															

SCAVI E BONIFICHE	
SCOTICO	11.12 m
BONIFICA	6.68 mq

RILEVATI	
RILEVATO	13.24 mq
TERRENO VEGETALE	6.20 m

SOVRASTRUTTURA STRADALE	
STRATO DI USURA	6.50 m
STRATO DI BINDER	6.50 m
STRATO DI BASE	6.50 m
STRATO DI FONDAZIONE	1.14 mq

SEZIONE N. : 114

Qt. prog. : 316.16

Progr. Km : 2+260.000

Scala 1:200

Qt. rif. 304.000

Quote Progetto Pavim.						314.51		316.08	316.05	316.09			316.16			316.23	316.24	316.24		314.93											
Dist. Parz. Progetto Pavim.							2.36	0.50	0.50		2.75		2.75		0.50	0.50		1.97													
Dist. Progetto Pavim.																															
Quote Progetto Sottof.							314.52		315.77	315.77			315.85			315.93	315.93		314.91		314.93										
Dist. Parz. Progetto Sottof.								0.60			3.25		3.25		0.60		1.53														
Dist. Progetto Sottof.																															
Quote Terreno	320.90		320.98		321.01	321.01		320.97	320.94	320.92			315.22			314.73						315.10		315.08							315.16
Distanze Terreno	-30.00	-27.40	-23.92	-23.60	-20.03	-19.49	-19.26	-18.14	-17.72				-8.94	-7.82	-7.04	-5.29	0.00	2.08	6.01			12.03	13.37				20.00				

SCAVI E BONIFICHE	
SCOTICO	9.98 m
BONIFICA	5.99 mq

RILEVATI	
RILEVATO	9.67 mq
TERRENO VEGETALE	4.78 m

SOVRASTRUTTURA STRADALE	
STRATO DI USURA	6.50 m
STRATO DI BINDER	6.50 m
STRATO DI BASE	6.50 m
STRATO DI FONDAZIONE	1.14 mq

SEZIONE N. : 115
 Qt. prog. : 316.42
 Progr. Km : 2+280.000

Scala 1:200

Qt. rif. 305.000

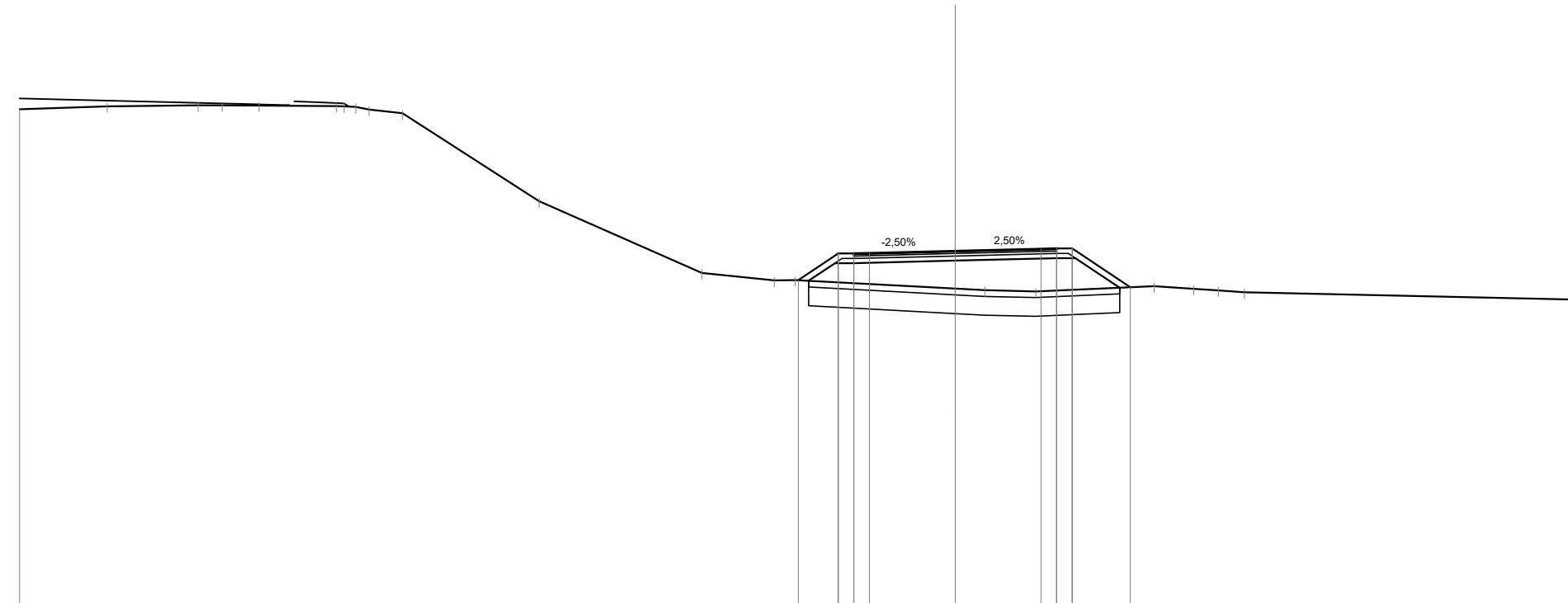

Quote Progetto Pavim.								315.48	316.33	316.30	316.35		316.42	316.48	316.50	316.50	315.25							
Dist. Parz. Progetto Pavim.								1.28	0.50	0.50			2.75	2.75	0.50	0.50	1.86							
Dist. Progetto Pavim.								-5.03	-3.75	-3.25	-2.75			0.00	-2.75	-3.25	-3.75	-5.61						
Quote Progetto Sottof.								315.46	316.02	316.02			316.11	316.19	316.19	316.19	315.24							
Dist. Parz. Progetto Sottof.								0.84	0.60		3.25		3.25	0.60	1.42									
Dist. Progetto Sottof.								-4.70	-3.85	-3.25			0.00	-3.25	-3.85	-5.28								
Quote Terreno	320.96	321.06	321.09	321.09	321.08	321.06	321.04	320.95	320.83	318.01	315.72	315.47	315.49	315.21	315.16	315.12	315.29	315.21	315.16	315.09	314.86			
Distanze Terreno	-30.00	-27.19	-24.27	-23.50	-22.32	-19.84	-19.22	-18.80	-17.72	-13.34	-8.12	-5.80	-5.13	0.00	0.96	2.58	6.37	7.65	8.43	9.27	20.00			

SCAVI E BONIFICHE	
SCOTICO	8.20 m
BONIFICA	4.93 mq

RILEVATI	
RILEVATO	1.55 mq
TERRENO VEGETALE	2.03 m

SOVRASTRUTTURA STRADALE	
STRATO DI USURA	6.50 m
STRATO DI BINDER	6.50 m
STRATO DI BASE	6.50 m
STRATO DI FONDAZIONE	1.14 mq

SEZIONE N. : 116
 Qt. prog. : 317.35
 Progr. Km : 2+300.000

Scala 1:200

Qt. rif. 306.000

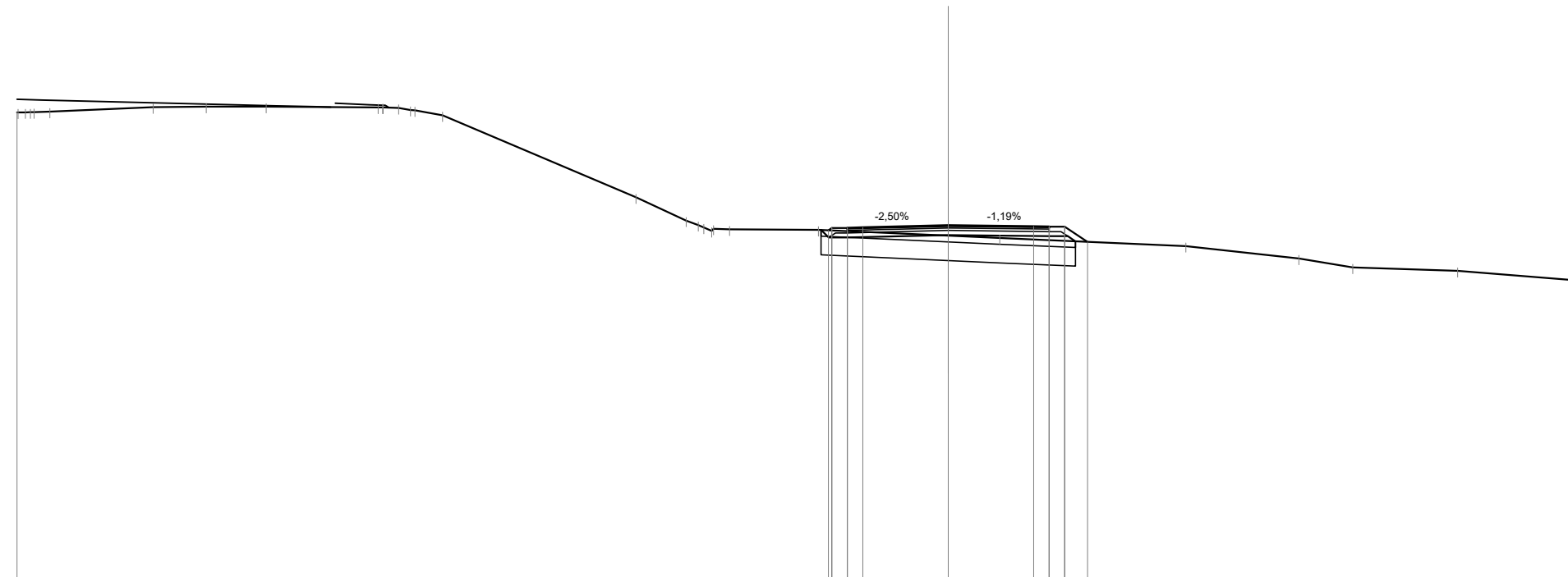

Quote Progetto Pavim.									317.20	317.27	317.29		317.35		317.32	317.32	317.32	316.82	
Dist. Parz. Progetto Pavim.									0.50	0.50	2.75		2.75		0.50	0.50	0.74		
Dist. Progetto Pavim.									-3.86	-3.75	-3.25		-2.75		-2.75	-3.25	-3.75	-4.49	
Quote Progetto Sottof.									317.21	316.96	316.96		317.04		317.01	317.01	316.84		
Dist. Parz. Progetto Sottof.									0.24	0.60	3.25		3.25		0.60				
Dist. Progetto Sottof.									-4.10	-3.85	-3.25		-0.00		-3.25	-3.85	-4.10		
Quote Terreno	321.00	321.00	321.02						321.16	321.14	321.06	320.90		318.26		317.29	317.23		
Distanze Terreno	-30.00	-29.72	-28.94						-18.37	-17.70	-17.17	-16.29		-10.06		-8.44	-7.87		

SCAVI E BONIFICHE	
SCOTICO	8.35 m
BONIFICA	5.01 mq

RILEVATI	
RILEVATO	2.96 mq
TERRENO VEGETALE	2.63 m

SOVRASTRUTTURA STRADALE	
STRATO DI USURA	6.50 m
STRATO DI BINDER	6.50 m
STRATO DI BASE	6.50 m
STRATO DI FONDAZIONE	1.14 mq

SEZIONE N. : 117
 Qt. prog. : 318.45
 Progr. Km : 2+320.000

Scala 1:200

Qt. rif. 306.000

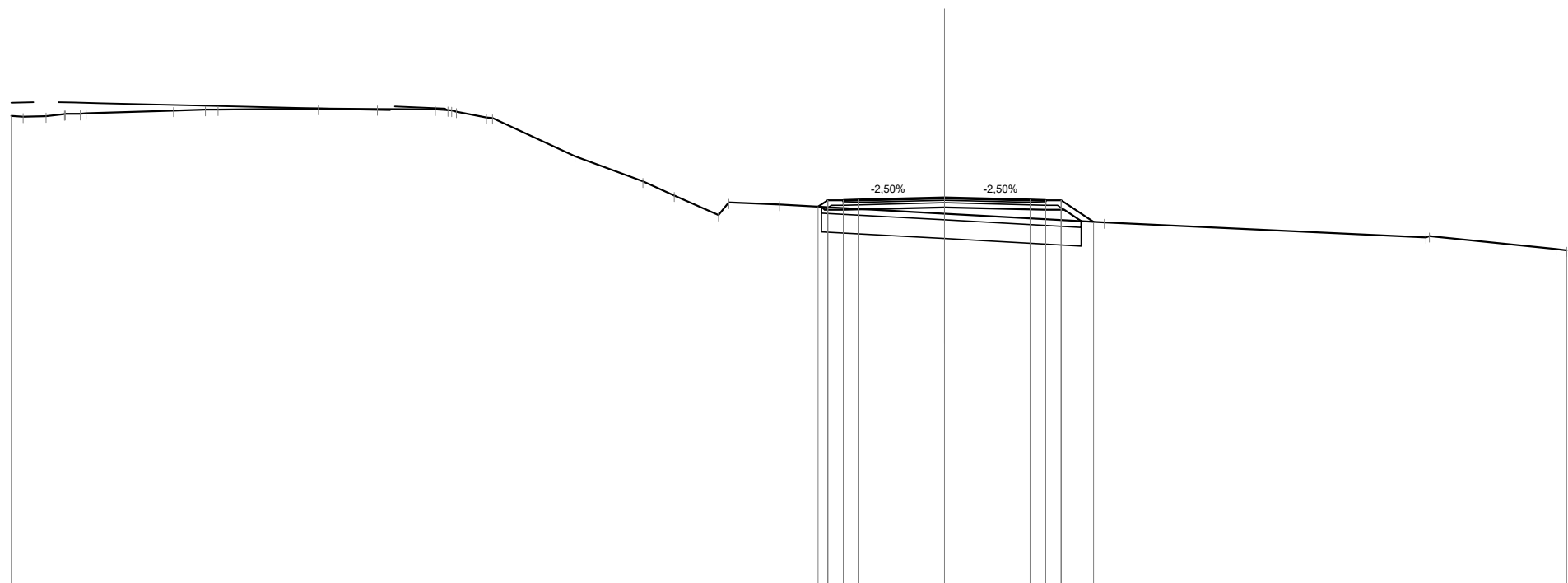

Quote Progetto Pavim.				318.17	318.37	318.34	318.39				318.45	318.39	318.37	317.68														
Dist. Parz. Progetto Pavim.				0.50	0.50	2.75	2.75	0.50	0.50	1.04																		
Dist. Progetto Pavim.				4.06	3.75	3.25	2.75	0.00	2.75	3.25	3.75	4.79																
Quote Progetto Sottof.				318.16	318.06	318.14	318.14	318.06	318.06	317.70																		
Dist. Parz. Progetto Sottof.				0.10	0.60	3.25	3.25	0.60	0.54																			
Dist. Progetto Sottof.				3.95	3.25	0.00	3.25	4.40																				
Quote Terreno	321.08	321.06	321.07	321.14	321.15	321.17	321.25	321.28	321.29	321.30	321.29	321.26	321.22	321.03	321.01	319.79	318.98	318.53	317.90	318.30	318.23	317.94	317.66	317.18	317.22	316.81	316.76	
Distanze Terreno	-30.00	-29.61	-28.88	-28.28	-27.78	-27.59	-24.78	-23.76	-23.35	-20.12	-18.23	-16.37	-15.84	-15.69	-14.72	-14.53	-11.88	-9.70	-8.69	-7.26	-6.93	-5.31	0.00	-5.14	15.48	15.59	19.66	20.00

SCAVI E BONIFICHE	
SCOTICO	8.37 m
BONIFICA	5.03 mq

RILEVATI	
RILEVATO	3.13 mq
TERRENO VEGETALE	2.80 m

SOVRASTRUTTURA STRADALE	
STRATO DI USURA	6.61 m
STRATO DI BINDER	6.61 m
STRATO DI BASE	6.61 m
STRATO DI FONDAZIONE	1.15 mq

SEZIONE N. : 118
 Qt. prog. : 319.50
 Progr. Km : 2+340.000

Scala 1:200

Qt. rif. 307.000

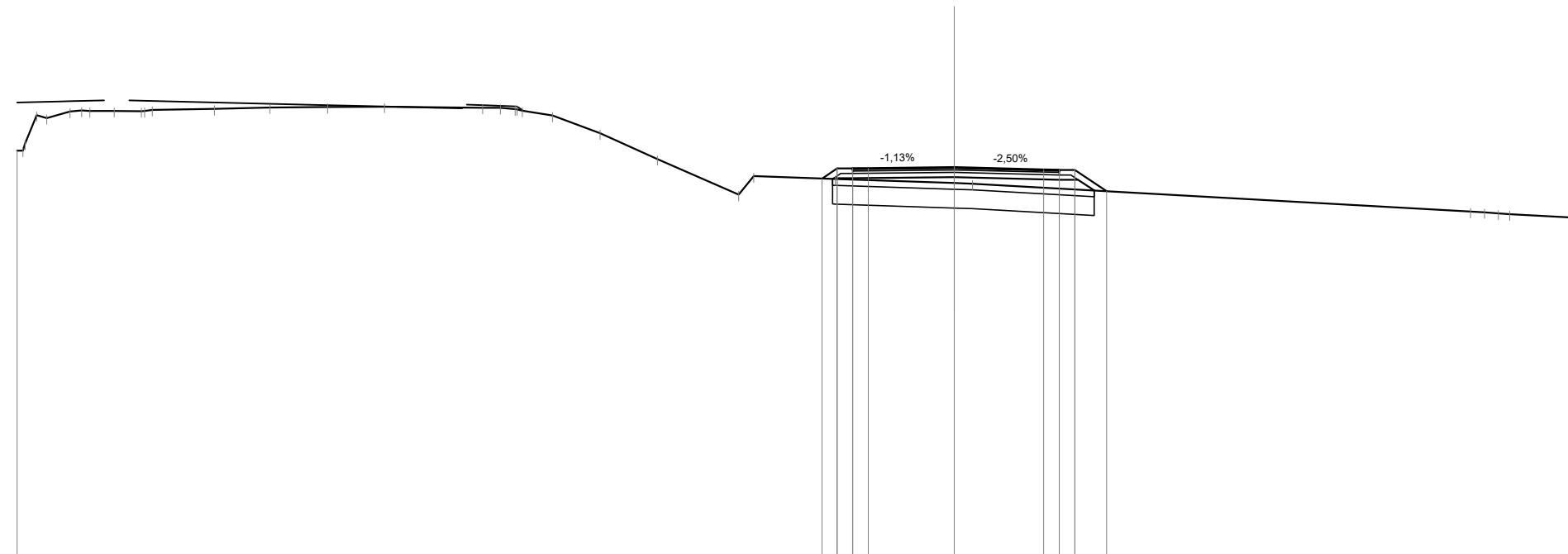

Quote Progetto Pavim.											319.14	319.46	319.49	319.47		319.50		319.43	319.41	319.41	318.74								
Dist. Parz. Progetto Pavim.											0.48	0.50	0.50	2.75		2.86		0.50	0.50	1.02									
Dist. Progetto Pavim.											-4.23	-3.75	-3.25	-2.75		0.00		-2.86	-3.36	-3.86	-4.87								
Quote Progetto Sottof.											319.13	319.15	319.15	319.19	319.19	319.19	319.19	319.10	319.10	318.76	318.76								
Dist. Parz. Progetto Sottof.											0.04	0.60	3.25	3.36	3.36	3.36	3.36	0.60	0.52	4.48	4.87								
Dist. Progetto Sottof.											-3.89	-3.25	-3.25	-3.25	-3.25	-3.25	-3.25	-3.36	-3.96	-4.48	-4.87								
Quote Terreno	320.03	320.26	321.07	321.28	321.30	321.30	321.34	321.37	321.42	321.43	321.44	321.40	321.40	321.36	321.31	321.15	320.59	319.76	318.62	319.22	319.12	319.00	318.98	318.08	318.06	318.02	318.00	317.88	
Distanze Terreno	-30.00	-29.74	-29.05	-28.30	-27.67	-26.89	-26.02	-25.67	-23.68	-21.90	-20.06	-18.24	-15.10	-14.53	-14.05	-13.83	-12.86	-11.34	-9.50	-6.90	-6.42	-3.81	-0.00	-0.58	16.53	16.98	17.42	17.76	20.00

SCAVI E BONIFICHE	
SCOTICO	8.30 m
BONIFICA	4.98 mq

RILEVATI	
RILEVATO	0.57 mq
TERRENO VEGETALE	1.78 m

SOVRASTRUTTURA STRADALE	
STRATO DI USURA	6.80 m
STRATO DI BINDER	6.80 m
STRATO DI BASE	6.80 m
STRATO DI FONDAZIONE	1.18 mq

SEZIONE N. : 120
 Qt. prog. : 319.67
 Progr. Km : 2+380.000

Scala 1:200

Qt. rif. 307.000

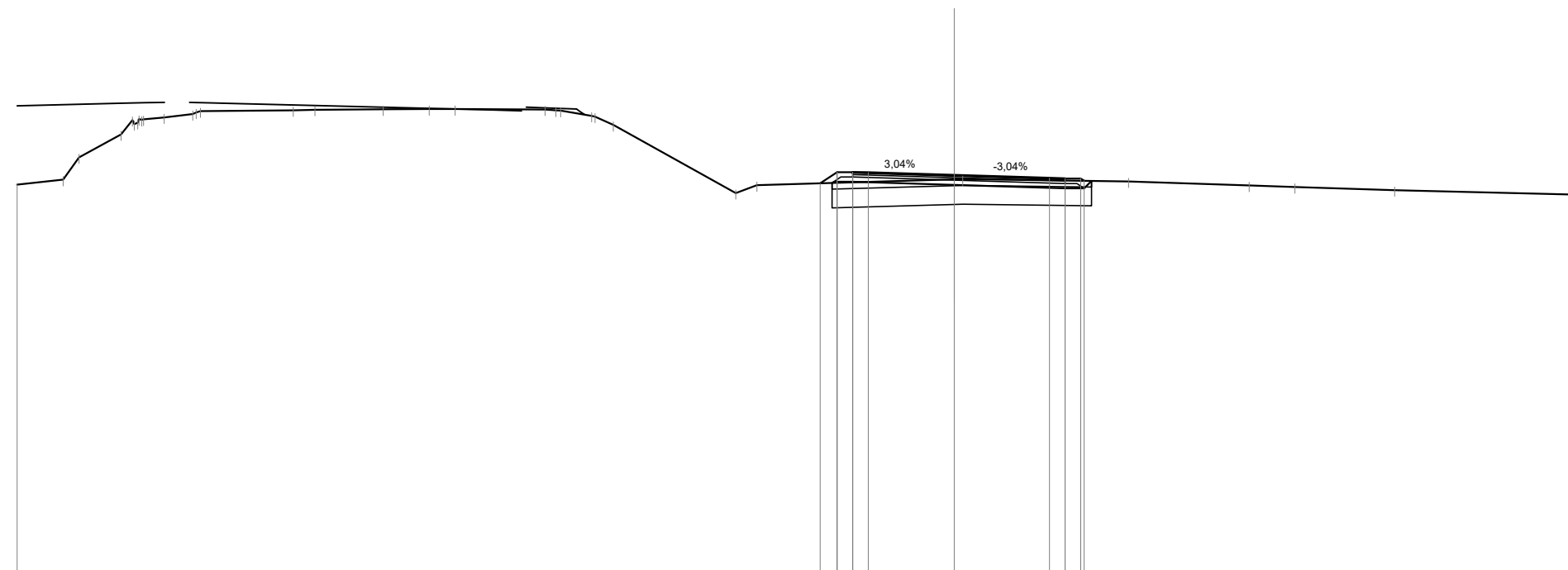

Quote Progetto Pavim.										319.41	319.76	319.73	319.75		319.67		319.57	319.56	319.56	319.49							
Dist. Parz. Progetto Pavim.										0.54	0.50	0.50	0.50	2.75	3.05		0.50	0.50	0.50								
Dist. Progetto Pavim.										-4.29	-3.75	-3.25	-2.75		0.00		3.05	3.55	4.05	4.16							
Quote Progetto Sottof.										319.42	319.45	319.45	319.45		319.36		319.25	319.25	319.25	319.48							
Dist. Parz. Progetto Sottof.										0.06	0.60	0.60	3.25		3.55		0.60	4.15	4.39								
Dist. Progetto Sottof.										-3.91	-3.25				0.00		-3.55	-4.15	-4.39								
Quote Terreno	319.37	319.52	320.24	320.97	321.34	321.45	321.51	321.62	321.71	321.74	321.76	321.77	321.78	321.78	321.77	321.73	321.57	321.27	319.10	319.35	319.53	319.54	319.47	319.34	319.28	319.19	319.04
Distanze Terreno	-30.00	-28.52	-28.02	-26.67	-26.14	-25.95	-25.29	-24.38	-24.13	-21.16	-20.46	-18.28	-16.81	-15.97	-13.10	-12.60	-11.61	-10.91	-6.99	-6.31	0.00	0.27	-5.58	-9.44	-10.90	-14.10	-20.00

SCAVI E BONIFICHE	
SCOTICO	8.72 m
BONIFICA	5.24 mq

RILEVATI	
RILEVATO	2.09 mq
TERRENO VEGETALE	2.35 m

SOVRASTRUTTURA STRADALE	
STRATO DI USURA	6.75 m
STRATO DI BINDER	6.75 m
STRATO DI BASE	6.75 m
STRATO DI FONDAZIONE	1.17 mq

SEZIONE N. : 121
 Qt. prog. : 318.66
 Progr. Km : 2+400.000

Scala 1:200

Qt. rif. 307.000

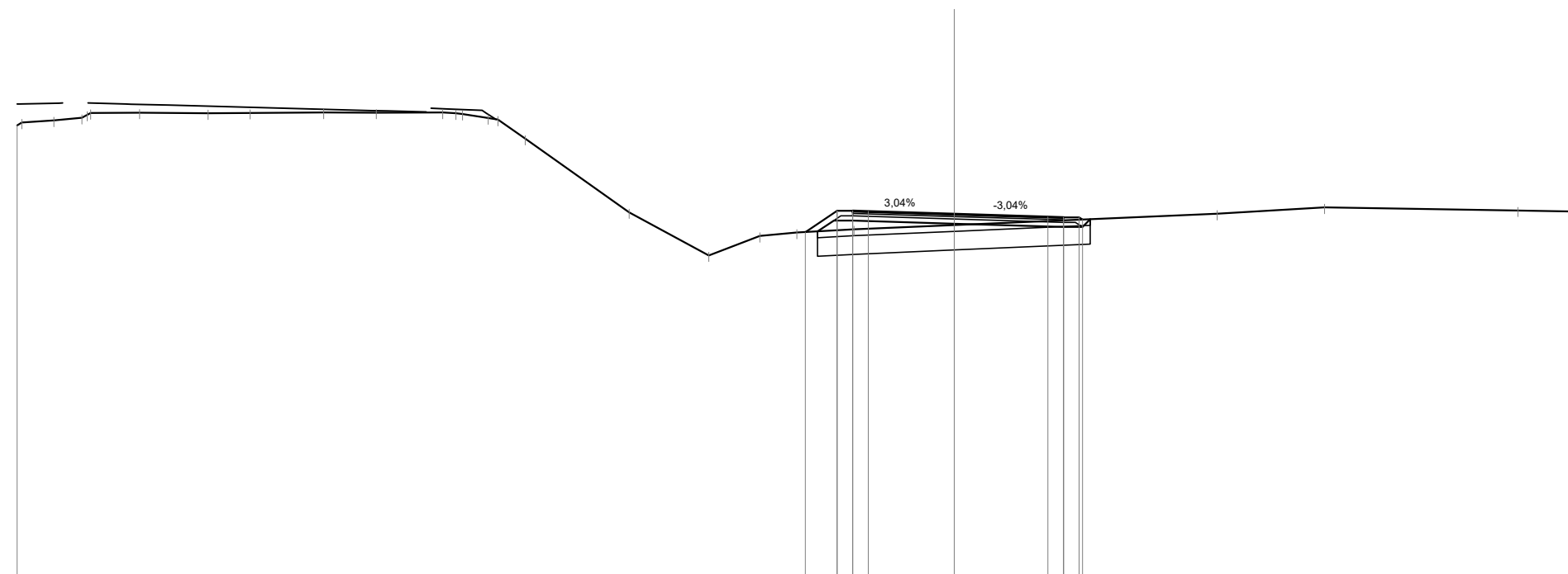

Quote Progetto Pavim.	318.08 318.76 318.73 318.74	318.66	318.57 318.55 318.55 318.48	
Dist. Parz. Progetto Pavim.	1.02 0.50 0.50	2.75	3.00 0.50 0.50	
Dist. Progetto Pavim.	-4.77 -3.75 -3.25 -2.75	0.00	3.00 3.50 4.00 4.10	
Quote Progetto Sottof.	318.10 318.45 318.45	318.35	318.24 318.24 318.49	
Dist. Parz. Progetto Sottof.	0.52 0.60 3.25	3.50	0.60 4.10 4.35	
Dist. Progetto Sottof.	-4.37 -3.85 -3.25	0.00	-3.50 -4.10 -4.35	
Quote Terreno	321.49 321.59 321.66 321.74 321.89 321.91 321.88 321.90 321.91 321.91 321.91 321.86 321.73 321.68 321.07	318.71 317.33 317.96 318.06 318.17	318.31	318.67 318.87 318.77 318.74
Distanze Terreno	-30.00 -29.84 -28.82 -27.92 -27.65 -26.07 -23.88 -22.53 -20.18 -18.50 -16.38 -15.74 -14.92 -14.61 -13.73 -10.41 -7.86 -6.22 -5.04 -3.21	-0.00	-8.41 -11.86 -18.04 -20.00	

SCAVI E BONIFICHE	
SCOTICO	9.67 m
BONIFICA	5.80 mq

RILEVATI	
RILEVATO	8.55 mq
TERRENO VEGETALE	4.40 m

SOVRASTRUTTURA STRADALE	
STRATO DI USURA	6.51 m
STRATO DI BINDER	6.51 m
STRATO DI BASE	6.51 m
STRATO DI FONDAZIONE	1.14 mq

SEZIONE N. : 122

Qt. prog. : 317.10

Progr. Km : 2+420.000

Scala 1:200

Qt. rif. 306.000

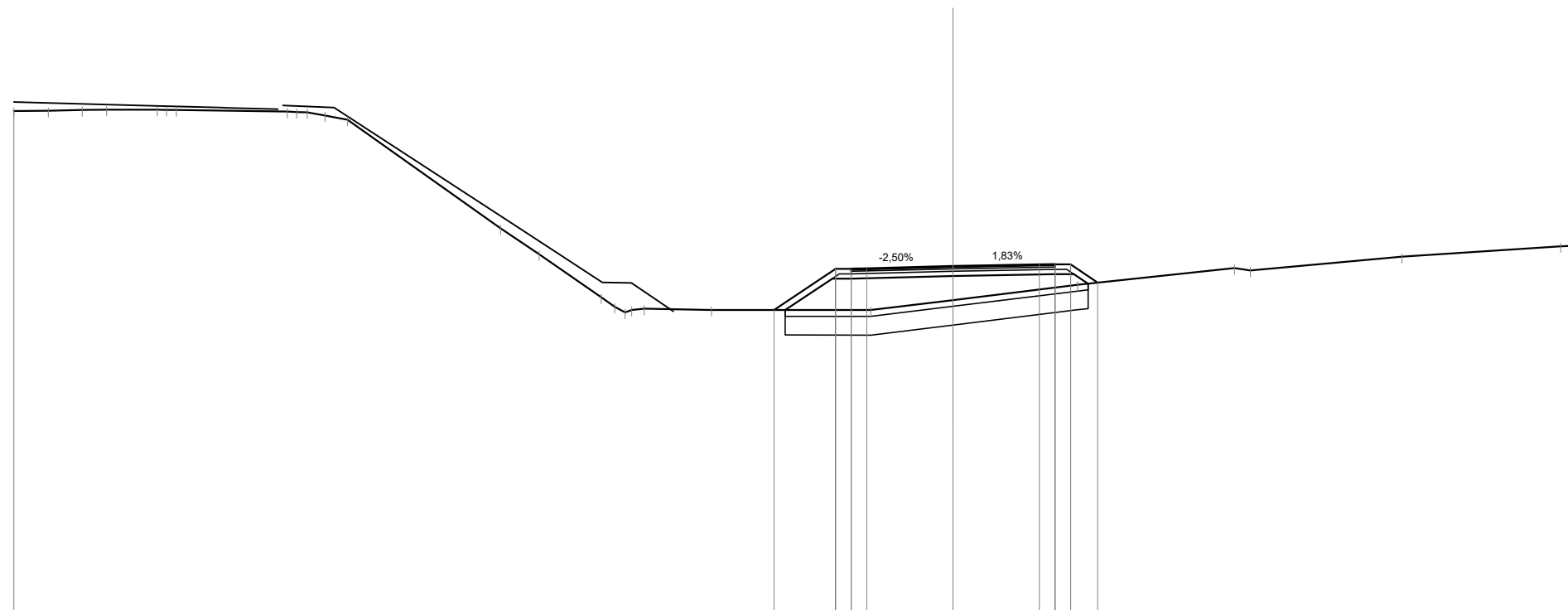

Quote Progetto Pavim.										315.70	317.02	316.99	317.03		317.10		317.15	317.16	316.58					
Dist. Parz. Progetto Pavim.										1.97	0.50	0.50		2.75		2.76	0.50	0.50	0.87					
Dist. Progetto Pavim.										-5.72	-3.75	-3.25	-2.75		0.00		-2.76	-3.26	-3.76	-4.63				
Quote Progetto Sottof.										315.70	316.71	316.71			316.79		316.85	316.85	316.54					
Dist. Parz. Progetto Sottof.										1.50	0.60		3.25		3.26		0.60	0.45						
Dist. Progetto Sottof.										-5.36	-3.85	-3.25			0.00		-3.26	-3.86	-4.32					
Quote Terreno	322.05	322.06	322.09	322.09	322.09	322.03	322.01	321.91	321.78	318.31	317.49	316.11	315.63	315.75	315.71	316.02	316.51	317.04	316.97	317.40	317.74	317.77		
Distanze Terreno	-30.00	-28.90	-27.81	-27.03	-25.42	-24.80	-21.26	-20.62	-20.05	-19.34	-14.45	-13.22	-11.24	-10.47	-9.86	-7.71	-2.62	0.00	-3.98	-8.99	-9.50	-14.34	-19.41	-20.00

SCAVI E BONIFICHE	
SCOTICO	12.42 m
BONIFICA	7.46 mq

RILEVATI	
RILEVATO	19.80 mq
TERRENO VEGETALE	7.72 m

SOVRASTRUTTURA STRADALE	
STRATO DI USURA	6.50 m
STRATO DI BINDER	6.50 m
STRATO DI BASE	6.50 m
STRATO DI FONDAZIONE	1.14 mq

SEZIONE N. : 123
 Qt. prog. : 316.25
 Progr. Km : 2+440.000

Scala 1:200

Qt. rif. 305.000

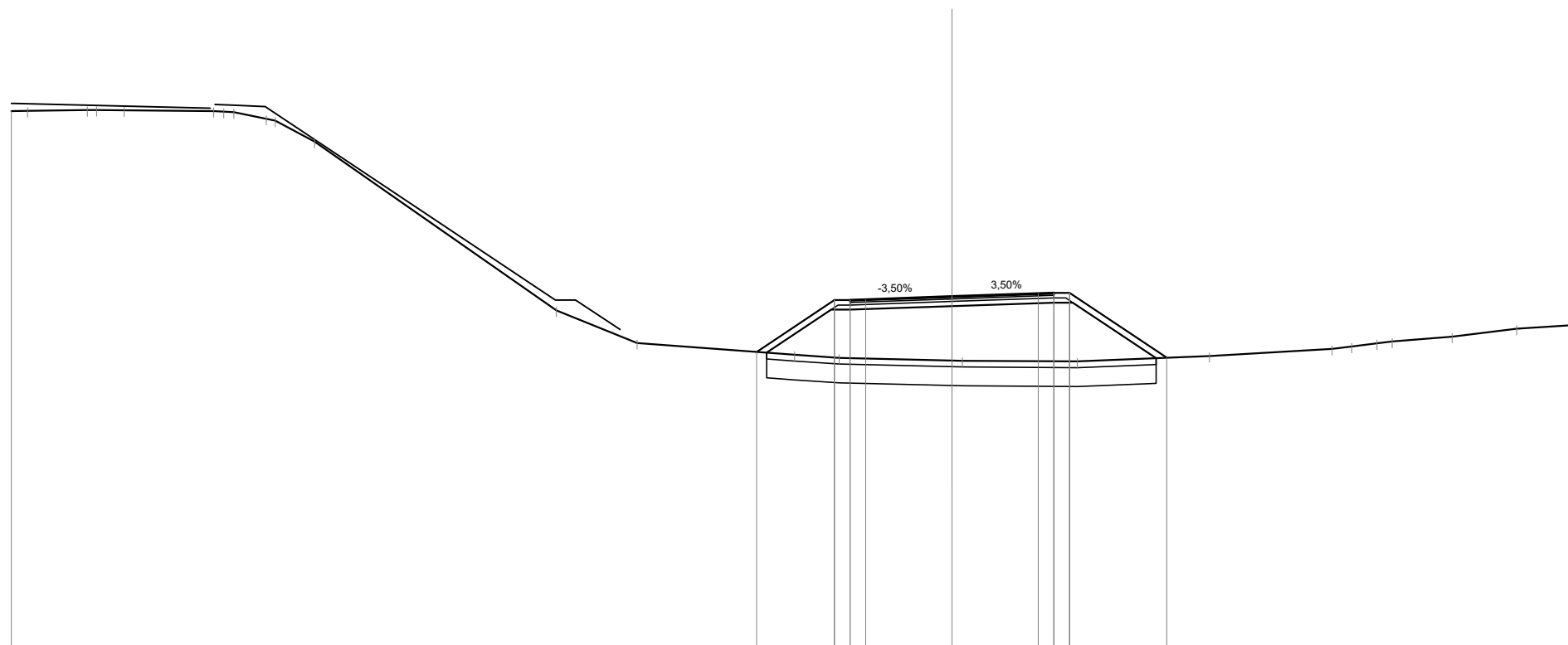

Quote Progetto Pavim.	314.48		316.14	316.11	316.15	316.25	316.35	316.36	316.36	314.29															
Dist. Parz. Progetto Pavim.			2.48	0.50	0.50	2.75	2.75	0.50	0.50	3.10															
Dist. Progetto Pavim.			-6.23	-3.75	-3.25	-2.75	0.00	-2.75	-3.25	-3.75	6.85														
Quote Progetto Sottof.	314.46		315.83	315.83		315.94	316.05	316.05	316.05	314.28															
Dist. Parz. Progetto Sottof.	2.06		0.60		3.25	3.25	0.60	2.66																	
Dist. Progetto Sottof.	-5.91		-3.85	-3.25	0.00	3.25	-3.25	-3.85	6.51																
Quote Terreno	322.17	322.17		314.39	314.29	314.21	314.20	314.18		314.35	314.58	314.65	314.75	314.81	314.97	315.22	315.35								
Distanze Terreno	-30.00	-29.48	-27.58	-27.28	-26.40	-23.55	-22.90	-21.87	-21.56	-20.33	-12.61	-10.04	-5.02	-3.59	0.00	0.33	4.00	8.21	12.12	12.75	13.56	14.03	15.95	18.01	20.00

SCAVI E BONIFICHE	
SCOTICO	11.09 m
BONIFICA	6.65 mq

RILEVATI	
RILEVATO	12.39 mq
TERRENO VEGETALE	6.05 m

SOVRASTRUTTURA STRADALE	
STRATO DI USURA	6.62 m
STRATO DI BINDER	6.62 m
STRATO DI BASE	6.62 m
STRATO DI FONDAZIONE	1.16 mq

SEZIONE N. : 124

Qt. prog. : 316.74

Progr. Km : 2+460.000

Scala 1:200

Qt. rif. 305.000

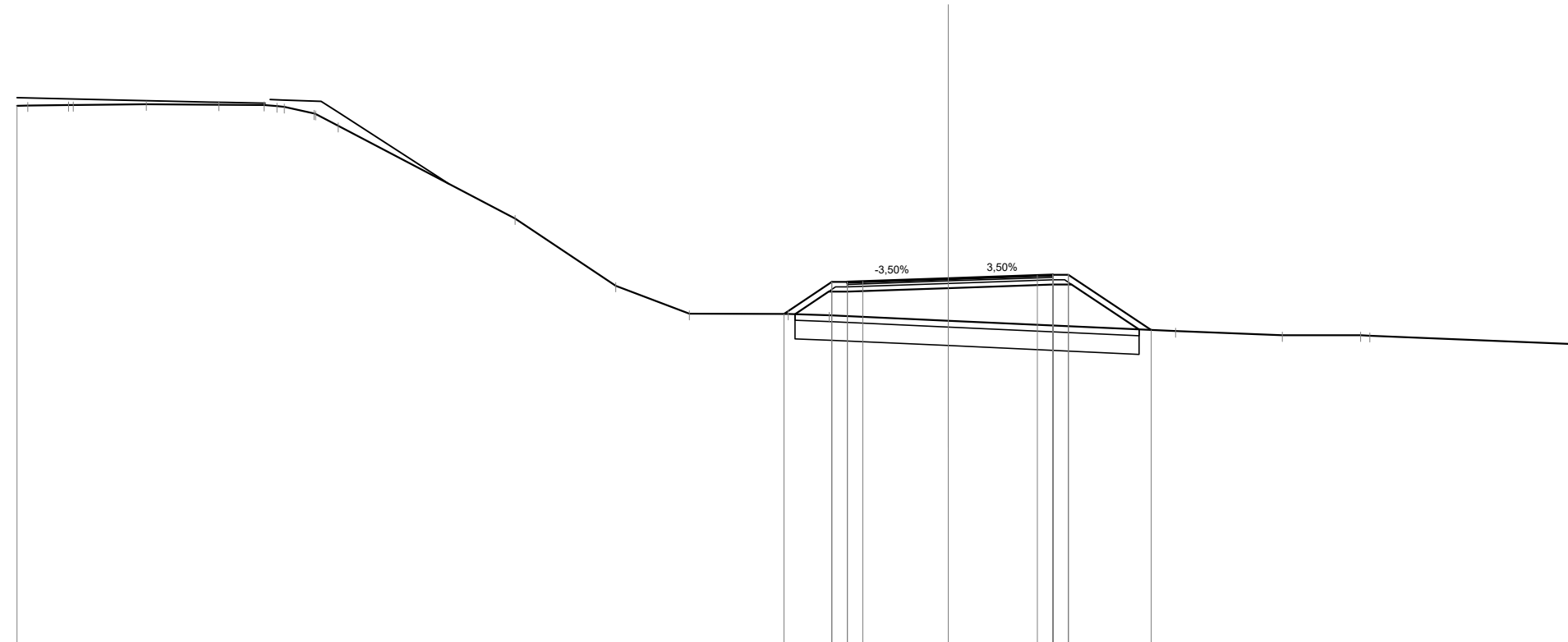

Quote Progetto Pavim.												315.60	316.62	316.59	316.64	316.74	316.84	316.85	316.85	315.08			
Dist. Parz. Progetto Pavim.												1.54	0.50	0.50	2.75	2.87	0.50	0.50	2.67				
Dist. Progetto Pavim.												-5.29	-3.75	-3.25	-2.75	0.00	-2.87	-3.37	-3.87	-6.54			
Quote Progetto Sottof.												315.59	316.31	316.31	316.43	316.43	316.54	316.54	315.09				
Dist. Parz. Progetto Sottof.												1.08	0.60	3.25	3.37	0.60	2.17						
Dist. Progetto Sottof.												-4.94	-3.85	-3.25	0.00	-3.37	-3.97	-6.15					
Quote Terreno	322.30	322.31	322.32	322.32	322.35	322.34	322.33	322.26	322.05	322.04	321.65	318.67	316.50	315.60	315.60	315.55	315.55	315.37	315.04	314.91	314.91	314.89	314.63
Distanze Terreno	-30.00	-29.65	-28.33	-28.19	-25.83	-23.49	-22.04	-21.39	-20.43	-20.38	-19.65	-13.95	-10.71	-8.34	-5.16	-3.83	0.00	7.32	10.76	13.29	13.58	20.00	

SCAVI E BONIFICHE	
SCOTICO	8.66 m
BONIFICA	5.19 mq

RILEVATI	
RILEVATO	1.43 mq
TERRENO VEGETALE	1.86 m

SOVRASTRUTTURA STRADALE	
STRATO DI USURA	6.51 m
STRATO DI BINDER	6.51 m
STRATO DI BASE	6.51 m
STRATO DI FONDAZIONE	1.15 mq

SEZIONE N. : 127
 Qt. prog. : 320.69
 Progr. Km : 2+520.000

Scala 1:200

Qt. rif. 308.000

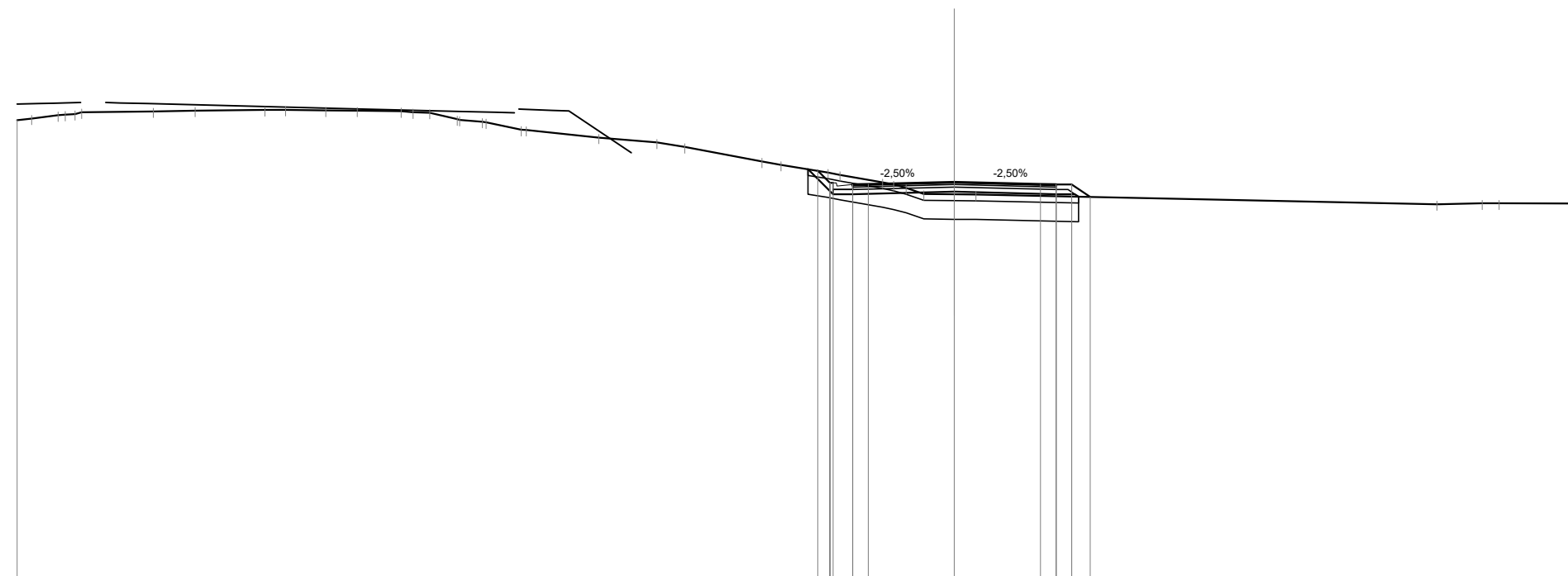

Quote Progetto Pavim.										321.04	320.66	320.61	320.62			320.69		320.62	320.61	320.21																
Dist. Parz. Progetto Pavim.										0.39	0.63	0.50	2.75			2.76		0.50	0.50	0.59																
Dist. Progetto Pavim.										-4.37	-3.98	-3.88	-3.25			-0.00		-2.76	-3.26	-3.76	-4.35															
Quote Progetto Sottof.										321.10	320.30	320.30			320.38	0.00		320.30	320.30	320.22																
Dist. Parz. Progetto Sottof.										0.80	0.63	3.25			3.26			0.60																		
Dist. Progetto Sottof.										-4.68	-3.88	-3.25			-0.00			-3.26	-3.86	-3.98																
Quote Terreno	322.66	322.72	322.82	322.86	322.92	322.95	322.97	322.99	323.00	322.98	322.97	322.95	322.91	322.70	322.68	322.60	322.36	322.35	322.11	321.95	321.81	321.34	321.24	320.99	320.91	320.68	320.50	320.30	320.29	320.29			319.98	320.00	320.00	320.00
Distanze Terreno	-30.00	-29.53	-28.69	-28.14	-27.93	-25.63	-24.30	-22.07	-21.40	-20.11	-19.11	-17.70	-16.79	-15.91	-15.83	-14.99	-13.86	-13.70	-11.38	-9.51	-8.62	-6.15	-5.54	-4.04	-3.66	-2.30	-1.54	-0.97	-0.00	0.69			15.45	16.90	17.44	20.00

SCAVI E BONIFICHE	
SCOTICO	8.74 m
BONIFICA	5.24 mq

RILEVATI	
RILEVATO	1.67 mq
TERRENO VEGETALE	2.05 m

SOVRASTRUTTURA STRADALE	
STRATO DI USURA	7.47 m
STRATO DI BINDER	7.47 m
STRATO DI BASE	7.47 m
STRATO DI FONDAZIONE	1.28 mq

SEZIONE N. : 129
 Qt. prog. : 322.09
 Progr. Km : 2+560.000

Scala 1:200

Qt. rif. 309.000

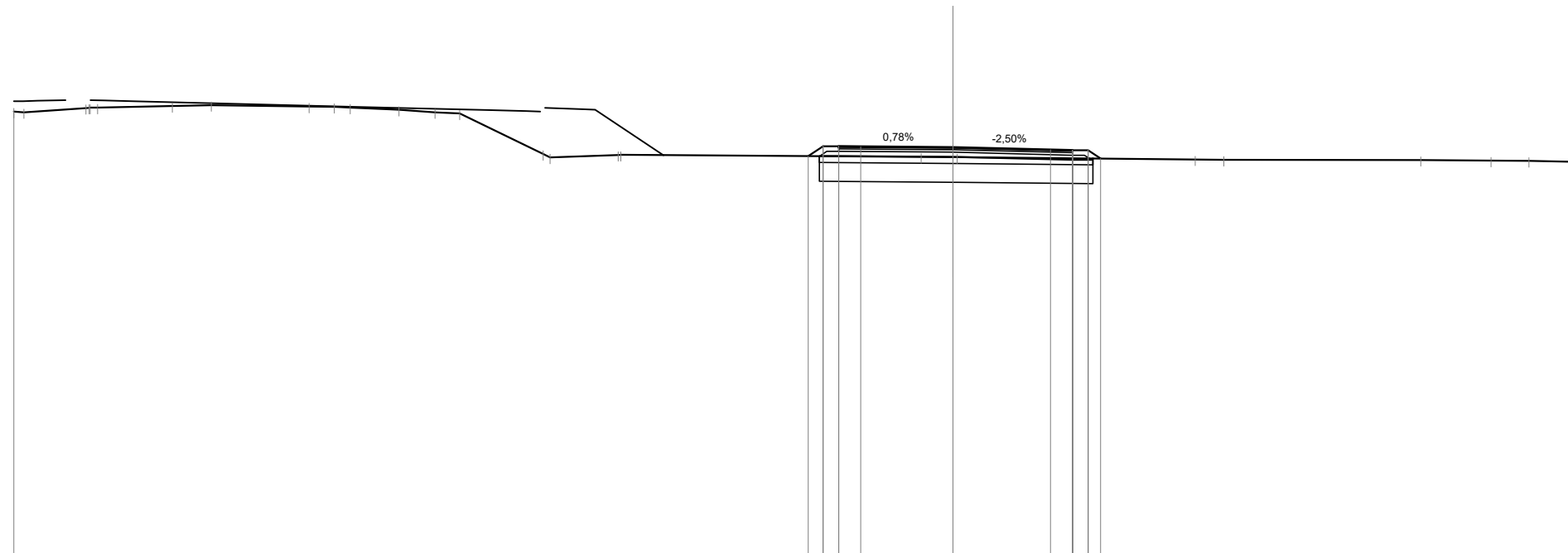

Quote Progetto Pavim.												321.81	322.12	322.09	322.12	322.09	322.02	321.97	322.00	321.73					
Dist. Parz. Progetto Pavim.												0.47	0.50	0.70	2.95	3.12	0.70	0.50	0.40						
Dist. Progetto Pavim.												-4.62	-4.15	-3.65	-2.95	0.00	-3.12	-3.82	-4.32	-4.72					
Quote Progetto Sottof.												321.81	321.81			321.78	321.69	321.69	321.73						
Dist. Parz. Progetto Sottof.												0.01	0.60		3.65		3.82	0.60							
Dist. Progetto Sottof.												-4.26	-3.65			0.00	-3.82	-4.42	-4.47						
Quote Terreno	323.23	323.21										321.88	321.77			321.78	321.78	321.77		321.85					
Distanze Terreno	-30.00	-29.68	-27.69	-27.32	-24.94	-23.69	-23.44	-20.57	-19.76	-19.25	-17.69	-16.55	-15.76	-13.09	-12.87	-10.70	-10.61			-7.73	-8.65	-14.95	-17.19	-18.39	-20.00

SCAVI E BONIFICHE	
SCOTICO	9.85 m
BONIFICA	5.91 mq

RILEVATI	
RILEVATO	2.29 mq
TERRENO VEGETALE	2.26 m

SOVRASTRUTTURA STRADALE	
STRATO DI USURA	8.38 m
STRATO DI BINDER	8.38 m
STRATO DI BASE	8.38 m
STRATO DI FONDAZIONE	1.42 mq

SEZIONE N. : 130
 Qt. prog. : 322.63
 Progr. Km : 2+580.000

Scala 1:200

Qt. rif. 310.000

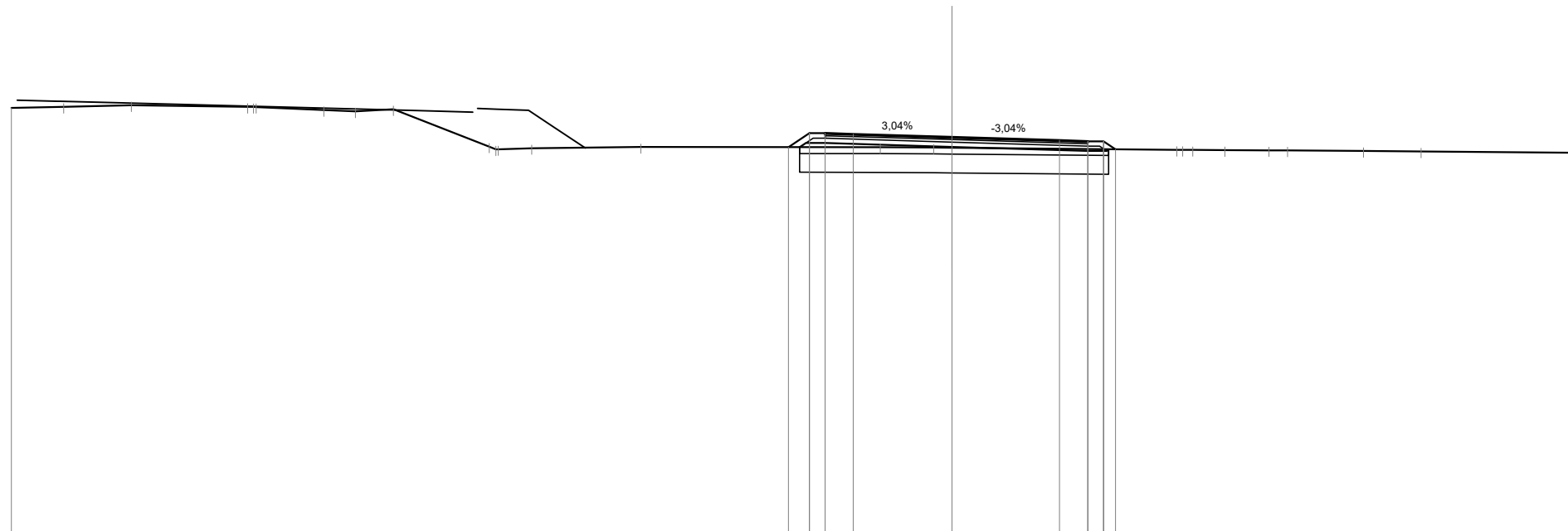

Quote Progetto Pavim.								322.31	322.76	322.73		322.63		322.53	322.50	322.50	322.24						
Dist. Parz. Progetto Pavim.								0.67	0.50	0.90		3.15		3.43	0.90	0.50	0.39						
Dist. Progetto Pavim.								-5.22	-4.55	-4.05		-3.15		0.00	-3.43	-4.33	-4.83	-5.22					
Quote Progetto Sottof.								322.31	322.45			322.32		322.19	322.19	322.25							
Dist. Parz. Progetto Sottof.								0.20	0.60			4.05		4.33	0.60								
Dist. Progetto Sottof.								-4.86	-4.05			0.00		-4.33	-4.94	-4.99							
Quote Terreno	323.57	323.60	323.65	323.60	323.59	323.50	323.45	323.52	322.33	322.25	322.28	322.32	322.31	322.30	322.29	322.23	322.22	322.22	322.21	322.21	322.19	322.18	322.13
Distanze Terreno	-30.00	-28.33	-26.17	-22.46	-22.19	-20.04	-19.03	-17.81	-14.76	-14.47	-13.40	-9.92	-2.28	-0.58	0.00	7.17	7.68	8.70	10.11	10.70	13.12	14.96	20.00

SCAVI E BONIFICHE	
SCOTICO	11.98 m
BONIFICA	7.18 mq

RILEVATI	
RILEVATO	3.15 mq
TERRENO VEGETALE	3.92 m

SOVRASTRUTTURA STRADALE	
STRATO DI USURA	8.80 m
STRATO DI BINDER	8.80 m
STRATO DI BASE	8.80 m
STRATO DI FONDAZIONE	1.74 mq

SEZIONE N. : 131
 Qt. prog. : 323.12
 Progr. Km : 2+600.000

Scala 1:200

Qt. rif. 310.000

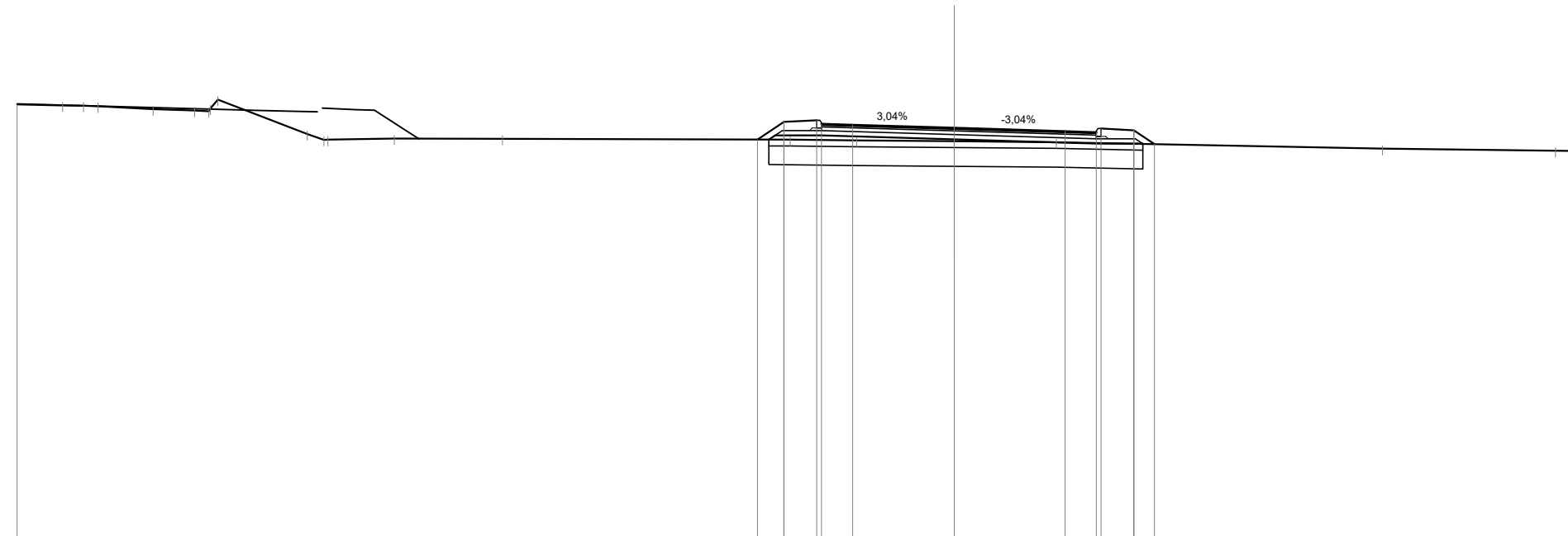

Quote Progetto Pavim.							322.75	323.32	323.37	323.25	323.22		323.12		323.01	322.98	323.10	323.05	322.61
Dist. Parz. Progetto Pavim.							0.85	1.05	1.00		3.25		3.55		1.00	1.05	0.66		
Dist. Progetto Pavim.							-6.30	-5.45	-4.40	-4.25	-3.25		0.00		-3.55	-4.55	-4.70	-5.75	-6.41
Quote Progetto Sottof.							322.75	322.89	322.89				322.76		322.62	322.62	322.62		
Dist. Parz. Progetto Sottof.							0.21	1.48		4.25			4.55		1.48	0.01			
Dist. Progetto Sottof.							-5.94	-5.73	-4.25			0.00			-4.55	6.03	6.04		
Quote Terreno	323.88	323.85	323.84	323.82	323.72	323.68	323.66	324.03	322.93	322.75	322.75	322.79	322.78	322.70	322.67	322.46	322.40	322.39	
Distanze Terreno	-30.00	-28.54	-27.87	-27.41	-25.65	-24.32	-23.86	-23.57	-20.71	-20.18	-20.04	-17.92	-14.46	0.00	3.27	13.70	19.25	20.00	

SCAVI E BONIFICHE	
SCOTICO	12.62 m
BONIFICA	7.58 mq

RILEVATI	
RILEVATO	3.48 mq
TERRENO VEGETALE	4.56 m

SOVRASTRUTTURA STRADALE	
STRATO DI USURA	8.80 m
STRATO DI BINDER	8.80 m
STRATO DI BASE	8.80 m
STRATO DI FONDAZIONE	1.82 mq

SEZIONE N. : 132

Qt. prog. : 323.42

Progr. Km : 2+620.000

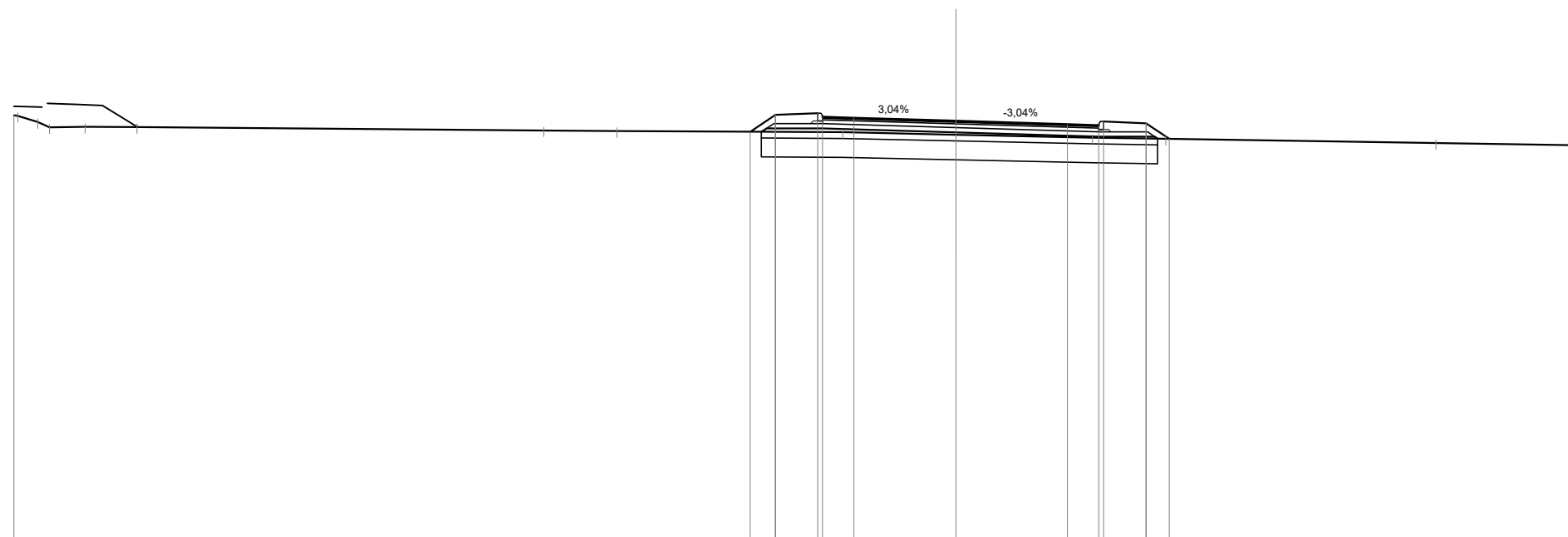

Scala 1:200

Qt. rif. 310.000

Quote Progetto Pavim.							323.08	323.61	323.67	323.55	323.52		323.42		323.31	323.28	323.40	323.35	322.85
Dist. Parz. Progetto Pavim.							0.80	1.35	1.00	3.25		3.55		1.00	1.35		0.74		
Dist. Progetto Pavim.							-6.55	-5.75	-4.40	-4.25	-3.25		-0.00		-3.55	-4.55	-4.70	-6.05	-6.79
Quote Progetto Sottof.							323.08	323.19	323.19				323.06		322.92	322.92	322.86	322.86	
Dist. Parz. Progetto Sottof.							0.17	1.78		4.25		4.55		1.78	0.00				
Dist. Progetto Sottof.							-6.20	-6.03	-4.25			-0.00		-4.55	6.33	6.42			
Quote Terreno	323.60	323.39	323.21	323.23		323.12			323.10		323.06		322.98		322.89	322.85		322.72	322.65
Distanze Terreno	-30.00	-29.24	-28.87	-27.73	-26.08	-13.12			-10.80		-3.61		0.00		-4.34	-6.68		-15.28	-19.61

SCAVI E BONIFICHE	
SCOTICO	12.48 m
BONIFICA	7.49 mq

RILEVATI	
RILEVATO	1.04 mq
TERRENO VEGETALE	3.75 m

SOVRASTRUTTURA STRADALE	
STRATO DI USURA	8.65 m
STRATO DI BINDER	8.65 m
STRATO DI BASE	8.65 m
STRATO DI FONDAZIONE	1.80 mq

SEZIONE N. : 134
 Qt. prog. : 323.71
 Progr. Km : 2+660.000

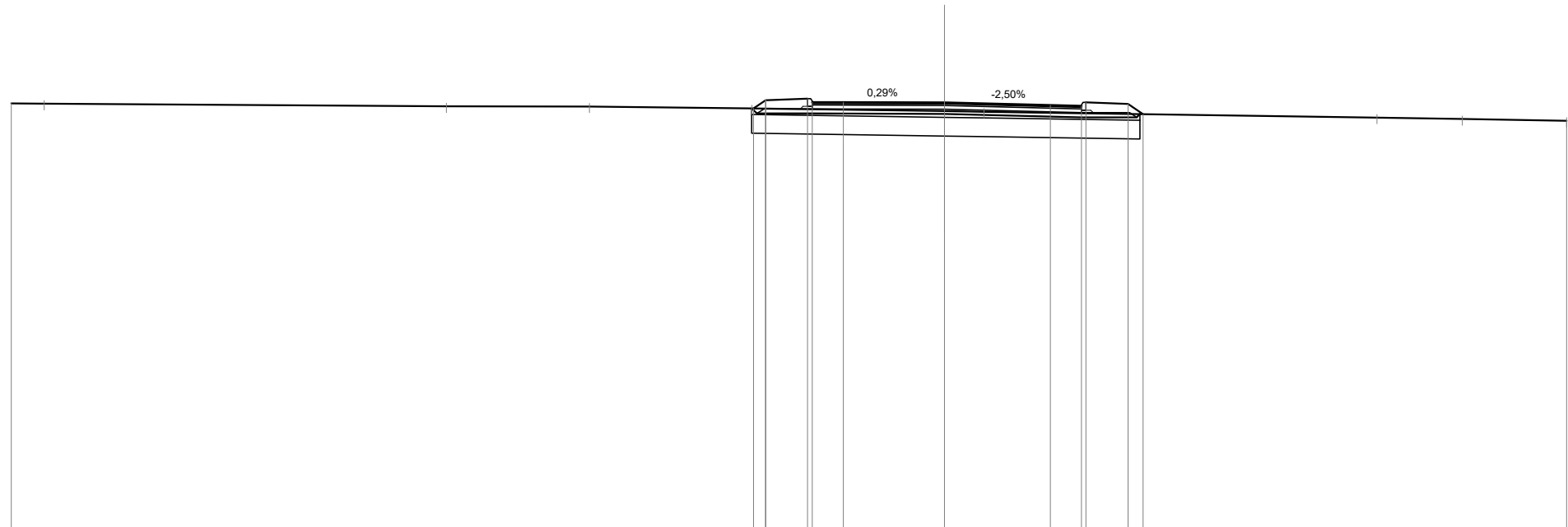

Scala 1:200

Qt. rif. 310.000

Quote Progetto Pavim.								323.52	323.78			323.62	323.60	323.72	323.66	323.34			
Dist. Parz. Progetto Pavim.								0.39	1.35	1.00	3.25	3.40	1.00	1.35	0.48				
Dist. Progetto Pavim.								-6.14	-5.75	-4.40	-4.25	-3.25	0.00	0.00	-3.40	-4.40	-4.55	-5.90	-6.38
Quote Progetto Sottof.								323.53	323.36	323.36		323.35		323.24	323.24	323.34			
Dist. Parz. Progetto Sottof.								0.17	1.78		4.25		4.40		1.78	0.48			
Dist. Progetto Sottof.								-6.19	-6.03	-4.25		0.00		-4.40	6.18	6.28			
Quote Terreno	323.68	323.67						323.53				323.43	323.42				323.23	323.18	323.13
Distanze Terreno	-30.00	-28.94						-6.19				0.00	-1.27				-13.91	-16.65	-20.00

SCAVI E BONIFICHE	
SCOTICO	12.52 m
BONIFICA	7.53 mq

RILEVATI	
RILEVATO	0.74 mq
TERRENO VEGETALE	3.57 m

SOVRASTRUTTURA STRADALE	
STRATO DI USURA	8.60 m
STRATO DI BINDER	8.60 m
STRATO DI BASE	8.60 m
STRATO DI FONDAZIONE	1.79 mq

SEZIONE N. : 135
 Qt. prog. : 323.85
 Progr. Km : 2+680.000

Scala 1:200

Qt. rif. 310.000

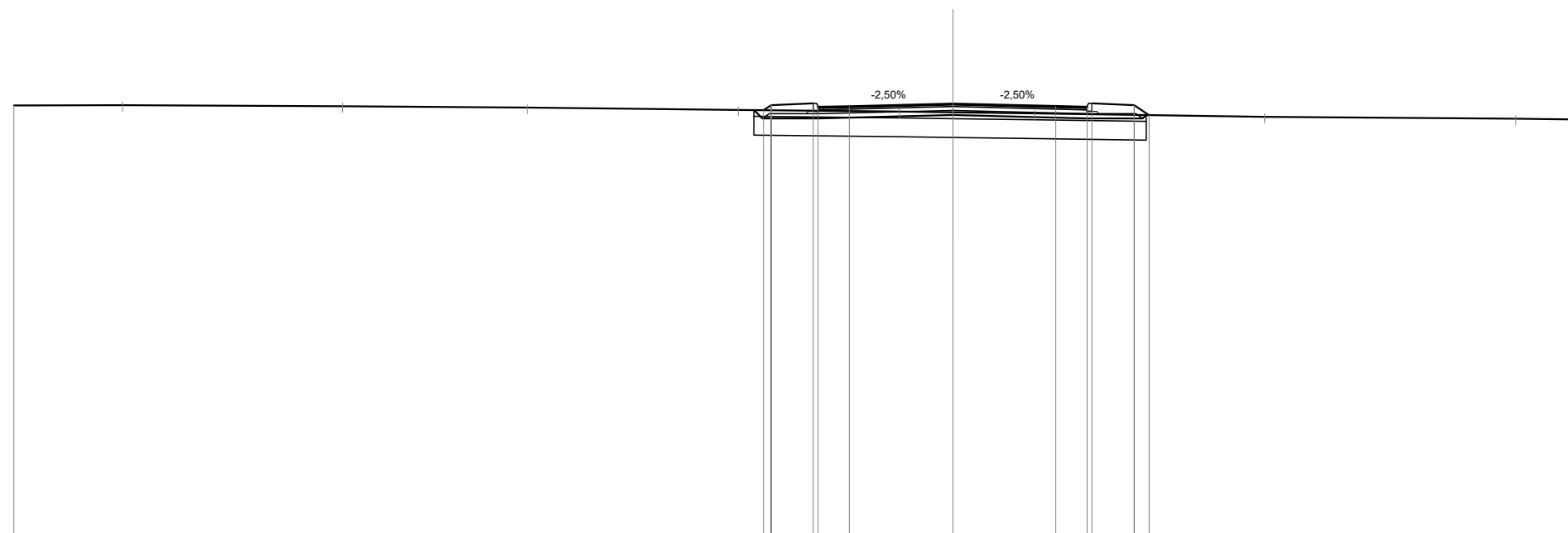

Quote Progetto Pavim.																				
Dist. Parz. Progetto Pavim.																				
Dist. Progetto Pavim.																				
Quote Progetto Sottof.																				
Dist. Parz. Progetto Sottof.																				
Dist. Progetto Sottof.																				
Quote Terreno	323.80	323.80	323.77	323.72	323.65	323.65	323.60	323.57	323.54	323.54	323.43	323.37	323.34							
Distanze Terreno	-30.00	-26.53	-19.50	-13.59	-6.85	-1.71	0.00	-2.61	9.96	17.98	20.00									

SCAVI E BONIFICHE	
SCOTICO	13.07 m
BONIFICA	7.84 mq

RILEVATI	
RILEVATO	1.45 mq
TERRENO VEGETALE	3.81 m

SOVRASTRUTTURA STRADALE	
STRATO DI USURA	8.97 m
STRATO DI BINDER	8.97 m
STRATO DI BASE	8.97 m
STRATO DI FONDAZIONE	1.85 mq

SEZIONE N. : 137
 Qt. prog. : 324.15
 Progr. Km : 2+720.000

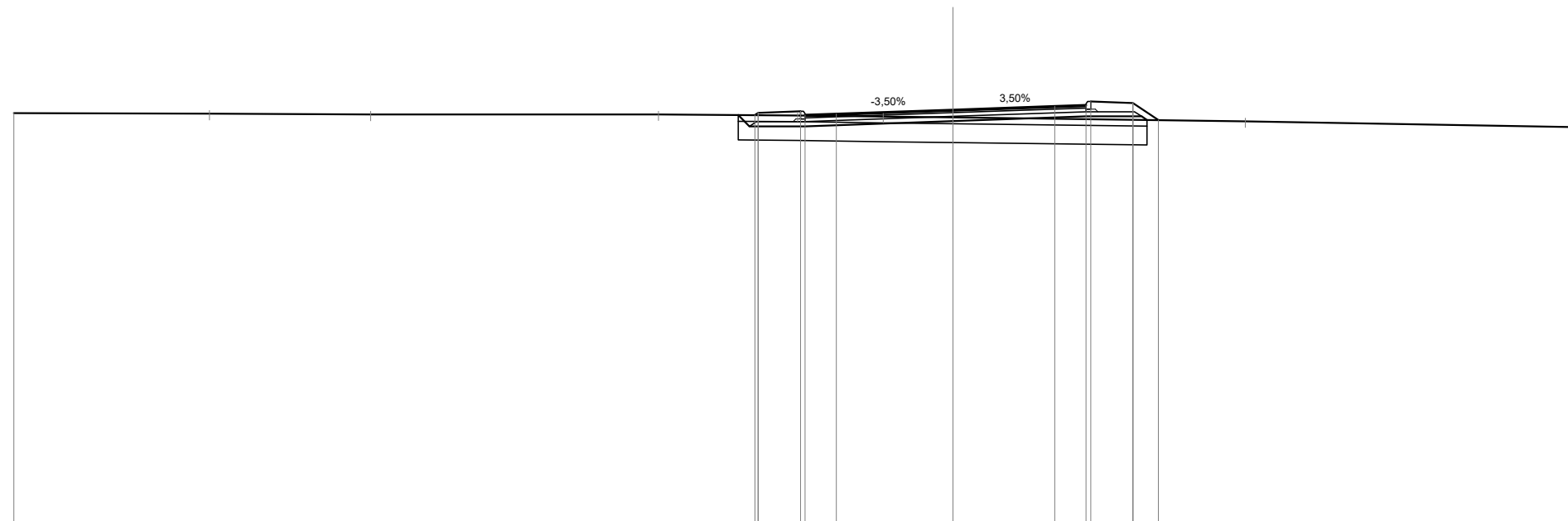

Scala 1:200

Qt. rif. 311.000

Quote Progetto Pavim.						323.99	324.05	324.11	323.99	324.02	324.15	324.27	324.30	324.42	324.37	323.82
Dist. Parz. Progetto Pavim.						1.35	1.00	3.72	3.25	1.00	1.35	0.82				
Dist. Progetto Pavim.						-6.33	-6.22	-4.87	-4.72	-3.72	0.00	3.25	4.25	4.40	5.75	6.57
Quote Progetto Sottof.						323.99	323.63	323.63			323.79	323.94	323.94	323.94	323.83	323.83
Dist. Parz. Progetto Sottof.						0.36	1.78		4.72		4.25	1.78	0.17			
Dist. Progetto Sottof.						-6.86	-6.50	-4.72			0.00	4.25	6.03	6.20		
Quote Terreno	324.05	324.03	324.01	324.01	323.98	323.94	323.91	323.79	323.79	323.79	323.60					
Distanze Terreno	-30.00	-23.75	-18.60	-9.41	-4.96	-2.23	0.00	9.34	20.00							

SCAVI E BONIFICHE	
SCOTICO	12.62 m
BONIFICA	7.56 mq

RILEVATI	
RILEVATO	1.33 mq
TERRENO VEGETALE	3.81 m

SOVRASTRUTTURA STRADALE	
STRATO DI USURA	8.77 m
STRATO DI BINDER	8.77 m
STRATO DI BASE	8.77 m
STRATO DI FONDAZIONE	1.82 mq

SEZIONE N. : 136
 Qt. prog. : 323.99
 Progr. Km : 2+700.000

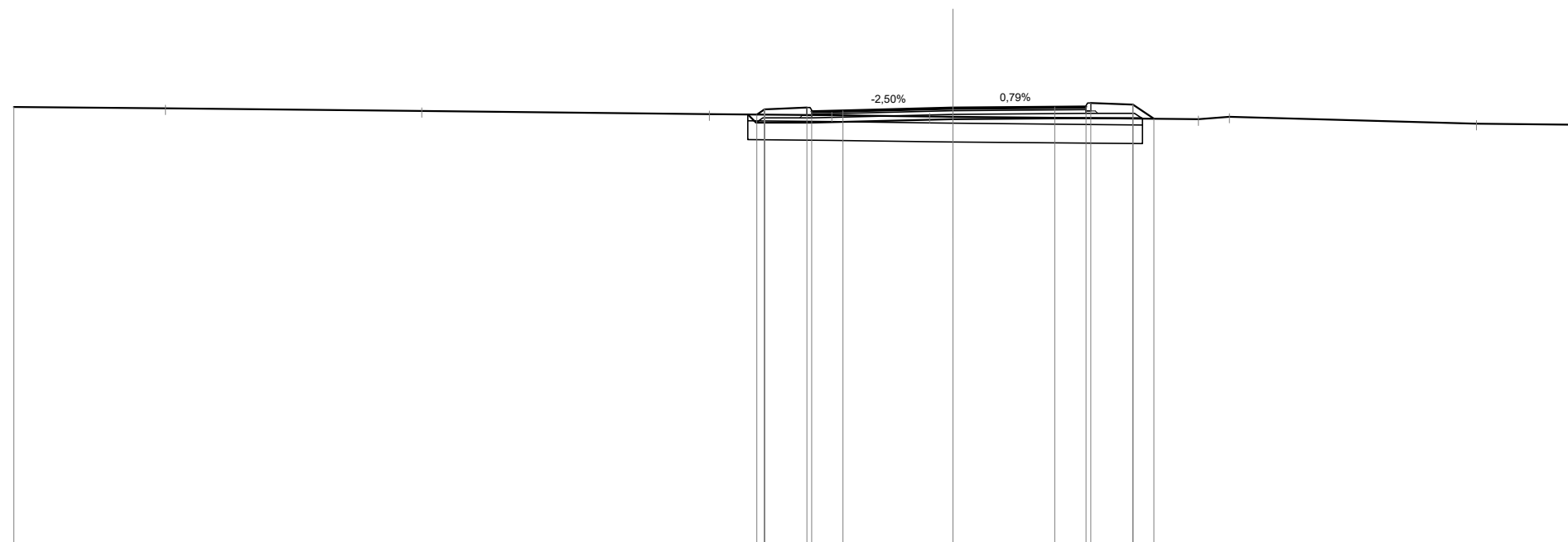

Scala 1:200

Qt. rif. 310.000

Quote Progetto Pavim.							323.77	323.94				323.99	324.01	324.02	324.14	324.09	323.64
Dist. Parz. Progetto Pavim.							1.35	1.00	3.52			3.25	1.00	1.35	0.67		
Dist. Progetto Pavim.							-6.27	-6.02				0.00	-3.25	4.25	4.40	5.75	6.42
Quote Progetto Sottof.							323.77	323.51				323.63	323.66	323.66	323.64	323.64	
Dist. Parz. Progetto Sottof.							0.26	1.78			4.52	4.25	1.78	0.00	0.00	0.00	
Dist. Progetto Sottof.							-6.55	-6.29			-4.52	0.00	-4.25	6.03	6.06		
Quote Terreno	324.02	323.97	323.89	323.79	323.75	323.70	323.71	323.70	323.70	323.70	323.70	323.70	323.62	323.70	323.48	323.45	
Distanze Terreno	-30.00	-25.15	-16.97	-7.78	-3.87	-0.74	0.00	0.00	0.00	0.00	0.00	0.00	7.84	8.83	16.72	20.00	

SCAVI E BONIFICHE	
SCOTICO	13.27 m
BONIFICA	7.96 mq

RILEVATI	
RILEVATO	4.71 mq
TERRENO VEGETALE	4.94 m

SOVRASTRUTTURA STRADALE	
STRATO DI USURA	9.00 m
STRATO DI BINDER	9.00 m
STRATO DI BASE	9.00 m
STRATO DI FONDAZIONE	1.87 mq

SEZIONE N. : 138
 Qt. prog. : 324.45
 Progr. Km : 2+740.000

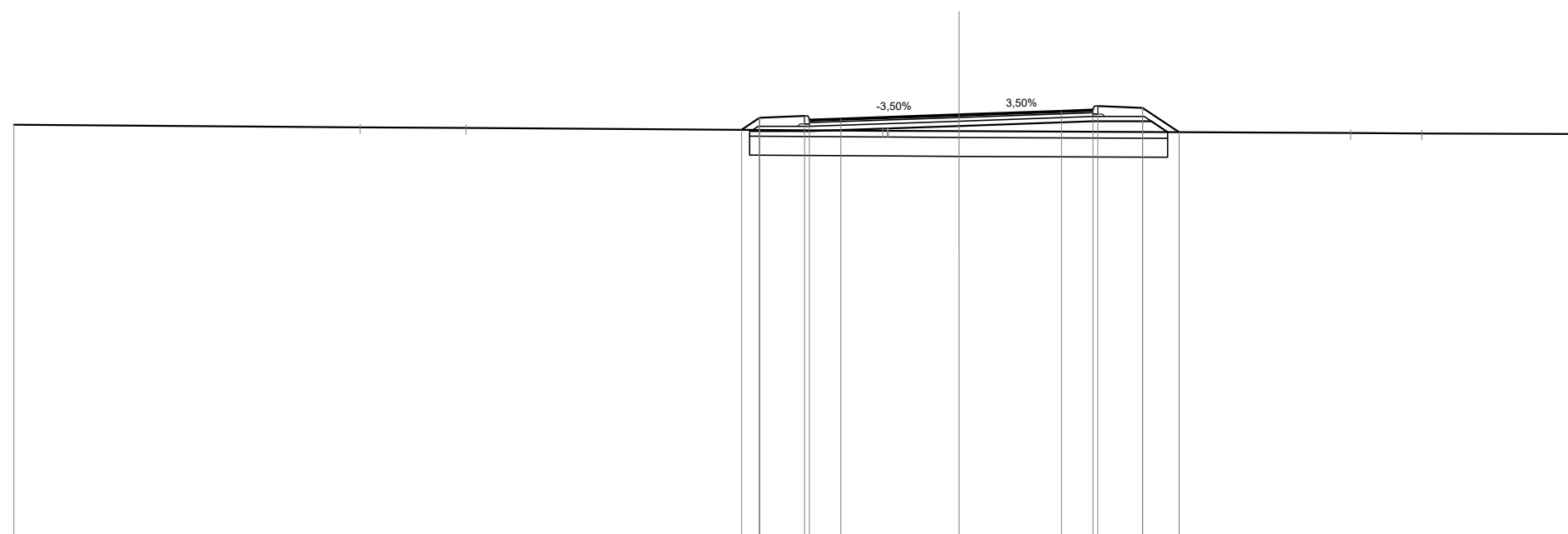

Scaletta 1:200

Qt. rif. 311.000

Quote Progetto Pavim.					323.96	324.34	324.40	324.28	324.32		324.45		324.56	324.60	324.72	324.66	323.89			
Dist. Parz. Progetto Pavim.					0.57	1.43	1.00	3.75		3.25		1.00	1.43	1.15						
Dist. Progetto Pavim.					-6.90	-6.33	-4.90	-4.75	-3.75		0.00		-3.25	-4.25	-4.40	-5.83	-6.98			
Quote Progetto Sottof.					323.96	323.92	323.92				324.09		324.24	324.24	324.24	324.24	323.89			
Dist. Parz. Progetto Sottof.					0.04	1.85		4.75			4.25		1.85	0.52						
Dist. Progetto Sottof.					-6.64	-6.60	-4.75				0.00		-4.25	-6.10	-6.62					
Quote Terreno	324.12		324.04							323.93	323.93						323.86	323.85		323.83
Distanze Terreno	-30.00		-19.01							-2.42	-2.25						-12.43	-14.69		-20.00

SCAVI E BONIFICHE	
SCOTICO	13.64 m
BONIFICA	8.18 mq

RILEVATI	
RILEVATO	5.43 mq
TERRENO VEGETALE	5.34 m

SOVRASTRUTTURA STRADALE	
STRATO DI USURA	9.08 m
STRATO DI BINDER	9.08 m
STRATO DI BASE	9.08 m
STRATO DI FONDAZIONE	1.94 mq

SEZIONE N. : 139
 Qt. prog. : 324.84
 Progr. Km : 2+760.000

Scala 1:200

Qt. rif. 311.000

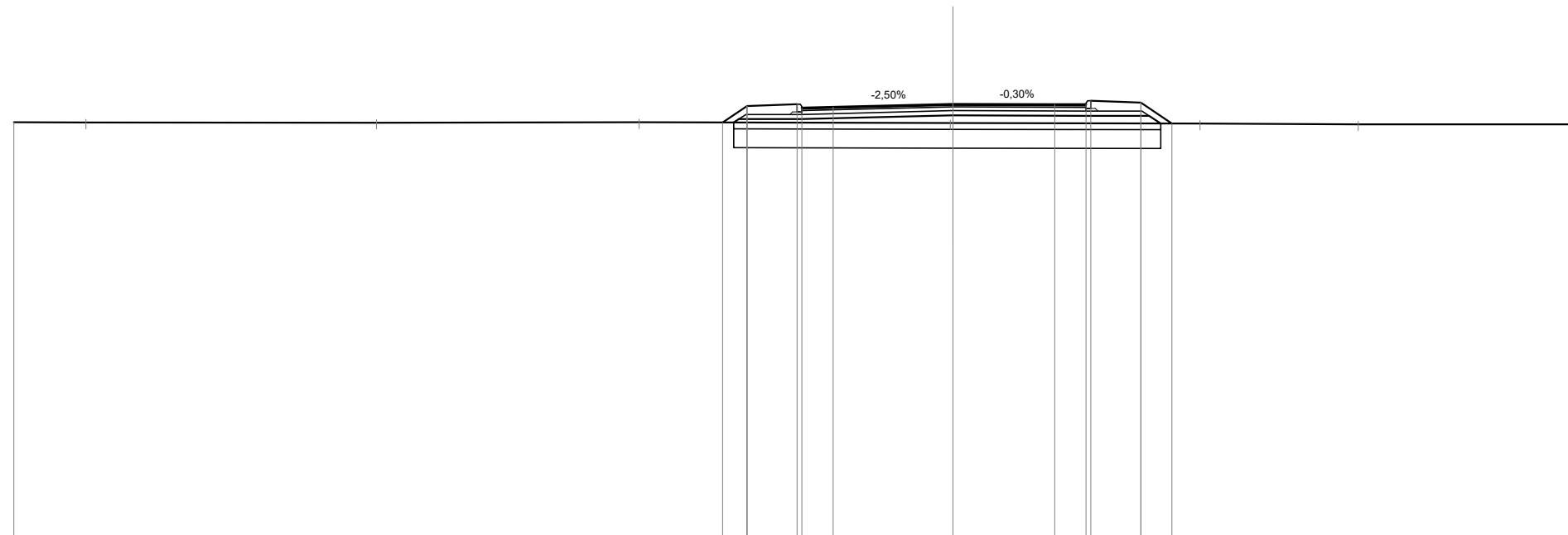

Quote Progetto Pavim.						324.25	324.78	324.84	324.72	324.74		324.84		324.83	324.83	324.95	324.88	324.22		
Dist. Parz. Progetto Pavim.						0.78	1.60	1.00		3.83		3.25		1.00	1.60	1.00				
Dist. Progetto Pavim.						-7.36	-6.58	-4.98	-4.83	-3.83		0.00		-3.25	-4.25	-4.40	-6.00	-7.00		
Quote Progetto Sottof.						324.25	324.36	324.36				324.48		324.47	324.47	324.22				
Dist. Parz. Progetto Sottof.						0.16	2.01			4.83		4.25		2.01	0.37					
Dist. Progetto Sottof.						-7.00	-6.84	-4.83				0.00		-4.25	-6.26	-6.63				
Quote Terreno	324.26	324.25		324.25		324.26					324.23	324.23					324.22		324.19	324.19
Distanze Terreno	-30.00	-27.69		-18.42		-10.03					-0.08	0.00					-7.89		-12.94	-20.00

SEZIONE N. : 140
 Qt. prog. : 325.29
 Progr. Km : 2+782.586

Scala 1:200

Qt. rif. 312.000

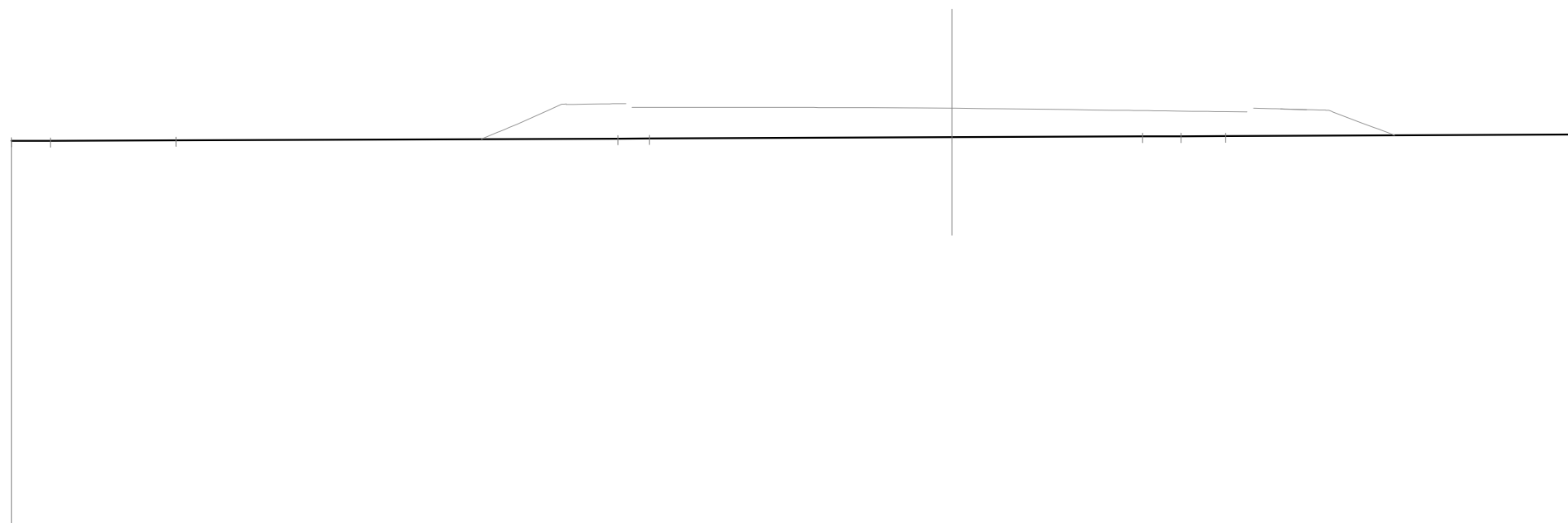

Quote Progetto Pavim.	
Dist. Parz. Progetto Pavim.	
Dist. Progetto Pavim.	
Quote Progetto Sottof.	
Dist. Parz. Progetto Sottof.	
Dist. Progetto Sottof.	
Quote Terreno	-30.00 324.25 324.25 -24.75 324.27 -10.65 324.32 324.33 0.00 324.37 6.08 324.40 7.31 324.39 8.73 324.40 20.00 324.46
Distanze Terreno	-30.00 -28.75 -24.75 -10.65 -9.65 0.00 6.08 7.31 8.73 20.00