



REGIONE PUGLIA



PROVINCIA di FOGGIA



COMUNE di FOGGIA



Progetto Uno

Progetto Uno s.r.l. via Napoli, 116 - cap. 95127 Catania (CT)
amm.: Oliver Lutz - cod. fisc. 0585151074 Tel.:3386386396

PROGETTO DEFINITIVO

**Progetto per la realizzazione di un impianto eolico denominato "Wind 1"
della potenza nominale di 54,4 MW nel Comune di Foggia loc. Cantone**

*Decreto Legislativo 29 dicembre 2003 n° 387- Attuazione della direttiva 2001/77/CE
Promozione dell'energia elettrica da fonti rinnovabili nel mercato interno dell'elettricità'*

ELABORATO

Percorsi ed Adeguamenti Stradali

FORMATO	SCALA	CODICE DOCUMENTO					NOME FILE
A4	/	SOC.	DISC.	TIPO DOC.	PROG.	REV.	PRO-PROG-REL-017
		PRO	PROG	REL	017		

Coordinamento e Progettazione	 Studio Tecnico Associato ing. Giovanni Bruno - arch. G.Farinola Viale Europa, 62/a Foggia (FG) Tel. 0881373998 - 3356013949 E-mail: ingbruno@tiscali.it	Studio Archeologico	 Dott. Antonio Mesisca Via Aldo Moro B/5 82021 Apice (BN) Tel. 3271616306 E-mail: mesisca.antonio@virgilio.it
Studio Geologico e consulenza ambientale	Geol. Francesco Ferrante Studio di Geologia Tecnica e Ambientale Via Attilio Benvenuto, 76 - Foggia (FG) Tel. 0881742216 - 3385654577 E-mail: ferrantegeo@gmail.com	Studio Agronomico	Dott. Antonio Totaro Viale L. Da Vinci, 1 Manfredonia (FG) Tel. 3486403829 E-mail: atotaro033@gmail.com
Studio Paesaggistico	Arch. Giuseppe Farinola Viale Europa, 62/a Foggia (FG) Tel. 0881373998 - 3387535391 E-mail: agfarinola@virgilio.it	Studio Elettrico	 Sciacca & Partners S.r.l. C.so Vittorio Emanuele III, 51 96015 Francofonte (SR) CF e P.IVA: 01871700892 E-mail: noi@sciaccapartners.it
Rilievo Topografico	 Studio Tecnico Dott. Agr. Rocco Iacullo Via Padre Antonio da Olivadi, 89 - Foggia Tel. 0881665592 - 3930051965 E-mail: studioiacullo@gmail.com	Studio Acustico	Ing. Michele Russo Via Mascagni, 1 - Margherita di Savoia (BT) Tel. 3495343724 E-mail: russomicheleing@gmail.com

Rev.	Data	Oggetto della revisione	Elaborazione	Verifica	Approvazione

	Progetto Definitivo	Codice Elaborato: PRO-PROG-REL-017
		Data: 27/01/2023
	Percorsi ed Adeguamenti Stradali	Revisione: 00
		Pagina: 2

1	Premessa	3
2	Metodologia di rilievo	4
3	Risultanze	4

	Progetto Definitivo	Codice Elaborato:	PRO-PROG-REL-017
		Data:	27/01/2023
	Percorsi ed Adeguamenti Stradali	Revisione:	00
		Pagina:	3

1 Premessa

Il presente documento è relativo al Progetto per la realizzazione di un impianto di produzione di energia elettrica mediante lo sfruttamento del vento, da ubicarsi nel Comune di Foggia (FG), proposto dalla società Progetto UNO Srl. L'impianto è costituito da n. 8 aerogeneratori (modello VESTAS V172 – diametro 172 mt., altezza hub 114 mt.) localizzati nel Comune di Foggia, di potenza unitaria 6.8 MW, per una potenza complessiva dell'impianto di 54.4 MW.

Gli aerogeneratori si trovano nel Comune di Foggia (FG). Il tracciato del cavidotto di collegamento alla Stazione utente attraversa il Comune di Foggia (FG). L'impianto sarà allacciato alla Stazione Elettrica Terna "Lucera", tramite connessione a 36 kV.

Attraverso questa relazione si riporteranno le risultanze derivanti dall'esame dei potenziali percorsi necessary per il trasporto delle apparecchiature, delle torri, delle navicelle e delle pale sul luogo oggetto di intervento. Nella seguente Tabella 1 si elencano le posizioni degli aerogeneratori e della Cabina Utente che costituiscono il Progetto, espresse in coordinate WGS 84, fuso UTM 33:

Aerogeneratori	Coordinate – EPSG32633 UTM 33 WGS84		Coordinate geografiche - EPSG4326 Lat Long	
	A1	545815	4600130	41,551523207
A2	546243	4600428	41,554182646	15,554516802
A3	546671	4600726	41,556841849	15,559672027
A4	547098	4601332	41,562275008	15,564839839
A5	547908	4601213	41,561155058	15,574544098
A6	547798	4600558	41,555262116	15,573172840
A7	547302	4600392	41,553796459	15,567212234
A8	545778	4599308	41,544121600	15,548855734
Cabina Utente	545272	4599271	41,543817000	15,542789000

Tabella 1: Posizione aerogeneratori e C.U.(WGS 84 UTM 33)

Gli 8 aerogeneratori e la C.U. si trovano ubicate al c. terreni del commune di Foggia ai seguenti fogli:

Aerogeneratori	Foglio	Particella
A1	26	181
A2	26	152
A3	26	153
A4	3	258
A5	10	14
A6	10	455/33
A7	10	21/280
A8	26	171
Cabina Utente	26	171

Tabella 2: Inquadramento catastale aerogeneratori e C.U.

Progetto Uno	Progetto Definitivo	Codice Elaborato: PRO-PROG-REL-017
	Percorsi ed Adeguamenti Stradali	Data: 27/01/2023
Revisione: 00		
Pagina: 4		



Fig.1: localizzazione area di intervento su ortofoto

2 Metodologia di rilievo

La valutazione dei potenziali percorsi si è basata sulle specifiche progettuali dettate da Vestas attraverso il proprio “Wind Farm Roads Reuirements” che si riporta in allegato, valutando lo stato e la criticità rilevate dall’esame delle arterie stradali presenti.

In particolare sono stati presi in considerazione, come hub di partenza:

- Il porto di Manfredonia - Manfredonia (FG)
- Pugliese Industria Meccanica – Fossacesia (CH)

e, da essi, valutati una serie di percorsi alternativi.

3 Risultanze

A valle delle specifiche dettate da Vestas, viene riportato il report completo dei sopralluoghi effettuati contenente i potenziali percorsi e le criticità rilevate.

Wind farm Roads Requirements

DMS no: 0054-6051

Version No.	Date	Prepared by	Revised by	Approved by	Description of changes
7	06/09/18	RGOBA / LUSPR	LGB / ADMAD	TKJ / PIPRE	E2E requirements conformity
8	26/04/19	RGOBA / LUSPR / DDLCO	LGB / ADMAD	TKJ / PIPRE	V162 Requirements.
9	03/09/19	LUSPR / DDLCO	LGB / ADMAD	TKJ	Update wording.

T13 0054-6051 Ver 05 - Approved- Exported from DMS: 2020-01-09 by FRADR

CONTENTS

1.	INTRODUCTION	3
2.	WIND FARM ROADS SPECIFICATIONS AND DESIGN	4
2.1	USEFUL ROAD WIDTH	4
2.2	MAXIMUM LONGITUDINAL SLOPE	5
2.3	VERTICAL ALIGNMENT OF ROADS	6
2.4	LATERAL CROSS-FALL	8
2.5	ROAD OVERHEAD CLEARANCE	8
2.6	BEARING CAPACITY AND SUBGRADE	9
2.7	PAVEMENT	10
2.8	BRIDGES AND CROSSINGS	13
2.9	EXISTING ROADS	13
2.10	DRAINAGE SYSTEM	13
2.11	TURNING AREAS	14
2.12	TRUCK LAY-BAY AREAS	14
2.13	TRAFFIC SIGNALS	Error! Bookmark not defined.
3.	ROADS MAINTENANCE	15
4.	INSPECTION AND CONTROL	16
4.1	GRADDED AGGREGATE	16
4.2	COMPACTION AND SOIL BEARING CAPACITY	16
4.3	TRANSPORT TRIAL	17
	ANNEX: BEND WIDENING	18

1. INTRODUCTION

The purpose of this specification is to establish the minimum road design and construction technical requirements for the roads to transport and install all Vestas wind turbine components . Each wind farm road design shall be defined by a dedicated road calculus report.

For the avoidance of doubt, the requirements set forth herein are necessary for a safe transport of the wind turbine components. However, such requirements alone are not sufficient to fully design and perform the wind farm roads. The design and construction of the roads and other wind farm related civil works shall require a specific calculus and design carried out by qualified experts considering all the calculus hypothesis to define all the applicable situations during the wind farm lifetime and construction period.

Very Important: Addendum to the present document

In the event that any of the standards set forth herein cannot be fulfilled because of technical or economic reasons, an alternative solution shall be found in order to allow a safe wind turbine installation.

Such alternative solutions shall be reviewed and agreed by Vestas prior to the execution of works. The agreed special solutions can be attached as an addendum to the present document in order to be applied in a specific project as valid alternative.

Furthermore, in some specific geographical areas it may be possible to customize and/or to optimize some of the requirements of the present specification. These complementary modifications can also be attached as an addendum to the present document for exclusive application on such areas.

2. WIND FARM ROADS SPECIFICATIONS AND DESIGN

2.1 USEFUL ROAD WIDTH

The minimum useful width to assure a safe transportation of the wind turbine components must be 4,5 m on straight sections of the wind farm roads.

On bends sections of the wind farm roads, it is recommended to perform a truck simulation with adequate software to determine the necessary widening. Otherwise, the recommendations from the Annex can be used as a first approach. Upon request, Vestas can perform a specific simulation to determine the optimum bend widening.

When crawler cranes are used during installation of wind turbines, the useful road width will be increased up to the width of the crawler crane plus a margin of, at least, 10 cm to allow its safe circulation (to be confirmed with crane company).

As a reference, in case of using a narrow track crawler crane, the most common useful road width on this case is 6 m. In case of using conventional crawler cranes, the above criterion is also valid and the most common useful road width is around 11 m. Final road width has to be confirmed with crane company based on final layout design.

Important note:

It is highly recommended to agree the road width with Vestas according to the site characteristics and cranes availability in order to optimize the total costs of the project and to have the safest and fastest way.

2.2 MAXIMUM LONGITUDINAL SLOPE

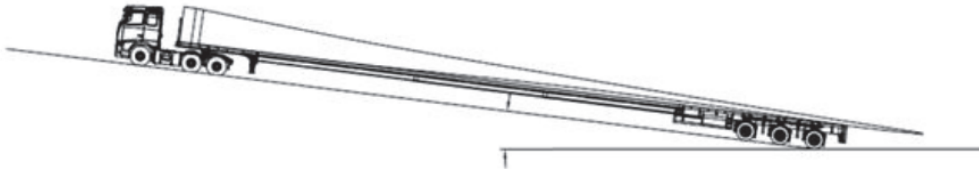

Figure 1: Longitudinal slope

The maximum longitudinal slope that the wind turbine component trucks can overcome is directly related to the quality of the pavement.

As a general design criterion, on dirt roads made of gravel or a graded aggregate where good pavement conditions cannot be assured due to often rain and/or possible poor construction and quality control or other circumstances, the wind farms maximum road longitudinal slope shall not exceed a value of 10% on straight stretches.

In mountain areas where it could not be possible to design roads with the above maximum slope due to environmental restrictions, the pavement shall be improved by using a suitable solution like concrete slabs or other one. On extreme cases where the slope may be higher than 14%, it shall be communicated to Vestas in all cases.

Once roads have been carried on site up to final pavement surface compacted and prior to wind turbine component transport, Vestas shall always validate and evaluate road condition to define the most suitable transport solution.

In case of relevant bends (low radius and high angle), the maximum longitudinal slope will be reduced on a proportional way to its complexity, and it is recommended not to exceed 7%.

If crawler cranes are going to circulate over the roads, it will be considered the maximum slope that these cranes can overcome. Allowable slopes for the crane total or partially assembled, and completely disassembled shall be evaluated in order to adapt the roads to those situations.

2.3 VERTICAL ALIGNMENT OF ROADS

The vertical alignment of roads, in relation to (parabolic) vertical curves, must be in accordance with the following criteria:

The minimum required values of the vertical alignment parameters (as described in Figure 2:) are established in Table 1 for each wind turbine model.

WTG	Kv min.
V80, V90	300
V100, V105	350
V110, V112, V116, V117	400
V120, V126	450
V136, V150, V162	500

Table 1. Minimum Kv

Vertical radius parameter (Kv) calculation:

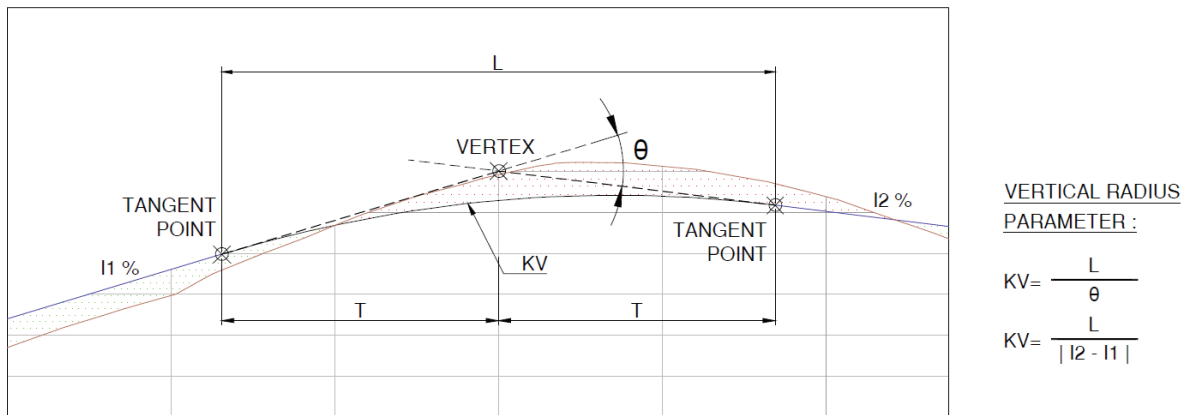
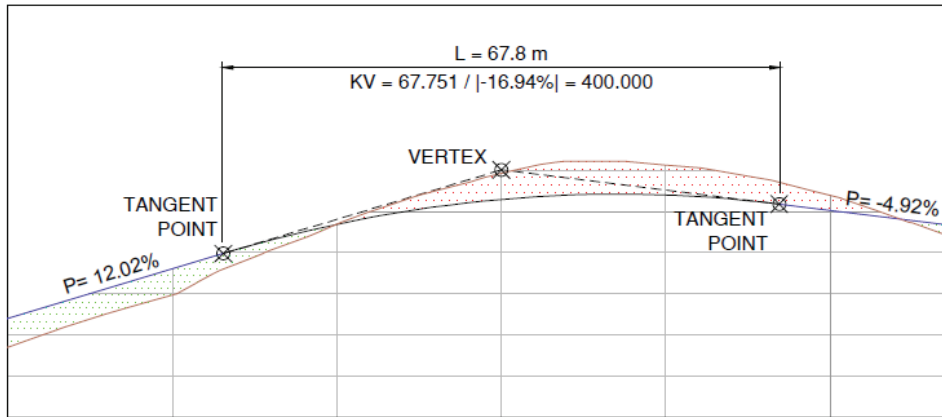

Figure 2: Representation of parameters for Vertical alignment

Convex radius example:

The following image shows an example of Kv calculation for a convex alignment:



CONVEX RADIUS EXAMPLE :

$KV = L / |I2 - I1|$
 $KV = 67.60 / | -4.9\% - 12.0\% |$
 $KV = 67.60 / | -16.9\% |$
 $KV = 400.00$

Figure 3: Representation of Convex Radius Example

Concave Radius Example:

The following image shows an example of Kv calculation for a concave alignment:

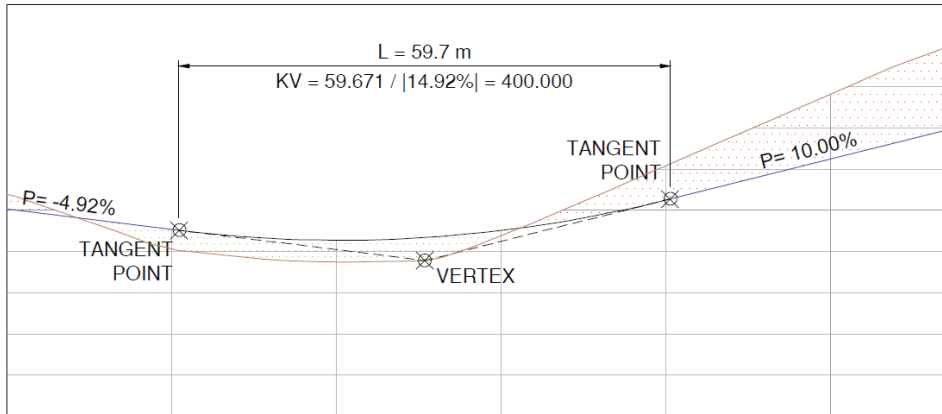

CONCAVE RADIUS

EXAMPLE :
 $KV = L / |I2 - I1|$
 $KV = 59.60 / | 10.0\% - (-4.9\%) |$
 $KV = 59.60 / | 14.9\% |$
 $KV = 400.00$

Figure 4: Representation of Concave Radius Example

2.4 LATERAL CROSS-FALL

In case that the designer decides to have a lateral cross-fall for rain water evacuation shall not exceed 2% from the centre of the road.



Figure 5: Longitudinal slope

2.5 ROAD OVERHEAD CLEARANCE

Road overhead clearance shall be at minimum 4,7 m from the pavement highest point. (This minimum value of 4,7 m depends upon the availability of special low bed hydraulic trailers for transport of tower sections, depends also on the final dimensions of the tower sections and depends on the blade tip overhang).

This value must be reviewed and approved by Vestas according to the specific project.

Any permanent obstacle or hazard situated overhead (e.g. power and telephone lines) shall be signalled with appropriate visual markers that will be kept in place throughout the duration of the construction and installation of the wind farm.

2.6 BEARING CAPACITY AND SUBGRADE

Roads Bearing Capacity

The wind farm roads load bearing capacity shall be at minimum 2 Kg/cm². As an additional criterion the wind farm roads will be designed to bear a truck axle-load of 12 Tm.

Designer shall consider all hypothesis that would be applicable to the wind farm roads during its construction and lifetime. Dedicated road bearing capacity calculus has to be elaborated to ensure the transport of all machinery involved in the project.

The verification of the bearing capacity will be performed by static plate bearing test on site. The accredited laboratory that makes the static plate bearing test shall set up the acceptance criteria on it to confirm the required bearing capacity. To have an approximate reference, the results of the plate baring test should have the bulk modulus E_{v2} greater than 50 MPa and the modulus ratio E_{v2}/E_{v1} lower than 3. These figures shall be confirmed or modified by the accredited laboratory that makes the plate bearing test according to the final plate to be used.

In case of transport or crane mobilization will be done using sub-base layer, plate bearing tests will be done at sub-base layer following the same acceptable criteria mentioned above, therefore, road base design shall consider transport at road sub-base layer.

Subgrade

The soil survey shall characterize the soil on which the wind farm roads are to be constructed. To such purpose, soil samples (from beneath the topsoil) shall be taken in several representative points of the road network at intervals of 700 to 1000 meters. The collection of samples and performance of appropriate lab tests for soil characterization (California Bearing Ratio CBR, grading, plasticity, Proctor, etc.) shall be planned and carried out by a geotechnical expert.

The subgrade layer (below topsoil) upon which the roads are built shall have a minimum CBR value between 11 and 20.

In the event that such minimum CBR values are not achieved, the subgrade shall be accordingly improved by applying the most suitable method (lime or cement soil stabilization, addition of stone material, geotextile, etc.), depending on the kind of soil and following the instructions from an expert roads designer.

2.7 PAVEMENT

Roadbed Layer

The pavement of access and site roads (whether newly built or refurbished) shall be formed, as an initial recommendation, at minimum by a 15 cm thickness roadbed layer of graded aggregate, compacted to 98% Modified Proctor. Minimum thickness shall be defined by road calculus design report based on the AASHTO or applicable code.

Graded aggregate maximum grain size shall be lower than 20 mm and fines content shall be lower than 10% (<10% pass #200mm sieve).

The graded aggregate used as pavement shall have low plasticity in order to prevent mud formation when it rains. Under no circumstances shall a graded aggregate with plasticity index (PI) value greater than 9 be accepted.

Graded aggregate grain size shall be between the following limits depending on its source: natural or crushed gravel:

Natural Graded Aggregate

NATURAL GRADED AGGREGATE SIEVE SIZE: EN-933-2, ASTM C136										
% CUMULATIVE PASSING										
Graded Aggregate	EN	40	25	20	8	4	2	0,5	0,25	0,063
	ASTM	1,5	1	3/4	3/8	N°4	N°10	N°40	N°60	N°230
0/20	max	-	100	100	75	61	50	32	24	11
	min	-	100	80	45	32	25	10	5	0

Table 2. Roadbed layer Natural grain size limits.

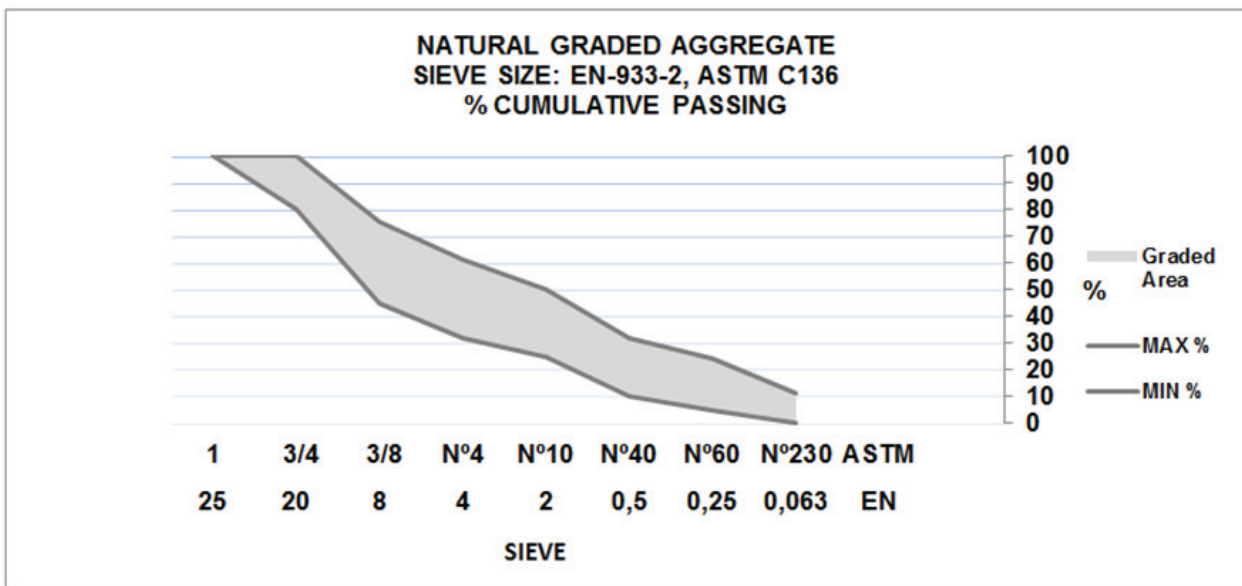

Figure 6: Roadbed layer Natural grain size limits.

Artificial Graded Aggregate

Table 3. Roadbed layer artificial grain size limits.

		ARTIFICIAL GRADED AGGREGATE SIEVE SIZE: EN-933-2, ASTM C136									
		% CUMULATIVE PASSING									
Graded Aggregate	EN	40	32	25	20	8	4	2	0,5	0,25	0,063
	ASTM	1,5	1,25	1	3/4	3/8	N°4	N°10	N°40	N°60	N°230
0/20	% max	-	-	100	100	73	54	40	24	18	9
	% min	-	-	100	75	45	31	20	9	8	0

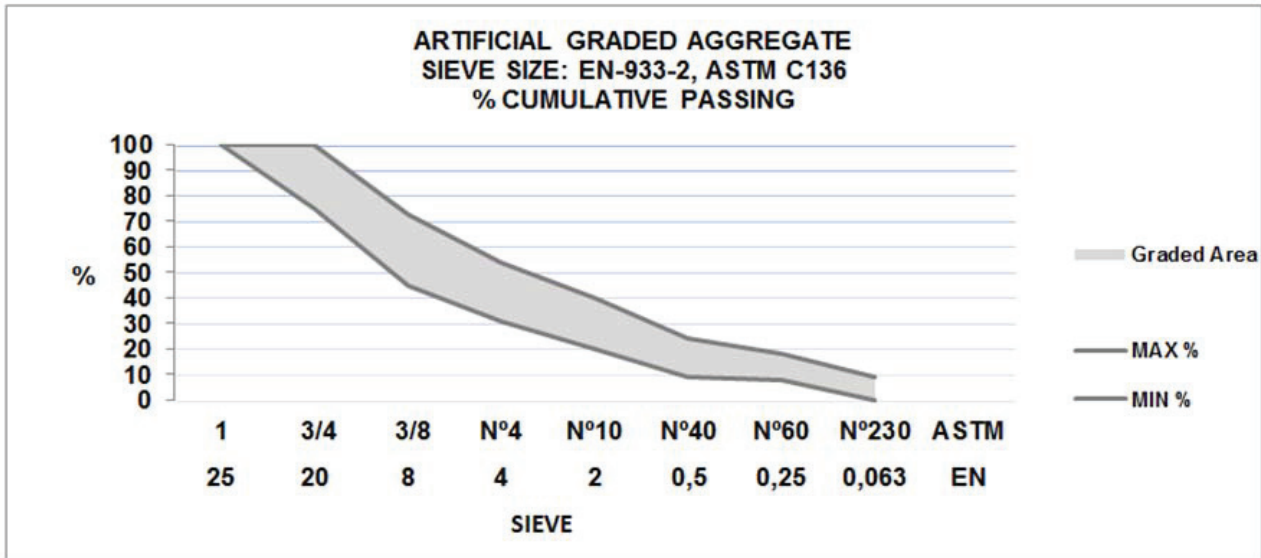

Figure 7: Roadbed layer artificial grain size limits.

Sub-base Layer

In case more than 20 cm thickness layer is required, a sub-base layer will be placed underneath the roadbed. The maximum grain size in the sub-base layer may be incremented up to 40 mm.

Graded aggregate grain size shall be between the following limits depending on its source: natural or crushed gravel:

Natural Graded Aggregate

		NATURAL GRADED AGGREGATE SIEVE SIZE: EN-933-2, ASTM C136								
		% CUMULATIVE PASSING								
Graded Aggregate	EN	40	25	20	8	4	2	0,5	0,25	0,063
	ASTM	1,5	1	3/4	3/8	N°4	N°10	N°40	N°60	N°230
0/40	max	95	90	84	63	46	35	23	18	9
	min	80	65	54	35	22	15	7	4	0

Table 4. Natural Subgrade layer grain size limits

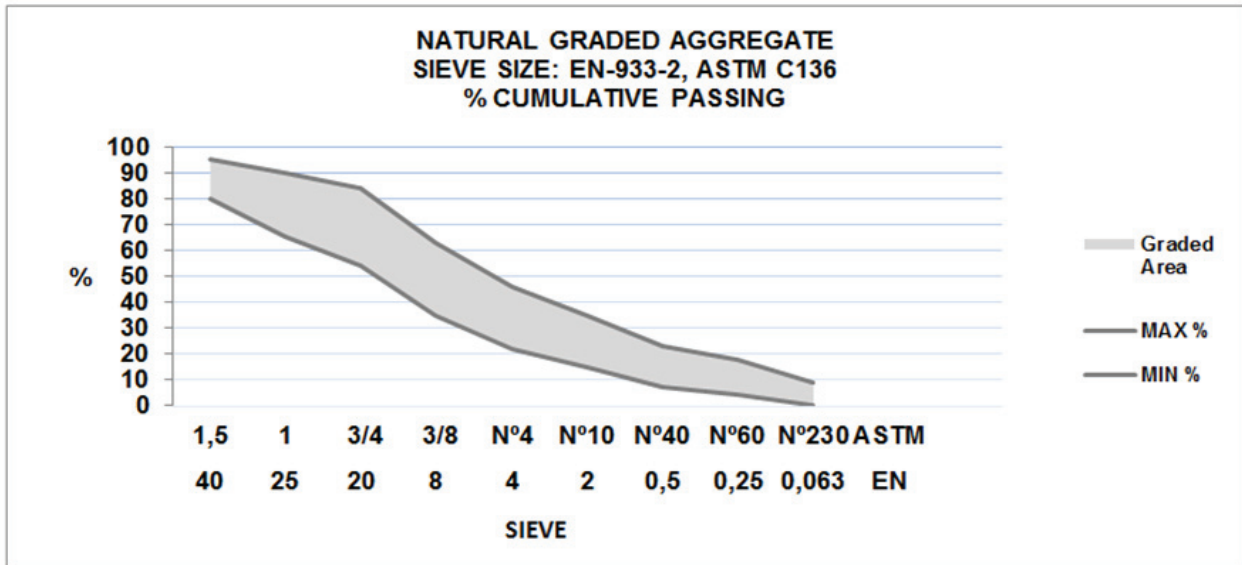

Figure 8: Natural Subgrade layer grain size limits.

Artificial Graded Aggregate

ARTIFICIAL GRADED AGGREGATE SIEVE SIZE: EN-933-2, ASTM C136											
% CUMULATIVE PASSING											
Graded Aggregate	EN	40	32	25	20	8	4	2	0,5	0,25	0,063
	ASTM	1,5	1,25	1	3/4	3/8	N°4	N°10	N°40	N°60	N°230
0/32	max	100	100	90	76	63	45	32	21	16	9
	min	100	88	65	52	40	26	15	7	4	0

Table 5. Artificial Subgrade layer grain size limits

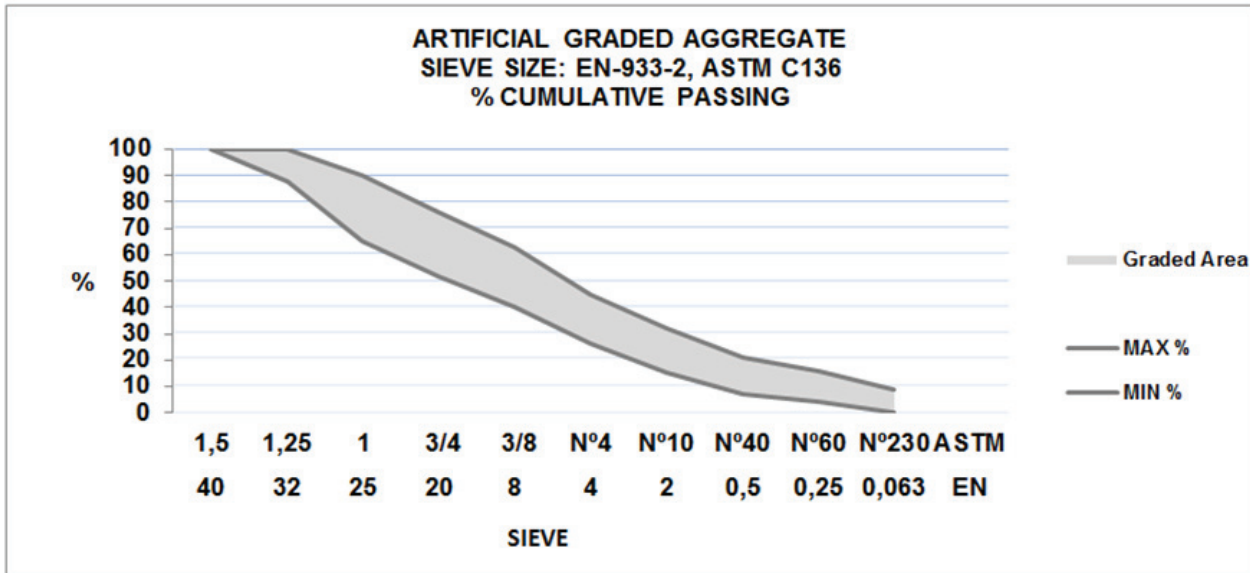

Figure 9: Artificial Subgrade layer grain size limits.

In the event that an improvement of the subgrade is required, and the proposed solution entails the use of geotextile or geogrid, recommendations from the supplier regarding the graded aggregate material may apply.

Additionally, if necessary, an special study of the sub-base layer shall be performed to ensure its suitable behaviour against compression, tensile and shear stresses.

In any case, the final design shall comply with the quality conditions demanded by Vestas herein and shall allow the transport of the components in safety conditions.

2.8 BRIDGES AND CROSSINGS

Special attention must be paid to bridges and other types of crossings to make sure their maximum bearing capacity is sufficient to allow the passage of loaded vehicles. In case of insufficient bearing capacity, an alternative itinerary shall be sought, or adequate technical solutions shall be put in place to allow trucks to transit safely. In any case, the load bearing capacity of bridges or crossings shall be communicated to Vestas that will review and approve it prior to the commencement of works.

2.9 EXISTING ROADS

Exceptionally, secondary roads with lower load bearing capacity and/or poor asphalted pavement may be used; however the passage of trucks may cause severe damage thereto. The improvement of these roads previous to the wind turbine components transportation and/or the repair after transport shall be evaluated and foreseen. The responsibility and costs for in-course or subsequent repairing and re-establishment of such roads will be not sustained by Vestas.

2.10 DRAINAGE SYSTEM

Road drainage shall be designed to control the flow of rain water alongside the roads and allow the road to self-drain. Whenever judged necessary by an expert technician, and following a hydrological basin and terrain gradient survey, the drainage system shall include paved or unpaved side ditches and masonry drains.

Cross drainage culvert shall be laid over, at least, 10 cm blinding concrete layer and covered by, at least, 5 cm of blinding concrete layer. Backfilling shall be covered with excavated material and graded aggregated layer as applied in the cross section.

In areas where the road needs to be provided with a lateral slope in order to ease drainage, the maximum gradient shall not exceed 2%. In any case, symmetry of the road section in relation to its centreline shall be maintained.

2.11 TURNING AREAS

In correspondence of the last WTG location at the end of dead-end site roads it is usually problematic for trucks to perform a 180° manoeuvre and exit from the same way they entered. In these locations an adequate turning area must be provided for the 180° manoeuvre of trucks. In some cases, part of the existing hardstand can be used for the manoeuvre. Whenever this is not possible for practical or safety reasons, a dedicated turn-around levelled and compacted area similar to Figure 10: In any case, the proposed solution shall be communicated to Vestas that will review and approve it prior to the commencement of works.

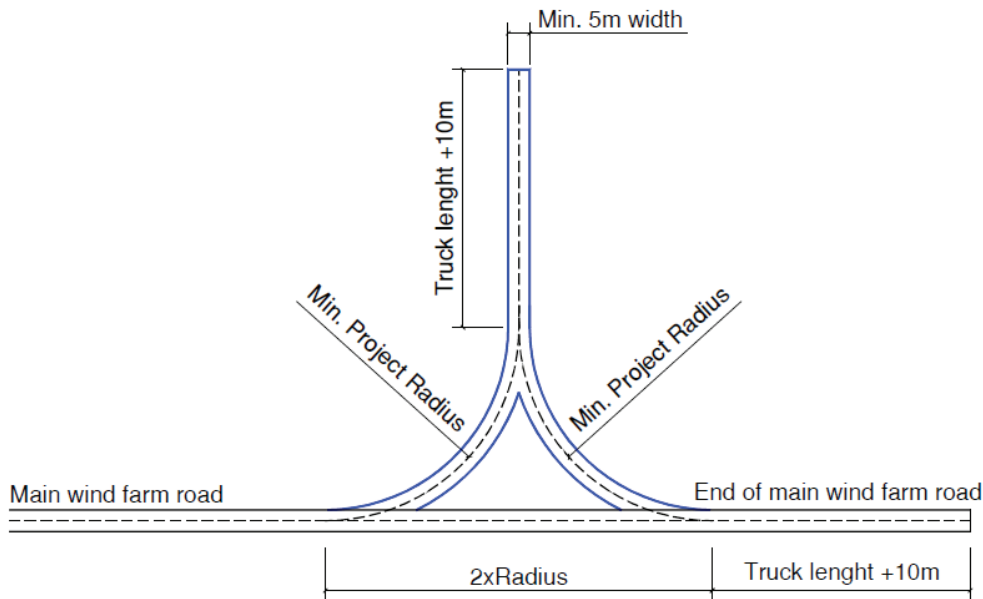

Figure 10: Turning Area Minimum Dimensions

2.12 TRUCK LAY-BAY AREAS

All site and access roads only 5m wide and more than 5 Km long shall be provided with truck lay-by areas designed to have an extra width of 5 m and 50 m long. Such lay-by areas shall be established at intervals of 4 to 5 km, as well as in correspondence of any critical road point if so requested by Vestas. The critical points shall be agreed upon separately prior to executing any contractual agreement. Lay-by areas shall be clear of any debris, levelled, compacted and free of any drainage system.

2.13 TRAFFIC SIGNALS

The needed traffic signals will be placed along the road to assure a safety driving according to the Safety Plan of the project.

In particular, proper signalling for high slopes and vehicles top speed will be installed.

3. ROADS MAINTENANCE

Access and site roads shall be adequately maintained throughout the duration of the wind farm construction and installation period, including:

- a. Periodically watering the roads when dust is created by the transit of vehicles. This is done to minimize segregation of the pavement's fine aggregates and prevent health and safety problems.
- b. Periodically cleaning all side ditches and masonry drains to ensure no obstructions prevent rain water from flowing through thus, deteriorating the efficiency of the drainage system.
- c. In case of more than 2 weeks from plate bearing test performing and transports trucks and/or crane mobilization, additional watering, compaction and base layer thickness increased could be requested by Vestas to ensure safety transport. After these updates, additional plate bearing tests would be requested to check road bearing capacity.
- d. In case of using crawler crane assembly mobilization between the turbine locations it is necessary to perform a base layer finished regularization by adding and compaction, at least, 10cm graded aggregated thickness to ensure road quality and regularization.

4. INSPECTION AND CONTROL

4.1 GRADDED AGGREGATE

Graded aggregate grain size shall be as mention in paragraph 2.7.

For any provided production volume, at least four (4) samples have to be tested, adding one (1) more every ten thousand cubic meters (10.000 m³), or excess fraction every fifty thousand cubic meters.

The following test will be performed on each sample. These tests shall be done according to the international regulation that applies in the project region:

- Modified Proctor, according to ASTM D1557-09, AASHTO T180-01 (or its national equivalent standard).
- Liquid limit and plasticity index*, according to ASTM D-4318, AASHTO T90-00 (2004) or ISO/TS 17892-12 (or its national equivalent standard).
- Grain Size by sieving**, according to EN 933-1:2012 or ASTM C-136 (or its national equivalent standard).

4.2 COMPACTION AND SOIL BEARING CAPACITY

As mention in paragraph 2.6., static plate-bearing test is recommended to assure the well compaction of the roads and its bearing capacity.

Static plate bearing test shall be done in a staggered pattern where the truck wheel is expected to be in contact with road surface. In case transversal section has cutting and embankment, the plate bearing test shall be done in the embankment part as shown in the following figure:

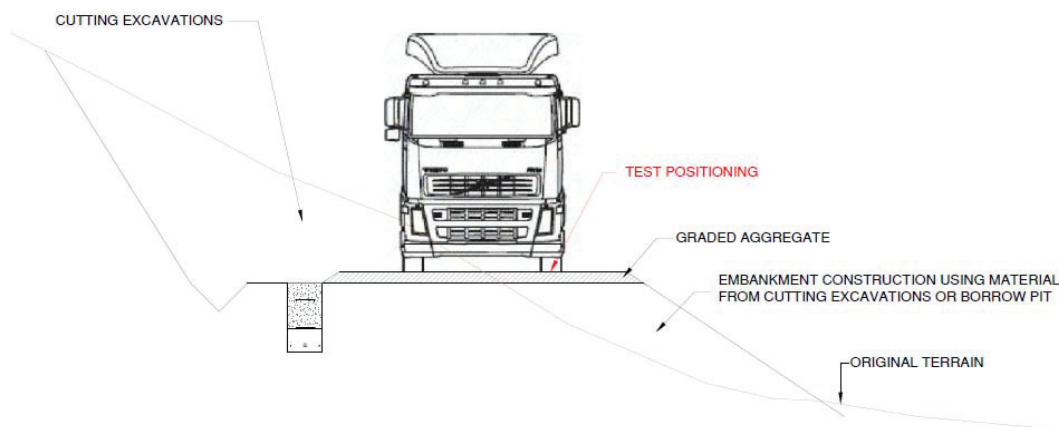

Figure 11: Plate Bearing Test Positioning

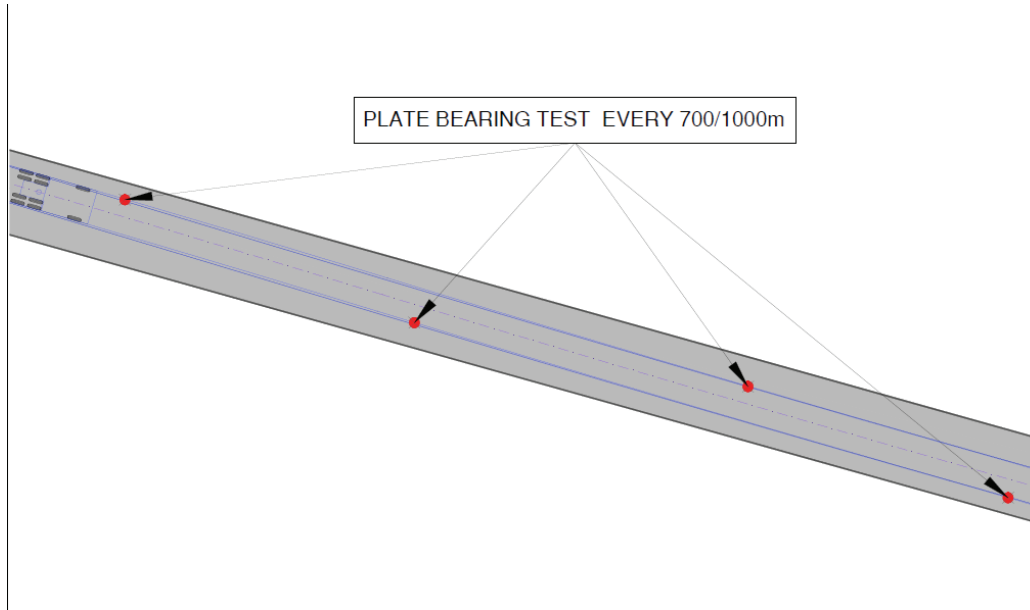

Figure 12: Plate Bearing Test Positioning

Nuclear density test is recommended to assure the well compaction of the roads and the required bearing capacity. If these tests were not available, another equivalent one can be proposed. The nature of such tests shall be established by an expert based on the geotechnical characteristics of the wind farm and the materials which are used for the roads.

4.3 TRANSPORT TRIAL

If deemed necessary, an unloaded transport trial using the longest vehicle may be conducted to verify the geometrical suitability of site and access roads.

ANNEX: BEND WIDENING

The following charts are provided as an orientation to determine the necessary widening on low radius bends. It is important to note that the following sketch is not considering the affection area caused by the blade overhang. So that, for a higher accuracy, it is recommended to use adequate truck simulation software. Upon request, Vestas can perform a specific simulation to determine the optimum bend widening and the clear and free of obstacles necessary area to avoid interferences between the blade and the site conditions (natural soil, trees, existing buildings etc), not only outside the bend but also inside.

The following sketch is the key to understand the different bend widening according to the wind turbine model and the bending radius:

Key:

- *1 : Angle formed by the turning of the road
- *2 : Bending radius.
- *3 : External side of the extra widening, with respect to the center of the bending radius.
- *4 : Internal side of the extra widening, with respect to the center of the bending radius.
- *5 : External side of the blade swept area, with respect to the center of the bending radius.
- *6 : Internal side of the blade swept area, with respect to the center of the bending radius.
- *7 : Parameter to locate the extra widening.
 Note: Parameters every 10 meters before & after the turning, and every 15 degrees along the turning
- *8 : All units provided are in meters.

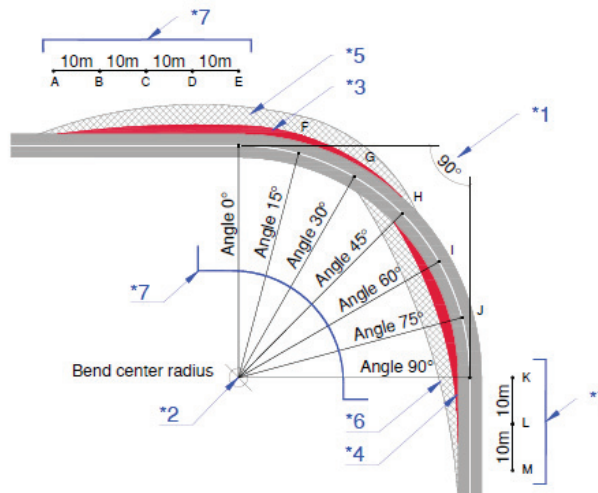

Figure 13: Bend widening dimensions location of values.

90° *1 BEND WIDENING - 5 METERS WIDE ROAD													
Radius *2	External *3								Internal *4				
	A	B	C	D	E	F	G	H	I	J	K	L	M
45m	-	-	-	0.5	0.7	0.9	0.6	-	-	-	0.3	-	-
50m	-	-	-	0,1	0,2	0,5	0,4	-	-	-	-	-	-
55m	-	-	-	-	-	0,2	0,2	-	-	-	-	-	-

Table 6. Bend Widening values.

60° BEND WIDENING - 5 METERS WIDE ROAD											
Radius	External					Internal					
	A	B	C	D	E	F	G	H	I	J	K
35m	-	-	-	0,1	0,2	-	-	-	-	-	-
40m	-	-	-	-	-	-	-	-	-	-	-
45m	-	-	-	-	-	-	-	-	-	-	-

60° Bend widening diagram:

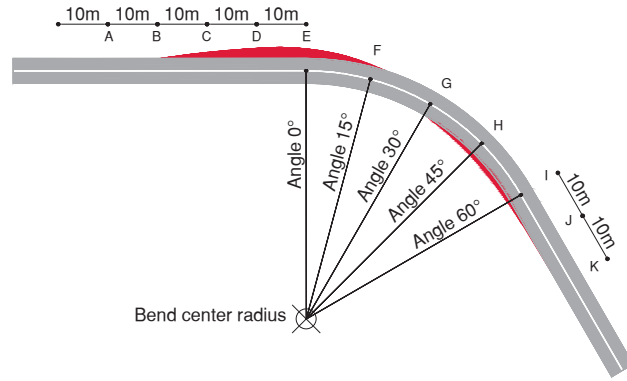

90° BEND WIDENING - 5 METERS WIDE ROAD													
Radius	External						Internal						
	A	B	C	D	E	F	G	H	I	J	K	L	M
35m	-	-	-	0.1	0.2	0.2	-	-	-	-	-	-	-
40m	-	-	-	-	-	-	-	-	-	-	-	-	-
45m	-	-	-	-	-	-	-	-	-	-	-	-	-

90° Bend widening diagram:

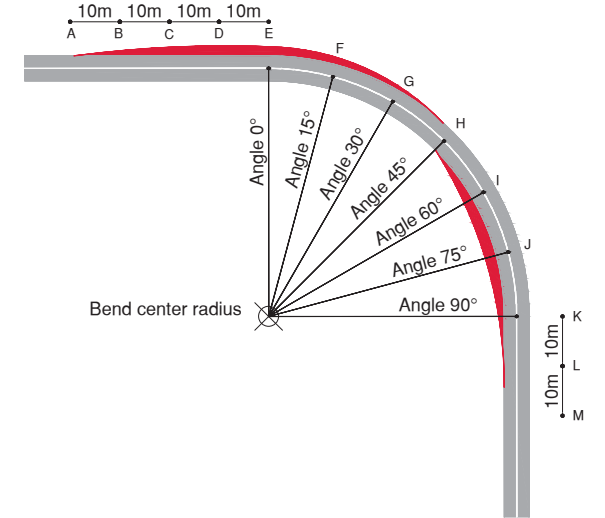

60° BEND WIDENING - 6 METERS WIDE ROAD											
Radius	External					Internal					
	A	B	C	D	E	F	G	H	I	J	K
35m	-	-	-	-	-	-	-	-	-	-	-
40m	-	-	-	-	-	-	-	-	-	-	-
45m	-	-	-	-	-	-	-	-	-	-	-

90° BEND WIDENING - 6 METERS WIDE ROAD													
Radius	External						Internal						
	A	B	C	D	E	F	G	H	I	J	K	L	M
35m	-	-	-	-	-	-	-	-	-	-	-	-	-
40m	-	-	-	-	-	-	-	-	-	-	-	-	-
45m	-	-	-	-	-	-	-	-	-	-	-	-	-

60° BEND WIDENING - 6.5 METERS WIDE ROAD											
Radius	External					Internal					
	A	B	C	D	E	F	G	H	I	J	K
35m	-	-	-	-	-	-	-	-	-	-	-
40m	-	-	-	-	-	-	-	-	-	-	-
45m	-	-	-	-	-	-	-	-	-	-	-

90° BEND WIDENING - 6.5 METERS WIDE ROAD													
Radius	External						Internal						
	A	B	C	D	E	F	G	H	I	J	K	L	M
35m	-	-	-	-	-	-	-	-	-	-	-	-	-
40m	-	-	-	-	-	-	-	-	-	-	-	-	-
45m	-	-	-	-	-	-	-	-	-	-	-	-	-

120° BEND WIDENING - 5 METERS WIDE ROAD															
Radius	External							Internal							
	A	B	C	D	E	F	G	H	I	J	K	L	M	N	O
35m	-	-	-	0.1	0.2	0.2	0.2	-	-	-	-	-	-	-	-
40m	-	-	-	-	-	-	-	-	-	-	-	-	-	-	-
45m	-	-	-	-	-	-	-	-	-	-	-	-	-	-	-

120° Bend widening diagram:

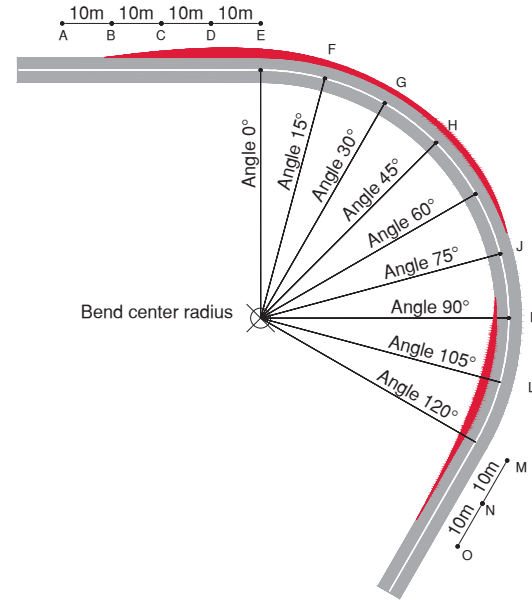

150° BEND WIDENING - 5 METERS WIDE ROAD																	
Radius	External									Internal							
	A	B	C	D	E	F	G	H	I	J	K	L	M	N	O	P	Q
35m	-	-	-	0.2	0.4	0.3	0.2	0.1	-	-	-	-	-	-	-	-	-
40m	-	-	-	-	0.2	0.2	-	-	-	-	-	-	-	-	-	-	-
45m	-	-	-	-	-	-	-	-	-	-	-	-	-	-	-	-	-

150° Bend widening diagram:

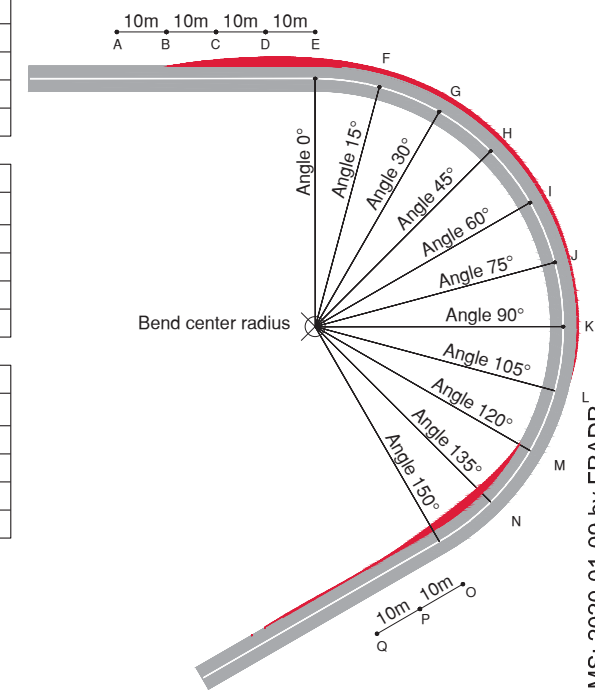

120° BEND WIDENING - 6 METERS WIDE ROAD															
Radius	External							Internal							
	A	B	C	D	E	F	G	H	I	J	K	L	M	N	O
35m	-	-	-	-	-	-	-	-	-	-	-	-	-	-	-
40m	-	-	-	-	-	-	-	-	-	-	-	-	-	-	-
45m	-	-	-	-	-	-	-	-	-	-	-	-	-	-	-

150° BEND WIDENING - 6 METERS WIDE ROAD																	
Radius	External									Internal							
	A	B	C	D	E	F	G	H	I	J	K	L	M	N	O	P	Q
35m	-	-	-	-	-	-	-	-	-	-	-	-	-	-	-	-	-
40m	-	-	-	-	-	-	-	-	-	-	-	-	-	-	-	-	-
45m	-	-	-	-	-	-	-	-	-	-	-	-	-	-	-	-	-

120° BEND WIDENING - 6.5 METERS WIDE ROAD															
Radius	External							Internal							
	A	B	C	D	E	F	G	H	I	J	K	L	M	N	O
35m	-	-	-	-	-	-	-	-	-	-	-	-	-	-	-
40m	-	-	-	-	-	-	-	-	-	-	-	-	-	-	-
45m	-	-	-	-	-	-	-	-	-	-	-	-	-	-	-

150° BEND WIDENING - 6.5 METERS WIDE ROAD																	
Radius	External									Internal							
	A	B	C	D	E	F	G	H	I	J	K	L	M	N	O	P	Q
35m	-	-	-	-	-	-	-	-	-	-	-	-	-	-	-	-	-
40m	-	-	-	-	-	-	-	-	-	-	-	-	-	-	-	-	-
45m	-	-	-	-	-	-	-	-	-	-	-	-	-	-	-	-	-

Design has been defined considering the following truck dimensions:

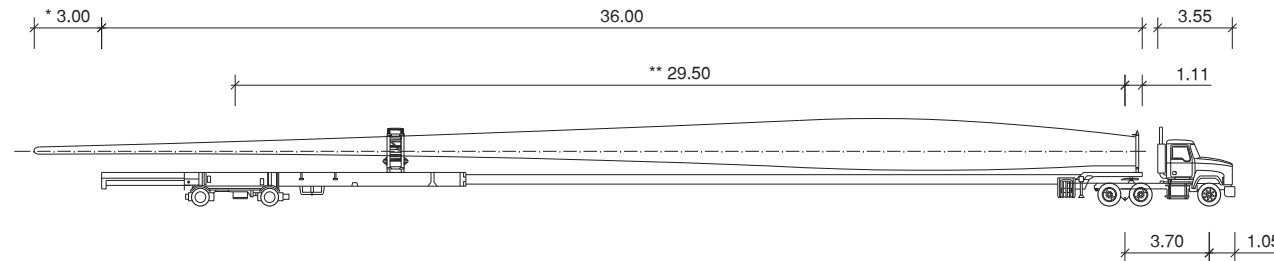

*The blade overhang requires an additional area to be cleared and free of obstacles outside the bend. The width of this additional area will be equal to the blade overhang. This additional area will be parallel to the road extra-widening.

**The distance between the axels requires an additional area to be cleared and free of obstacles inside the bend. This additional area will change depending of the truck and the bending radius and should be checked case-by-case.

-Different dimensions will lead to substantially different results.
-All units provided are in meters.

DESIGN REQUIREMENTS	
Minimum vertical curve parameter	$K_v = L / i_1 - i_2 = 300$
Maximum slope on gravel road	9%
Maximum slope on concrete road	14%
Minimum radius	35m
Min. straight length before/after the bend *	75m
* Additional bend wides provided in this drawing, will not be valid if this minimum straight length are not respected.	

60° BEND WIDENING - 5 METERS WIDE ROAD											
Radius	External						Internal				
	A	B	C	D	E	F	G	H	I	J	K
40m	-	-	-	0,6	0,6	-	-	-	-	-	-
45m	-	-	-	0,3	0,4	-	-	-	-	-	-
50m	-	-	-	-	-	-	-	-	-	-	-

60° Bend widening diagram:

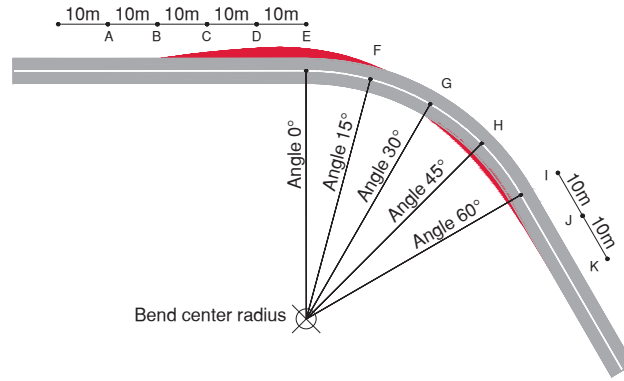

90° BEND WIDENING - 5 METERS WIDE ROAD													
Radius	External							Internal					
	A	B	C	D	E	F	G	H	I	J	K	L	M
40m	-	-	-	0,7	0,6	0,4	0,3	0,2	-	-	0,3	-	-
45m	-	-	-	0,4	0,4	0,2	0,1	0,1	-	-	-	-	-
50m	-	-	-	-	-	-	-	-	-	-	-	-	-

90° Bend widening diagram:

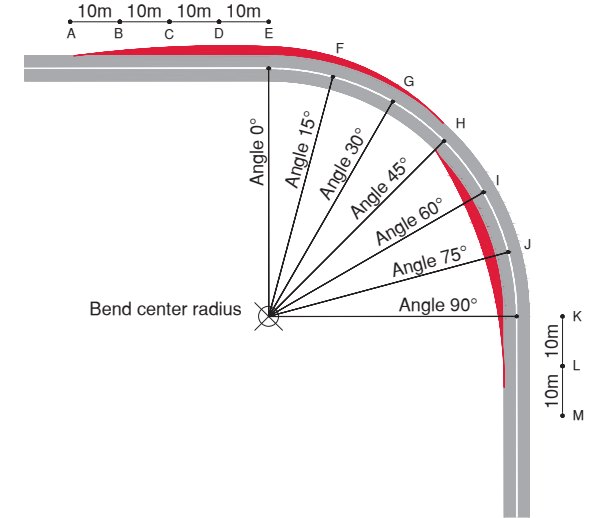

60° BEND WIDENING - 6 METERS WIDE ROAD											
Radius	External						Internal				
	A	B	C	D	E	F	G	H	I	J	K
40m	-	-	-	-	-	-	-	-	-	-	-
45m	-	-	-	-	-	-	-	-	-	-	-
50m	-	-	-	-	-	-	-	-	-	-	-

90° BEND WIDENING - 6 METERS WIDE ROAD													
Radius	External							Internal					
	A	B	C	D	E	F	G	H	I	J	K	L	M
40m	-	-	-	-	-	-	-	-	-	-	-	-	-
45m	-	-	-	-	-	-	-	-	-	-	-	-	-
50m	-	-	-	-	-	-	-	-	-	-	-	-	-

60° BEND WIDENING - 6.5 METERS WIDE ROAD											
Radius	External						Internal				
	A	B	C	D	E	F	G	H	I	J	K
40m	-	-	-	-	-	-	-	-	-	-	-
45m	-	-	-	-	-	-	-	-	-	-	-
50m	-	-	-	-	-	-	-	-	-	-	-

90° BEND WIDENING - 6.5 METERS WIDE ROAD													
Radius	External							Internal					
	A	B	C	D	E	F	G	H	I	J	K	L	M
40m	-	-	-	-	-	-	-	-	-	-	-	-	-
45m	-	-	-	-	-	-	-	-	-	-	-	-	-
50m	-	-	-	-	-	-	-	-	-	-	-	-	-

120° BEND WIDENING - 5 METERS WIDE ROAD															
Radius	External										Internal				
	A	B	C	D	E	F	G	H	I	J	K	L	M	N	O
40m	-	-	-	0,8	0,7	-	-	0,3	0,3	0,2	-	-	-	-	-
45m	-	-	-	0,2	0,2	-	-	0,3	0,3	0,2	-	-	-	-	-
50m	-	-	-	-	-	-	-	-	-	-	-	-	-	-	-

120° Bend widening diagram:

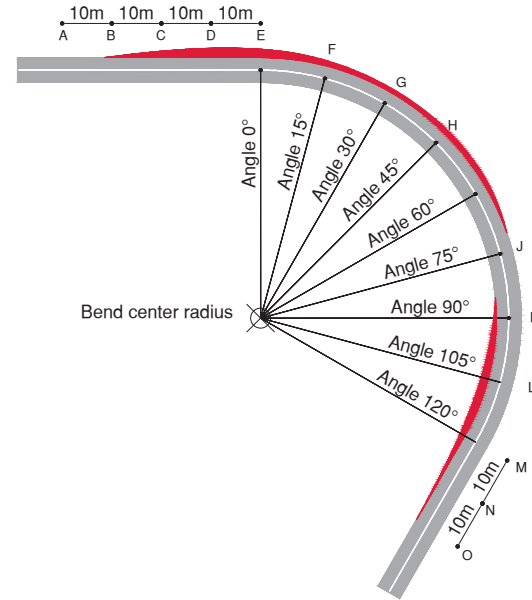

150° BEND WIDENING - 5 METERS WIDE ROAD															
Radius	External										Internal				
	A	B	C	D	E	F	G	H	I	J	K	L	M	N	O
40m	-	-	-	0,8	1,0	-	-	0,2	0,4	0,5	0,4	-	-	-	-
45m	-	-	-	0,4	0,3	-	-	-	-	0,3	0,2	-	-	-	-
50m	-	-	-	-	-	-	-	-	-	-	-	-	-	-	-

150° Bend widening diagram:

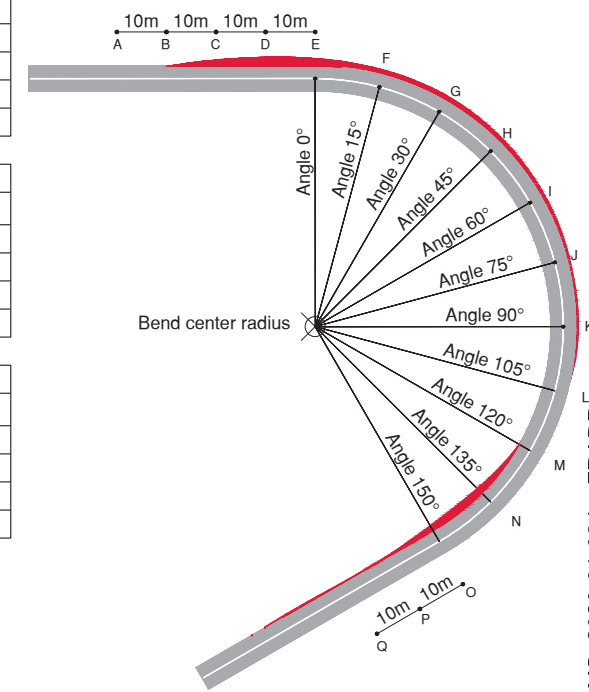

120° BEND WIDENING - 6 METERS WIDE ROAD															
Radius	External										Internal				
	A	B	C	D	E	F	G	H	I	J	K	L	M	N	O
40m	-	-	-	-	-	-	-	-	-	-	-	-	-	-	-
45m	-	-	-	-	-	-	-	-	-	-	-	-	-	-	-
50m	-	-	-	-	-	-	-	-	-	-	-	-	-	-	-

150° BEND WIDENING - 6 METERS WIDE ROAD															
Radius	External										Internal				
	A	B	C	D	E	F	G	H	I	J	K	L	M	N	O
40m	-	-	-	-	-	-	-	-	-	-	-	-	-	-	-
45m	-	-	-	-	-	-	-	-	-	-	-	-	-	-	-
50m	-	-	-	-	-	-	-	-	-	-	-	-	-	-	-

120° BEND WIDENING - 6.5 METERS WIDE ROAD															
Radius	External										Internal				
	A	B	C	D	E	F	G	H	I	J	K	L	M	N	O
40m	-	-	-	-	-	-	-	-	-	-	-	-	-	-	-
45m	-	-	-	-	-	-	-	-	-	-	-	-	-	-	-
50m	-	-	-	-	-	-	-	-	-	-	-	-	-	-	-

150° BEND WIDENING - 6.5 METERS WIDE ROAD															
Radius	External										Internal				
	A	B	C	D	E	F	G	H	I	J	K	L	M	N	O
40m	-	-	-	-	-	-	-	-	-	-	-	-	-	-	-
45m	-	-	-	-	-	-	-	-	-	-	-	-	-	-	-
50m	-	-	-	-	-	-	-	-	-	-	-	-	-	-	-

Design has been defined considering the following truck dimensions:

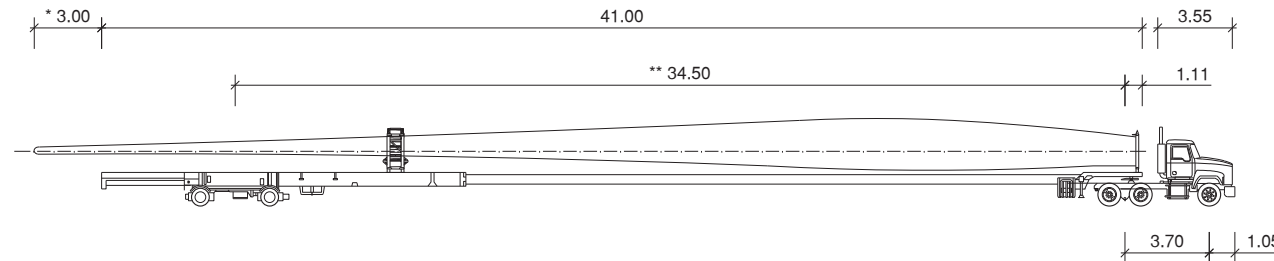

*The blade overhang requires an additional area to be cleared and free of obstacles outside the bend. The width of this additional area will be equal to the blade overhang. This additional area will be parallel to the road extra-widening.

**The distance between the axels requires an additional area to be cleared and free of obstacles inside the bend. This additional area will change depending of the truck and the bending radius and should be checked case-by-case.

-Different dimensions will lead to substantially different results.
-All units provided are in meters.

DESIGN REQUIREMENTS	
Minimum vertical curve parameter	$K_v = L / i_1 - i_2 = 300$
Maximum slope on gravel road	9%
Maximum slope on concrete road	14%
Minimum radius	40m
Min. straight length before/after the bend *	75m
* Additional bend widens provided in this drawing, will not be valid if this minimum straight length are not respected.	

60° BEND WIDENING - 5 METERS WIDE ROAD											
Radius	External					Internal					
	A	B	C	D	E	F	G	H	I	J	K
45m	-	-	-	1,0	1,3	0,6	-	-	0,3	-	-
50m	-	-	-	0,8	1,0	0,5	-	-	-	-	-
55m	-	-	-	0,2	0,6	0,4	-	-	-	-	-

60° Bend widening diagram:

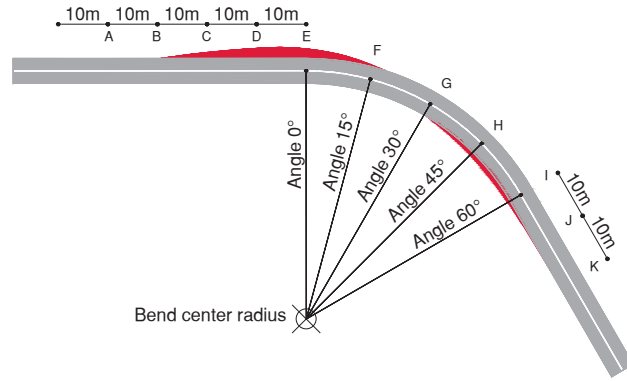

90° BEND WIDENING - 5 METERS WIDE ROAD													
Radius	External						Internal						
	A	B	C	D	E	F	G	H	I	J	K	L	M
45m	-	-	-	0,5	0,7	0,9	0,6	-	-	-	0,3	-	-
50m	-	-	-	0,1	0,2	0,5	0,4	-	-	-	-	-	-
55m	-	-	-	-	-	0,2	0,2	-	-	-	-	-	-

90° Bend widening diagram:

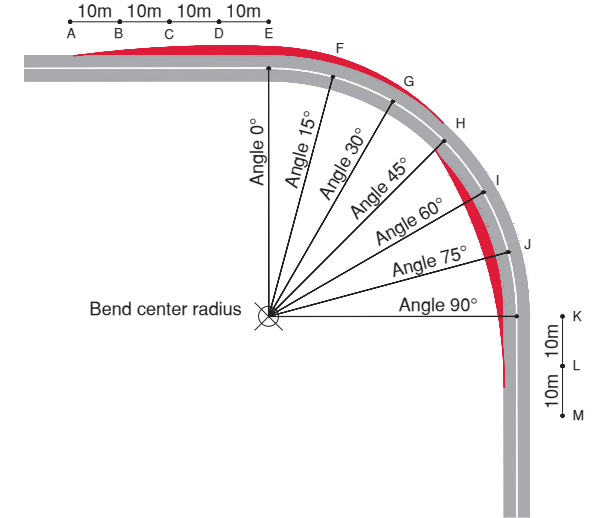

60° BEND WIDENING - 6 METERS WIDE ROAD											
Radius	External					Internal					
	A	B	C	D	E	F	G	H	I	J	K
45m	-	-	-	0,1	0,4	-	-	-	-	-	-
50m	-	-	-	-	-	-	-	-	-	-	-
55m	-	-	-	-	-	-	-	-	-	-	-

90° BEND WIDENING - 6 METERS WIDE ROAD													
Radius	External						Internal						
	A	B	C	D	E	F	G	H	I	J	K	L	M
45m	-	-	-	0,1	-	-	-	-	-	-	-	-	-
50m	-	-	-	-	-	-	-	-	-	-	-	-	-
55m	-	-	-	-	-	-	-	-	-	-	-	-	-

60° BEND WIDENING - 6.5 METERS WIDE ROAD											
Radius	External					Internal					
	A	B	C	D	E	F	G	H	I	J	K
45m	-	-	-	-	-	-	-	-	-	-	-
50m	-	-	-	-	-	-	-	-	-	-	-
55m	-	-	-	-	-	-	-	-	-	-	-

90° BEND WIDENING - 6.5 METERS WIDE ROAD													
Radius	External						Internal						
	A	B	C	D	E	F	G	H	I	J	K	L	M
45m	-	-	-	-	-	-	-	-	-	-	-	-	-
50m	-	-	-	-	-	-	-	-	-	-	-	-	-
55m	-	-	-	-	-	-	-	-	-	-	-	-	-

120° BEND WIDENING - 5 METERS WIDE ROAD															
Radius	External							Internal							
	A	B	C	D	E	F	G	H	I	J	K	L	M	N	O
45m	-	-	0,2	0,9	0,7	0,5	0,5	0,5	0,3	-	-	0,2	0,4	-	-
50m	-	-	0,1	0,5	0,3	0,3	0,2	0,2	0,2	-	-	-	0,3	-	-
55m	-	-	-	0,4	0,2	-	-	-	-	-	-	-	0,1	-	-

120° Bend widening diagram:

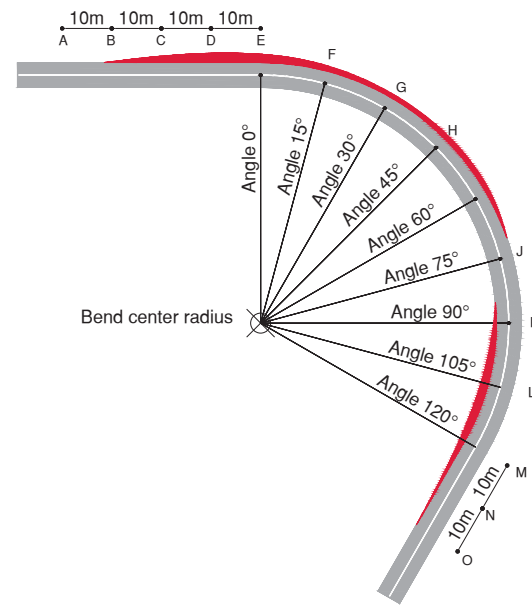

150° BEND WIDENING - 5 METERS WIDE ROAD																	
Radius	External									Internal							
	A	B	C	D	E	F	G	H	I	J	K	L	M	N	O	P	Q
45m	-	-	0,2	1,0	0,9	0,7	0,7	0,6	0,6	0,4	0,4	-	-	0,1	0,7	0,3	-
50m	-	-	0,2	0,6	0,4	0,4	0,3	0,3	0,3	0,2	0,2	-	-	-	0,3	0,1	-
55m	-	-	-	0,4	0,3	0,3	0,2	0,2	-	-	-	-	-	-	-	-	-

150° Bend widening diagram:

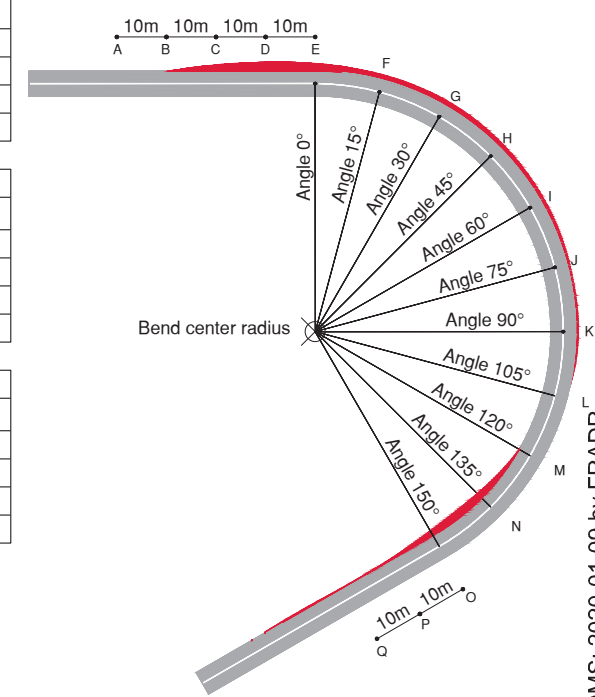

120° BEND WIDENING - 6 METERS WIDE ROAD															
Radius	External							Internal							
	A	B	C	D	E	F	G	H	I	J	K	L	M	N	O
45m	-	-	-	0,2	-	-	-	-	-	-	-	-	-	-	-
50m	-	-	-	-	-	-	-	-	-	-	-	-	-	-	-
55m	-	-	-	-	-	-	-	-	-	-	-	-	-	-	-

150° BEND WIDENING - 6 METERS WIDE ROAD																	
Radius	External									Internal							
	A	B	C	D	E	F	G	H	I	J	K	L	M	N	O	P	Q
45m	-	-	-	0,2	-	-	-	-	-	-	-	-	-	-	-	-	-
50m	-	-	-	-	-	-	-	-	-	-	-	-	-	-	-	-	-
55m	-	-	-	-	-	-	-	-	-	-	-	-	-	-	-	-	-

120° BEND WIDENING - 6.5 METERS WIDE ROAD															
Radius	External							Internal							
	A	B	C	D	E	F	G	H	I	J	K	L	M	N	O
45m	-	-	-	-	-	-	-	-	-	-	-	-	-	-	-
50m	-	-	-	-	-	-	-	-	-	-	-	-	-	-	-
55m	-	-	-	-	-	-	-	-	-	-	-	-	-	-	-

150° BEND WIDENING - 6.5 METERS WIDE ROAD																	
Radius	External									Internal							
	A	B	C	D	E	F	G	H	I	J	K	L	M	N	O	P	Q
45m	-	-	-	-	-	-	-	-	-	-	-	-	-	-	-	-	-
50m	-	-	-	-	-	-	-	-	-	-	-	-	-	-	-	-	-
55m	-	-	-	-	-	-	-	-	-	-	-	-	-	-	-	-	-

Design has been defined considering the following truck dimensions:

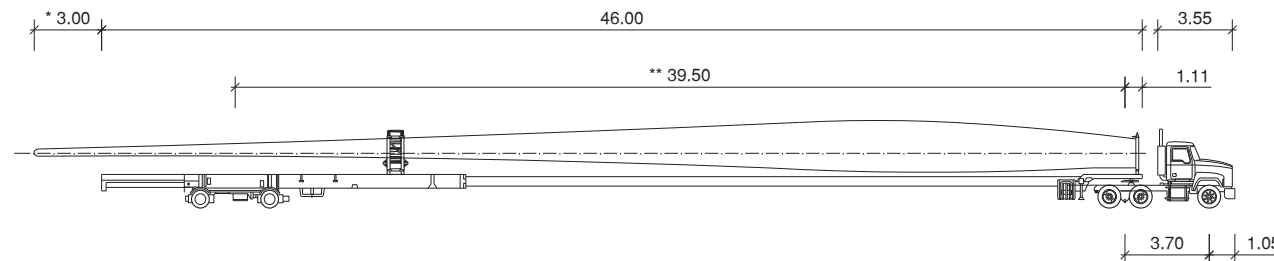

*The blade overhang requires an additional area to be cleared and free of obstacles outside the bend. The width of this additional area will be equal to the blade overhang. This additional area will be parallel to the road extra-widening.

**The distance between the axels requires an additional area to be cleared and free of obstacles inside the bend. This additional area will change depending of the truck and the bending radius and should be checked case-by-case.

-Different dimensions will lead to substantially different results.
-All units provided are in meters.

DESIGN REQUIREMENTS	
Minimum vertical curve parameter	$K_v = L / i_1 - i_2 = 350$
Maximum slope on gravel road	9%
Maximum slope on concrete road	14%
Minimum radius	45m
Min. straight length before/after the bend *	75m
* Additional bend wides provided in this drawing, will not be valid if this minimum straight length are not respected.	

60° BEND WIDENING - 5 METERS WIDE ROAD											
Radius	External					Internal					
	A	B	C	D	E	F	G	H	I	J	K
45m	-	-	0,6	1,2	1,4	-	-	0,6	-	-	-
50m	-	-	0,4	1,0	1,2	-	-	0,4	-	-	-
55m	-	-	-	0,6	0,8	-	-	-	-	-	-

60° Bend widening diagram:

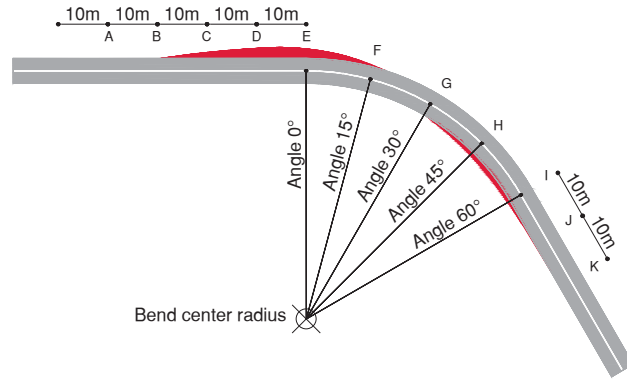

60° BEND WIDENING - 6 METERS WIDE ROAD											
Radius	External					Internal					
	A	B	C	D	E	F	G	H	I	J	K
45m	-	-	-	0,2	0,4	-	-	-	-	-	-
50m	-	-	-	-	0,2	-	-	-	-	-	-
55m	-	-	-	-	-	-	-	-	-	-	-

60° BEND WIDENING - 6.5 METERS WIDE ROAD											
Radius	External					Internal					
	A	B	C	D	E	F	G	H	I	J	K
45m	-	-	-	-	-	-	-	-	-	-	-
50m	-	-	-	-	-	-	-	-	-	-	-
55m	-	-	-	-	-	-	-	-	-	-	-

90° BEND WIDENING - 5 METERS WIDE ROAD													
Radius	External						Internal						
	A	B	C	D	E	F	G	H	I	J	K	L	M
45m	-	-	0,6	1,0	1,0	0,6	0,2	-	0,4	0,8	0,4	-	-
50m	-	-	0,2	0,8	0,8	0,2	-	-	-	0,6	0,2	-	-
55m	-	-	-	0,6	0,4	0,2	-	-	-	-	0,2	-	-

90° Bend widening diagram:

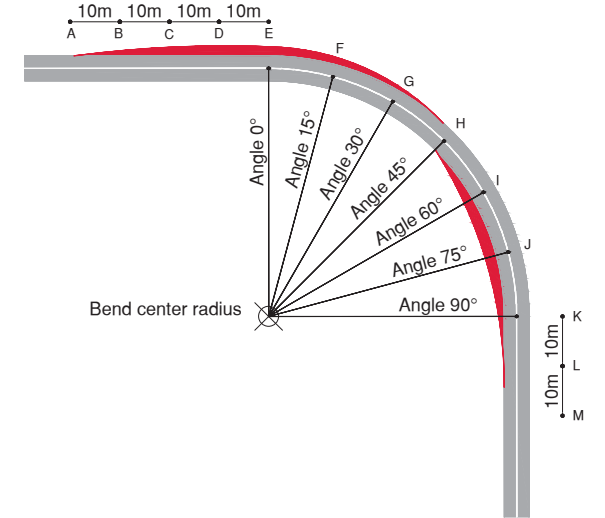

90° BEND WIDENING - 6 METERS WIDE ROAD													
Radius	External						Internal						
	A	B	C	D	E	F	G	H	I	J	K	L	M
45m	-	-	-	-	-	-	-	-	-	0,2	-	-	-
50m	-	-	-	-	-	-	-	-	-	-	-	-	-
55m	-	-	-	-	-	-	-	-	-	-	-	-	-

90° BEND WIDENING - 6.5 METERS WIDE ROAD													
Radius	External						Internal						
	A	B	C	D	E	F	G	H	I	J	K	L	M
45m	-	-	-	-	-	-	-	-	-	-	-	-	-
50m	-	-	-	-	-	-	-	-	-	-	-	-	-
55m	-	-	-	-	-	-	-	-	-	-	-	-	-

120° BEND WIDENING - 5 METERS WIDE ROAD															
Radius	External							Internal							
	A	B	C	D	E	F	G	H	I	J	K	L	M	N	O
45m	-	-	0,8	1,6	1,4	1,0	0,6	0,6	0,4	-	0,2	0,6	0,6	-	-
50m	-	-	0,4	1,0	0,8	0,4	0,2	0,2	0,2	-	-	0,4	-	-	-
55m	-	-	0,2	0,6	0,2	-	-	-	-	-	-	0,2	-	-	-

120° Bend widening diagram:

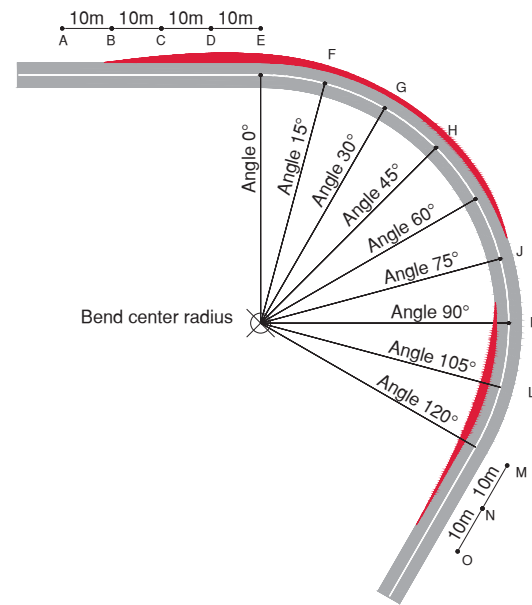

150° BEND WIDENING - 5 METERS WIDE ROAD																	
Radius	External									Internal							
	A	B	C	D	E	F	G	H	I	J	K	L	M	N	O	P	Q
45m	-	-	0,4	1,2	1,4	1,0	0,8	0,6	0,6	0,4	0,2	-	-	0,6	1,0	0,6	-
50m	-	-	0,2	0,8	1,0	0,6	0,6	0,4	0,4	0,2	0,2	-	-	-	0,6	0,2	-
55m	-	-	-	0,6	0,6	0,2	-	-	-	-	-	-	-	-	0,4	-	-

150° Bend widening diagram:

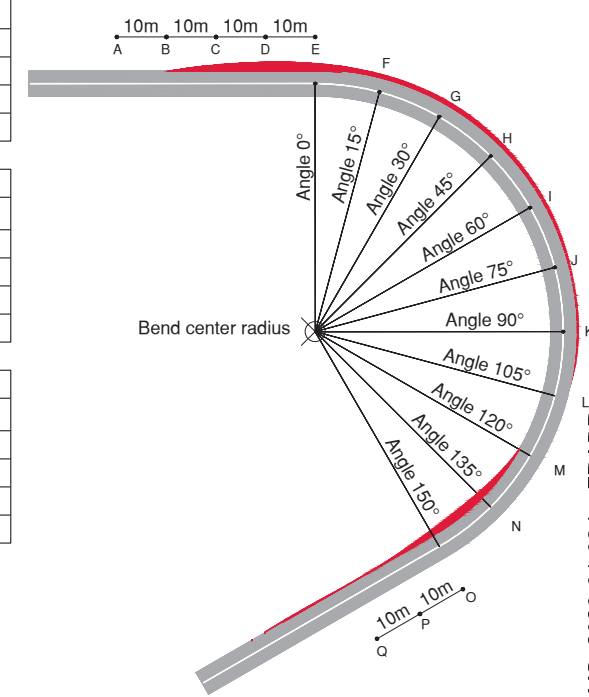

120° BEND WIDENING - 6 METERS WIDE ROAD															
Radius	External							Internal							
	A	B	C	D	E	F	G	H	I	J	K	L	M	N	O
45m	-	-	-	0,4	0,6	-	-	-	-	-	-	0,4	0,2	-	-
50m	-	-	-	-	-	-	-	-	-	-	-	-	-	-	-
55m	-	-	-	-	-	-	-	-	-	-	-	-	-	-	-

120° BEND WIDENING - 6.5 METERS WIDE ROAD															
Radius	External							Internal							
	A	B	C	D	E	F	G	H	I	J	K	L	M	N	O
45m	-	-	-	-	0,2	-	-	-	-	-	-	-	-	-	-
50m	-	-	-	-	-	-	-	-	-	-	-	-	-	-	-
55m	-	-	-	-	-	-	-	-	-	-	-	-	-	-	-

150° BEND WIDENING - 6 METERS WIDE ROAD																	
Radius	External									Internal							
	A	B	C	D	E	F	G	H	I	J	K	L	M	N	O	P	Q
45m	-	-	-	0,4	0,6	0,2	-	-	-	-	-	-	-	0,4	0,6	-	-
50m	-	-	-	-	-	-	-	-	-	-	-	-	-	-	-	-	-
55m	-	-	-	-	-	-	-	-	-	-	-	-	-	-	-	-	-

150° BEND WIDENING - 6.5 METERS WIDE ROAD																	
Radius	External									Internal							
	A	B	C	D	E	F	G	H	I	J	K	L	M	N	O	P	Q
45m	-	-	-	-	-	-	-	-	-	-	-	-	-	-	0,2	-	-
50m	-	-	-	-	-	-	-	-	-	-	-	-	-	-	-	-	-
55m	-	-	-	-	-	-	-	-	-	-	-	-	-	-	-	-	-

Design has been defined considering the following truck dimensions:

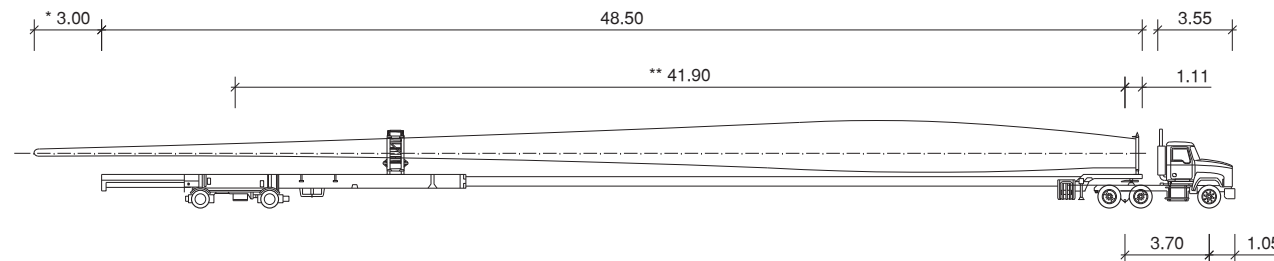

*The blade overhang requires an additional area to be cleared and free of obstacles outside the bend. The width of this additional area will be equal to the blade overhang. This additional area will be parallel to the road extra-widening.

**The distance between the axles requires an additional area to be cleared and free of obstacles inside the bend. This additional area will change depending of the truck and the bending radius and should be checked case-by-case.

-Different dimensions will lead to substantially different results.
-All units provided are in meters.

DESIGN REQUIREMENTS	
Minimum vertical curve parameter	$K_v = L / i_1 - i_2 = 400$
Maximum slope on gravel road	9%
Maximum slope on concrete road	14%
Minimum radius	45m
Min. straight length before/after the bend *	80m
* Additional bend widens provided in this drawing, will not be valid if this minimum straight length are not respected.	

60° BEND WIDENING - 5 METERS WIDE ROAD											
Radius	External					Internal					
	A	B	C	D	E	F	G	H	I	J	K
45m	-	-	1,0	1,6	1,8	0,2	0,2	1,0	0,2	-	-
50m	-	-	0,6	1,4	1,6	-	-	0,6	-	-	-
55m	-	-	-	0,8	1,0	-	-	0,2	-	-	-

60° Bend widening diagram:

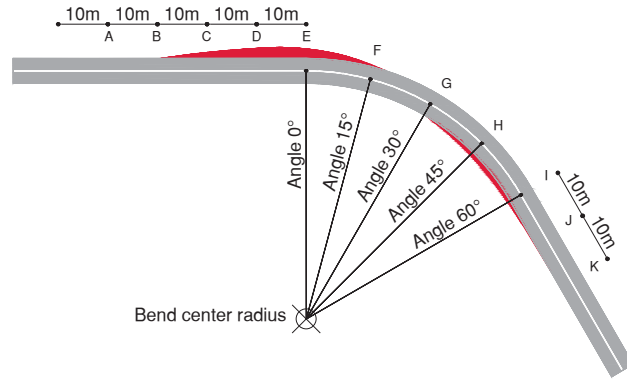

90° BEND WIDENING - 5 METERS WIDE ROAD													
Radius	External						Internal						
	A	B	C	D	E	F	G	H	I	J	K	L	M
45m	-	-	0,8	1,4	1,4	0,8	0,4	-	0,6	1,2	0,6	-	-
50m	-	-	0,4	1,0	1,0	0,4	-	-	-	0,8	0,4	-	-
55m	-	-	-	0,8	0,6	0,4	-	-	-	-	0,4	-	-

90° Bend widening diagram:

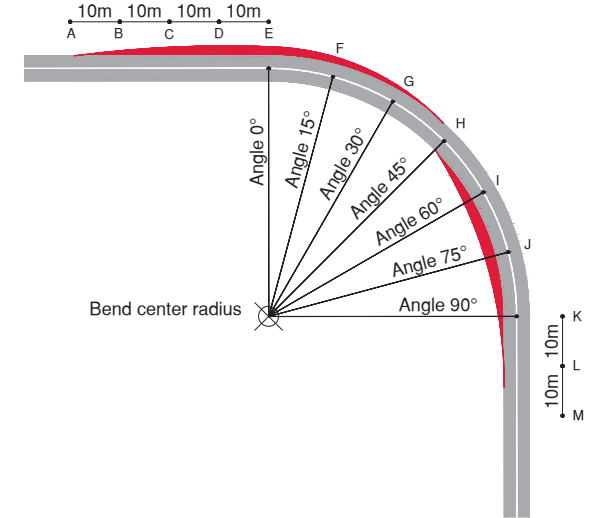

60° BEND WIDENING - 6 METERS WIDE ROAD											
Radius	External					Internal					
	A	B	C	D	E	F	G	H	I	J	K
45m	-	-	-	0,4	0,6	-	-	-	-	-	-
50m	-	-	-	0,2	0,4	-	-	-	-	-	-
55m	-	-	-	-	-	-	-	-	-	-	-

90° BEND WIDENING - 6 METERS WIDE ROAD													
Radius	External						Internal						
	A	B	C	D	E	F	G	H	I	J	K	L	M
45m	-	-	-	0,2	0,2	-	-	-	-	0,4	-	-	-
50m	-	-	-	-	-	-	-	-	-	-	-	-	-
55m	-	-	-	-	-	-	-	-	-	-	-	-	-

60° BEND WIDENING - 6.5 METERS WIDE ROAD											
Radius	External					Internal					
	A	B	C	D	E	F	G	H	I	J	K
45m	-	-	-	-	-	-	-	-	-	-	-
50m	-	-	-	-	-	-	-	-	-	-	-
55m	-	-	-	-	-	-	-	-	-	-	-

90° BEND WIDENING - 6.5 METERS WIDE ROAD													
Radius	External						Internal						
	A	B	C	D	E	F	G	H	I	J	K	L	M
45m	-	-	-	-	-	-	-	-	-	-	-	-	-
50m	-	-	-	-	-	-	-	-	-	-	-	-	-
55m	-	-	-	-	-	-	-	-	-	-	-	-	-

120° BEND WIDENING - 5 METERS WIDE ROAD															
Radius	External							Internal							
	A	B	C	D	E	F	G	H	I	J	K	L	M	N	O
45m	-	-	1,2	2,0	1,8	1,4	0,8	0,8	0,6	-	0,4	0,8	0,8	-	-
50m	-	-	0,6	1,4	1,0	0,6	0,4	0,4	0,4	-	-	0,6	0,2	-	-
55m	-	-	0,4	0,8	0,4	0,2	-	-	-	-	-	0,4	0,2	-	-

120° Bend widening diagram:

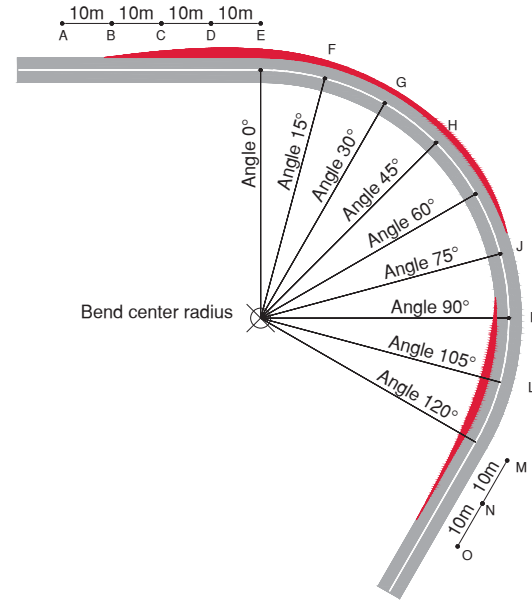

150° BEND WIDENING - 5 METERS WIDE ROAD																	
Radius	External								Internal								
	A	B	C	D	E	F	G	H	I	J	K	L	M	N	O	P	Q
45m	-	-	0,6	1,6	1,8	1,4	1,2	0,8	0,8	0,6	0,4	-	-	1,0	1,4	0,8	-
50m	-	-	0,4	1,2	1,4	0,8	0,8	0,6	0,6	0,4	0,4	-	-	-	1,0	0,4	-
55m	-	-	-	0,8	0,8	0,4	0,2	0,2	0,2	0,2	0,2	-	-	-	0,6	0,2	-

150° Bend widening diagram:

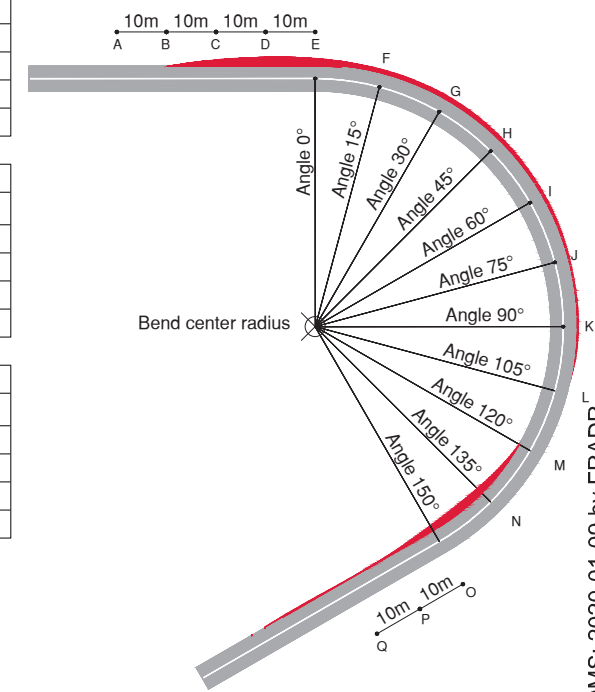

120° BEND WIDENING - 6 METERS WIDE ROAD														
Radius	External							Internal						
	A	B	C	D	E	F	G	H	I	J	K	L	M	N
45m	-	-	-	0,6	0,8	-	-	-	-	0,2	0,6	0,4	-	-
50m	-	-	-	0,2	-	-	-	-	-	-	-	-	-	-
55m	-	-	-	-	-	-	-	-	-	-	-	-	-	-

150° BEND WIDENING - 6 METERS WIDE ROAD																	
Radius	External								Internal								
	A	B	C	D	E	F	G	H	I	J	K	L	M	N	O	P	Q
45m	-	-	-	0,6	0,8	0,4	-	-	-	-	-	-	-	0,5	0,8	0,2	-
50m	-	-	-	0,2	0,2	-	-	-	-	-	-	-	-	-	0,2	-	-
55m	-	-	-	-	-	-	-	-	-	-	-	-	-	-	-	-	-

120° BEND WIDENING - 6.5 METERS WIDE ROAD														
Radius	External							Internal						
	A	B	C	D	E	F	G	H	I	J	K	L	M	N
45m	-	-	-	0,2	0,4	-	-	-	-	-	-	-	-	-
50m	-	-	-	-	-	-	-	-	-	-	-	-	-	-
55m	-	-	-	-	-	-	-	-	-	-	-	-	-	-

150° BEND WIDENING - 6.5 METERS WIDE ROAD																	
Radius	External								Internal								
	A	B	C	D	E	F	G	H	I	J	K	L	M	N	O	P	Q
45m	-	-	-	0,2	0,2	-	-	-	-	-	-	-	-	0,2	0,4	-	-
50m	-	-	-	-	-	-	-	-	-	-	-	-	-	-	-	-	-
55m	-	-	-	-	-	-	-	-	-	-	-	-	-	-	-	-	-

Design has been defined considering the following truck dimensions:

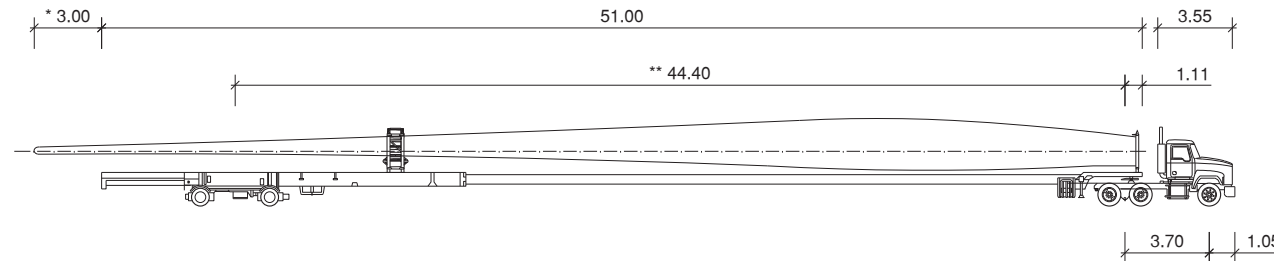

*The blade overhang requires an additional area to be cleared and free of obstacles outside the bend. The width of this additional area will be equal to the blade overhang. This additional area will be parallel to the road extra-widening.

**The distance between the axles requires an additional area to be cleared and free of obstacles inside the bend. This additional area will change depending of the truck and the bending radius and should be checked case-by-case.

-Different dimensions will lead to substantially different results.
-All units provided are in meters.

DESIGN REQUIREMENTS	
Minimum vertical curve parameter	$K_v = L / i_1 - i_2 = 400$
Maximum slope on gravel road	9%
Maximum slope on concrete road	14%
Minimum radius	45m
Min. straight length before/after the bend *	80m
* Additional bend widens provided in this drawing, will not be valid if this minimum straight length are not respected.	

60° BEND WIDENING - 5 METERS WIDE ROAD											
Radius	External						Internal				
	A	B	C	D	E	F	G	H	I	J	K
45m	-	0.1	1,1	1,8	1,9	0,4	0,4	1,1	0,3	-	-
50m	-	-	0,7	1,6	1,7	0,2	-	0,7	0,2	-	-
55m	-	-	0,2	0,9	1,1	0,1	-	0,3	0,1	-	-

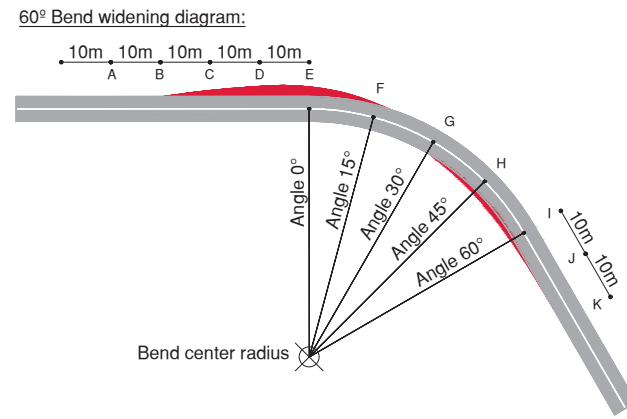

90° BEND WIDENING - 5 METERS WIDE ROAD													
Radius	External						Internal						
	A	B	C	D	E	F	G	H	I	J	K	L	M
45m	-	-	1,0	1,6	1,5	1,0	0,5	-	0,7	1,3	0,7	-	-
50m	-	-	0,6	1,2	1,1	0,6	0,2	-	-	0,9	0,6	-	-
55m	-	-	0,4	0,9	0,8	0,5	0,2	-	-	-	0,5	-	-

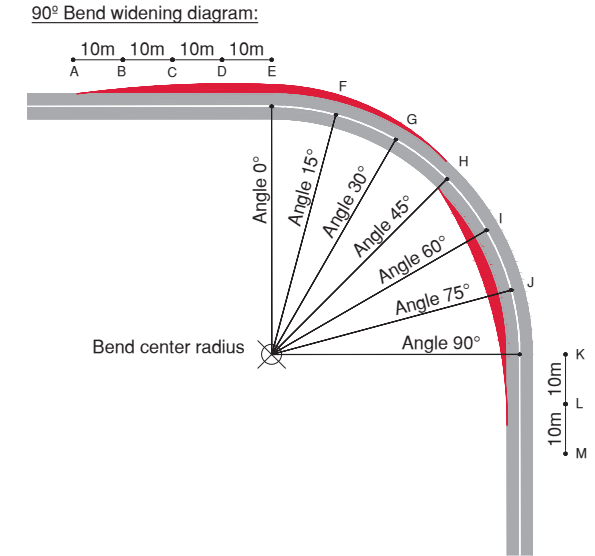

60° BEND WIDENING - 6 METERS WIDE ROAD											
Radius	External						Internal				
	A	B	C	D	E	F	G	H	I	J	K
45m	-	-	-	0,5	0,7	-	-	-	-	-	-
50m	-	-	-	0,3	0,6	-	-	-	-	-	-
55m	-	-	-	-	0,2	-	-	-	-	-	-

90° BEND WIDENING - 6 METERS WIDE ROAD													
Radius	External						Internal						
	A	B	C	D	E	F	G	H	I	J	K	L	M
45m	-	-	-	0,3	0,3	-	-	-	-	0,6	-	-	-
50m	-	-	-	0,2	0,2	-	-	-	-	0,2	-	-	-
55m	-	-	-	-	0,2	-	-	-	-	-	-	-	-

60° BEND WIDENING - 6.5 METERS WIDE ROAD											
Radius	External						Internal				
	A	B	C	D	E	F	G	H	I	J	K
45m	-	-	-	-	0,2	-	-	-	-	-	-
50m	-	-	-	-	0,2	-	-	-	-	-	-
55m	-	-	-	-	-	-	-	-	-	-	-

90° BEND WIDENING - 6.5 METERS WIDE ROAD													
Radius	External						Internal						
	A	B	C	D	E	F	G	H	I	J	K	L	M
45m	-	-	-	0,2	0,1	-	-	-	-	0,1	-	-	-
50m	-	-	-	-	-	-	-	-	-	-	-	-	-
55m	-	-	-	-	-	-	-	-	-	-	-	-	-

120° BEND WIDENING - 5 METERS WIDE ROAD															
Radius	External							Internal							
	A	B	C	D	E	F	G	H	I	J	K	L	M	N	O
45m	-	-	1,3	2,1	2,0	1,5	1,0	1,0	0,8	-	0,5	1,0	1,0	0,2	-
50m	-	-	0,8	1,6	1,2	0,8	0,5	0,5	0,5	-	0,2	0,8	0,4	-	-
55m	-	-	0,5	1,0	0,6	0,3	0,2	-	-	-	-	0,5	0,3	-	-

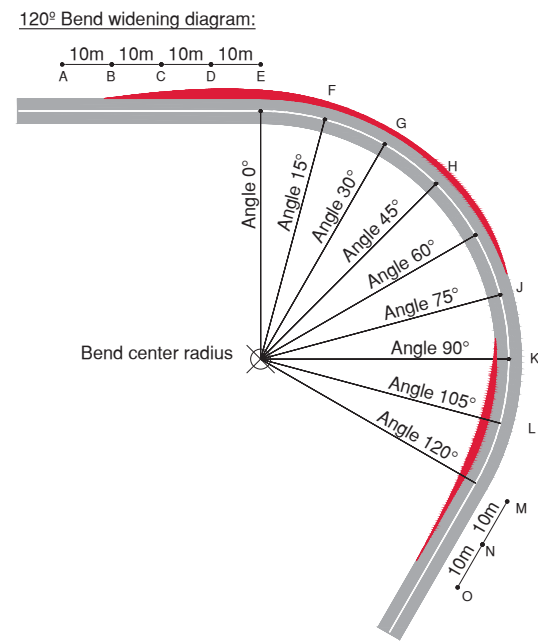

150° BEND WIDENING - 5 METERS WIDE ROAD																	
Radius	External									Internal							
	A	B	C	D	E	F	G	H	I	J	K	L	M	N	O	P	Q
45m	-	-	0,7	1,7	1,9	1,6	1,3	1,0	1,0	0,8	0,6	-	-	1,2	1,5	0,9	-
50m	-	-	0,5	1,4	1,5	1,0	0,9	0,8	0,7	0,6	0,6	-	-	0,2	1,1	0,6	-
55m	-	-	0,1	1,0	1,0	0,5	0,4	0,4	0,4	0,3	0,3	-	-	-	0,7	0,4	-

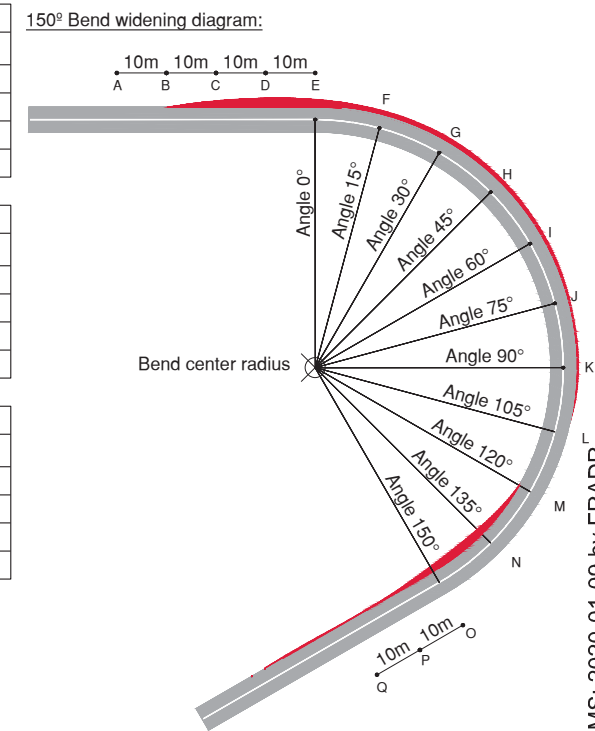

120° BEND WIDENING - 6 METERS WIDE ROAD															
Radius	External							Internal							
	A	B	C	D	E	F	G	H	I	J	K	L	M	N	O
45m	-	-	-	0,8	1,0	-	-	-	-	0,3	0,7	0,6	-	-	-
50m	-	-	-	0,3	0,2	-	-	-	-	-	-	-	-	-	-
55m	-	-	-	0,2	-	-	-	-	-	-	-	-	-	-	-

150° BEND WIDENING - 6 METERS WIDE ROAD																	
Radius	External									Internal							
	A	B	C	D	E	F	G	H	I	J	K	L	M	N	O	P	Q
45m	-	-	-	0,8	1,0	0,5	-	-	-	-	-	-	-	0,7	1,0	0,3	-
50m	-	-	-	0,4	0,3	-	-	-	-	-	-	-	-	0,4	-	-	-
55m	-	-	-	0,2	0,2	-	-	-	-	-	-	-	-	-	-	-	-

120° BEND WIDENING - 6.5 METERS WIDE ROAD															
Radius	External							Internal							
	A	B	C	D	E	F	G	H	I	J	K	L	M	N	O
45m	-	-	-	0,3	0,6	-	-	-	-	-	0,1	-	-	-	-
50m	-	-	-	-	-	-	-	-	-	-	-	-	-	-	-
55m	-	-	-	-	-	-	-	-	-	-	-	-	-	-	-

150° BEND WIDENING - 6.5 METERS WIDE ROAD																	
Radius	External									Internal							
	A	B	C	D	E	F	G	H	I	J	K	L	M	N	O	P	Q
45m	-	-	-	0,3	0,4	-	-	-	-	-	-	-	-	0,3	0,6	-	-
50m	-	-	-	-	-	-	-	-	-	-	-	-	-	-	-	-	-
55m	-	-	-	-	-	-	-	-	-	-	-	-	-	-	-	-	-

Design has been defined considering the following truck dimensions:

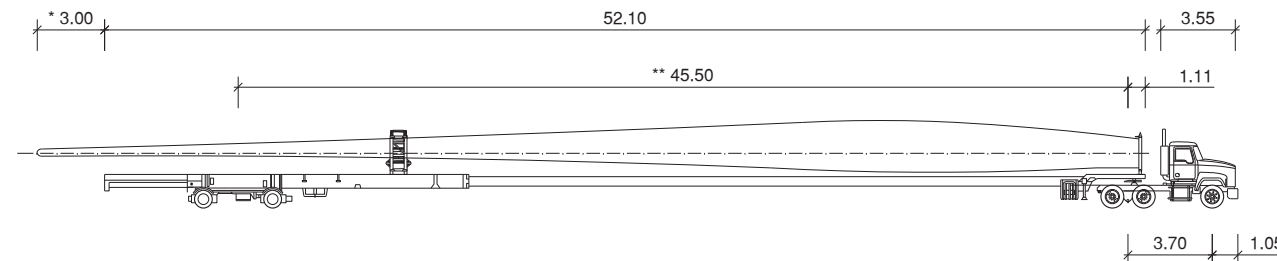

*The blade overhang requires an additional area to be cleared and free of obstacles outside the bend. The width of this additional area will be equal to the blade overhang. This additional area will be parallel to the road extra-widening.

**The distance between the axels requires an additional area to be cleared and free of obstacles inside the bend. This additional area will change depending of the truck and the bending radius and should be checked case-by-case.

-Different dimensions will lead to substantially different results.
-All units provided are in meters.

DESIGN REQUIREMENTS	
Minimum vertical curve parameter	$K_v = L / i_1 - i_2 = 400$
Maximum slope on gravel road	9%
Maximum slope on concrete road	14%
Minimum radius	45m
Min. straight length before/after the bend *	80m
* Additional bend wides provided in this drawing, will not be valid if this minimum straight length are not respected.	

60° BEND WIDENING - 5 METERS WIDE ROAD											
Radius	External						Internal				
	A	B	C	D	E	F	G	H	I	J	K
45m	-	0.3	1,2	2,0	1,8	0,4	0,6	1,6	0,8	-	-
50m	-	-	1,1	2,0	1,8	0,2	-	0,8	0,4	-	-
55m	-	-	0,4	1,4	1,6	0,2	-	0,6	0,4	-	-

60° Bend widening diagram:

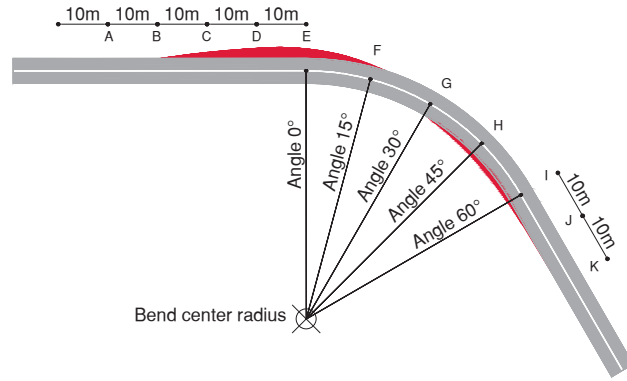

60° BEND WIDENING - 6 METERS WIDE ROAD											
Radius	External						Internal				
	A	B	C	D	E	F	G	H	I	J	K
45m	-	-	0,3	0,9	0,9	-	-	0,5	-	-	-
50m	-	-	-	0,7	0,8	-	-	0,2	-	-	-
55m	-	-	-	0,2	0,5	-	-	-	-	-	-

60° BEND WIDENING - 6.5 METERS WIDE ROAD											
Radius	External						Internal				
	A	B	C	D	E	F	G	H	I	J	K
45m	-	-	-	0,4	0,4	-	-	0,4	-	-	-
50m	-	-	-	0,2	0,3	-	-	-	-	-	-
55m	-	-	-	-	-	-	-	-	-	-	-

90° BEND WIDENING - 5 METERS WIDE ROAD													
Radius	External							Internal					
	A	B	C	D	E	F	G	H	I	J	K	L	M
45m	-	0.2	1.7	2.0	1.8	1.3	0.9	-	0.9	1.8	1.2	-	-
50m	-	-	0.9	1.8	1.6	1.2	0.8	-	0.2	1.0	0.6	-	-
55m	-	-	0.5	1.4	1.6	1.2	0.6	-	-	0.4	0.2	-	-

90° Bend widening diagram:

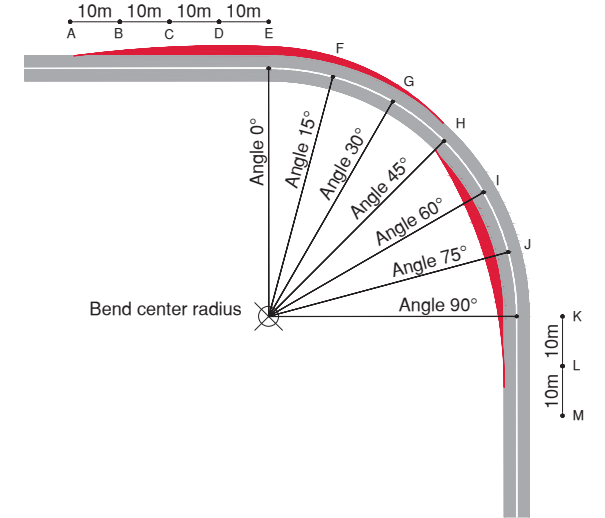

90° BEND WIDENING - 6 METERS WIDE ROAD													
Radius	External							Internal					
	A	B	C	D	E	F	G	H	I	J	K	L	M
45m	-	-	0.4	1.0	0.6	0.4	0.2	-	0.2	0.8	0.2	-	-
50m	-	-	-	0.8	0.6	0.4	0.2	-	-	0.2	-	-	-
55m	-	-	-	0.6	0.6	0.4	-	-	-	-	-	-	-

90° BEND WIDENING - 6.5 METERS WIDE ROAD													
Radius	External							Internal					
	A	B	C	D	E	F	G	H	I	J	K	L	M
45m	-	-	-	0.4	0.2	-	-	-	-	0.5	-	-	-
50m	-	-	-	0.2	0.2	-	-	-	-	-	-	-	-
55m	-	-	-	-	0.2	-	-	-	-	-	-	-	-

120° BEND WIDENING - 5 METERS WIDE ROAD															
Radius	External							Internal							
	A	B	C	D	E	F	G	H	I	J	K	L	M	N	O
45m	-	0.4	1.6	2.4	2.0	1.2	0.7	0.5	0.4	-	1.0	1.8	1.4	0.4	-
50m	-	-	1.2	1.6	1.4	1.0	0.5	0.4	0.4	-	0.4	1.4	1.0	0.2	-
55m	-	-	0.4	1.2	1.4	0.9	0.5	0.4	0.2	-	-	0.6	0.2	-	-

120° Bend widening diagram:

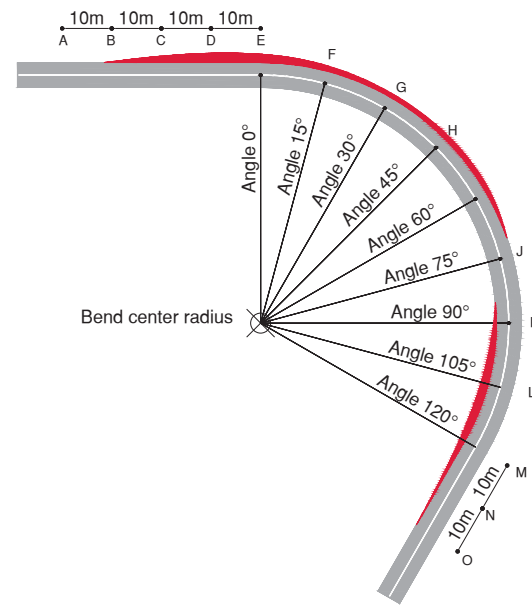

150° BEND WIDENING - 5 METERS WIDE ROAD																	
Radius	External									Internal							
	A	B	C	D	E	F	G	H	I	J	K	L	M	N	O	P	Q
45m	-	0.2	1.5	2.4	2.0	1.6	1.4	1.0	1.0	0.8	0.6	-	0.5	1.8	1.6	0.8	0.2
50m	-	-	1.2	1.6	1.6	1.0	0.9	0.9	0.8	0.5	0.4	-	-	1.2	1.0	-	-
55m	-	-	0.6	1.2	1.2	0.8	0.8	0.6	0.6	0.4	0.2	-	-	0.6	0.4	-	-

150° Bend widening diagram:

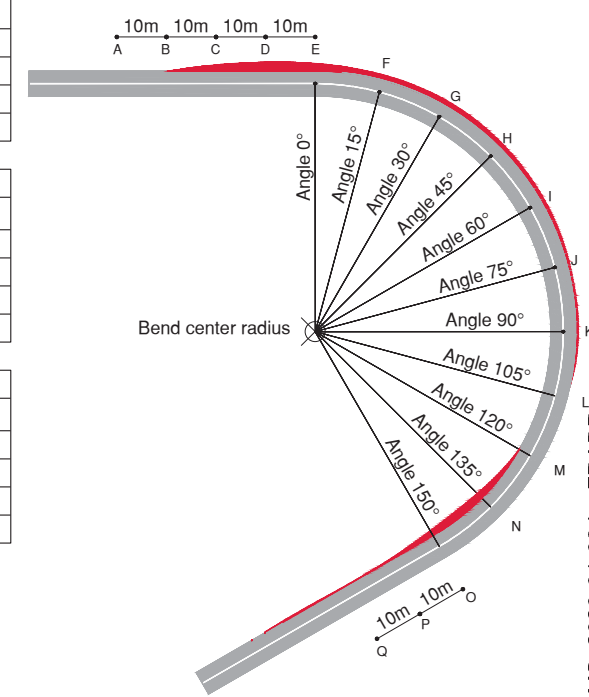

120° BEND WIDENING - 6 METERS WIDE ROAD															
Radius	External							Internal							
	A	B	C	D	E	F	G	H	I	J	K	L	M	N	O
45m	-	-	0.6	1.4	1.2	0.2	-	-	-	0.2	0.8	0.5	-	-	-
50m	-	-	-	0.6	0.6	-	-	-	-	-	0.7	0.2	-	-	-
55m	-	-	-	0.4	0.4	-	-	-	-	-	-	-	-	-	-

120° BEND WIDENING - 6.5 METERS WIDE ROAD															
Radius	External							Internal							
	A	B	C	D	E	F	G	H	I	J	K	L	M	N	O
45m	-	-	0.2	0.8	0.6	-	-	-	-	-	0.5	-	-	-	-
50m	-	-	-	-	-	-	-	-	-	-	-	-	-	-	-
55m	-	-	-	-	-	-	-	-	-	-	-	-	-	-	-

150° BEND WIDENING - 6 METERS WIDE ROAD																	
Radius	External									Internal							
	A	B	C	D	E	F	G	H	I	J	K	L	M	N	O	P	Q
45m	-	-	0.2	0.9	0.8	0.2	-	-	-	-	-	-	-	0.9	0.6	-	-
50m	-	-	-	0.6	0.4	-	-	-	-	-	-	-	-	0.3	-	-	-
55m	-	-	-	0.2	0.2	-	-	-	-	-	-	-	-	-	-	-	-

150° BEND WIDENING - 6.5 METERS WIDE ROAD																	
Radius	External									Internal							
	A	B	C	D	E	F	G	H	I	J	K	L	M	N	O	P	Q
45m	-	-	-	0.5	0.4	-	-	-	-	-	-	-	-	0.7	0.4	-	-
50m	-	-	-	0.2	-	-	-	-	-	-	-	-	-	-	-	-	-
55m	-	-	-	-	-	-	-	-	-	-	-	-	-	-	-	-	-

Design has been defined considering the following truck dimensions:

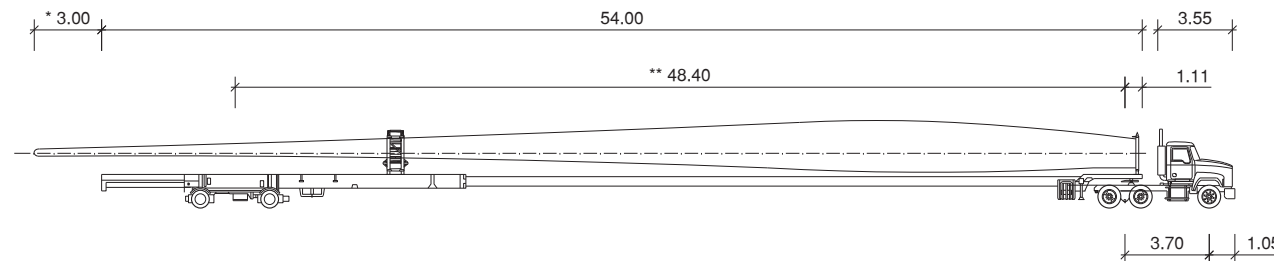

*The blade overhang requires an additional area to be cleared and free of obstacles outside the bend. The width of this additional area will be equal to the blade overhang. This additional area will be parallel to the road extra-widening.

**The distance between the axels requires an additional area to be cleared and free of obstacles inside the bend. This additional area will change depending of the truck and the bending radius and should be checked case-by-case.

-Different dimensions will lead to substantially different results.
-All units provided are in meters.

DESIGN REQUIREMENTS	
Minimum vertical curve parameter	$K_v = L / i_1 - i_2 = 400$
Maximum slope on gravel road	9%
Maximum slope on concrete road	14%
Minimum radius	45m
Min. straight length before/after the bend *	85m
* Additional bend wides provided in this drawing, will not be valid if this minimum straight length are not respected.	

60° BEND WIDENING - 5 METERS WIDE ROAD												
Radius	External						Internal					
	A	B	C	D	E	F	G	H	I	J	K	
45m	-	0.4	1.4	2.0	1.9	0.5	0.7	1.6	0.9	-	-	
50m	-	-	1.2	2.0	1.9	0.3	-	0.8	0.5	-	-	
55m	-	-	0.5	1.4	1.8	0.3	-	0.7	0.4	-	-	

60° Bend widening diagram:

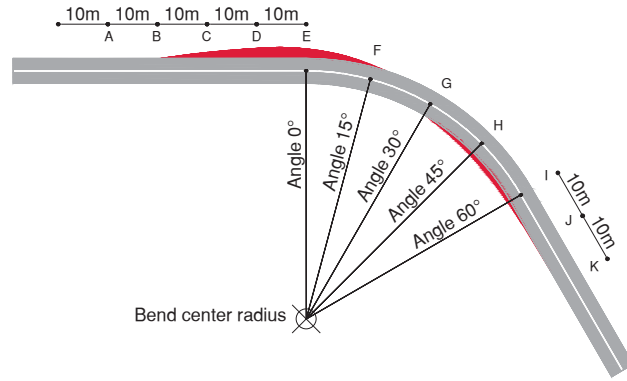

90° BEND WIDENING - 5 METERS WIDE ROAD												
Radius	External						Internal					
	A	B	C	D	E	F	G	H	I	J	K	
45m	-	0.3	1.8	2.2	1.8	1.4	1.0	-	1.0	1.9	1.3	
50m	-	-	1.0	1.9	1.7	1.3	0.8	-	0.3	1.1	0.7	
55m	-	-	0.6	1.6	1.7	1.2	0.7	-	-	0.5	0.3	

90° Bend widening diagram:

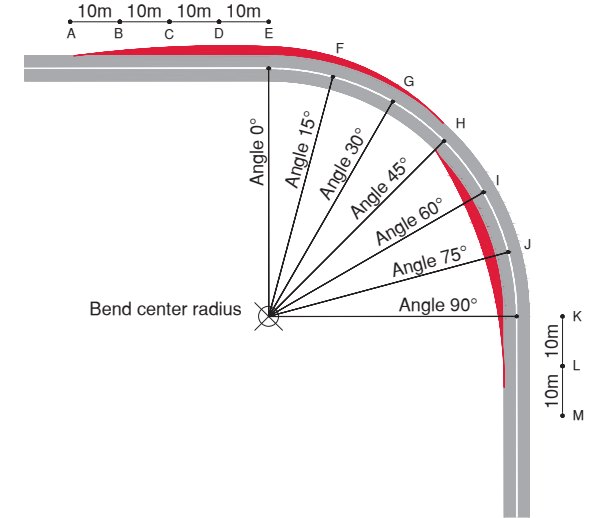

60° BEND WIDENING - 6 METERS WIDE ROAD												
Radius	External						Internal					
	A	B	C	D	E	F	G	H	I	J	K	
45m	-	-	0.3	1.0	1.0	-	-	0.6	-	-	-	
50m	-	-	-	0.8	0.9	-	-	0.2	-	-	-	
55m	-	-	-	0.2	0.6	-	-	-	-	-	-	

90° BEND WIDENING - 6 METERS WIDE ROAD												
Radius	External						Internal					
	A	B	C	D	E	F	G	H	I	J	K	
45m	-	-	0.5	1.1	0.8	0.4	0.3	-	0.2	1.0	0.3	
50m	-	-	-	0.8	0.7	0.5	0.2	-	-	0.3	-	
55m	-	-	-	0.6	0.7	0.5	-	-	-	-	-	

60° BEND WIDENING - 6.5 METERS WIDE ROAD												
Radius	External						Internal					
	A	B	C	D	E	F	G	H	I	J	K	
45m	-	-	-	0.5	0.4	-	-	0.5	-	-	-	
50m	-	-	-	0.3	0.3	-	-	-	-	-	-	
55m	-	-	-	-	-	-	-	-	-	-	-	

90° BEND WIDENING - 6.5 METERS WIDE ROAD												
Radius	External						Internal					
	A	B	C	D	E	F	G	H	I	J	K	
45m	-	-	-	0.6	0.3	-	-	-	-	0.6	-	
50m	-	-	-	0.3	0.2	-	-	-	-	-	-	
55m	-	-	-	-	0.2	-	-	-	-	-	-	

120° BEND WIDENING - 5 METERS WIDE ROAD															
Radius	External							Internal							
	A	B	C	D	E	F	G	H	I	J	K	L	M	N	O
45m	-	0.5	1.7	2.5	2.1	1.2	0.8	0.6	0.4	-	1.1	2.0	1.5	0.4	-
50m	-	0.2	1.3	1.6	1.4	1.0	0.6	0.6	0.4	-	0.5	1.5	1.0	0.3	-
55m	-	-	0.4	1.4	1.5	1.0	0.6	0.5	0.4	-	-	0.6	0.3	-	-

120° Bend widening diagram:

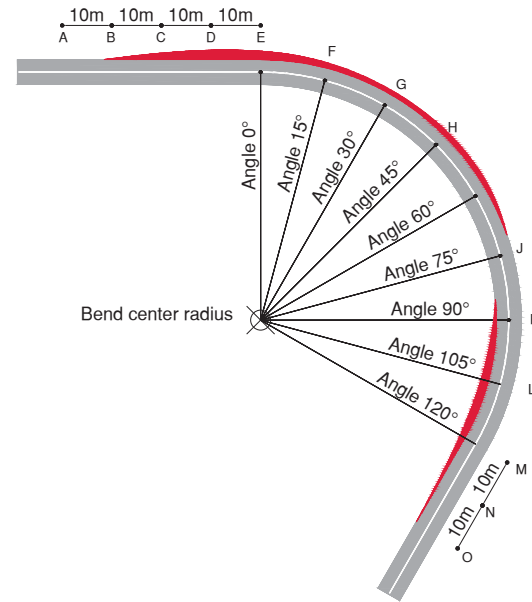

150° BEND WIDENING - 5 METERS WIDE ROAD																	
Radius	External									Internal							
	A	B	C	D	E	F	G	H	I	J	K	L	M	N	O	P	Q
45m	-	0.3	1.6	2.4	2.1	1.7	1.4	1.1	1.1	1.0	0.7	-	0.6	1.9	1.7	0.8	0.3
50m	-	-	1.3	1.8	1.6	1.0	1.0	1.0	0.8	0.6	0.5	-	0.1	1.3	1.1	0.2	-
55m	-	-	0.7	1.4	1.3	1.0	1.0	0.7	0.6	0.5	0.3	-	-	0.7	0.4	-	-

150° Bend widening diagram:

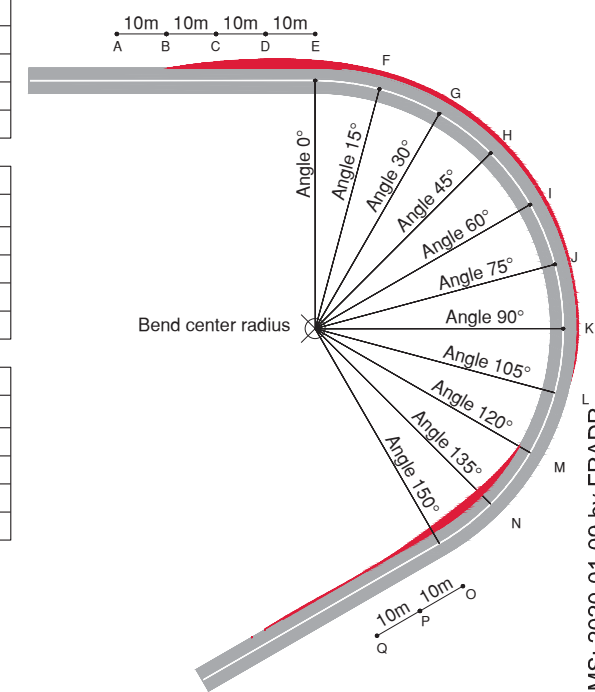

120° BEND WIDENING - 6 METERS WIDE ROAD															
Radius	External							Internal							
	A	B	C	D	E	F	G	H	I	J	K	L	M	N	O
45m	-	-	0.7	1.5	1.3	0.3	-	-	-	0.2	1.0	0.6	-	-	-
50m	-	-	-	0.7	0.7	-	-	-	-	-	0.8	0.3	-	-	-
55m	-	-	-	0.4	0.5	-	-	-	-	-	-	-	-	-	-

150° BEND WIDENING - 6 METERS WIDE ROAD																	
Radius	External									Internal							
	A	B	C	D	E	F	G	H	I	J	K	L	M	N	O	P	Q
45m	-	-	0.3	1.0	0.8	0.3	0.1	-	-	-	-	-	-	1.0	0.7	-	-
50m	-	-	-	0.7	0.4	-	-	-	-	-	-	-	-	0.4	-	-	-
55m	-	-	-	0.3	0.2	-	-	-	-	-	-	-	-	-	-	-	-

120° BEND WIDENING - 6.5 METERS WIDE ROAD															
Radius	External							Internal							
	A	B	C	D	E	F	G	H	I	J	K	L	M	N	O
45m	-	-	0.2	0.9	0.6	-	-	-	-	-	0.7	-	-	-	-
50m	-	-	-	-	-	-	-	-	-	-	-	-	-	-	-
55m	-	-	-	-	-	-	-	-	-	-	-	-	-	-	-

150° BEND WIDENING - 6.5 METERS WIDE ROAD																	
Radius	External									Internal							
	A	B	C	D	E	F	G	H	I	J	K	L	M	N	O	P	Q
45m	-	-	-	0.6	0.4	-	-	-	-	-	-	-	-	0.8	0.5	-	-
50m	-	-	-	0.2	0.1	-	-	-	-	-	-	-	-	-	-	-	-
55m	-	-	-	-	-	-	-	-	-	-	-	-	-	-	-	-	-

Design has been defined considering the following truck dimensions:

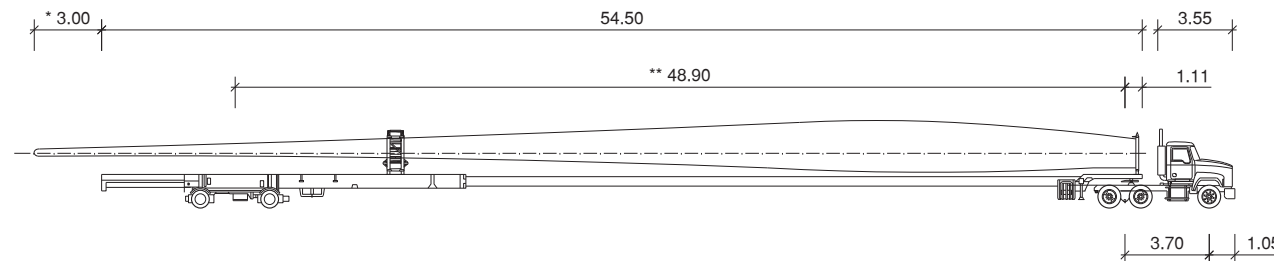

*The blade overhang requires an additional area to be cleared and free of obstacles outside the bend. The width of this additional area will be equal to the blade overhang. This additional area will be parallel to the road extra-widening.

**The distance between the axels requires an additional area to be cleared and free of obstacles inside the bend. This additional area will change depending of the truck and the bending radius and should be checked case-by-case.

-Different dimensions will lead to substantially different results.
-All units provided are in meters.

DESIGN REQUIREMENTS	
Minimum vertical curve parameter	$K_v = L / i_1 - i_2 = 400$
Maximum slope on gravel road	9%
Maximum slope on concrete road	14%
Minimum radius	45m
Min. straight length before/after the bend *	85m
* Additional bend wides provided in this drawing, will not be valid if this minimum straight length are not respected.	

60° BEND WIDENING - 5 METERS WIDE ROAD											
Radius	External						Internal				
	A	B	C	D	E	F	G	H	I	J	K
50m	-	0.6	1.8	2.2	2.0	0.2	0.2	0.4	0.6	0.2	-
55m	-	0.4	1.2	1.8	1.4	0.2	-	0.4	0.4	-	-
60m	-	0.2	0.8	1.2	0.8	-	-	0.2	-	-	-

60° Bend widening diagram:

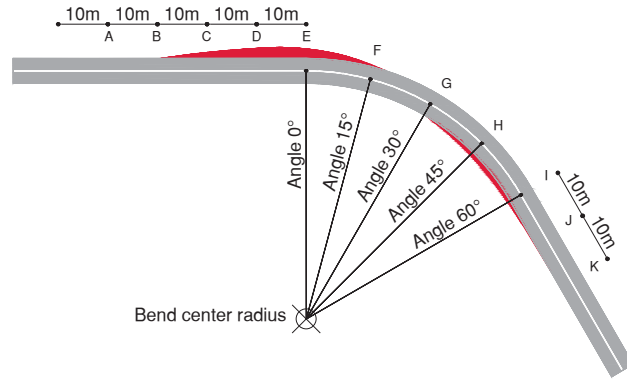

90° BEND WIDENING - 5 METERS WIDE ROAD													
Radius	External						Internal						
	A	B	C	D	E	F	G	H	I	J	K	L	M
50m	-	0.6	1.8	2.2	2.0	1.6	1.0	-	0.2	1.0	0.8	0.2	-
55m	-	0.4	1.4	2.0	1.6	0.8	0.4	-	-	0.8	0.4	-	-
60m	-	0.2	0.8	1.6	1.2	0.4	0.2	-	-	0.5	-	-	-

90° Bend widening diagram:

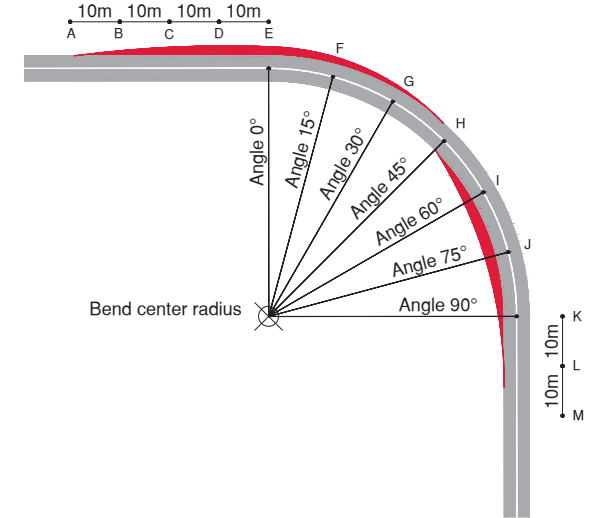

60° BEND WIDENING - 6 METERS WIDE ROAD											
Radius	External						Internal				
	A	B	C	D	E	F	G	H	I	J	K
50m	-	-	1.0	1.4	1.2	-	-	-	-	-	-
55m	-	-	0.6	1.0	0.8	-	-	-	-	-	-
60m	-	-	0.2	0.8	0.6	-	-	-	-	-	-

90° BEND WIDENING - 6 METERS WIDE ROAD													
Radius	External						Internal						
	A	B	C	D	E	F	G	H	I	J	K	L	M
50m	-	-	0.8	1.4	1.2	0.8	0.4	-	-	0.4	-	-	-
55m	-	-	0.6	1.0	0.8	0.2	0.2	-	-	-	-	-	-
60m	-	-	0.4	0.8	0.6	0.2	-	-	-	-	-	-	-

60° BEND WIDENING - 6.5 METERS WIDE ROAD											
Radius	External						Internal				
	A	B	C	D	E	F	G	H	I	J	K
50m	-	-	0.6	1.0	0.8	-	-	-	-	-	-
55m	-	-	0.2	0.6	0.4	-	-	-	-	-	-
60m	-	-	-	0.4	0.2	-	-	-	-	-	-

90° BEND WIDENING - 6.5 METERS WIDE ROAD													
Radius	External						Internal						
	A	B	C	D	E	F	G	H	I	J	K	L	M
50m	-	-	0.6	0.8	0.6	0.2	-	-	-	-	-	-	-
55m	-	-	0.4	0.6	0.4	-	-	-	-	-	-	-	-
60m	-	-	-	0.4	0.4	-	-	-	-	-	-	-	-

120° BEND WIDENING - 5 METERS WIDE ROAD															
Radius	External							Internal							
	A	B	C	D	E	F	G	H	I	J	K	L	M	N	O
50m	-	0.8	2.0	2.4	1.8	1.2	0.6	0.4	-	-	0.8	1.6	1.0	0.2	-
55m	-	0.4	1.4	2.0	1.6	0.6	0.2	-	-	-	0.4	1.0	0.2	-	-
60m	-	0.2	1.0	1.6	1.0	0.4	-	-	-	-	-	0.6	-	-	-

120° Bend widening diagram:

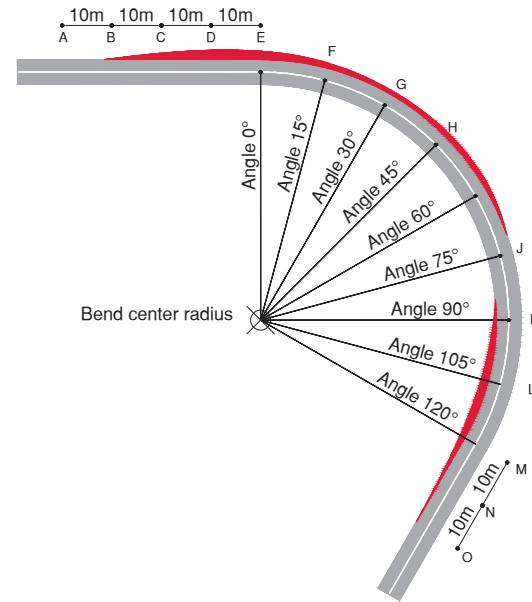

150° BEND WIDENING - 5 METERS WIDE ROAD																	
Radius	External									Internal							
	A	B	C	D	E	F	G	H	I	J	K	L	M	N	O	P	Q
50m	-	0.8	2.0	2.6	2.0	1.0	0.6	0.2	0.2	-	-	-	0.8	1.2	0.6	0.2	-
55m	-	0.6	1.6	2.2	1.6	0.6	0.2	0.2	-	-	-	-	0.4	0.8	0.4	-	-
60m	-	0.2	1.2	1.4	1.0	0.4	0.2	-	-	-	-	-	-	0.4	-	-	-

150° Bend widening diagram:

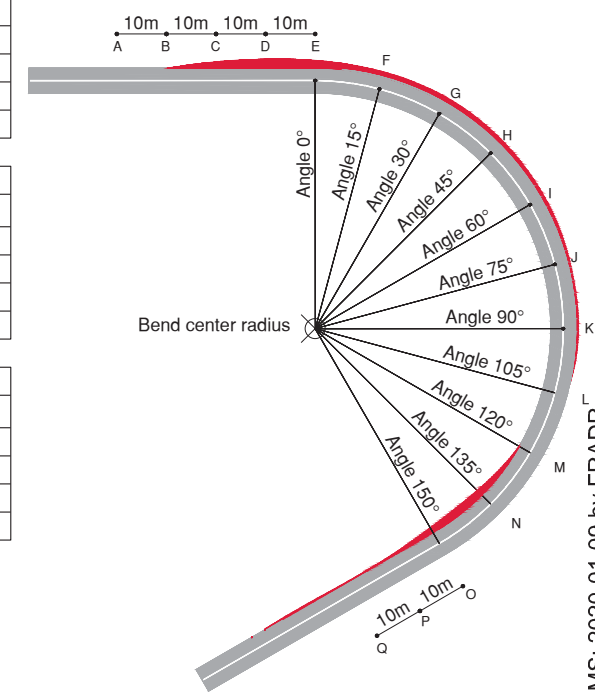

120° BEND WIDENING - 6 METERS WIDE ROAD														
Radius	External							Internal						
	A	B	C	D	E	F	G	H	I	J	K	L	M	N
50m	-	-	2.0	1.8	1.6	0.6	-	-	-	0.4	0.4	0.2	-	-
55m	-	-	0.8	1.4	0.8	0.2	-	-	-	-	0.2	-	-	-
60m	-	-	0.6	1.0	0.4	-	-	-	-	-	-	-	-	-

150° BEND WIDENING - 6 METERS WIDE ROAD																
Radius	External									Internal						
	A	B	C	D	E	F	G	H	I	J	K	L	M	N	O	P
50m	-	-	1.0	1.6	1.6	0.8	0.2	-	-	-	-	0.4	0.8	-	-	-
55m	-	-	0.6	1.0	0.8	0.2	-	-	-	-	-	-	-	-	-	-
60m	-	-	0.4	0.8	0.4	-	-	-	-	-	-	-	-	-	-	-

120° BEND WIDENING - 6.5 METERS WIDE ROAD														
Radius	External							Internal						
	A	B	C	D	E	F	G	H	I	J	K	L	M	N
50m	-	-	0.6	1.0	0.8	-	-	-	-	-	-	-	-	-
55m	-	-	0.4	0.8	0.6	-	-	-	-	-	-	-	-	-
60m	-	-	0.2	0.4	-	-	-	-	-	-	-	-	-	-

150° BEND WIDENING - 6.5 METERS WIDE ROAD																
Radius	External									Internal						
	A	B	C	D	E	F	G	H	I	J	K	L	M	N	O	P
50m	-	-	0.6	1.4	0.8	0.2	-	-	-	-	-	-	0.6	-	-	-
55m	-	-	0.2	0.8	0.4	-	-	-	-	-	-	-	-	-	-	-
60m	-	-	-	0.4	-	-	-	-	-	-	-	-	-	-	-	-

Design has been defined considering the following truck dimensions:

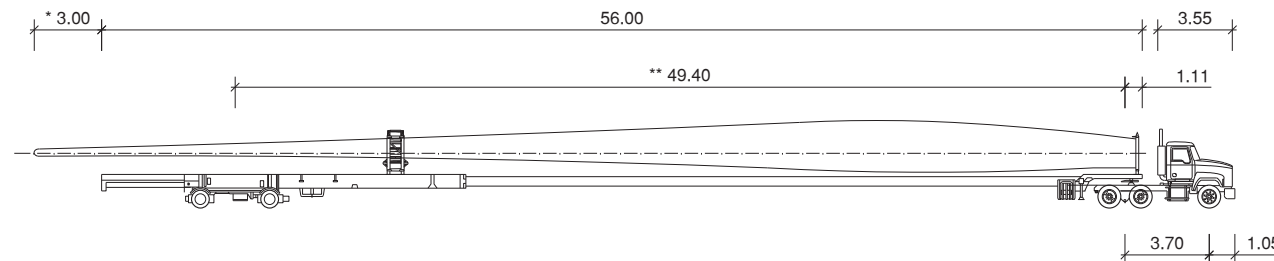

*The blade overhang requires an additional area to be cleared and free of obstacles outside the bend. The width of this additional area will be equal to the blade overhang. This additional area will be parallel to the road extra-widening.

**The distance between the axels requires an additional area to be cleared and free of obstacles inside the bend. This additional area will change depending of the truck and the bending radius and should be checked case-by-case.

-Different dimensions will lead to substantially different results.
-All units provided are in meters.

DESIGN REQUIREMENTS	
Minimum vertical curve parameter	$K_v = L / i_1 - i_2 = 450$
Maximum slope on gravel road	9%
Maximum slope on concrete road	14%
Minimum radius	50m
Min. straight length before/after the bend *	90m
* Additional bend wides provided in this drawing, will not be valid if this minimum straight length are not respected.	

60° BEND WIDENING - 5 METERS WIDE ROAD											
Radius	External					Internal					
	A	B	C	D	E	F	G	H	I	J	K
50m	-	1.3	2.7	3.1	3.0	0.5	0.6	1.0	1.1	0.5	-
55m	-	1.1	2.1	2.8	2.3	0.5	-	1.0	0.8	0.3	-
60m	-	0.6	1.7	2.3	2.1	0.5	-	0.8	0.5	-	-

60° Bend widening diagram:

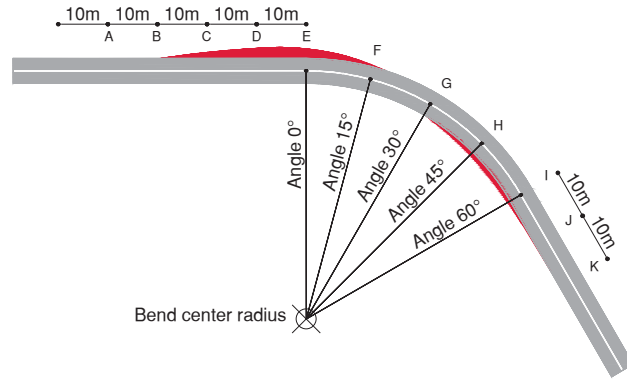

90° BEND WIDENING - 5 METERS WIDE ROAD													
Radius	External						Internal						
	A	B	C	D	E	F	G	H	I	J	K	L	M
50m	-	1.2	2.6	3.3	3.1	2.6	1.8	-	0.7	1.7	1.3	0.5	-
55m	-	1.0	2.2	3.0	2.4	1.5	1.1	-	0.7	1.5	0.9	0.2	-
60m	-	0.4	1.7	2.4	2.1	1.0	0.9	-	0.2	1.0	-	-	-

90° Bend widening diagram:

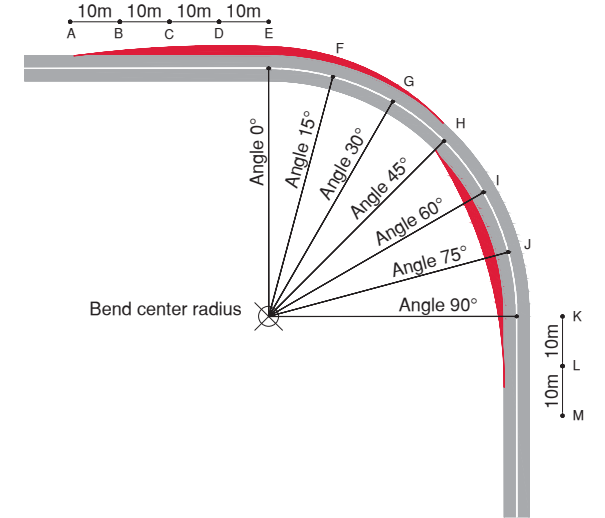

60° BEND WIDENING - 6 METERS WIDE ROAD											
Radius	External					Internal					
	A	B	C	D	E	F	G	H	I	J	K
50m	-	0.2	1.6	2.1	2.0	-	-	0.3	0.1	-	-
55m	-	0.1	1.2	1.5	1.3	-	-	0.3	-	-	-
60m	-	-	0.7	1.3	1.1	-	-	0.3	-	-	-

90° BEND WIDENING - 6 METERS WIDE ROAD													
Radius	External						Internal						
	A	B	C	D	E	F	G	H	I	J	K	L	M
50m	-	0.2	1.6	2.2	1.9	1.2	1.0	-	-	0.8	-	-	-
55m	-	-	1.3	1.8	1.4	0.6	0.6	-	-	-	-	-	-
60m	-	-	0.9	1.6	1.4	-	-	-	-	-	-	-	-

60° BEND WIDENING - 6.5 METERS WIDE ROAD											
Radius	External					Internal					
	A	B	C	D	E	F	G	H	I	J	K
50m	-	-	1.1	1.6	1.6	-	-	0.2	-	-	-
55m	-	-	0.7	1.0	0.8	-	-	0.1	-	-	-
60m	-	-	-	0.9	0.6	-	-	-	-	-	-

90° BEND WIDENING - 6.5 METERS WIDE ROAD													
Radius	External						Internal						
	A	B	C	D	E	F	G	H	I	J	K	L	M
50m	-	-	1.1	1.6	1.3	0.7	0.6	-	-	0.5	-	-	-
55m	-	-	0.8	1.2	0.9	0.2	-	-	-	-	-	-	-
60m	-	-	0.5	1.1	0.9	-	-	-	-	-	-	-	-

120° BEND WIDENING - 5 METERS WIDE ROAD															
Radius	External							Internal							
	A	B	C	D	E	F	G	H	I	J	K	L	M	N	O
50m	-	1.4	2.8	3.4	2.8	1.7	1.1	1.0	0.5	-	1.6	2.5	1.5	0.2	-
55m	-	1.0	2.2	2.9	2.3	1.0	0.7	0.5	0.4	-	1.1	1.8	0.4	-	-
60m	-	0.8	2.0	2.4	2.0	0.8	0.2	0.2	0.3	-	0.4	1.7	0.4	-	-

120° Bend widening diagram:

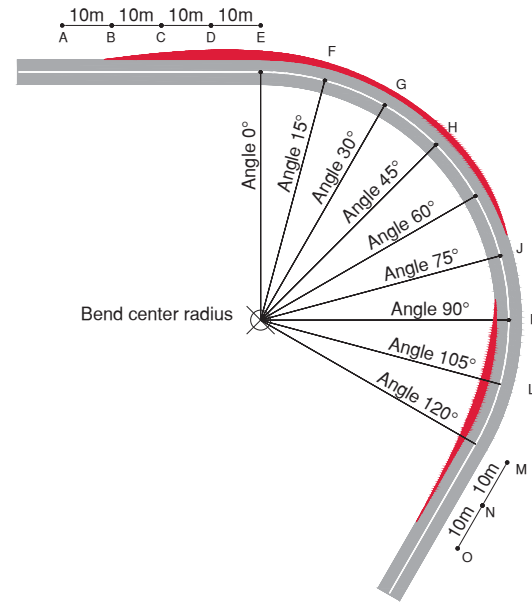

150° BEND WIDENING - 5 METERS WIDE ROAD																	
Radius	External									Internal							
	A	B	C	D	E	F	G	H	I	J	K	L	M	N	O	P	Q
50m	-	1.5	3.0	3.8	3.2	1.7	1.0	0.6	0.6	0.7	0.5	-	1.6	2.1	1.0	0.4	-
55m	-	0.9	2.2	3.0	2.6	1.4	0.5	0.3	0.3	0.5	0.4	-	0.9	1.7	0.8	-	-
60m	-	0.8	2.0	2.5	2.1	0.8	0.3	0.3	-	-	-	-	0.5	1.1	0.3	-	-

150° Bend widening diagram:

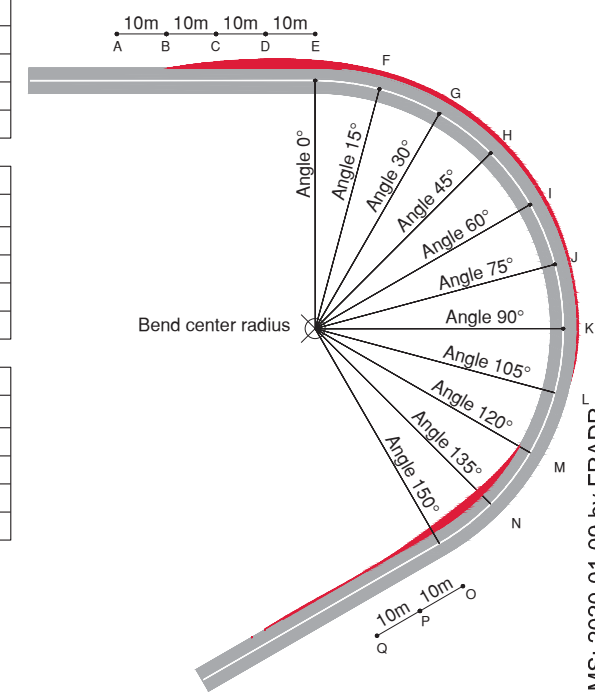

120° BEND WIDENING - 6 METERS WIDE ROAD															
Radius	External							Internal							
	A	B	C	D	E	F	G	H	I	J	K	L	M	N	O
50m	-	0.3	1.8	2.5	2.0	1.0	0.4	0.4	0.1	-	0.8	1.0	0.5	-	-
55m	-	-	1.2	2.0	1.7	0.5	0.2	0.2	-	-	-	0.1	0.5	-	-
60m	-	-	1.2	1.5	0.9	-	-	-	-	-	-	-	-	-	-

150° BEND WIDENING - 6 METERS WIDE ROAD																	
Radius	External									Internal							
	A	B	C	D	E	F	G	H	I	J	K	L	M	N	O	P	Q
50m	-	0.2	1.6	2.6	2.3	1.3	0.6	-	-	-	-	-	1.2	1.7	0.1	-	-
55m	-	-	1.3	1.9	1.5	0.5	0.3	-	-	-	-	-	0.3	0.2	-	-	-
60m	-	-	1.0	1.7	1.3	-	-	-	-	-	-	-	-	-	-	-	-

120° BEND WIDENING - 6.5 METERS WIDE ROAD															
Radius	External							Internal							
	A	B	C	D	E	F	G	H	I	J	K	L	M	N	O
50m	-	-	1.3	1.9	1.5	0.6	-	-	-	-	0.4	0.6	-	-	-
55m	-	-	0.7	1.4	1.1	0.2	-	-	-	-	0.2	-	-	-	-
60m	-	-	0.5	0.9	0.4	-	-	-	-	-	-	-	-	-	-

150° BEND WIDENING - 6.5 METERS WIDE ROAD																	
Radius	External									Internal							
	A	B	C	D	E	F	G	H	I	J	K	L	M	N	O	P	Q
50m	-	-	1.1	2.1	1.8	0.8	0.2	-	-	-	-	-	0.7	1.3	-	-	-
55m	-	-	0.8	1.3	1.0	0.2	-	-	-	-	-	-	-	-	-	-	-
60m	-	-	0.5	1.1	0.8	-	-	-	-	-	-	-	-	-	-	-	-

Design has been defined considering the following truck dimensions:

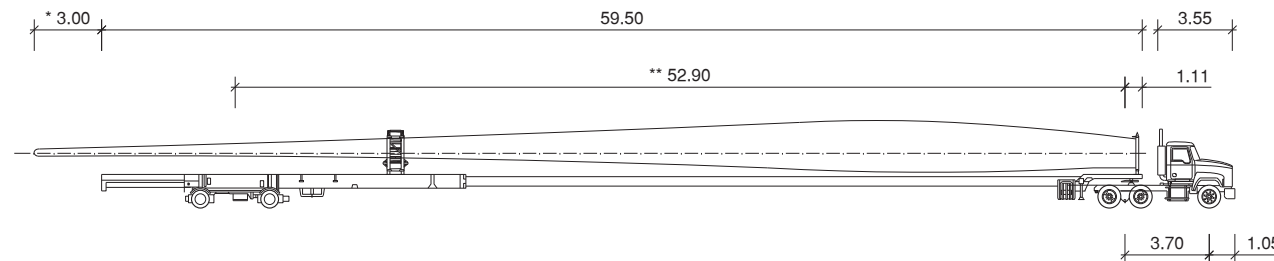

*The blade overhang requires an additional area to be cleared and free of obstacles outside the bend. The width of this additional area will be equal to the blade overhang. This additional area will be parallel to the road extra-widening.

**The distance between the axels requires an additional area to be cleared and free of obstacles inside the bend. This additional area will change depending of the truck and the bending radius and should be checked case-by-case.

-Different dimensions will lead to substantially different results.
-All units provided are in meters.

DESIGN REQUIREMENTS	
Minimum vertical curve parameter	$K_v = L / i_1 - i_2 = 450$
Maximum slope on gravel road	9%
Maximum slope on concrete road	14%
Minimum radius	50m
Min. straight length before/after the bend *	90m
* Additional bend wides provided in this drawing, will not be valid if this minimum straight length are not respected.	

60° BEND WIDENING - 5 METERS WIDE ROAD											
Radius	External						Internal				
	A	B	C	D	E	F	G	H	I	J	K
55m	0.2	1.9	3.2	3.7	3.1	0.7	0.8	2.4	1.2	0.9	0.5
60m	-	1.6	2.8	3.4	2.7	0.6	0.4	1.0	1.0	0.5	-
65m	-	1.4	2.4	3.2	2.4	0.6	-	0.8	0.8	0.3	-

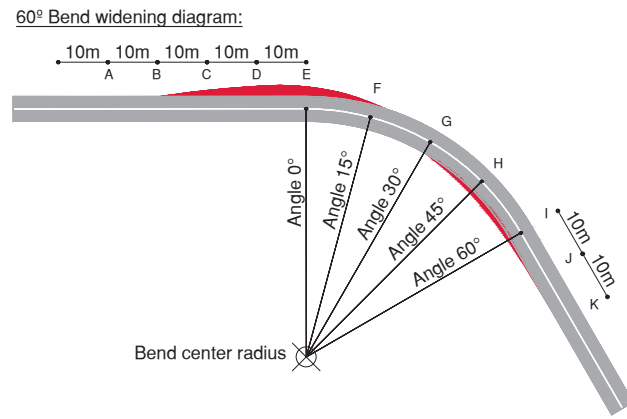

90° BEND WIDENING - 5 METERS WIDE ROAD													
Radius	External						Internal						
	A	B	C	D	E	F	G	H	I	J	K	L	M
55m	0.2	1.6	3.0	3.8	3.5	2.4	1.6	-	1.3	1.9	1.2	0.6	0.3
60m	0.2	1.6	2.4	3.0	2.7	1.6	1.0	-	1.2	1.9	1.1	0.2	-
65m	-	1.4	2.2	2.6	2.5	1.6	1.0	-	1.1	1.8	0.8	-	-

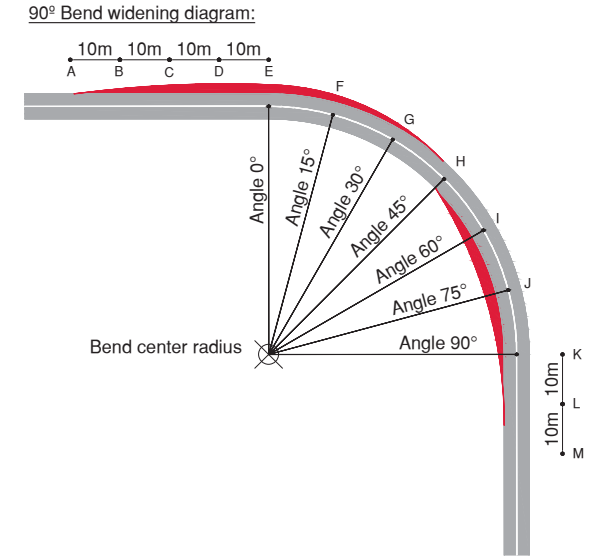

60° BEND WIDENING - 6 METERS WIDE ROAD											
Radius	External						Internal				
	A	B	C	D	E	F	G	H	I	J	K
55m	-	1.0	2.3	2.8	2.2	-	-	1.5	0.4	0.2	-
60m	-	0.7	1.9	2.5	1.7	-	-	0.2	0.2	-	-
65m	-	0.5	1.5	2.2	1.4	-	-	-	0.2	-	-

90° BEND WIDENING - 6 METERS WIDE ROAD													
Radius	External						Internal						
	A	B	C	D	E	F	G	H	I	J	K	L	M
55m	-	0.7	2.0	2.9	2.5	1.4	0.6	-	0.4	0.9	0.4	-	-
60m	-	0.7	1.5	2.0	1.7	0.7	0.2	-	0.2	0.9	0.2	-	-
65m	-	0.5	1.3	1.7	1.6	0.6	0.2	-	0.2	0.8	-	-	-

60° BEND WIDENING - 6.5 METERS WIDE ROAD											
Radius	External						Internal				
	A	B	C	D	E	F	G	H	I	J	K
55m	-	0.5	1.8	2.3	1.7	-	-	1.0	-	-	-
60m	-	0.2	1.4	2.0	1.2	-	-	-	-	-	-
65m	-	-	1.0	1.7	0.9	-	-	-	-	-	-

90° BEND WIDENING - 6.5 METERS WIDE ROAD													
Radius	External						Internal						
	A	B	C	D	E	F	G	H	I	J	K	L	M
55m	-	0.3	1.5	2.4	2.0	1.0	0.2	-	-	0.4	-	-	-
60m	-	0.3	1.0	1.5	1.2	0.2	-	-	-	0.4	-	-	-
65m	-	-	0.8	1.2	1.1	0.2	-	-	-	0.3	-	-	-

120° BEND WIDENING - 5 METERS WIDE ROAD															
Radius	External							Internal							
	A	B	C	D	E	F	G	H	I	J	K	L	M	N	O
55m	0.5	2.0	3.1	3.8	3.4	2.2	1.6	1.3	1.0	-	1.8	2.4	1.4	0.3	-
60m	0.1	1.6	2.8	3.4	2.7	1.5	1.3	1.2	1.0	-	0.8	1.8	1.1	0.3	-
65m	-	1.4	2.6	3.1	2.4	1.0	1.0	0.8	0.8	-	0.6	1.4	0.8	-	-

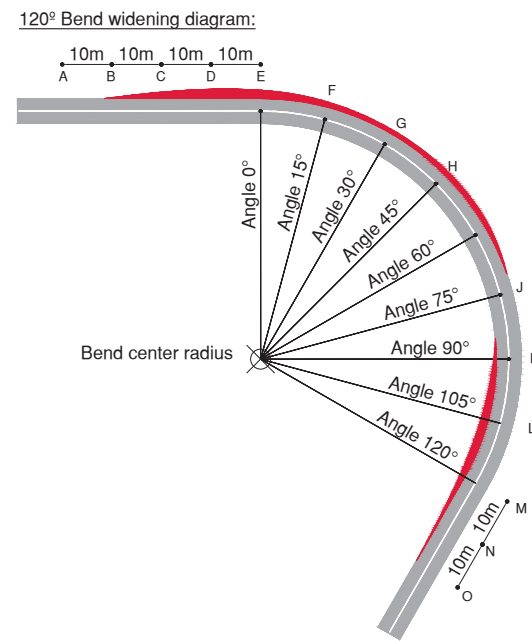

150° BEND WIDENING - 5 METERS WIDE ROAD																	
Radius	External									Internal							
	A	B	C	D	E	F	G	H	I	J	K	L	M	N	O	P	Q
55m	0.2	1.9	3.2	3.8	3.5	2.5	1.5	1.2	1.2	1.1	0.9	-	1.9	2.9	1.9	0.4	-
60m	0.2	1.6	2.5	3.0	2.8	1.8	1.2	1.1	1.1	1.0	0.9	-	0.8	1.9	1.0	-	-
65m	-	1.4	2.2	2.8	2.5	1.5	1.1	1.0	1.0	0.9	0.9	-	0.6	1.5	0.6	-	-

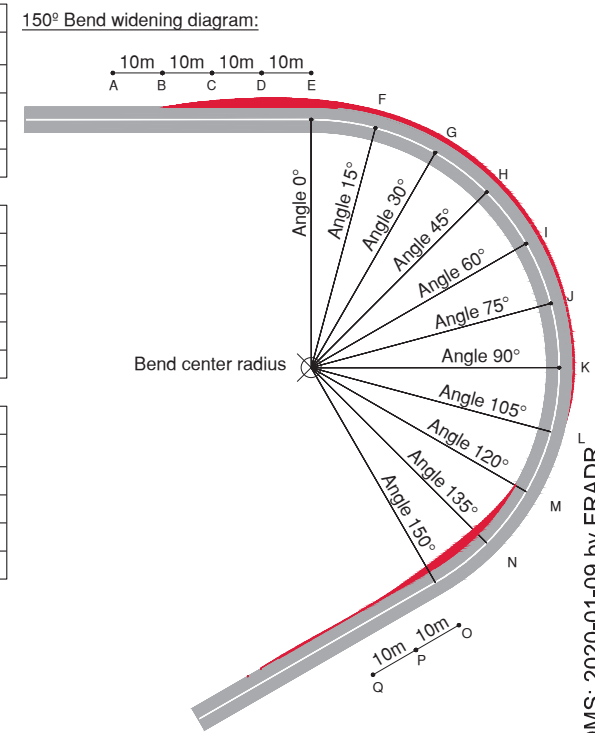

120° BEND WIDENING - 6 METERS WIDE ROAD															
Radius	External							Internal							
	A	B	C	D	E	F	G	H	I	J	K	L	M	N	O
55m	-	1.1	2.2	2.8	2.4	1.2	0.6	0.4	0.2	-	0.9	1.4	0.4	-	-
60m	-	0.7	1.8	2.4	1.7	0.6	0.4	0.3	0.2	-	-	0.8	0.2	-	-
65m	-	0.5	1.6	2.1	1.4	0.2	0.2	-	-	-	-	0.5	0.2	-	-

150° BEND WIDENING - 6 METERS WIDE ROAD																	
Radius	External									Internal							
	A	B	C	D	E	F	G	H	I	J	K	L	M	N	O	P	Q
55m	-	1.0	2.2	2.8	2.5	1.5	0.6	0.4	0.4	0.2	-	-	1.0	2.0	1.0	-	-
60m	-	0.6	1.5	2.0	1.8	0.8	0.4	0.2	0.2	0.2	-	-	0.2	1.0	0.2	-	-
65m	-	0.4	1.2	1.8	1.5	0.6	0.2	0.2	0.2	-	-	-	-	0.6	-	-	-

120° BEND WIDENING - 6.5 METERS WIDE ROAD															
Radius	External							Internal							
	A	B	C	D	E	F	G	H	I	J	K	L	M	N	O
55m	-	0.6	1.7	2.3	1.9	0.7	0.2	-	-	-	0.4	1.0	-	-	-
60m	-	0.2	1.3	1.9	1.2	0.2	-	-	-	-	-	0.4	-	-	-
65m	-	-	1.1	1.6	0.9	-	-	-	-	-	-	0.2	-	-	-

150° BEND WIDENING - 6.5 METERS WIDE ROAD																	
Radius	External									Internal							
	A	B	C	D	E	F	G	H	I	J	K	L	M	N	O	P	Q
55m	-	0.5	1.7	2.3	2.0	1.0	0.2	-	-	-	-	-	0.5	1.5	0.5	-	-
60m	-	0.2	1.0	1.5	1.3	0.3	-	-	-	-	-	-	-	0.5	-	-	-
65m	-	-	0.7	1.3	1.0	0.2	-	-	-	-	-	-	-	0.2	-	-	-

Design has been defined considering the following truck dimensions:

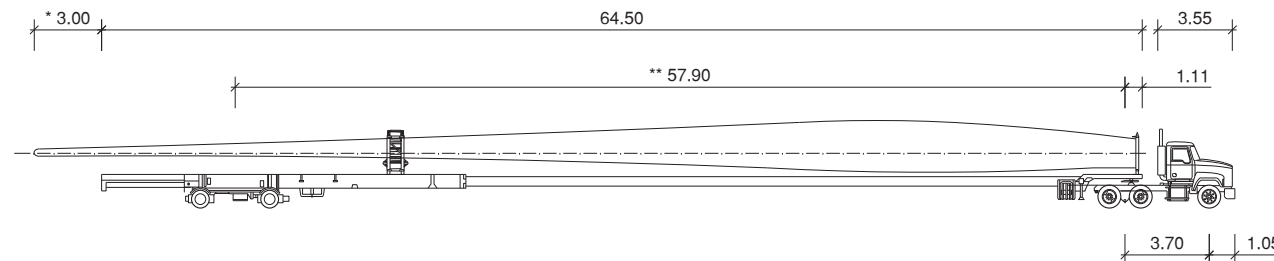

*The blade overhang requires an additional area to be cleared and free of obstacles outside the bend. The width of this additional area will be equal to the blade overhang. This additional area will be parallel to the road extra-widening.

**The distance between the axels requires an additional area to be cleared and free of obstacles inside the bend. This additional area will change depending of the truck and the bending radius and should be checked case-by-case.

-Different dimensions will lead to substantially different results.
-All units provided are in meters.

DESIGN REQUIREMENTS	
Minimum vertical curve parameter	$K_v = L / i_1 - i_2 = 500$
Maximum slope on gravel road	9%
Maximum slope on concrete road	14%
Minimum radius	55m
Min. straight length before/after the bend *	110m
* Additional bend wides provided in this drawing, will not be valid if this minimum straight length are not respected.	

60° BEND WIDENING - 5 METERS WIDE ROAD												
Radius	External						Internal					
	A	B	C	D	E	F	G	H	I	J	K	
70m	-	0.2	1.2	1.6	1.2	0.1	-	1.3	1.1	0.4	0.2	
75m	-	-	0.8	1.4	0.8	-	-	1.0	0.8	0.3	-	
80m	-	-	0.8	1.1	0.7	-	-	1.0	0.7	0.3	-	

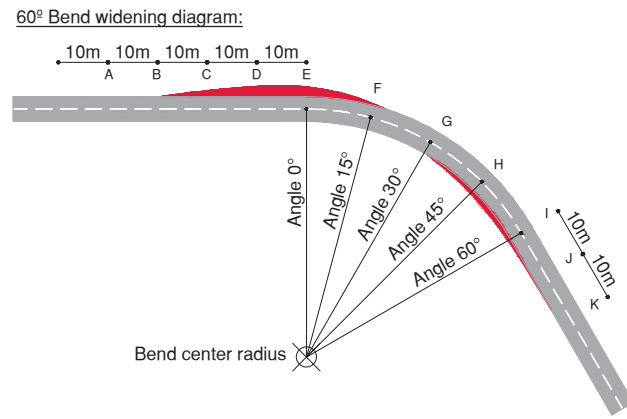

90° BEND WIDENING - 5 METERS WIDE ROAD													
Radius	External						Internal						
	A	B	C	D	E	F	G	H	I	J	K		
70m	-	0.7	1.5	1.7	1.3	0.2	-	-	-	1.2	1.7	1.1	0.4
75m	-	0.5	1.2	1.4	1.0	-	-	-	-	1.0	1.4	0.8	0.2
80m	-	0.2	1.0	1.3	0.9	-	-	-	-	0.6	0.9	0.6	0.2

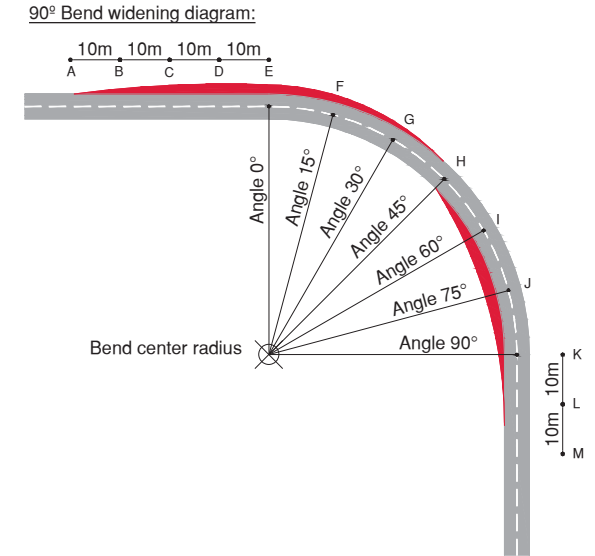

60° BEND WIDENING - 6 METERS WIDE ROAD												
Radius	External						Internal					
	A	B	C	D	E	F	G	H	I	J	K	
70m	-	-	0.4	0.8	0.4	-	-	0.2	0.2	-	-	
75m	-	-	0.2	0.6	0.2	-	-	0.2	-	-	-	
80m	-	-	-	0.2	-	-	-	0.2	-	-	-	

90° BEND WIDENING - 6 METERS WIDE ROAD													
Radius	External						Internal						
	A	B	C	D	E	F	G	H	I	J	K		
70m	-	-	0.5	0.6	0.2	-	-	-	-	0.6	0.1	-	-
75m	-	-	0.4	0.6	-	-	-	-	-	0.4	-	-	-
80m	-	-	0.3	0.6	-	-	-	-	-	-	-	-	-

60° BEND WIDENING - 6.5 METERS WIDE ROAD												
Radius	External						Internal					
	A	B	C	D	E	F	G	H	I	J	K	
70m	-	-	-	0.4	-	-	-	-	-	-	-	
75m	-	-	-	0.2	-	-	-	-	-	-	-	
80m	-	-	-	-	-	-	-	-	-	-	-	

90° BEND WIDENING - 6.5 METERS WIDE ROAD												
Radius	External						Internal					
	A	B	C	D	E	F	G	H	I	J	K	
70m	-	-	0.2	0.4	-	-	-	-	-	-	-	-
75m	-	-	-	0.4	-	-	-	-	-	-	-	-
80m	-	-	-	-	-	-	-	-	-	-	-	-

120° BEND WIDENING - 5 METERS WIDE ROAD														
Radius	External							Internal						
	A	B	C	D	E	F	G	H	I	J	K	L	M	N
70m	-	0.9	1.8	2.0	1.2	0.1	-	-	-	0.7	1.6	0.9	0.2	-
75m	-	0.6	1.5	1.6	1.0	-	-	-	-	0.5	1.2	0.8	0.2	-
80m	-	0.3	1.1	1.4	1.0	-	-	-	-	-	0.9	0.7	0.2	-

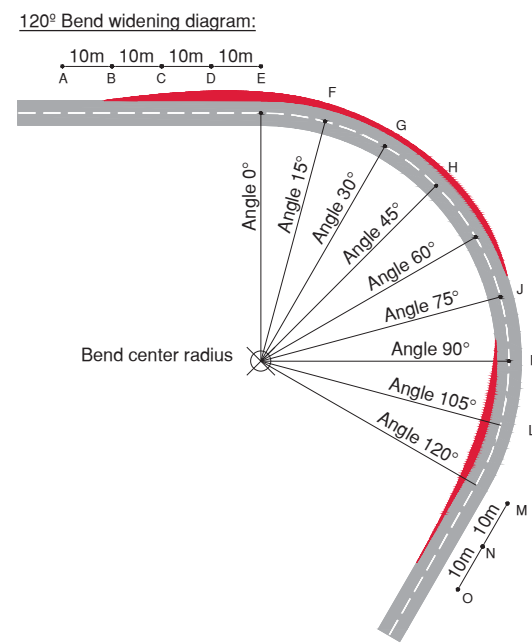

150° BEND WIDENING - 5 METERS WIDE ROAD																	
Radius	External									Internal							
	A	B	C	D	E	F	G	H	I	J	K	L	M	N	O	P	Q
70m	-	0.7	1.7	2.0	1.4	-	-	-	-	-	-	-	0.3	1.3	1.1	0.8	0.4
75m	-	0.5	1.4	1.6	1.2	-	-	-	-	-	-	-	0.2	1.0	0.8	0.6	0.3
80m	-	0.2	1.1	1.3	0.9	-	-	-	-	-	-	-	-	0.6	0.7	0.5	0.3

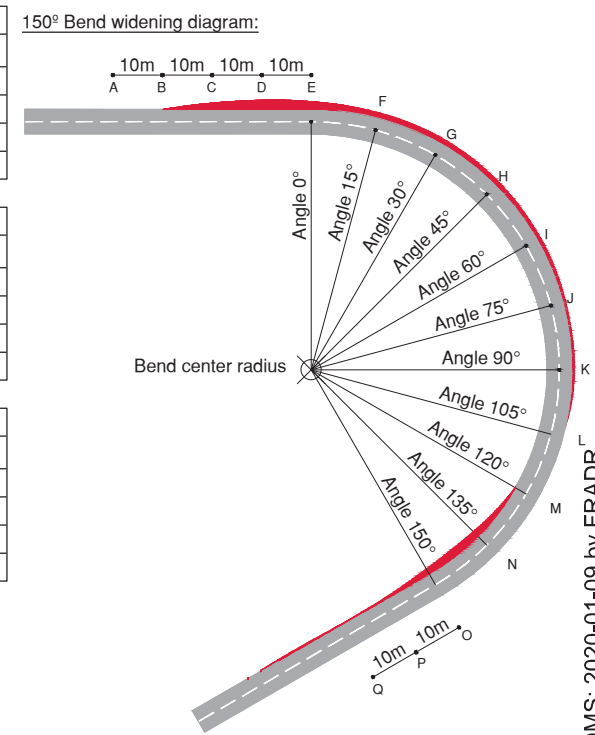

120° BEND WIDENING - 6 METERS WIDE ROAD														
Radius	External							Internal						
	A	B	C	D	E	F	G	H	I	J	K	L	M	N
70m	-	-	0.6	0.8	0.2	-	-	-	-	0.5	0.3	-	-	-
75m	-	-	0.4	0.5	-	-	-	-	-	0.4	0.2	-	-	-
80m	-	-	0.2	0.3	-	-	-	-	-	-	-	-	-	-

150° BEND WIDENING - 6 METERS WIDE ROAD																	
Radius	External									Internal							
	A	B	C	D	E	F	G	H	I	J	K	L	M	N	O	P	Q
70m	-	-	0.8	1.0	0.4	-	-	-	-	-	-	-	0.4	-	-	-	-
75m	-	-	0.4	0.7	0.2	-	-	-	-	-	-	-	0.2	-	-	-	-
80m	-	-	0.2	0.3	0.2	-	-	-	-	-	-	-	-	-	-	-	-

120° BEND WIDENING - 6.5 METERS WIDE ROAD														
Radius	External							Internal						
	A	B	C	D	E	F	G	H	I	J	K	L	M	N
70m	-	-	0.2	0.4	-	-	-	-	-	-	-	-	-	-
75m	-	-	-	0.2	-	-	-	-	-	-	-	-	-	-
80m	-	-	-	-	-	-	-	-	-	-	-	-	-	-

150° BEND WIDENING - 6.5 METERS WIDE ROAD																	
Radius	External									Internal							
	A	B	C	D	E	F	G	H	I	J	K	L	M	N	O	P	Q
70m	-	-	0.4	0.5	-	-	-	-	-	-	-	-	-	-	-	-	-
75m	-	-	-	0.3	-	-	-	-	-	-	-	-	-	-	-	-	-
80m	-	-	-	-	-	-	-	-	-	-	-	-	-	-	-	-	-

Design has been defined considering the following truck dimensions:

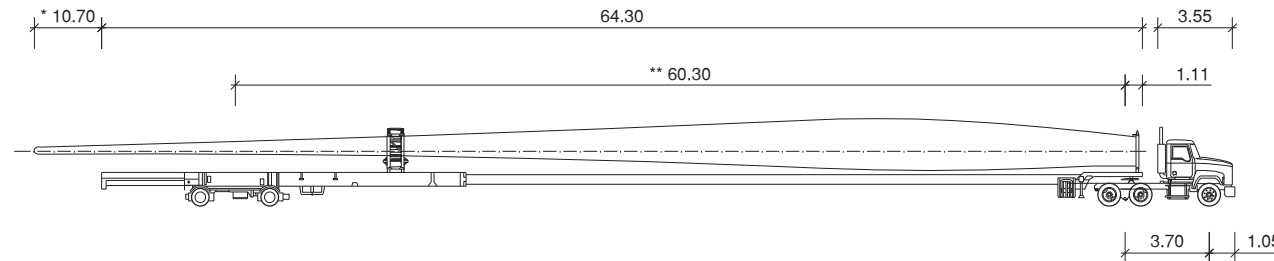

*The blade overhang requires an additional area to be cleared and free of obstacles outside the bend. The width of this additional area will be equal to the blade overhang. This additional area will be parallel to the road extra-widening.

**The distance between the axels requires an additional area to be cleared and free of obstacles inside the bend. This additional area will change depending of the truck and the bending radius and should be checked case-by-case.

-Different dimensions will lead to substantially different results.
-All units provided are in meters.

DESIGN REQUIREMENTS	
Minimum vertical curve parameter	$K_v = L / i_1 - i_2 = 500$
Maximum slope on gravel road	9%
Maximum slope on concrete road	14%
Minimum radius	70m
Min. straight length before/after the bend *	160m
* Additional bend wides provided in this drawing, will not be valid if this minimum straight length are not respected.	

60° BEND WIDENING - 5 METERS WIDE ROAD												
Radius	External						Internal					
	A	B	C	D	E	F	G	H	I	J	K	
70m	-	0.2	1.2	1.6	1.2	0.1	-	1.3	1.1	0.4	0.2	
75m	-	-	0.8	1.4	0.8	-	-	1.0	0.8	0.3	-	
80m	-	-	0.8	1.1	0.7	-	-	1.0	0.7	0.3	-	

60° Bend widening diagram:

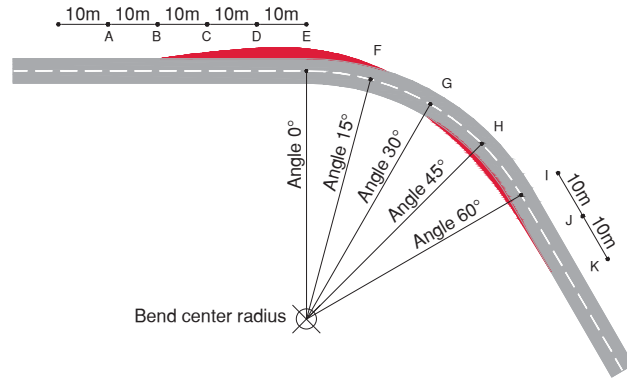

90° BEND WIDENING - 5 METERS WIDE ROAD													
Radius	External						Internal						
	A	B	C	D	E	F	G	H	I	J	K		
70m	-	0.7	1.5	1.7	1.3	0.2	-	-	-	1.2	1.7	1.1	0.4
75m	-	0.5	1.2	1.4	1.0	-	-	-	-	1.0	1.4	0.8	0.2
80m	-	0.2	1.0	1.3	0.9	-	-	-	-	0.6	0.9	0.6	0.2

90° Bend widening diagram:

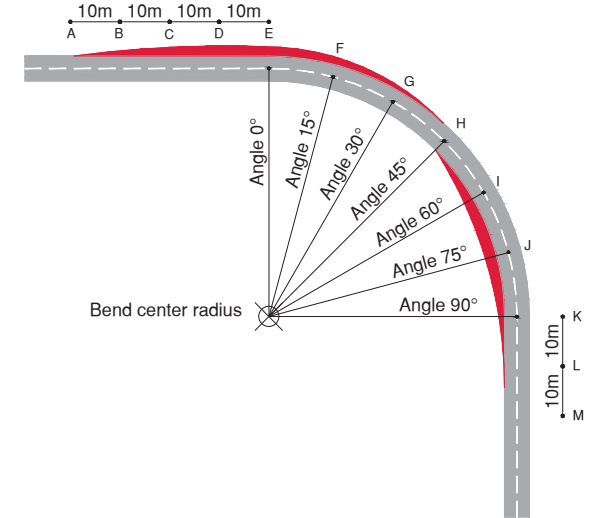

60° BEND WIDENING - 6 METERS WIDE ROAD												
Radius	External						Internal					
	A	B	C	D	E	F	G	H	I	J	K	
70m	-	-	0.4	0.8	0.4	-	-	0.2	0.2	-	-	
75m	-	-	0.2	0.6	0.2	-	-	0.2	-	-	-	
80m	-	-	-	0.2	-	-	-	0.2	-	-	-	

90° BEND WIDENING - 6 METERS WIDE ROAD													
Radius	External						Internal						
	A	B	C	D	E	F	G	H	I	J	K		
70m	-	-	0.5	0.6	0.2	-	-	-	-	0.6	0.1	-	-
75m	-	-	0.4	0.6	-	-	-	-	-	0.4	-	-	-
80m	-	-	0.3	0.6	-	-	-	-	-	-	-	-	-

60° BEND WIDENING - 6.5 METERS WIDE ROAD												
Radius	External						Internal					
	A	B	C	D	E	F	G	H	I	J	K	
70m	-	-	-	0.4	-	-	-	-	-	-	-	
75m	-	-	-	0.2	-	-	-	-	-	-	-	
80m	-	-	-	-	-	-	-	-	-	-	-	

90° BEND WIDENING - 6.5 METERS WIDE ROAD													
Radius	External						Internal						
	A	B	C	D	E	F	G	H	I	J	K		
70m	-	-	0.2	0.4	-	-	-	-	-	-	-	-	-
75m	-	-	-	0.4	-	-	-	-	-	-	-	-	-
80m	-	-	-	-	-	-	-	-	-	-	-	-	-

120° BEND WIDENING - 5 METERS WIDE ROAD															
Radius	External							Internal							
	A	B	C	D	E	F	G	H	I	J	K	L	M	N	O
70m	-	0.9	1.8	2.0	1.2	0.1	-	-	-	-	0.7	1.6	0.9	0.2	-
75m	-	0.6	1.5	1.6	1.0	-	-	-	-	-	0.5	1.2	0.8	0.2	-
80m	-	0.3	1.1	1.4	1.0	-	-	-	-	-	-	0.9	0.7	0.2	-

120° Bend widening diagram:

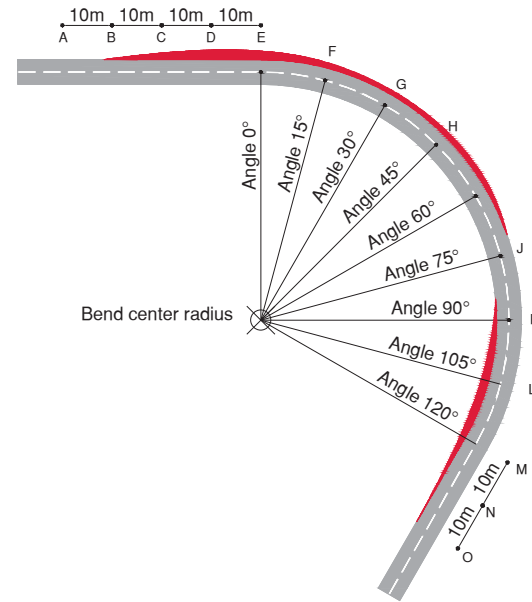

150° BEND WIDENING - 5 METERS WIDE ROAD																
Radius	External									Internal						
	A	B	C	D	E	F	G	H	I	J	K	L	M	N	O	P
70m	-	0.7	1.7	2.0	1.4	-	-	-	-	-	-	0.3	1.3	1.1	0.8	0.4
75m	-	0.5	1.4	1.6	1.2	-	-	-	-	-	-	0.2	1.0	0.8	0.6	0.3
80m	-	0.2	1.1	1.3	0.9	-	-	-	-	-	-	-	0.6	0.7	0.5	0.3

150° Bend widening diagram:

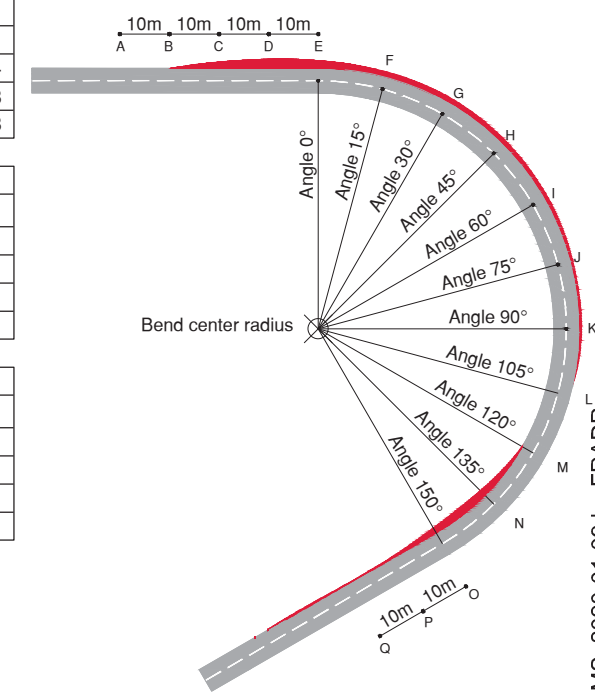

120° BEND WIDENING - 6 METERS WIDE ROAD														
Radius	External							Internal						
	A	B	C	D	E	F	G	H	I	J	K	L	M	N
70m	-	-	0.6	0.8	0.2	-	-	-	-	-	0.5	0.3	-	-
75m	-	-	0.4	0.5	-	-	-	-	-	-	0.4	0.2	-	-
80m	-	-	0.2	0.3	-	-	-	-	-	-	-	-	-	-

150° BEND WIDENING - 6 METERS WIDE ROAD																
Radius	External									Internal						
	A	B	C	D	E	F	G	H	I	J	K	L	M	N	O	P
70m	-	-	0.8	1.0	0.4	-	-	-	-	-	-	0.4	-	-	-	-
75m	-	-	0.4	0.7	0.2	-	-	-	-	-	-	0.2	-	-	-	-
80m	-	-	0.2	0.3	0.2	-	-	-	-	-	-	-	-	-	-	-

120° BEND WIDENING - 6.5 METERS WIDE ROAD															
Radius	External							Internal							
	A	B	C	D	E	F	G	H	I	J	K	L	M	N	O
70m	-	-	0.2	0.4	-	-	-	-	-	-	-	-	-	-	-
75m	-	-	-	0.2	-	-	-	-	-	-	-	-	-	-	-
80m	-	-	-	-	-	-	-	-	-	-	-	-	-	-	-

150° BEND WIDENING - 6.5 METERS WIDE ROAD																
Radius	External									Internal						
	A	B	C	D	E	F	G	H	I	J	K	L	M	N	O	P
70m	-	-	0.4	0.5	-	-	-	-	-	-	-	-	-	-	-	-
75m	-	-	-	0.3	-	-	-	-	-	-	-	-	-	-	-	-
80m	-	-	-	-	-	-	-	-	-	-	-	-	-	-	-	-

Design has been defined considering the following truck dimensions:

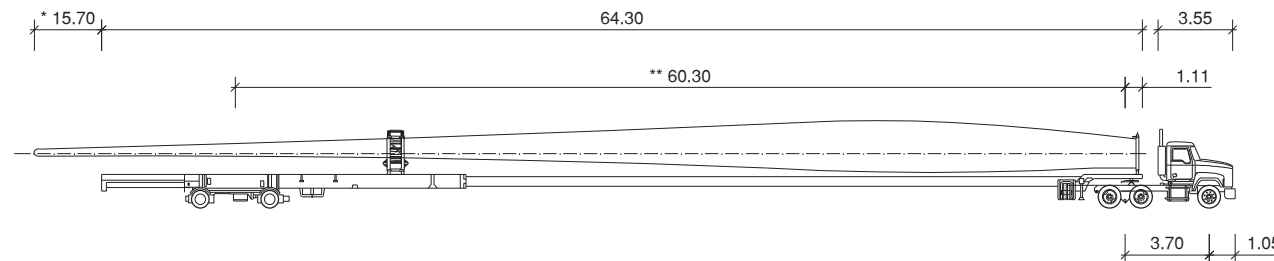

*The blade overhang requires an additional area to be cleared and free of obstacles outside the bend. The width of this additional area will be equal to the blade overhang. This additional area will be parallel to the road extra-widening.

**The distance between the axles requires an additional area to be cleared and free of obstacles inside the bend. This additional area will change depending of the truck and the bending radius and should be checked case-by-case.

-Different dimensions will lead to substantially different results.
-All units provided are in meters.

DESIGN REQUIREMENTS	
Minimum vertical curve parameter	$K_v = L / i_1 - i_2 = 500$
Maximum slope on gravel road	9%
Maximum slope on concrete road	14%
Minimum radius	70m
Min. straight length before/after the bend *	160m
* Additional bend wides provided in this drawing, will not be valid if this minimum straight length are not respected.	