

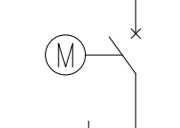

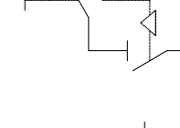

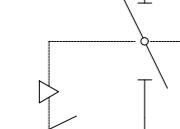
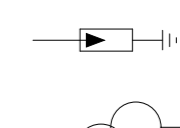
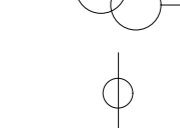
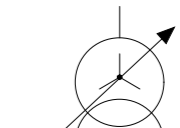
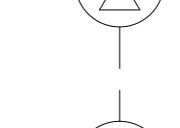
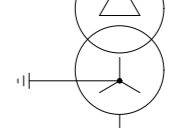

LEGENDA

-  INTERRUTTORE AT CON COMANDO MOTORIZZATO
-  SEZIONATORE MANUALE AT CON INTERBLOCCO LAME DI TERRA
-  SEZIONATORE MOTORIZZATO ROTATIVO AT CON INTERBLOCCO LAME DI TERRA
-  SCARICATORE
-  TRASFORMATORE DI TENSIONE
-  TRASFORMATORE DI CORRENTE
-  TRASFORMATORE DI POTENZA (COMMUTATORE SOTTO CARICO MOTORIZZATO)
-  TRASFORMATORE SERVIZI AUSILIARI
-  GENERATORE ASINCRONO
-  FUSIBILE
-  INTERRUTTORE MT ASPORTABILE CON COMANDO MOTORIZZATO
-  INDICATORE CAPACITIVO PRESENZA TENSIONE
-  LAME DI MESSA A TERRA
-  INTERRUTTORE AUTOMATICO
-  CONTATORE DI MANOVRA
-  SEZIONATORE ROTATIVO CON MESSA A TERRA
-  SEZIONATORE ROTATIVO SOTTOCARICO CON MESSA A TERRA
-  LAMPADA DI SEGNALE
-  BLOCCO A CHIAVE, CHIAVE LIBERA IN APERTO
-  BLOCCO A CHIAVE, CHIAVE LIBERA IN CHIUSO
-  CONTATORE DI ENERGIA ATTIVA/REATTIVA ENTRANTE-USCENTE PER MISURE FISCALI
-  MODULO IBRIDO 150 kV (Maggiori dettagli sono riportati nell'elaborato "GEOE083 Relazione tecnica descrittiva connessione RTN Tema")
-  TA A 3 NUCLEI
-  SEZIONATORE
-  TV CAPACITIVO
-  TERMINALE ARIA - CAVO

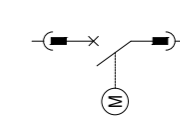
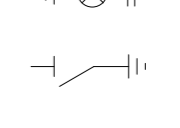
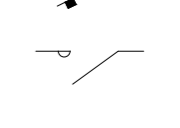
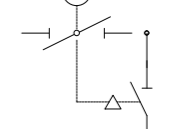
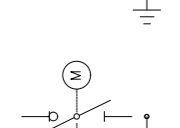
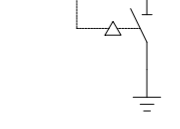
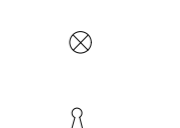
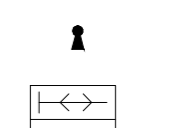

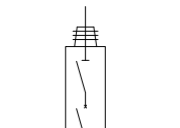
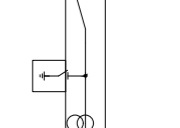
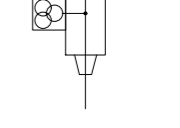
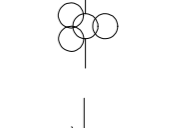
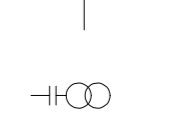
IMPIANTO EOLICO

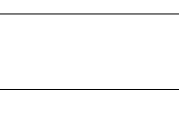
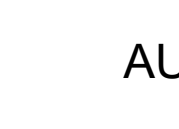
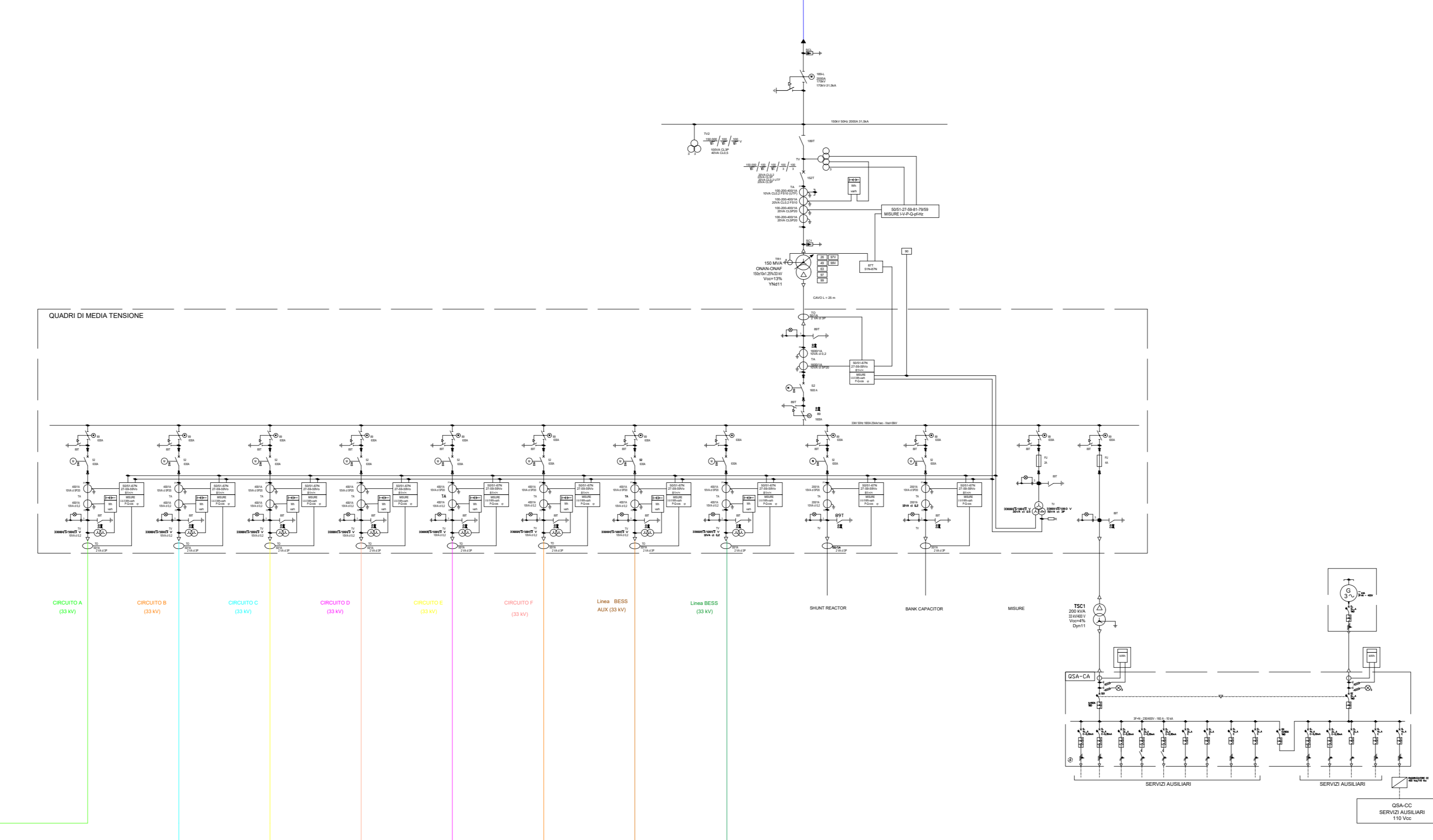
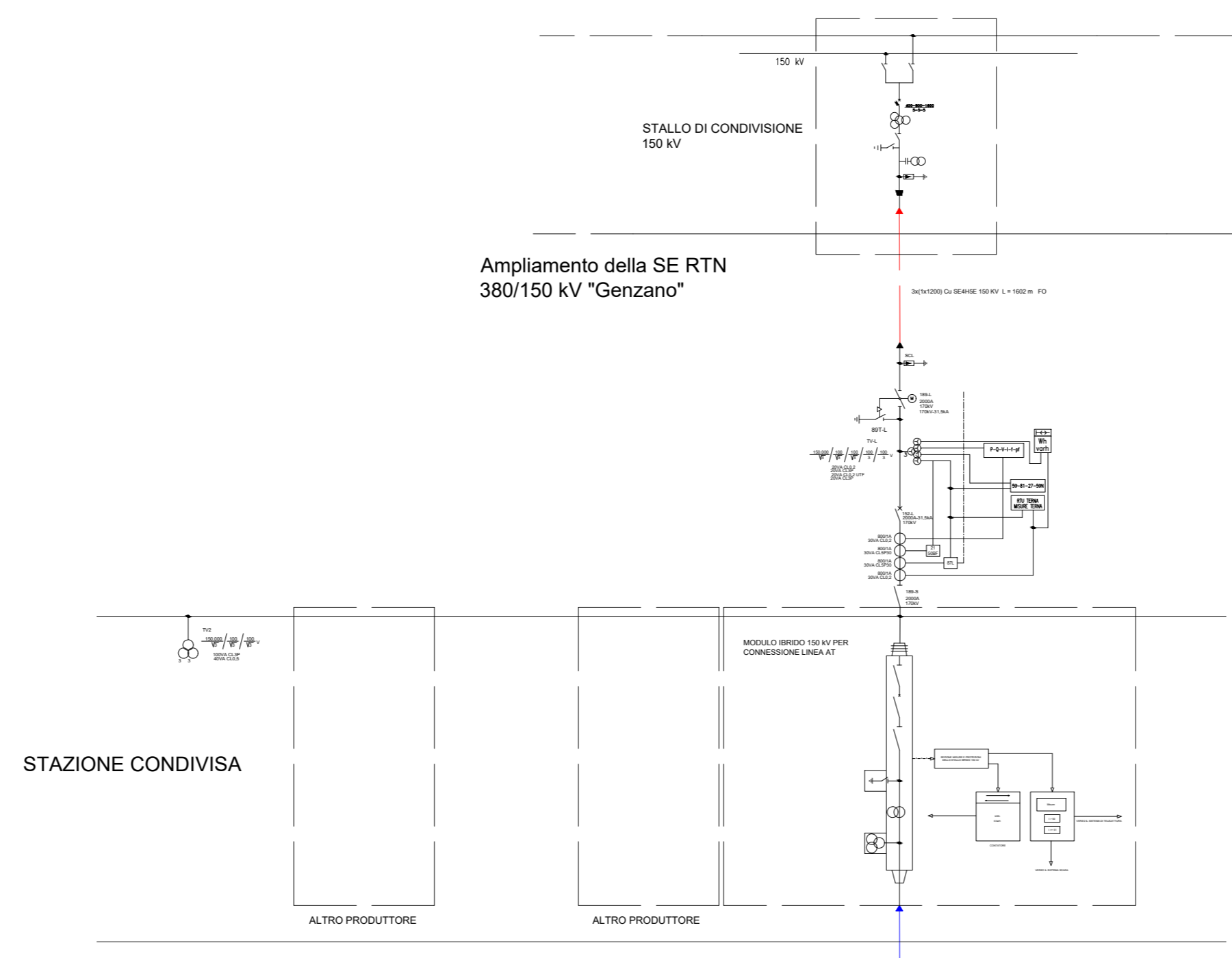
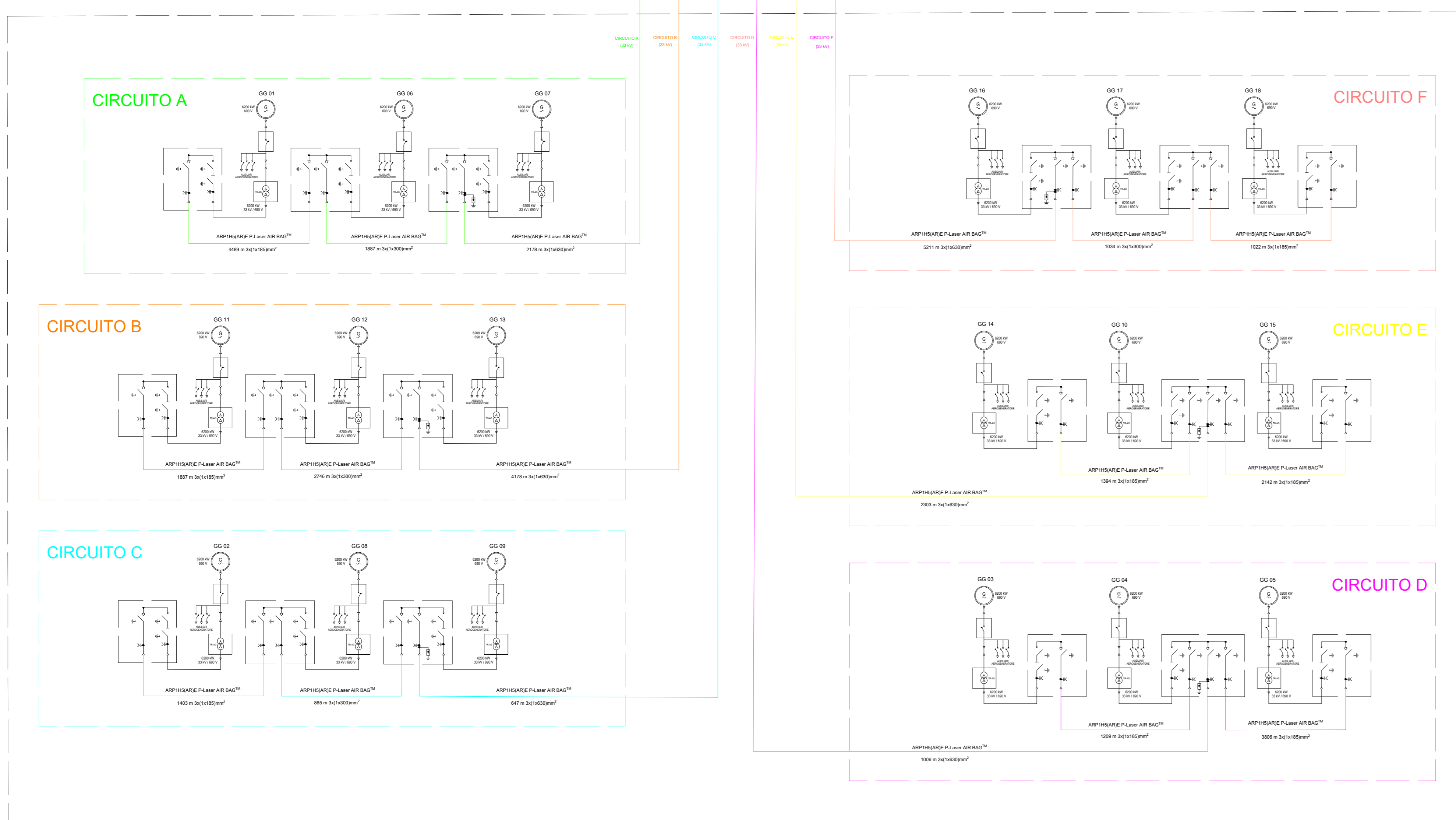
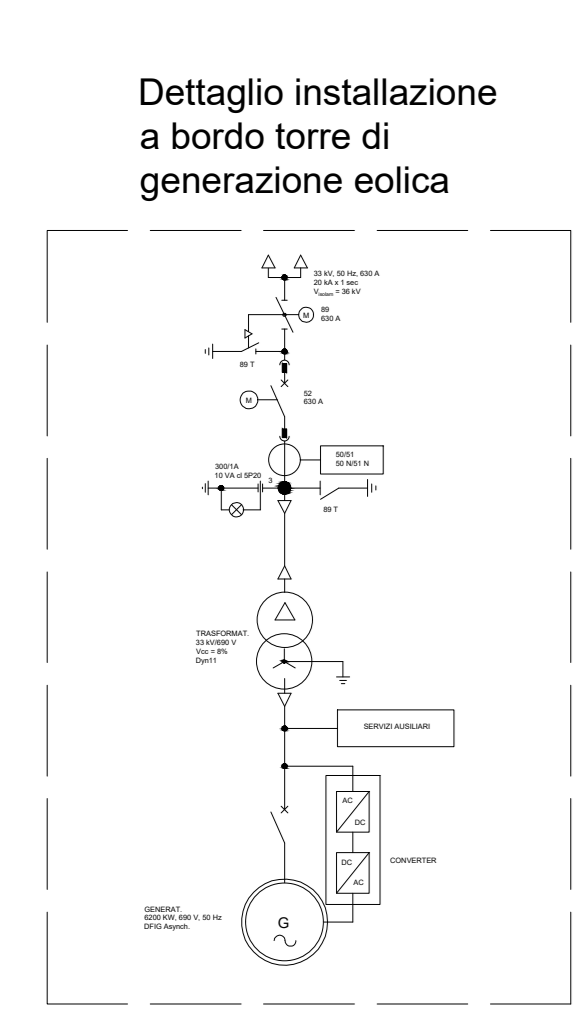

IMPIANTO BESS (BATTERY ENERGY STORAGE SYSTEM)

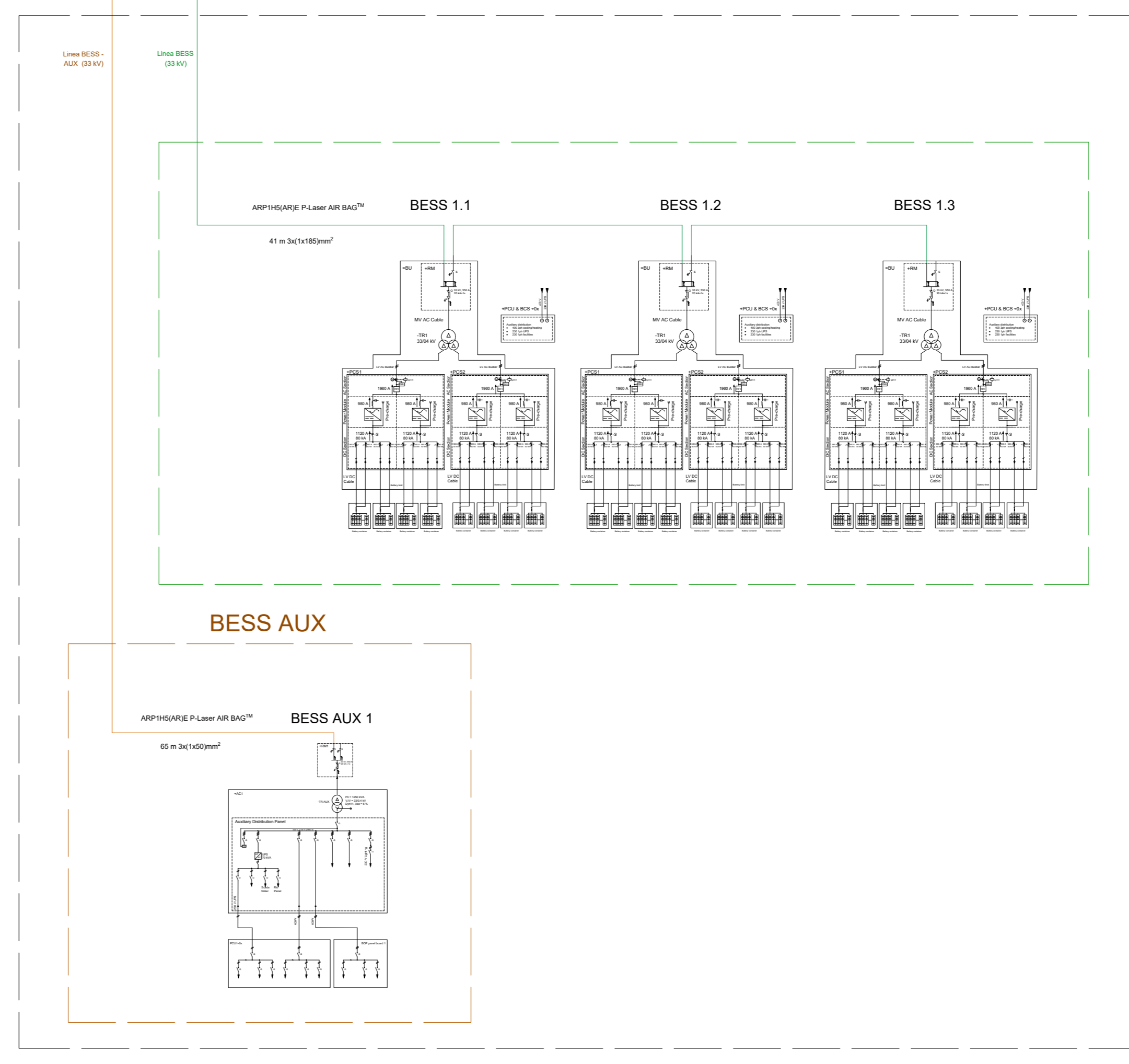

AUTORIZZAZIONE UNICA EX D. LGS. N. 387/2003

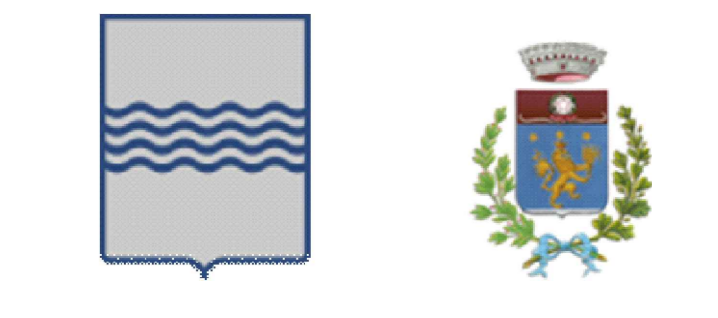







PROGETTO DEFINITIVO
PARCO EOLICO GENZANO

Titolo elaborato:
SCHEMA ELETTRICO UNIFILARE DEGLI IMPIANTI DI UTENTE E DI RTN (LIMITATAMENTE ALLO STALLO DI COMPETENZA)

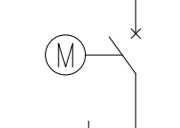
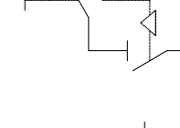
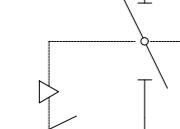
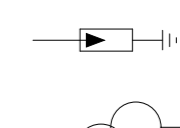
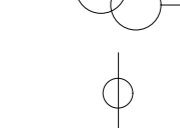
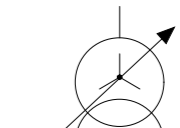
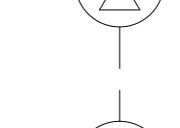
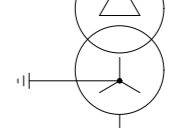
SS	LT	GD	Prima emissione	04/08/2023	00
REDDATTO	CONTR.	APPROV.	DESCRIZIONE REVISIONE DOCUMENTO	DATA	REV

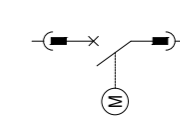
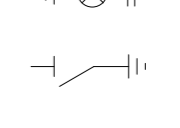
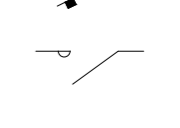
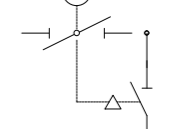
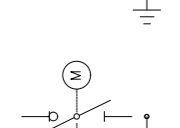
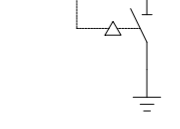
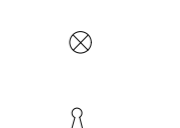
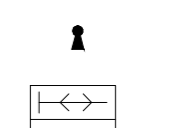
<p>PROPRONTE</p>  <p>LUCANIA PRIME S.R.L. Via A. De Gasperi n.8 74023 Grottaglie (TA)</p>	<p>CONSULENZA</p>  <p>GE.CO.D'OR. S.R.L. Via A. De Gasperi n.8 74023 Grottaglie (TA)</p> <p>PROGETTISTA Ing. Gaetano D'Oronzio Via Goito 14 - Colobraro (MT)</p>
--	--

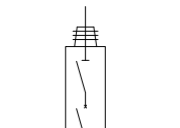
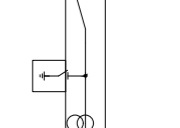
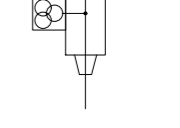
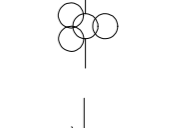
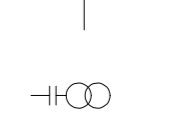
LEGENDA

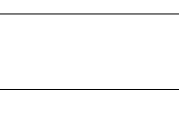
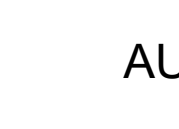
-  INTERRUTTORE AT CON COMANDO MOTORIZZATO
-  SEZIONATORE MANUALE AT CON INTERBLOCCO LAME DI TERRA
-  SEZIONATORE MOTORIZZATO ROTATIVO AT CON INTERBLOCCO LAME DI TERRA
-  SCARICATORE
-  TRASFORMATORE DI TENSIONE
-  TRASFORMATORE DI CORRENTE
-  TRASFORMATORE DI POTENZA (COMMUTATORE SOTTO CARICO MOTORIZZATO)
-  TRASFORMATORE SERVIZI AUSILIARI
-  GENERATORE ASINCRONO
-  FUSIBILE
-  INTERRUTTORE MT ASPORTABILE CON COMANDO MOTORIZZATO
-  INDICATORE CAPACITIVO PRESENZA TENSIONE
-  LAME DI MESSA A TERRA
-  INTERRUTTORE AUTOMATICO
-  CONTATORE DI MANOVRA
-  SEZIONATORE ROTATIVO CON MESSA A TERRA
-  SEZIONATORE ROTATIVO SOTTOCARICO CON MESSA A TERRA
-  LAMPADA DI SEGNALAZIONE
-  BLOCCO A CHIAVE, CHIAVE LIBERA IN APERTO
-  BLOCCO A CHIAVE, CHIAVE LIBERA IN CHIUSO
-  CONTATORE DI ENERGIA ATTIVA/REATTIVA ENTRANTE-USCENTE PER MISURE FISCALI
-  MODULO IBRIDO 150 kV (Maggiori dettagli sono riportati nell'elaborato "GEOE083 Relazione tecnica descrittiva connessione RTN Tema")
-  TA A 3 NUCLEI
-  SEZIONATORE
-  TV CAPACITIVO
-  TERMINALE ARIA - CAVO

IMPIANTO EOLICO

Dettaglio installazione a bordo torre di generazione eolica

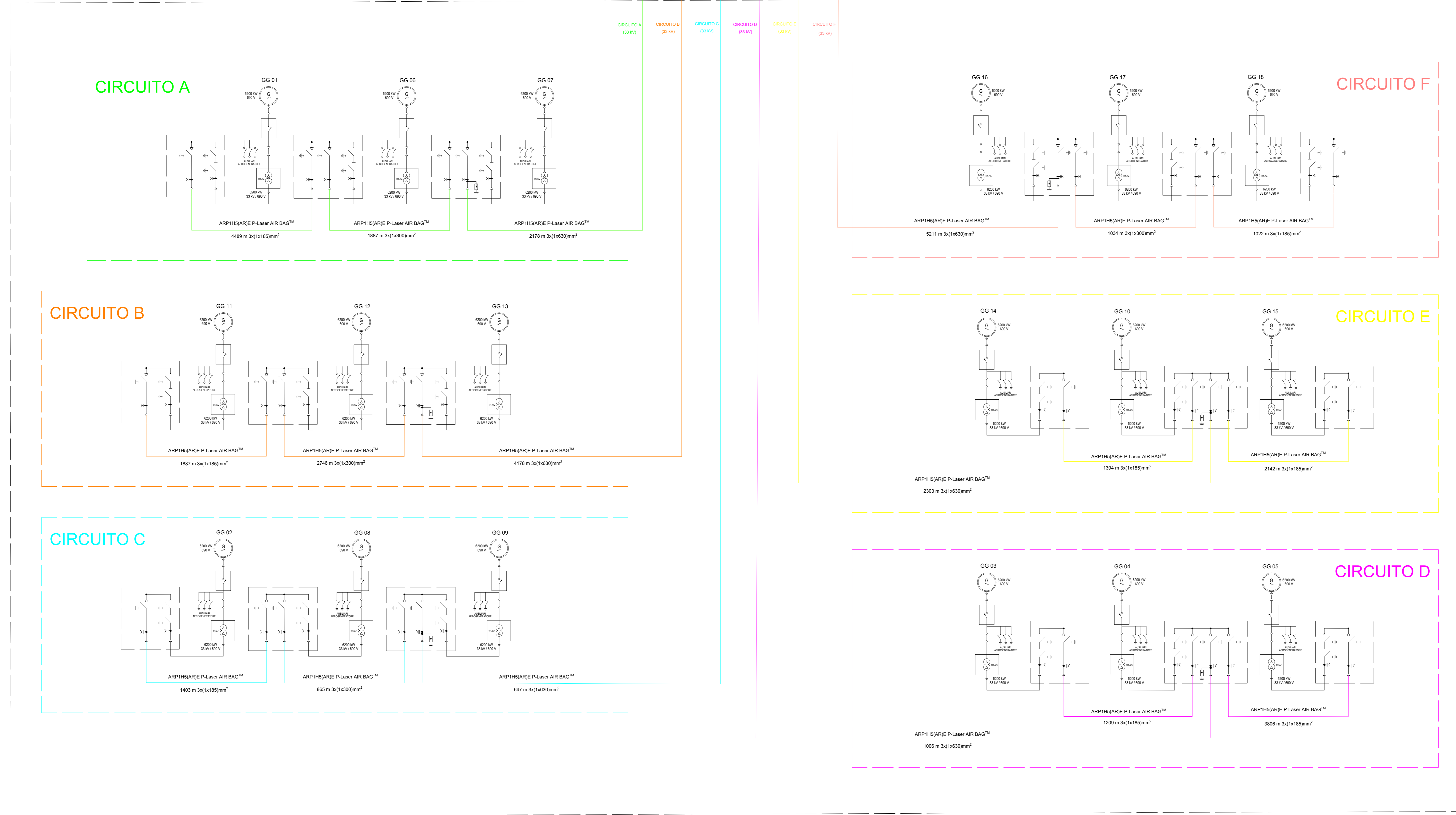
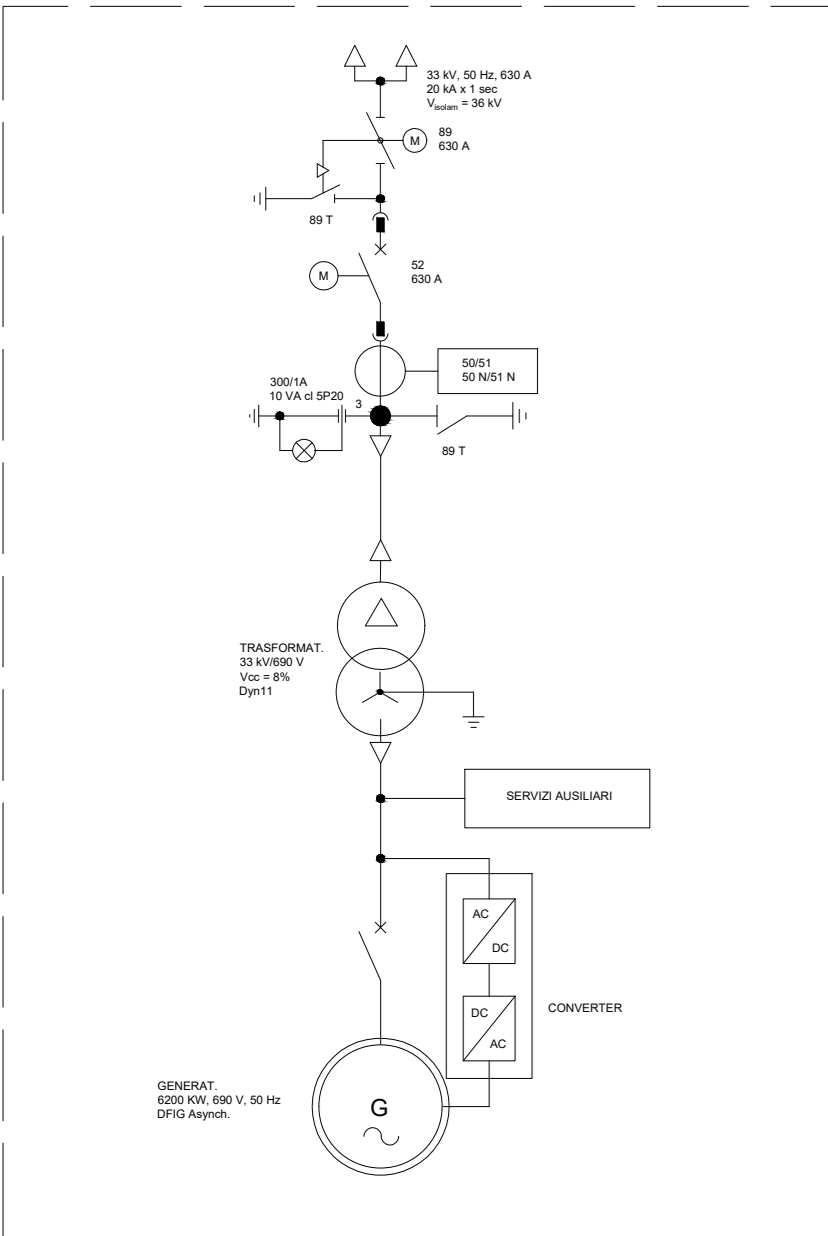

AUTORIZZAZIONE UNICA EX D. LGS. N. 387/2003

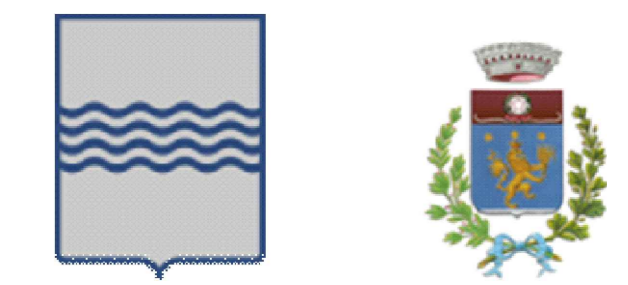

PROGETTO DEFINITIVO
PARCO EOLICO GENZANO

Titolo elaborato:







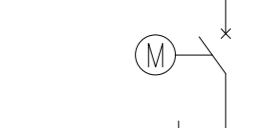
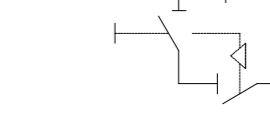
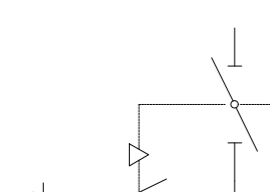
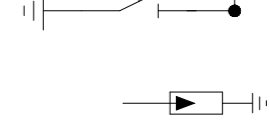
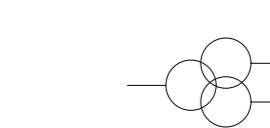

SCHEMA ELETTRICO UNIFILARE DEGLI IMPIANTI DI UTENTE E DI RTN (LIMITATAMENTE ALLO STALLO DI COMPETENZA)

SS	LT	GD	Prima emissione	04/08/2023	00
REDDATTO	CONTR.	APPROV.	DESCRIZIONE REVISIONE DOCUMENTO	DATA	REV

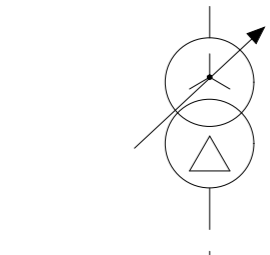
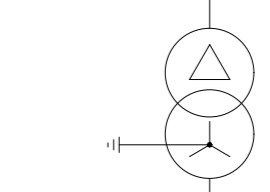
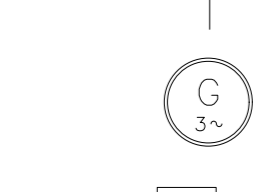
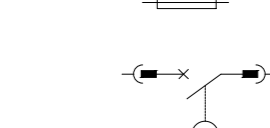
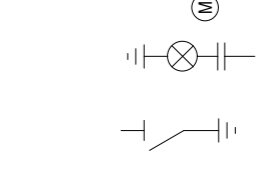
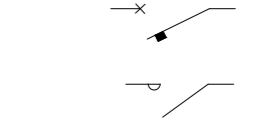
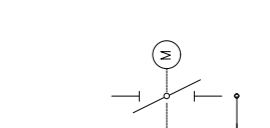
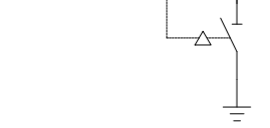
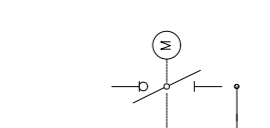
<p>PROPRONTE</p>  <p>LUCANIA PRIME S.R.L. Via A. De Gasperi n.8 74023 Grottaglie (TA)</p>	<p>CONSULENZA</p>  <p>GE.CO.D'OR S.R.L. Via A. De Gasperi n.8 74023 Grottaglie (TA)</p> <p>PROGETTISTA Ing. Gaetano D'Oronzio Via Goito 14 - Colobraro (MT)</p>
--	---

IMPIANTO BESS (BATTERY ENERGY STORAGE SYSTEM)

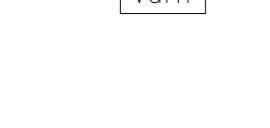
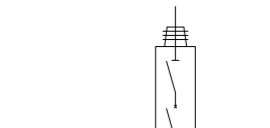
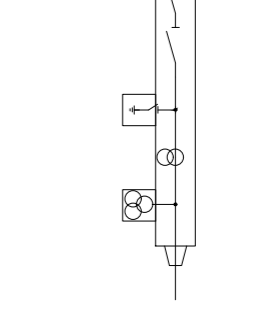
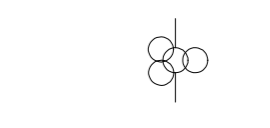
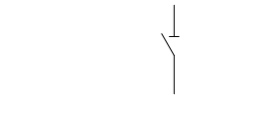
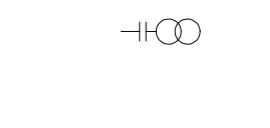
LEGENDA

-  INTERRUTTORE AT CON COMANDO MOTORIZZATO
-  SEZIONATORE MANUALE AT CON INTERBLOCCO LAME DI TERRA
-  SEZIONATORE MOTORIZZATO ROTATIVO AT CON INTERBLOCCO LAME DI TERRA
-  SCARICATORE
-  TRASFORMATORE DI TENSIONE
-  TRASFORMATORE DI CORRENTE
-  TRASFORMATORE DI POTENZA (COMMUTATORE SOTTO CARICO MOTORIZZATO)
-  TRASFORMATORE SERVIZI AUSILIARI
-  GENERATORE ASINCRONO
-  FUSIBILE
-  INTERRUTTORE MT ASPORTABILE CON COMANDO MOTORIZZATO
-  INDICATORE CAPACITIVO PRESENZA TENSIONE
-  LAME DI MESSA A TERRA
-  INTERRUTTORE AUTOMATICO
-  CONTATORE DI MANOVRA
-  SEZIONATORE ROTATIVO CON MESSA A TERRA
-  SEZIONATORE ROTATIVO SOTTOCARICO CON MESSA A TERRA
-  LAMPADA DI SEGNALAZIONE
-  BLOCCO A CHIAVE, CHIAVE LIBERA IN APERTO
-  BLOCCO A CHIAVE, CHIAVE LIBERA IN CHIUSO
-  CONTATORE DI ENERGIA ATTIVA/REATTIVA ENTRANTE-USCENTE PER MISURE FISCALI
-  MODULO IBRIDO 150 kV (Maggiori dettagli sono riportati nell'elaborato "GEOE083 Relazione tecnica descrittiva connessione RTN Tema")
-  TA A 3 NUCLEI
-  SEZIONATORE
-  TV CAPACITIVO
-  TERMINALE ARIA - CAVO

Linea BESS AUX (33 kV)

Linea BESS (33 kV)

ARP1H5(AR)E P-Laser AIR BAG™

BESS 1.1

BESS 1.2

BESS 1.3

41 m 3x(1x185)mm²

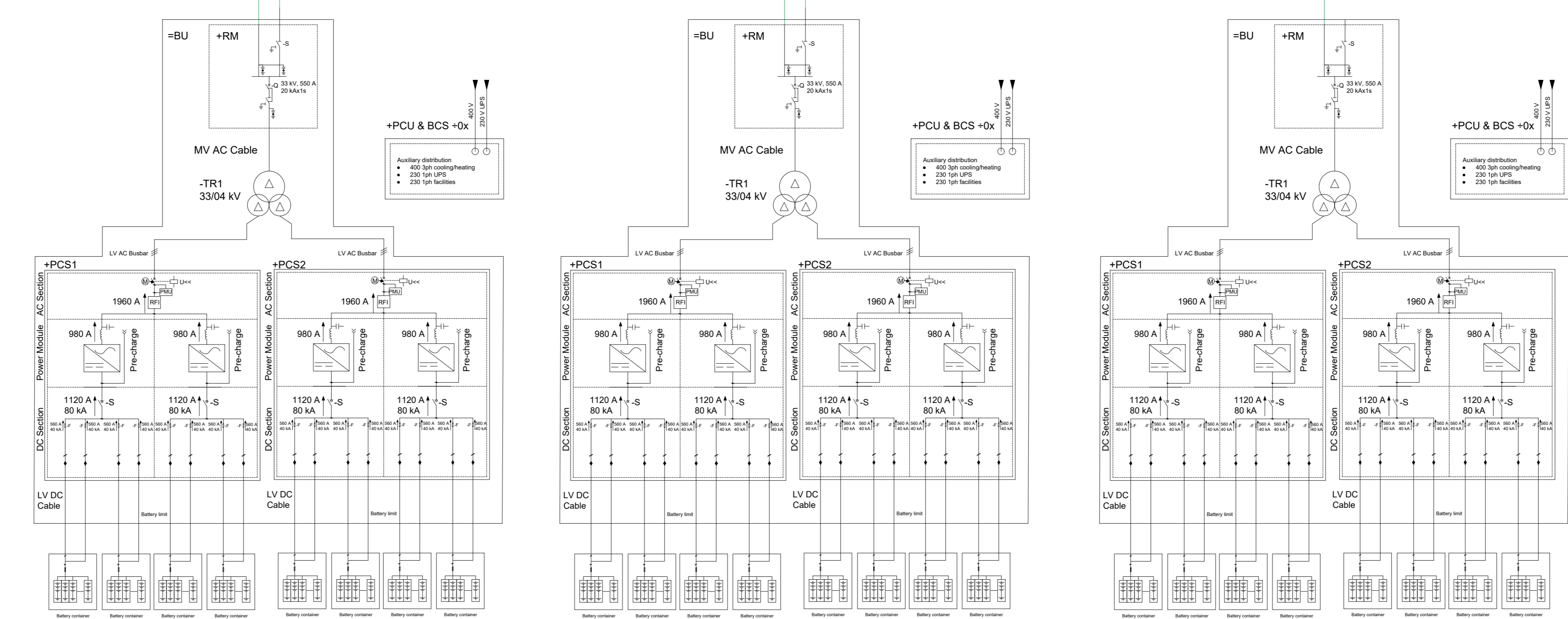

BESS AUX

ARP1H5(AR)E P-Laser AIR BAG™

BESS AUX 1

65 m 3x(1x50)mm²

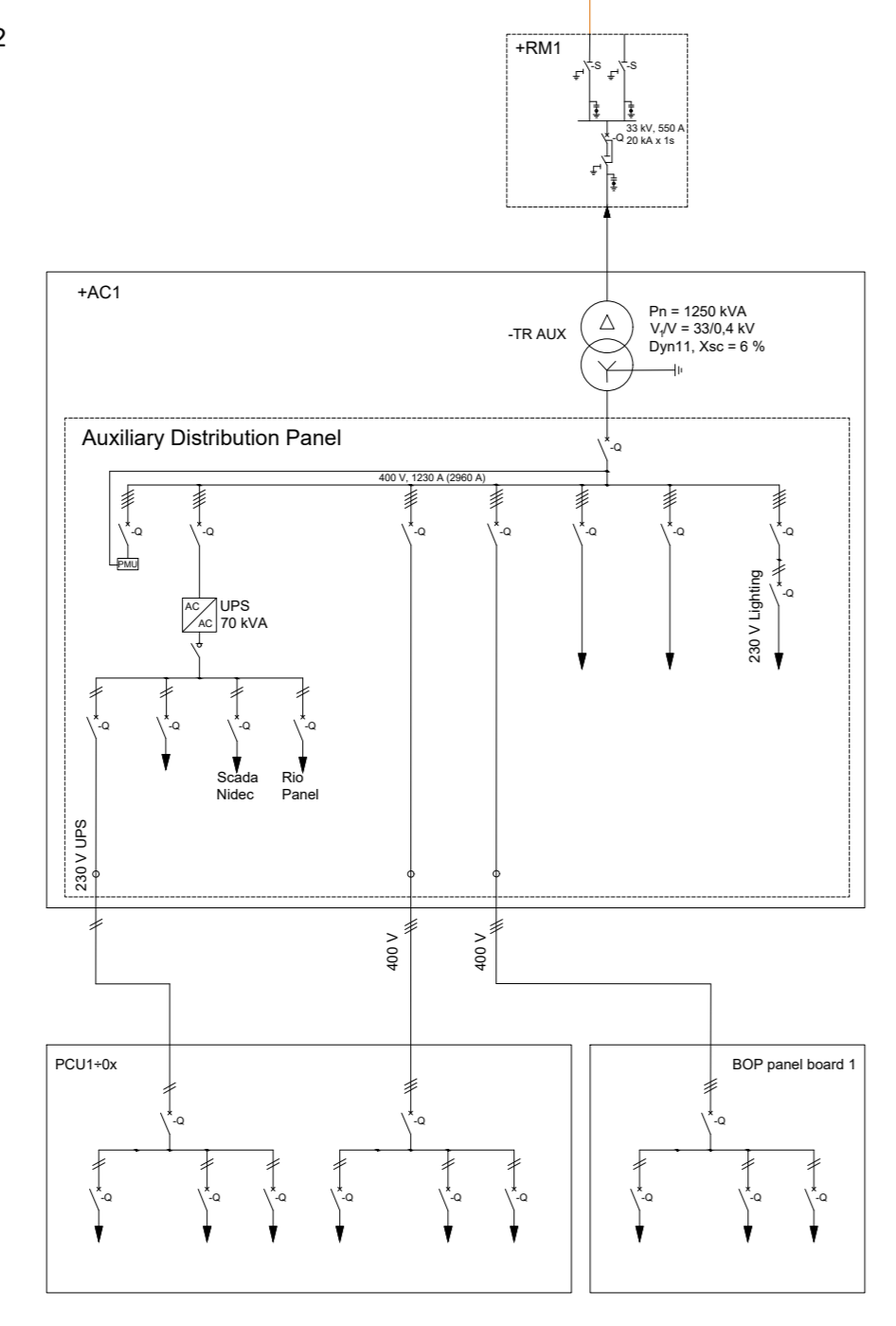

AUTORIZZAZIONE UNICA EX D. LGS. N. 387/2003



PROGETTO DEFINITIVO
PARCO EOLICO GENZANO







Titolo elaborato:

SCHEMA ELETTRICO UNIFILARE DEGLI IMPIANTI DI UTENTE E DI RTN (LIMITATAMENTE ALLO STALLO DI COMPETENZA)

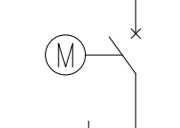
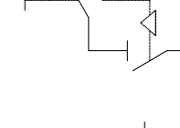
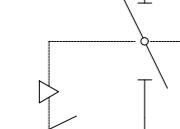
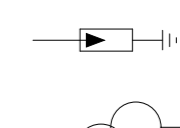
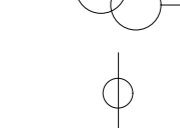
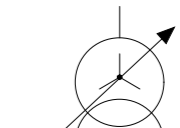
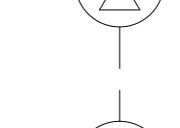
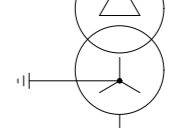
SS	LT	GD	Prima emissione	04/08/2023	00
REDDATTO	CONTR.	APPROV.	DESCRIZIONE REVISIONE DOCUMENTO	DATA	REV

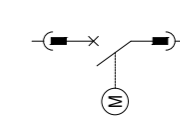
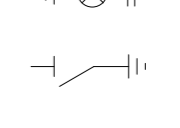
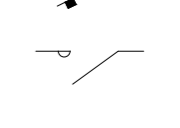
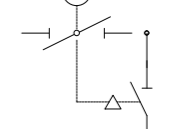
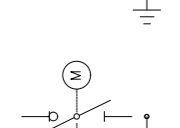
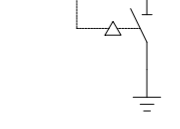
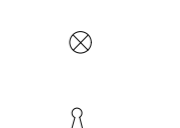
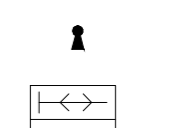
<p>PROPRONTE</p>  <p>LUCANIA PRIME S.R.L. Via A. De Gasperi n.8 74023 Grottaglie (TA)</p>	<p>CONSULENZA</p>  <p>GE.CO.D'OR. S.R.L. Via A. De Gasperi n.8 74023 Grottaglie (TA)</p> <p>PROGETTISTA Ing. Gaetano D'Oronzio Via Goito 14 - Colobraro (MT)</p>
--	--

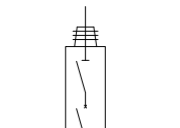
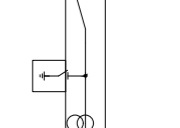
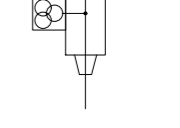
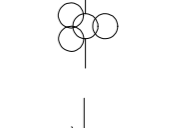
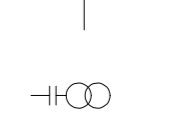
LEGENDA

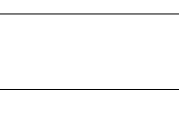
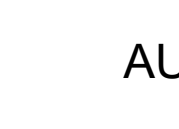
-  INTERRUTTORE AT CON COMANDO MOTORIZZATO
-  SEZIONATORE MANUALE AT CON INTERBLOCCO LAME DI TERRA
-  SEZIONATORE MOTORIZZATO ROTATIVO AT CON INTERBLOCCO LAME DI TERRA
-  SCARICATORE
-  TRASFORMATORE DI TENSIONE
-  TRASFORMATORE DI CORRENTE
-  TRASFORMATORE DI POTENZA (COMMUTATORE SOTTO CARICO MOTORIZZATO)
-  TRASFORMATORE SERVIZI AUSILIARI
-  GENERATORE ASINCRONO
-  FUSIBILE
-  INTERRUTTORE MT ASPORTABILE CON COMANDO MOTORIZZATO
-  INDICATORE CAPACITIVO PRESENZA TENSIONE
-  LAME DI MESSA A TERRA
-  INTERRUTTORE AUTOMATICO
-  CONTATORE DI MANOVRA
-  SEZIONATORE ROTATIVO CON MESSA A TERRA
-  SEZIONATORE ROTATIVO SOTTOCARICO CON MESSA A TERRA
-  LAMPADA DI SEGNALAZIONE
-  BLOCCO A CHIAVE, CHIAVE LIBERA IN APERTO
-  BLOCCO A CHIAVE, CHIAVE LIBERA IN CHIUSO
-  CONTATORE DI ENERGIA ATTIVA/REATTIVA ENTRANTE-USCENTE PER MISURE FISCALI
-  MODULO IBRIDO 150 kV (Maggiori dettagli sono riportati nell'elaborato "GEOE083 Relazione tecnica descrittiva connessione RTN Tema")
-  TA A 3 NUCLEI
-  SEZIONATORE
-  TV CAPACITIVO
-  TERMINALE ARIA - CAVO

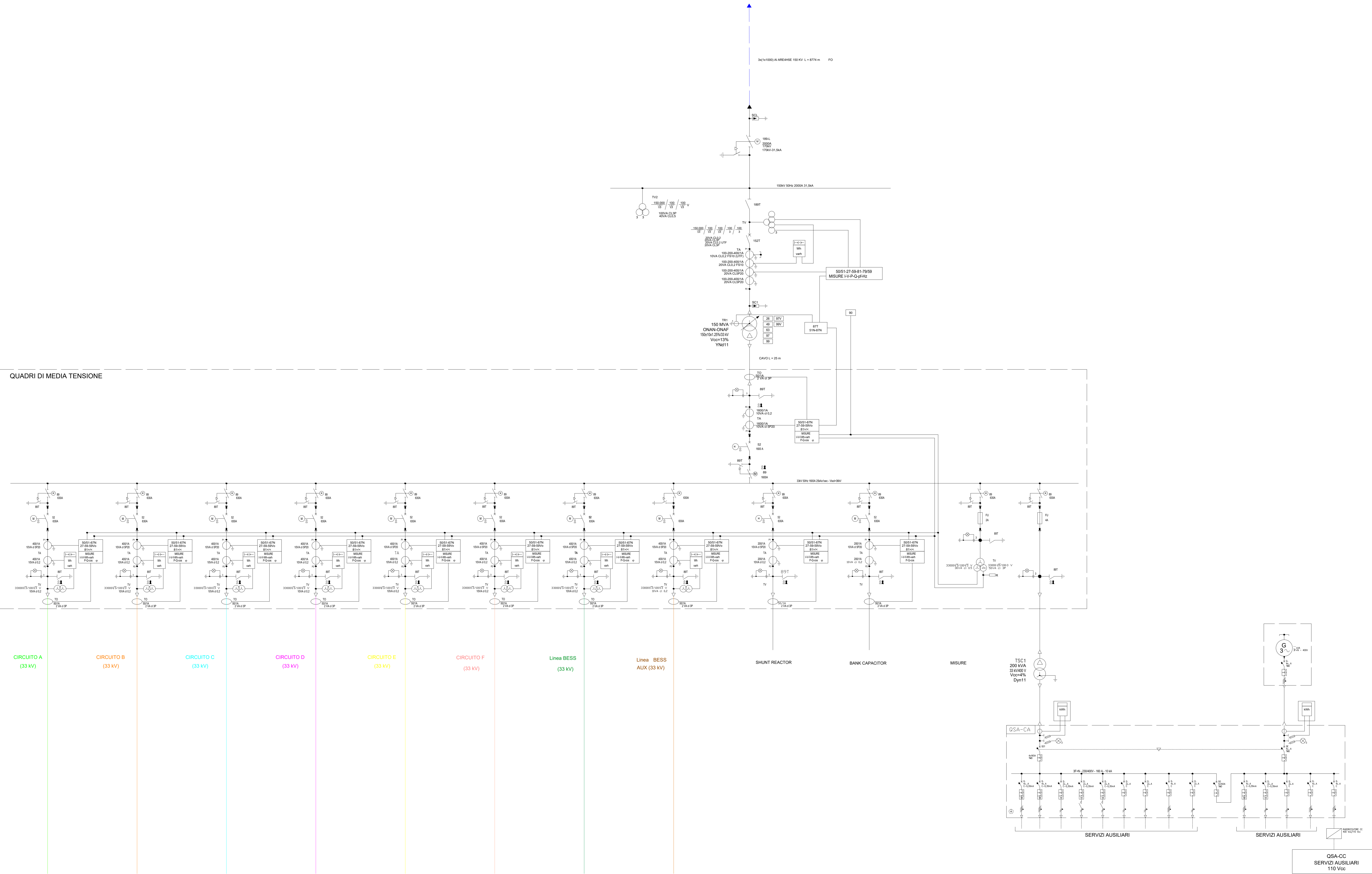

QUADRI DI MEDIA TENSIONE

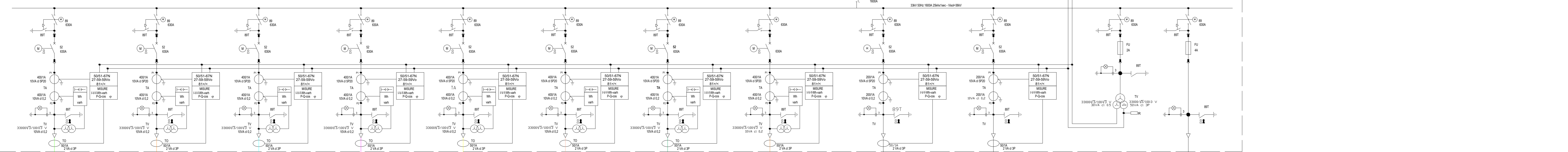

- CIRCUITO A (33 kV)
- CIRCUITO B (33 kV)
- CIRCUITO C (33 kV)
- CIRCUITO D (33 kV)
- CIRCUITO E (33 kV)
- CIRCUITO F (33 kV)
- Linea BESS (33 kV)
- Linea BESS AUX (33 kV)
- SHUNT REACTOR
- BANK CAPACITOR
- MISURE
- TSC1 200 kVA 21 kV/0.1 V_{oc} 4% Dyn11
- DSA-CA
- SERVIZI AUSILIARI
- SERVIZI AUSILIARI
- OSA-CC SERVIZI AUSILIARI 110 Vcc

AUTORIZZAZIONE UNICA EX D. LGS. N. 387/2003

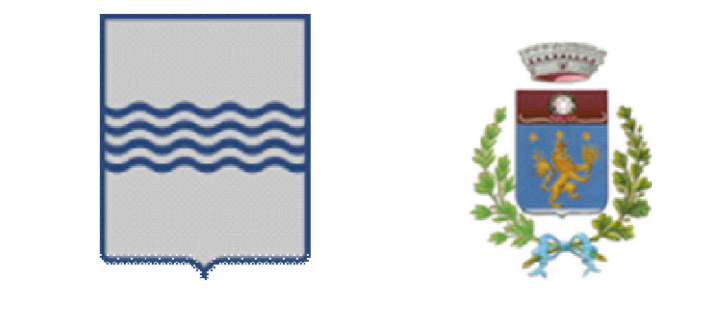







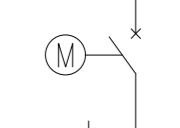
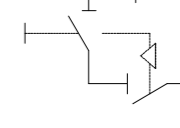
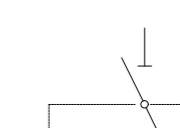
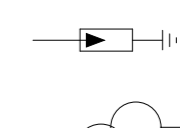
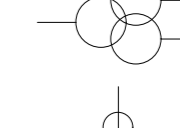
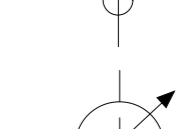

PROGETTO DEFINITIVO
PARCO EOLICO GENZANO

Titolo elaborato:
SCHEMA ELETTRICO UNIFILARE DEGLI IMPIANTI DI UTENTE E DI RTN (LIMITATAMENTE ALLO STALLO DI COMPETENZA)

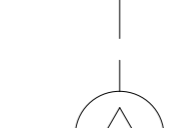
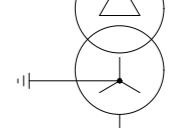
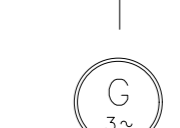
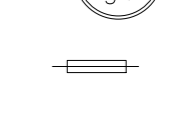
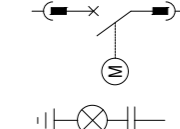
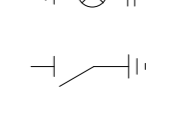
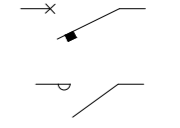
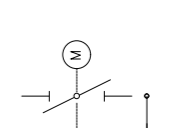
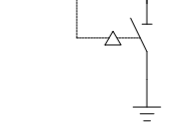
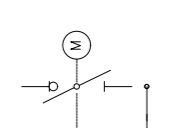
SS	LT	GD	Prima emissione	04/08/2023	00
REDDATTO	CONTR.	APPROV.	DESCRIZIONE REVISIONE DOCUMENTO	DATA	REV

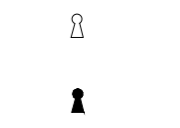
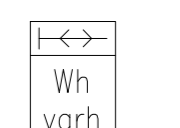
<p>PROPRONTE</p>  <p>LUCANIA PRIME S.R.L. Via A. De Gasperi n.8 74023 Grottaglie (TA)</p>	<p>CONSULENZA</p>  <p>GE.CO.D'OR S.R.L. Via A. De Gasperi n.8 74023 Grottaglie (TA)</p> <p>PROGETTISTA Ing. Gaetano D'Oronzio Via Goito 14 - Colobraro (MT)</p>
--	---

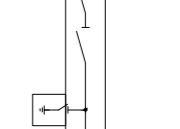
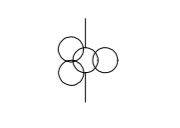
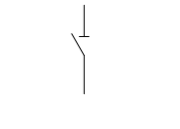
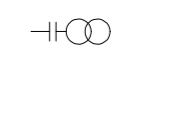
LEGENDA

-  INTERRUTTORE AT CON COMANDO MOTORIZZATO
-  SEZIONATORE MANUALE AT CON INTERBLOCCO LAME DI TERRA
-  SEZIONATORE MOTORIZZATO ROTATIVO AT CON INTERBLOCCO LAME DI TERRA
-  SCARICATORE
-  TRASFORMATORE DI TENSIONE
-  TRASFORMATORE DI CORRENTE
-  TRASFORMATORE DI POTENZA (COMMUTATORE SOTTO CARICO MOTORIZZATO)
-  TRASFORMATORE SERVIZI AUSILIARI
-  GENERATORE ASINCRONO
-  FUSIBILE
-  INTERRUTTORE MT ASPORTABILE CON COMANDO MOTORIZZATO
-  INDICATORE CAPACITIVO PRESENZA TENSIONE
-  LAME DI MESSA A TERRA
-  INTERRUTTORE AUTOMATICO
-  CONTATORE DI MANOVRA
-  SEZIONATORE ROTATIVO CON MESSA A TERRA
-  SEZIONATORE ROTATIVO SOTTOCARICO CON MESSA A TERRA
-  LAMPADA DI SEGNALAZIONE
-  BLOCCO A CHIAVE, CHIAVE LIBERA IN APERTO
-  BLOCCO A CHIAVE, CHIAVE LIBERA IN CHIUSO
-  CONTATORE DI ENERGIA ATTIVA/REATTIVA ENTRANTE-USCENTE PER MISURE FISCALI
-  MODULO IBRIDO 150 kV (Maggiori dettagli sono riportati nell'elaborato "GEOE083 Relazione tecnica descrittiva connessione RTN Terna")
-  TA A 3 NUCLEI
-  SEZIONATORE
-  TV CAPACITIVO
-  TERMINALE ARIA - CAVO

Ampliamento SE RTN 380/150 kV "Genzano"

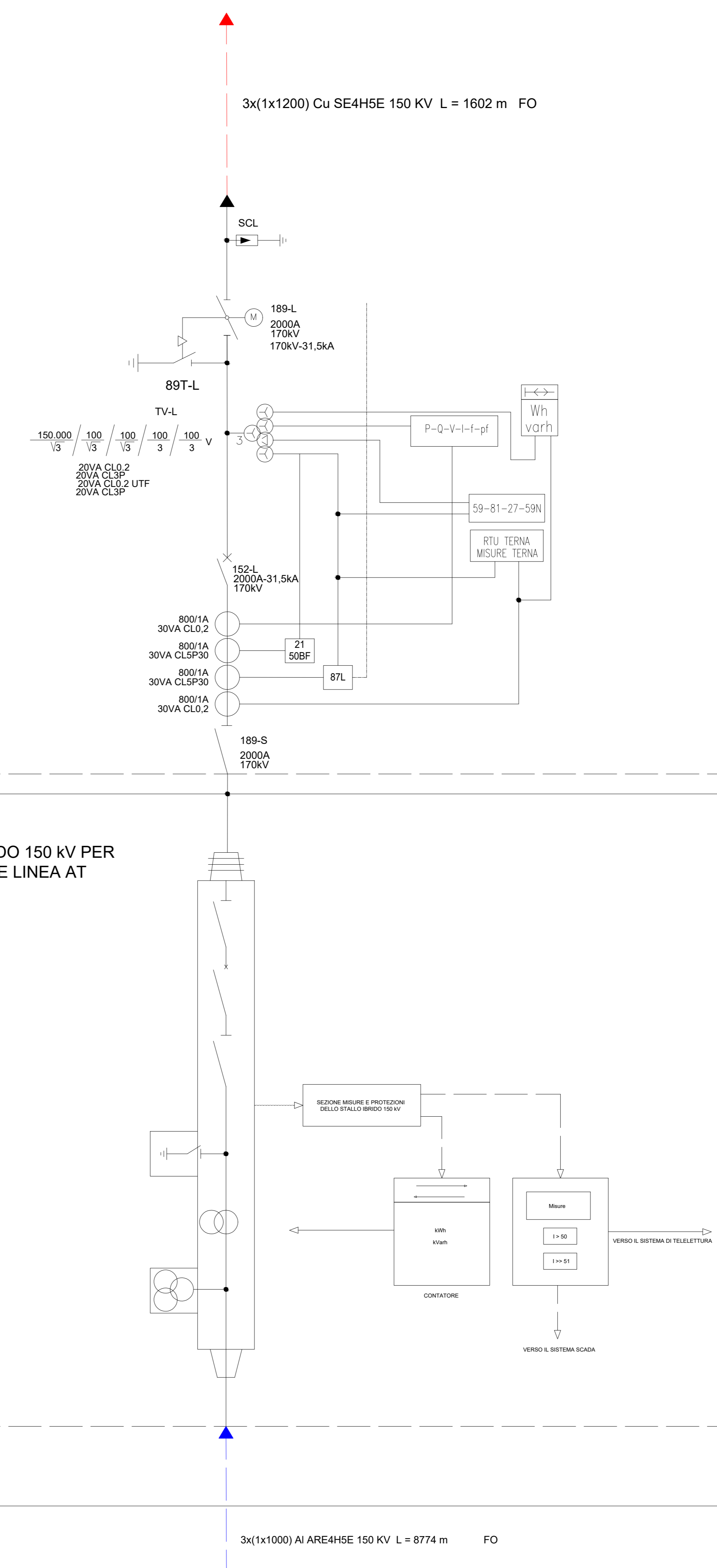

STAZIONE CONDIVISA

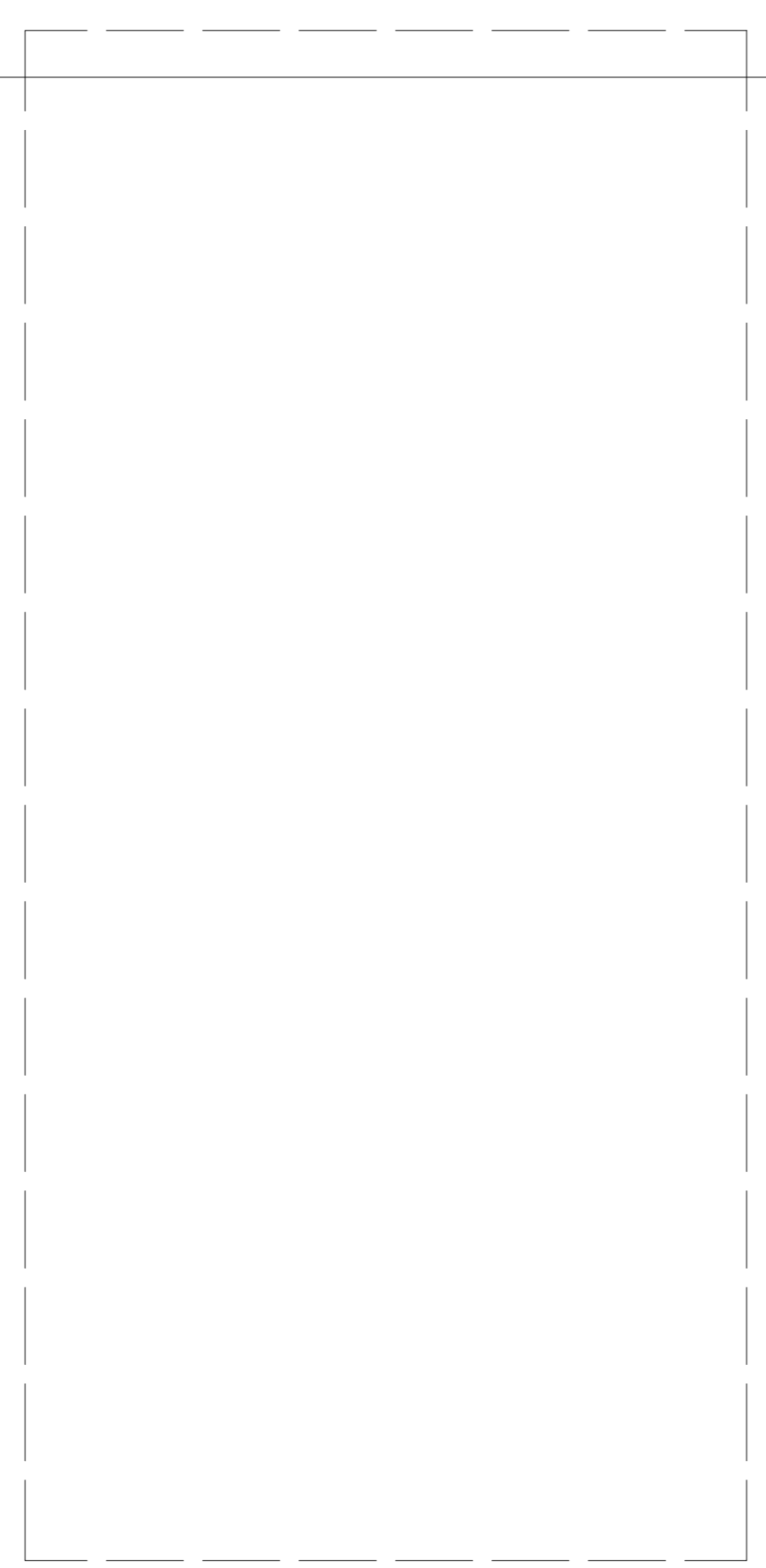

ALTRO PRODUTTORE

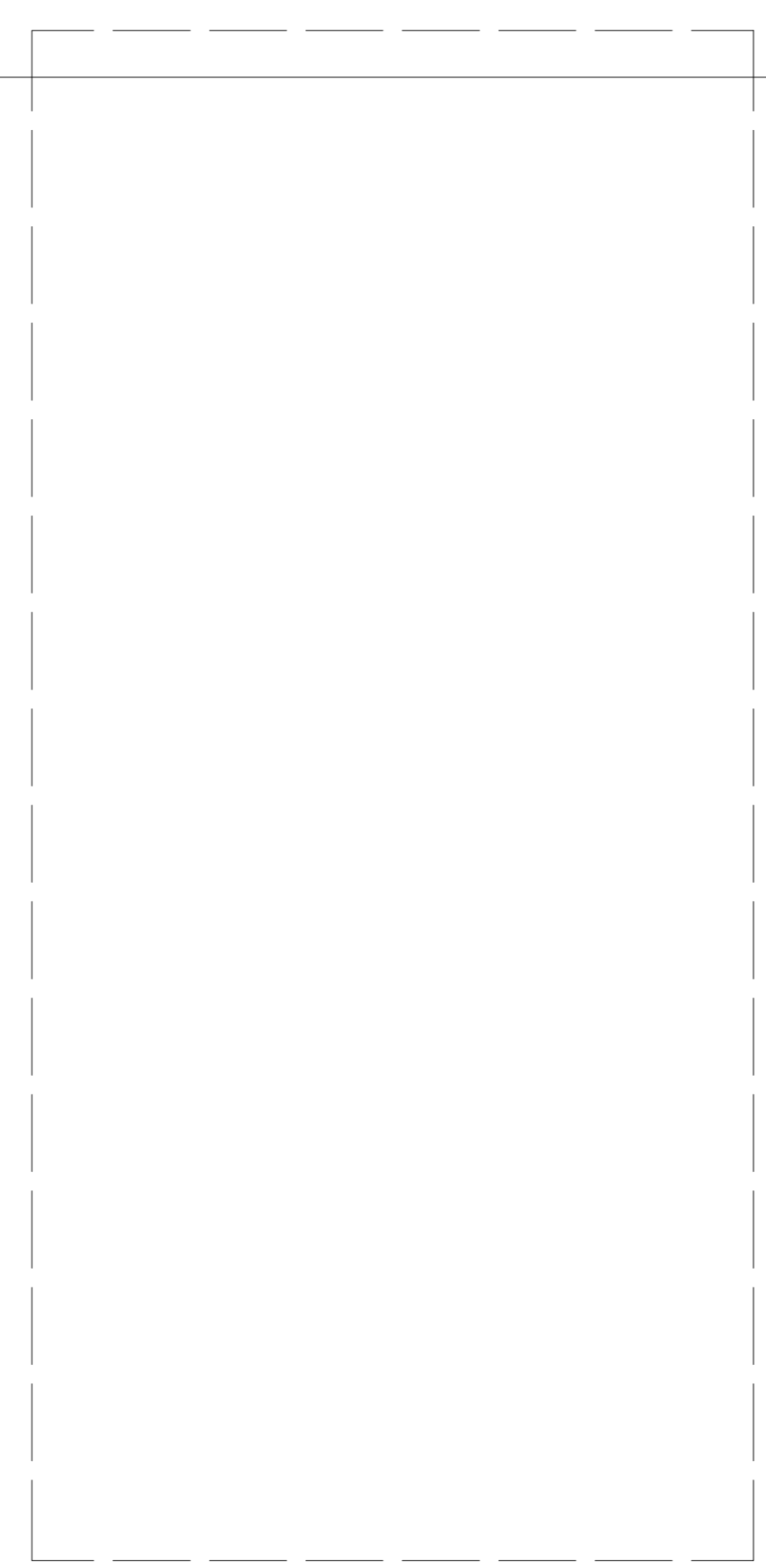

ALTRO PRODUTTORE

AUTORIZZAZIONE UNICA EX D. LGS. N. 387/2003



**PROGETTO DEFINITIVO
PARCO EOLICO GENZANO**

Titolo elaborato:

**SCHEMA ELETTRICO UNIFILARE DEGLI IMPIANTI DI UTENTE
E DI RTN (LIMITATAMENTE ALLO STALLO DI COMPETENZA)**

SS	LT	GD	Prima emissione	04/08/2023	00
REDDATTO	CONTR.	APPROV.	DESCRIZIONE REVISIONE DOCUMENTO	DATA	REV

PROPONENTE



LUCANIA PRIME S.R.L.
Via A. De Gasperi n.8
74023 Grottaglie (TA)

CONSULENZA





GE.CO.D'OR S.R.L.
Via A. De Gasperi n.8
74023 Grottaglie (TA)

PROGETTISTA
Ing. Gaetano D'Oronzio
Via Goito 14 - Colobraro (MT)

Codice GEOE094	Formato A0	Scala -	Foglio 5/6
-------------------	---------------	------------	---------------

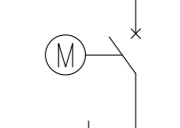
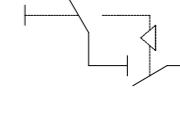
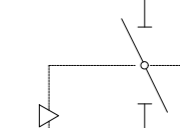
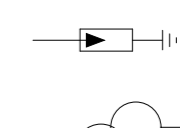
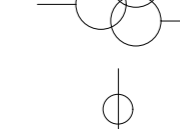
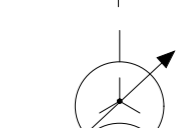
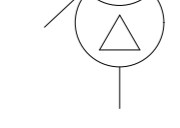
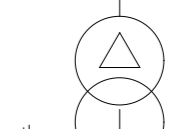
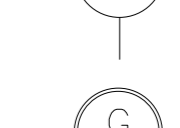
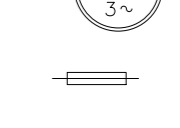
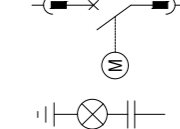
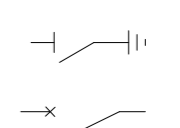
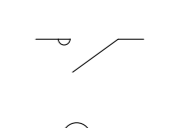
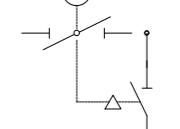
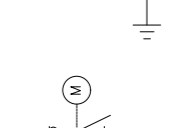
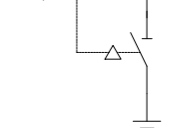
LEGENDA

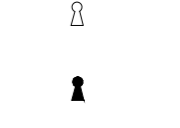
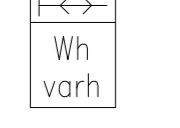
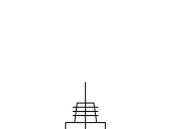
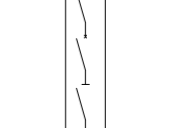
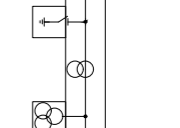
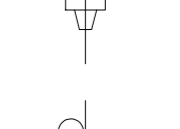
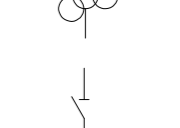
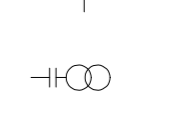
-  INTERRUTTORE AT CON COMANDO MOTORIZZATO
-  SEZIONATORE MANUALE AT CON INTERBLOCCO LAME DI TERRA
-  SEZIONATORE MOTORIZZATO ROTATIVO AT CON INTERBLOCCO LAME DI TERRA
-  SCARICATORE
-  TRASFORMATORE DI TENSIONE
-  TRASFORMATORE DI CORRENTE
-  TRASFORMATORE DI POTENZA (COMMUTATORE SOTTO CARICO MOTORIZZATO)
-  TRASFORMATORE SERVIZI AUSILIARI
-  GENERATORE ASINCRONO
-  FUSIBILE
-  INTERRUTTORE MT ASPORTABILE CON COMANDO MOTORIZZATO
-  INDICATORE CAPACITIVO PRESENZA TENSIONE
-  INTERRUTTORE AUTOMATICO
-  CONTATORE DI MANOVRA
-  SEZIONATORE ROTATIVO CON MESSA A TERRA
-  SEZIONATORE ROTATIVO SOTTOCARICO CON MESSA A TERRA
-  LAMPADA DI SEGNALAZIONE
-  BLOCCO A CHIAVE, CHIAVE LIBERA IN APERTO
-  BLOCCO A CHIAVE, CHIAVE LIBERA IN CHIUSO
-  CONTATORE DI ENERGIA ATTIVA/REATTIVA ENTRANTE-USCENTE PER MISURE FISCALI
-  MODULO IBRIDO 150 kV (Maggiori dettagli sono riportati nell'elaborato "GEOE083 Relazione tecnica descrittiva connessione RTN Tema")
-  TA A 3 NUCLEI
-  SEZIONATORE
-  TV CAPACITIVO
-  TERMINALE ARIA - CAVO

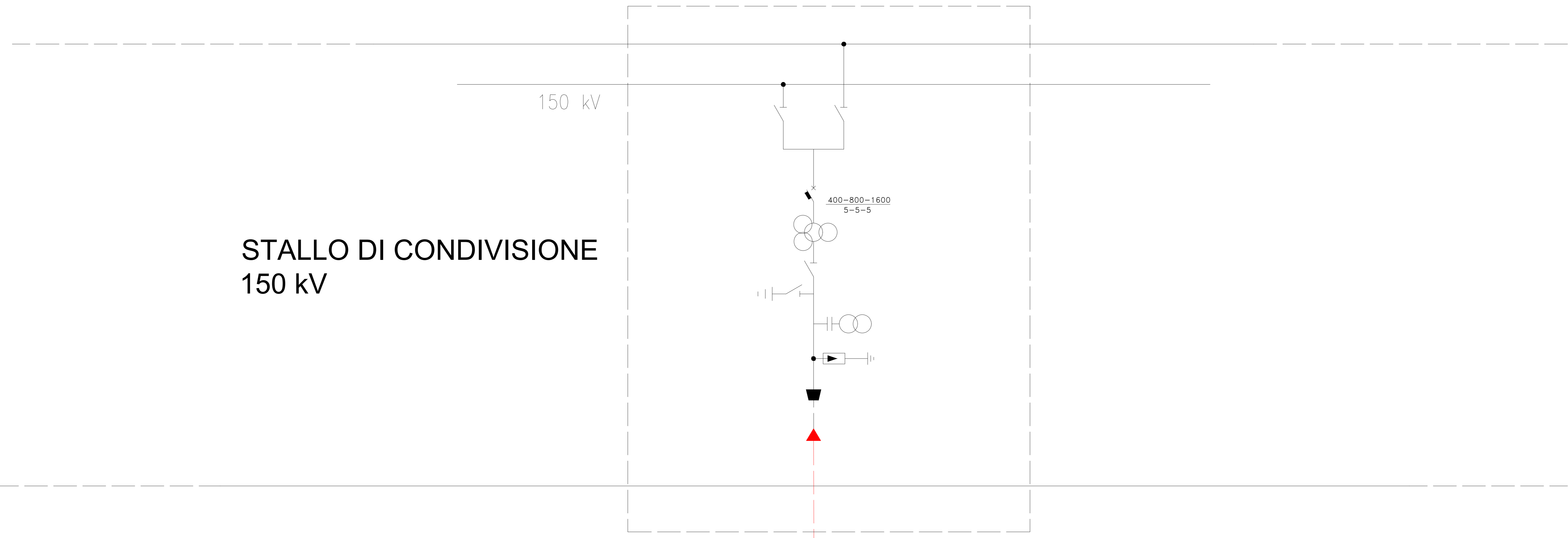

Ampliamento della SE RTN 380/150 kV "Genzano"

AUTORIZZAZIONE UNICA EX D. LGS. N. 387/2003



**PROGETTO DEFINITIVO
PARCO EOLICO GENZANO**

Titolo elaborato:

**SCHEMA ELETTRICO UNIFILARE DEGLI IMPIANTI DI UTENTE
E DI RTN (LIMITATAMENTE ALLO STALLO DI COMPETENZA)**

SS	LT	GD	Prima emissione	04/08/2023	00
REDDATTO	CONTR.	APPROV.	DESCRIZIONE REVISIONE DOCUMENTO	DATA	REV

PROPONENTE



LUCANIA PRIME S.R.L.
Via A. De Gasperi n.8
74023 Grottaglie (TA)

CONSULENZA



GE.CO.D'OR S.R.L.
Via A. De Gasperi n.8
74023 Grottaglie (TA)

PROGETTISTA
Ing. Gaetano D'Oronzio
Via Goito 14 - Colobraro (MT)

Codice GEOE094	Formato A0	Scala -	Foglio 6/6
-------------------	---------------	------------	---------------