

**CARPENTERIA CENTINA - TIPO A6**  
SCALA 1:25

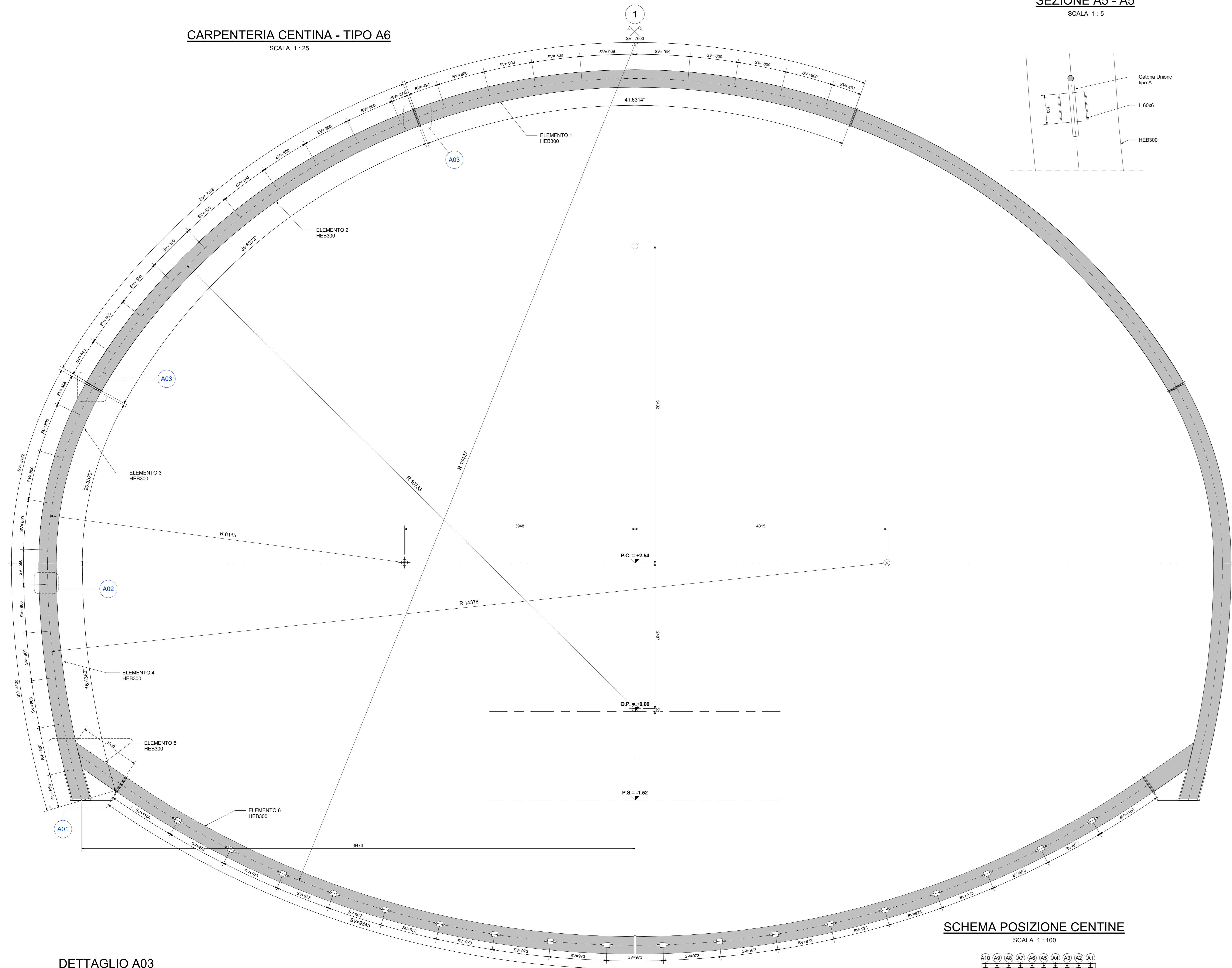

**SEZIONE A5 - A5**  
SCALA 1:5

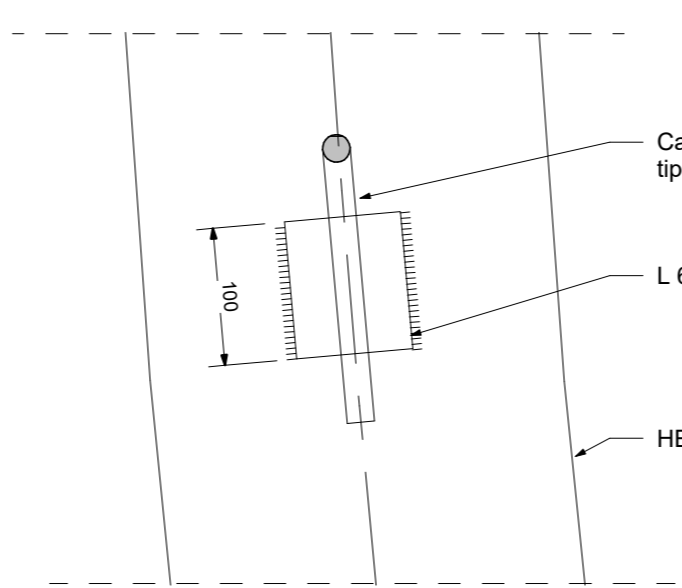

**DETTAGLIO A02**  
SCALA 1:5  
UNIONE CENTINE

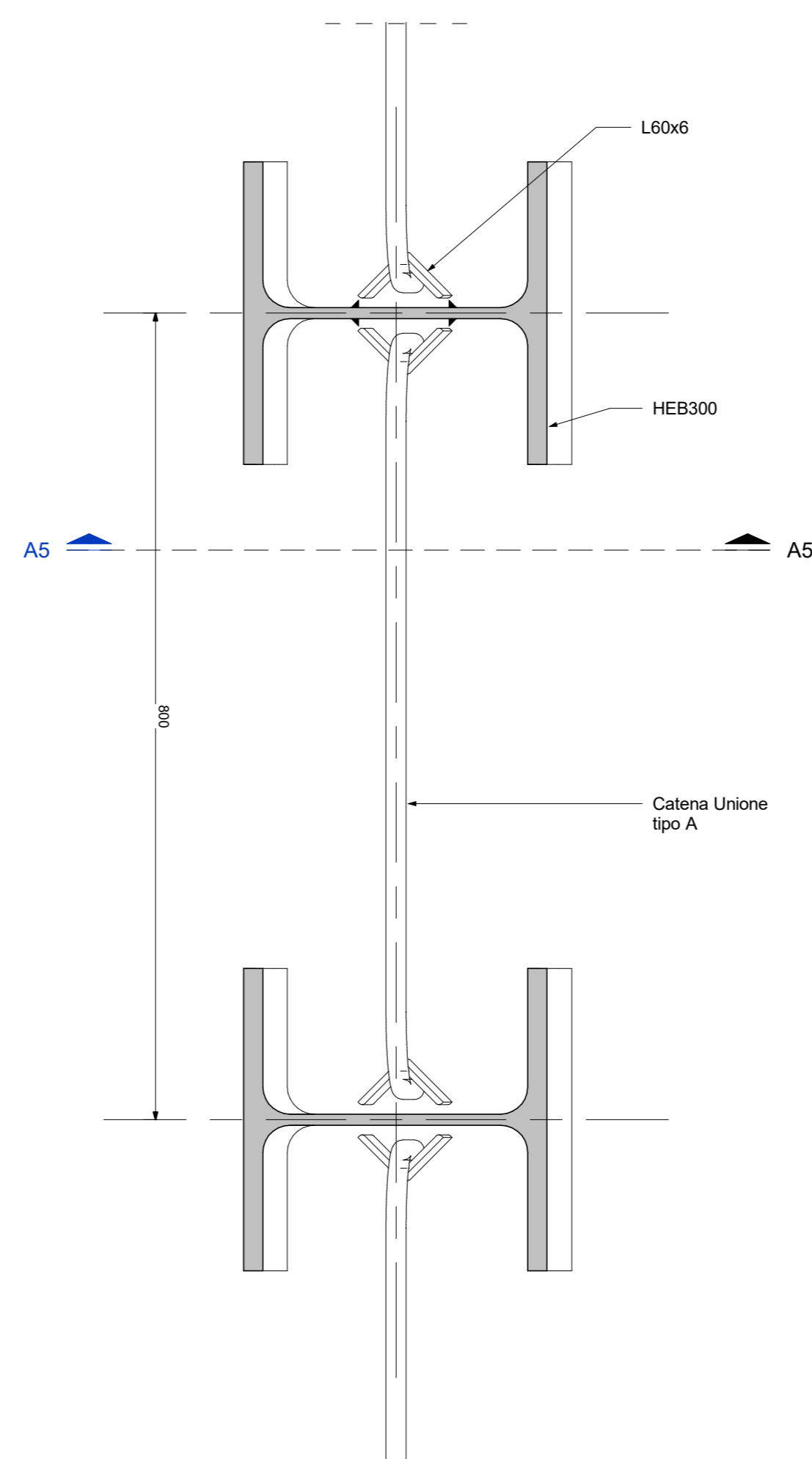

**SEZIONE A1 - A1**  
SCALA 1:5

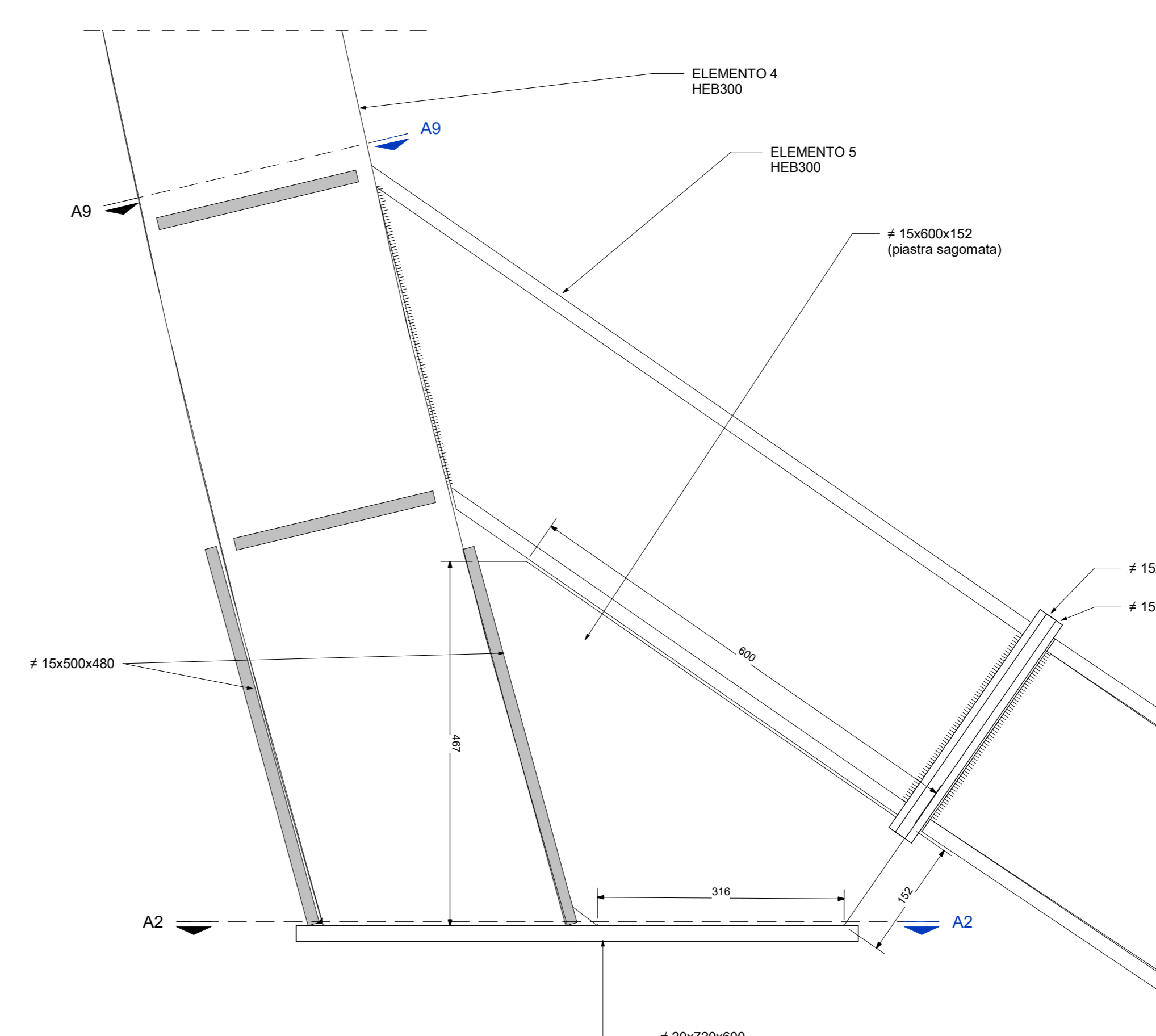

**DETTAGLIO A01**  
SCALA 1:5

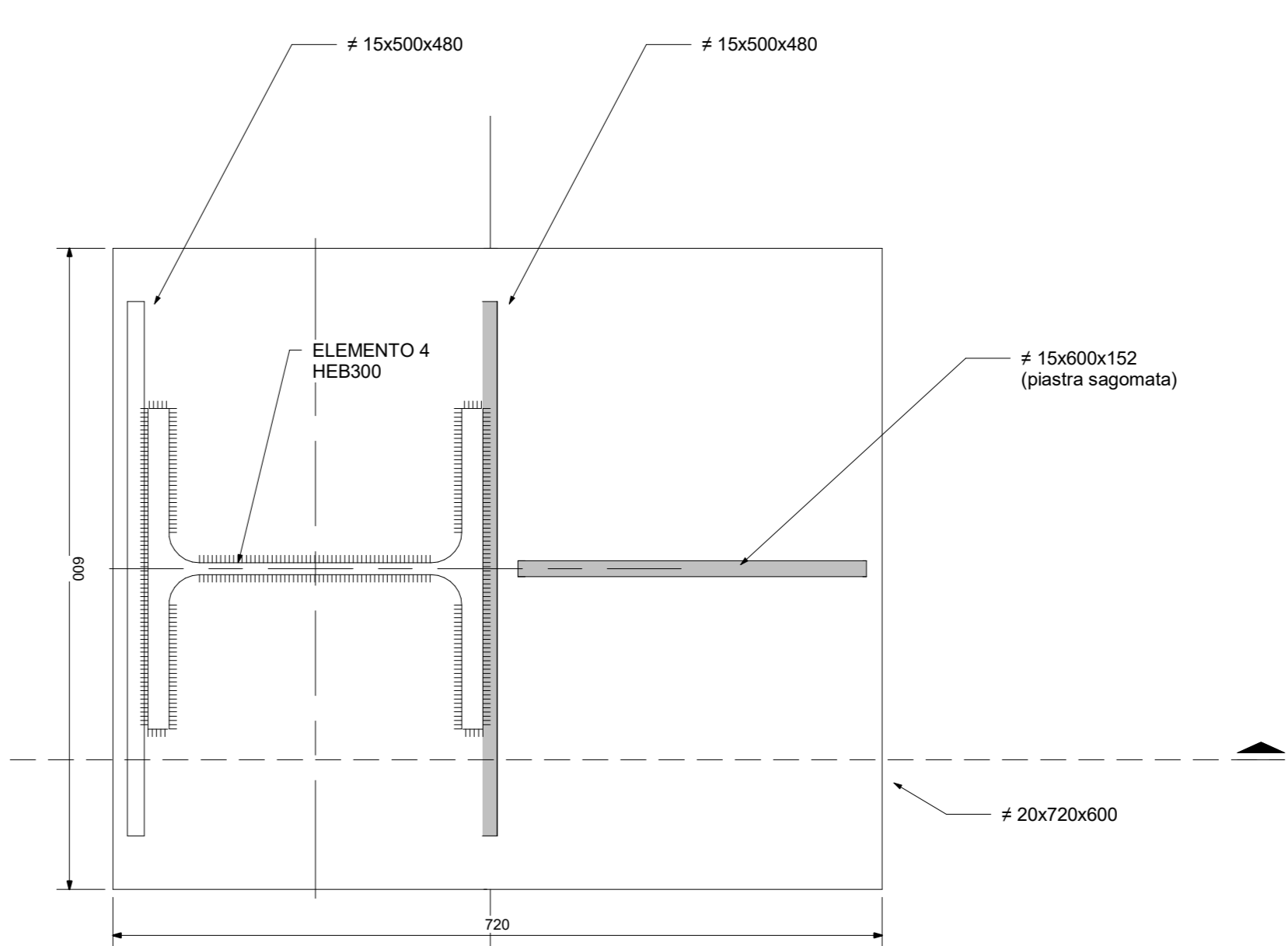

**DETTAGLIO CATENA UNIONE**  
SCALA 1:5

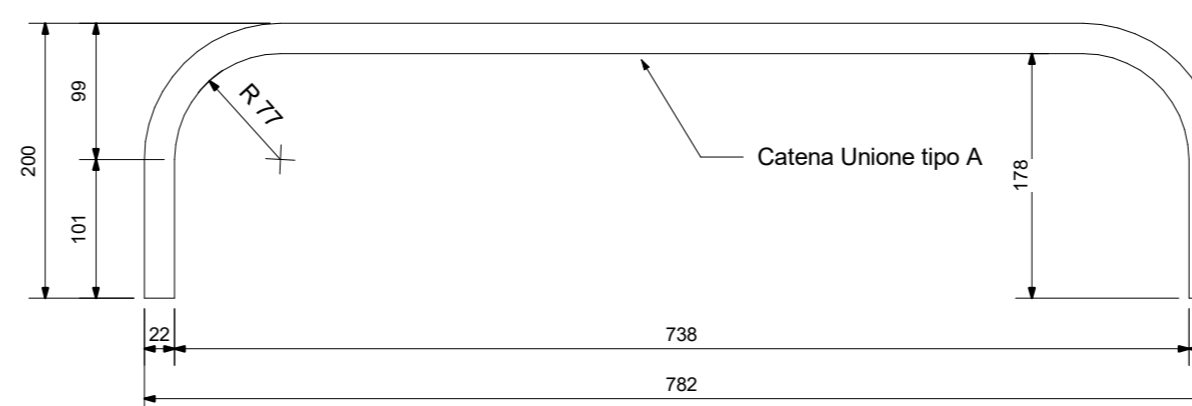

**VISTA 3D**

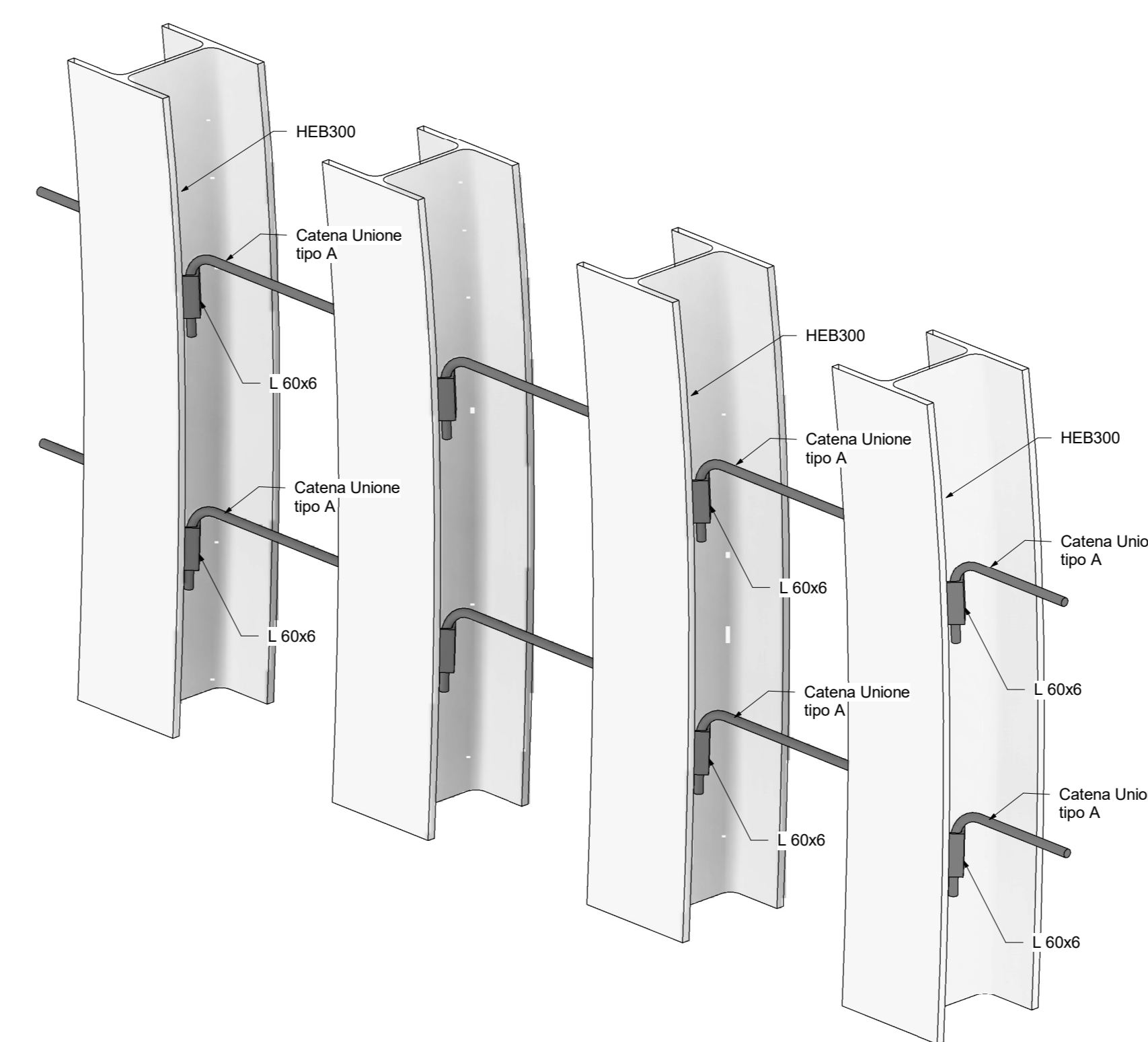

**VISTA 3D**

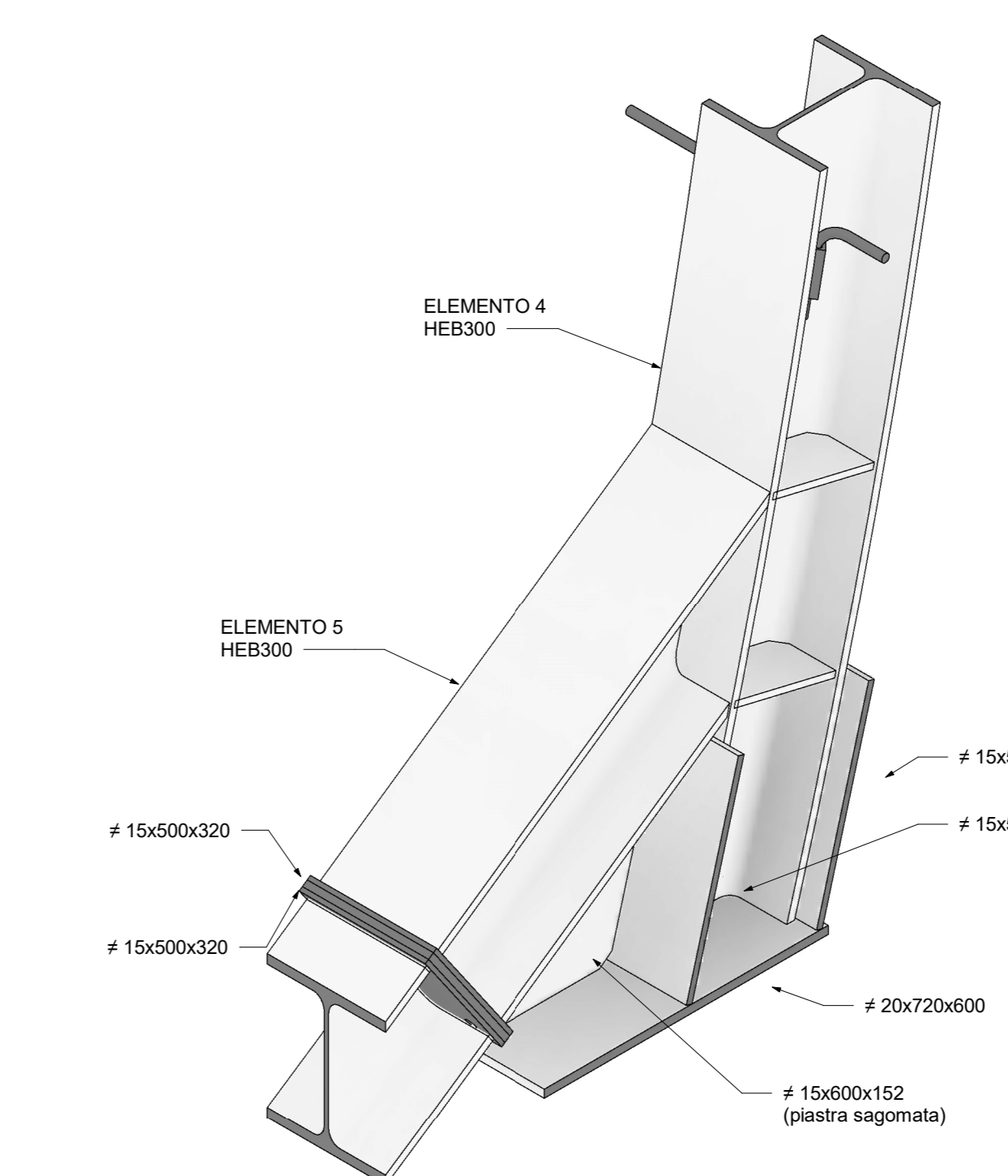

**SCHEMA POSIZIONE CENTINE**  
SCALA 1:100

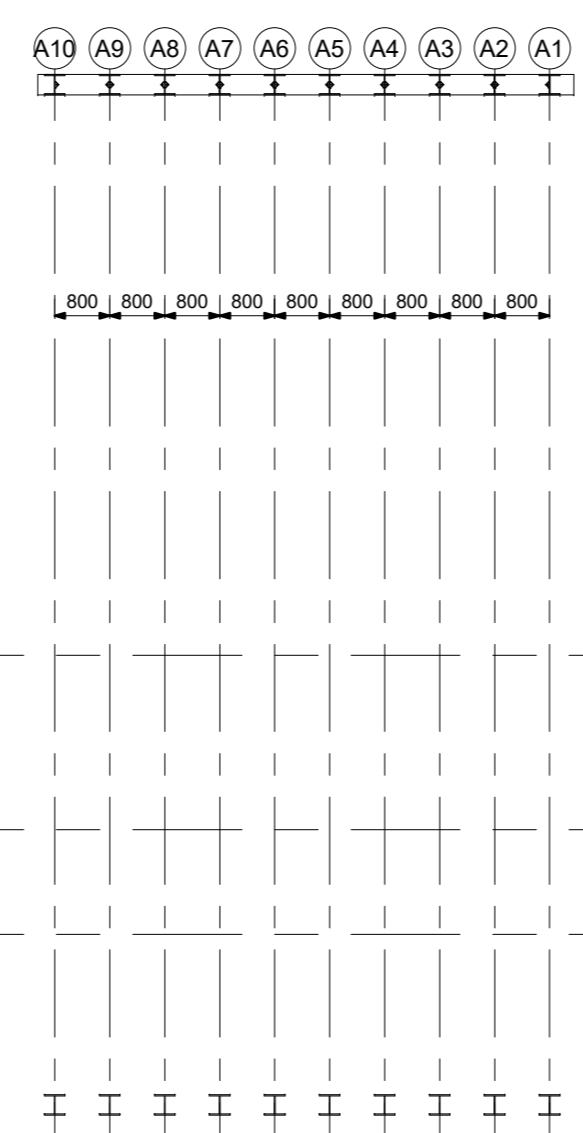

**SEZIONE A9 - A9**  
SCALA 1:5

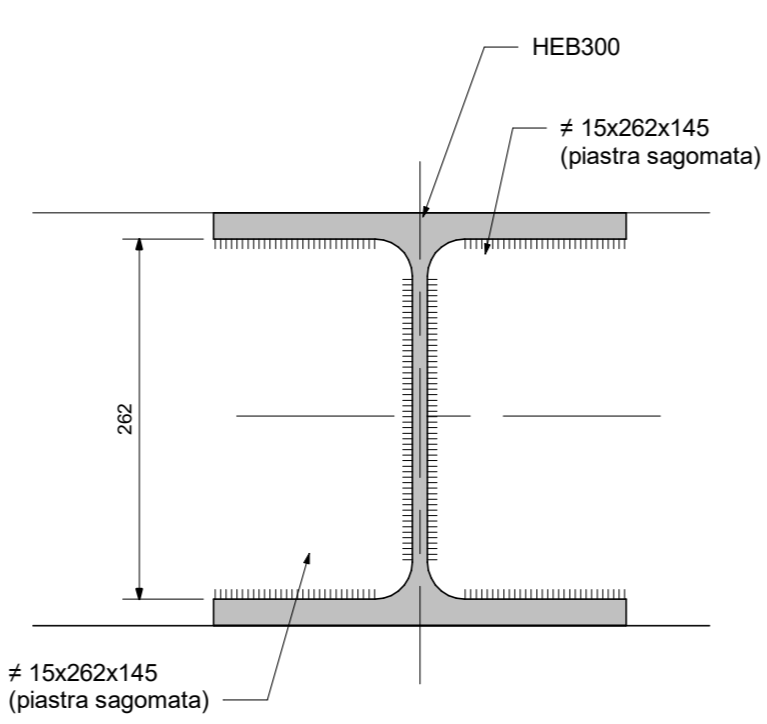

**SEZIONE A4 - A4**  
SCALA 1:5

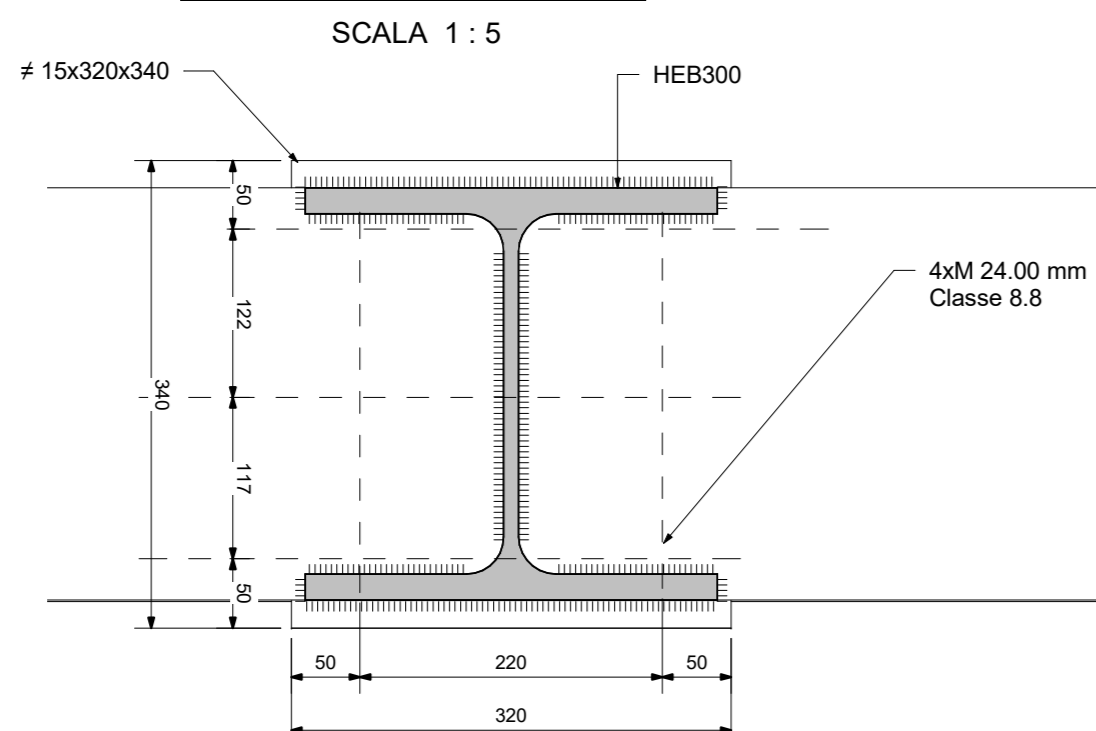

**DETTAGLIO A03**  
SCALA 1:5

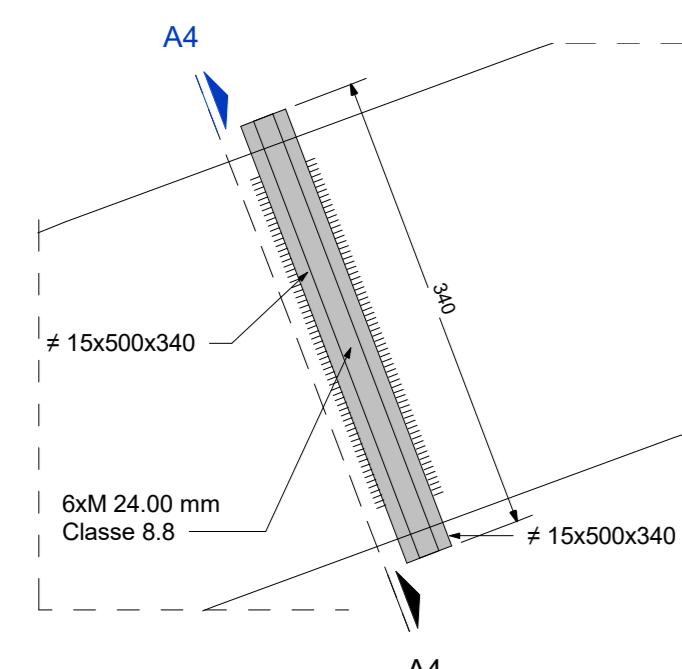

**ELENCO ELABORATI DI RIFERIMENTO**

IF3A02EZZB8GN0200005	Scavi e consolidamenti -fase di avanzamento- campo 1
IF3A02EZZB8GN0200006	Scavi e consolidamenti -fase di avanzamento- campo 2
IF3A02EZZB8GN0200007	Scavi e consolidamenti -fase di avanzamento- campo 3
IF3A02EZZB8GN0200008	Scavi e consolidamenti -fase di avanzamento- campo 4
IF3A02EZZB8GN0200009	Scavi e consolidamenti -fase di avanzamento- campo 5
IF3A02EZZB8GN0200010	Campo 1 - Centina - carpenteria
IF3A02EZZB8GN0200011	Campo 2 - Centina - carpenteria
IF3A02EZZB8GN0200012	Campo 3 - Centina - carpenteria
IF3A02EZZB8GN0200013	Campo 4 - Centina - carpenteria
IF3A02EZZB8GN0200014	Campo 5 - Centina - carpenteria

**NOTE**

- LA TABELLA MATERIALI E' RIPORTATA IN UNO SPECIFICO ELABORATO.
- LE MISURE SONO ESPRESSE IN MILLIMETRI.
- LE MISURE E GLI SVILUPPI DELLE CENTINE SONO CALCOLATI RISPETTO AI LORO ASSI, AL NETTO DELLE PIASTRE.
- LE MISURE ANGOLARI SONO ESPRESSE IN GRADI SESSAGESIMALI.
- EVENTUALI DIFFERENZE TRA LE MISURE TOTALI E LE SOMMATORIE DELLE MISURE PARZIALI SONO DOVUTE AGLI ARROTONDAMENTI AUTOMATICI DI AUTOCAD.

**LEGENDA**

- P.C. PIANO DEI CENTRI
- P.F. PIANO DEL FERRO
- P.S. PIANO DI SCIVIO
- Q.P. PIANO QUOTATO

**CARATTERISTICHE SALDATURE**



**COMMITTENTE**



**DIREZIONE LAVORI**



**APPALTATORE**



**PROGETTAZIONE**



**PROGETTO ESECUTIVO**

**ITINERARIO NAPOLI - BARI**

**RADDOPPIO TRATTA APICE - ORSARA**

**CAMERONE DI BOSTA**

**FASI ESECUTIVE**

**Campo 4 - Centina - carpenteria**

**APPALTATORE**

**DIREZIONE DELLA PROGETTAZIONE**

**PROGETTISTA**

**COMMESSA**

**LOTTO**

**FASE**

**ENTE**

**TIPO DOC.**

**OPERAZIONE/OPERA**

**PROGR.**

**REV.**

**SCALA**

File: IF3A02EZZB8GN0200013A.dwg n. Dib.