

QUANTITA' RELATIVE AD UN CAMPO DI 11 CENTINE

PROFILATO	TIPO	NUM	PESO (Kg)
Travi HE	HE300B	1	97.76
Travi HE	HE300B	1	97.91
Travi HE	HE300B	1	98.20
Travi HE	HE300B	1	99.08
Travi HE	HE300B	2	196.10
Travi HE	HE300B	2	199.54
Travi HE	HE300B	6	599.49
Travi HE	HE300B	4	398.40
Travi HE	HE300B	2	201.02
Travi HE	HE300B	2	201.89
Travi HE	HE300B	22	6440.94
Travi HE	HE300B	1	489.75
Travi HE	HE300B	1	461.20
Travi HE	HE300B	22	10064.35
Travi HE	HE300B	1	462.86
Travi HE	HE300B	1	498.29
Travi HE	HE300B	1	499.01
Travi HE	HE300B	1	498.70
Travi HE	HE300B	2	1041.02
Travi HE	HE300B	1	535.24
Travi HE	HE300B	1	533.84
Travi HE	HE300B	1	536.80
Travi HE	HE300B	2	1137.00
Travi HE	HE300B	1	572.25
Travi HE	HE300B	1	572.30
Travi HE	HE300B	1	572.41
Travi HE	HE300B	2	1218.57
Travi HE	HE300B	1	608.47
Travi HE	HE300B	2	1232.96
Travi HE	HE300B	1	646.27
Travi HE	HE300B	1	646.34
Travi HE	HE300B	1	646.53
Travi HE	HE300B	2	1328.90
Travi HE	HE300B	1	683.28
Travi HE	HE300B	1	683.36
Travi HE	HE300B	2	1424.84
Travi HE	HE300B	1	720.29
Travi HE	HE300B	1	720.38
Travi HE	HE300B	1	720.85
Travi HE	HE300B	1	727.30
Travi HE	HE300B	1	757.40
Travi HE	HE300B	1	757.71
Travi HE	HE300B	1	760.57
Travi HE	HE300B	1	759.56
Travi HE	HE300B	1	794.31
Travi HE	HE300B	1	794.39
Travi HE	HE300B	1	794.77
Travi HE	HE300B	2	1416.72
Travi HE	HE300B	1	831.32
Travi HE	HE300B	1	831.45
Travi HE	HE300B	1	831.83
Travi HE	HE300B	1	856.51
Travi HE	HE300B	1	855.50
Travi HE	HE300B	1	904.48
Travi HE	HE300B	1	903.47
Travi HE	HE300B	1	953.07
Travi HE	HE300B	1	951.41
Travi HE	HE300B	2	2000.48
		121	56752.94

CARPENTERIA CENTINA - TIPO A6  
SCALA 1:25

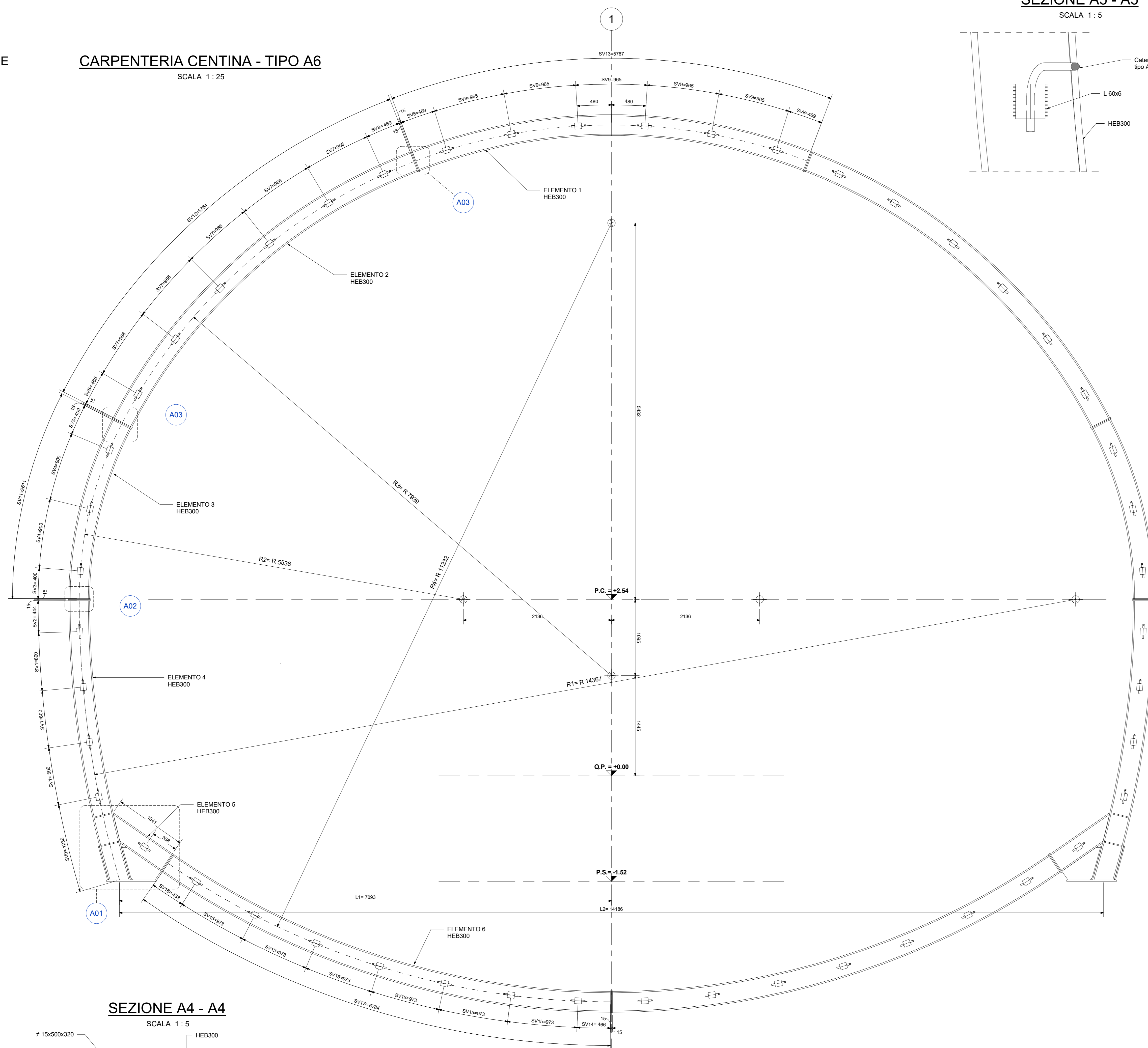

DETTAGLIO A03  
SCALA 1:5

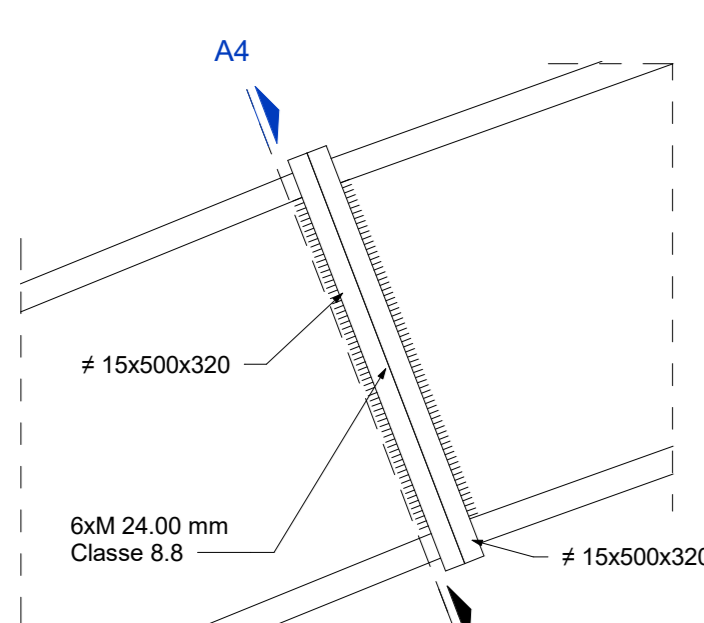

SEZIONE A4 - A4  
SCALA 1:5

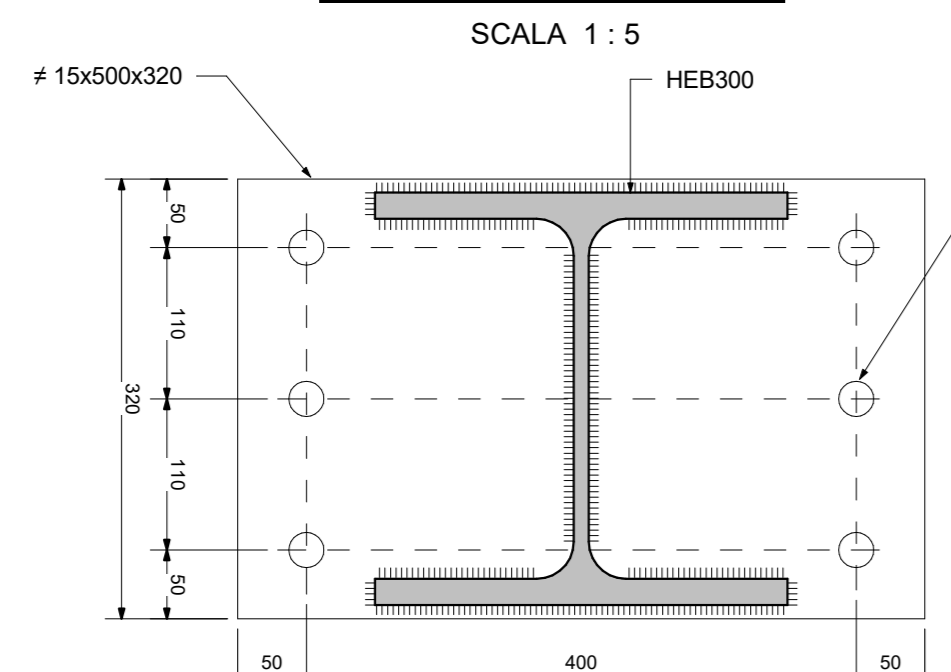

SEZIONE A9 - A9  
SCALA 1:5

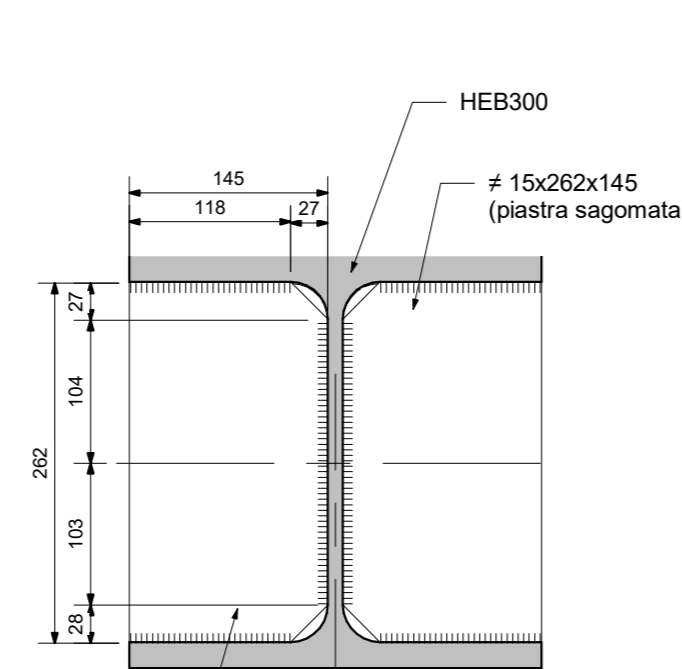

SCHEMA POSIZIONE CENTINE  
SCALA 1:100

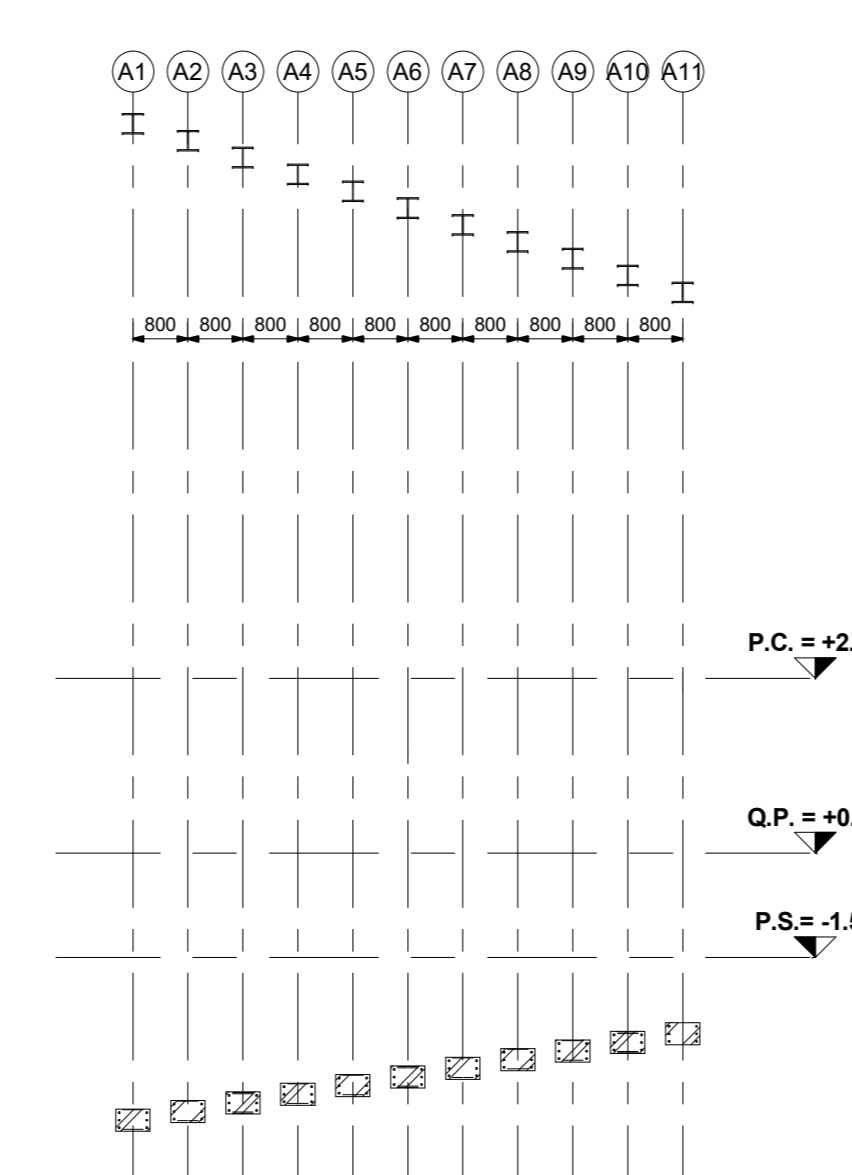

SEZIONE A5 - A5  
SCALA 1:5

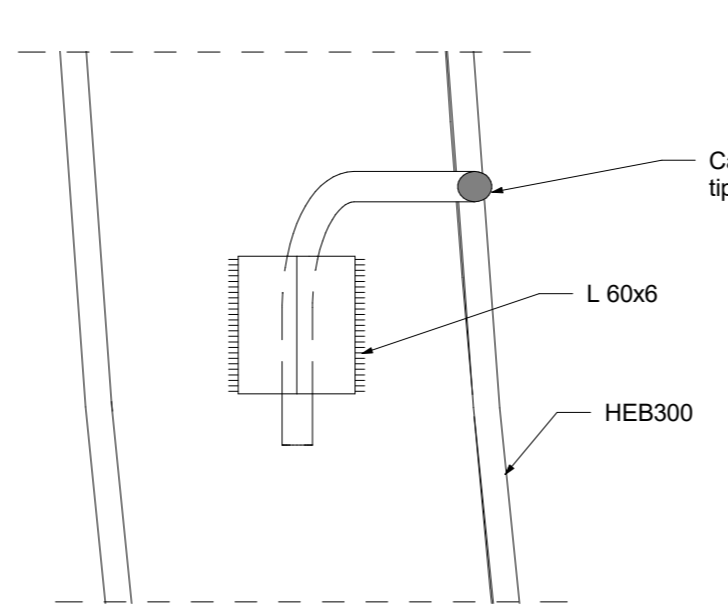

DETTAGLIO A02  
SCALA 1:5

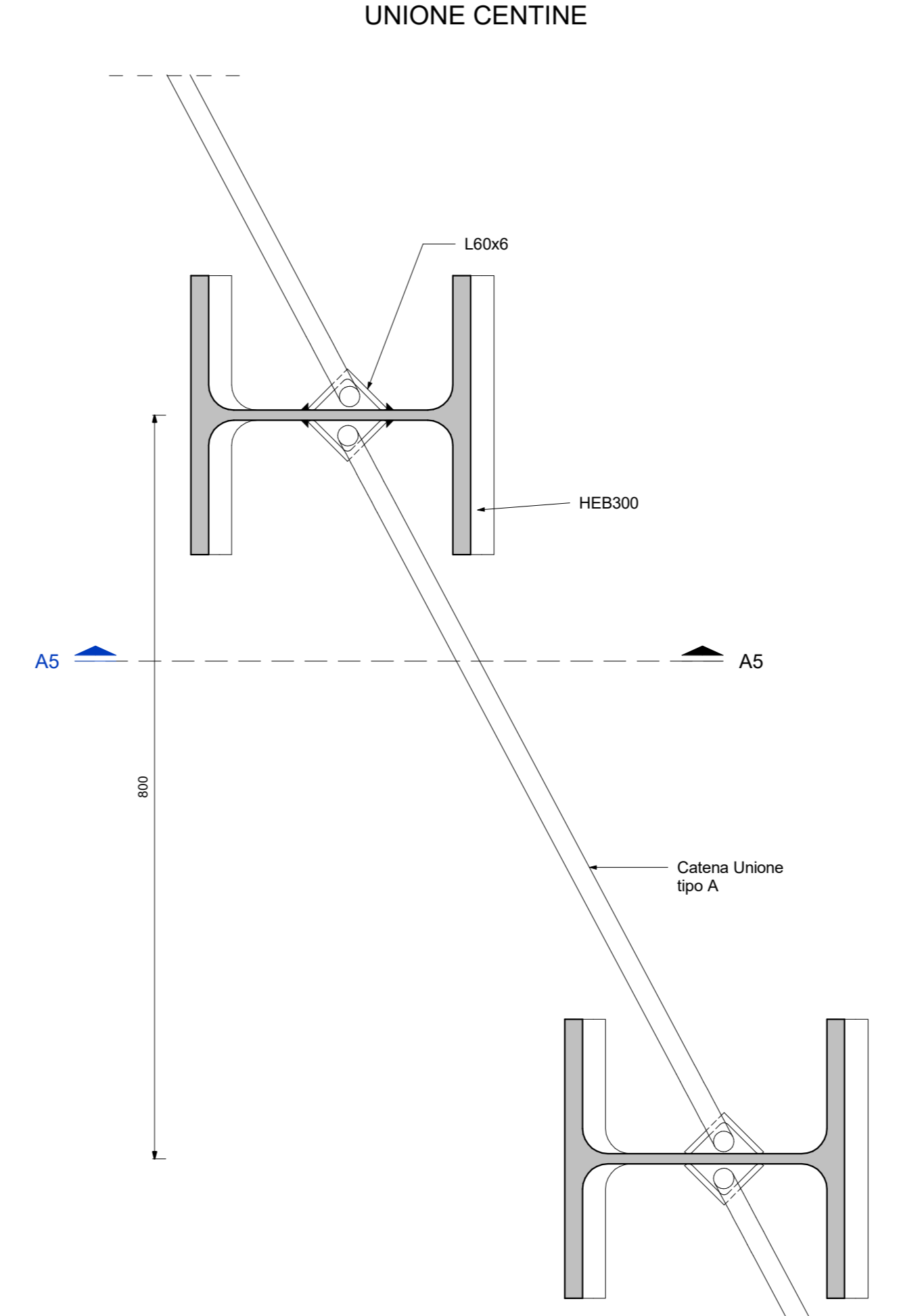

DETTAGLIO CATENA UNIONE  
SCALA 1:5

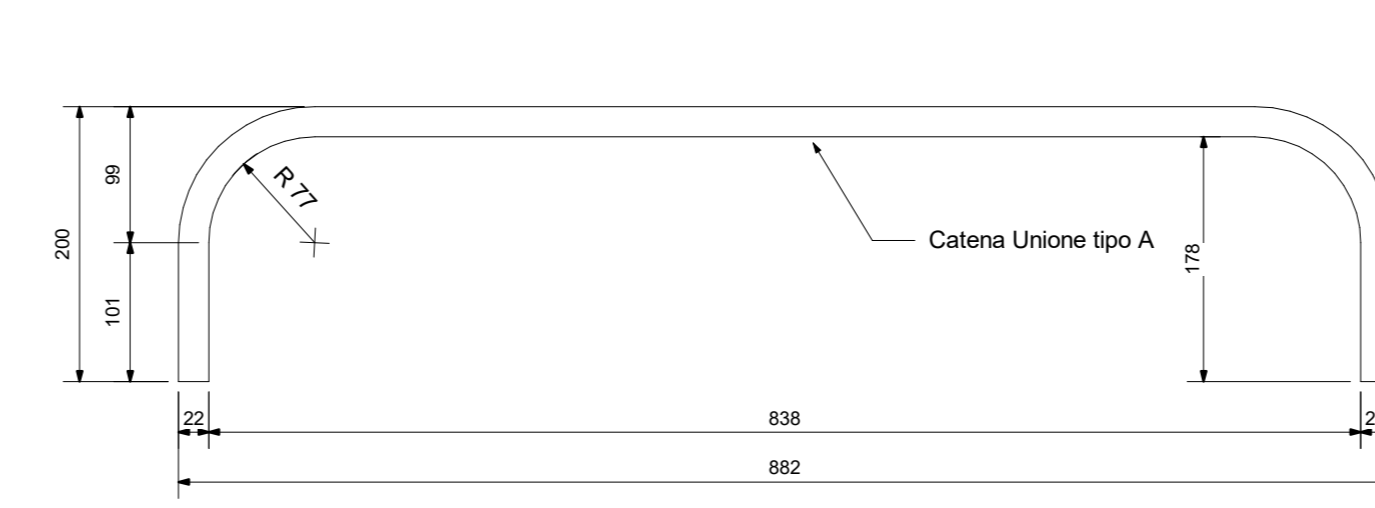

SEZIONE A1 - A1  
SCALA 1:5

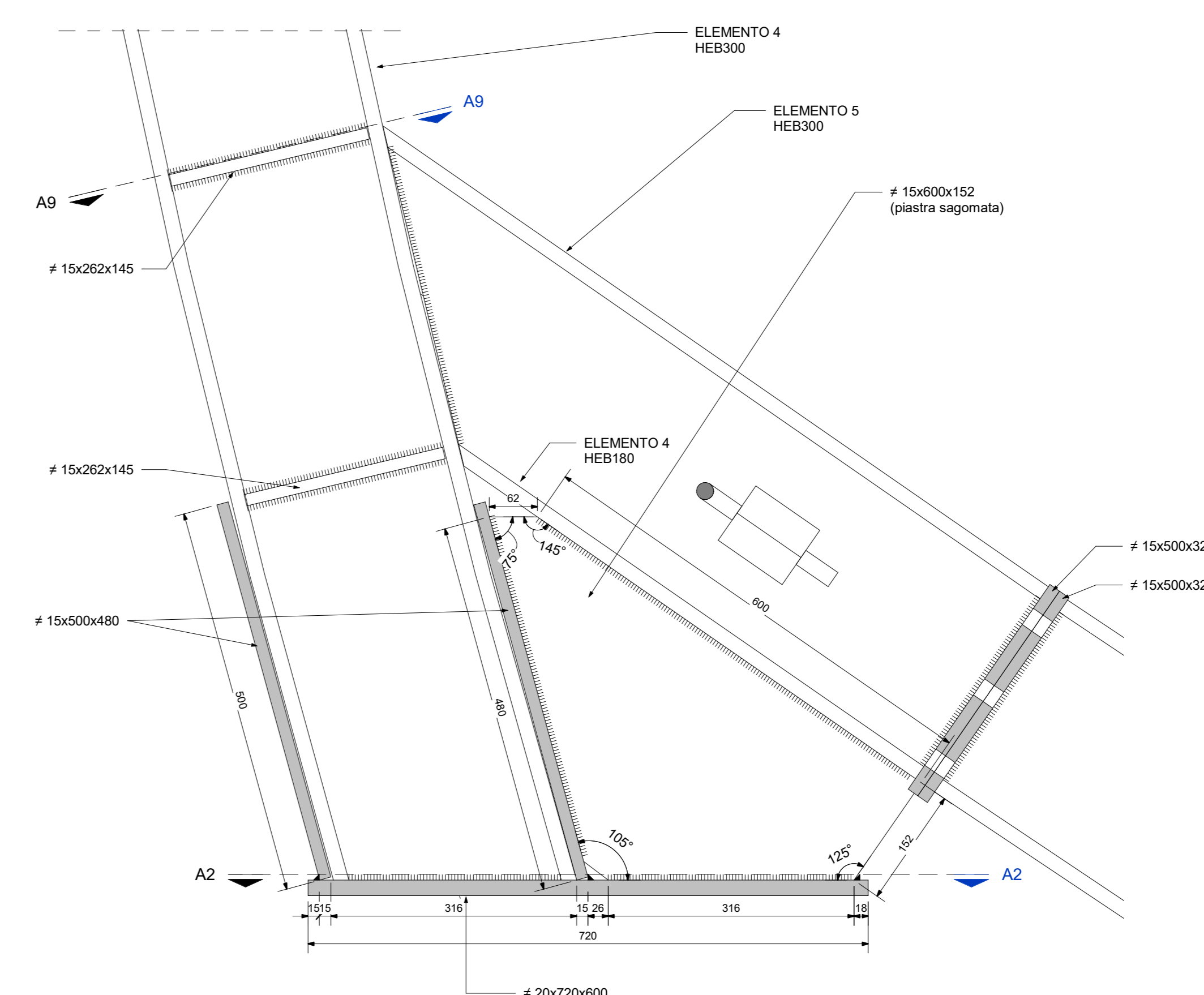

DETTAGLIO A01  
SCALA 1:5

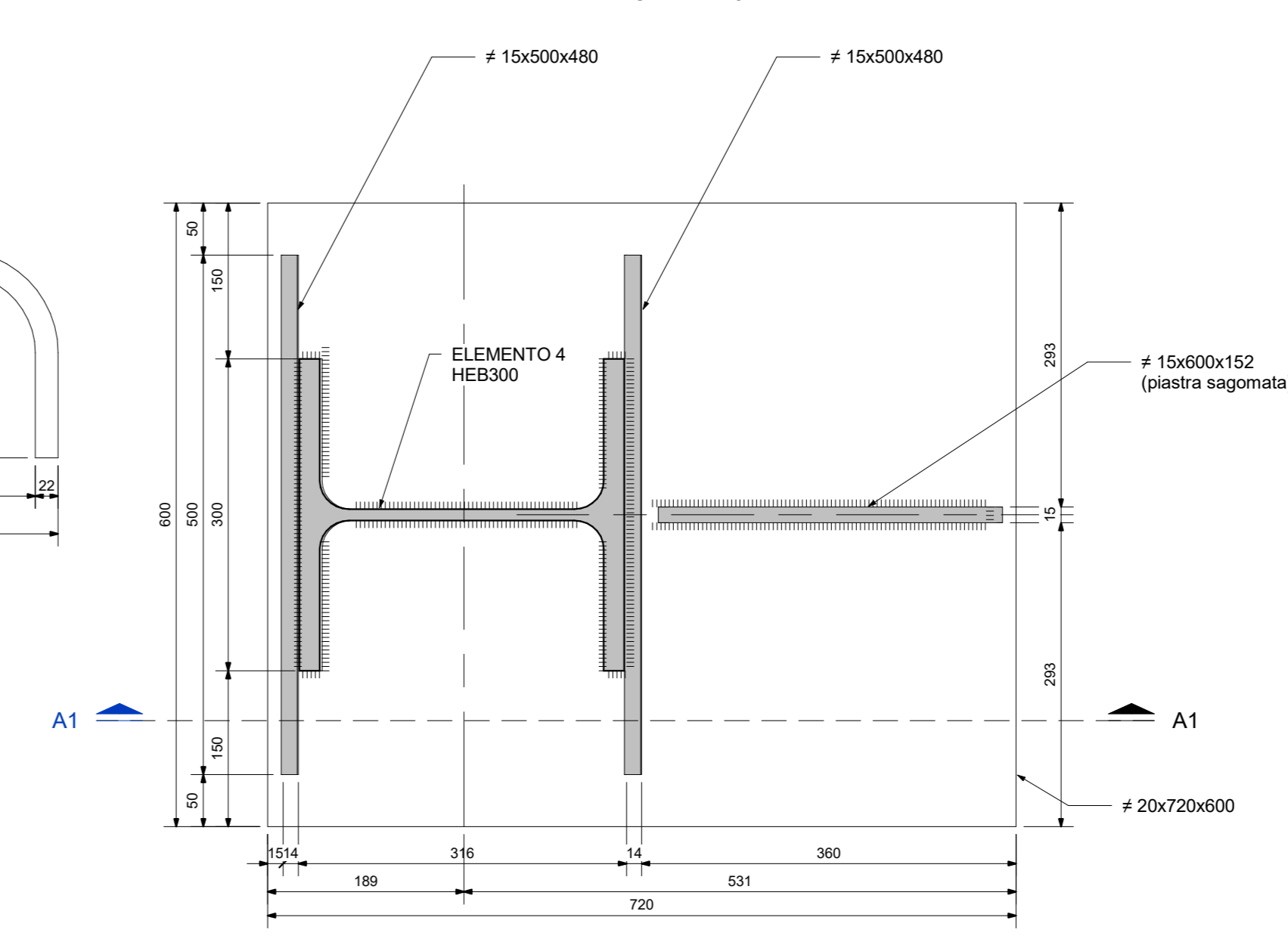

VISTA 3D

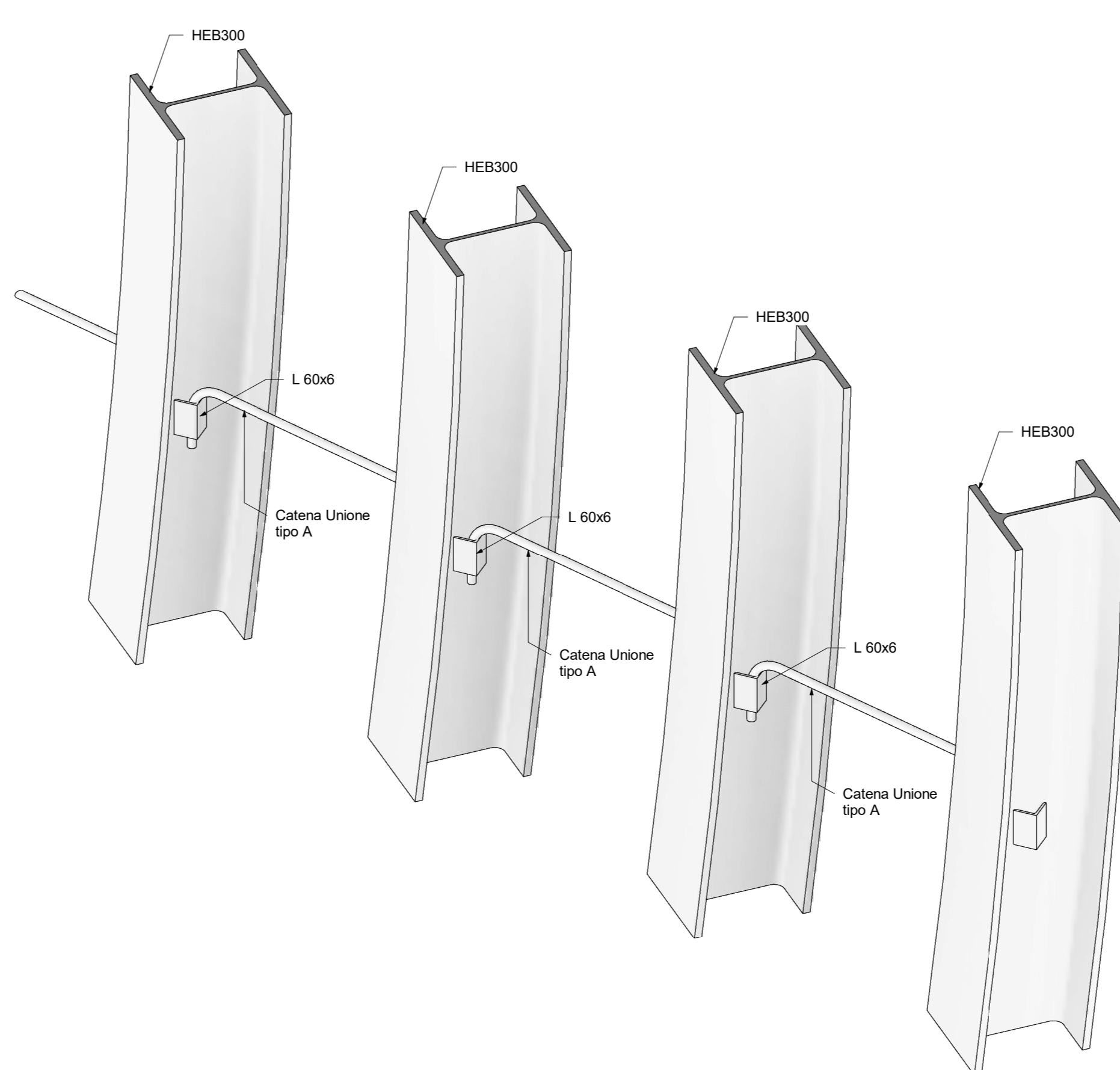

VISTA 3D

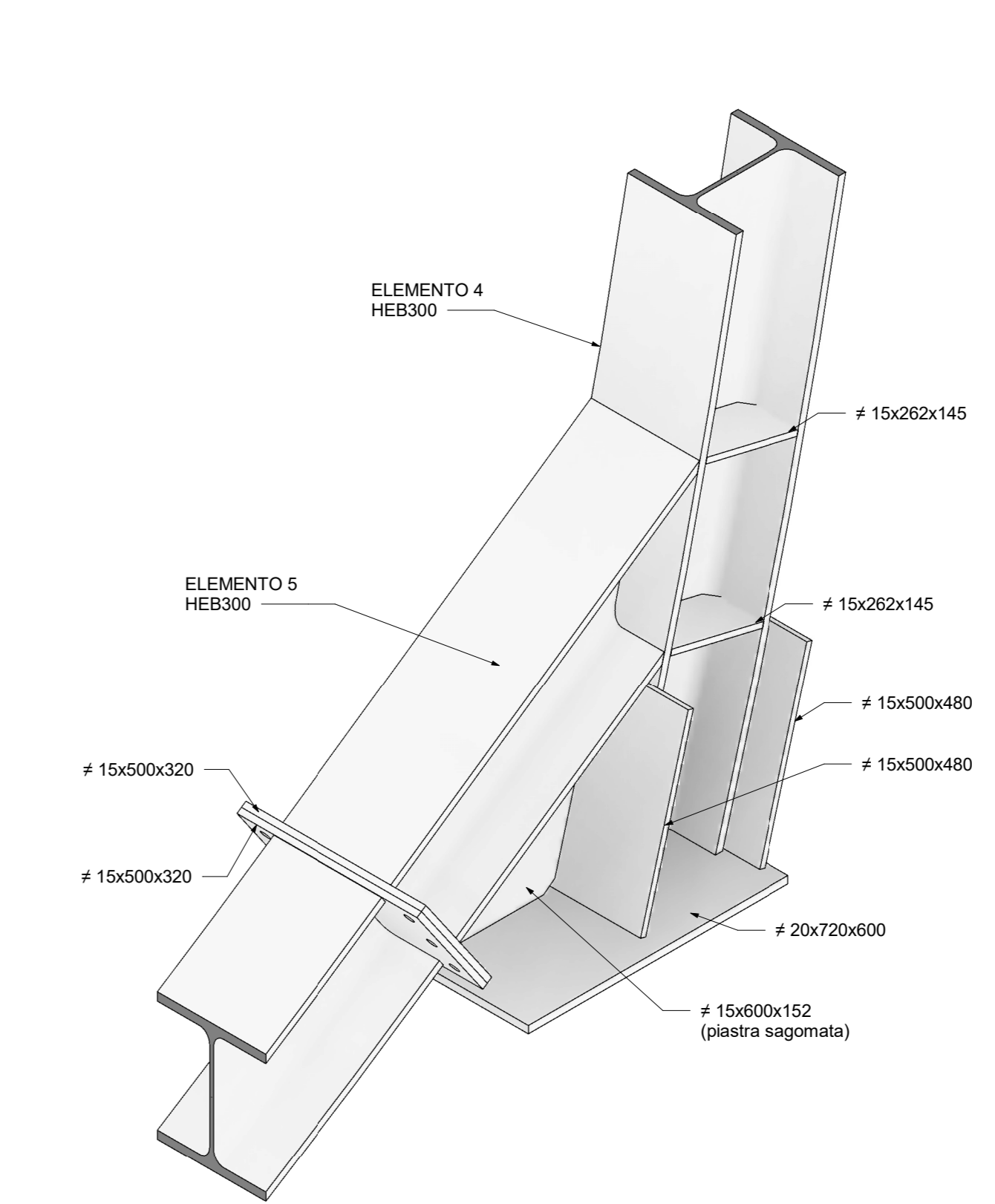

ELENCO ELABORATI DI RIFERIMENTO

IF3A02EZZB8GN0200005	Scavi e consolidamenti - fase di avanzamento - campo 1
IF3A02EZZB8GN0200006	Scavi e consolidamenti - fase di avanzamento - campo 2
IF3A02EZZB8GN0200007	Scavi e consolidamenti - fase di avanzamento - campo 3
IF3A02EZZB8GN0200008	Scavi e consolidamenti - fase di avanzamento - campo 4
IF3A02EZZB8GN0200009	Scavi e consolidamenti - fase di avanzamento - campo 5
IF3A02EZZB8GN0200010	Campo 1 - Centina - carpenteria
IF3A02EZZB8GN0200011	Campo 2 - Centina - carpenteria
IF3A02EZZB8GN0200012	Campo 3 - Centina - carpenteria
IF3A02EZZB8GN0200013	Campo 4 - Centina - carpenteria
IF3A02EZZB8GN0200014	Campo 5 - Centina - carpenteria

NOTE

- LA TABELLA MATERIALI E' RIPORTATA IN UNO SPECIFICO ELABORATO.
- LE MISURE SONO ESPRESSE IN MILLIMETRI.
- LE MISURE E GLI SVILUPPI DELLE CENTINE SONO CALCOLATI RISPETTO AI LORO ASSI, AL NETTO DELLE PIASTRE.
- LE MISURE ANGOLARI SONO ESPRESSE IN GRADI SESSAGESIMALI.
- EVENTUALI DIFFERENZE TRA LE MISURE TOTALI E LE SOMMATORIE DELLE MISURE PARZIALI SONO DOVUTE AGLI ARROTONDAMENTI AUTOMATICI DI AUTOCAD.

LEGENDA

- P.C.	PIANO DEI CENTRI
- P.F.	PIANO DEL FERRO
- P.S.	PIANO DI SCALDO
- Q.P.	PIANO QUOTATO

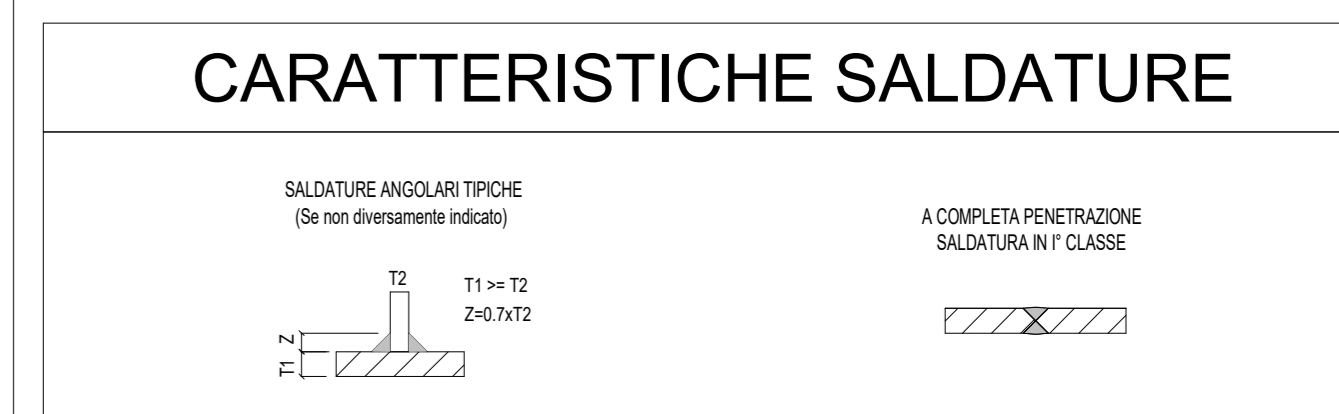

COMMITTENTE: **RFI** (R.F. FERROVIARIA ITALIANA) / **GRUPPO FERROVIE DELLO STATO ITALIANI**

DIREZIONE LAVORI: **webuild Italia** / **ITALFER** (GRUPPO FERROVIE DELLO STATO ITALIANI)

APPALTATORE: **HRPINA - ORSARA AV** / **PIZZAROTTI**

PROGETTAZIONE: **NET** / **OPINI** / **GPF** / **SEI ELETTRICI PER**

PROGETTO ESECUTIVO

ITINERARIO NAPOLI - BARI  
RADDOPPIO TRATTA APICE - ORSARA

GN02 - USCITA/ACCESSO DI EMERGENZA CARRABILE F1  
CAMERONE DI BOSTA  
FASI ESECUTIVE  
Campo 5 - Centina - Carpenteria

APALTATORE	DIREZIONE DELLA PROIEZIONE	PROGETTISTA
Consorzio RFPINA - ORSARA AV	Il Responsabile Progettista ha la veste progettuale specialistica	<b>OPINI</b>
Ing. P. M. Giamberini	Ing. S. Conzatti	Ing. M. Taddei

COMMESSA	LOTTO	FASE	ENTE	TIPO DOC.	OPERAZIONE/PLA	PROGR.	REV.	SCALA
IF3A	02	E	ZZ	BZ	GN020200	014	A	varie

Rev.	Descrizione	Redatto	Verificato	Data	Approvato	Data	Autore/Rev.	Data
A	Catena Unione	Manfredi	Manfredi	14/04/2020	Manfredi	14/04/2020	ing. P. M.	

File: IF3A02EZZB8GN0200014A.dwg n. Emb.