

OT. RIF. 191.00

NUMERO SEZIONI	SEZ. 161	SEZ. 162
DISTANZE PROGRESSIVE	0+013.83	0+032.16
DISTANZE PARZIALI	19.33	
QUOTE TERRENI	-EUD. 84	-EUD. 75
ETOMETRICHE		

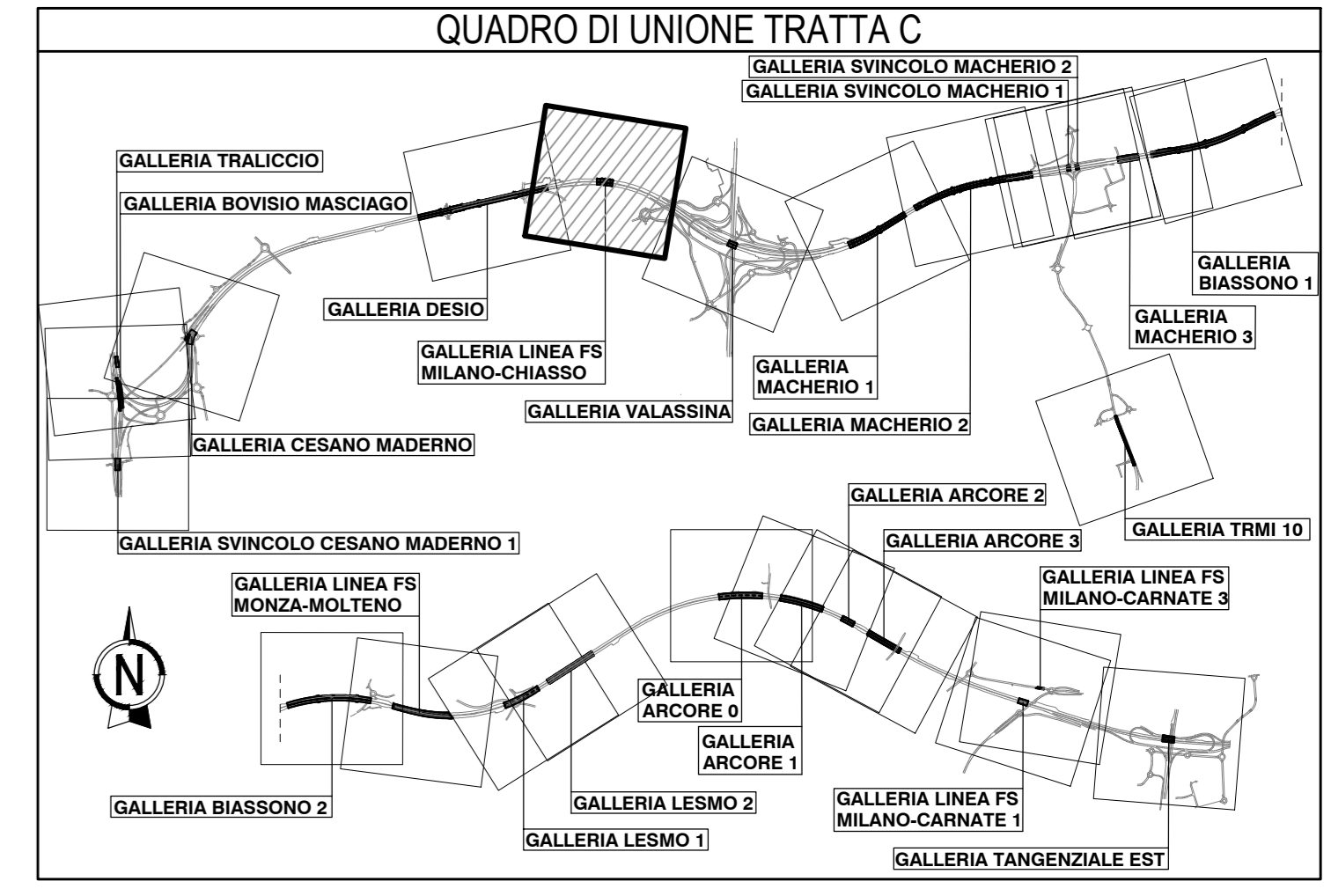
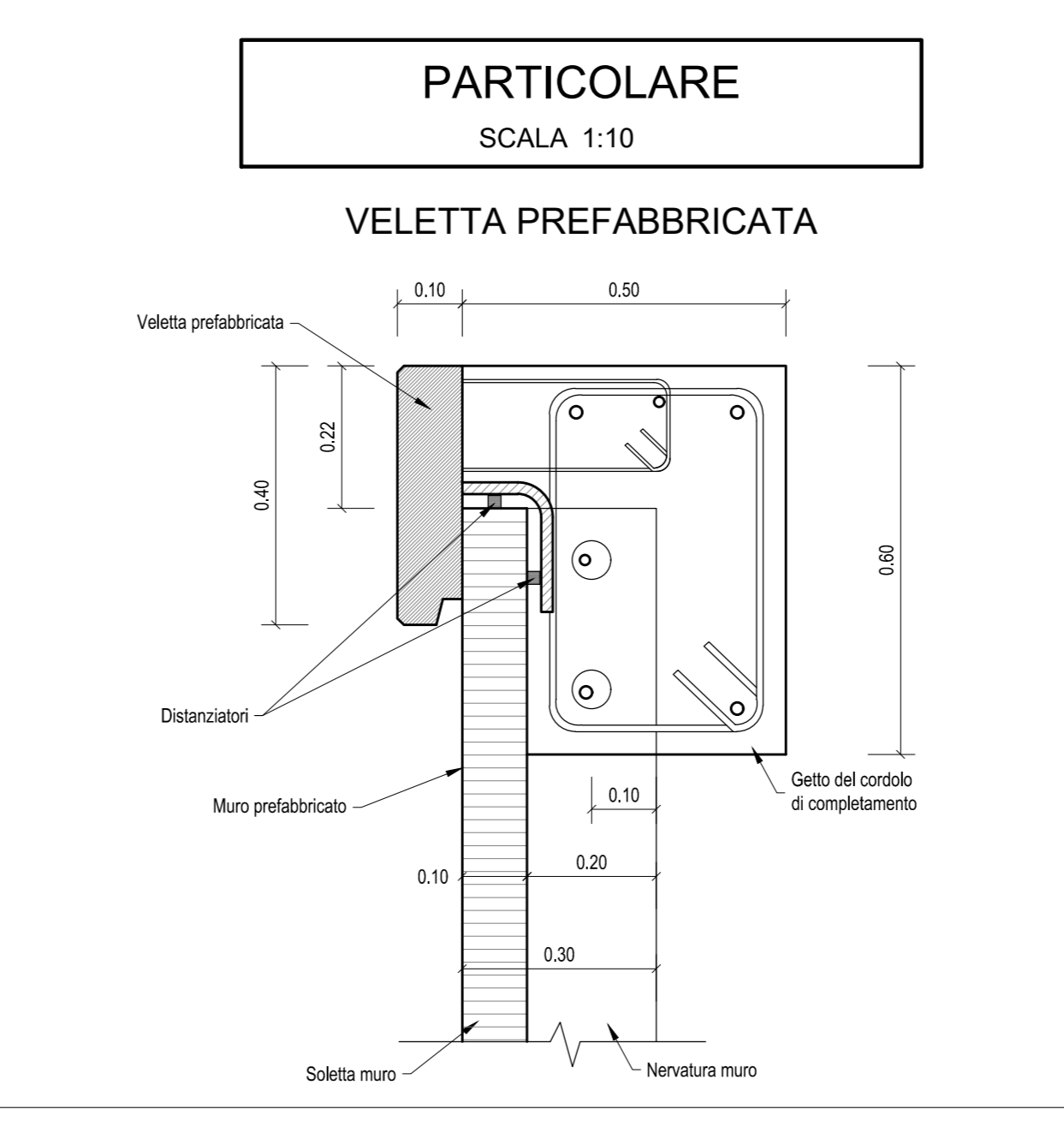
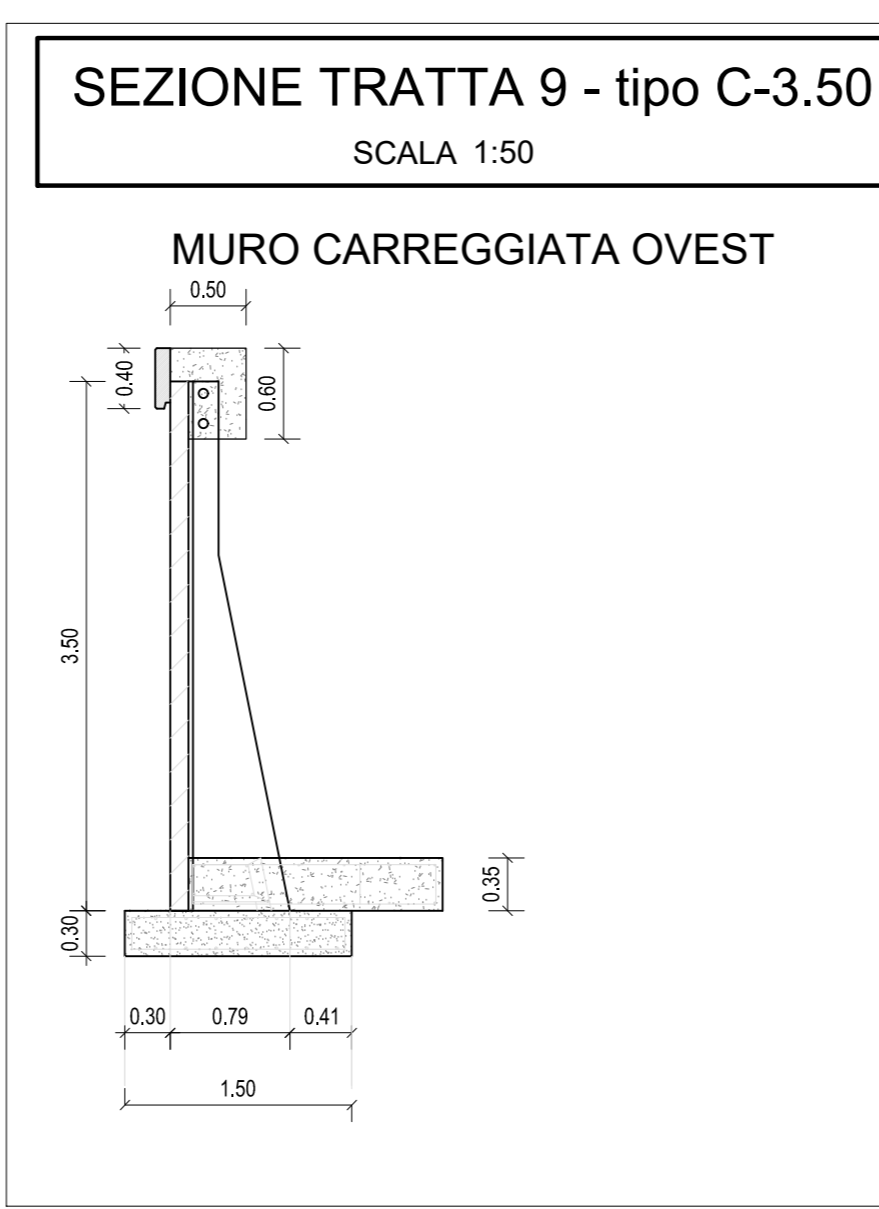
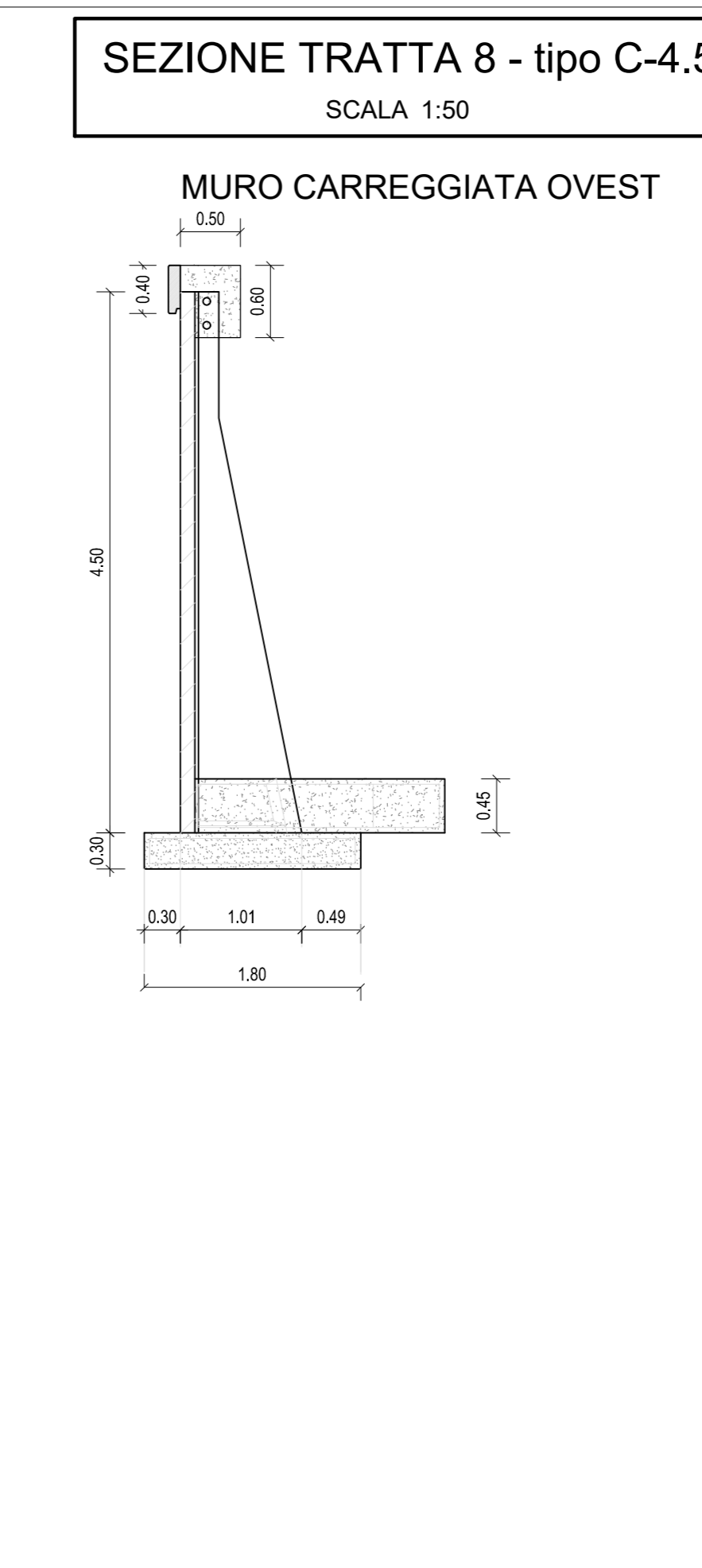
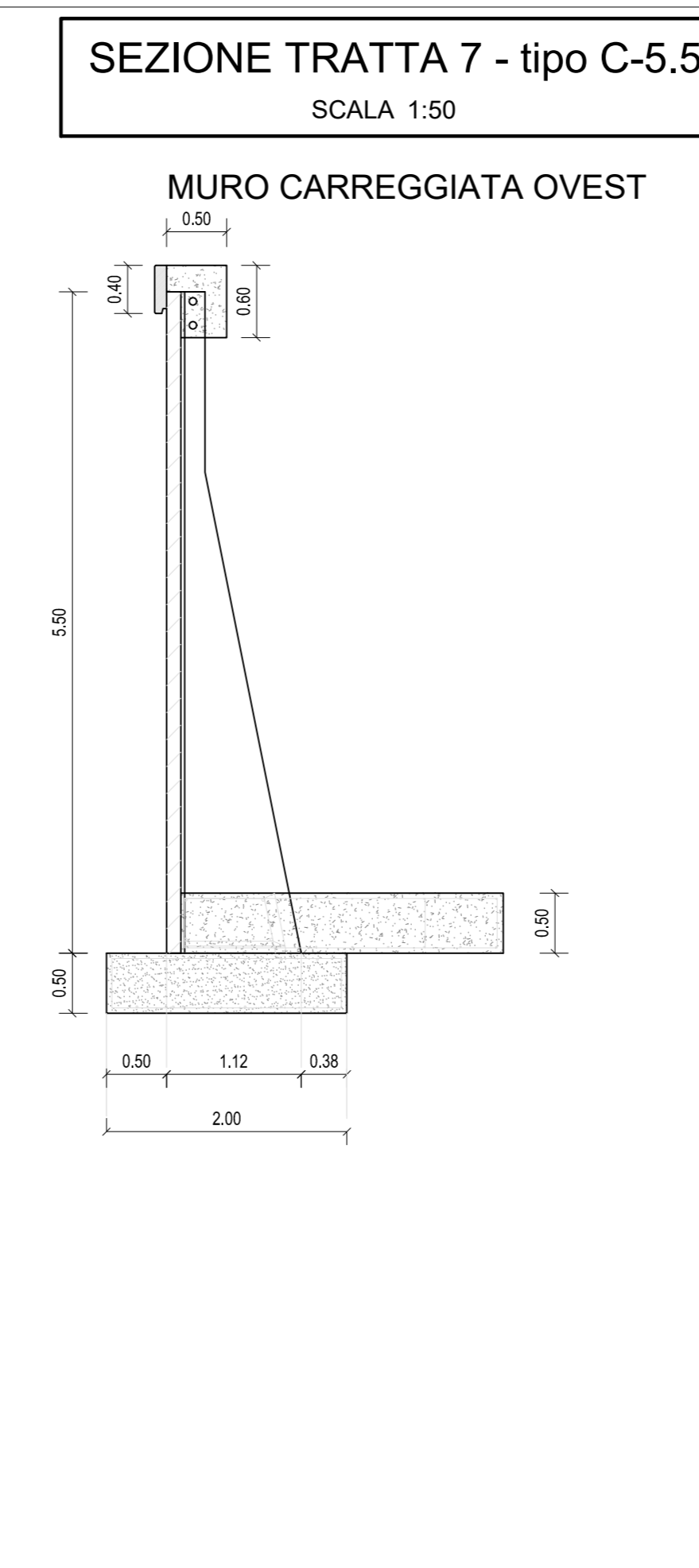
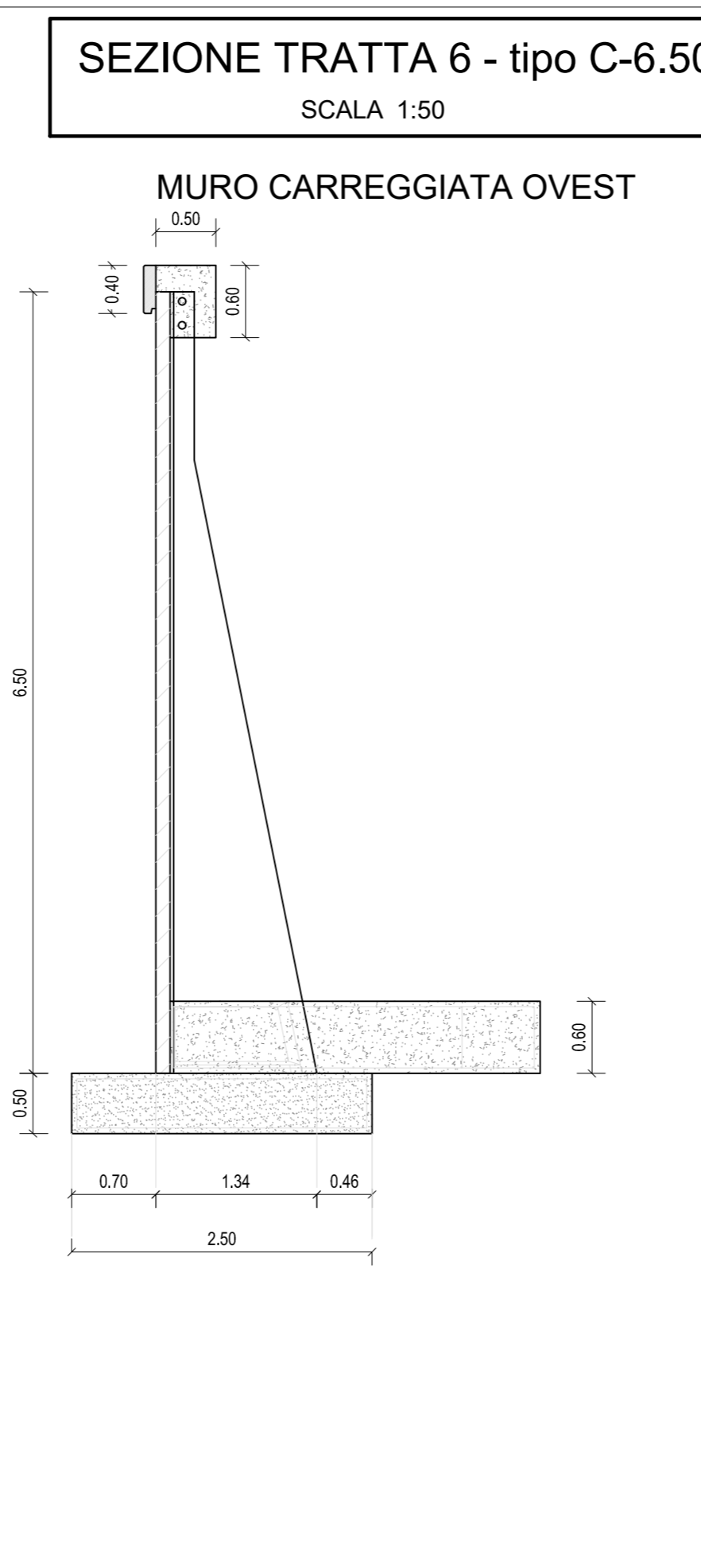
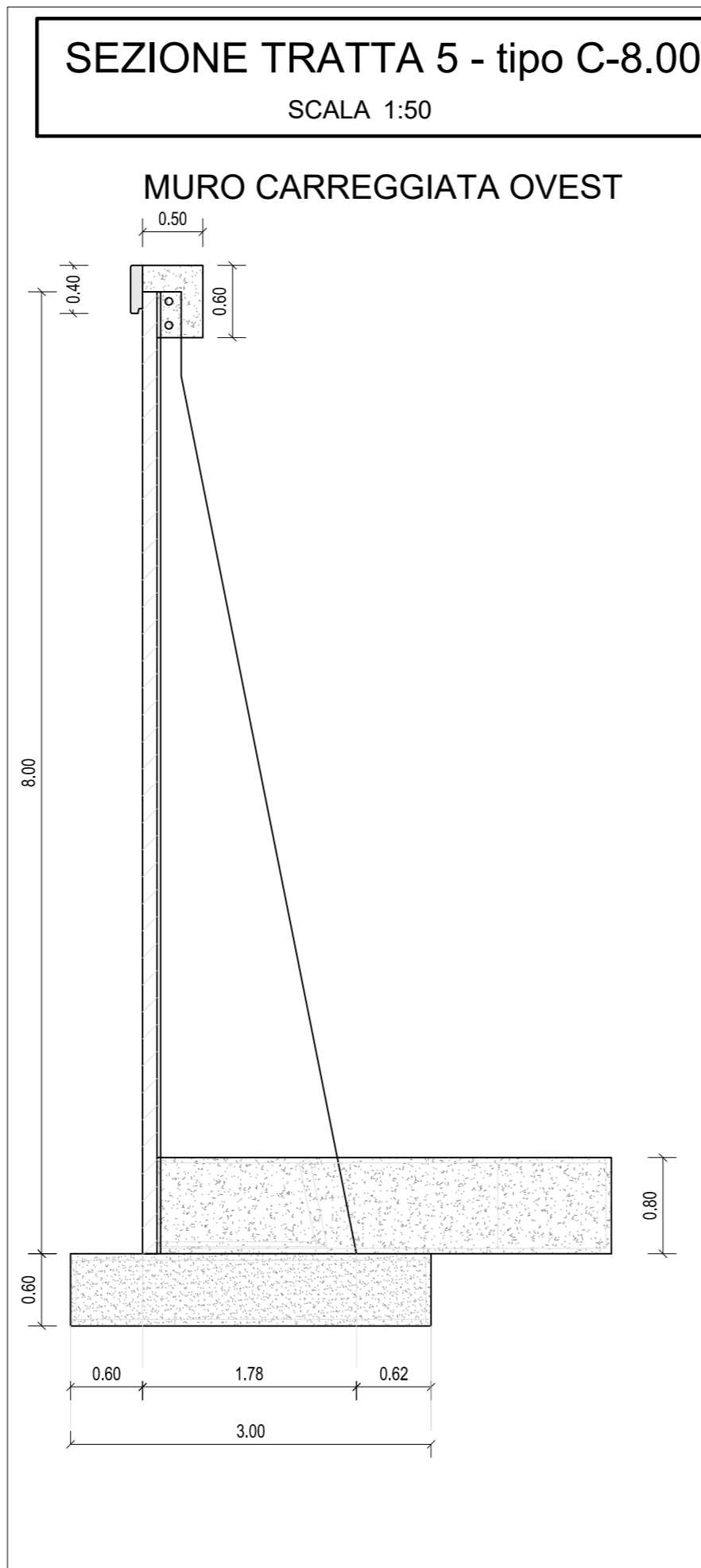
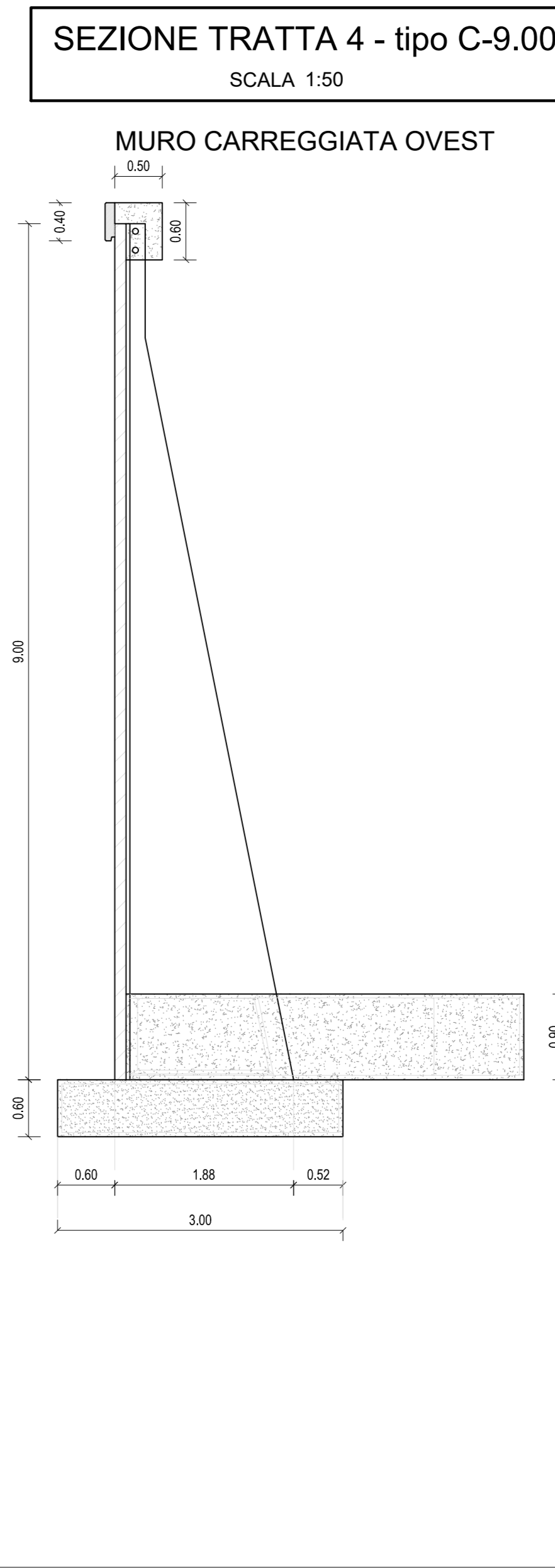
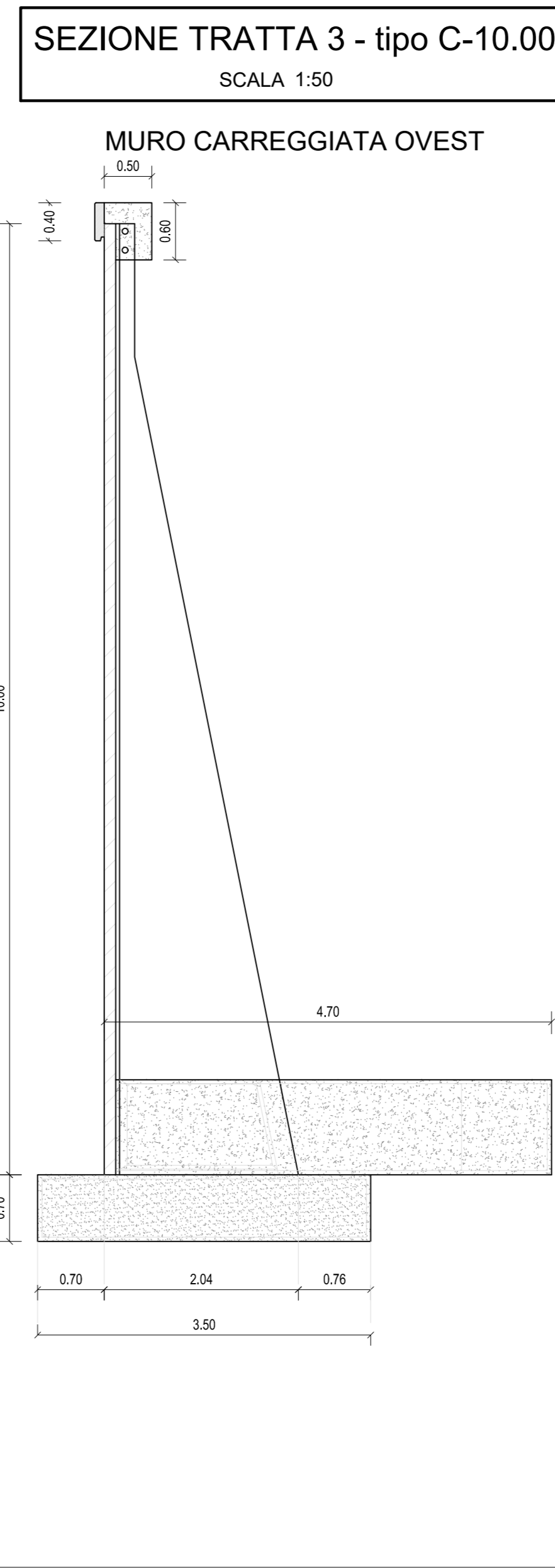
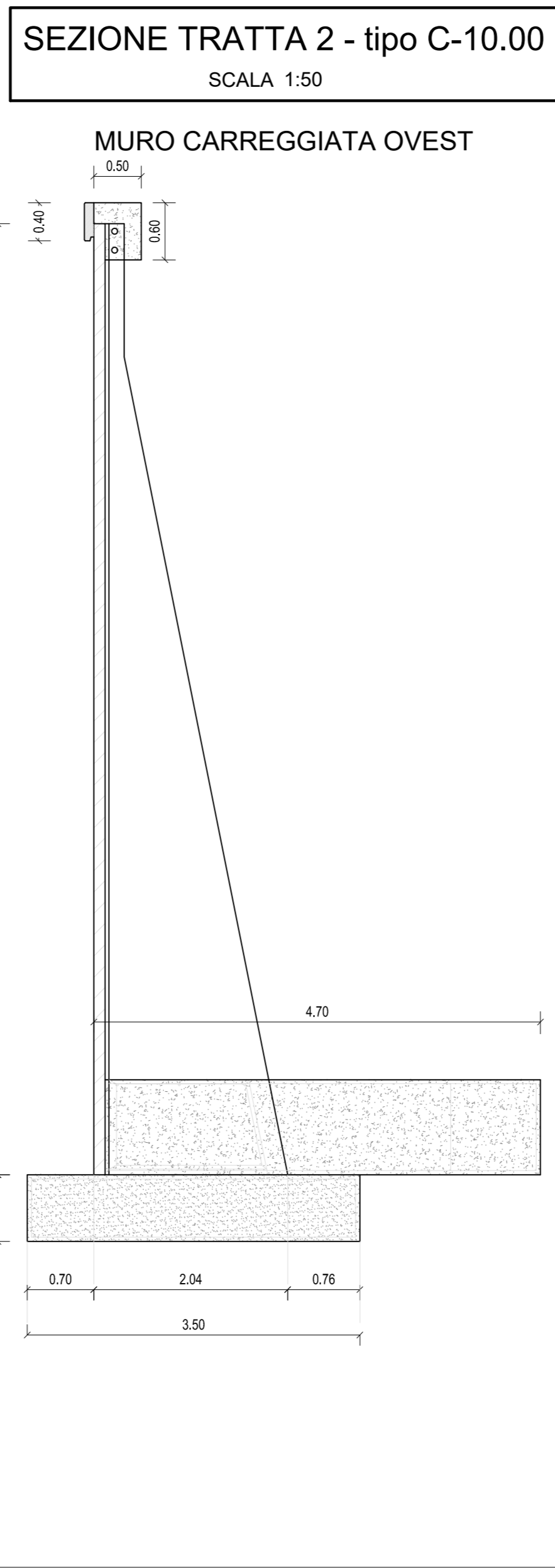
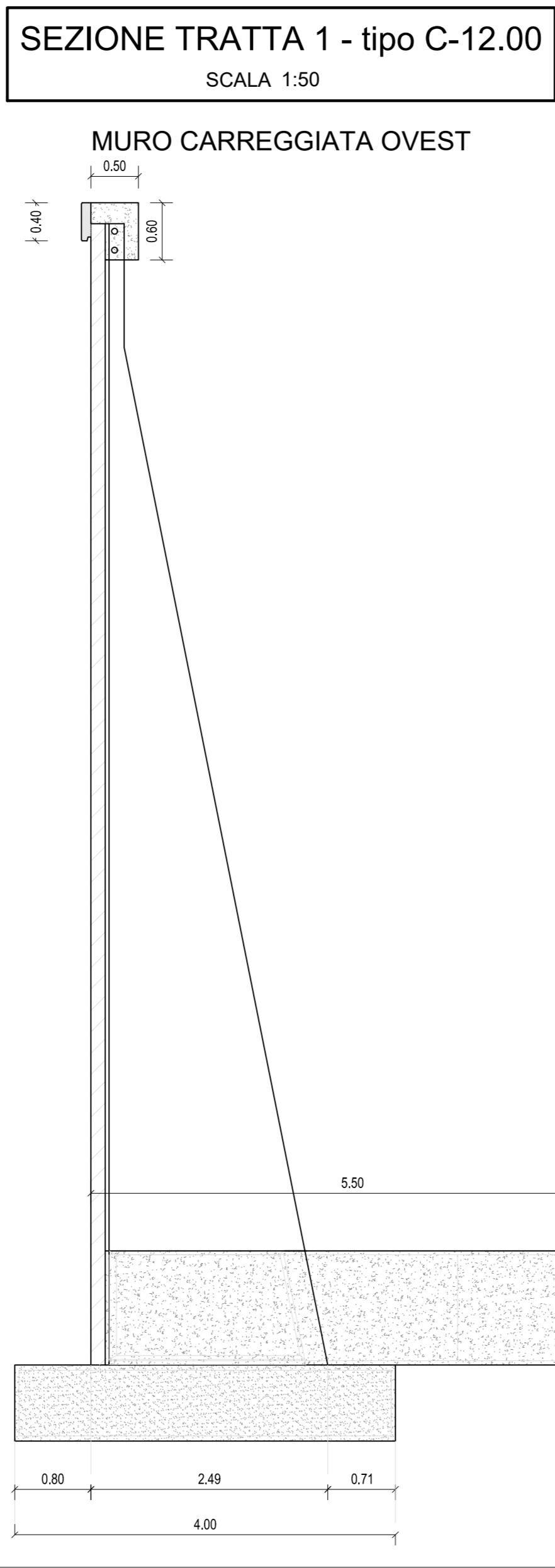
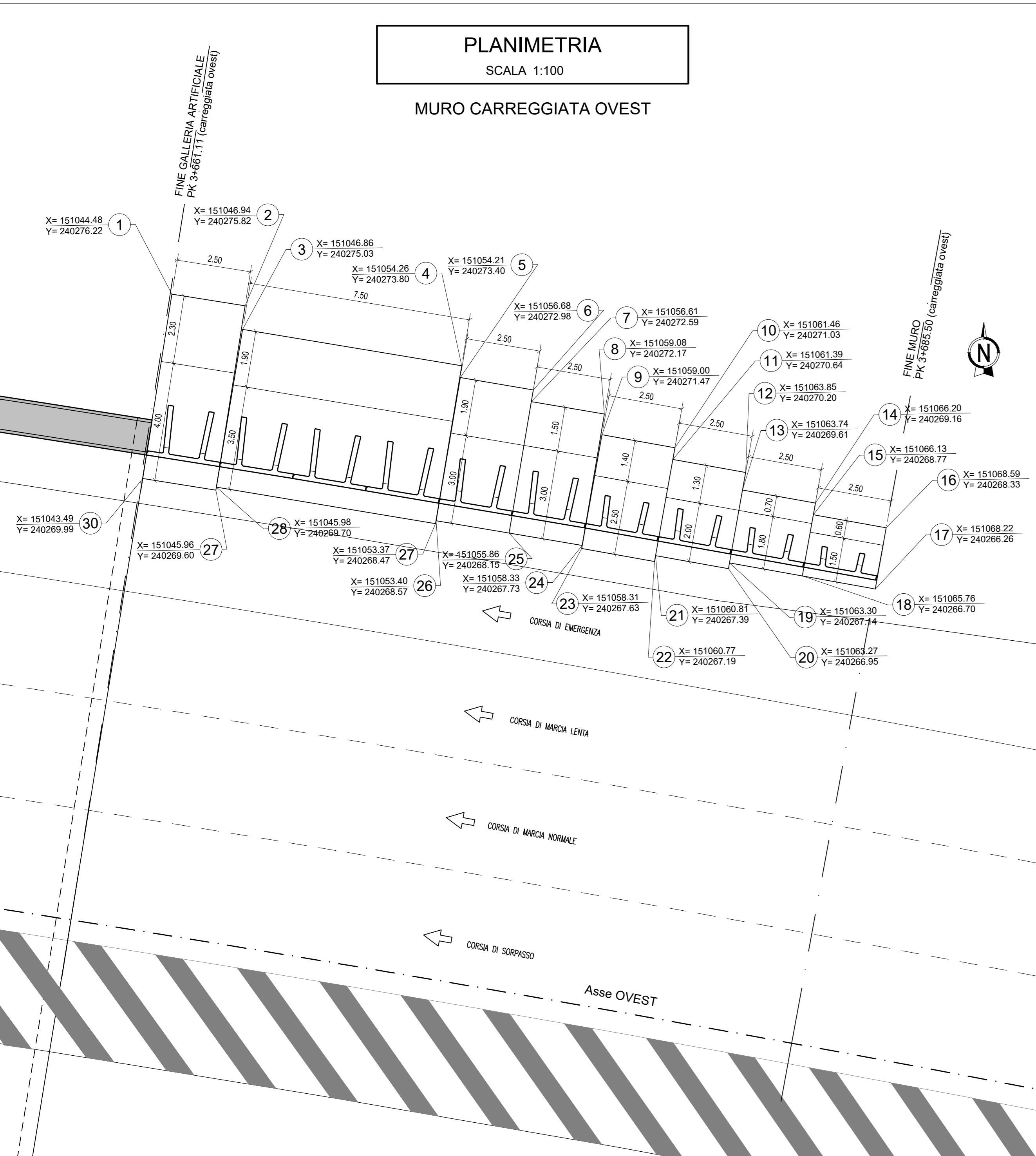

NOTE

- PER QUANTO ATTIENE ALLE ARMATURE DEI PANNELLI DEI MURI SI RIMANDA AGLI ELABORATI:
 ESRGEA03GE00000T027A
 ESRGEA03GE00000T028A
 ESRGEA03GE00000T029A
 ESRGEA03GE00000T030A
 ESRGEA03GE00000T031A



COLLEGAMENTO AUTOSTRADALE DALMINE-COMO-VARESE-VALICO DEL GAGGIOLO E OPERE AD ESSO CONNESSE

PROGETTO ESECUTIVO TRATTA C

OPERE D'ARTE MAGGIORI
 GALLERIE ARTIFICIALI
 GALLERIA LINEA FS MILANO-CHIASSO
 MURI PREFABBRICATI IN C.A. - CARPENTERIA - PIANTE, PROSPETTO E SEZIONI

IDENTIFICAZIONE ELABORATO		CONTRAENTE GENERALE	
PROGETTO	TRATTA C	PEDELOMBARDA NUOVA S.p.A.	
DATA	REVISIONE	ELABORAZIONE PROGETTUALE	
2020/2021	01	PROGETTO	RESPONSABILE PROGETTAZIONE
		REVISIONE	PRESTAZIONE SPECIALE
			ING. Carlo Lotti
DATA	SCALA	PRODOTTO	PRODOTTO
Luglio 2023	1:500	PRODOTTO	PRODOTTO

CONCORSO EDILIZIO

CONCORSO EDILIZIO

CONCORSO EDILIZIO