

1 WBS CBA12 - Callout 01
1 : 200

Abaco Coordinate di Tracciamento - Opere

P.01	E	N
M.169	150637.521085	240270.845846
M.170	150638.149672	240267.912438
M.171	150638.776522	240264.978659
M.172	150639.404295	240262.045078
M.173	150640.033843	240259.111877
M.174	150640.669433	240256.179979
M.175	150641.508110	240255.916305
M.176	150644.443025	240256.537816
M.177	150647.372170	240257.185973
M.178	150650.308564	240257.800459
M.179	150653.244957	240258.414944
M.180	150656.182387	240259.024457
M.181	150659.121184	240259.627342
M.182	150662.060999	240260.225249
M.183	150664.798872	240260.797695
M.184	150667.752303	240261.366675
M.185	150670.693175	240261.953372

Abaco Coordinate di Tracciamento - Opere

P.01	E	N
M.186	150673.639189	240262.543664
M.187	150676.580329	240263.110955
M.188	150679.555631	240263.673177
M.189	150682.498758	240264.226503
M.190	150685.447200	240264.780297
M.191	150688.397806	240265.322443
M.192	150691.348725	240265.862887
M.193	150694.301227	240266.394610
M.194	150697.253867	240266.925570
M.195	150700.209010	240267.442417
M.196	150703.163797	240267.961294
M.197	150706.120627	240268.468402
M.198	150708.819712	240268.926809
M.199	150711.782569	240269.396076
M.200	150714.743124	240269.879657
M.201	150717.703678	240270.363237
M.202	150720.672982	240271.172717
M.203	150723.435142	240272.205363

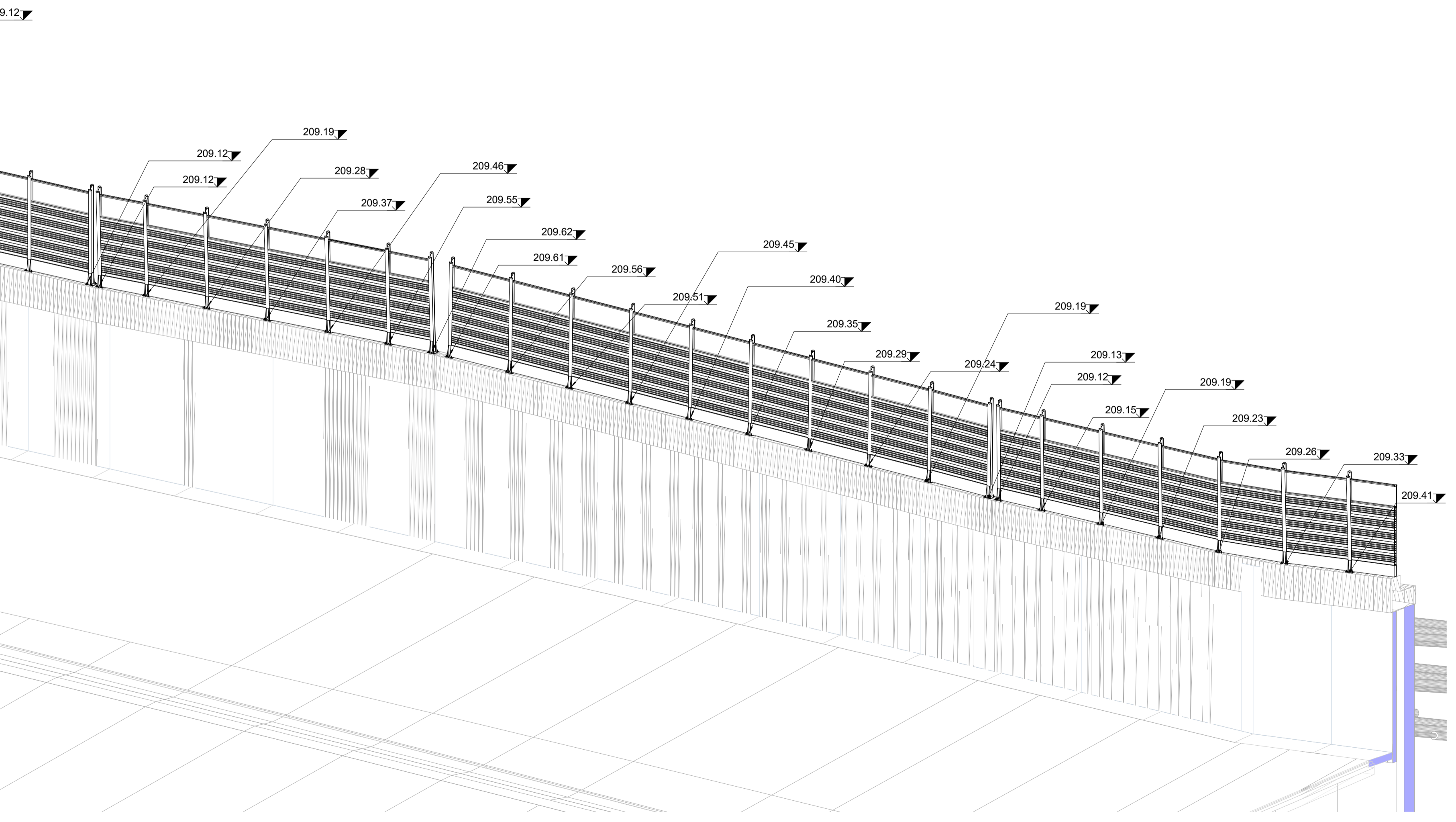
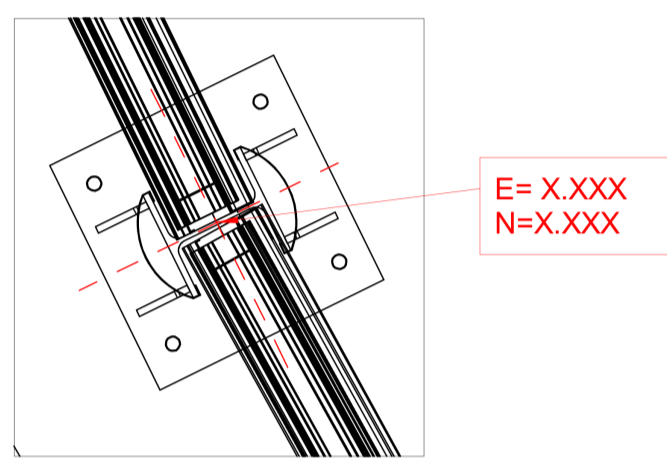

4 Assonometria pt.1

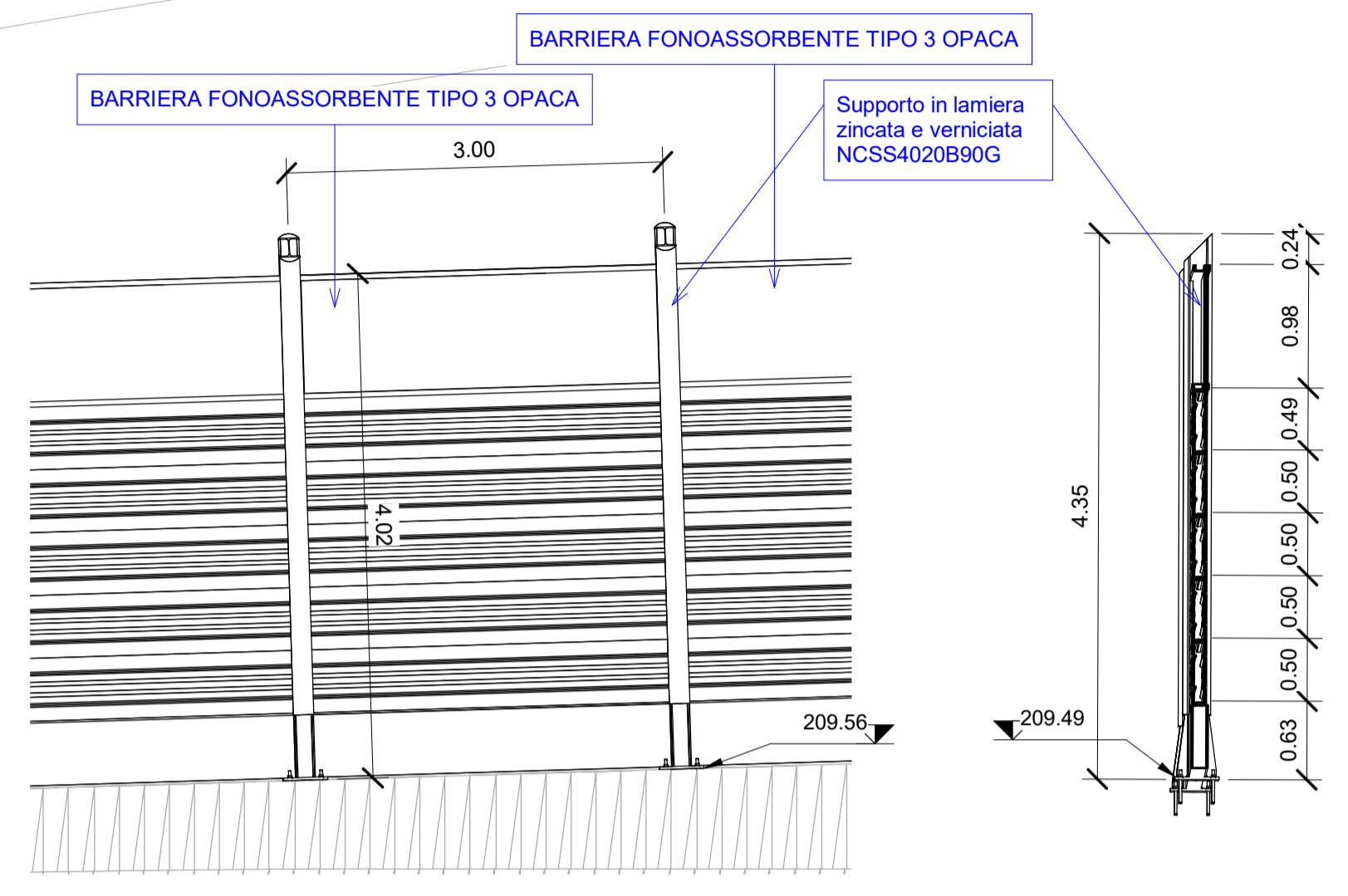

2 Sezione tipologica
1 : 50

3 Sezione tipologica
1 : 50

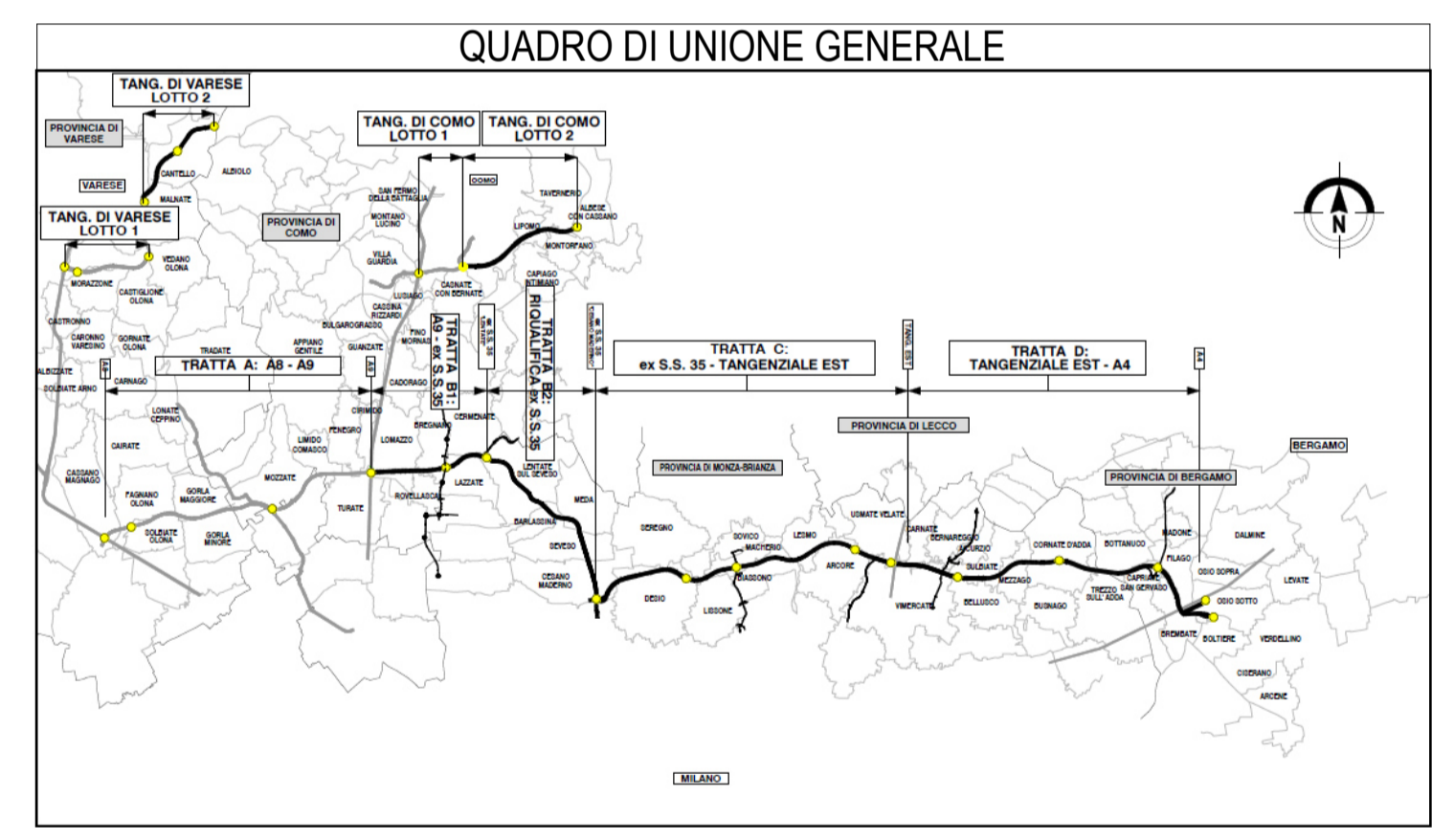
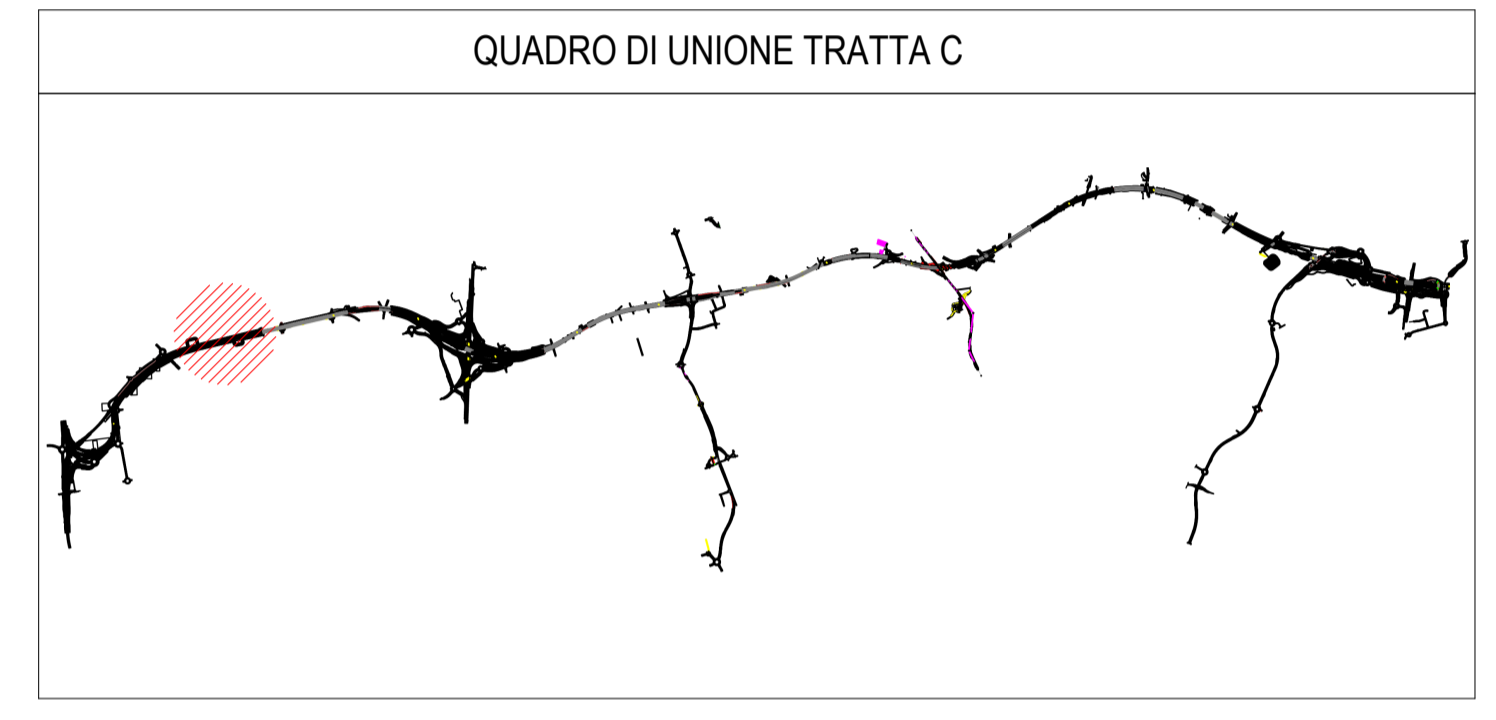

COLLEGAMENTO AUTOSTRADALE
DALMINE-COMO-VARESE-VALICO DEL GAGGIOLO E OPERE AD ESSO CONNESSE
CODICE C.U.P. F118080027001
PROGETTO ESECUTIVO
TRATTA C
 WBS C.BA.12 pt1

IDENTIFICAZIONE ELABORATO				CONTRAENTE GENERALE			
FASE PROGETTUALE	WBS	TRATTA	OPERA	PEDELOMBARDA NUOVA S.c.p.A. DATA: 15/09/2023 REVISIONE: A00 ELABORAZIONE PROGETTUALE: PROGETTISTI: Ing. Alberto Rinaldi, Ing. Erre Via A. S.r.l. RESPONSABILE INTEGRAZIONE SPECIALISTICHE: Ing. Carlo Listori			
AMBITO	AMBE CC	CATEGORIA	OPERA				
PARTE DI OPERA	AS	TIPO ELABORATO	PROGRESSIVA	REVISIONE ESTERNA	CONCESSIONARIO: Autorispettore Pedemontana Lombarda CONCESSIONARIO: Autorispettore Pedemontana Lombarda		
CONCEDENTE	CONCESSIONARI AUTOSTRADALI LOMBARDE	PROGETTISTA: PROGER, ROCK, S&S, S&S, S&S		APPROVATO: Ing. Andrea Molteni, Ing. Enrico Messori			

This document may not be copied, reproduced or published in part or entirely without the written permission of Autorispettore Pedemontana Lombarda S.p.A. Unauthorized use will be persecuted by law.