

Abaco Coordinate di Tracciamento - Opere		
P.01	E	N
M.44	151937.687030	239098.530788
M.45	151937.794001	239101.528880
M.46	151937.900972	239104.526972
M.47	151938.007942	239107.525064
M.48	151938.114913	239110.523157
M.49	151938.221884	239113.521249
M.50	151938.328854	239116.519341
M.51	151938.435825	239119.517433
M.52	151938.542796	239122.515526
M.53	151938.649766	239125.513618
M.54	151938.756737	239128.511710
M.55	151938.863707	239131.509803
M.56	151938.970678	239134.507895
M.57	151939.077649	239137.505987
M.58	151939.184619	239140.504079
M.59	151939.291590	239143.502172
M.60	151939.398561	239146.500264
M.61	151939.505531	239149.498356
M.62	151939.612502	239152.496448
M.63	151939.719473	239155.494541
M.64	151939.826443	239158.492633
M.65	151939.933414	239161.490725
M.66	151940.040385	239164.488818
M.67	151935.119735	239026.576573

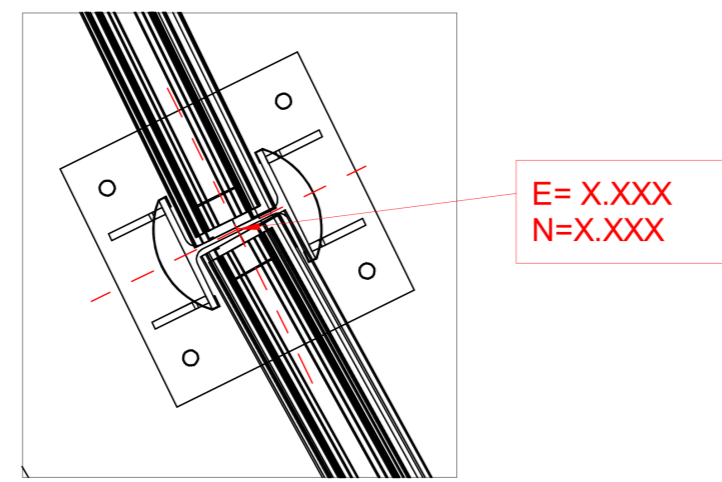

2 Sezione tipologica
1 : 50

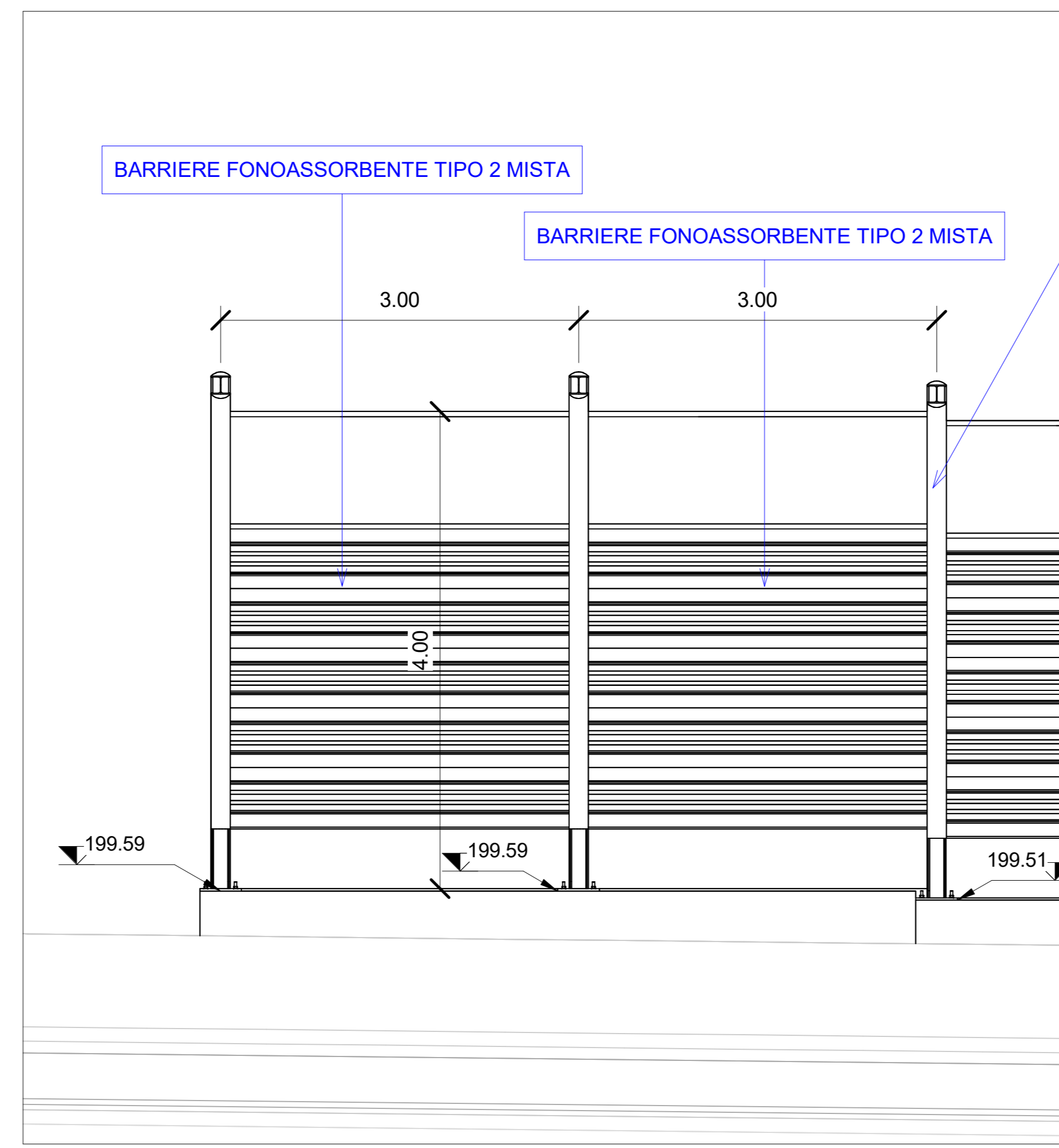

3 Sezione tipologica
1 : 50

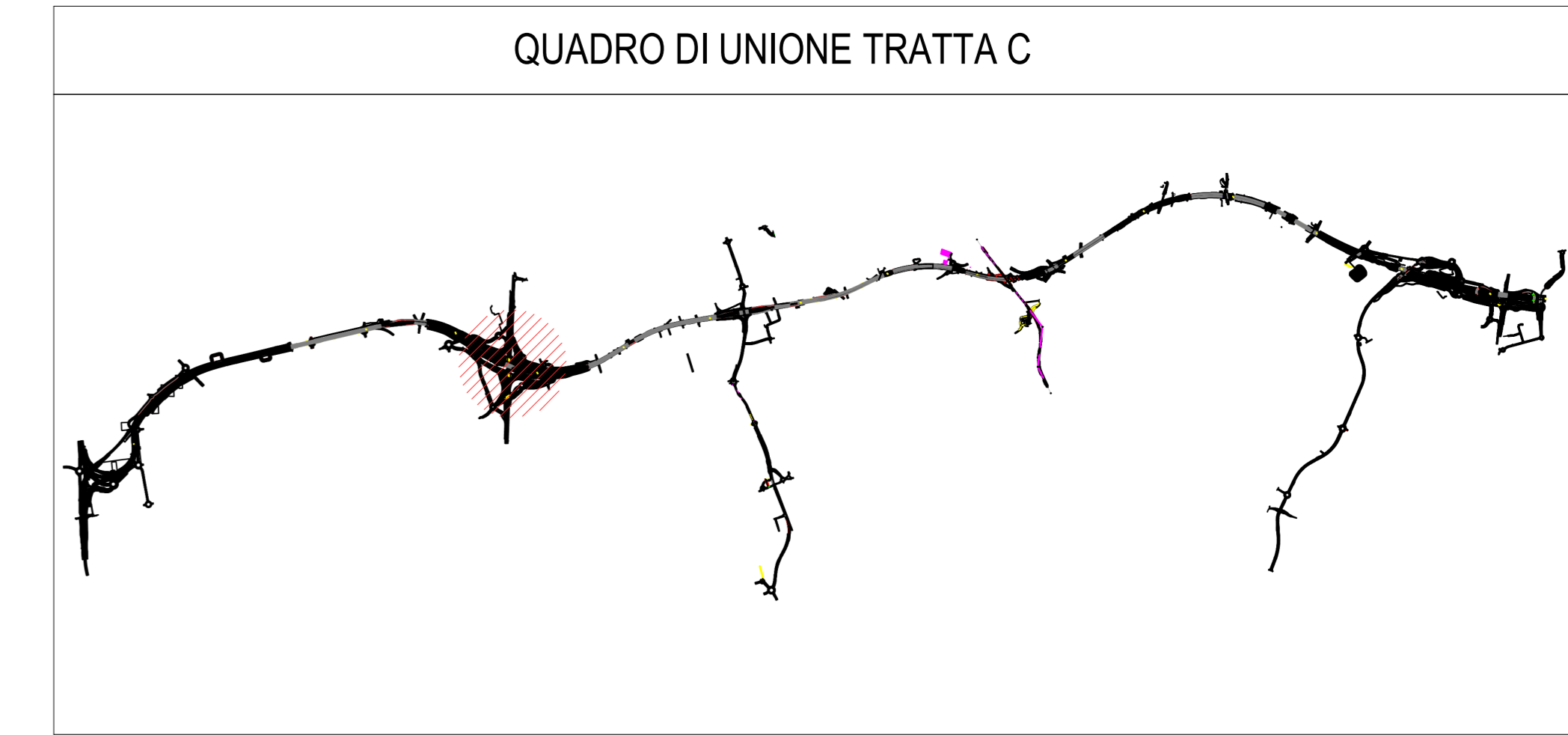
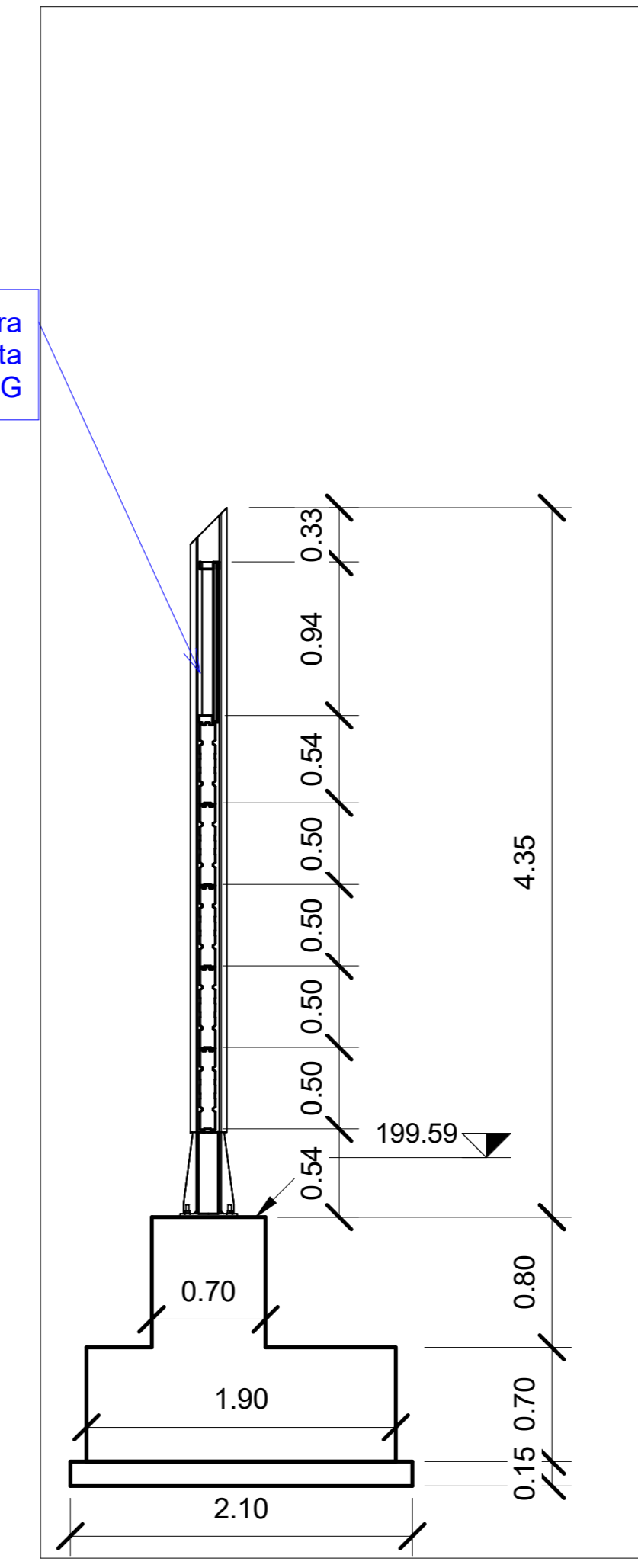

1 Stalcio Planimetrico WBS C.BA.19 pt.1
1 : 200

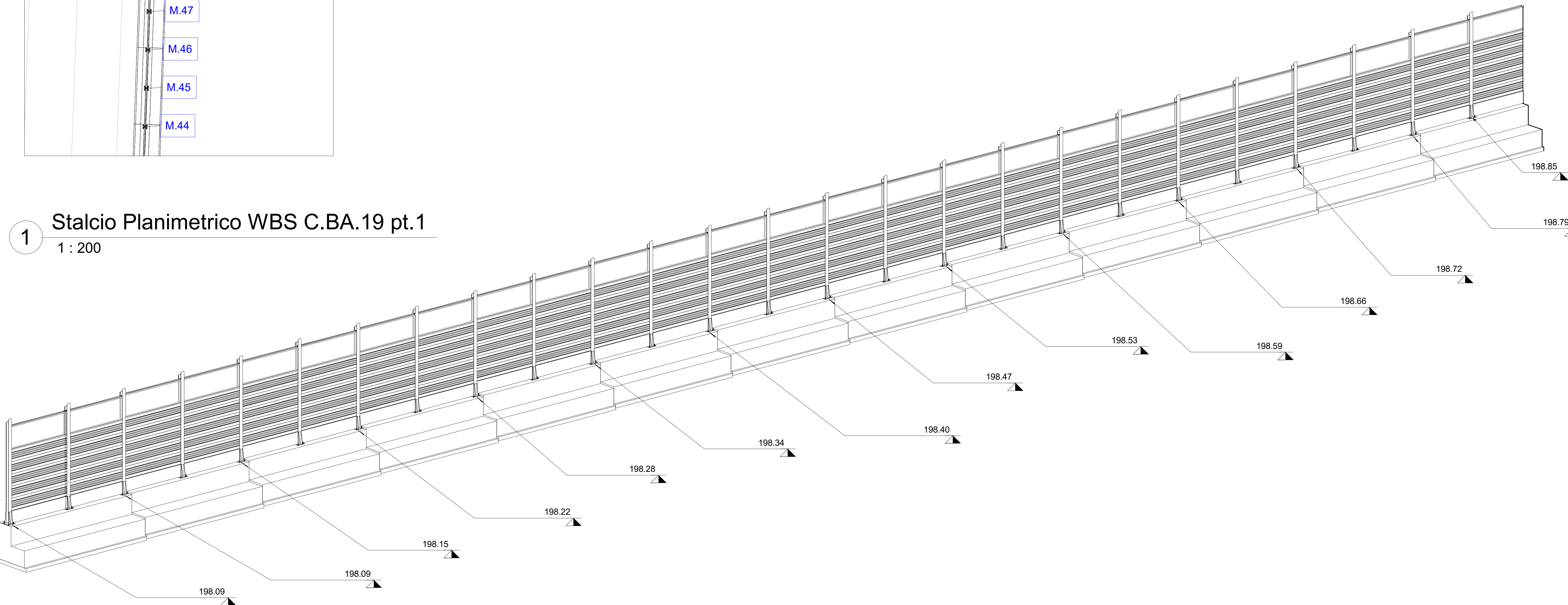

4 Assonometria WBS C.BA.19 pt.1



COLLEGAMENTO AUTOSTRADALE
DALMINE-COMO-VARESE-VALICO DEL GAGGIOLO E OPERE AD ESSO CONNESSE
CODICE C.U.P. F118606027007
PROGETTO ESECUTIVO
TRATTA C
 WBS C.BA.19 pt1

IDENTIFICAZIONE ELABORATO		CONTRAENTE GENERALE	
FASE PROGETTUALE	WBS	PEDELOMBARDA NUOVA S.c.p.A.	
AMBITO	TRATTA	DATA	REVISIONE
CATEGORIA	OPERA	A00	
PROGETTISTI	RESPONSABILE	ELABORAZIONE PROGETTUALE	
Erre Via S.r.l.	Ing. Alberto Rinaldi	PROGETTISTI	INGEGNERIA
CONCEDIENTE	CONCSSIONARIO	Ing. Andrea Marzulli	Ing. Carlo Listori
CONCEDIENTE	CONCSSIONARIO	Ing. Andrea Marzulli	Ing. Enrico Moretti
CONCEDIENTE	CONCSSIONARIO	Ing. Enrico Moretti	Ing. Enrico Moretti