

1 Stalcio Planimetrico WBS C.BA.57 pt.6  
1 : 200

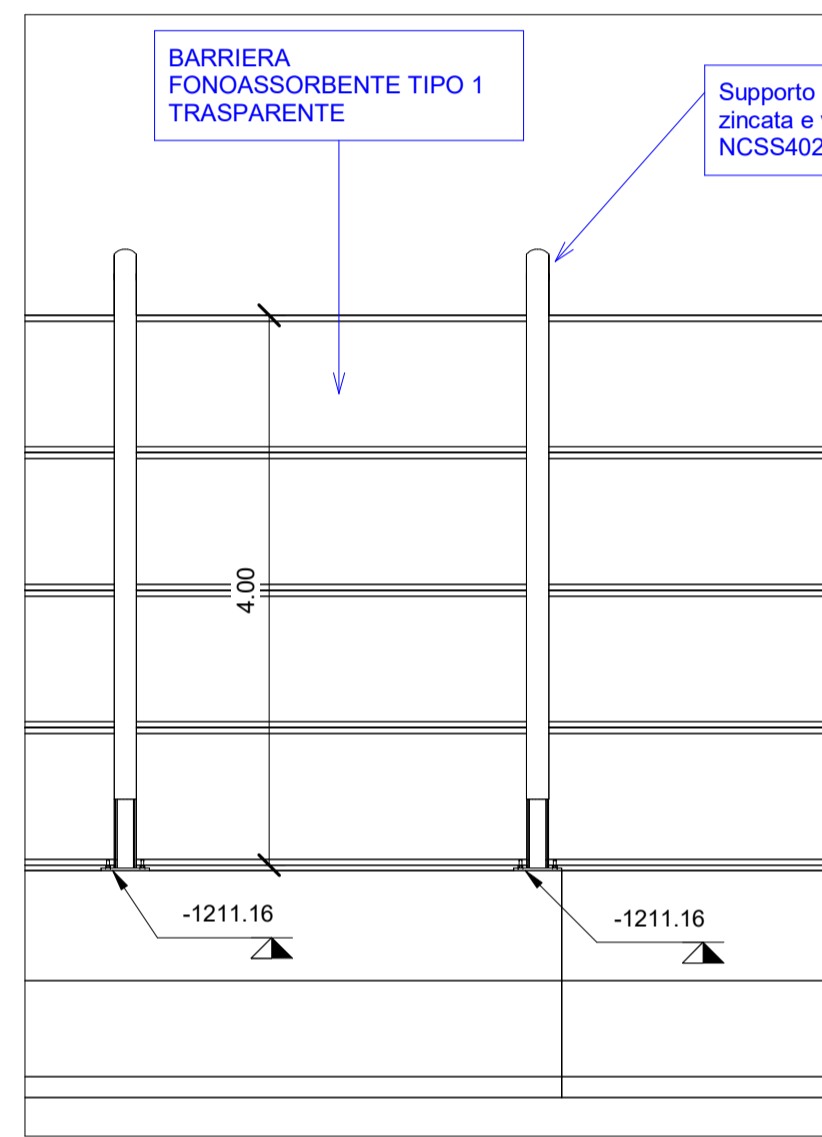

2 Sezione tipologica  
1 : 50

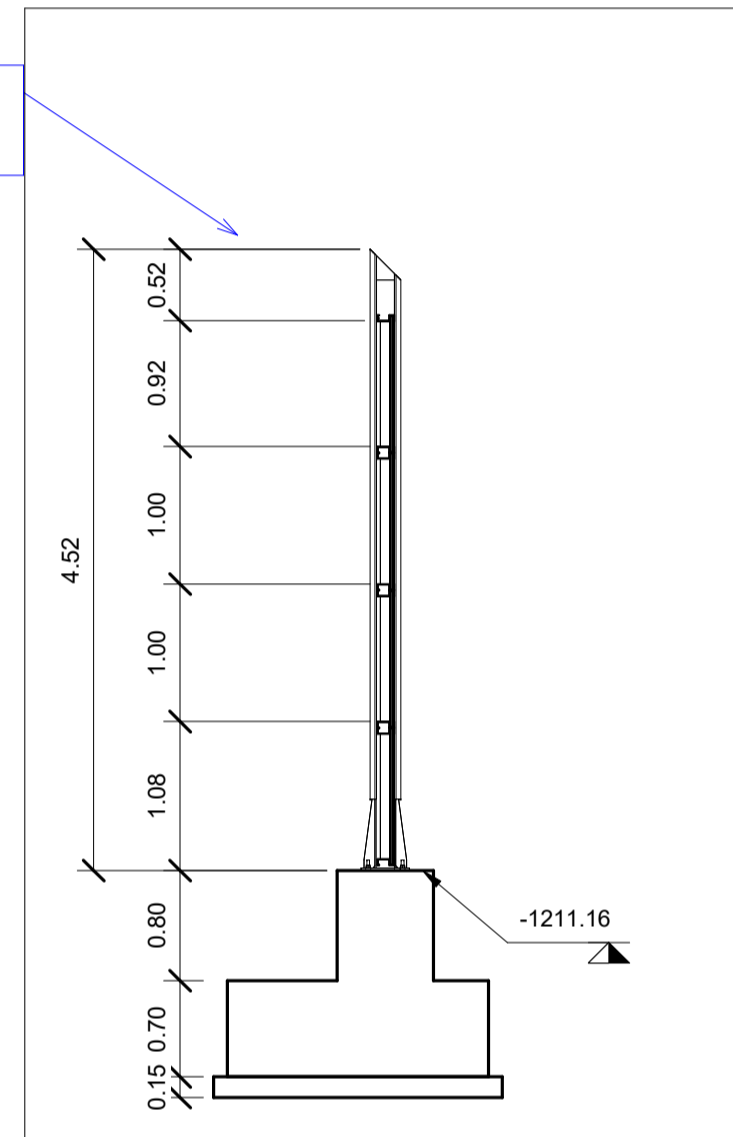

3 Sezione tipologica  
1 : 50

Abaco Coordinate di Tracciamento - Oper...			
P.01	E	N	
M.233	159243.863661	241627.421674	
M.234	159246.802541	241628.024153	
M.235	159249.741422	241628.626633	
M.236	159252.682474	241629.218418	
M.237	159255.623766	241629.809521	
M.238	159258.566535	241630.392708	
M.239	159261.509197	241630.975925	
M.240	159264.453212	241631.552793	
M.241	159267.397075	241632.130517	
M.242	159270.360032	241632.600503	
M.243	159273.324073	241633.071380	
M.244	159276.308507	241633.454842	
M.245	159279.285257	241633.827407	
M.246	159282.278380	241634.030416	
M.247	159285.272489	241634.233165	
M.248	159288.265961	241634.423492	
M.249	159291.259423	241634.613994	

Abaco Coordinate di Tracciamento - Oper...			
P.01	E	N	
M.250	159309.167611	241635.063937	
M.251	159312.131981	241635.524930	
M.252	159315.097281	241635.986067	
M.253	159318.061651	241636.447060	
M.254	159321.026020	241636.908053	
M.255	159323.990389	241637.369046	
M.256	159326.954759	241637.830039	
M.257	159329.919128	241638.291031	
M.258	159332.878658	241638.751272	
M.259	159335.843027	241639.212264	
M.260	159338.819836	241639.675192	
M.261	159306.203242	241634.602944	
M.262	159303.238872	241634.141951	
M.263	159300.239217	241634.191688	
M.264	159297.239873	241634.249739	
M.265	159294.245414	241634.432110	

Abaco Coordinate di Tracciamento - Oper...			
P.01	E	N	
M.348	159341.784205	241640.136185	
M.349	159344.748575	241640.597177	

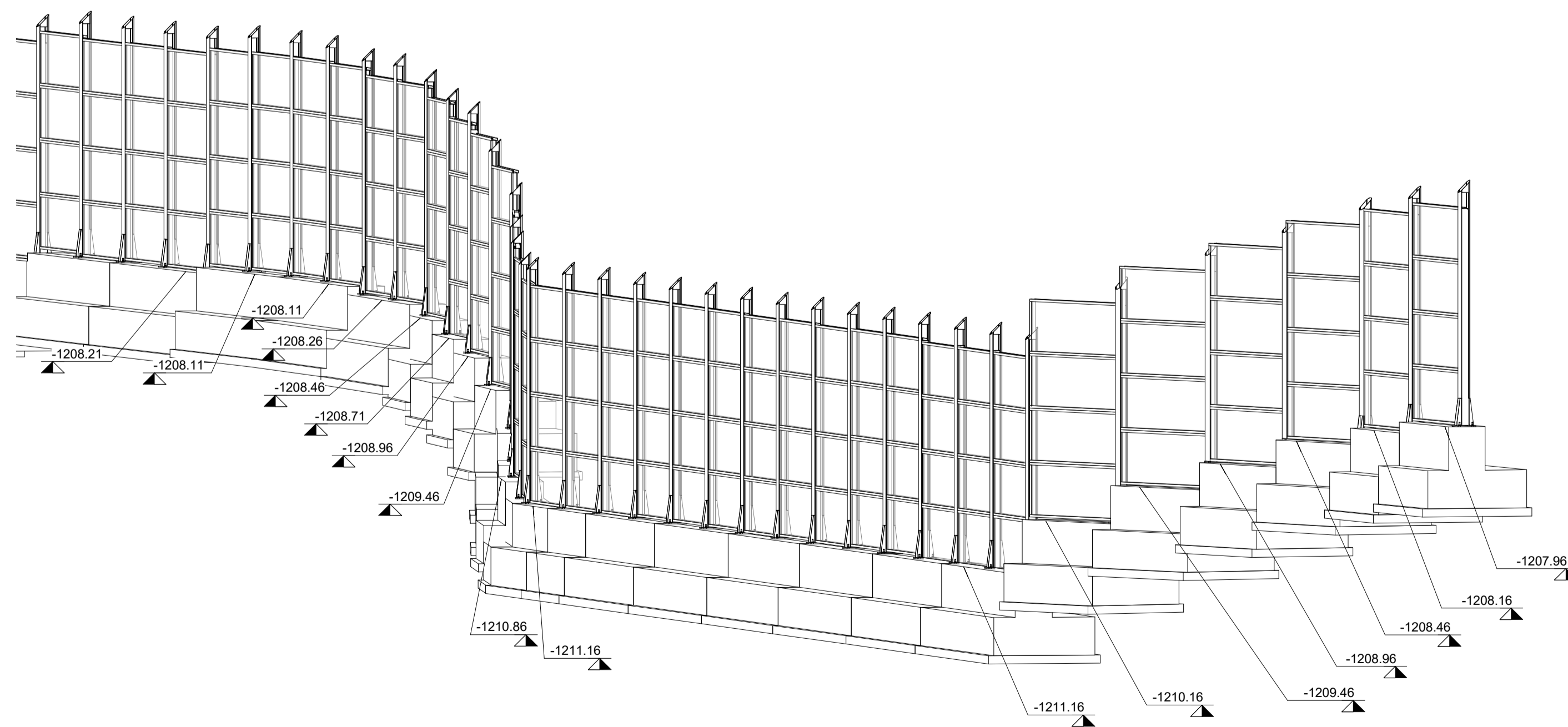
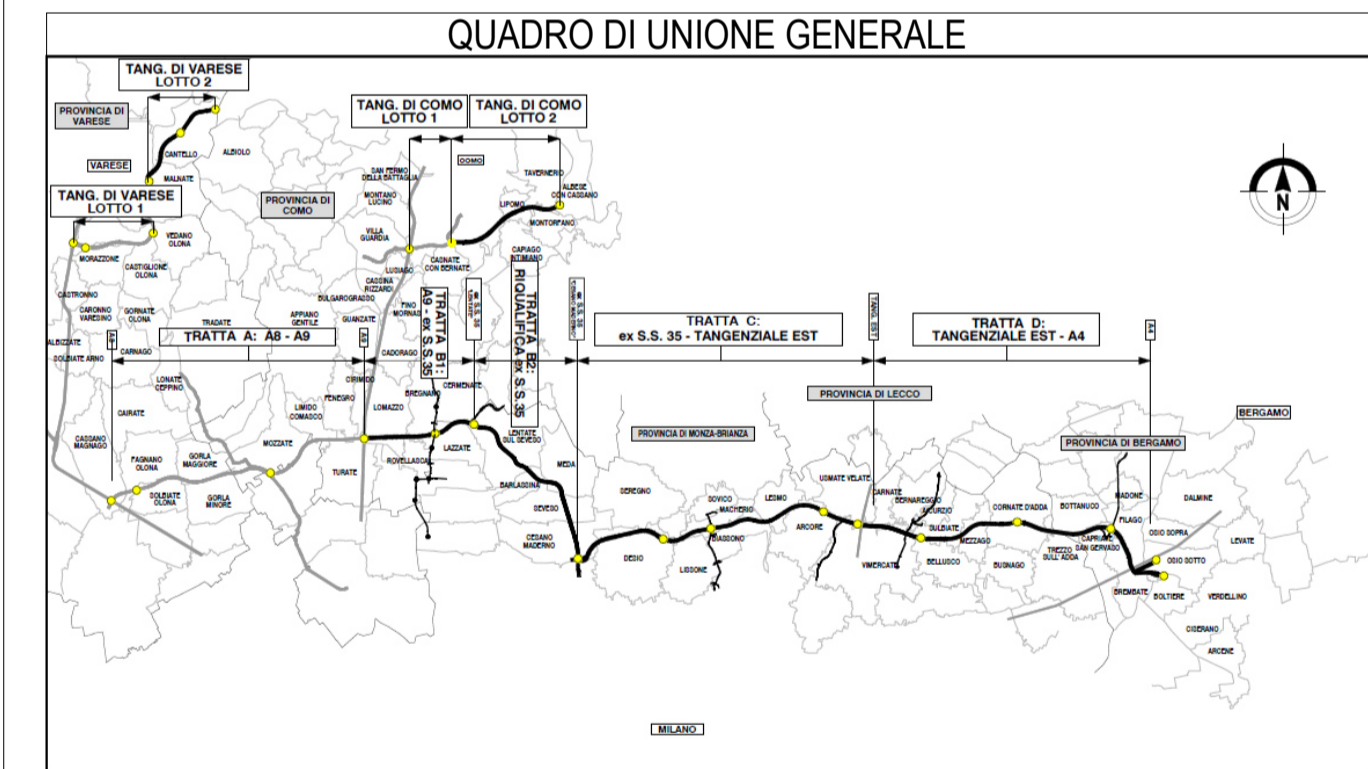
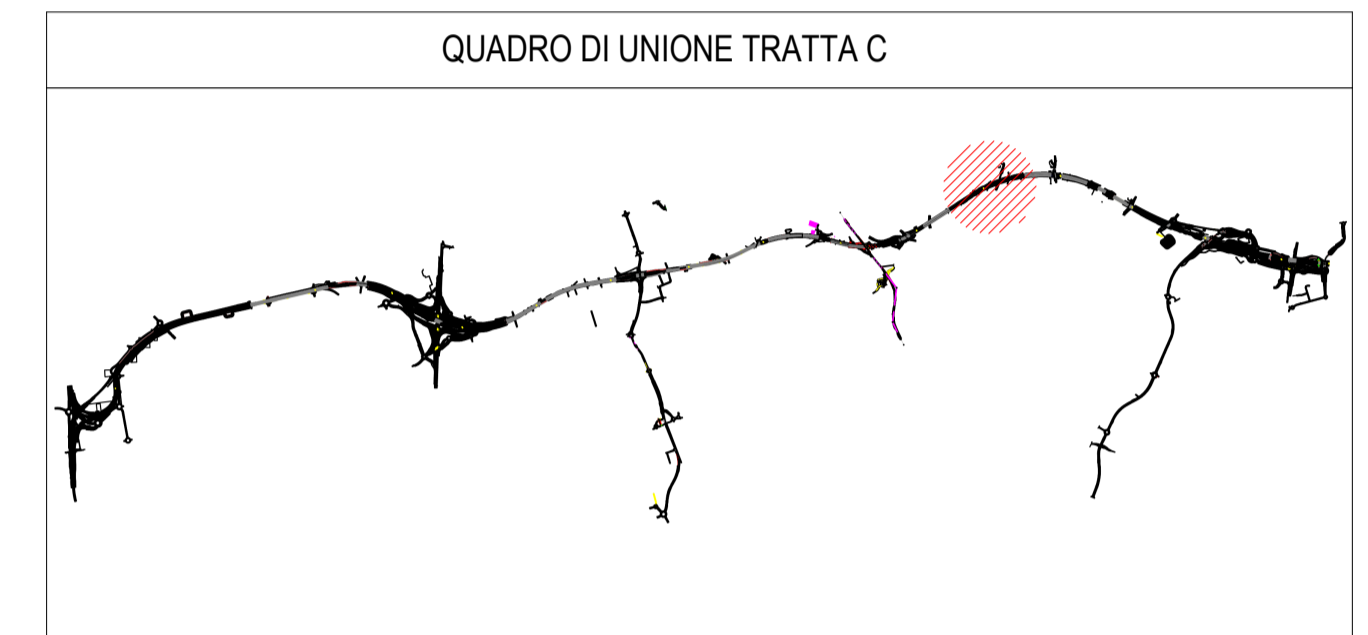
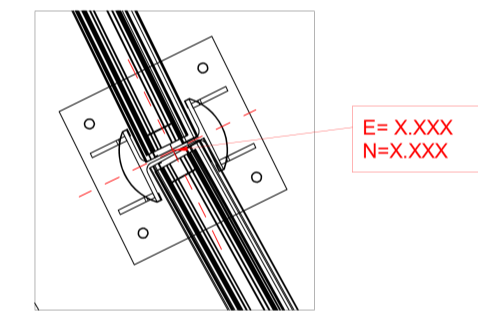

4 Assonometria WBS C.BA.57 pt.6

CONCESSIONARI  
AUTOSTRADALI  
LOMBARDE

Autosole  
Pedemontana  
Lombarda

**COLLEGAMENTO AUTOSTRADALE  
DALMINE-COMO-VARESE-VALICO DEL GAGGILO E OPERE AD ESSO CONNESSE**  
CODICE C.U.P. F1186000270007

**PROGETTO ESECUTIVO  
TRATTA C  
WBS C.BA.57 pt6**

<b>IDENTIFICAZIONE ELABORATO</b> FASE PROGETTUALE: AMBITO TRATTA CATEGORIA OPERA AMB CC		<b>CONTRAENTE GENERALE</b> <b>PEDELOMBARDA NUOVA S.c.p.A.</b>	
<b>CONCEDENTE</b> CONCESSIONARI AUTOSTRADALI LOMBARDE		<b>CONCESSIONARIO</b> Autosole Pedemontana Lombarda	
<b>PROGETTISTA</b> Ing. Alberto Rinaldi Erre Via A. S.r.l.		<b>PROGETTISTI</b> RESPONSABILE INTEGRAZIONE PRESTAZIONI SPECIALISTICHE Ing. Carlo Lisori	
DATA: 15/09/2023 SCALA: As indicated		DATA REVISIONE: 15/09/2023 A00 RESPONSABILE REVISIONE: A00	

Il presente documento non potrà essere copiato, riprodotto o altrimenti pubblicato in tutto o in parte senza il consenso scritto di Autosole Pedemontana Lombarda S.p.A. Ogni utilizzo non autorizzato sarà perseguito a norma di legge. This document may not be copied, reproduced or published either in part or entirely without the written permission of Autosole Pedemontana Lombarda S.p.A. Unauthorized use will be prosecuted by law.