



REGIONE
CAMPANIA



PROVINCIA
DI
BENEVENTO



COMUNE DI
CASTELFRANCO IN
MISCANO





PROVINCIA
DI
AVELLINO



COMUNE DI
ARIANO IRPINO

PROGETTO DEFINITIVO PER LA REALIZZAZIONE DI UN PARCO EOLICO DA 34 MW NEL COMUNE DI CASTELFRANCO IN MISCANO (BN) , CON OPERE DI CONNESSIONE IN CASTELFRANCO IN MISCANO (BN) E ARIANO IRPINO (AV)



<p>Proponente</p>	 <p>DMA LUCERA SRL Largo Augusto n.3 20122 Milano pec:dmalucera@legalmail.it</p>   				
<p>Progettazione</p>	 <p>Viale Michelangelo, 71 80129 Napoli TEL.081 579 7998 mail: tecnico.inse@gmail.com</p> <p>Amm. Francesco Di Maso Ing. Nicola Galdiero Ing. Pasquale Esposito</p> <p>Collaboratori: Geol. V.E. Iannolino Dott.Agr. A. Ianiro Archeol. A.Vella Ing. V. Triunfo Arch. C. Gaudiero Ing. F.Quarto Arch. M. Mauro Geotecnica Meridionale Srl</p>				
<p>Elaborato</p>	<p>Nome Elaborato:</p> <p style="text-align: center;">SCHEDA TECNICA WTG N131</p>				
<p>00</p>	<p>08-10-2023</p>	<p>PRIMA EMISSIONE</p>	<p>INSE Srl</p>	<p>INSE Srl</p>	<p>DMA Lucera Srl</p>
<p>Rev.</p>	<p>Data</p>	<p>Oggetto della revisione</p>	<p>Elaborazione</p>	<p>Verifica</p>	<p>Approvazione</p>
<p>Scala: -:-</p>					
<p>Formato: A4</p>	<p>Codice Pratica</p>	<p style="text-align: center;">S252</p>	<p>Codice Elaborato</p>	<p style="text-align: center;">AS252-INT II-07-R</p>	

General documentation

Technical description

Wind turbine class K08 delta

N131/3900 IEC S



E0003806613

Revision 06 / 2019-04-08

- Translation of the original document (E0003696129, rev. 9) -
This is a translation from German. In case of doubt, the German text shall prevail.
Document is published in electronic form.
Original document at Nordex Energy GmbH, Engineering department.

This document has been created by Nordex Energy GmbH and/or an affiliated company as defined in section 15 et seq. of the German Stock Corporation Act (AktG).

This document, including any presentation of its contents in whole or in parts, is the intellectual property of Nordex Energy GmbH and/or affiliated companies as defined in section 15 et seq. of the German Stock Corporation Act (AktG). All information contained in this document is confidential and must never (not even in extracts) be disclosed to third parties without the prior written approval of Nordex Energy GmbH.

All rights reserved.

Any disclosure, duplication, translation or other use of this document or parts thereof, regardless if in printed, handwritten, electronic or other form, without the explicit approval of Nordex Energy GmbH is prohibited.

Copyright 2019 by Nordex Energy GmbH.

Contact details

For questions relating to this documentation please contact:

Nordex Energy GmbH

Langenhorner Chaussee 600

22419 Hamburg

Germany

Phone: +49 (0)40 300 30 -1000

Fax: +49 (0)40 300 30 -1101

<http://www.nordex-online.com>

info@nordex-online.com

1. Structure

The Nordex N131/3900 wind turbine (WT) is a speed-variable wind turbine with a rotor diameter of 131.0 m and a nominal power of 3900 kW. It is offered in variants for 50 Hz and 60 Hz. The wind turbine is designed for class IIIS in accordance with IEC 61400-1.

The wind turbine consists of the following main components:

- Rotor, with rotor hub, three rotor blades and pitch system
- Nacelle with drive train, generator and yaw system
- Tubular tower with foundation or hybrid tower with foundation
- Medium-voltage transformer (MV transformer) and medium-voltage switchgear (MV switchgear)

1.1 Tower

The Nordex N131/3900 is erected on tubular steel towers or hybrid towers with different hub heights. The cylindrical steel tower has a conical head section and consists of 2 to 6 sections. Corrosion protection is guaranteed by a coating system of the surface in accordance with ISO 12944. A service lift, the vertical ladder with fall protection system as well as resting and working platforms inside the tower allow for a weather-protected ascent to the nacelle. The lower part of the hybrid tower consists of a concrete part on which the two steel sections are mounted.

The size and design of the foundation depend on the ground conditions at the intended site. The tubular steel tower is bolted to the anchor cage embedded in the foundation.

Switch cabinets are integrated in the tower base, which contain important components of the electronic controls, the turbine PC, frequency converter, low-voltage main switch, fuses, the transformer for auxiliary power in the tower base and outputs to the transformer and to the generator. The frequency converter is equipped with a water cooling system. The water heated in the frequency converter is cooled in a water/air heat exchanger. It is located on the outer tower wall.

The MV transformer and MV switchgear may be located in a separate transformer substation near the wind turbine. For the transformer in the tower (TIT) variant, the MV transformer and MV switchgear can also be located in the tower base.

In this case, the components in the tower base of the tubular steel tower are arranged on three different levels:

- The MV transformer on the foundation
- The MV switchgear on the first tower platform
- The switch cabinet with frequency converter on the second tower platform

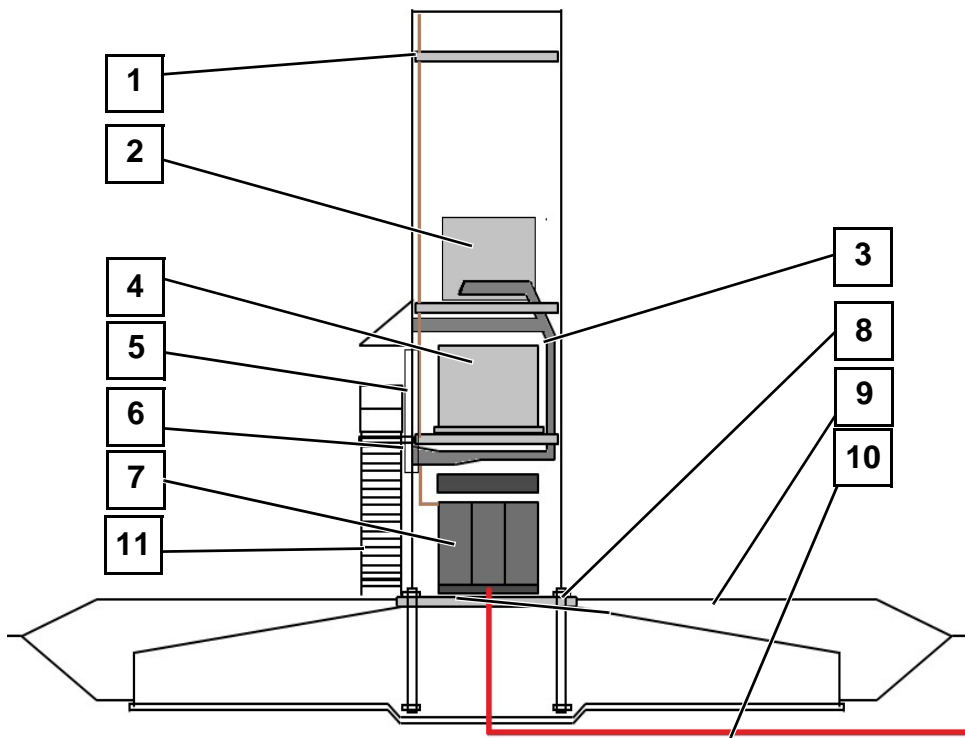

Fig. 1 Section through the tower base, transformer inside tower (TIT) variant

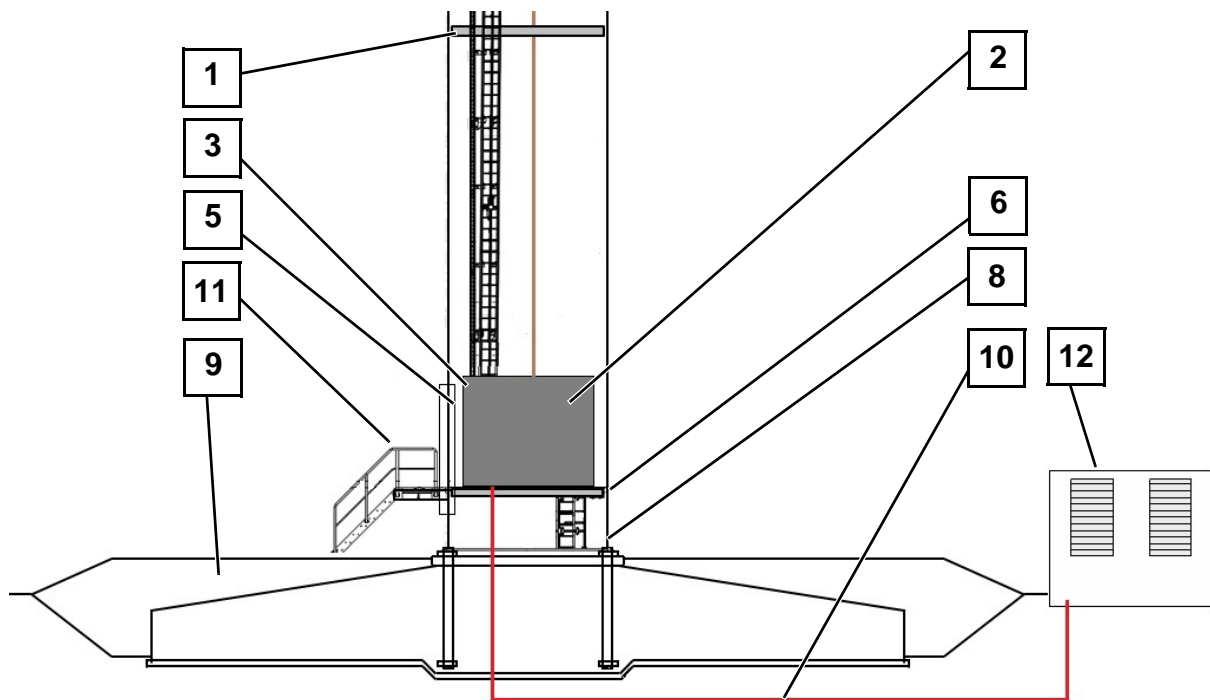

Fig. 2 Section through the tower base, transformer outside tower (TAT) variant

- | | | |
|-----------------------------|----------------------------|--|
| 1 Flange tower platform | 2 Switch cabinet/converter | 3 Ventilation/cooling |
| 4 MV switchgear (TIT) | 5 Tower door | 6 First tower platform |
| 7 Transformer (TIT) | 8 Anchor bolts | 9 Soil backfill |
| 10 Power cables in conduits | 11 Tower stairs | 12 Transformer station with switchgear (TAT) |

The hybrid tower is only available in the transformer in the tower variant. All tower base interiors are installed on one level.

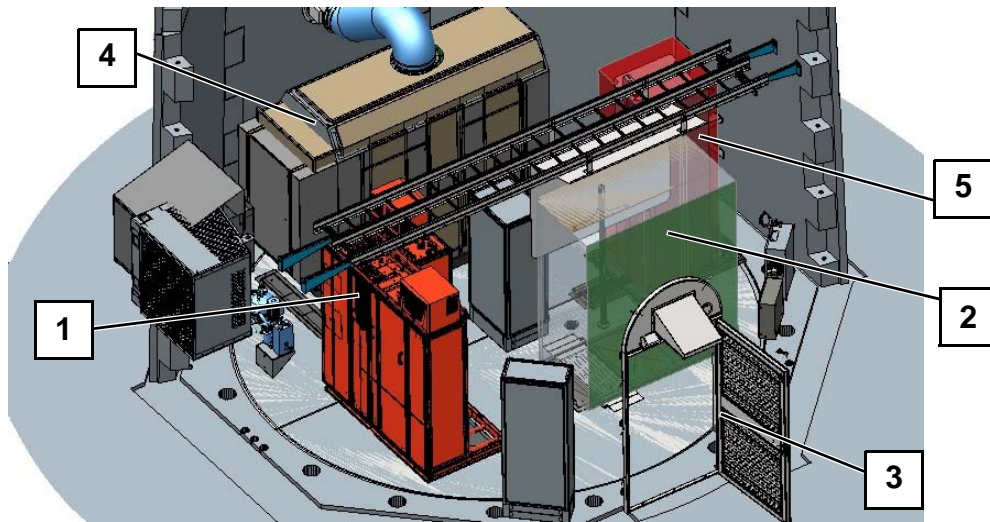

Fig. 3 Hybrid tower base

- | | | |
|------------------|-----------------|----------------|
| 1 Main converter | 2 MV switchgear | 3 Tower access |
| 4 MV transformer | 5 Service lift | |

1.2 Rotor

The rotor consists of the rotor hub with three pitch bearings and three pitch drives for blade adjustment as well as three rotor blades.

The **rotor hub** consists of the base element, support structure and spinner. The base element consists of a stiff cast structure, on which the pitch bearings and the rotor blades are assembled. The rotor hub is covered with a spinner which enables direct access from the nacelle into the rotor hub.

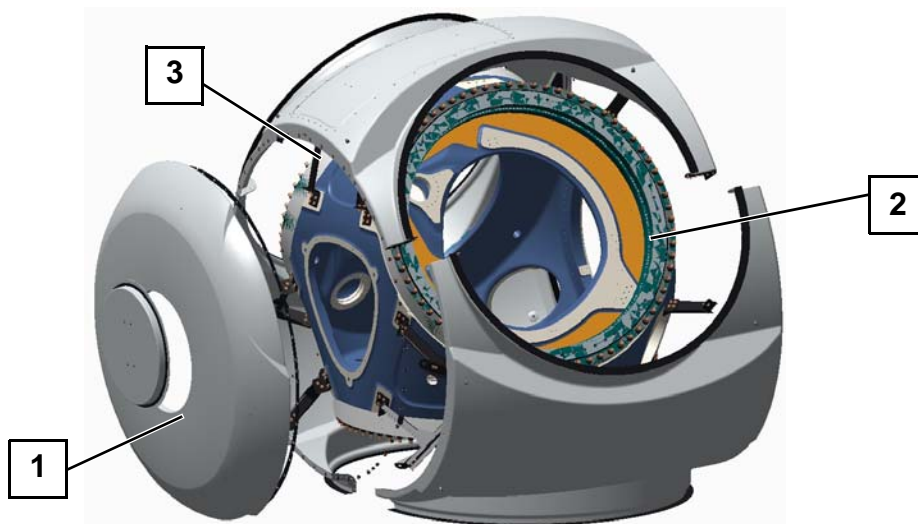

Fig. 4 Rotor hub and spinner of Nordex delta generation wind turbines

- | | | |
|-------------------|-------------|-----------------------------|
| 1 Spinner segment | 2 Rotor hub | 3 Spinner support structure |
|-------------------|-------------|-----------------------------|

The **rotor blades** are made of high-quality glass fiber-reinforced and carbon fiber-reinforced plastics. The rotor blade is statically and dynamically tested in accordance with the guidelines IEC 61400-23 and GL IV-1 (2010). If requested by the customer, the rotor blades can be equipped with serrations, which optimize the sound power level.

The **pitch system** serves to adjust the pitch angle of the rotor blades set by the control system. For each individual rotor blade the pitch system comprises an electromechanical drive with 3-phase motor, planetary gear and drive pinion, as well as a control unit with frequency converter and emergency power supply. Power supply and signal transfer are realized through a slip ring in the nacelle.

1.3 Nacelle

The nacelle contains essential mechanical and electrical components of the wind turbine. The nacelle can be pivoted on the tower.

The **rotor shaft** is supported in the rotor bearing inside the nacelle. A rotor lock is integrated in the rotor bearing, with which the rotor can be reliably locked in place mechanically.

The **gearbox** increases the rotor speed until it reaches the speed required for the generator.

The bearings and gearings are continuously lubricated with oil. A 2-stage pump enables the oil circulation. A combination filter element with coarse, fine and ultrafine filter retains solid particles. The control system monitors the contamination of the filter element.

The gear oil used for lubrication also cools the gearbox. The temperatures of the gearbox bearings and the oil are continuously monitored. If the optimum operating temperature is not yet reached, a thermal bypass directs the gear oil directly back to the gearbox. If the operating temperature of the gear oil is exceeded it is cooled down.

The gearbox cooling is realized with an oil/water cooler that is installed directly at the gearbox. The heated cooling water is re-cooled together with the cooling water of the generator in a passive cooler on the nacelle roof.

The **generator** is a 6-pole doubly-fed induction machine. An air/water heat exchanger is mounted on the generator. The cooling water is re-cooled together with the cooling water of the gearbox heat exchanger in a passive cooler on the nacelle roof.

The mechanical **rotor brake** supports the aerodynamic braking effect of the rotor blades as soon as the rotor speed falls below a defined value and finally stops the rotor. The aerodynamic braking effect of the rotor is achieved by adjusting the rotor blades perpendicular to the rotation direction. The rotor brake consists of a brake caliper, which acts on the brake disk assembled behind the gearbox.

The **yaw drives** optimally rotate the nacelle into the wind. The four yaw drives are located on the machine frame in the nacelle. A yaw drive consists of an

electric motor, multi-stage planetary gear, and a drive pinion. The drive pinions mesh with the external teeth of the yaw bearing.

When positioned properly, the nacelle is locked by means of a hydraulic and an electric brake system. It consists of several brake calipers which are fastened to the machine frame and act on a brake disk. In addition, the electric motors of the yaw drives are equipped with an electrically actuated holding brake.

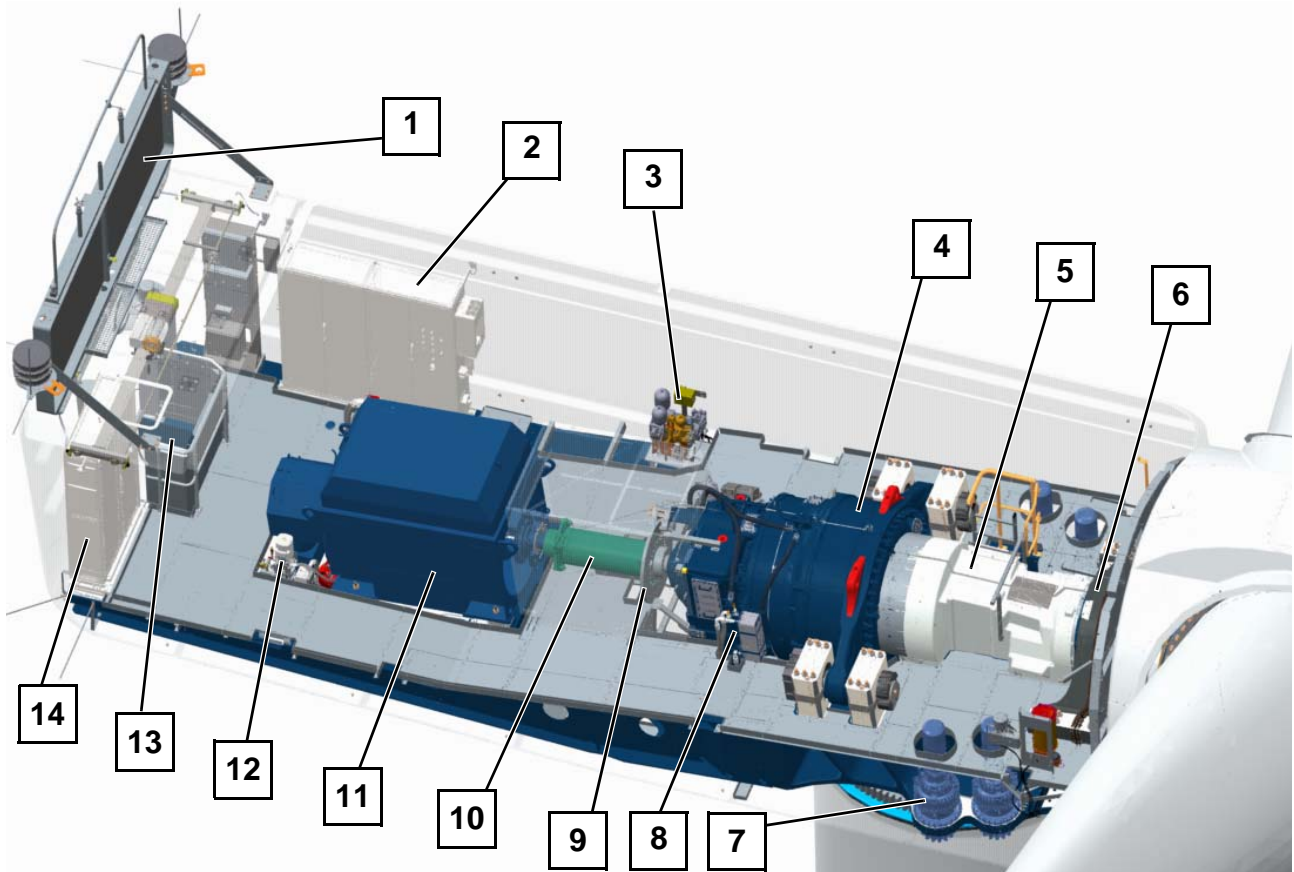

Fig. 5 Nacelle layout drawing

- | | | | |
|----|--------------------------------|----|-----------------|
| 1 | Heat exchanger | 2 | Topbox |
| 3 | Hydraulic unit | 4 | Gearbox |
| 5 | Rotor shaft | 6 | Rotor bearing |
| 7 | Yaw drives | 8 | Gear oil cooler |
| 9 | Rotor brake | 10 | Coupling |
| 11 | Generator | 12 | Coolant pump |
| 13 | Hatch for electric chain hoist | 14 | Transformer box |

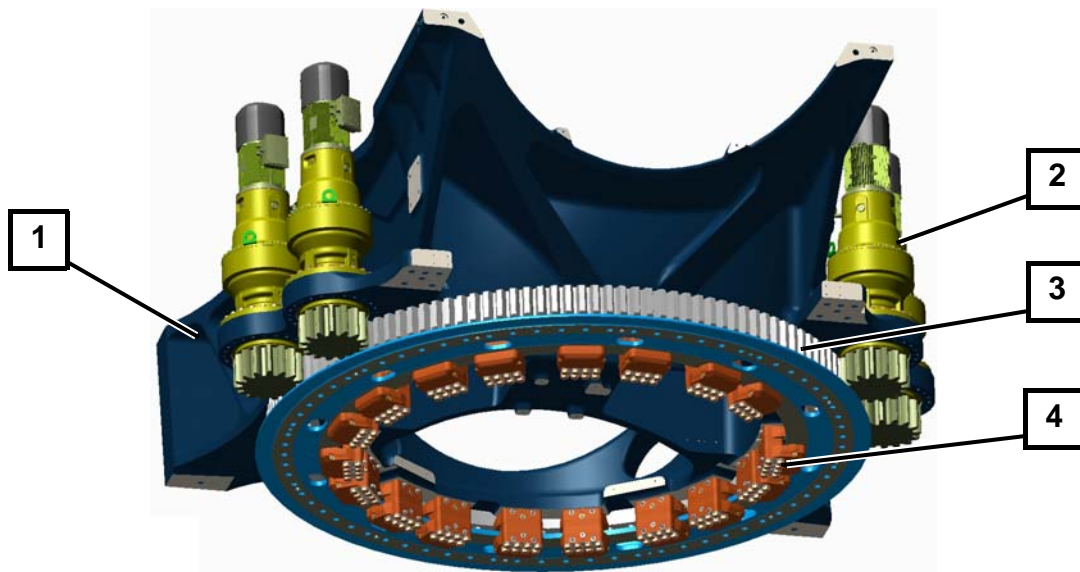

Fig. 6 Components of the yaw system

1	Machine frame	2	Yaw drives
3	Yaw bearing	4	Brake calipers

The **hydraulic unit** provides the oil pressure required for the operation of the rotor brake and the yaw brakes.

1.4 Auxiliary systems

Rotor bearing, generator bearing, gearing of the pitch bearings and gearing of the yaw bearing are each equipped with an **automatic lubrication system**. An automatic raceway lubrication of the pitch bearings can be offered as an option.

The switch cabinets in the nacelle and the tower base of the wind turbine are in part equipped with **air conditioning units**.

Gearbox, generator, hydraulic unit and all switch cabinets are equipped with **heaters**.

An **electric chain hoist** is installed in the nacelle which is used for lifting tools, components and other work materials from the ground into the nacelle. An **overhead lifting beam incl. push trolley** is used in connection with a manual chain hoist for moving the materials within the nacelle. The manual chain hoist is not included in the standard scope of supply of the WT, but can be offered as an option.

Various options of additional equipment are available for the wind turbine.

Cooling system

Gearbox and generator are cooled by a coupled oil/water circulation. At startup the lightly heated gear oil is directly fed back into the gearbox via a thermal bypass and only directed into the plate-type heat exchanger after reaching operating temperature.

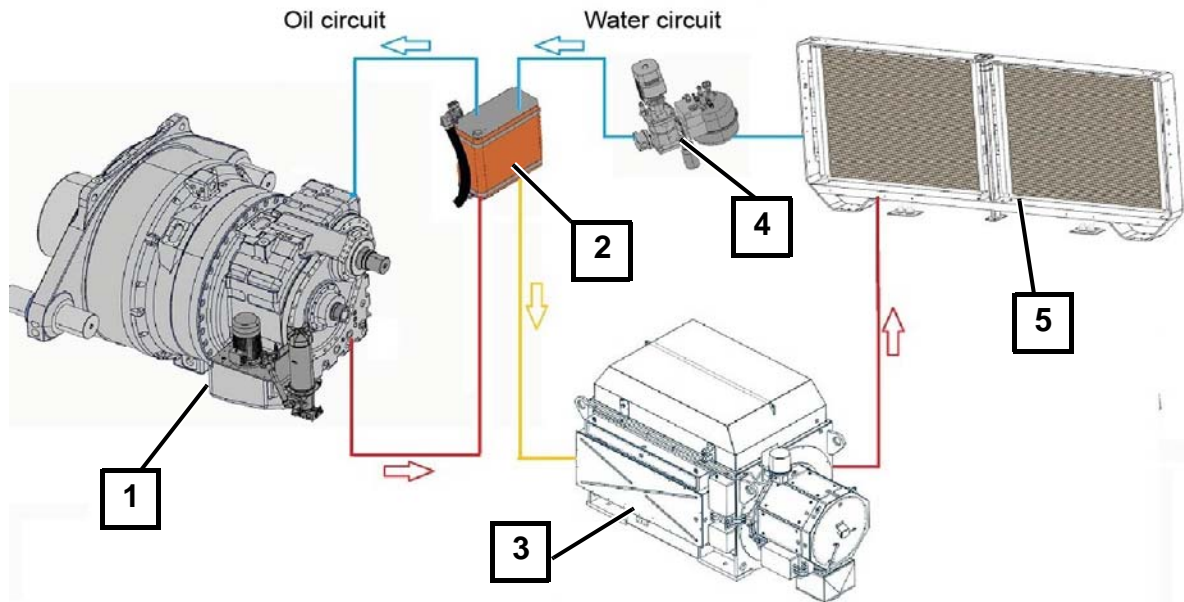

Fig. 7 Schematic diagram of gearbox cooling and generator cooling

- 1 - Gearbox with oil pump
- 2 - Plate-type heat exchanger
- 3 - Generator
- 4 - Water pump
- 5 - Passive coolers

The converter in the tower base is cooled by a water/glycol mixture. A pump conveys the mixture through the main converter and the heat exchanger. The heat exchanger is equipped with a 2-stage fan that is operated depending on the water temperature.

2. Function

The turbine operates automatically. A programmable logic controller (PLC) continuously monitors the operating parameters using various sensors, compares the actual values with the corresponding setpoints and issues the required control signals to the WT components. The operating parameters are specified by Nordex and are adapted to the individual location.

When there is no wind the WT remains in idle mode. Only various auxiliary systems are operational or activated as required: e.g., heaters, gear lubrication or PLC, which monitors the data from the wind measuring system. All other systems are switched off and do not use any energy. The rotor idles. When the cut-in wind speed is reached, the wind turbine will change to the mode 'Ready for operation'. Now all systems are tested, the nacelle turns into the wind and the rotor blades turn into the wind. When a certain speed is reached, the generator is connected to the grid and the WT produces energy.

At low wind speeds the WT operates at part load. During this the rotor blades remain fully turned into the wind (pitch angle 0°). The power produced by the WT depends on the wind speed.

When the nominal wind speed is reached, the WT switches over to the nominal load range. If the wind speed continues to increase, the speed control changes the rotor blade angle so that the rotor speed and thus the power output of the WT remain constant.

The yaw system ensures that the nacelle is always optimally aligned to the wind. To this end, two separate wind measuring systems located at the height of the hub measure the wind direction. Only one wind measuring system is used for the control system, while the second system monitors the first and takes over in case the first system fails. If the measured wind direction deviates too greatly from the alignment of the nacelle, the nacelle is yawed into the wind.

The wind energy absorbed from the rotor is converted into electrical energy using a double-fed asynchronous generator with slip ring rotor. Its stator is directly connected to the MV transformer, and its rotor via a specially controlled frequency converter. This offers a significant advantage enabling the generator to be operated in a defined speed range near its synchronous speed.

Safety systems

Nordex wind turbines are equipped with extensive equipment and accessories to provide for personal and turbine safety and ensure continuous operation. The entire turbine is designed in accordance with the Machinery Directive 2006/42/EC and certified as per IEC 61400. For details on the safety devices refer to the current safety manual.

If certain parameters concerning turbine safety are exceeded, the WT will cut out immediately and is put into a safe state. Depending on the cut-out cause, different brake programs are triggered. In case of external causes, such as excessive wind speeds or if the operating temperature is not met, the wind turbine is softly braked by means of rotor blade adjustment.

Lightning protection/surge protection and electromagnetic compatibility (EMC)

The lightning/surge protection of the wind turbine is based on the EMC-compliant lightning protection zone concept, which comprises the implementation of internal and external lightning/surge protection measures under consideration of the standard IEC 61400-24.

The wind turbine falls into lightning protection level I. All components of the internal and external lightning/surge protection are designed in accordance with lightning protection level I.

The wind turbine with the electrical equipment, consumers, the measurement, control, regulating, protection, information and telecommunication technology meets the EMC requirements in accordance with IEC 61400-1, item 10.11.

Low-voltage grid types

The **660 V low voltage network** as an IT network configuration and three phase rotary current network is insulated against ground and is the primary low voltage energy system of the wind turbine. The bodies of the electrical equipment and measuring instruments of this network are grounded directly or by means of separate protective bonding conductors. As a further protection measure for personal and turbine protection in the 660 V IT network a central insulation monitor has been installed.

The **400 V/230 V low-voltage network** has its neutral point grounded directly at the supplying network transformers as TN system and three-phase system. The equipment grounding conductor PE and the neutral conductor are available separately. The bodies of the electrical equipment and consumers are connected directly and straight to the neutral points of the supplying grid transformers via equipment grounding conductors, including the protective equipotential bonding. The 400 V/230 V low voltage network is the auxiliary low voltage system of the wind turbine.

Auxiliary power of the wind turbine

The auxiliary low voltage required by the wind turbine in stand-by mode and feed-in mode is requested by the following consumers:

- Wind turbine control including main converter control
- 400 V/230 V auxiliary power of the main converter
- 230 V AC UPS supply including 24 V DC supply
- Yaw system
- Pitch system
- Hydraulic unit
- Auxiliary drives such as pumps, fans and lubrication units
- Heaters, AC units, lighting

- Auxiliary systems such as service lift, obstacle lights
- Optional systems

Based on measurements, simulations and existing operating experience, a coincidence factor of 0.6 can be estimated for the installed low voltage auxiliary power for the worst load case of the auxiliary low voltage system as well as the feed-in operation mode of the WT. In the worst load case as well as in stand-by mode of the WT, a coincidence factor of 0.2 is estimated. In addition, measurements and simulations show that the average power factor ($\cos \phi$) at the supply points of the auxiliary low voltage system does not permanently fall below approx. 0.97 in any WT operating point/load case.

Long-term measurements show that the average base load (average active power) of the auxiliary low voltage system during WT feed-in operation mode is approx. 15 kW, based on one year.

For locations with an average annual speed of 6.5 m/s, approx. 10,000 kWh auxiliary consumption arises, however, this value is greatly dependent on location. Auxiliary consumption is defined as the energy consumption of the WT from the grid for a period during which the WT does not supply current to the grid.

3. Technical data

Design	
Design temperature	Default: -20 °C to +45 °C CCV: -40 °C to +45 °C
Operating temperature range	-20 °C to +40 °C*
Operating temperature range CCV	-30 °C to +40 °C*
Stop	Default: -20 °C, restart at -18 °C CCV: -30 °C, restart at -28 °C
Max. height above MSL	2000 m**
Certificate	In accordance with IEC 61400-1
Type	3-blade rotor with horizontal axis Up-wind turbine
Output control	Active single blade adjustment
Nominal power ^{*/**}	3900 kW
Nominal power starting at wind speeds of (at air density of 1.225 kg/m ³)	Approx. 12.0 m/s
Operating speed range of the rotor	7.9 to 14.4 min ⁻¹
Nominal speed	12.6 min ⁻¹
Cut-in wind speed	3.0 m/s
Cut-out wind speed	25.0 m/s ^{***}
Cut-back-in wind speed	19.5 m/s ^{***}
Calculated service life	At least 20 years

* Nominal power is reached up to defined temperature ranges. Limited project-specific operating ranges are possible and must be agreed to with Nordex.

** At installation altitudes above 1000 m, the nominal power is reached up to defined temperature ranges.

*** The cut-out wind speed can be set to 20 m/s (cut-back-in wind speed: 19.5 m/s) on a project-specific basis.

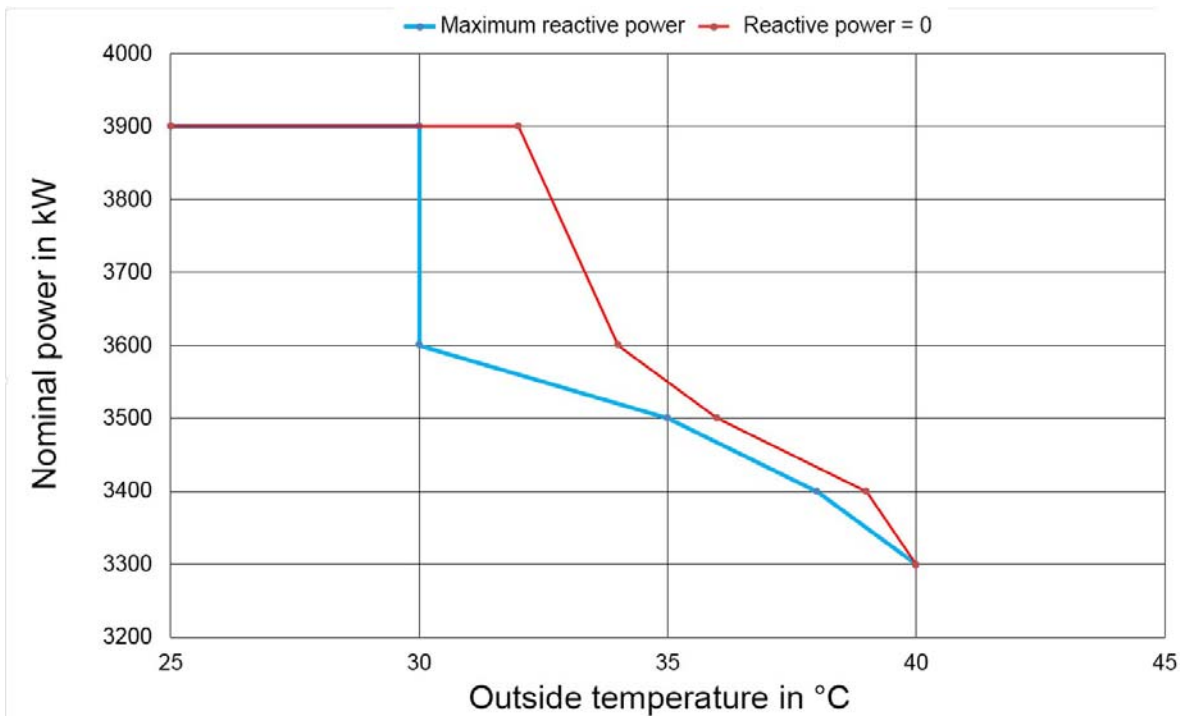

Fig. 8 Power adjustment depending on reactive power and temperature (up to a height of ≤ 1000 m above MSL)

Towers	TS84	TS114	TS120	TS134	TCS134
Hub height	84 m	114 m	120 m	134 m	134 m
Wind class	DIBt S IEC IIIS	IEC S	DIBt S IEC IIIS	DIBt S IEC IIIS	DIBt S
Number of tower sections	3	5	5	6	Concrete part + 2 steel sections

Rotor	
Rotor diameter	131.0 m
Swept area	13478 m ²
Nominal power/area	289.4 W/m ²
Rotor shaft inclination angle	5 °
Blade cone angle	4.5 °

Rotor blade	
Material	Glass fiber-reinforced and carbon fiber-reinforced plastics

Rotor blade	
Total length	64.4 m
Total weight per blade	Max. 15.7 t

Rotor shaft/rotor bearing	
Type	Forged hollow shaft
Material	42CrMo4 or 34CrNiMo6
Bearing type	Spherical roller bearing
Lubrication	Continuous and automatic with lubricating grease
Rotor bearing housing material	EN-GJS-400-18-LT

Mechanical brake	
Type	Actively actuated disk brake
Location	On the high-speed shaft
Disk diameter	920 mm
Number of brake calipers	1
Brake pad material	Sintered metal

Gearbox	
Type	Multi-stage planetary gear + spur gear stage
Gear ratio	50 Hz: $i = 92.3$ 60 Hz: $i = 110.75$
Lubrication	Forced-feed lubrication
Oil type	VG 320
Max. oil temperature	75 °C
Oil change	Change, if required

Electrical system	
Nominal power P_{nG}^*	3900 kW
Nominal voltage	3 x AC 660 V \pm 10 % (specific to grid code)
Nominal current I_{nG} at S_{nG}^*	3795 A
Nominal apparent power S_{nG} at P_{nG}^*	4338 kVA

Electrical system	
Power factor at P_{nG}	1.00 as default setting 0.899 underexcited (inductive) up to 0.899 overexcited (capacitive) possible
Frequency	50 and 60 Hz

* All values are maximum values; values may vary depending on temperature and reactive power, see Fig. 8

Generator	
Degree of protection	IP 54 (slip ring box IP 23)
Nominal voltage	660 V
Frequency	50 and 60 Hz
Speed range	50 Hz: 730 to 1325 rpm 60 Hz: 876 to 1590 min ⁻¹
Poles	6
Weight	Approx. 10.6 t

Gearbox cooling and filtration	
Type	1st cooling circuit: Oil circuit with oil/water heat exchanger and thermal bypass 2nd cooling circuit: Water/air together with generator cooling
Filter	Coarse filter 50 μm / fine filter 10 μm / ultrafine filter <5 μm
Flow rate	Stage 1: approx. 75 l/min Stage 2: approx. 150 l/min

Generator cooling	
Type	Water circuit with water/air heat exchanger
Flow rate	Approx. 160 l/min
Coolant	Water/glycol-based coolant

Converter cooling	
Type	Water circuit with water/air heat exchanger and thermal bypass
Coolant	Water/glycol-based coolant

Pitch system	
Pitch bearing	Double-row four-point contact bearing
Lubrication of gearing and race	Regular lubrication with grease Optional: Automatic lubrication unit with grease
Drive	3-phase motor incl. spring-actuated brake and multi-stage planetary gear
Emergency power supply	Gel batteries

Hydraulic system	
Hydraulic oil	VG 32
Oil quantity	Approx. 25 L
Thermal protection	Integrated PT100

Yaw drive	
Motor	Asynchronous motor
Gearbox	4-stage planetary gear
Number of drives	4
Lubrication	Oil, ISO VG 150
Yaw speed	Approx. 0.5 °/s

Yaw brake	
1st type	Disk brake with hydraulic brake calipers
Brake pad material	Organic
Number of brake calipers	18
2nd type	Electric spring-applied brake on every driving motor

Nordex Energy GmbH
Langenhorner Chaussee 600
22419 Hamburg
Germany
<http://www.nordex-online.com>
info@nordex-online.com



Noise level, Power curves, Thrust curves

Nordex N131/3900 IEC S

© Nordex Energy SE & Co. KG, Langenhorner Chaussee 600, D-22419 Hamburg, Germany
All rights reserved. Observe protection notice ISO 16016.

Nordex N131/3900 IEC S – Noise level measurement requirements

Basis: The specified sound power levels are expected values in terms of statistics. Results of single measurements will be within the confidence interval according to IEC 61400-14 [4].

Remarks:

Verification according to: Measurements are to be carried out by a measuring institute accredited for noise emission measurements at wind turbines according to ISO/IEC 17025 [3] at the reference position as defined in IEC 61400-11 [1]. The data analysis must be carried out according to the preferred method 1 of IEC 61400-11 [1]. The tonal penalties in the vicinity of wind turbines K_{TN} based on these measurements are to be determined according to „Technische Richtlinien für Windenergieanlagen“ [2].

Tonality: The noise can be tonal in the vicinity of wind turbines. The specified sound power level includes potential tonal penalties according to „Technische Richtlinien für Windenergieanlagen“ [2], without taking into account any tonality $K_{TN} \leq 2$ dB.

- [1] IEC 61400-11 ed. 2: Wind Turbine Generator Systems - Part 11: Acoustic Noise Measurement Techniques; 2002-12
- [2] Technische Richtlinie für Windenergieanlagen - Teil 1: Bestimmung der Schallemissionswerte, Revision 18; FGW 2008-02
- [3] ISO/IEC 17025: General requirements for the competence of testing and calibration laboratories; 2017-11
- [4] IEC 61400-14, Wind turbines - Part 14: Declaration of apparent sound power level and tonality values, first edition, 2005-03

Abbreviations:

L_{WA} ... A-weighted sound power level
 STE ... Serrated Trailing Edge

Nordex N131/3900 IEC S – Noise level, rated power and available hub heights

operating mode	rated power [kW]	maximum sound power level over the complete operating range of the wind turbine		available hub heights [m]			
		L _{WA} [dB(A)]	L _{WA} (STE) [dB(A)]	84	114	120	134
Mode 0	3900	107.7	106.2	●	●	●	●
Mode 1	3810	107.2	105.7	●	●	●	●
Mode 2	3710	106.7	105.2	●	●	●	●
Mode 3	3600	106.4	104.9	●	●	●	●
Mode 4	3500	106.0	104.5	●	●	●	●
Mode 5	3400	105.6	104.1	●	●	●	●
Mode 6	3130	103.0	101.5	●	●	–	●
Mode 7	3060	102.5	101.0	●	●	–	●
Mode 8	2920	102.0	100.5	●	●	●	●
Mode 9	2860	101.5	100.0	●	●	●	–
Mode 10	2800	101.0	99.5	●	●	●	–
Mode 11	2730	100.5	99.0	●	●	●	–
Mode 12	2670	100.0	98.5	●	●	●	–
Mode 13	2610	99.5	98.0	●	●	●	●

- mode available
- mode on request
- mode not available

Nordex N131/3900 IEC S – Verification conditions power curve

Basis: These power curve values are based on aerodynamic calculations by the Nordex Energy SE & Co. KG.

Determinations for the power curve verification:

Verification according to:	IEC 61400-12-1
Type of anemometer:	Thies First Class Advanced or Vector A100
Type of LiDAR:	Windcube V2 or ZX300
Measurement of power:	low voltage side
Air density:	normalization to the nearest air density shown in the table
Filter of turbulence intensity:	$9\% \leq TI \leq 20\%$
Filter of wind shear:	$0 \leq \alpha \leq 0.3$ Wind shear measurement and determination according to the requirements of MEASNET power performance measurement procedure, Version 5, December - 2009, chapter 3.3 and 3.8
Filter of inflow angle:	$-2^\circ \leq \psi \leq +2^\circ$
Filter of temperature:	$\vartheta \leq 25^\circ\text{C}$
Ice / snow on the blades:	No (determined with ice detectors)
Filter of grid reactive power:	Power factor = 1.0
Status signal:	Ready for unlimited operation in the corresponding operational mode without consideration of the cut-out hysteresis

Abbreviations:

TI ...	turbulence intensity
α ...	Hellmann exponent
ψ ...	vertical inflow angle
ϑ ...	air temperature
v_H ...	hub height wind speed

Nordex N131/3900 IEC S – Power curves – Mode 0

for hub heights 84 m, 114 m, 120 m and 134 m									
wind speed v_H [m/s]	Power P_{el} [kW] at air density ρ [kg/m ³]								
	0.900	0.925	0.950	0.975	1.000	1.025	1.050	1.075	1.100
3.0	1	3	4	5	7	8	9	10	12
3.5	52	55	58	61	63	66	69	71	74
4.0	122	127	132	136	141	146	150	155	159
4.5	210	218	225	232	239	246	253	260	267
5.0	317	327	337	347	357	367	377	387	397
5.5	442	456	469	483	496	510	523	537	550
6.0	589	607	624	642	659	677	694	712	729
6.5	760	783	805	827	849	871	893	915	937
7.0	958	986	1013	1041	1068	1096	1123	1151	1178
7.5	1186	1219	1253	1287	1320	1354	1387	1420	1454
8.0	1444	1485	1525	1565	1606	1646	1686	1727	1767
8.5	1731	1779	1827	1875	1922	1970	2018	2065	2113
9.0	2039	2095	2151	2207	2262	2317	2373	2428	2482
9.5	2363	2426	2490	2553	2616	2679	2741	2803	2866
10.0	2695	2766	2837	2907	2977	3046	3115	3174	3228
10.5	3030	3107	3183	3243	3302	3360	3418	3465	3506
11.0	3329	3392	3456	3503	3548	3593	3638	3673	3701
11.5	3556	3606	3656	3690	3722	3754	3786	3809	3826
12.0	3720	3756	3792	3813	3833	3853	3873	3883	3887
12.5	3827	3850	3873	3881	3887	3894	3900	3900	3900
13.0	3884	3893	3900	3900	3900	3900	3900	3900	3900
13.5	3900	3900	3900	3900	3900	3900	3900	3900	3900
14.0	3900	3900	3900	3900	3900	3900	3900	3900	3900
14.5	3900	3900	3900	3900	3900	3900	3900	3900	3900
15.0	3900	3900	3900	3900	3900	3900	3900	3900	3900
15.5	3900	3900	3900	3900	3900	3900	3900	3900	3900
16.0	3900	3900	3900	3900	3900	3900	3900	3900	3900
16.5	3900	3900	3900	3900	3900	3900	3900	3900	3900
17.0	3900	3900	3900	3900	3900	3900	3900	3900	3900
17.5	3900	3900	3900	3900	3900	3900	3900	3900	3900
18.0	3900	3900	3900	3900	3900	3900	3900	3900	3900
18.5	3900	3900	3900	3900	3900	3900	3900	3900	3900
19.0	3900	3900	3900	3900	3900	3900	3900	3900	3900
19.5	3900	3900	3900	3900	3900	3900	3900	3900	3900
20.0	3900	3900	3900	3900	3900	3900	3900	3900	3900
20.5*	3861	3861	3861	3861	3861	3861	3861	3861	3861
21.0*	3771	3771	3771	3771	3771	3771	3771	3771	3771
21.5*	3592	3592	3592	3592	3592	3592	3592	3592	3592
22.0*	3327	3327	3327	3327	3327	3327	3327	3327	3327
22.5*	3003	3003	3003	3003	3003	3003	3003	3003	3003
23.0*	2906	2906	2906	2906	2906	2906	2906	2906	2906
23.5*	2874	2874	2874	2874	2874	2874	2874	2874	2874
24.0*	2855	2855	2855	2855	2855	2855	2855	2855	2855
24.5*	2835	2835	2835	2835	2835	2835	2835	2835	2835
25.0*	2820	2820	2820	2820	2820	2820	2820	2820	2820

* These values are based on a yield and load optimized operation that is not feasible at all sites.

Nordex N131/3900 IEC S – Power curves – Mode 0

for hub heights 84 m, 114 m, 120 m and 134 m								
wind speed v_H [m/s]	Power P_{el} [kW] at air density ρ [kg/m ³]							
	1.125	1.150	1.175	1.200	1.225	1.250	1.275	1.300
3.0	13	14	15	17	18	19	21	22
3.5	77	79	82	85	87	90	93	95
4.0	164	169	173	178	182	187	192	196
4.5	274	281	288	295	302	309	316	323
5.0	407	417	427	437	447	457	467	477
5.5	564	577	590	604	617	631	644	657
6.0	746	764	781	799	816	833	851	868
6.5	959	981	1003	1025	1047	1069	1091	1113
7.0	1205	1233	1260	1287	1314	1342	1369	1396
7.5	1487	1520	1554	1587	1620	1653	1687	1720
8.0	1807	1847	1887	1927	1967	2007	2046	2086
8.5	2160	2208	2255	2302	2349	2396	2442	2489
9.0	2537	2591	2645	2700	2754	2809	2863	2917
9.5	2927	2989	3050	3105	3153	3201	3249	3297
10.0	3281	3333	3386	3431	3468	3504	3540	3576
10.5	3547	3587	3627	3661	3686	3712	3737	3761
11.0	3730	3758	3786	3808	3823	3837	3851	3864
11.5	3843	3859	3876	3886	3889	3892	3895	3897
12.0	3892	3896	3900	3900	3900	3900	3900	3900
12.5	3900	3900	3900	3900	3900	3900	3900	3900
13.0	3900	3900	3900	3900	3900	3900	3900	3900
13.5	3900	3900	3900	3900	3900	3900	3900	3900
14.0	3900	3900	3900	3900	3900	3900	3900	3900
14.5	3900	3900	3900	3900	3900	3900	3900	3900
15.0	3900	3900	3900	3900	3900	3900	3900	3900
15.5	3900	3900	3900	3900	3900	3900	3900	3900
16.0	3900	3900	3900	3900	3900	3900	3900	3900
16.5	3900	3900	3900	3900	3900	3900	3900	3900
17.0	3900	3900	3900	3900	3900	3900	3900	3900
17.5	3900	3900	3900	3900	3900	3900	3900	3900
18.0	3900	3900	3900	3900	3900	3900	3900	3900
18.5	3900	3900	3900	3900	3900	3900	3900	3900
19.0	3900	3900	3900	3900	3900	3900	3900	3900
19.5	3900	3900	3900	3900	3900	3900	3900	3900
20.0	3900	3900	3900	3900	3900	3900	3900	3900
20.5*	3861	3861	3861	3861	3861	3861	3861	3861
21.0*	3771	3771	3771	3771	3771	3771	3771	3771
21.5*	3592	3592	3592	3592	3592	3592	3592	3592
22.0*	3327	3327	3327	3327	3327	3327	3327	3327
22.5*	3003	3003	3003	3003	3003	3003	3003	3003
23.0*	2906	2906	2906	2906	2906	2906	2906	2906
23.5*	2874	2874	2874	2874	2874	2874	2874	2874
24.0*	2855	2855	2855	2855	2855	2855	2855	2855
24.5*	2835	2835	2835	2835	2835	2835	2835	2835
25.0*	2820	2820	2820	2820	2820	2820	2820	2820

* These values are based on a yield and load optimized operation that is not feasible at all sites.

Nordex N131/3900 IEC S – Power curves – Mode 1

for hub heights 84 m, 114 m, 120 m and 134 m									
wind speed v_H [m/s]	Power P_{el} [kW] at air density ρ [kg/m ³]								
	0.900	0.925	0.950	0.975	1.000	1.025	1.050	1.075	1.100
3.0	1	3	4	5	7	8	9	10	12
3.5	52	55	58	61	63	66	69	71	74
4.0	122	127	132	136	141	146	150	155	159
4.5	210	218	225	232	239	246	253	260	267
5.0	317	327	337	347	357	367	377	387	397
5.5	442	456	469	483	496	510	523	537	550
6.0	589	607	624	642	659	677	694	711	729
6.5	760	783	805	827	849	871	893	915	937
7.0	958	986	1013	1041	1068	1096	1123	1151	1178
7.5	1186	1219	1253	1287	1320	1353	1387	1420	1454
8.0	1444	1485	1525	1565	1606	1646	1686	1727	1767
8.5	1730	1778	1826	1874	1922	1969	2017	2064	2112
9.0	2037	2093	2148	2204	2259	2314	2369	2424	2479
9.5	2357	2421	2484	2547	2609	2672	2734	2797	2859
10.0	2685	2756	2826	2896	2966	3035	3096	3150	3203
10.5	3014	3091	3156	3215	3273	3331	3381	3422	3463
11.0	3296	3359	3411	3457	3502	3547	3584	3613	3642
11.5	3508	3558	3597	3629	3662	3694	3719	3736	3753
12.0	3658	3695	3720	3740	3760	3780	3792	3797	3802
12.5	3754	3777	3789	3796	3803	3809	3810	3810	3810
13.0	3800	3809	3810	3810	3810	3810	3810	3810	3810
13.5	3810	3810	3810	3810	3810	3810	3810	3810	3810
14.0	3810	3810	3810	3810	3810	3810	3810	3810	3810
14.5	3810	3810	3810	3810	3810	3810	3810	3810	3810
15.0	3810	3810	3810	3810	3810	3810	3810	3810	3810
15.5	3810	3810	3810	3810	3810	3810	3810	3810	3810
16.0	3810	3810	3810	3810	3810	3810	3810	3810	3810
16.5	3810	3810	3810	3810	3810	3810	3810	3810	3810
17.0	3810	3810	3810	3810	3810	3810	3810	3810	3810
17.5	3810	3810	3810	3810	3810	3810	3810	3810	3810
18.0	3810	3810	3810	3810	3810	3810	3810	3810	3810
18.5	3810	3810	3810	3810	3810	3810	3810	3810	3810
19.0	3810	3810	3810	3810	3810	3810	3810	3810	3810
19.5	3810	3810	3810	3810	3810	3810	3810	3810	3810
20.0	3810	3810	3810	3810	3810	3810	3810	3810	3810
20.5*	3810	3810	3810	3810	3810	3810	3810	3810	3810
21.0*	3743	3743	3743	3743	3743	3743	3743	3743	3743
21.5*	3592	3592	3592	3592	3592	3592	3592	3592	3592
22.0*	3327	3327	3327	3327	3327	3327	3327	3327	3327
22.5*	3003	3003	3003	3003	3003	3003	3003	3003	3003
23.0*	2906	2906	2906	2906	2906	2906	2906	2906	2906
23.5*	2874	2874	2874	2874	2874	2874	2874	2874	2874
24.0*	2855	2855	2855	2855	2855	2855	2855	2855	2855
24.5*	2835	2835	2835	2835	2835	2835	2835	2835	2835
25.0*	2820	2820	2820	2820	2820	2820	2820	2820	2820

* These values are based on a yield and load optimized operation that is not feasible at all sites.

Nordex N131/3900 IEC S – Power curves – Mode 1

for hub heights 84 m, 114 m, 120 m and 134 m								
wind speed v_H [m/s]	Power P_{el} [kW] at air density ρ [kg/m ³]							
	1.125	1.150	1.175	1.200	1.225	1.250	1.275	1.300
3.0	13	14	15	17	18	19	21	22
3.5	77	79	82	85	87	90	93	95
4.0	164	169	173	178	182	187	192	196
4.5	274	281	288	295	302	309	316	323
5.0	407	417	427	437	447	457	467	477
5.5	563	577	590	604	617	631	644	657
6.0	746	764	781	799	816	833	851	868
6.5	959	981	1003	1025	1047	1069	1091	1113
7.0	1205	1233	1260	1287	1314	1342	1369	1396
7.5	1487	1520	1554	1587	1620	1653	1686	1719
8.0	1807	1847	1887	1927	1967	2007	2047	2086
8.5	2159	2207	2254	2301	2347	2394	2441	2487
9.0	2533	2587	2641	2696	2751	2805	2859	2912
9.5	2920	2981	3036	3085	3133	3181	3228	3276
10.0	3256	3309	3353	3390	3427	3463	3499	3535
10.5	3503	3543	3577	3602	3628	3653	3678	3702
11.0	3671	3699	3721	3735	3749	3763	3777	3791
11.5	3770	3786	3796	3799	3802	3805	3808	3810
12.0	3806	3810	3810	3810	3810	3810	3810	3810
12.5	3810	3810	3810	3810	3810	3810	3810	3810
13.0	3810	3810	3810	3810	3810	3810	3810	3810
13.5	3810	3810	3810	3810	3810	3810	3810	3810
14.0	3810	3810	3810	3810	3810	3810	3810	3810
14.5	3810	3810	3810	3810	3810	3810	3810	3810
15.0	3810	3810	3810	3810	3810	3810	3810	3810
15.5	3810	3810	3810	3810	3810	3810	3810	3810
16.0	3810	3810	3810	3810	3810	3810	3810	3810
16.5	3810	3810	3810	3810	3810	3810	3810	3810
17.0	3810	3810	3810	3810	3810	3810	3810	3810
17.5	3810	3810	3810	3810	3810	3810	3810	3810
18.0	3810	3810	3810	3810	3810	3810	3810	3810
18.5	3810	3810	3810	3810	3810	3810	3810	3810
19.0	3810	3810	3810	3810	3810	3810	3810	3810
19.5	3810	3810	3810	3810	3810	3810	3810	3810
20.0	3810	3810	3810	3810	3810	3810	3810	3810
20.5*	3810	3810	3810	3810	3810	3810	3810	3810
21.0*	3743	3743	3743	3743	3743	3743	3743	3743
21.5*	3592	3592	3592	3592	3592	3592	3592	3592
22.0*	3327	3327	3327	3327	3327	3327	3327	3327
22.5*	3003	3003	3003	3003	3003	3003	3003	3003
23.0*	2906	2906	2906	2906	2906	2906	2906	2906
23.5*	2874	2874	2874	2874	2874	2874	2874	2874
24.0*	2855	2855	2855	2855	2855	2855	2855	2855
24.5*	2835	2835	2835	2835	2835	2835	2835	2835
25.0*	2820	2820	2820	2820	2820	2820	2820	2820

* These values are based on a yield and load optimized operation that is not feasible at all sites.

Nordex N131/3900 IEC S – Power curves – Mode 2

for hub heights 84 m, 114 m, 120 m and 134 m									
wind speed v_H [m/s]	Power P_{el} [kW] at air density ρ [kg/m ³]								
	0.900	0.925	0.950	0.975	1.000	1.025	1.050	1.075	1.100
3.0	1	3	4	5	7	8	9	10	12
3.5	52	55	58	61	63	66	69	71	74
4.0	122	127	132	136	141	146	150	155	159
4.5	210	218	225	232	239	246	253	260	267
5.0	317	327	337	347	357	367	377	387	397
5.5	442	456	469	483	496	510	523	537	550
6.0	589	607	624	642	659	677	694	711	729
6.5	760	782	805	827	849	871	893	915	937
7.0	958	986	1013	1041	1068	1096	1123	1150	1178
7.5	1186	1219	1253	1286	1320	1353	1387	1420	1454
8.0	1444	1484	1525	1565	1606	1646	1686	1726	1766
8.5	1729	1777	1825	1872	1920	1968	2015	2063	2110
9.0	2034	2089	2145	2200	2256	2311	2365	2420	2475
9.5	2351	2415	2478	2541	2604	2666	2729	2791	2853
10.0	2677	2747	2818	2888	2957	3018	3072	3126	3179
10.5	3001	3069	3128	3187	3246	3294	3336	3377	3418
11.0	3264	3318	3364	3410	3456	3492	3521	3550	3579
11.5	3459	3500	3533	3566	3598	3622	3640	3657	3674
12.0	3594	3621	3642	3662	3682	3693	3698	3703	3707
12.5	3675	3690	3696	3703	3710	3710	3710	3710	3710
13.0	3708	3710	3710	3710	3710	3710	3710	3710	3710
13.5	3710	3710	3710	3710	3710	3710	3710	3710	3710
14.0	3710	3710	3710	3710	3710	3710	3710	3710	3710
14.5	3710	3710	3710	3710	3710	3710	3710	3710	3710
15.0	3710	3710	3710	3710	3710	3710	3710	3710	3710
15.5	3710	3710	3710	3710	3710	3710	3710	3710	3710
16.0	3710	3710	3710	3710	3710	3710	3710	3710	3710
16.5	3710	3710	3710	3710	3710	3710	3710	3710	3710
17.0	3710	3710	3710	3710	3710	3710	3710	3710	3710
17.5	3710	3710	3710	3710	3710	3710	3710	3710	3710
18.0	3710	3710	3710	3710	3710	3710	3710	3710	3710
18.5	3710	3710	3710	3710	3710	3710	3710	3710	3710
19.0	3710	3710	3710	3710	3710	3710	3710	3710	3710
19.5	3710	3710	3710	3710	3710	3710	3710	3710	3710
20.0	3710	3710	3710	3710	3710	3710	3710	3710	3710
20.5*	3710	3710	3710	3710	3710	3710	3710	3710	3710
21.0*	3689	3689	3689	3689	3689	3689	3689	3689	3689
21.5*	3537	3537	3537	3537	3537	3537	3537	3537	3537
22.0*	3327	3327	3327	3327	3327	3327	3327	3327	3327
22.5*	3003	3003	3003	3003	3003	3003	3003	3003	3003
23.0*	2906	2906	2906	2906	2906	2906	2906	2906	2906
23.5*	2874	2874	2874	2874	2874	2874	2874	2874	2874
24.0*	2855	2855	2855	2855	2855	2855	2855	2855	2855
24.5*	2835	2835	2835	2835	2835	2835	2835	2835	2835
25.0*	2820	2820	2820	2820	2820	2820	2820	2820	2820

* These values are based on a yield and load optimized operation that is not feasible at all sites.

Nordex N131/3900 IEC S – Power curves – Mode 2

for hub heights 84 m, 114 m, 120 m and 134 m								
wind speed v_H [m/s]	Power P_{el} [kW] at air density ρ [kg/m ³]							
	1.125	1.150	1.175	1.200	1.225	1.250	1.275	1.300
3.0	13	14	15	17	18	19	21	22
3.5	77	79	82	85	87	90	93	95
4.0	164	169	173	178	182	187	192	196
4.5	274	281	288	295	302	309	316	323
5.0	407	417	427	437	447	457	467	477
5.5	563	577	590	604	617	631	644	657
6.0	746	764	781	799	816	833	851	868
6.5	959	981	1003	1025	1047	1069	1091	1113
7.0	1205	1232	1260	1287	1314	1341	1369	1396
7.5	1487	1520	1554	1587	1620	1653	1686	1719
8.0	1806	1846	1886	1926	1966	2006	2046	2086
8.5	2158	2205	2252	2298	2345	2392	2438	2485
9.0	2529	2584	2639	2693	2748	2802	2856	2901
9.5	2915	2967	3016	3064	3112	3160	3208	3242
10.0	3232	3273	3310	3347	3383	3420	3456	3480
10.5	3459	3488	3514	3539	3565	3590	3616	3629
11.0	3608	3626	3641	3655	3670	3684	3698	3701
11.5	3691	3697	3700	3703	3706	3709	3710	3710
12.0	3710	3710	3710	3710	3710	3710	3710	3710
12.5	3710	3710	3710	3710	3710	3710	3710	3710
13.0	3710	3710	3710	3710	3710	3710	3710	3710
13.5	3710	3710	3710	3710	3710	3710	3710	3710
14.0	3710	3710	3710	3710	3710	3710	3710	3710
14.5	3710	3710	3710	3710	3710	3710	3710	3710
15.0	3710	3710	3710	3710	3710	3710	3710	3710
15.5	3710	3710	3710	3710	3710	3710	3710	3710
16.0	3710	3710	3710	3710	3710	3710	3710	3710
16.5	3710	3710	3710	3710	3710	3710	3710	3710
17.0	3710	3710	3710	3710	3710	3710	3710	3710
17.5	3710	3710	3710	3710	3710	3710	3710	3710
18.0	3710	3710	3710	3710	3710	3710	3710	3710
18.5	3710	3710	3710	3710	3710	3710	3710	3710
19.0	3710	3710	3710	3710	3710	3710	3710	3710
19.5	3710	3710	3710	3710	3710	3710	3710	3710
20.0	3710	3710	3710	3710	3710	3710	3710	3710
20.5*	3710	3710	3710	3710	3710	3710	3710	3710
21.0*	3689	3689	3689	3689	3689	3689	3689	3689
21.5*	3537	3537	3537	3537	3537	3537	3537	3537
22.0*	3327	3327	3327	3327	3327	3327	3327	3327
22.5*	3003	3003	3003	3003	3003	3003	3003	3003
23.0*	2906	2906	2906	2906	2906	2906	2906	2906
23.5*	2874	2874	2874	2874	2874	2874	2874	2874
24.0*	2855	2855	2855	2855	2855	2855	2855	2855
24.5*	2835	2835	2835	2835	2835	2835	2835	2835
25.0*	2820	2820	2820	2820	2820	2820	2820	2820

* These values are based on a yield and load optimized operation that is not feasible at all sites.

Nordex N131/3900 IEC S – Power curves – Mode 3

for hub heights 84 m, 114 m, 120 m and 134 m									
wind speed v_H [m/s]	Power P_{el} [kW] at air density ρ [kg/m ³]								
	0.900	0.925	0.950	0.975	1.000	1.025	1.050	1.075	1.100
3.0	1	3	4	5	7	8	9	10	12
3.5	52	55	58	61	63	66	69	71	74
4.0	122	127	132	136	141	146	150	155	159
4.5	210	218	225	232	239	246	253	260	267
5.0	317	327	337	347	357	367	377	387	397
5.5	442	456	469	483	496	510	523	537	550
6.0	589	607	624	642	659	676	694	711	729
6.5	760	782	805	827	849	871	893	915	937
7.0	958	986	1013	1041	1068	1096	1123	1150	1178
7.5	1186	1219	1253	1286	1320	1353	1387	1420	1454
8.0	1444	1484	1525	1565	1606	1646	1686	1726	1766
8.5	1730	1778	1825	1873	1921	1969	2016	2064	2111
9.0	2035	2091	2146	2202	2257	2312	2367	2421	2476
9.5	2353	2417	2480	2543	2606	2669	2731	2794	2852
10.0	2678	2749	2819	2889	2945	2999	3053	3107	3156
10.5	2988	3047	3107	3166	3210	3251	3293	3334	3371
11.0	3228	3274	3320	3366	3398	3427	3457	3486	3511
11.5	3402	3435	3468	3501	3520	3538	3556	3573	3586
12.0	3517	3538	3558	3579	3585	3590	3595	3599	3600
12.5	3581	3588	3595	3600	3600	3600	3600	3600	3600
13.0	3600	3600	3600	3600	3600	3600	3600	3600	3600
13.5	3600	3600	3600	3600	3600	3600	3600	3600	3600
14.0	3600	3600	3600	3600	3600	3600	3600	3600	3600
14.5	3600	3600	3600	3600	3600	3600	3600	3600	3600
15.0	3600	3600	3600	3600	3600	3600	3600	3600	3600
15.5	3600	3600	3600	3600	3600	3600	3600	3600	3600
16.0	3600	3600	3600	3600	3600	3600	3600	3600	3600
16.5	3600	3600	3600	3600	3600	3600	3600	3600	3600
17.0	3600	3600	3600	3600	3600	3600	3600	3600	3600
17.5	3600	3600	3600	3600	3600	3600	3600	3600	3600
18.0	3600	3600	3600	3600	3600	3600	3600	3600	3600
18.5	3600	3600	3600	3600	3600	3600	3600	3600	3600
19.0	3600	3600	3600	3600	3600	3600	3600	3600	3600
19.5	3600	3600	3600	3600	3600	3600	3600	3600	3600
20.0	3600	3600	3600	3600	3600	3600	3600	3600	3600
20.5*	3600	3600	3600	3600	3600	3600	3600	3600	3600
21.0*	3600	3600	3600	3600	3600	3600	3600	3600	3600
21.5*	3500	3500	3500	3500	3500	3500	3500	3500	3500
22.0*	3327	3327	3327	3327	3327	3327	3327	3327	3327
22.5*	3003	3003	3003	3003	3003	3003	3003	3003	3003
23.0*	2906	2906	2906	2906	2906	2906	2906	2906	2906
23.5*	2874	2874	2874	2874	2874	2874	2874	2874	2874
24.0*	2855	2855	2855	2855	2855	2855	2855	2855	2855
24.5*	2835	2835	2835	2835	2835	2835	2835	2835	2835
25.0*	2820	2820	2820	2820	2820	2820	2820	2820	2820

* These values are based on a yield and load optimized operation that is not feasible at all sites.

Nordex N131/3900 IEC S – Power curves – Mode 3

for hub heights 84 m, 114 m, 120 m and 134 m								
wind speed v_H [m/s]	Power P_{el} [kW] at air density ρ [kg/m ³]							
	1.125	1.150	1.175	1.200	1.225	1.250	1.275	1.300
3.0	13	14	15	17	18	19	21	22
3.5	77	79	82	85	87	90	93	95
4.0	164	169	173	178	182	187	192	196
4.5	274	281	288	295	302	309	316	323
5.0	407	417	427	437	447	457	467	477
5.5	563	577	590	604	617	630	644	657
6.0	746	764	781	798	816	833	851	868
6.5	959	981	1003	1025	1047	1069	1091	1113
7.0	1205	1232	1260	1287	1314	1341	1369	1396
7.5	1487	1520	1553	1587	1620	1653	1686	1719
8.0	1806	1847	1887	1927	1967	2006	2046	2085
8.5	2158	2205	2252	2299	2345	2393	2440	2487
9.0	2531	2586	2641	2696	2750	2798	2842	2886
9.5	2901	2950	2999	3047	3096	3134	3167	3200
10.0	3193	3231	3268	3304	3341	3369	3392	3415
10.5	3397	3423	3449	3475	3500	3518	3530	3542
11.0	3526	3541	3555	3570	3584	3591	3593	3594
11.5	3589	3592	3595	3598	3600	3600	3600	3600
12.0	3600	3600	3600	3600	3600	3600	3600	3600
12.5	3600	3600	3600	3600	3600	3600	3600	3600
13.0	3600	3600	3600	3600	3600	3600	3600	3600
13.5	3600	3600	3600	3600	3600	3600	3600	3600
14.0	3600	3600	3600	3600	3600	3600	3600	3600
14.5	3600	3600	3600	3600	3600	3600	3600	3600
15.0	3600	3600	3600	3600	3600	3600	3600	3600
15.5	3600	3600	3600	3600	3600	3600	3600	3600
16.0	3600	3600	3600	3600	3600	3600	3600	3600
16.5	3600	3600	3600	3600	3600	3600	3600	3600
17.0	3600	3600	3600	3600	3600	3600	3600	3600
17.5	3600	3600	3600	3600	3600	3600	3600	3600
18.0	3600	3600	3600	3600	3600	3600	3600	3600
18.5	3600	3600	3600	3600	3600	3600	3600	3600
19.0	3600	3600	3600	3600	3600	3600	3600	3600
19.5	3600	3600	3600	3600	3600	3600	3600	3600
20.0	3600	3600	3600	3600	3600	3600	3600	3600
20.5*	3600	3600	3600	3600	3600	3600	3600	3600
21.0*	3600	3600	3600	3600	3600	3600	3600	3600
21.5*	3500	3500	3500	3500	3500	3500	3500	3500
22.0*	3327	3327	3327	3327	3327	3327	3327	3327
22.5*	3003	3003	3003	3003	3003	3003	3003	3003
23.0*	2906	2906	2906	2906	2906	2906	2906	2906
23.5*	2874	2874	2874	2874	2874	2874	2874	2874
24.0*	2855	2855	2855	2855	2855	2855	2855	2855
24.5*	2835	2835	2835	2835	2835	2835	2835	2835
25.0*	2820	2820	2820	2820	2820	2820	2820	2820

* These values are based on a yield and load optimized operation that is not feasible at all sites.

Nordex N131/3900 IEC S – Power curves – Mode 4

for hub heights 84 m, 114 m, 120 m and 134 m									
wind speed v_H [m/s]	Power P_{el} [kW] at air density ρ [kg/m ³]								
	0.900	0.925	0.950	0.975	1.000	1.025	1.050	1.075	1.100
3.0	1	3	4	5	7	8	9	10	12
3.5	52	55	58	61	63	66	69	71	74
4.0	122	127	132	136	141	146	150	155	159
4.5	210	218	225	232	239	246	253	260	267
5.0	317	327	337	347	357	367	377	387	397
5.5	442	456	469	483	496	510	523	537	550
6.0	589	607	624	642	659	676	694	711	729
6.5	760	782	804	827	849	871	893	915	937
7.0	958	986	1013	1041	1068	1095	1123	1150	1178
7.5	1186	1219	1253	1286	1320	1353	1387	1420	1453
8.0	1444	1484	1525	1565	1605	1645	1686	1726	1766
8.5	1728	1775	1823	1871	1919	1966	2014	2061	2108
9.0	2030	2086	2141	2196	2251	2306	2361	2416	2471
9.5	2344	2407	2470	2534	2597	2659	2722	2780	2829
10.0	2663	2733	2804	2862	2917	2971	3025	3073	3110
10.5	2954	3013	3073	3119	3161	3203	3244	3280	3306
11.0	3176	3222	3268	3302	3332	3362	3391	3415	3430
11.5	3334	3367	3400	3422	3440	3457	3475	3487	3490
12.0	3436	3456	3477	3485	3490	3495	3500	3500	3500
12.5	3487	3494	3500	3500	3500	3500	3500	3500	3500
13.0	3500	3500	3500	3500	3500	3500	3500	3500	3500
13.5	3500	3500	3500	3500	3500	3500	3500	3500	3500
14.0	3500	3500	3500	3500	3500	3500	3500	3500	3500
14.5	3500	3500	3500	3500	3500	3500	3500	3500	3500
15.0	3500	3500	3500	3500	3500	3500	3500	3500	3500
15.5	3500	3500	3500	3500	3500	3500	3500	3500	3500
16.0	3500	3500	3500	3500	3500	3500	3500	3500	3500
16.5	3500	3500	3500	3500	3500	3500	3500	3500	3500
17.0	3500	3500	3500	3500	3500	3500	3500	3500	3500
17.5	3500	3500	3500	3500	3500	3500	3500	3500	3500
18.0	3500	3500	3500	3500	3500	3500	3500	3500	3500
18.5	3500	3500	3500	3500	3500	3500	3500	3500	3500
19.0	3500	3500	3500	3500	3500	3500	3500	3500	3500
19.5	3500	3500	3500	3500	3500	3500	3500	3500	3500
20.0	3500	3500	3500	3500	3500	3500	3500	3500	3500
20.5*	3500	3500	3500	3500	3500	3500	3500	3500	3500
21.0*	3500	3500	3500	3500	3500	3500	3500	3500	3500
21.5*	3436	3436	3436	3436	3436	3436	3436	3436	3436
22.0*	3275	3275	3275	3275	3275	3275	3275	3275	3275
22.5*	3003	3003	3003	3003	3003	3003	3003	3003	3003
23.0*	2906	2906	2906	2906	2906	2906	2906	2906	2906
23.5*	2874	2874	2874	2874	2874	2874	2874	2874	2874
24.0*	2855	2855	2855	2855	2855	2855	2855	2855	2855
24.5*	2835	2835	2835	2835	2835	2835	2835	2835	2835
25.0*	2820	2820	2820	2820	2820	2820	2820	2820	2820

* These values are based on a yield and load optimized operation that is not feasible at all sites.

Nordex N131/3900 IEC S – Power curves – Mode 4

for hub heights 84 m, 114 m, 120 m and 134 m								
wind speed v_H [m/s]	Power P_{el} [kW] at air density ρ [kg/m ³]							
	1.125	1.150	1.175	1.200	1.225	1.250	1.275	1.300
3.0	13	14	15	17	18	19	21	22
3.5	77	79	82	85	87	90	93	95
4.0	164	169	173	178	182	187	192	196
4.5	274	281	288	295	302	309	316	323
5.0	407	417	427	437	447	457	467	477
5.5	563	577	590	604	617	630	644	657
6.0	746	764	781	798	816	833	850	868
6.5	959	981	1003	1025	1047	1069	1091	1113
7.0	1205	1232	1260	1287	1314	1341	1368	1396
7.5	1487	1520	1553	1587	1620	1653	1686	1719
8.0	1806	1846	1886	1926	1966	2005	2045	2084
8.5	2155	2202	2249	2296	2343	2391	2438	2486
9.0	2526	2581	2636	2691	2736	2780	2824	2868
9.5	2878	2927	2976	3024	3058	3091	3124	3157
10.0	3148	3185	3222	3259	3282	3305	3328	3351
10.5	3333	3359	3385	3410	3423	3436	3448	3460
11.0	3445	3460	3474	3489	3492	3493	3495	3497
11.5	3493	3496	3499	3500	3500	3500	3500	3500
12.0	3500	3500	3500	3500	3500	3500	3500	3500
12.5	3500	3500	3500	3500	3500	3500	3500	3500
13.0	3500	3500	3500	3500	3500	3500	3500	3500
13.5	3500	3500	3500	3500	3500	3500	3500	3500
14.0	3500	3500	3500	3500	3500	3500	3500	3500
14.5	3500	3500	3500	3500	3500	3500	3500	3500
15.0	3500	3500	3500	3500	3500	3500	3500	3500
15.5	3500	3500	3500	3500	3500	3500	3500	3500
16.0	3500	3500	3500	3500	3500	3500	3500	3500
16.5	3500	3500	3500	3500	3500	3500	3500	3500
17.0	3500	3500	3500	3500	3500	3500	3500	3500
17.5	3500	3500	3500	3500	3500	3500	3500	3500
18.0	3500	3500	3500	3500	3500	3500	3500	3500
18.5	3500	3500	3500	3500	3500	3500	3500	3500
19.0	3500	3500	3500	3500	3500	3500	3500	3500
19.5	3500	3500	3500	3500	3500	3500	3500	3500
20.0	3500	3500	3500	3500	3500	3500	3500	3500
20.5*	3500	3500	3500	3500	3500	3500	3500	3500
21.0*	3500	3500	3500	3500	3500	3500	3500	3500
21.5*	3436	3436	3436	3436	3436	3436	3436	3436
22.0*	3275	3275	3275	3275	3275	3275	3275	3275
22.5*	3003	3003	3003	3003	3003	3003	3003	3003
23.0*	2906	2906	2906	2906	2906	2906	2906	2906
23.5*	2874	2874	2874	2874	2874	2874	2874	2874
24.0*	2855	2855	2855	2855	2855	2855	2855	2855
24.5*	2835	2835	2835	2835	2835	2835	2835	2835
25.0*	2820	2820	2820	2820	2820	2820	2820	2820

* These values are based on a yield and load optimized operation that is not feasible at all sites.

Nordex N131/3900 IEC S – Power curves – Mode 5

for hub heights 84 m, 114 m, 120 m and 134 m									
wind speed v_H [m/s]	Power P_{el} [kW] at air density ρ [kg/m ³]								
	0.900	0.925	0.950	0.975	1.000	1.025	1.050	1.075	1.100
3.0	1	3	4	5	7	8	9	10	12
3.5	52	55	58	61	63	66	69	71	74
4.0	122	127	132	136	141	146	150	155	159
4.5	210	217	225	232	239	246	253	260	267
5.0	317	327	337	347	357	367	377	387	397
5.5	442	456	469	483	496	510	523	536	550
6.0	589	607	624	641	659	676	694	711	729
6.5	760	782	804	827	849	871	893	915	937
7.0	958	986	1013	1041	1068	1095	1123	1150	1177
7.5	1186	1219	1253	1286	1320	1353	1387	1420	1453
8.0	1444	1484	1524	1565	1605	1645	1686	1726	1766
8.5	1726	1774	1822	1870	1918	1965	2013	2060	2107
9.0	2027	2083	2138	2193	2248	2303	2359	2414	2470
9.5	2338	2402	2465	2528	2592	2655	2711	2760	2810
10.0	2653	2724	2783	2838	2893	2948	2993	3030	3068
10.5	2924	2984	3032	3074	3116	3158	3192	3218	3245
11.0	3127	3174	3209	3239	3269	3299	3321	3336	3351
11.5	3268	3302	3324	3342	3360	3378	3388	3391	3394
12.0	3355	3376	3386	3391	3396	3400	3400	3400	3400
12.5	3393	3400	3400	3400	3400	3400	3400	3400	3400
13.0	3400	3400	3400	3400	3400	3400	3400	3400	3400
13.5	3400	3400	3400	3400	3400	3400	3400	3400	3400
14.0	3400	3400	3400	3400	3400	3400	3400	3400	3400
14.5	3400	3400	3400	3400	3400	3400	3400	3400	3400
15.0	3400	3400	3400	3400	3400	3400	3400	3400	3400
15.5	3400	3400	3400	3400	3400	3400	3400	3400	3400
16.0	3400	3400	3400	3400	3400	3400	3400	3400	3400
16.5	3400	3400	3400	3400	3400	3400	3400	3400	3400
17.0	3400	3400	3400	3400	3400	3400	3400	3400	3400
17.5	3400	3400	3400	3400	3400	3400	3400	3400	3400
18.0	3400	3400	3400	3400	3400	3400	3400	3400	3400
18.5	3400	3400	3400	3400	3400	3400	3400	3400	3400
19.0	3400	3400	3400	3400	3400	3400	3400	3400	3400
19.5	3400	3400	3400	3400	3400	3400	3400	3400	3400
20.0	3400	3400	3400	3400	3400	3400	3400	3400	3400
20.5*	3400	3400	3400	3400	3400	3400	3400	3400	3400
21.0*	3400	3400	3400	3400	3400	3400	3400	3400	3400
21.5*	3369	3369	3369	3369	3369	3369	3369	3369	3369
22.0*	3242	3242	3242	3242	3242	3242	3242	3242	3242
22.5*	3003	3003	3003	3003	3003	3003	3003	3003	3003
23.0*	2906	2906	2906	2906	2906	2906	2906	2906	2906
23.5*	2874	2874	2874	2874	2874	2874	2874	2874	2874
24.0*	2855	2855	2855	2855	2855	2855	2855	2855	2855
24.5*	2835	2835	2835	2835	2835	2835	2835	2835	2835
25.0*	2820	2820	2820	2820	2820	2820	2820	2820	2820

* These values are based on a yield and load optimized operation that is not feasible at all sites.

Nordex N131/3900 IEC S – Power curves – Mode 5

for hub heights 84 m, 114 m, 120 m and 134 m								
wind speed v_H [m/s]	Power P_{el} [kW] at air density ρ [kg/m ³]							
	1.125	1.150	1.175	1.200	1.225	1.250	1.275	1.300
3.0	13	14	15	17	18	19	21	22
3.5	77	79	82	85	87	90	93	95
4.0	164	169	173	178	182	187	192	196
4.5	274	281	288	295	302	309	316	323
5.0	407	417	427	437	447	457	467	477
5.5	563	577	590	604	617	630	644	657
6.0	746	764	781	798	816	833	850	868
6.5	959	981	1003	1025	1047	1069	1091	1113
7.0	1205	1232	1259	1287	1314	1341	1368	1395
7.5	1487	1520	1553	1587	1620	1653	1686	1719
8.0	1806	1846	1886	1926	1965	2005	2044	2084
8.5	2154	2201	2248	2296	2343	2391	2439	2486
9.0	2525	2581	2631	2676	2720	2764	2808	2853
9.5	2859	2909	2951	2985	3018	3051	3084	3117
10.0	3106	3143	3175	3198	3221	3244	3267	3290
10.5	3271	3298	3318	3331	3343	3355	3368	3380
11.0	3366	3381	3391	3393	3394	3396	3398	3400
11.5	3397	3400	3400	3400	3400	3400	3400	3400
12.0	3400	3400	3400	3400	3400	3400	3400	3400
12.5	3400	3400	3400	3400	3400	3400	3400	3400
13.0	3400	3400	3400	3400	3400	3400	3400	3400
13.5	3400	3400	3400	3400	3400	3400	3400	3400
14.0	3400	3400	3400	3400	3400	3400	3400	3400
14.5	3400	3400	3400	3400	3400	3400	3400	3400
15.0	3400	3400	3400	3400	3400	3400	3400	3400
15.5	3400	3400	3400	3400	3400	3400	3400	3400
16.0	3400	3400	3400	3400	3400	3400	3400	3400
16.5	3400	3400	3400	3400	3400	3400	3400	3400
17.0	3400	3400	3400	3400	3400	3400	3400	3400
17.5	3400	3400	3400	3400	3400	3400	3400	3400
18.0	3400	3400	3400	3400	3400	3400	3400	3400
18.5	3400	3400	3400	3400	3400	3400	3400	3400
19.0	3400	3400	3400	3400	3400	3400	3400	3400
19.5	3400	3400	3400	3400	3400	3400	3400	3400
20.0	3400	3400	3400	3400	3400	3400	3400	3400
20.5*	3400	3400	3400	3400	3400	3400	3400	3400
21.0*	3400	3400	3400	3400	3400	3400	3400	3400
21.5*	3369	3369	3369	3369	3369	3369	3369	3369
22.0*	3242	3242	3242	3242	3242	3242	3242	3242
22.5*	3003	3003	3003	3003	3003	3003	3003	3003
23.0*	2906	2906	2906	2906	2906	2906	2906	2906
23.5*	2874	2874	2874	2874	2874	2874	2874	2874
24.0*	2855	2855	2855	2855	2855	2855	2855	2855
24.5*	2835	2835	2835	2835	2835	2835	2835	2835
25.0*	2820	2820	2820	2820	2820	2820	2820	2820

* These values are based on a yield and load optimized operation that is not feasible at all sites.

Nordex N131/3900 IEC S – Power curves – Mode 6

for hub heights 84 m, 114 m and 134 m (mode not available for 120 m)									
wind speed v_H [m/s]	Power P_{el} [kW] at air density ρ [kg/m ³]								
	0.900	0.925	0.950	0.975	1.000	1.025	1.050	1.075	1.100
3.0	1	3	4	5	7	8	9	10	12
3.5	52	55	58	60	63	66	69	71	74
4.0	122	127	132	136	141	146	150	155	159
4.5	210	217	225	232	239	246	253	260	267
5.0	317	327	337	347	357	367	377	387	397
5.5	442	456	469	483	496	510	523	536	550
6.0	589	606	624	641	659	676	694	711	728
6.5	760	782	804	826	849	871	893	915	937
7.0	959	986	1014	1041	1069	1096	1124	1151	1178
7.5	1180	1214	1247	1281	1314	1348	1382	1415	1449
8.0	1414	1455	1495	1536	1576	1617	1657	1698	1739
8.5	1654	1701	1750	1798	1845	1893	1942	1990	2038
9.0	1895	1949	2006	2061	2116	2171	2227	2284	2341
9.5	2134	2195	2260	2322	2385	2449	2513	2573	2624
10.0	2370	2439	2511	2581	2642	2697	2753	2802	2841
10.5	2602	2671	2733	2791	2840	2882	2926	2963	2990
11.0	2794	2851	2898	2944	2980	3011	3041	3066	3082
11.5	2936	2980	3014	3047	3071	3089	3108	3120	3124
12.0	3035	3066	3088	3108	3119	3124	3129	3130	3130
12.5	3097	3115	3122	3129	3130	3130	3130	3130	3130
13.0	3125	3130	3130	3130	3130	3130	3130	3130	3130
13.5	3130	3130	3130	3130	3130	3130	3130	3130	3130
14.0	3130	3130	3130	3130	3130	3130	3130	3130	3130
14.5	3130	3130	3130	3130	3130	3130	3130	3130	3130
15.0	3130	3130	3130	3130	3130	3130	3130	3130	3130
15.5	3130	3130	3130	3130	3130	3130	3130	3130	3130
16.0	3130	3130	3130	3130	3130	3130	3130	3130	3130
16.5	3130	3130	3130	3130	3130	3130	3130	3130	3130
17.0	3130	3130	3130	3130	3130	3130	3130	3130	3130
17.5	3130	3130	3130	3130	3130	3130	3130	3130	3130
18.0	3130	3130	3130	3130	3130	3130	3130	3130	3130
18.5	3130	3130	3130	3130	3130	3130	3130	3130	3130
19.0	3130	3130	3130	3130	3130	3130	3130	3130	3130
19.5	3130	3130	3130	3130	3130	3130	3130	3130	3130
20.0	3130	3130	3130	3130	3130	3130	3130	3130	3130
20.5*	3130	3130	3130	3130	3130	3130	3130	3130	3130
21.0*	3130	3130	3130	3130	3130	3130	3130	3130	3130
21.5*	3130	3130	3130	3130	3130	3130	3130	3130	3130
22.0*	3086	3086	3086	3086	3086	3086	3086	3086	3086
22.5*	3003	3003	3003	3003	3003	3003	3003	3003	3003
23.0*	2906	2906	2906	2906	2906	2906	2906	2906	2906
23.5*	2874	2874	2874	2874	2874	2874	2874	2874	2874
24.0*	2855	2855	2855	2855	2855	2855	2855	2855	2855
24.5*	2835	2835	2835	2835	2835	2835	2835	2835	2835
25.0*	2820	2820	2820	2820	2820	2820	2820	2820	2820

* These values are based on a yield and load optimized operation that is not feasible at all sites.

Nordex N131/3900 IEC S – Power curves – Mode 6

for hub heights 84 m, 114 m and 134 m (mode not available for 120 m)								
wind speed v_H [m/s]	Power P_{el} [kW] at air density ρ [kg/m ³]							
	1.125	1.150	1.175	1.200	1.225	1.250	1.275	1.300
3.0	13	14	15	17	18	19	21	22
3.5	77	79	82	85	87	90	93	95
4.0	164	169	173	178	182	187	192	196
4.5	274	281	288	295	302	309	316	323
5.0	407	417	427	437	447	457	467	476
5.5	563	577	590	603	617	630	644	657
6.0	746	763	781	798	815	833	850	868
6.5	959	981	1003	1025	1047	1069	1091	1113
7.0	1206	1233	1260	1288	1315	1342	1369	1396
7.5	1482	1516	1549	1583	1616	1649	1682	1715
8.0	1780	1820	1861	1900	1940	1979	2018	2058
8.5	2087	2134	2183	2231	2280	2326	2373	2418
9.0	2399	2454	2508	2553	2598	2641	2683	2724
9.5	2676	2726	2770	2804	2838	2870	2902	2931
10.0	2881	2919	2952	2975	2999	3021	3043	3063
10.5	3018	3045	3066	3079	3092	3104	3115	3125
11.0	3098	3113	3123	3125	3127	3128	3130	3130
11.5	3127	3130	3130	3130	3130	3130	3130	3130
12.0	3130	3130	3130	3130	3130	3130	3130	3130
12.5	3130	3130	3130	3130	3130	3130	3130	3130
13.0	3130	3130	3130	3130	3130	3130	3130	3130
13.5	3130	3130	3130	3130	3130	3130	3130	3130
14.0	3130	3130	3130	3130	3130	3130	3130	3130
14.5	3130	3130	3130	3130	3130	3130	3130	3130
15.0	3130	3130	3130	3130	3130	3130	3130	3130
15.5	3130	3130	3130	3130	3130	3130	3130	3130
16.0	3130	3130	3130	3130	3130	3130	3130	3130
16.5	3130	3130	3130	3130	3130	3130	3130	3130
17.0	3130	3130	3130	3130	3130	3130	3130	3130
17.5	3130	3130	3130	3130	3130	3130	3130	3130
18.0	3130	3130	3130	3130	3130	3130	3130	3130
18.5	3130	3130	3130	3130	3130	3130	3130	3130
19.0	3130	3130	3130	3130	3130	3130	3130	3130
19.5	3130	3130	3130	3130	3130	3130	3130	3130
20.0	3130	3130	3130	3130	3130	3130	3130	3130
20.5*	3130	3130	3130	3130	3130	3130	3130	3130
21.0*	3130	3130	3130	3130	3130	3130	3130	3130
21.5*	3130	3130	3130	3130	3130	3130	3130	3130
22.0*	3086	3086	3086	3086	3086	3086	3086	3086
22.5*	3003	3003	3003	3003	3003	3003	3003	3003
23.0*	2906	2906	2906	2906	2906	2906	2906	2906
23.5*	2874	2874	2874	2874	2874	2874	2874	2874
24.0*	2855	2855	2855	2855	2855	2855	2855	2855
24.5*	2835	2835	2835	2835	2835	2835	2835	2835
25.0*	2820	2820	2820	2820	2820	2820	2820	2820

* These values are based on a yield and load optimized operation that is not feasible at all sites.

Nordex N131/3900 IEC S – Power curves – Mode 7

for hub heights 84 m, 114 m and 134 m (mode not available for 120 m)									
wind speed v_H [m/s]	Power P_{el} [kW] at air density ρ [kg/m ³]								
	0.900	0.925	0.950	0.975	1.000	1.025	1.050	1.075	1.100
3.0	1	3	4	5	7	8	9	10	12
3.5	52	55	58	60	63	66	69	71	74
4.0	122	127	132	136	141	146	150	155	159
4.5	210	217	225	232	239	246	253	260	267
5.0	317	327	337	347	357	367	377	387	397
5.5	442	456	469	483	496	509	523	536	550
6.0	589	606	624	641	659	676	694	711	728
6.5	760	782	804	826	849	871	893	915	937
7.0	958	986	1013	1041	1068	1096	1123	1151	1178
7.5	1175	1208	1242	1276	1309	1343	1377	1410	1444
8.0	1401	1441	1482	1522	1563	1603	1644	1685	1726
8.5	1628	1676	1724	1772	1821	1868	1918	1966	2015
9.0	1855	1910	1967	2023	2080	2136	2193	2249	2308
9.5	2084	2148	2212	2276	2342	2404	2470	2527	2580
10.0	2315	2386	2456	2526	2589	2643	2700	2747	2787
10.5	2539	2612	2671	2730	2781	2823	2866	2902	2930
11.0	2728	2788	2834	2880	2918	2947	2977	3001	3016
11.5	2869	2916	2948	2980	3005	3022	3040	3051	3054
12.0	2967	2999	3019	3038	3050	3055	3059	3060	3060
12.5	3026	3046	3052	3058	3060	3060	3060	3060	3060
13.0	3054	3060	3060	3060	3060	3060	3060	3060	3060
13.5	3060	3060	3060	3060	3060	3060	3060	3060	3060
14.0	3060	3060	3060	3060	3060	3060	3060	3060	3060
14.5	3060	3060	3060	3060	3060	3060	3060	3060	3060
15.0	3060	3060	3060	3060	3060	3060	3060	3060	3060
15.5	3060	3060	3060	3060	3060	3060	3060	3060	3060
16.0	3060	3060	3060	3060	3060	3060	3060	3060	3060
16.5	3060	3060	3060	3060	3060	3060	3060	3060	3060
17.0	3060	3060	3060	3060	3060	3060	3060	3060	3060
17.5	3060	3060	3060	3060	3060	3060	3060	3060	3060
18.0	3060	3060	3060	3060	3060	3060	3060	3060	3060
18.5	3060	3060	3060	3060	3060	3060	3060	3060	3060
19.0	3060	3060	3060	3060	3060	3060	3060	3060	3060
19.5	3060	3060	3060	3060	3060	3060	3060	3060	3060
20.0	3060	3060	3060	3060	3060	3060	3060	3060	3060
20.5*	3060	3060	3060	3060	3060	3060	3060	3060	3060
21.0*	3060	3060	3060	3060	3060	3060	3060	3060	3060
21.5*	3060	3060	3060	3060	3060	3060	3060	3060	3060
22.0*	3039	3039	3039	3039	3039	3039	3039	3039	3039
22.5*	2990	2990	2990	2990	2990	2990	2990	2990	2990
23.0*	2906	2906	2906	2906	2906	2906	2906	2906	2906
23.5*	2874	2874	2874	2874	2874	2874	2874	2874	2874
24.0*	2855	2855	2855	2855	2855	2855	2855	2855	2855
24.5*	2835	2835	2835	2835	2835	2835	2835	2835	2835
25.0*	2820	2820	2820	2820	2820	2820	2820	2820	2820

* These values are based on a yield and load optimized operation that is not feasible at all sites.

Nordex N131/3900 IEC S – Power curves – Mode 7

for hub heights 84 m, 114 m and 134 m (mode not available for 120 m)								
wind speed v_H [m/s]	Power P_{el} [kW] at air density ρ [kg/m ³]							
	1.125	1.150	1.175	1.200	1.225	1.250	1.275	1.300
3.0	13	14	15	17	18	19	21	22
3.5	77	79	82	85	87	90	93	95
4.0	164	169	173	178	182	187	192	196
4.5	274	281	288	295	302	309	316	323
5.0	407	417	427	437	447	457	466	476
5.5	563	577	590	603	617	630	644	657
6.0	746	763	781	798	815	833	850	867
6.5	959	981	1003	1025	1047	1069	1091	1113
7.0	1205	1233	1260	1287	1315	1342	1369	1396
7.5	1478	1512	1545	1579	1612	1646	1679	1712
8.0	1767	1808	1849	1889	1930	1969	2008	2048
8.5	2063	2112	2161	2209	2259	2307	2353	2394
9.0	2365	2422	2472	2516	2563	2607	2649	2683
9.5	2630	2680	2722	2755	2790	2823	2854	2878
10.0	2825	2864	2894	2917	2941	2964	2986	3000
10.5	2956	2983	3002	3014	3027	3039	3051	3056
11.0	3031	3046	3054	3055	3057	3059	3060	3060
11.5	3057	3060	3060	3060	3060	3060	3060	3060
12.0	3060	3060	3060	3060	3060	3060	3060	3060
12.5	3060	3060	3060	3060	3060	3060	3060	3060
13.0	3060	3060	3060	3060	3060	3060	3060	3060
13.5	3060	3060	3060	3060	3060	3060	3060	3060
14.0	3060	3060	3060	3060	3060	3060	3060	3060
14.5	3060	3060	3060	3060	3060	3060	3060	3060
15.0	3060	3060	3060	3060	3060	3060	3060	3060
15.5	3060	3060	3060	3060	3060	3060	3060	3060
16.0	3060	3060	3060	3060	3060	3060	3060	3060
16.5	3060	3060	3060	3060	3060	3060	3060	3060
17.0	3060	3060	3060	3060	3060	3060	3060	3060
17.5	3060	3060	3060	3060	3060	3060	3060	3060
18.0	3060	3060	3060	3060	3060	3060	3060	3060
18.5	3060	3060	3060	3060	3060	3060	3060	3060
19.0	3060	3060	3060	3060	3060	3060	3060	3060
19.5	3060	3060	3060	3060	3060	3060	3060	3060
20.0	3060	3060	3060	3060	3060	3060	3060	3060
20.5*	3060	3060	3060	3060	3060	3060	3060	3060
21.0*	3060	3060	3060	3060	3060	3060	3060	3060
21.5*	3060	3060	3060	3060	3060	3060	3060	3060
22.0*	3039	3039	3039	3039	3039	3039	3039	3039
22.5*	2990	2990	2990	2990	2990	2990	2990	2990
23.0*	2906	2906	2906	2906	2906	2906	2906	2906
23.5*	2874	2874	2874	2874	2874	2874	2874	2874
24.0*	2855	2855	2855	2855	2855	2855	2855	2855
24.5*	2835	2835	2835	2835	2835	2835	2835	2835
25.0*	2820	2820	2820	2820	2820	2820	2820	2820

* These values are based on a yield and load optimized operation that is not feasible at all sites.

Nordex N131/3900 IEC S – Power curves – Mode 8

for hub heights 84 m, 114 m, 120 m and 134 m									
wind speed v_H [m/s]	Power P_{el} [kW] at air density ρ [kg/m ³]								
	0.900	0.925	0.950	0.975	1.000	1.025	1.050	1.075	1.100
3.0	1	3	4	5	7	8	9	10	12
3.5	52	55	58	60	63	66	69	71	74
4.0	122	127	132	136	141	145	150	155	159
4.5	210	217	224	232	239	246	253	260	267
5.0	317	327	337	347	357	367	377	387	397
5.5	442	456	469	483	496	509	523	536	550
6.0	589	606	624	641	659	676	693	711	728
6.5	760	782	804	827	849	871	893	915	937
7.0	956	984	1011	1039	1066	1094	1121	1149	1176
7.5	1167	1200	1234	1268	1301	1335	1369	1403	1436
8.0	1384	1423	1464	1504	1545	1586	1627	1667	1708
8.5	1601	1646	1694	1741	1789	1838	1887	1934	1981
9.0	1815	1867	1921	1976	2032	2088	2144	2199	2255
9.5	2028	2086	2147	2209	2272	2336	2400	2452	2501
10.0	2238	2302	2369	2438	2497	2553	2608	2649	2686
10.5	2442	2509	2566	2623	2671	2713	2756	2785	2811
11.0	2615	2669	2713	2757	2793	2823	2853	2871	2886
11.5	2742	2785	2816	2848	2871	2889	2907	2913	2916
12.0	2832	2862	2881	2901	2911	2916	2920	2920	2920
12.5	2888	2906	2913	2919	2920	2920	2920	2920	2920
13.0	2914	2920	2920	2920	2920	2920	2920	2920	2920
13.5	2920	2920	2920	2920	2920	2920	2920	2920	2920
14.0	2920	2920	2920	2920	2920	2920	2920	2920	2920
14.5	2920	2920	2920	2920	2920	2920	2920	2920	2920
15.0	2920	2920	2920	2920	2920	2920	2920	2920	2920
15.5	2920	2920	2920	2920	2920	2920	2920	2920	2920
16.0	2920	2920	2920	2920	2920	2920	2920	2920	2920
16.5	2920	2920	2920	2920	2920	2920	2920	2920	2920
17.0	2920	2920	2920	2920	2920	2920	2920	2920	2920
17.5	2920	2920	2920	2920	2920	2920	2920	2920	2920
18.0	2920	2920	2920	2920	2920	2920	2920	2920	2920
18.5	2920	2920	2920	2920	2920	2920	2920	2920	2920
19.0	2920	2920	2920	2920	2920	2920	2920	2920	2920
19.5	2920	2920	2920	2920	2920	2920	2920	2920	2920
20.0	2920	2920	2920	2920	2920	2920	2920	2920	2920
20.5*	2920	2920	2920	2920	2920	2920	2920	2920	2920
21.0*	2920	2920	2920	2920	2920	2920	2920	2920	2920
21.5*	2920	2920	2920	2920	2920	2920	2920	2920	2920
22.0*	2920	2920	2920	2920	2920	2920	2920	2920	2920
22.5*	2916	2916	2916	2916	2916	2916	2916	2916	2916
23.0*	2901	2901	2901	2901	2901	2901	2901	2901	2901
23.5*	2874	2874	2874	2874	2874	2874	2874	2874	2874
24.0*	2855	2855	2855	2855	2855	2855	2855	2855	2855
24.5*	2835	2835	2835	2835	2835	2835	2835	2835	2835
25.0*	2820	2820	2820	2820	2820	2820	2820	2820	2820

* These values are based on a yield and load optimized operation that is not feasible at all sites.

Nordex N131/3900 IEC S – Power curves – Mode 8

for hub heights 84 m, 114 m, 120 m and 134 m								
wind speed v_H [m/s]	Power P_{el} [kW] at air density ρ [kg/m ³]							
	1.125	1.150	1.175	1.200	1.225	1.250	1.275	1.300
3.0	13	14	15	17	18	19	21	22
3.5	77	79	82	85	87	90	93	95
4.0	164	169	173	178	182	187	192	196
4.5	274	281	288	295	302	309	316	323
5.0	407	417	427	437	447	456	466	476
5.5	563	577	590	603	617	630	644	657
6.0	746	763	781	798	815	833	850	867
6.5	959	981	1003	1025	1047	1069	1091	1113
7.0	1204	1231	1258	1286	1313	1340	1368	1395
7.5	1470	1504	1537	1571	1604	1638	1671	1705
8.0	1748	1790	1830	1870	1910	1951	1991	2034
8.5	2029	2079	2126	2176	2223	2273	2314	2356
9.0	2310	2367	2411	2457	2500	2547	2580	2611
9.5	2551	2600	2633	2667	2700	2735	2758	2780
10.0	2724	2761	2783	2807	2830	2854	2867	2878
10.5	2838	2863	2875	2888	2900	2913	2916	2917
11.0	2901	2914	2915	2917	2919	2920	2920	2920
11.5	2919	2920	2920	2920	2920	2920	2920	2920
12.0	2920	2920	2920	2920	2920	2920	2920	2920
12.5	2920	2920	2920	2920	2920	2920	2920	2920
13.0	2920	2920	2920	2920	2920	2920	2920	2920
13.5	2920	2920	2920	2920	2920	2920	2920	2920
14.0	2920	2920	2920	2920	2920	2920	2920	2920
14.5	2920	2920	2920	2920	2920	2920	2920	2920
15.0	2920	2920	2920	2920	2920	2920	2920	2920
15.5	2920	2920	2920	2920	2920	2920	2920	2920
16.0	2920	2920	2920	2920	2920	2920	2920	2920
16.5	2920	2920	2920	2920	2920	2920	2920	2920
17.0	2920	2920	2920	2920	2920	2920	2920	2920
17.5	2920	2920	2920	2920	2920	2920	2920	2920
18.0	2920	2920	2920	2920	2920	2920	2920	2920
18.5	2920	2920	2920	2920	2920	2920	2920	2920
19.0	2920	2920	2920	2920	2920	2920	2920	2920
19.5	2920	2920	2920	2920	2920	2920	2920	2920
20.0	2920	2920	2920	2920	2920	2920	2920	2920
20.5*	2920	2920	2920	2920	2920	2920	2920	2920
21.0*	2920	2920	2920	2920	2920	2920	2920	2920
21.5*	2920	2920	2920	2920	2920	2920	2920	2920
22.0*	2920	2920	2920	2920	2920	2920	2920	2920
22.5*	2916	2916	2916	2916	2916	2916	2916	2916
23.0*	2901	2901	2901	2901	2901	2901	2901	2901
23.5*	2874	2874	2874	2874	2874	2874	2874	2874
24.0*	2855	2855	2855	2855	2855	2855	2855	2855
24.5*	2835	2835	2835	2835	2835	2835	2835	2835
25.0*	2820	2820	2820	2820	2820	2820	2820	2820

* These values are based on a yield and load optimized operation that is not feasible at all sites.

Nordex N131/3900 IEC S – Power curves – Mode 9

for hub heights 84 m, 114 m and 120 m (mode not available for 134 m)									
wind speed v_H [m/s]	Power P_{el} [kW] at air density ρ [kg/m ³]								
	0.900	0.925	0.950	0.975	1.000	1.025	1.050	1.075	1.100
3.0	1	3	4	5	7	8	9	10	12
3.5	52	55	58	60	63	66	69	71	74
4.0	122	127	132	136	141	145	150	155	159
4.5	210	217	224	232	239	246	253	260	267
5.0	317	327	337	347	357	367	377	387	397
5.5	442	456	469	482	496	509	523	536	550
6.0	589	606	624	641	659	676	693	711	728
6.5	761	783	805	827	849	871	893	915	938
7.0	953	981	1008	1036	1064	1091	1118	1146	1173
7.5	1157	1190	1224	1258	1291	1324	1358	1392	1425
8.0	1363	1402	1443	1483	1523	1563	1603	1643	1683
8.5	1567	1613	1661	1707	1755	1800	1848	1895	1941
9.0	1768	1821	1876	1930	1984	2036	2091	2143	2197
9.5	1969	2027	2090	2150	2211	2269	2332	2388	2436
10.0	2166	2231	2300	2367	2431	2480	2535	2582	2618
10.5	2360	2430	2493	2550	2602	2640	2683	2718	2743
11.0	2532	2591	2640	2684	2725	2752	2782	2805	2820
11.5	2663	2708	2745	2777	2805	2821	2839	2852	2855
12.0	2756	2789	2814	2833	2849	2854	2859	2860	2860
12.5	2817	2838	2850	2857	2860	2860	2860	2860	2860
13.0	2850	2858	2860	2860	2860	2860	2860	2860	2860
13.5	2860	2860	2860	2860	2860	2860	2860	2860	2860
14.0	2860	2860	2860	2860	2860	2860	2860	2860	2860
14.5	2860	2860	2860	2860	2860	2860	2860	2860	2860
15.0	2860	2860	2860	2860	2860	2860	2860	2860	2860
15.5	2860	2860	2860	2860	2860	2860	2860	2860	2860
16.0	2860	2860	2860	2860	2860	2860	2860	2860	2860
16.5	2860	2860	2860	2860	2860	2860	2860	2860	2860
17.0	2860	2860	2860	2860	2860	2860	2860	2860	2860
17.5	2860	2860	2860	2860	2860	2860	2860	2860	2860
18.0	2860	2860	2860	2860	2860	2860	2860	2860	2860
18.5	2860	2860	2860	2860	2860	2860	2860	2860	2860
19.0	2860	2860	2860	2860	2860	2860	2860	2860	2860
19.5	2860	2860	2860	2860	2860	2860	2860	2860	2860
20.0	2860	2860	2860	2860	2860	2860	2860	2860	2860
20.5*	2860	2860	2860	2860	2860	2860	2860	2860	2860
21.0*	2860	2860	2860	2860	2860	2860	2860	2860	2860
21.5*	2860	2860	2860	2860	2860	2860	2860	2860	2860
22.0*	2860	2860	2860	2860	2860	2860	2860	2860	2860
22.5*	2860	2860	2860	2860	2860	2860	2860	2860	2860
23.0*	2860	2860	2860	2860	2860	2860	2860	2860	2860
23.5*	2859	2859	2859	2859	2859	2859	2859	2859	2859
24.0*	2852	2852	2852	2852	2852	2852	2852	2852	2852
24.5*	2835	2835	2835	2835	2835	2835	2835	2835	2835
25.0*	2820	2820	2820	2820	2820	2820	2820	2820	2820

* These values are based on a yield and load optimized operation that is not feasible at all sites.

Nordex N131/3900 IEC S – Power curves – Mode 9

for hub heights 84 m, 114 m and 120 m (mode not available for 134 m)								
wind speed v_H [m/s]	Power P_{el} [kW] at air density ρ [kg/m ³]							
	1.125	1.150	1.175	1.200	1.225	1.250	1.275	1.300
3.0	13	14	15	17	18	19	21	22
3.5	77	79	82	85	87	90	93	95
4.0	164	169	173	178	182	187	192	196
4.5	274	281	288	295	302	309	316	323
5.0	407	417	427	437	446	456	466	476
5.5	563	576	590	603	617	630	643	657
6.0	746	763	781	798	815	833	850	867
6.5	960	982	1004	1026	1048	1069	1091	1113
7.0	1201	1228	1256	1283	1311	1338	1366	1393
7.5	1458	1492	1526	1561	1595	1629	1662	1695
8.0	1723	1763	1805	1847	1889	1929	1970	2011
8.5	1987	2034	2085	2136	2188	2235	2280	2319
9.0	2252	2307	2357	2405	2454	2498	2534	2563
9.5	2484	2533	2573	2609	2646	2678	2704	2724
10.0	2655	2692	2720	2746	2771	2794	2809	2819
10.5	2769	2795	2812	2825	2839	2851	2856	2857
11.0	2835	2850	2855	2857	2859	2860	2860	2860
11.5	2858	2860	2860	2860	2860	2860	2860	2860
12.0	2860	2860	2860	2860	2860	2860	2860	2860
12.5	2860	2860	2860	2860	2860	2860	2860	2860
13.0	2860	2860	2860	2860	2860	2860	2860	2860
13.5	2860	2860	2860	2860	2860	2860	2860	2860
14.0	2860	2860	2860	2860	2860	2860	2860	2860
14.5	2860	2860	2860	2860	2860	2860	2860	2860
15.0	2860	2860	2860	2860	2860	2860	2860	2860
15.5	2860	2860	2860	2860	2860	2860	2860	2860
16.0	2860	2860	2860	2860	2860	2860	2860	2860
16.5	2860	2860	2860	2860	2860	2860	2860	2860
17.0	2860	2860	2860	2860	2860	2860	2860	2860
17.5	2860	2860	2860	2860	2860	2860	2860	2860
18.0	2860	2860	2860	2860	2860	2860	2860	2860
18.5	2860	2860	2860	2860	2860	2860	2860	2860
19.0	2860	2860	2860	2860	2860	2860	2860	2860
19.5	2860	2860	2860	2860	2860	2860	2860	2860
20.0	2860	2860	2860	2860	2860	2860	2860	2860
20.5*	2860	2860	2860	2860	2860	2860	2860	2860
21.0*	2860	2860	2860	2860	2860	2860	2860	2860
21.5*	2860	2860	2860	2860	2860	2860	2860	2860
22.0*	2860	2860	2860	2860	2860	2860	2860	2860
22.5*	2860	2860	2860	2860	2860	2860	2860	2860
23.0*	2860	2860	2860	2860	2860	2860	2860	2860
23.5*	2859	2859	2859	2859	2859	2859	2859	2859
24.0*	2852	2852	2852	2852	2852	2852	2852	2852
24.5*	2835	2835	2835	2835	2835	2835	2835	2835
25.0*	2820	2820	2820	2820	2820	2820	2820	2820

* These values are based on a yield and load optimized operation that is not feasible at all sites.

Nordex N131/3900 IEC S – Power curves – Mode 10

for hub heights 84 m, 114 m and 120 m (mode not available for 134 m)									
wind speed v_H [m/s]	Power P_{el} [kW] at air density ρ [kg/m ³]								
	0.900	0.925	0.950	0.975	1.000	1.025	1.050	1.075	1.100
3.0	1	3	4	5	7	8	9	10	12
3.5	52	55	58	60	63	66	69	71	74
4.0	122	127	132	136	141	145	150	155	159
4.5	210	217	224	232	239	246	253	260	267
5.0	317	327	337	347	357	367	377	387	397
5.5	442	456	469	482	496	509	523	536	550
6.0	589	606	624	641	659	676	693	711	728
6.5	760	782	804	827	849	871	893	915	937
7.0	948	976	1004	1031	1058	1086	1113	1140	1168
7.5	1144	1178	1211	1244	1278	1311	1344	1377	1410
8.0	1340	1380	1420	1458	1498	1537	1577	1616	1656
8.5	1533	1579	1626	1671	1718	1763	1810	1856	1902
9.0	1726	1780	1835	1886	1941	1992	2047	2099	2153
9.5	1923	1984	2046	2103	2164	2222	2283	2338	2386
10.0	2120	2187	2254	2316	2380	2430	2482	2529	2565
10.5	2312	2383	2444	2497	2550	2588	2628	2663	2688
11.0	2483	2541	2590	2630	2670	2697	2725	2749	2762
11.5	2612	2656	2692	2721	2748	2764	2779	2792	2795
12.0	2703	2734	2757	2774	2790	2794	2798	2800	2800
12.5	2760	2779	2791	2796	2800	2800	2800	2800	2800
13.0	2791	2798	2800	2800	2800	2800	2800	2800	2800
13.5	2800	2800	2800	2800	2800	2800	2800	2800	2800
14.0	2800	2800	2800	2800	2800	2800	2800	2800	2800
14.5	2800	2800	2800	2800	2800	2800	2800	2800	2800
15.0	2800	2800	2800	2800	2800	2800	2800	2800	2800
15.5	2800	2800	2800	2800	2800	2800	2800	2800	2800
16.0	2800	2800	2800	2800	2800	2800	2800	2800	2800
16.5	2800	2800	2800	2800	2800	2800	2800	2800	2800
17.0	2800	2800	2800	2800	2800	2800	2800	2800	2800
17.5	2800	2800	2800	2800	2800	2800	2800	2800	2800
18.0	2800	2800	2800	2800	2800	2800	2800	2800	2800
18.5	2800	2800	2800	2800	2800	2800	2800	2800	2800
19.0	2800	2800	2800	2800	2800	2800	2800	2800	2800
19.5	2800	2800	2800	2800	2800	2800	2800	2800	2800
20.0	2800	2800	2800	2800	2800	2800	2800	2800	2800
20.5*	2800	2800	2800	2800	2800	2800	2800	2800	2800
21.0*	2800	2800	2800	2800	2800	2800	2800	2800	2800
21.5*	2800	2800	2800	2800	2800	2800	2800	2800	2800
22.0*	2800	2800	2800	2800	2800	2800	2800	2800	2800
22.5*	2800	2800	2800	2800	2800	2800	2800	2800	2800
23.0*	2800	2800	2800	2800	2800	2800	2800	2800	2800
23.5*	2800	2800	2800	2800	2800	2800	2800	2800	2800
24.0*	2800	2800	2800	2800	2800	2800	2800	2800	2800
24.5*	2800	2800	2800	2800	2800	2800	2800	2800	2800
25.0*	2800	2800	2800	2800	2800	2800	2800	2800	2800

* These values are based on a yield and load optimized operation that is not feasible at all sites.

Nordex N131/3900 IEC S – Power curves – Mode 10

for hub heights 84 m, 114 m and 120 m (mode not available for 134 m)								
wind speed v_H [m/s]	Power P_{el} [kW] at air density ρ [kg/m ³]							
	1.125	1.150	1.175	1.200	1.225	1.250	1.275	1.300
3.0	13	14	15	17	18	19	21	22
3.5	77	79	82	85	87	90	93	95
4.0	164	169	173	178	182	187	192	196
4.5	274	281	288	295	302	309	316	323
5.0	407	417	427	436	446	456	466	476
5.5	563	576	590	603	617	630	643	657
6.0	746	763	780	798	815	833	850	867
6.5	959	981	1003	1025	1047	1069	1091	1113
7.0	1195	1223	1251	1278	1306	1333	1360	1388
7.5	1444	1478	1512	1546	1580	1614	1647	1681
8.0	1695	1737	1779	1819	1861	1902	1941	1983
8.5	1949	1998	2049	2097	2147	2196	2238	2278
9.0	2207	2263	2312	2357	2403	2448	2483	2513
9.5	2433	2483	2522	2555	2590	2623	2648	2668
10.0	2601	2638	2666	2689	2712	2735	2750	2760
10.5	2713	2739	2754	2767	2779	2791	2797	2797
11.0	2776	2790	2795	2797	2799	2800	2800	2800
11.5	2798	2800	2800	2800	2800	2800	2800	2800
12.0	2800	2800	2800	2800	2800	2800	2800	2800
12.5	2800	2800	2800	2800	2800	2800	2800	2800
13.0	2800	2800	2800	2800	2800	2800	2800	2800
13.5	2800	2800	2800	2800	2800	2800	2800	2800
14.0	2800	2800	2800	2800	2800	2800	2800	2800
14.5	2800	2800	2800	2800	2800	2800	2800	2800
15.0	2800	2800	2800	2800	2800	2800	2800	2800
15.5	2800	2800	2800	2800	2800	2800	2800	2800
16.0	2800	2800	2800	2800	2800	2800	2800	2800
16.5	2800	2800	2800	2800	2800	2800	2800	2800
17.0	2800	2800	2800	2800	2800	2800	2800	2800
17.5	2800	2800	2800	2800	2800	2800	2800	2800
18.0	2800	2800	2800	2800	2800	2800	2800	2800
18.5	2800	2800	2800	2800	2800	2800	2800	2800
19.0	2800	2800	2800	2800	2800	2800	2800	2800
19.5	2800	2800	2800	2800	2800	2800	2800	2800
20.0	2800	2800	2800	2800	2800	2800	2800	2800
20.5*	2800	2800	2800	2800	2800	2800	2800	2800
21.0*	2800	2800	2800	2800	2800	2800	2800	2800
21.5*	2800	2800	2800	2800	2800	2800	2800	2800
22.0*	2800	2800	2800	2800	2800	2800	2800	2800
22.5*	2800	2800	2800	2800	2800	2800	2800	2800
23.0*	2800	2800	2800	2800	2800	2800	2800	2800
23.5*	2800	2800	2800	2800	2800	2800	2800	2800
24.0*	2800	2800	2800	2800	2800	2800	2800	2800
24.5*	2800	2800	2800	2800	2800	2800	2800	2800
25.0*	2800	2800	2800	2800	2800	2800	2800	2800

* These values are based on a yield and load optimized operation that is not feasible at all sites.

Nordex N131/3900 IEC S – Power curves – Mode 11

for hub heights 84 m, 114 m and 120 m (mode not available for 134 m)									
wind speed v_H [m/s]	Power P_{el} [kW] at air density ρ [kg/m ³]								
	0.900	0.925	0.950	0.975	1.000	1.025	1.050	1.075	1.100
3.0	1	3	4	5	7	8	9	10	12
3.5	52	55	58	60	63	66	69	71	74
4.0	122	127	132	136	141	145	150	155	159
4.5	210	217	224	232	239	246	253	260	267
5.0	317	327	337	347	357	367	377	387	397
5.5	442	455	469	482	496	509	523	536	550
6.0	589	606	624	641	659	676	694	711	728
6.5	759	781	803	825	847	869	891	913	935
7.0	941	968	995	1023	1051	1078	1106	1133	1160
7.5	1128	1161	1193	1227	1261	1294	1327	1360	1393
8.0	1314	1352	1389	1430	1471	1509	1548	1587	1625
8.5	1497	1540	1583	1631	1678	1722	1768	1812	1856
9.0	1678	1727	1774	1830	1884	1933	1985	2034	2084
9.5	1857	1912	1964	2026	2086	2140	2198	2253	2306
10.0	2034	2094	2150	2219	2284	2341	2390	2437	2481
10.5	2207	2271	2331	2396	2450	2497	2535	2571	2603
11.0	2373	2429	2478	2530	2572	2608	2634	2660	2682
11.5	2504	2548	2587	2626	2655	2680	2696	2711	2723
12.0	2601	2634	2662	2688	2706	2720	2725	2728	2730
12.5	2668	2690	2707	2721	2727	2730	2730	2730	2730
13.0	2710	2720	2727	2730	2730	2730	2730	2730	2730
13.5	2728	2730	2730	2730	2730	2730	2730	2730	2730
14.0	2730	2730	2730	2730	2730	2730	2730	2730	2730
14.5	2730	2730	2730	2730	2730	2730	2730	2730	2730
15.0	2730	2730	2730	2730	2730	2730	2730	2730	2730
15.5	2730	2730	2730	2730	2730	2730	2730	2730	2730
16.0	2730	2730	2730	2730	2730	2730	2730	2730	2730
16.5	2730	2730	2730	2730	2730	2730	2730	2730	2730
17.0	2730	2730	2730	2730	2730	2730	2730	2730	2730
17.5	2730	2730	2730	2730	2730	2730	2730	2730	2730
18.0	2730	2730	2730	2730	2730	2730	2730	2730	2730
18.5	2730	2730	2730	2730	2730	2730	2730	2730	2730
19.0	2730	2730	2730	2730	2730	2730	2730	2730	2730
19.5	2730	2730	2730	2730	2730	2730	2730	2730	2730
20.0	2730	2730	2730	2730	2730	2730	2730	2730	2730
20.5*	2730	2730	2730	2730	2730	2730	2730	2730	2730
21.0*	2730	2730	2730	2730	2730	2730	2730	2730	2730
21.5*	2730	2730	2730	2730	2730	2730	2730	2730	2730
22.0*	2730	2730	2730	2730	2730	2730	2730	2730	2730
22.5*	2730	2730	2730	2730	2730	2730	2730	2730	2730
23.0*	2730	2730	2730	2730	2730	2730	2730	2730	2730
23.5*	2730	2730	2730	2730	2730	2730	2730	2730	2730
24.0*	2730	2730	2730	2730	2730	2730	2730	2730	2730
24.5*	2730	2730	2730	2730	2730	2730	2730	2730	2730
25.0*	2730	2730	2730	2730	2730	2730	2730	2730	2730

* These values are based on a yield and load optimized operation that is not feasible at all sites.

Nordex N131/3900 IEC S – Power curves – Mode 11

for hub heights 84 m, 114 m and 120 m (mode not available for 134 m)								
wind speed v_H [m/s]	Power P_{el} [kW] at air density ρ [kg/m ³]							
	1.125	1.150	1.175	1.200	1.225	1.250	1.275	1.300
3.0	13	14	15	17	18	19	21	22
3.5	77	79	82	85	87	90	93	95
4.0	164	169	173	178	182	187	192	196
4.5	274	281	288	295	302	309	316	323
5.0	407	417	427	436	446	456	466	476
5.5	563	576	590	603	617	630	643	657
6.0	746	763	781	798	815	833	850	867
6.5	957	980	1002	1024	1046	1068	1090	1112
7.0	1187	1215	1243	1270	1298	1325	1353	1380
7.5	1426	1460	1494	1527	1562	1596	1628	1662
8.0	1664	1705	1746	1786	1827	1867	1905	1947
8.5	1900	1948	1996	2043	2093	2140	2185	2225
9.0	2135	2190	2246	2289	2335	2378	2419	2449
9.5	2351	2399	2448	2481	2515	2548	2578	2598
10.0	2515	2552	2589	2611	2635	2657	2678	2688
10.5	2627	2653	2678	2690	2703	2715	2726	2727
11.0	2695	2710	2724	2726	2728	2729	2730	2730
11.5	2725	2728	2730	2730	2730	2730	2730	2730
12.0	2730	2730	2730	2730	2730	2730	2730	2730
12.5	2730	2730	2730	2730	2730	2730	2730	2730
13.0	2730	2730	2730	2730	2730	2730	2730	2730
13.5	2730	2730	2730	2730	2730	2730	2730	2730
14.0	2730	2730	2730	2730	2730	2730	2730	2730
14.5	2730	2730	2730	2730	2730	2730	2730	2730
15.0	2730	2730	2730	2730	2730	2730	2730	2730
15.5	2730	2730	2730	2730	2730	2730	2730	2730
16.0	2730	2730	2730	2730	2730	2730	2730	2730
16.5	2730	2730	2730	2730	2730	2730	2730	2730
17.0	2730	2730	2730	2730	2730	2730	2730	2730
17.5	2730	2730	2730	2730	2730	2730	2730	2730
18.0	2730	2730	2730	2730	2730	2730	2730	2730
18.5	2730	2730	2730	2730	2730	2730	2730	2730
19.0	2730	2730	2730	2730	2730	2730	2730	2730
19.5	2730	2730	2730	2730	2730	2730	2730	2730
20.0	2730	2730	2730	2730	2730	2730	2730	2730
20.5*	2730	2730	2730	2730	2730	2730	2730	2730
21.0*	2730	2730	2730	2730	2730	2730	2730	2730
21.5*	2730	2730	2730	2730	2730	2730	2730	2730
22.0*	2730	2730	2730	2730	2730	2730	2730	2730
22.5*	2730	2730	2730	2730	2730	2730	2730	2730
23.0*	2730	2730	2730	2730	2730	2730	2730	2730
23.5*	2730	2730	2730	2730	2730	2730	2730	2730
24.0*	2730	2730	2730	2730	2730	2730	2730	2730
24.5*	2730	2730	2730	2730	2730	2730	2730	2730
25.0*	2730	2730	2730	2730	2730	2730	2730	2730

* These values are based on a yield and load optimized operation that is not feasible at all sites.

Nordex N131/3900 IEC S – Power curves – Mode 12

for hub heights 84 m, 114 m and 120 m (mode not available for 134 m)									
wind speed v_H [m/s]	Power P_{el} [kW] at air density ρ [kg/m ³]								
	0.900	0.925	0.950	0.975	1.000	1.025	1.050	1.075	1.100
3.0	1	3	4	5	7	8	9	10	12
3.5	52	55	58	60	63	66	69	71	74
4.0	122	127	132	136	141	145	150	155	159
4.5	210	217	224	232	239	246	253	260	267
5.0	317	327	337	347	357	367	377	387	397
5.5	442	455	469	482	496	509	523	536	549
6.0	590	607	625	642	659	677	694	712	729
6.5	756	778	800	823	845	867	889	911	933
7.0	932	959	987	1014	1041	1068	1095	1122	1150
7.5	1109	1142	1175	1207	1240	1272	1304	1337	1370
8.0	1284	1322	1361	1399	1437	1474	1511	1550	1589
8.5	1457	1500	1545	1588	1631	1673	1715	1760	1806
9.0	1629	1676	1727	1775	1824	1871	1918	1969	2020
9.5	1798	1851	1907	1960	2015	2066	2118	2174	2232
10.0	1965	2022	2083	2142	2201	2258	2308	2356	2406
10.5	2128	2190	2256	2317	2367	2414	2455	2492	2530
11.0	2287	2349	2403	2454	2492	2529	2558	2584	2611
11.5	2421	2470	2513	2552	2579	2606	2626	2641	2657
12.0	2521	2559	2590	2618	2635	2652	2662	2666	2670
12.5	2592	2620	2640	2657	2663	2669	2670	2670	2670
13.0	2639	2656	2664	2670	2670	2670	2670	2670	2670
13.5	2664	2670	2670	2670	2670	2670	2670	2670	2670
14.0	2670	2670	2670	2670	2670	2670	2670	2670	2670
14.5	2670	2670	2670	2670	2670	2670	2670	2670	2670
15.0	2670	2670	2670	2670	2670	2670	2670	2670	2670
15.5	2670	2670	2670	2670	2670	2670	2670	2670	2670
16.0	2670	2670	2670	2670	2670	2670	2670	2670	2670
16.5	2670	2670	2670	2670	2670	2670	2670	2670	2670
17.0	2670	2670	2670	2670	2670	2670	2670	2670	2670
17.5	2670	2670	2670	2670	2670	2670	2670	2670	2670
18.0	2670	2670	2670	2670	2670	2670	2670	2670	2670
18.5	2670	2670	2670	2670	2670	2670	2670	2670	2670
19.0	2670	2670	2670	2670	2670	2670	2670	2670	2670
19.5	2670	2670	2670	2670	2670	2670	2670	2670	2670
20.0	2670	2670	2670	2670	2670	2670	2670	2670	2670
20.5*	2670	2670	2670	2670	2670	2670	2670	2670	2670
21.0*	2670	2670	2670	2670	2670	2670	2670	2670	2670
21.5*	2670	2670	2670	2670	2670	2670	2670	2670	2670
22.0*	2670	2670	2670	2670	2670	2670	2670	2670	2670

* These values are based on a yield and load optimized operation that is not feasible at all sites.

Nordex N131/3900 IEC S – Power curves – Mode 12

for hub heights 84 m, 114 m and 120 m (mode not available for 134 m)								
wind speed v_H [m/s]	Power P_{el} [kW] at air density ρ [kg/m ³]							
	1.125	1.150	1.175	1.200	1.225	1.250	1.275	1.300
3.0	13	14	15	17	18	19	21	22
3.5	77	79	82	85	87	90	93	95
4.0	164	169	173	178	182	187	192	196
4.5	274	281	288	295	302	309	316	323
5.0	407	417	426	436	446	456	466	476
5.5	563	576	590	603	617	630	643	657
6.0	747	764	781	799	816	834	851	868
6.5	955	977	999	1021	1043	1065	1087	1109
7.0	1177	1205	1232	1260	1287	1315	1341	1369
7.5	1404	1437	1470	1504	1537	1570	1602	1636
8.0	1629	1669	1707	1748	1787	1826	1863	1902
8.5	1852	1898	1942	1989	2035	2081	2124	2168
9.0	2072	2125	2176	2226	2268	2310	2350	2387
9.5	2282	2329	2374	2415	2446	2477	2507	2534
10.0	2445	2480	2514	2544	2566	2587	2608	2625
10.5	2558	2583	2606	2626	2637	2649	2660	2667
11.0	2629	2643	2656	2665	2667	2668	2670	2670
11.5	2664	2667	2670	2670	2670	2670	2670	2670
12.0	2670	2670	2670	2670	2670	2670	2670	2670
12.5	2670	2670	2670	2670	2670	2670	2670	2670
13.0	2670	2670	2670	2670	2670	2670	2670	2670
13.5	2670	2670	2670	2670	2670	2670	2670	2670
14.0	2670	2670	2670	2670	2670	2670	2670	2670
14.5	2670	2670	2670	2670	2670	2670	2670	2670
15.0	2670	2670	2670	2670	2670	2670	2670	2670
15.5	2670	2670	2670	2670	2670	2670	2670	2670
16.0	2670	2670	2670	2670	2670	2670	2670	2670
16.5	2670	2670	2670	2670	2670	2670	2670	2670
17.0	2670	2670	2670	2670	2670	2670	2670	2670
17.5	2670	2670	2670	2670	2670	2670	2670	2670
18.0	2670	2670	2670	2670	2670	2670	2670	2670
18.5	2670	2670	2670	2670	2670	2670	2670	2670
19.0	2670	2670	2670	2670	2670	2670	2670	2670
19.5	2670	2670	2670	2670	2670	2670	2670	2670
20.0	2670	2670	2670	2670	2670	2670	2670	2670
20.5*	2670	2670	2670	2670	2670	2670	2670	2670
21.0*	2670	2670	2670	2670	2670	2670	2670	2670
21.5*	2670	2670	2670	2670	2670	2670	2670	2670
22.0*	2670	2670	2670	2670	2670	2670	2670	2670

* These values are based on a yield and load optimized operation that is not feasible at all sites.

Nordex N131/3900 IEC S – Power curves – Mode 13

for hub heights 84 m, 114 m, 120 m and 134 m									
wind speed v_H [m/s]	Power P_{el} [kW] at air density ρ [kg/m ³]								
	0.900	0.925	0.950	0.975	1.000	1.025	1.050	1.075	1.100
3.0	1	3	4	5	7	8	9	10	12
3.5	52	55	58	60	63	66	69	71	74
4.0	122	127	132	136	141	145	150	155	159
4.5	210	217	224	231	239	246	253	260	267
5.0	317	327	337	347	357	367	377	387	397
5.5	442	455	469	482	496	509	523	536	549
6.0	589	607	624	642	659	677	694	711	729
6.5	752	774	796	818	840	862	884	906	928
7.0	920	947	975	1001	1028	1055	1082	1109	1136
7.5	1087	1120	1153	1184	1215	1247	1280	1312	1345
8.0	1252	1290	1329	1364	1400	1437	1475	1513	1551
8.5	1415	1458	1503	1543	1584	1627	1671	1715	1761
9.0	1577	1626	1678	1724	1771	1821	1871	1921	1972
9.5	1742	1798	1856	1907	1959	2014	2069	2124	2179
10.0	1908	1969	2032	2087	2144	2203	2257	2303	2351
10.5	2072	2137	2202	2261	2310	2359	2403	2438	2474
11.0	2231	2296	2349	2397	2435	2472	2504	2529	2553
11.5	2365	2417	2458	2495	2522	2547	2568	2583	2596
12.0	2465	2504	2533	2559	2576	2591	2602	2606	2610
12.5	2534	2562	2580	2597	2603	2608	2610	2610	2610
13.0	2580	2597	2604	2610	2610	2610	2610	2610	2610
13.5	2603	2610	2610	2610	2610	2610	2610	2610	2610
14.0	2610	2610	2610	2610	2610	2610	2610	2610	2610
14.5	2610	2610	2610	2610	2610	2610	2610	2610	2610
15.0	2610	2610	2610	2610	2610	2610	2610	2610	2610
15.5	2610	2610	2610	2610	2610	2610	2610	2610	2610
16.0	2610	2610	2610	2610	2610	2610	2610	2610	2610
16.5	2610	2610	2610	2610	2610	2610	2610	2610	2610
17.0	2610	2610	2610	2610	2610	2610	2610	2610	2610
17.5	2610	2610	2610	2610	2610	2610	2610	2610	2610
18.0	2610	2610	2610	2610	2610	2610	2610	2610	2610
18.5	2610	2610	2610	2610	2610	2610	2610	2610	2610
19.0	2610	2610	2610	2610	2610	2610	2610	2610	2610
19.5	2610	2610	2610	2610	2610	2610	2610	2610	2610
20.0	2610	2610	2610	2610	2610	2610	2610	2610	2610

* These values are based on a yield and load optimized operation that is not feasible at all sites.

Nordex N131/3900 IEC S – Power curves – Mode 13

for hub heights 84 m, 114 m, 120 m and 134 m								
wind speed v_H [m/s]	Power P_{el} [kW] at air density ρ [kg/m ³]							
	1.125	1.150	1.175	1.200	1.225	1.250	1.275	1.300
3.0	13	14	15	17	18	19	21	22
3.5	77	79	82	85	87	90	93	95
4.0	164	169	173	178	182	187	192	196
4.5	274	281	288	295	302	309	316	323
5.0	407	417	426	436	446	456	466	476
5.5	563	576	590	603	616	630	643	657
6.0	746	764	781	799	816	833	851	868
6.5	950	972	994	1016	1039	1061	1083	1105
7.0	1163	1191	1218	1245	1273	1300	1327	1355
7.5	1377	1410	1443	1475	1509	1542	1575	1609
8.0	1589	1628	1668	1706	1747	1786	1825	1865
8.5	1804	1850	1896	1940	1988	2034	2079	2122
9.0	2021	2073	2124	2172	2215	2256	2298	2335
9.5	2228	2273	2318	2358	2390	2421	2452	2479
10.0	2389	2424	2457	2487	2509	2530	2550	2567
10.5	2502	2525	2547	2567	2578	2589	2600	2607
11.0	2571	2583	2595	2605	2607	2608	2610	2610
11.5	2604	2607	2609	2610	2610	2610	2610	2610
12.0	2610	2610	2610	2610	2610	2610	2610	2610
12.5	2610	2610	2610	2610	2610	2610	2610	2610
13.0	2610	2610	2610	2610	2610	2610	2610	2610
13.5	2610	2610	2610	2610	2610	2610	2610	2610
14.0	2610	2610	2610	2610	2610	2610	2610	2610
14.5	2610	2610	2610	2610	2610	2610	2610	2610
15.0	2610	2610	2610	2610	2610	2610	2610	2610
15.5	2610	2610	2610	2610	2610	2610	2610	2610
16.0	2610	2610	2610	2610	2610	2610	2610	2610
16.5	2610	2610	2610	2610	2610	2610	2610	2610
17.0	2610	2610	2610	2610	2610	2610	2610	2610
17.5	2610	2610	2610	2610	2610	2610	2610	2610
18.0	2610	2610	2610	2610	2610	2610	2610	2610
18.5	2610	2610	2610	2610	2610	2610	2610	2610
19.0	2610	2610	2610	2610	2610	2610	2610	2610
19.5	2610	2610	2610	2610	2610	2610	2610	2610
20.0	2610	2610	2610	2610	2610	2610	2610	2610

* These values are based on a yield and load optimized operation that is not feasible at all sites.

Nordex N131/3900 IEC S – General remarks thrust curves

Basis:

The represented thrust coefficients are based on aerodynamical calculations by the Nordex Energy SE & Co. KG. The thrust curves are only for information and will not be warranted.

Nordex N131/3900 IEC S – Thrust curves – Mode 0

for hub heights 84 m, 114 m, 120 m and 134 m									
wind speed v_H [m/s]	Thrust coefficients c_T at air density ρ [kg/m ³]								
	0.900	0.925	0.950	0.975	1.000	1.025	1.050	1.075	1.100
3.0	0.902	0.902	0.902	0.902	0.903	0.904	0.905	0.906	0.907
3.5	0.894	0.895	0.896	0.897	0.897	0.898	0.899	0.899	0.900
4.0	0.887	0.887	0.888	0.888	0.889	0.889	0.889	0.890	0.890
4.5	0.879	0.879	0.880	0.880	0.880	0.880	0.880	0.880	0.880
5.0	0.872	0.872	0.872	0.872	0.872	0.871	0.871	0.871	0.871
5.5	0.863	0.863	0.862	0.862	0.862	0.862	0.861	0.861	0.861
6.0	0.857	0.857	0.856	0.856	0.856	0.855	0.855	0.855	0.854
6.5	0.854	0.854	0.853	0.853	0.853	0.852	0.852	0.852	0.852
7.0	0.852	0.851	0.851	0.851	0.850	0.850	0.850	0.850	0.850
7.5	0.850	0.849	0.849	0.849	0.848	0.848	0.848	0.848	0.848
8.0	0.847	0.847	0.847	0.847	0.847	0.846	0.846	0.846	0.846
8.5	0.821	0.821	0.820	0.820	0.820	0.820	0.820	0.820	0.820
9.0	0.794	0.794	0.793	0.793	0.793	0.793	0.793	0.793	0.793
9.5	0.755	0.754	0.754	0.754	0.753	0.753	0.753	0.752	0.752
10.0	0.714	0.713	0.712	0.711	0.710	0.709	0.708	0.707	0.706
10.5	0.675	0.674	0.672	0.671	0.670	0.668	0.667	0.665	0.663
11.0	0.639	0.637	0.636	0.634	0.632	0.630	0.628	0.612	0.590
11.5	0.605	0.603	0.602	0.579	0.557	0.538	0.520	0.504	0.490
12.0	0.540	0.519	0.501	0.484	0.469	0.455	0.442	0.430	0.418
12.5	0.458	0.443	0.429	0.416	0.404	0.393	0.382	0.372	0.363
13.0	0.397	0.385	0.374	0.363	0.353	0.343	0.334	0.326	0.318
13.5	0.349	0.338	0.329	0.320	0.311	0.303	0.296	0.288	0.282
14.0	0.309	0.300	0.292	0.284	0.277	0.270	0.263	0.257	0.251
14.5	0.276	0.268	0.261	0.254	0.248	0.242	0.236	0.230	0.225
15.0	0.248	0.241	0.235	0.228	0.223	0.217	0.212	0.208	0.203
15.5	0.224	0.218	0.212	0.207	0.202	0.197	0.192	0.188	0.184
16.0	0.203	0.198	0.193	0.188	0.183	0.179	0.175	0.171	0.167
16.5	0.185	0.180	0.176	0.171	0.167	0.163	0.160	0.156	0.153
17.0	0.169	0.165	0.161	0.157	0.153	0.150	0.146	0.143	0.140
17.5	0.155	0.151	0.148	0.144	0.141	0.138	0.134	0.132	0.129
18.0	0.143	0.140	0.136	0.133	0.130	0.127	0.124	0.122	0.119
18.5	0.132	0.129	0.126	0.123	0.120	0.117	0.115	0.112	0.110
19.0	0.122	0.119	0.117	0.114	0.111	0.109	0.107	0.104	0.102
19.5	0.114	0.111	0.108	0.106	0.104	0.101	0.099	0.097	0.095
20.0	0.106	0.103	0.101	0.099	0.096	0.094	0.092	0.091	0.089
20.5*	0.098	0.095	0.093	0.092	0.089	0.087	0.085	0.084	0.082
21.0*	0.089	0.087	0.085	0.084	0.081	0.079	0.078	0.077	0.075
21.5*	0.080	0.078	0.076	0.075	0.072	0.071	0.069	0.069	0.067
22.0*	0.070	0.068	0.066	0.065	0.063	0.062	0.060	0.060	0.058
22.5*	0.059	0.058	0.057	0.055	0.054	0.053	0.052	0.051	0.050
23.0*	0.054	0.053	0.052	0.051	0.049	0.048	0.047	0.047	0.045
23.5*	0.051	0.050	0.049	0.048	0.046	0.045	0.044	0.044	0.043
24.0*	0.048	0.047	0.046	0.045	0.043	0.043	0.042	0.041	0.040
24.5*	0.045	0.044	0.043	0.042	0.041	0.040	0.039	0.039	0.038
25.0*	0.042	0.041	0.040	0.039	0.038	0.037	0.036	0.036	0.035

* These values are based on a yield and load optimized operation that is not feasible at all sites.

Nordex N131/3900 IEC S – Thrust curves – Mode 0

for hub heights 84 m, 114 m, 120 m and 134 m								
wind speed v_H [m/s]	Thrust coefficients c_T at air density ρ [kg/m ³]							
	1.125	1.150	1.175	1.200	1.225	1.250	1.275	1.300
3.0	0.907	0.909	0.910	0.910	0.911	0.912	0.912	0.913
3.5	0.901	0.901	0.902	0.902	0.903	0.903	0.904	0.904
4.0	0.890	0.891	0.891	0.891	0.891	0.892	0.892	0.892
4.5	0.880	0.880	0.880	0.881	0.881	0.881	0.881	0.881
5.0	0.871	0.871	0.871	0.871	0.871	0.871	0.871	0.871
5.5	0.861	0.860	0.860	0.860	0.860	0.860	0.860	0.860
6.0	0.854	0.854	0.854	0.853	0.853	0.853	0.853	0.852
6.5	0.852	0.851	0.851	0.851	0.851	0.850	0.850	0.850
7.0	0.849	0.849	0.849	0.849	0.849	0.848	0.848	0.848
7.5	0.848	0.847	0.847	0.847	0.847	0.847	0.846	0.846
8.0	0.846	0.846	0.846	0.846	0.845	0.845	0.845	0.845
8.5	0.820	0.820	0.820	0.820	0.820	0.820	0.820	0.820
9.0	0.793	0.793	0.793	0.793	0.793	0.793	0.793	0.793
9.5	0.751	0.751	0.750	0.749	0.748	0.748	0.747	0.746
10.0	0.704	0.703	0.701	0.699	0.697	0.695	0.693	0.690
10.5	0.661	0.659	0.656	0.644	0.622	0.602	0.584	0.568
11.0	0.570	0.553	0.536	0.522	0.508	0.495	0.483	0.471
11.5	0.476	0.463	0.451	0.440	0.430	0.420	0.410	0.401
12.0	0.407	0.397	0.388	0.379	0.370	0.362	0.354	0.347
12.5	0.354	0.345	0.338	0.330	0.323	0.316	0.310	0.303
13.0	0.311	0.304	0.297	0.290	0.284	0.278	0.273	0.268
13.5	0.275	0.269	0.263	0.258	0.252	0.247	0.242	0.238
14.0	0.245	0.240	0.235	0.230	0.225	0.221	0.217	0.213
14.5	0.220	0.215	0.211	0.207	0.202	0.199	0.195	0.191
15.0	0.198	0.194	0.190	0.187	0.183	0.179	0.176	0.173
15.5	0.180	0.176	0.173	0.169	0.166	0.163	0.160	0.157
16.0	0.164	0.160	0.157	0.154	0.151	0.148	0.146	0.143
16.5	0.150	0.147	0.144	0.141	0.138	0.136	0.133	0.131
17.0	0.137	0.134	0.132	0.129	0.127	0.125	0.123	0.120
17.5	0.126	0.124	0.122	0.119	0.117	0.115	0.113	0.111
18.0	0.117	0.114	0.112	0.110	0.108	0.106	0.104	0.103
18.5	0.108	0.106	0.104	0.102	0.100	0.098	0.097	0.095
19.0	0.100	0.098	0.096	0.095	0.093	0.092	0.090	0.088
19.5	0.093	0.092	0.090	0.088	0.087	0.085	0.084	0.082
20.0	0.087	0.086	0.084	0.082	0.081	0.080	0.078	0.077
20.5*	0.080	0.080	0.078	0.076	0.075	0.074	0.072	0.071
21.0*	0.073	0.073	0.071	0.069	0.068	0.068	0.066	0.065
21.5*	0.066	0.065	0.063	0.062	0.061	0.060	0.059	0.058
22.0*	0.057	0.056	0.055	0.054	0.053	0.052	0.051	0.051
22.5*	0.049	0.048	0.047	0.046	0.045	0.045	0.044	0.043
23.0*	0.044	0.044	0.043	0.042	0.041	0.041	0.040	0.039
23.5*	0.042	0.041	0.040	0.040	0.039	0.039	0.038	0.037
24.0*	0.039	0.039	0.038	0.037	0.037	0.036	0.035	0.035
24.5*	0.037	0.036	0.036	0.035	0.034	0.034	0.033	0.033
25.0*	0.034	0.034	0.033	0.032	0.032	0.032	0.031	0.030

* These values are based on a yield and load optimized operation that is not feasible at all sites.

Nordex N131/3900 IEC S – Thrust curves – Mode 1

for hub heights 84 m, 114 m, 120 m and 134 m									
wind speed v_H [m/s]	Thrust coefficients c_T at air density ρ [kg/m ³]								
	0.900	0.925	0.950	0.975	1.000	1.025	1.050	1.075	1.100
3.0	0.902	0.902	0.902	0.902	0.903	0.904	0.905	0.906	0.907
3.5	0.894	0.895	0.896	0.897	0.897	0.898	0.899	0.900	0.900
4.0	0.887	0.887	0.888	0.888	0.889	0.889	0.889	0.890	0.890
4.5	0.879	0.880	0.880	0.880	0.880	0.880	0.880	0.880	0.880
5.0	0.872	0.872	0.872	0.872	0.872	0.872	0.872	0.872	0.871
5.5	0.863	0.863	0.863	0.862	0.862	0.862	0.862	0.862	0.861
6.0	0.857	0.857	0.857	0.856	0.856	0.856	0.855	0.855	0.855
6.5	0.854	0.854	0.854	0.853	0.853	0.853	0.852	0.852	0.852
7.0	0.852	0.852	0.851	0.851	0.851	0.850	0.850	0.850	0.850
7.5	0.850	0.850	0.849	0.849	0.849	0.849	0.848	0.848	0.848
8.0	0.847	0.847	0.847	0.847	0.847	0.847	0.847	0.846	0.846
8.5	0.821	0.821	0.821	0.821	0.821	0.821	0.821	0.821	0.821
9.0	0.792	0.792	0.792	0.792	0.792	0.792	0.792	0.792	0.792
9.5	0.748	0.748	0.747	0.747	0.746	0.746	0.745	0.744	0.744
10.0	0.707	0.706	0.706	0.704	0.704	0.702	0.701	0.700	0.699
10.5	0.668	0.667	0.666	0.665	0.663	0.662	0.660	0.659	0.657
11.0	0.632	0.631	0.629	0.628	0.626	0.625	0.611	0.589	0.569
11.5	0.599	0.597	0.580	0.558	0.538	0.520	0.503	0.488	0.474
12.0	0.522	0.502	0.485	0.469	0.454	0.441	0.428	0.417	0.406
12.5	0.444	0.430	0.416	0.404	0.392	0.381	0.371	0.361	0.352
13.0	0.386	0.374	0.363	0.353	0.343	0.334	0.325	0.317	0.309
13.5	0.339	0.329	0.320	0.311	0.303	0.295	0.288	0.280	0.274
14.0	0.301	0.292	0.284	0.276	0.269	0.262	0.256	0.250	0.244
14.5	0.269	0.261	0.254	0.247	0.241	0.235	0.230	0.224	0.219
15.0	0.241	0.235	0.228	0.223	0.217	0.212	0.207	0.202	0.198
15.5	0.218	0.212	0.207	0.201	0.196	0.192	0.187	0.183	0.179
16.0	0.198	0.193	0.188	0.183	0.179	0.174	0.170	0.167	0.163
16.5	0.180	0.176	0.171	0.167	0.163	0.159	0.156	0.152	0.149
17.0	0.165	0.161	0.157	0.153	0.149	0.146	0.143	0.140	0.137
17.5	0.152	0.148	0.144	0.140	0.137	0.134	0.131	0.128	0.126
18.0	0.140	0.136	0.133	0.130	0.127	0.124	0.121	0.118	0.116
18.5	0.129	0.126	0.123	0.120	0.117	0.114	0.112	0.110	0.108
19.0	0.120	0.116	0.114	0.111	0.109	0.106	0.104	0.102	0.100
19.5	0.111	0.108	0.106	0.103	0.101	0.099	0.097	0.095	0.093
20.0	0.103	0.101	0.098	0.096	0.094	0.092	0.090	0.088	0.087
20.5*	0.095	0.093	0.091	0.089	0.087	0.085	0.083	0.081	0.080
21.0*	0.087	0.085	0.083	0.081	0.079	0.078	0.076	0.074	0.073
21.5*	0.078	0.076	0.074	0.072	0.071	0.069	0.068	0.066	0.066
22.0*	0.068	0.066	0.064	0.063	0.062	0.060	0.059	0.058	0.057
22.5*	0.058	0.057	0.055	0.054	0.053	0.052	0.050	0.049	0.049
23.0*	0.053	0.052	0.050	0.049	0.048	0.047	0.046	0.045	0.044
23.5*	0.050	0.049	0.047	0.046	0.045	0.044	0.043	0.042	0.042
24.0*	0.047	0.046	0.044	0.043	0.043	0.042	0.041	0.040	0.039
24.5*	0.044	0.043	0.042	0.041	0.040	0.039	0.038	0.037	0.037
25.0*	0.041	0.040	0.039	0.038	0.037	0.036	0.036	0.035	0.034

* These values are based on a yield and load optimized operation that is not feasible at all sites.

Nordex N131/3900 IEC S – Thrust curves – Mode 1

for hub heights 84 m, 114 m, 120 m and 134 m								
wind speed v_H [m/s]	Thrust coefficients c_T at air density ρ [kg/m ³]							
	1.125	1.150	1.175	1.200	1.225	1.250	1.275	1.300
3.0	0.908	0.908	0.910	0.910	0.911	0.912	0.913	0.913
3.5	0.901	0.901	0.902	0.902	0.903	0.903	0.904	0.904
4.0	0.890	0.891	0.891	0.891	0.892	0.892	0.892	0.892
4.5	0.881	0.881	0.881	0.881	0.881	0.881	0.881	0.881
5.0	0.871	0.871	0.871	0.871	0.871	0.871	0.871	0.871
5.5	0.861	0.861	0.861	0.860	0.860	0.860	0.860	0.860
6.0	0.854	0.854	0.854	0.854	0.854	0.853	0.853	0.853
6.5	0.852	0.852	0.851	0.851	0.851	0.851	0.851	0.850
7.0	0.850	0.850	0.849	0.849	0.849	0.849	0.849	0.848
7.5	0.848	0.848	0.848	0.847	0.847	0.847	0.847	0.847
8.0	0.846	0.846	0.846	0.846	0.846	0.846	0.845	0.845
8.5	0.821	0.820	0.820	0.820	0.820	0.820	0.820	0.820
9.0	0.792	0.792	0.792	0.793	0.793	0.793	0.793	0.793
9.5	0.743	0.742	0.741	0.740	0.739	0.738	0.737	0.735
10.0	0.698	0.696	0.694	0.693	0.691	0.688	0.686	0.684
10.5	0.655	0.653	0.640	0.618	0.597	0.579	0.563	0.548
11.0	0.550	0.534	0.518	0.504	0.491	0.479	0.467	0.456
11.5	0.461	0.449	0.438	0.427	0.417	0.407	0.398	0.389
12.0	0.395	0.386	0.376	0.368	0.360	0.352	0.344	0.337
12.5	0.344	0.336	0.328	0.321	0.314	0.307	0.301	0.295
13.0	0.302	0.295	0.289	0.282	0.276	0.271	0.266	0.260
13.5	0.268	0.262	0.256	0.251	0.246	0.241	0.236	0.232
14.0	0.239	0.234	0.229	0.224	0.220	0.215	0.211	0.207
14.5	0.214	0.210	0.205	0.201	0.197	0.194	0.190	0.186
15.0	0.193	0.189	0.186	0.182	0.178	0.175	0.172	0.168
15.5	0.175	0.172	0.168	0.165	0.162	0.159	0.156	0.153
16.0	0.160	0.156	0.153	0.150	0.147	0.145	0.142	0.140
16.5	0.146	0.143	0.140	0.138	0.135	0.132	0.130	0.128
17.0	0.134	0.131	0.129	0.126	0.124	0.122	0.120	0.118
17.5	0.123	0.121	0.118	0.116	0.114	0.112	0.110	0.108
18.0	0.114	0.112	0.109	0.107	0.106	0.104	0.102	0.100
18.5	0.105	0.103	0.101	0.100	0.098	0.096	0.094	0.093
19.0	0.098	0.096	0.094	0.092	0.091	0.089	0.088	0.086
19.5	0.091	0.089	0.088	0.086	0.085	0.083	0.082	0.080
20.0	0.085	0.083	0.082	0.080	0.079	0.078	0.076	0.075
20.5*	0.079	0.077	0.076	0.074	0.073	0.072	0.070	0.069
21.0*	0.072	0.070	0.069	0.068	0.067	0.066	0.064	0.063
21.5*	0.064	0.062	0.062	0.060	0.059	0.059	0.057	0.056
22.0*	0.056	0.054	0.054	0.052	0.052	0.051	0.050	0.049
22.5*	0.048	0.046	0.046	0.045	0.044	0.044	0.043	0.042
23.0*	0.043	0.042	0.042	0.041	0.040	0.040	0.039	0.038
23.5*	0.041	0.040	0.040	0.039	0.038	0.038	0.037	0.036
24.0*	0.039	0.038	0.037	0.036	0.036	0.035	0.034	0.034
24.5*	0.036	0.035	0.035	0.034	0.033	0.033	0.032	0.032
25.0*	0.034	0.033	0.032	0.032	0.031	0.031	0.030	0.030

* These values are based on a yield and load optimized operation that is not feasible at all sites.

Nordex N131/3900 IEC S – Thrust curves – Mode 2

for hub heights 84 m, 114 m, 120 m and 134 m									
wind speed v_H [m/s]	Thrust coefficients c_T at air density ρ [kg/m ³]								
	0.900	0.925	0.950	0.975	1.000	1.025	1.050	1.075	1.100
3.0	0.902	0.902	0.902	0.902	0.903	0.904	0.905	0.906	0.907
3.5	0.894	0.895	0.896	0.897	0.898	0.898	0.899	0.900	0.900
4.0	0.887	0.888	0.888	0.888	0.889	0.889	0.889	0.890	0.890
4.5	0.880	0.880	0.880	0.880	0.880	0.880	0.880	0.880	0.881
5.0	0.872	0.872	0.872	0.872	0.872	0.872	0.872	0.872	0.872
5.5	0.864	0.863	0.863	0.863	0.862	0.862	0.862	0.862	0.862
6.0	0.858	0.857	0.857	0.857	0.856	0.856	0.856	0.855	0.855
6.5	0.855	0.854	0.854	0.854	0.853	0.853	0.853	0.853	0.852
7.0	0.852	0.852	0.852	0.851	0.851	0.851	0.851	0.850	0.850
7.5	0.850	0.850	0.850	0.850	0.849	0.849	0.849	0.849	0.848
8.0	0.847	0.847	0.847	0.847	0.847	0.847	0.847	0.847	0.847
8.5	0.821	0.821	0.821	0.821	0.821	0.821	0.821	0.821	0.820
9.0	0.784	0.784	0.784	0.784	0.784	0.784	0.784	0.783	0.783
9.5	0.742	0.742	0.741	0.741	0.740	0.740	0.739	0.738	0.738
10.0	0.702	0.701	0.700	0.699	0.699	0.698	0.697	0.696	0.695
10.5	0.664	0.663	0.662	0.661	0.660	0.659	0.658	0.656	0.655
11.0	0.628	0.628	0.626	0.625	0.624	0.608	0.585	0.564	0.546
11.5	0.595	0.580	0.557	0.536	0.518	0.501	0.485	0.471	0.458
12.0	0.502	0.484	0.468	0.453	0.439	0.426	0.414	0.403	0.392
12.5	0.429	0.415	0.403	0.391	0.380	0.369	0.359	0.350	0.341
13.0	0.374	0.362	0.351	0.342	0.332	0.323	0.315	0.307	0.300
13.5	0.329	0.319	0.310	0.301	0.293	0.286	0.279	0.272	0.266
14.0	0.292	0.283	0.275	0.268	0.261	0.255	0.248	0.243	0.237
14.5	0.260	0.253	0.246	0.240	0.234	0.228	0.223	0.218	0.213
15.0	0.234	0.228	0.222	0.216	0.211	0.206	0.201	0.196	0.192
15.5	0.212	0.206	0.201	0.196	0.191	0.186	0.182	0.178	0.174
16.0	0.192	0.187	0.182	0.178	0.174	0.169	0.166	0.162	0.158
16.5	0.175	0.171	0.166	0.162	0.158	0.155	0.151	0.148	0.145
17.0	0.160	0.156	0.152	0.149	0.145	0.142	0.139	0.136	0.133
17.5	0.147	0.144	0.140	0.137	0.133	0.130	0.128	0.125	0.122
18.0	0.136	0.132	0.129	0.126	0.123	0.120	0.118	0.115	0.113
18.5	0.125	0.122	0.119	0.116	0.114	0.111	0.109	0.107	0.105
19.0	0.116	0.113	0.111	0.108	0.106	0.103	0.101	0.099	0.097
19.5	0.108	0.105	0.103	0.100	0.098	0.096	0.094	0.092	0.090
20.0	0.101	0.098	0.096	0.094	0.092	0.090	0.088	0.086	0.084
20.5*	0.093	0.091	0.089	0.087	0.085	0.083	0.081	0.080	0.078
21.0*	0.085	0.083	0.081	0.079	0.078	0.076	0.074	0.073	0.071
21.5*	0.076	0.074	0.072	0.071	0.069	0.068	0.066	0.065	0.063
22.0*	0.066	0.064	0.063	0.062	0.060	0.059	0.058	0.056	0.055
22.5*	0.057	0.055	0.054	0.053	0.052	0.050	0.049	0.048	0.047
23.0*	0.052	0.050	0.049	0.048	0.047	0.046	0.045	0.044	0.043
23.5*	0.049	0.047	0.046	0.045	0.044	0.043	0.042	0.041	0.040
24.0*	0.046	0.044	0.043	0.043	0.042	0.041	0.040	0.039	0.038
24.5*	0.043	0.042	0.041	0.040	0.039	0.038	0.037	0.036	0.036
25.0*	0.040	0.039	0.038	0.037	0.036	0.036	0.035	0.034	0.033

* These values are based on a yield and load optimized operation that is not feasible at all sites.

Nordex N131/3900 IEC S – Thrust curves – Mode 2

for hub heights 84 m, 114 m, 120 m and 134 m								
wind speed v_H [m/s]	Thrust coefficients c_T at air density ρ [kg/m ³]							
	1.125	1.150	1.175	1.200	1.225	1.250	1.275	1.300
3.0	0.908	0.909	0.910	0.910	0.911	0.912	0.913	0.913
3.5	0.901	0.901	0.902	0.902	0.903	0.903	0.904	0.904
4.0	0.891	0.891	0.891	0.892	0.892	0.892	0.892	0.892
4.5	0.881	0.881	0.881	0.881	0.881	0.881	0.881	0.881
5.0	0.872	0.872	0.872	0.871	0.871	0.871	0.871	0.871
5.5	0.861	0.861	0.861	0.861	0.860	0.860	0.860	0.860
6.0	0.855	0.855	0.854	0.854	0.854	0.854	0.853	0.853
6.5	0.852	0.852	0.852	0.852	0.851	0.851	0.851	0.851
7.0	0.850	0.850	0.850	0.850	0.849	0.849	0.849	0.849
7.5	0.848	0.848	0.848	0.848	0.848	0.848	0.847	0.847
8.0	0.847	0.846	0.846	0.846	0.846	0.846	0.846	0.846
8.5	0.820	0.820	0.820	0.820	0.820	0.820	0.820	0.820
9.0	0.783	0.783	0.782	0.782	0.782	0.781	0.781	0.781
9.5	0.737	0.736	0.735	0.734	0.733	0.732	0.731	0.730
10.0	0.694	0.692	0.691	0.690	0.688	0.687	0.685	0.661
10.5	0.654	0.633	0.610	0.590	0.572	0.556	0.541	0.527
11.0	0.529	0.514	0.499	0.486	0.474	0.462	0.451	0.441
11.5	0.445	0.434	0.423	0.412	0.403	0.394	0.385	0.377
12.0	0.382	0.373	0.364	0.356	0.348	0.340	0.333	0.326
12.5	0.333	0.325	0.318	0.311	0.304	0.298	0.292	0.286
13.0	0.293	0.286	0.280	0.274	0.268	0.263	0.258	0.252
13.5	0.260	0.254	0.248	0.243	0.238	0.234	0.229	0.225
14.0	0.232	0.227	0.222	0.217	0.213	0.209	0.205	0.201
14.5	0.208	0.204	0.199	0.195	0.192	0.188	0.184	0.181
15.0	0.188	0.184	0.180	0.176	0.173	0.170	0.167	0.164
15.5	0.170	0.167	0.163	0.160	0.157	0.154	0.151	0.149
16.0	0.155	0.152	0.149	0.146	0.143	0.141	0.138	0.136
16.5	0.142	0.139	0.136	0.134	0.131	0.129	0.126	0.124
17.0	0.130	0.128	0.125	0.123	0.120	0.118	0.116	0.114
17.5	0.120	0.118	0.115	0.113	0.111	0.109	0.107	0.105
18.0	0.111	0.108	0.106	0.104	0.103	0.101	0.099	0.097
18.5	0.102	0.100	0.099	0.097	0.095	0.094	0.092	0.090
19.0	0.095	0.093	0.092	0.090	0.088	0.087	0.085	0.084
19.5	0.089	0.087	0.085	0.084	0.082	0.081	0.080	0.078
20.0	0.083	0.081	0.080	0.078	0.077	0.076	0.074	0.073
20.5*	0.077	0.075	0.074	0.072	0.071	0.070	0.068	0.068
21.0*	0.070	0.068	0.068	0.066	0.065	0.064	0.062	0.062
21.5*	0.062	0.061	0.060	0.059	0.058	0.057	0.056	0.055
22.0*	0.054	0.053	0.052	0.051	0.051	0.050	0.049	0.048
22.5*	0.046	0.045	0.045	0.044	0.043	0.043	0.041	0.041
23.0*	0.042	0.041	0.041	0.040	0.039	0.039	0.038	0.037
23.5*	0.040	0.039	0.039	0.038	0.037	0.037	0.036	0.035
24.0*	0.038	0.037	0.036	0.035	0.035	0.034	0.034	0.033
24.5*	0.035	0.034	0.034	0.033	0.033	0.032	0.031	0.031
25.0*	0.033	0.032	0.032	0.031	0.030	0.030	0.029	0.029

* These values are based on a yield and load optimized operation that is not feasible at all sites.

Nordex N131/3900 IEC S – Thrust curves – Mode 3

for hub heights 84 m, 114 m, 120 m and 134 m									
wind speed v_H [m/s]	Thrust coefficients c_T at air density ρ [kg/m ³]								
	0.900	0.925	0.950	0.975	1.000	1.025	1.050	1.075	1.100
3.0	0.902	0.902	0.902	0.902	0.903	0.904	0.905	0.906	0.907
3.5	0.894	0.895	0.896	0.897	0.898	0.898	0.899	0.900	0.900
4.0	0.887	0.888	0.888	0.889	0.889	0.889	0.890	0.890	0.890
4.5	0.880	0.880	0.880	0.880	0.880	0.881	0.881	0.881	0.881
5.0	0.873	0.873	0.872	0.872	0.872	0.872	0.872	0.872	0.872
5.5	0.864	0.864	0.863	0.863	0.863	0.863	0.862	0.862	0.862
6.0	0.858	0.858	0.858	0.857	0.857	0.856	0.856	0.856	0.856
6.5	0.855	0.855	0.854	0.854	0.854	0.854	0.853	0.853	0.853
7.0	0.853	0.852	0.852	0.852	0.852	0.851	0.851	0.851	0.851
7.5	0.851	0.850	0.850	0.850	0.850	0.850	0.849	0.849	0.849
8.0	0.848	0.848	0.848	0.848	0.848	0.847	0.847	0.847	0.847
8.5	0.829	0.829	0.828	0.828	0.828	0.828	0.828	0.828	0.828
9.0	0.789	0.789	0.788	0.788	0.788	0.788	0.787	0.787	0.787
9.5	0.745	0.745	0.744	0.744	0.743	0.742	0.742	0.741	0.740
10.0	0.704	0.703	0.702	0.702	0.701	0.700	0.699	0.698	0.696
10.5	0.665	0.664	0.663	0.662	0.661	0.660	0.659	0.657	0.649
11.0	0.629	0.628	0.627	0.626	0.602	0.578	0.558	0.539	0.522
11.5	0.577	0.553	0.532	0.513	0.496	0.480	0.466	0.452	0.440
12.0	0.482	0.465	0.450	0.436	0.422	0.410	0.399	0.388	0.378
12.5	0.413	0.400	0.388	0.377	0.366	0.356	0.347	0.338	0.329
13.0	0.360	0.349	0.339	0.330	0.321	0.312	0.304	0.297	0.290
13.5	0.317	0.308	0.299	0.291	0.284	0.276	0.270	0.263	0.257
14.0	0.282	0.274	0.266	0.259	0.253	0.246	0.240	0.235	0.229
14.5	0.252	0.245	0.238	0.232	0.226	0.221	0.216	0.211	0.206
15.0	0.227	0.220	0.215	0.209	0.204	0.199	0.195	0.190	0.186
15.5	0.205	0.200	0.194	0.190	0.185	0.180	0.176	0.172	0.169
16.0	0.186	0.181	0.177	0.172	0.168	0.164	0.160	0.157	0.154
16.5	0.170	0.165	0.161	0.157	0.154	0.150	0.147	0.144	0.140
17.0	0.156	0.152	0.148	0.144	0.141	0.138	0.134	0.132	0.129
17.5	0.143	0.139	0.136	0.132	0.130	0.127	0.124	0.121	0.119
18.0	0.132	0.128	0.125	0.122	0.120	0.117	0.114	0.112	0.110
18.5	0.122	0.119	0.116	0.113	0.110	0.108	0.106	0.104	0.102
19.0	0.113	0.110	0.107	0.105	0.103	0.100	0.098	0.096	0.094
19.5	0.105	0.102	0.100	0.098	0.095	0.093	0.091	0.090	0.088
20.0	0.098	0.095	0.093	0.091	0.089	0.087	0.085	0.084	0.082
20.5*	0.091	0.088	0.086	0.084	0.082	0.080	0.079	0.078	0.076
21.0*	0.083	0.080	0.078	0.077	0.075	0.073	0.072	0.071	0.069
21.5*	0.074	0.072	0.070	0.069	0.067	0.066	0.064	0.063	0.062
22.0*	0.064	0.062	0.061	0.060	0.058	0.057	0.056	0.055	0.054
22.5*	0.055	0.053	0.052	0.051	0.050	0.049	0.048	0.047	0.046
23.0*	0.050	0.049	0.048	0.047	0.045	0.044	0.043	0.043	0.042
23.5*	0.047	0.046	0.045	0.044	0.043	0.042	0.041	0.040	0.040
24.0*	0.044	0.043	0.042	0.041	0.040	0.039	0.039	0.038	0.037
24.5*	0.042	0.040	0.039	0.039	0.038	0.037	0.036	0.036	0.035
25.0*	0.039	0.038	0.037	0.036	0.035	0.034	0.034	0.033	0.032

* These values are based on a yield and load optimized operation that is not feasible at all sites.

Nordex N131/3900 IEC S – Thrust curves – Mode 3

for hub heights 84 m, 114 m, 120 m and 134 m								
wind speed v_H [m/s]	Thrust coefficients c_T at air density ρ [kg/m ³]							
	1.125	1.150	1.175	1.200	1.225	1.250	1.275	1.300
3.0	0.908	0.909	0.909	0.910	0.911	0.912	0.913	0.913
3.5	0.901	0.901	0.902	0.902	0.903	0.903	0.904	0.904
4.0	0.891	0.891	0.891	0.892	0.892	0.892	0.892	0.893
4.5	0.881	0.881	0.881	0.881	0.881	0.882	0.882	0.882
5.0	0.872	0.872	0.872	0.872	0.872	0.872	0.872	0.872
5.5	0.862	0.861	0.861	0.861	0.861	0.861	0.861	0.860
6.0	0.855	0.855	0.855	0.854	0.854	0.854	0.854	0.854
6.5	0.853	0.852	0.852	0.852	0.852	0.852	0.851	0.851
7.0	0.851	0.850	0.850	0.850	0.850	0.850	0.850	0.849
7.5	0.849	0.849	0.848	0.848	0.848	0.848	0.848	0.848
8.0	0.847	0.847	0.847	0.847	0.847	0.846	0.846	0.846
8.5	0.828	0.828	0.828	0.828	0.828	0.827	0.827	0.827
9.0	0.786	0.786	0.786	0.785	0.785	0.784	0.784	0.783
9.5	0.739	0.738	0.738	0.736	0.735	0.734	0.733	0.732
10.0	0.695	0.694	0.693	0.691	0.690	0.671	0.646	0.625
10.5	0.623	0.601	0.581	0.563	0.547	0.532	0.518	0.505
11.0	0.507	0.492	0.479	0.467	0.455	0.444	0.434	0.424
11.5	0.428	0.417	0.407	0.397	0.388	0.379	0.371	0.363
12.0	0.369	0.360	0.352	0.344	0.336	0.329	0.322	0.315
12.5	0.322	0.314	0.307	0.300	0.294	0.288	0.282	0.276
13.0	0.283	0.277	0.271	0.265	0.259	0.254	0.249	0.244
13.5	0.251	0.246	0.240	0.235	0.231	0.226	0.222	0.218
14.0	0.224	0.220	0.215	0.210	0.206	0.202	0.198	0.195
14.5	0.202	0.197	0.193	0.189	0.186	0.182	0.179	0.175
15.0	0.182	0.178	0.175	0.171	0.168	0.165	0.162	0.159
15.5	0.165	0.162	0.158	0.155	0.152	0.150	0.147	0.144
16.0	0.150	0.147	0.144	0.142	0.139	0.136	0.134	0.132
16.5	0.138	0.135	0.132	0.130	0.127	0.125	0.123	0.121
17.0	0.126	0.124	0.121	0.119	0.117	0.115	0.113	0.111
17.5	0.116	0.114	0.112	0.110	0.108	0.106	0.104	0.102
18.0	0.107	0.105	0.103	0.102	0.100	0.098	0.096	0.095
18.5	0.100	0.098	0.096	0.094	0.092	0.091	0.089	0.088
19.0	0.092	0.091	0.089	0.087	0.086	0.084	0.083	0.082
19.5	0.086	0.084	0.083	0.082	0.080	0.079	0.077	0.076
20.0	0.080	0.079	0.078	0.076	0.075	0.074	0.072	0.071
20.5*	0.074	0.073	0.072	0.070	0.069	0.068	0.067	0.066
21.0*	0.068	0.067	0.066	0.064	0.063	0.062	0.061	0.060
21.5*	0.060	0.059	0.059	0.057	0.056	0.056	0.054	0.053
22.0*	0.052	0.052	0.051	0.050	0.049	0.049	0.047	0.047
22.5*	0.045	0.044	0.044	0.043	0.042	0.041	0.040	0.040
23.0*	0.041	0.040	0.040	0.039	0.038	0.038	0.037	0.036
23.5*	0.039	0.038	0.038	0.037	0.036	0.036	0.035	0.034
24.0*	0.036	0.036	0.035	0.034	0.034	0.034	0.033	0.032
24.5*	0.034	0.033	0.033	0.032	0.032	0.031	0.031	0.030
25.0*	0.032	0.031	0.031	0.030	0.030	0.029	0.028	0.028

* These values are based on a yield and load optimized operation that is not feasible at all sites.

Nordex N131/3900 IEC S – Thrust curves – Mode 4

for hub heights 84 m, 114 m, 120 m and 134 m									
wind speed v_H [m/s]	Thrust coefficients c_T at air density ρ [kg/m ³]								
	0.900	0.925	0.950	0.975	1.000	1.025	1.050	1.075	1.100
3.0	0.902	0.902	0.902	0.902	0.903	0.904	0.905	0.906	0.907
3.5	0.894	0.895	0.896	0.897	0.898	0.898	0.899	0.900	0.900
4.0	0.887	0.888	0.888	0.889	0.889	0.890	0.890	0.890	0.891
4.5	0.880	0.880	0.880	0.880	0.881	0.881	0.881	0.881	0.881
5.0	0.873	0.873	0.873	0.873	0.873	0.872	0.872	0.872	0.872
5.5	0.864	0.864	0.864	0.864	0.863	0.863	0.863	0.862	0.862
6.0	0.859	0.858	0.858	0.858	0.857	0.857	0.856	0.856	0.856
6.5	0.856	0.855	0.855	0.855	0.854	0.854	0.854	0.854	0.853
7.0	0.853	0.853	0.853	0.852	0.852	0.852	0.852	0.851	0.851
7.5	0.851	0.851	0.851	0.850	0.850	0.850	0.850	0.850	0.850
8.0	0.848	0.848	0.848	0.848	0.848	0.848	0.848	0.847	0.847
8.5	0.824	0.824	0.824	0.824	0.824	0.824	0.824	0.824	0.824
9.0	0.779	0.779	0.778	0.778	0.778	0.778	0.777	0.777	0.777
9.5	0.736	0.736	0.735	0.735	0.734	0.734	0.733	0.733	0.732
10.0	0.696	0.695	0.695	0.694	0.693	0.693	0.692	0.691	0.690
10.5	0.658	0.657	0.656	0.656	0.655	0.654	0.653	0.642	0.616
11.0	0.621	0.621	0.620	0.599	0.575	0.554	0.535	0.518	0.502
11.5	0.552	0.531	0.511	0.493	0.477	0.462	0.449	0.436	0.424
12.0	0.464	0.448	0.434	0.420	0.408	0.396	0.385	0.375	0.366
12.5	0.399	0.386	0.375	0.364	0.354	0.344	0.335	0.327	0.319
13.0	0.348	0.338	0.328	0.319	0.310	0.302	0.295	0.287	0.281
13.5	0.307	0.298	0.290	0.282	0.275	0.268	0.261	0.255	0.249
14.0	0.273	0.265	0.258	0.251	0.245	0.239	0.233	0.228	0.222
14.5	0.244	0.238	0.231	0.225	0.220	0.214	0.209	0.204	0.200
15.0	0.220	0.214	0.208	0.203	0.198	0.193	0.189	0.184	0.180
15.5	0.199	0.194	0.188	0.184	0.179	0.175	0.171	0.167	0.164
16.0	0.181	0.176	0.171	0.167	0.163	0.159	0.156	0.152	0.149
16.5	0.165	0.160	0.156	0.153	0.149	0.146	0.142	0.139	0.136
17.0	0.151	0.147	0.143	0.140	0.137	0.134	0.131	0.128	0.125
17.5	0.139	0.135	0.132	0.129	0.126	0.123	0.120	0.118	0.115
18.0	0.128	0.125	0.122	0.119	0.116	0.114	0.111	0.109	0.106
18.5	0.118	0.115	0.112	0.110	0.107	0.105	0.103	0.101	0.099
19.0	0.110	0.107	0.104	0.102	0.100	0.098	0.096	0.094	0.092
19.5	0.102	0.099	0.097	0.095	0.093	0.091	0.089	0.087	0.085
20.0	0.095	0.093	0.090	0.088	0.086	0.085	0.083	0.081	0.080
20.5*	0.088	0.086	0.083	0.081	0.080	0.079	0.077	0.075	0.074
21.0*	0.080	0.078	0.076	0.074	0.073	0.072	0.070	0.068	0.068
21.5*	0.072	0.070	0.068	0.066	0.065	0.064	0.062	0.061	0.060
22.0*	0.062	0.061	0.059	0.058	0.056	0.056	0.054	0.053	0.052
22.5*	0.053	0.052	0.050	0.049	0.048	0.048	0.046	0.045	0.045
23.0*	0.049	0.048	0.046	0.045	0.044	0.043	0.042	0.041	0.041
23.5*	0.046	0.045	0.043	0.042	0.041	0.041	0.040	0.039	0.039
24.0*	0.043	0.042	0.041	0.040	0.039	0.039	0.038	0.037	0.036
24.5*	0.040	0.039	0.038	0.037	0.036	0.036	0.035	0.034	0.034
25.0*	0.038	0.037	0.036	0.035	0.034	0.034	0.033	0.032	0.032

* These values are based on a yield and load optimized operation that is not feasible at all sites.

Nordex N131/3900 IEC S – Thrust curves – Mode 4

for hub heights 84 m, 114 m, 120 m and 134 m								
wind speed v_H [m/s]	Thrust coefficients c_T at air density ρ [kg/m ³]							
	1.125	1.150	1.175	1.200	1.225	1.250	1.275	1.300
3.0	0.908	0.909	0.909	0.910	0.911	0.912	0.912	0.913
3.5	0.901	0.902	0.902	0.902	0.903	0.903	0.904	0.904
4.0	0.891	0.891	0.892	0.892	0.892	0.892	0.893	0.893
4.5	0.881	0.881	0.882	0.882	0.882	0.882	0.882	0.882
5.0	0.872	0.872	0.872	0.872	0.872	0.872	0.872	0.872
5.5	0.862	0.862	0.862	0.861	0.861	0.861	0.861	0.861
6.0	0.856	0.855	0.855	0.855	0.855	0.854	0.854	0.854
6.5	0.853	0.853	0.853	0.852	0.852	0.852	0.852	0.852
7.0	0.851	0.851	0.851	0.850	0.850	0.850	0.850	0.850
7.5	0.849	0.849	0.849	0.849	0.849	0.849	0.848	0.848
8.0	0.847	0.847	0.847	0.847	0.847	0.847	0.847	0.847
8.5	0.824	0.824	0.824	0.824	0.824	0.824	0.824	0.824
9.0	0.776	0.776	0.776	0.775	0.774	0.774	0.773	0.773
9.5	0.731	0.731	0.730	0.729	0.728	0.727	0.726	0.725
10.0	0.690	0.688	0.688	0.686	0.659	0.635	0.614	0.596
10.5	0.594	0.574	0.556	0.540	0.525	0.511	0.498	0.486
11.0	0.488	0.474	0.462	0.450	0.439	0.428	0.419	0.409
11.5	0.413	0.403	0.393	0.384	0.375	0.367	0.359	0.351
12.0	0.356	0.348	0.340	0.332	0.325	0.318	0.311	0.305
12.5	0.311	0.304	0.297	0.291	0.284	0.279	0.273	0.268
13.0	0.274	0.268	0.262	0.256	0.251	0.246	0.241	0.237
13.5	0.243	0.238	0.233	0.228	0.224	0.219	0.215	0.211
14.0	0.218	0.213	0.208	0.204	0.200	0.196	0.192	0.189
14.5	0.195	0.191	0.187	0.184	0.180	0.177	0.173	0.170
15.0	0.177	0.173	0.169	0.166	0.163	0.160	0.157	0.154
15.5	0.160	0.157	0.154	0.151	0.148	0.145	0.143	0.140
16.0	0.146	0.143	0.140	0.138	0.135	0.132	0.130	0.128
16.5	0.134	0.131	0.128	0.126	0.124	0.121	0.119	0.117
17.0	0.123	0.120	0.118	0.116	0.114	0.112	0.110	0.108
17.5	0.113	0.111	0.109	0.107	0.105	0.103	0.101	0.099
18.0	0.104	0.102	0.100	0.099	0.097	0.095	0.094	0.092
18.5	0.097	0.095	0.093	0.091	0.090	0.088	0.087	0.085
19.0	0.090	0.088	0.087	0.085	0.084	0.082	0.081	0.079
19.5	0.084	0.082	0.081	0.079	0.078	0.077	0.075	0.074
20.0	0.078	0.077	0.075	0.074	0.073	0.072	0.070	0.069
20.5*	0.072	0.071	0.069	0.068	0.068	0.067	0.065	0.064
21.0*	0.066	0.065	0.063	0.062	0.062	0.061	0.059	0.058
21.5*	0.059	0.058	0.056	0.056	0.055	0.054	0.053	0.052
22.0*	0.051	0.051	0.049	0.049	0.048	0.047	0.046	0.045
22.5*	0.044	0.043	0.042	0.041	0.041	0.040	0.039	0.039
23.0*	0.040	0.039	0.038	0.038	0.037	0.037	0.036	0.035
23.5*	0.038	0.037	0.036	0.036	0.035	0.035	0.034	0.033
24.0*	0.035	0.035	0.034	0.034	0.033	0.033	0.032	0.031
24.5*	0.033	0.033	0.032	0.031	0.031	0.031	0.030	0.029
25.0*	0.031	0.030	0.030	0.029	0.029	0.028	0.028	0.027

* These values are based on a yield and load optimized operation that is not feasible at all sites.

Nordex N131/3900 IEC S – Thrust curves – Mode 5

for hub heights 84 m, 114 m, 120 m and 134 m									
wind speed v_H [m/s]	Thrust coefficients c_T at air density ρ [kg/m ³]								
	0.900	0.925	0.950	0.975	1.000	1.025	1.050	1.075	1.100
3.0	0.902	0.902	0.902	0.902	0.903	0.904	0.905	0.906	0.907
3.5	0.894	0.895	0.896	0.897	0.898	0.898	0.899	0.900	0.900
4.0	0.888	0.888	0.888	0.889	0.889	0.890	0.890	0.890	0.891
4.5	0.880	0.880	0.881	0.881	0.881	0.881	0.881	0.881	0.881
5.0	0.873	0.873	0.873	0.873	0.873	0.873	0.873	0.873	0.873
5.5	0.865	0.864	0.864	0.864	0.864	0.863	0.863	0.863	0.863
6.0	0.859	0.859	0.858	0.858	0.858	0.857	0.857	0.857	0.856
6.5	0.856	0.856	0.855	0.855	0.855	0.854	0.854	0.854	0.854
7.0	0.854	0.853	0.853	0.853	0.853	0.852	0.852	0.852	0.852
7.5	0.852	0.852	0.851	0.851	0.851	0.851	0.850	0.850	0.850
8.0	0.849	0.849	0.849	0.848	0.848	0.848	0.848	0.848	0.848
8.5	0.819	0.819	0.819	0.819	0.819	0.819	0.818	0.818	0.818
9.0	0.775	0.774	0.774	0.774	0.774	0.774	0.774	0.773	0.773
9.5	0.732	0.732	0.732	0.732	0.731	0.731	0.730	0.730	0.730
10.0	0.692	0.692	0.692	0.691	0.691	0.690	0.690	0.689	0.689
10.5	0.654	0.653	0.653	0.652	0.652	0.652	0.635	0.609	0.587
11.0	0.617	0.617	0.596	0.571	0.550	0.530	0.513	0.497	0.482
11.5	0.529	0.509	0.491	0.474	0.459	0.445	0.432	0.420	0.409
12.0	0.447	0.432	0.418	0.405	0.393	0.382	0.372	0.362	0.353
12.5	0.385	0.373	0.362	0.352	0.342	0.333	0.324	0.316	0.308
13.0	0.336	0.326	0.317	0.308	0.300	0.292	0.285	0.278	0.272
13.5	0.297	0.288	0.280	0.273	0.266	0.259	0.253	0.247	0.241
14.0	0.264	0.257	0.250	0.243	0.237	0.231	0.226	0.220	0.215
14.5	0.236	0.230	0.224	0.218	0.213	0.208	0.203	0.198	0.194
15.0	0.213	0.207	0.202	0.197	0.192	0.187	0.183	0.179	0.175
15.5	0.193	0.188	0.183	0.178	0.174	0.170	0.166	0.162	0.159
16.0	0.175	0.171	0.166	0.162	0.158	0.155	0.151	0.148	0.145
16.5	0.160	0.156	0.152	0.148	0.145	0.141	0.138	0.135	0.132
17.0	0.146	0.143	0.139	0.136	0.133	0.130	0.127	0.124	0.122
17.5	0.135	0.131	0.128	0.125	0.122	0.119	0.117	0.114	0.112
18.0	0.124	0.121	0.118	0.115	0.113	0.110	0.108	0.106	0.103
18.5	0.115	0.112	0.109	0.107	0.104	0.102	0.100	0.098	0.096
19.0	0.106	0.104	0.101	0.099	0.097	0.095	0.093	0.091	0.089
19.5	0.099	0.097	0.094	0.092	0.090	0.088	0.086	0.085	0.083
20.0	0.092	0.090	0.088	0.086	0.084	0.082	0.081	0.079	0.078
20.5*	0.085	0.083	0.081	0.080	0.078	0.076	0.075	0.073	0.072
21.0*	0.078	0.076	0.074	0.073	0.071	0.069	0.068	0.067	0.066
21.5*	0.069	0.068	0.066	0.065	0.063	0.062	0.061	0.059	0.059
22.0*	0.060	0.059	0.058	0.056	0.055	0.054	0.053	0.052	0.051
22.5*	0.052	0.050	0.049	0.048	0.047	0.046	0.045	0.044	0.044
23.0*	0.047	0.046	0.045	0.044	0.043	0.042	0.041	0.040	0.040
23.5*	0.044	0.043	0.042	0.041	0.040	0.040	0.039	0.038	0.038
24.0*	0.042	0.041	0.040	0.039	0.038	0.037	0.037	0.036	0.035
24.5*	0.039	0.038	0.037	0.036	0.036	0.035	0.034	0.033	0.033
25.0*	0.036	0.036	0.035	0.034	0.033	0.032	0.032	0.031	0.031

* These values are based on a yield and load optimized operation that is not feasible at all sites.

Nordex N131/3900 IEC S – Thrust curves – Mode 5

for hub heights 84 m, 114 m, 120 m and 134 m								
wind speed v_H [m/s]	Thrust coefficients c_T at air density ρ [kg/m ³]							
	1.125	1.150	1.175	1.200	1.225	1.250	1.275	1.300
3.0	0.908	0.909	0.910	0.910	0.911	0.912	0.912	0.913
3.5	0.901	0.902	0.902	0.903	0.903	0.904	0.904	0.904
4.0	0.891	0.892	0.892	0.892	0.892	0.892	0.893	0.893
4.5	0.882	0.882	0.882	0.882	0.882	0.882	0.882	0.882
5.0	0.872	0.872	0.872	0.872	0.872	0.872	0.872	0.872
5.5	0.862	0.862	0.862	0.862	0.862	0.861	0.861	0.861
6.0	0.856	0.856	0.856	0.855	0.855	0.855	0.855	0.854
6.5	0.854	0.853	0.853	0.853	0.853	0.853	0.852	0.852
7.0	0.852	0.851	0.851	0.851	0.851	0.851	0.851	0.850
7.5	0.850	0.850	0.850	0.850	0.849	0.849	0.849	0.849
8.0	0.848	0.848	0.848	0.848	0.848	0.847	0.847	0.847
8.5	0.818	0.818	0.818	0.818	0.818	0.818	0.818	0.818
9.0	0.773	0.772	0.772	0.772	0.771	0.771	0.770	0.770
9.5	0.729	0.729	0.728	0.728	0.727	0.726	0.726	0.726
10.0	0.689	0.689	0.676	0.648	0.625	0.604	0.586	0.569
10.5	0.567	0.549	0.533	0.518	0.504	0.491	0.478	0.467
11.0	0.469	0.456	0.444	0.433	0.423	0.413	0.404	0.395
11.5	0.399	0.389	0.379	0.370	0.362	0.354	0.346	0.339
12.0	0.344	0.336	0.328	0.321	0.314	0.307	0.301	0.295
12.5	0.301	0.294	0.287	0.281	0.275	0.270	0.264	0.259
13.0	0.265	0.259	0.254	0.248	0.243	0.238	0.234	0.229
13.5	0.236	0.230	0.226	0.221	0.216	0.212	0.208	0.204
14.0	0.211	0.206	0.202	0.198	0.194	0.190	0.186	0.183
14.5	0.189	0.186	0.182	0.178	0.174	0.171	0.168	0.165
15.0	0.171	0.168	0.164	0.161	0.158	0.155	0.152	0.149
15.5	0.155	0.152	0.149	0.146	0.144	0.141	0.138	0.136
16.0	0.142	0.139	0.136	0.134	0.131	0.129	0.126	0.124
16.5	0.130	0.127	0.125	0.122	0.120	0.118	0.116	0.114
17.0	0.119	0.117	0.114	0.112	0.110	0.108	0.106	0.105
17.5	0.110	0.108	0.106	0.104	0.102	0.100	0.098	0.096
18.0	0.101	0.099	0.098	0.096	0.094	0.092	0.091	0.089
18.5	0.094	0.092	0.090	0.089	0.087	0.086	0.084	0.083
19.0	0.087	0.086	0.084	0.083	0.081	0.080	0.078	0.077
19.5	0.081	0.080	0.078	0.077	0.076	0.074	0.073	0.072
20.0	0.076	0.075	0.073	0.072	0.071	0.070	0.068	0.067
20.5*	0.070	0.069	0.068	0.067	0.066	0.065	0.063	0.062
21.0*	0.064	0.063	0.062	0.061	0.060	0.059	0.057	0.057
21.5*	0.057	0.056	0.055	0.054	0.053	0.053	0.051	0.050
22.0*	0.050	0.049	0.048	0.047	0.047	0.046	0.045	0.044
22.5*	0.043	0.042	0.041	0.040	0.040	0.039	0.038	0.038
23.0*	0.039	0.038	0.037	0.037	0.036	0.036	0.035	0.034
23.5*	0.037	0.036	0.035	0.035	0.034	0.034	0.033	0.032
24.0*	0.034	0.034	0.033	0.033	0.032	0.032	0.031	0.030
24.5*	0.032	0.032	0.031	0.031	0.030	0.030	0.029	0.028
25.0*	0.030	0.030	0.029	0.028	0.028	0.028	0.027	0.026

* These values are based on a yield and load optimized operation that is not feasible at all sites.

Nordex N131/3900 IEC S – Thrust curves – Mode 6

for hub heights 84 m, 114 m and 134 m (mode not available for 120 m)									
wind speed v_H [m/s]	Thrust coefficients c_T at air density ρ [kg/m ³]								
	0.900	0.925	0.950	0.975	1.000	1.025	1.050	1.075	1.100
3.0	0.902	0.902	0.902	0.902	0.903	0.904	0.905	0.906	0.907
3.5	0.895	0.896	0.896	0.897	0.898	0.899	0.900	0.900	0.901
4.0	0.888	0.888	0.889	0.890	0.890	0.890	0.891	0.891	0.891
4.5	0.881	0.881	0.881	0.882	0.882	0.882	0.882	0.882	0.882
5.0	0.874	0.874	0.874	0.874	0.874	0.874	0.874	0.874	0.874
5.5	0.866	0.866	0.865	0.865	0.865	0.864	0.864	0.864	0.864
6.0	0.860	0.860	0.860	0.859	0.859	0.859	0.858	0.858	0.858
6.5	0.857	0.857	0.857	0.856	0.856	0.856	0.856	0.856	0.855
7.0	0.855	0.855	0.854	0.854	0.854	0.854	0.854	0.854	0.853
7.5	0.822	0.822	0.823	0.823	0.824	0.824	0.824	0.825	0.825
8.0	0.763	0.764	0.765	0.766	0.767	0.768	0.769	0.771	0.772
8.5	0.708	0.709	0.711	0.713	0.714	0.716	0.718	0.720	0.722
9.0	0.658	0.659	0.662	0.664	0.666	0.668	0.670	0.673	0.676
9.5	0.612	0.613	0.617	0.618	0.621	0.623	0.626	0.628	0.631
10.0	0.570	0.572	0.575	0.577	0.579	0.582	0.584	0.587	0.590
10.5	0.532	0.533	0.537	0.539	0.541	0.544	0.547	0.540	0.521
11.0	0.496	0.498	0.502	0.504	0.492	0.475	0.460	0.446	0.433
11.5	0.465	0.461	0.442	0.427	0.414	0.401	0.390	0.379	0.369
12.0	0.404	0.390	0.378	0.366	0.355	0.346	0.336	0.328	0.319
12.5	0.349	0.338	0.328	0.318	0.310	0.301	0.294	0.286	0.279
13.0	0.305	0.296	0.288	0.280	0.272	0.265	0.259	0.252	0.247
13.5	0.270	0.262	0.255	0.248	0.242	0.236	0.230	0.224	0.219
14.0	0.240	0.234	0.227	0.221	0.216	0.210	0.205	0.201	0.196
14.5	0.215	0.210	0.204	0.199	0.194	0.189	0.185	0.180	0.176
15.0	0.194	0.189	0.184	0.179	0.175	0.171	0.167	0.163	0.160
15.5	0.176	0.171	0.167	0.163	0.159	0.155	0.151	0.148	0.145
16.0	0.160	0.156	0.152	0.148	0.144	0.141	0.138	0.135	0.132
16.5	0.146	0.142	0.139	0.135	0.132	0.129	0.126	0.124	0.121
17.0	0.134	0.130	0.127	0.124	0.121	0.118	0.116	0.113	0.111
17.5	0.123	0.120	0.117	0.114	0.112	0.109	0.107	0.104	0.102
18.0	0.114	0.111	0.108	0.106	0.103	0.101	0.099	0.096	0.095
18.5	0.105	0.102	0.100	0.098	0.095	0.093	0.091	0.089	0.088
19.0	0.097	0.095	0.093	0.091	0.089	0.087	0.085	0.083	0.082
19.5	0.091	0.088	0.086	0.084	0.082	0.081	0.079	0.077	0.076
20.0	0.084	0.082	0.080	0.079	0.077	0.075	0.074	0.072	0.071
20.5*	0.078	0.076	0.074	0.073	0.071	0.069	0.068	0.067	0.066
21.0*	0.071	0.069	0.068	0.067	0.065	0.063	0.062	0.061	0.060
21.5*	0.063	0.062	0.060	0.059	0.058	0.056	0.056	0.054	0.053
22.0*	0.055	0.054	0.052	0.052	0.051	0.049	0.049	0.047	0.047
22.5*	0.047	0.046	0.045	0.044	0.043	0.042	0.041	0.040	0.040
23.0*	0.043	0.042	0.041	0.040	0.039	0.038	0.038	0.037	0.036
23.5*	0.040	0.040	0.039	0.038	0.037	0.036	0.036	0.035	0.034
24.0*	0.038	0.037	0.036	0.036	0.035	0.034	0.034	0.033	0.032
24.5*	0.036	0.035	0.034	0.033	0.033	0.032	0.031	0.031	0.030
25.0*	0.033	0.032	0.032	0.031	0.030	0.030	0.029	0.028	0.028

* These values are based on a yield and load optimized operation that is not feasible at all sites.

Nordex N131/3900 IEC S – Thrust curves – Mode 6

for hub heights 84 m, 114 m and 134 m (mode not available for 120 m)								
wind speed v_H [m/s]	Thrust coefficients c_T at air density ρ [kg/m ³]							
	1.125	1.150	1.175	1.200	1.225	1.250	1.275	1.300
3.0	0.908	0.909	0.909	0.910	0.911	0.912	0.913	0.913
3.5	0.901	0.902	0.902	0.903	0.903	0.904	0.904	0.905
4.0	0.892	0.892	0.892	0.893	0.893	0.893	0.893	0.894
4.5	0.882	0.882	0.883	0.883	0.883	0.883	0.883	0.883
5.0	0.874	0.873	0.873	0.873	0.873	0.873	0.873	0.873
5.5	0.864	0.863	0.863	0.863	0.863	0.863	0.862	0.862
6.0	0.858	0.857	0.857	0.857	0.857	0.856	0.856	0.856
6.5	0.855	0.855	0.855	0.854	0.854	0.854	0.854	0.854
7.0	0.853	0.853	0.853	0.853	0.852	0.852	0.852	0.852
7.5	0.826	0.826	0.827	0.827	0.827	0.827	0.827	0.827
8.0	0.774	0.775	0.776	0.777	0.778	0.778	0.778	0.778
8.5	0.725	0.726	0.729	0.730	0.732	0.732	0.732	0.731
9.0	0.678	0.680	0.683	0.685	0.687	0.687	0.687	0.687
9.5	0.635	0.636	0.640	0.642	0.644	0.644	0.644	0.639
10.0	0.594	0.596	0.587	0.566	0.548	0.532	0.518	0.504
10.5	0.504	0.489	0.475	0.462	0.450	0.439	0.428	0.418
11.0	0.421	0.410	0.399	0.390	0.380	0.372	0.363	0.356
11.5	0.360	0.351	0.342	0.334	0.327	0.320	0.313	0.307
12.0	0.312	0.304	0.297	0.291	0.284	0.278	0.273	0.267
12.5	0.273	0.267	0.261	0.255	0.250	0.245	0.240	0.235
13.0	0.241	0.236	0.230	0.226	0.221	0.216	0.212	0.208
13.5	0.214	0.210	0.205	0.201	0.197	0.193	0.189	0.186
14.0	0.192	0.188	0.184	0.180	0.176	0.173	0.170	0.167
14.5	0.173	0.169	0.166	0.162	0.159	0.156	0.153	0.150
15.0	0.156	0.153	0.150	0.147	0.144	0.141	0.139	0.136
15.5	0.142	0.139	0.136	0.133	0.131	0.128	0.126	0.124
16.0	0.129	0.127	0.124	0.122	0.120	0.117	0.115	0.113
16.5	0.118	0.116	0.114	0.112	0.110	0.108	0.106	0.104
17.0	0.109	0.107	0.105	0.103	0.101	0.099	0.097	0.096
17.5	0.100	0.098	0.096	0.095	0.093	0.091	0.090	0.088
18.0	0.093	0.091	0.089	0.088	0.086	0.084	0.083	0.082
18.5	0.086	0.084	0.083	0.081	0.080	0.078	0.077	0.076
19.0	0.080	0.078	0.077	0.076	0.074	0.073	0.072	0.070
19.5	0.074	0.073	0.072	0.070	0.069	0.068	0.067	0.066
20.0	0.070	0.068	0.067	0.066	0.065	0.064	0.063	0.062
20.5*	0.065	0.063	0.062	0.061	0.060	0.059	0.058	0.057
21.0*	0.059	0.057	0.057	0.056	0.055	0.054	0.053	0.052
21.5*	0.053	0.051	0.050	0.050	0.049	0.048	0.047	0.047
22.0*	0.046	0.045	0.044	0.043	0.043	0.042	0.041	0.041
22.5*	0.039	0.038	0.038	0.037	0.036	0.036	0.035	0.035
23.0*	0.036	0.035	0.034	0.034	0.033	0.033	0.032	0.032
23.5*	0.034	0.033	0.032	0.032	0.031	0.031	0.030	0.030
24.0*	0.032	0.031	0.030	0.030	0.029	0.029	0.029	0.028
24.5*	0.030	0.029	0.028	0.028	0.028	0.027	0.027	0.026
25.0*	0.028	0.027	0.026	0.026	0.026	0.025	0.025	0.024

* These values are based on a yield and load optimized operation that is not feasible at all sites.

Nordex N131/3900 IEC S – Thrust curves – Mode 7

for hub heights 84 m, 114 m and 134 m (mode not available for 120 m)									
wind speed v_H [m/s]	Thrust coefficients c_T at air density ρ [kg/m ³]								
	0.900	0.925	0.950	0.975	1.000	1.025	1.050	1.075	1.100
3.0	0.902	0.902	0.902	0.902	0.903	0.904	0.905	0.906	0.907
3.5	0.895	0.896	0.897	0.897	0.898	0.899	0.900	0.900	0.901
4.0	0.888	0.889	0.889	0.890	0.890	0.890	0.891	0.891	0.892
4.5	0.881	0.882	0.882	0.882	0.882	0.882	0.882	0.882	0.882
5.0	0.875	0.874	0.874	0.874	0.874	0.874	0.874	0.874	0.874
5.5	0.866	0.866	0.866	0.865	0.865	0.865	0.865	0.864	0.864
6.0	0.861	0.860	0.860	0.860	0.859	0.859	0.859	0.858	0.858
6.5	0.858	0.857	0.857	0.857	0.857	0.856	0.856	0.856	0.856
7.0	0.856	0.855	0.855	0.855	0.854	0.854	0.854	0.854	0.854
7.5	0.804	0.804	0.805	0.806	0.807	0.807	0.808	0.809	0.810
8.0	0.741	0.742	0.744	0.746	0.747	0.748	0.751	0.752	0.755
8.5	0.684	0.686	0.688	0.690	0.693	0.694	0.698	0.699	0.703
9.0	0.633	0.635	0.638	0.640	0.643	0.645	0.649	0.651	0.655
9.5	0.587	0.589	0.592	0.594	0.599	0.602	0.607	0.610	0.615
10.0	0.547	0.552	0.556	0.560	0.564	0.567	0.570	0.573	0.576
10.5	0.516	0.520	0.523	0.526	0.529	0.531	0.534	0.524	0.505
11.0	0.485	0.488	0.490	0.492	0.479	0.461	0.446	0.433	0.421
11.5	0.454	0.452	0.430	0.415	0.402	0.390	0.379	0.369	0.359
12.0	0.394	0.380	0.368	0.356	0.346	0.336	0.328	0.319	0.311
12.5	0.340	0.329	0.319	0.310	0.302	0.294	0.286	0.279	0.272
13.0	0.298	0.289	0.280	0.273	0.266	0.259	0.252	0.246	0.240
13.5	0.263	0.256	0.249	0.242	0.236	0.230	0.224	0.219	0.214
14.0	0.234	0.228	0.222	0.216	0.210	0.205	0.200	0.196	0.191
14.5	0.210	0.204	0.199	0.194	0.189	0.184	0.180	0.176	0.172
15.0	0.190	0.184	0.180	0.175	0.171	0.167	0.163	0.159	0.156
15.5	0.172	0.167	0.163	0.159	0.155	0.151	0.148	0.144	0.141
16.0	0.156	0.152	0.148	0.144	0.141	0.138	0.135	0.132	0.129
16.5	0.143	0.139	0.135	0.132	0.129	0.126	0.123	0.121	0.118
17.0	0.131	0.127	0.124	0.121	0.118	0.116	0.113	0.111	0.108
17.5	0.120	0.117	0.114	0.112	0.109	0.107	0.104	0.102	0.100
18.0	0.111	0.108	0.106	0.103	0.101	0.098	0.096	0.094	0.092
18.5	0.103	0.100	0.098	0.095	0.093	0.091	0.089	0.087	0.086
19.0	0.095	0.093	0.091	0.089	0.087	0.085	0.083	0.081	0.080
19.5	0.088	0.086	0.084	0.082	0.081	0.079	0.077	0.076	0.074
20.0	0.083	0.081	0.079	0.077	0.075	0.074	0.072	0.071	0.069
20.5*	0.077	0.075	0.073	0.071	0.069	0.068	0.067	0.066	0.064
21.0*	0.070	0.068	0.067	0.065	0.063	0.062	0.061	0.060	0.058
21.5*	0.062	0.061	0.059	0.058	0.056	0.056	0.054	0.053	0.052
22.0*	0.054	0.053	0.052	0.051	0.049	0.049	0.047	0.047	0.045
22.5*	0.046	0.045	0.044	0.043	0.042	0.041	0.040	0.040	0.039
23.0*	0.042	0.041	0.040	0.039	0.038	0.038	0.037	0.036	0.035
23.5*	0.040	0.039	0.038	0.037	0.036	0.036	0.035	0.034	0.033
24.0*	0.038	0.037	0.036	0.035	0.034	0.034	0.033	0.032	0.031
24.5*	0.035	0.034	0.033	0.033	0.032	0.031	0.031	0.030	0.029
25.0*	0.033	0.032	0.031	0.030	0.030	0.029	0.028	0.028	0.027

* These values are based on a yield and load optimized operation that is not feasible at all sites.

Nordex N131/3900 IEC S – Thrust curves – Mode 7

for hub heights 84 m, 114 m and 134 m (mode not available for 120 m)								
wind speed v_H [m/s]	Thrust coefficients c_T at air density ρ [kg/m ³]							
	1.125	1.150	1.175	1.200	1.225	1.250	1.275	1.300
3.0	0.908	0.909	0.910	0.910	0.911	0.912	0.913	0.913
3.5	0.902	0.902	0.903	0.903	0.903	0.904	0.904	0.905
4.0	0.892	0.892	0.892	0.893	0.893	0.893	0.894	0.894
4.5	0.883	0.883	0.883	0.883	0.883	0.883	0.883	0.883
5.0	0.874	0.874	0.874	0.874	0.874	0.874	0.874	0.873
5.5	0.864	0.864	0.863	0.863	0.863	0.863	0.863	0.863
6.0	0.858	0.858	0.857	0.857	0.857	0.857	0.857	0.856
6.5	0.856	0.855	0.855	0.855	0.855	0.854	0.854	0.854
7.0	0.854	0.853	0.853	0.853	0.853	0.853	0.853	0.853
7.5	0.811	0.812	0.813	0.814	0.814	0.815	0.815	0.815
8.0	0.756	0.758	0.760	0.761	0.763	0.764	0.764	0.764
8.5	0.705	0.708	0.711	0.712	0.715	0.717	0.717	0.716
9.0	0.658	0.662	0.665	0.667	0.670	0.672	0.672	0.672
9.5	0.618	0.621	0.624	0.625	0.628	0.629	0.629	0.614
10.0	0.579	0.581	0.567	0.548	0.531	0.516	0.502	0.489
10.5	0.489	0.474	0.461	0.449	0.437	0.426	0.416	0.407
11.0	0.409	0.399	0.388	0.379	0.370	0.362	0.354	0.346
11.5	0.350	0.341	0.333	0.326	0.318	0.312	0.305	0.299
12.0	0.304	0.296	0.290	0.283	0.277	0.271	0.266	0.260
12.5	0.266	0.260	0.254	0.249	0.244	0.238	0.234	0.229
13.0	0.235	0.230	0.225	0.220	0.216	0.211	0.207	0.203
13.5	0.209	0.204	0.200	0.196	0.192	0.188	0.185	0.181
14.0	0.187	0.183	0.179	0.176	0.172	0.169	0.166	0.163
14.5	0.168	0.165	0.162	0.158	0.155	0.152	0.149	0.147
15.0	0.152	0.149	0.146	0.143	0.141	0.138	0.135	0.133
15.5	0.138	0.136	0.133	0.130	0.128	0.126	0.123	0.121
16.0	0.126	0.124	0.121	0.119	0.117	0.115	0.112	0.111
16.5	0.116	0.113	0.111	0.109	0.107	0.105	0.103	0.101
17.0	0.106	0.104	0.102	0.100	0.098	0.097	0.095	0.093
17.5	0.098	0.096	0.094	0.092	0.091	0.089	0.088	0.086
18.0	0.091	0.089	0.087	0.086	0.084	0.082	0.081	0.080
18.5	0.084	0.082	0.081	0.079	0.078	0.077	0.075	0.074
19.0	0.078	0.077	0.075	0.074	0.072	0.071	0.070	0.069
19.5	0.073	0.071	0.070	0.069	0.068	0.066	0.065	0.064
20.0	0.068	0.067	0.066	0.064	0.063	0.062	0.061	0.060
20.5*	0.063	0.062	0.061	0.059	0.058	0.057	0.056	0.056
21.0*	0.057	0.057	0.056	0.054	0.053	0.052	0.051	0.051
21.5*	0.051	0.050	0.050	0.048	0.047	0.047	0.046	0.045
22.0*	0.045	0.044	0.043	0.042	0.041	0.041	0.040	0.039
22.5*	0.038	0.038	0.037	0.036	0.035	0.035	0.034	0.034
23.0*	0.035	0.034	0.034	0.033	0.032	0.032	0.031	0.031
23.5*	0.033	0.032	0.032	0.031	0.030	0.030	0.029	0.029
24.0*	0.031	0.030	0.030	0.029	0.029	0.028	0.028	0.027
24.5*	0.029	0.028	0.028	0.027	0.027	0.026	0.026	0.025
25.0*	0.027	0.026	0.026	0.025	0.025	0.024	0.024	0.024

* These values are based on a yield and load optimized operation that is not feasible at all sites.

Nordex N131/3900 IEC S – Thrust curves – Mode 8

for hub heights 84 m, 114 m, 120 m and 134 m									
wind speed v_H [m/s]	Thrust coefficients c_T at air density ρ [kg/m ³]								
	0.900	0.925	0.950	0.975	1.000	1.025	1.050	1.075	1.100
3.0	0.902	0.902	0.902	0.902	0.903	0.904	0.905	0.906	0.907
3.5	0.895	0.896	0.897	0.898	0.898	0.899	0.900	0.900	0.901
4.0	0.889	0.889	0.890	0.890	0.890	0.891	0.891	0.892	0.892
4.5	0.882	0.882	0.882	0.882	0.883	0.883	0.883	0.883	0.883
5.0	0.875	0.875	0.875	0.875	0.875	0.875	0.875	0.874	0.874
5.5	0.867	0.867	0.866	0.866	0.866	0.866	0.865	0.865	0.865
6.0	0.862	0.861	0.861	0.860	0.860	0.860	0.860	0.859	0.859
6.5	0.859	0.858	0.858	0.858	0.858	0.857	0.857	0.857	0.857
7.0	0.849	0.849	0.850	0.850	0.850	0.850	0.850	0.850	0.850
7.5	0.781	0.781	0.782	0.783	0.784	0.786	0.787	0.788	0.789
8.0	0.718	0.718	0.720	0.722	0.724	0.726	0.728	0.730	0.731
8.5	0.662	0.662	0.664	0.666	0.669	0.672	0.675	0.677	0.679
9.0	0.611	0.612	0.614	0.616	0.619	0.622	0.626	0.628	0.630
9.5	0.565	0.566	0.569	0.571	0.574	0.578	0.581	0.584	0.586
10.0	0.524	0.525	0.528	0.530	0.534	0.537	0.540	0.543	0.545
10.5	0.487	0.488	0.490	0.493	0.496	0.499	0.503	0.489	0.473
11.0	0.453	0.454	0.456	0.459	0.449	0.434	0.420	0.408	0.397
11.5	0.422	0.421	0.405	0.392	0.380	0.369	0.358	0.349	0.340
12.0	0.371	0.359	0.348	0.337	0.328	0.319	0.310	0.302	0.295
12.5	0.322	0.312	0.303	0.294	0.286	0.279	0.272	0.265	0.259
13.0	0.282	0.274	0.266	0.259	0.252	0.246	0.240	0.234	0.229
13.5	0.250	0.243	0.236	0.230	0.224	0.218	0.213	0.208	0.204
14.0	0.223	0.217	0.211	0.206	0.200	0.195	0.191	0.186	0.182
14.5	0.200	0.195	0.190	0.185	0.180	0.176	0.172	0.168	0.164
15.0	0.180	0.176	0.171	0.167	0.163	0.159	0.155	0.152	0.148
15.5	0.164	0.159	0.155	0.151	0.148	0.144	0.141	0.138	0.135
16.0	0.149	0.145	0.141	0.138	0.135	0.132	0.129	0.126	0.123
16.5	0.136	0.132	0.129	0.126	0.123	0.120	0.118	0.115	0.113
17.0	0.125	0.122	0.119	0.116	0.113	0.110	0.108	0.106	0.104
17.5	0.115	0.112	0.109	0.107	0.104	0.102	0.100	0.098	0.096
18.0	0.106	0.103	0.101	0.098	0.096	0.094	0.092	0.090	0.088
18.5	0.098	0.096	0.093	0.091	0.089	0.087	0.085	0.084	0.082
19.0	0.091	0.089	0.087	0.085	0.083	0.081	0.079	0.078	0.076
19.5	0.085	0.083	0.081	0.079	0.077	0.076	0.074	0.072	0.071
20.0	0.079	0.077	0.075	0.074	0.072	0.070	0.069	0.068	0.066
20.5*	0.073	0.071	0.069	0.068	0.067	0.065	0.064	0.063	0.061
21.0*	0.067	0.065	0.063	0.062	0.061	0.059	0.058	0.057	0.056
21.5*	0.059	0.058	0.056	0.056	0.054	0.053	0.052	0.051	0.050
22.0*	0.052	0.051	0.049	0.049	0.047	0.046	0.045	0.045	0.043
22.5*	0.044	0.043	0.042	0.041	0.040	0.039	0.039	0.038	0.037
23.0*	0.040	0.039	0.038	0.038	0.037	0.036	0.035	0.035	0.034
23.5*	0.038	0.037	0.036	0.036	0.035	0.034	0.033	0.033	0.032
24.0*	0.036	0.035	0.034	0.034	0.033	0.032	0.031	0.031	0.030
24.5*	0.033	0.033	0.032	0.031	0.031	0.030	0.029	0.029	0.028
25.0*	0.031	0.030	0.030	0.029	0.028	0.028	0.027	0.027	0.026

* These values are based on a yield and load optimized operation that is not feasible at all sites.

Nordex N131/3900 IEC S – Thrust curves – Mode 8

for hub heights 84 m, 114 m, 120 m and 134 m								
wind speed v_H [m/s]	Thrust coefficients c_T at air density ρ [kg/m ³]							
	1.125	1.150	1.175	1.200	1.225	1.250	1.275	1.300
3.0	0.908	0.909	0.910	0.910	0.911	0.912	0.913	0.914
3.5	0.902	0.902	0.903	0.903	0.904	0.904	0.905	0.905
4.0	0.892	0.893	0.893	0.893	0.893	0.894	0.894	0.894
4.5	0.883	0.883	0.883	0.883	0.884	0.884	0.884	0.884
5.0	0.874	0.874	0.874	0.874	0.874	0.874	0.874	0.874
5.5	0.865	0.864	0.864	0.864	0.864	0.864	0.863	0.863
6.0	0.859	0.859	0.858	0.858	0.858	0.858	0.858	0.857
6.5	0.856	0.856	0.856	0.856	0.856	0.856	0.855	0.855
7.0	0.850	0.851	0.851	0.851	0.851	0.851	0.851	0.851
7.5	0.790	0.792	0.792	0.793	0.794	0.795	0.796	0.798
8.0	0.733	0.736	0.737	0.739	0.740	0.743	0.744	0.747
8.5	0.681	0.685	0.686	0.689	0.690	0.694	0.695	0.699
9.0	0.633	0.637	0.638	0.642	0.643	0.647	0.648	0.653
9.5	0.588	0.593	0.594	0.598	0.599	0.603	0.586	0.568
10.0	0.548	0.546	0.527	0.511	0.496	0.483	0.471	0.459
10.5	0.459	0.446	0.434	0.423	0.412	0.402	0.393	0.384
11.0	0.386	0.376	0.367	0.358	0.350	0.342	0.335	0.328
11.5	0.331	0.323	0.316	0.309	0.302	0.295	0.289	0.283
12.0	0.288	0.281	0.275	0.269	0.263	0.258	0.252	0.248
12.5	0.253	0.247	0.242	0.236	0.231	0.227	0.222	0.218
13.0	0.224	0.218	0.214	0.209	0.205	0.201	0.197	0.193
13.5	0.199	0.195	0.191	0.187	0.183	0.179	0.176	0.173
14.0	0.178	0.174	0.171	0.167	0.164	0.161	0.158	0.155
14.5	0.160	0.157	0.154	0.151	0.148	0.145	0.142	0.140
15.0	0.145	0.142	0.139	0.137	0.134	0.132	0.129	0.127
15.5	0.132	0.129	0.127	0.124	0.122	0.120	0.118	0.116
16.0	0.121	0.118	0.116	0.114	0.112	0.109	0.108	0.106
16.5	0.110	0.108	0.106	0.104	0.102	0.100	0.099	0.097
17.0	0.102	0.100	0.098	0.096	0.094	0.092	0.091	0.089
17.5	0.094	0.092	0.090	0.088	0.087	0.085	0.084	0.082
18.0	0.087	0.085	0.083	0.082	0.080	0.079	0.078	0.076
18.5	0.080	0.079	0.077	0.076	0.075	0.073	0.072	0.071
19.0	0.075	0.073	0.072	0.071	0.069	0.068	0.067	0.066
19.5	0.070	0.068	0.067	0.066	0.065	0.064	0.063	0.062
20.0	0.065	0.064	0.063	0.062	0.061	0.060	0.059	0.058
20.5*	0.060	0.059	0.058	0.057	0.056	0.056	0.055	0.054
21.0*	0.055	0.054	0.053	0.052	0.051	0.051	0.050	0.049
21.5*	0.049	0.048	0.047	0.047	0.046	0.045	0.044	0.044
22.0*	0.043	0.042	0.041	0.041	0.040	0.039	0.039	0.038
22.5*	0.036	0.036	0.035	0.035	0.034	0.034	0.033	0.032
23.0*	0.033	0.033	0.032	0.032	0.031	0.031	0.030	0.030
23.5*	0.031	0.031	0.030	0.030	0.029	0.029	0.028	0.028
24.0*	0.029	0.029	0.029	0.028	0.028	0.027	0.027	0.026
24.5*	0.028	0.027	0.027	0.026	0.026	0.025	0.025	0.025
25.0*	0.026	0.025	0.025	0.024	0.024	0.024	0.023	0.023

* These values are based on a yield and load optimized operation that is not feasible at all sites.

Nordex N131/3900 IEC S – Thrust curves – Mode 9

for hub heights 84 m, 114 m and 120 m (mode not available for 134 m)									
wind speed v_H [m/s]	Thrust coefficients c_T at air density ρ [kg/m ³]								
	0.900	0.925	0.950	0.975	1.000	1.025	1.050	1.075	1.100
3.0	0.902	0.902	0.902	0.902	0.903	0.904	0.905	0.906	0.907
3.5	0.895	0.896	0.897	0.898	0.898	0.899	0.900	0.901	0.901
4.0	0.889	0.889	0.890	0.890	0.891	0.891	0.891	0.892	0.892
4.5	0.882	0.882	0.882	0.882	0.883	0.883	0.883	0.883	0.883
5.0	0.876	0.875	0.875	0.875	0.875	0.875	0.875	0.875	0.875
5.5	0.867	0.867	0.867	0.866	0.866	0.866	0.866	0.865	0.865
6.0	0.862	0.862	0.861	0.861	0.861	0.860	0.860	0.860	0.860
6.5	0.859	0.859	0.858	0.858	0.858	0.858	0.858	0.857	0.857
7.0	0.825	0.826	0.826	0.827	0.827	0.827	0.828	0.828	0.829
7.5	0.756	0.756	0.758	0.759	0.760	0.761	0.763	0.764	0.764
8.0	0.692	0.694	0.696	0.698	0.700	0.701	0.703	0.704	0.706
8.5	0.636	0.638	0.641	0.643	0.645	0.646	0.649	0.650	0.652
9.0	0.586	0.588	0.591	0.593	0.596	0.597	0.600	0.602	0.604
9.5	0.541	0.543	0.546	0.549	0.552	0.553	0.556	0.558	0.560
10.0	0.501	0.503	0.506	0.509	0.511	0.513	0.516	0.518	0.520
10.5	0.465	0.467	0.470	0.472	0.475	0.476	0.481	0.477	0.461
11.0	0.432	0.434	0.437	0.441	0.439	0.423	0.410	0.398	0.387
11.5	0.403	0.407	0.396	0.382	0.371	0.360	0.350	0.340	0.332
12.0	0.363	0.350	0.339	0.329	0.320	0.311	0.303	0.295	0.288
12.5	0.314	0.305	0.296	0.287	0.280	0.272	0.265	0.259	0.253
13.0	0.276	0.268	0.260	0.253	0.246	0.240	0.234	0.229	0.224
13.5	0.244	0.237	0.231	0.225	0.219	0.214	0.208	0.204	0.199
14.0	0.218	0.212	0.206	0.201	0.196	0.191	0.187	0.182	0.178
14.5	0.196	0.190	0.185	0.181	0.176	0.172	0.168	0.164	0.160
15.0	0.176	0.172	0.167	0.163	0.159	0.155	0.152	0.148	0.145
15.5	0.160	0.156	0.152	0.148	0.144	0.141	0.138	0.135	0.132
16.0	0.146	0.142	0.138	0.135	0.132	0.129	0.126	0.123	0.120
16.5	0.133	0.130	0.126	0.123	0.120	0.118	0.115	0.113	0.110
17.0	0.122	0.119	0.116	0.113	0.111	0.108	0.106	0.104	0.101
17.5	0.112	0.110	0.107	0.104	0.102	0.100	0.098	0.096	0.094
18.0	0.104	0.101	0.099	0.096	0.094	0.092	0.090	0.088	0.086
18.5	0.096	0.094	0.091	0.089	0.087	0.085	0.084	0.082	0.080
19.0	0.089	0.087	0.085	0.083	0.081	0.079	0.078	0.076	0.075
19.5	0.083	0.081	0.079	0.077	0.076	0.074	0.072	0.071	0.070
20.0	0.077	0.076	0.074	0.072	0.070	0.069	0.068	0.066	0.065
20.5*	0.071	0.070	0.068	0.067	0.065	0.064	0.063	0.061	0.060
21.0*	0.065	0.064	0.062	0.061	0.059	0.058	0.057	0.056	0.055
21.5*	0.058	0.057	0.056	0.054	0.053	0.052	0.051	0.050	0.049
22.0*	0.051	0.050	0.049	0.047	0.046	0.045	0.045	0.043	0.043
22.5*	0.043	0.043	0.041	0.040	0.039	0.039	0.038	0.037	0.036
23.0*	0.039	0.039	0.038	0.037	0.036	0.035	0.035	0.034	0.033
23.5*	0.037	0.037	0.036	0.035	0.034	0.033	0.033	0.032	0.031
24.0*	0.035	0.034	0.034	0.033	0.032	0.031	0.031	0.030	0.029
24.5*	0.033	0.032	0.031	0.031	0.030	0.029	0.029	0.028	0.028
25.0*	0.030	0.030	0.029	0.028	0.028	0.027	0.027	0.026	0.026

* These values are based on a yield and load optimized operation that is not feasible at all sites.

Nordex N131/3900 IEC S – Thrust curves – Mode 9

for hub heights 84 m, 114 m and 120 m (mode not available for 134 m)								
wind speed v_H [m/s]	Thrust coefficients c_T at air density ρ [kg/m ³]							
	1.125	1.150	1.175	1.200	1.225	1.250	1.275	1.300
3.0	0.908	0.908	0.910	0.911	0.911	0.912	0.913	0.914
3.5	0.902	0.902	0.903	0.903	0.904	0.904	0.905	0.905
4.0	0.892	0.893	0.893	0.893	0.894	0.894	0.894	0.894
4.5	0.883	0.883	0.884	0.884	0.884	0.884	0.884	0.884
5.0	0.875	0.875	0.874	0.874	0.874	0.875	0.874	0.875
5.5	0.865	0.865	0.864	0.864	0.864	0.864	0.864	0.864
6.0	0.859	0.859	0.859	0.858	0.858	0.858	0.858	0.858
6.5	0.857	0.857	0.856	0.856	0.856	0.856	0.856	0.856
7.0	0.829	0.829	0.830	0.831	0.832	0.832	0.832	0.833
7.5	0.766	0.767	0.769	0.771	0.774	0.774	0.776	0.777
8.0	0.707	0.709	0.712	0.716	0.720	0.721	0.723	0.725
8.5	0.654	0.656	0.660	0.664	0.669	0.670	0.674	0.675
9.0	0.606	0.608	0.612	0.617	0.622	0.623	0.627	0.629
9.5	0.562	0.564	0.569	0.573	0.579	0.581	0.569	0.551
10.0	0.522	0.526	0.513	0.497	0.483	0.470	0.458	0.447
10.5	0.447	0.434	0.423	0.412	0.402	0.392	0.383	0.375
11.0	0.377	0.367	0.358	0.350	0.342	0.334	0.327	0.320
11.5	0.324	0.316	0.308	0.301	0.295	0.288	0.282	0.277
12.0	0.281	0.275	0.269	0.263	0.257	0.252	0.247	0.242
12.5	0.247	0.241	0.236	0.231	0.226	0.222	0.217	0.213
13.0	0.218	0.214	0.209	0.205	0.200	0.196	0.193	0.189
13.5	0.194	0.190	0.186	0.182	0.179	0.175	0.172	0.169
14.0	0.174	0.171	0.167	0.164	0.160	0.157	0.154	0.152
14.5	0.157	0.154	0.151	0.148	0.145	0.142	0.139	0.137
15.0	0.142	0.139	0.136	0.134	0.131	0.129	0.126	0.124
15.5	0.129	0.127	0.124	0.122	0.119	0.117	0.115	0.113
16.0	0.118	0.116	0.113	0.111	0.109	0.107	0.105	0.103
16.5	0.108	0.106	0.104	0.102	0.100	0.098	0.096	0.095
17.0	0.099	0.097	0.096	0.094	0.092	0.090	0.089	0.087
17.5	0.092	0.090	0.088	0.086	0.085	0.084	0.082	0.081
18.0	0.085	0.083	0.082	0.080	0.079	0.077	0.076	0.075
18.5	0.079	0.077	0.076	0.074	0.073	0.072	0.071	0.069
19.0	0.073	0.072	0.070	0.069	0.068	0.067	0.066	0.065
19.5	0.068	0.067	0.066	0.064	0.063	0.062	0.061	0.060
20.0	0.064	0.062	0.061	0.060	0.059	0.058	0.057	0.056
20.5*	0.059	0.057	0.056	0.056	0.055	0.054	0.053	0.052
21.0*	0.054	0.052	0.051	0.051	0.050	0.049	0.048	0.047
21.5*	0.048	0.047	0.046	0.045	0.044	0.044	0.043	0.042
22.0*	0.042	0.041	0.040	0.039	0.039	0.038	0.037	0.037
22.5*	0.036	0.035	0.034	0.034	0.033	0.032	0.032	0.031
23.0*	0.033	0.032	0.031	0.031	0.030	0.030	0.029	0.029
23.5*	0.031	0.030	0.029	0.029	0.028	0.028	0.027	0.027
24.0*	0.029	0.028	0.028	0.027	0.027	0.026	0.026	0.025
24.5*	0.027	0.026	0.026	0.025	0.025	0.025	0.024	0.024
25.0*	0.025	0.024	0.024	0.024	0.023	0.023	0.023	0.022

* These values are based on a yield and load optimized operation that is not feasible at all sites.

Nordex N131/3900 IEC S – Thrust curves – Mode 10

for hub heights 84 m, 114 m and 120 m (mode not available for 134 m)									
wind speed v_H [m/s]	Thrust coefficients c_T at air density ρ [kg/m ³]								
	0.900	0.925	0.950	0.975	1.000	1.025	1.050	1.075	1.100
3.0	0.902	0.902	0.902	0.902	0.903	0.904	0.905	0.906	0.907
3.5	0.895	0.896	0.897	0.898	0.899	0.899	0.900	0.901	0.901
4.0	0.889	0.890	0.890	0.890	0.891	0.891	0.892	0.892	0.892
4.5	0.882	0.882	0.882	0.883	0.883	0.883	0.883	0.883	0.884
5.0	0.876	0.876	0.876	0.875	0.875	0.875	0.875	0.875	0.875
5.5	0.868	0.867	0.867	0.867	0.866	0.866	0.866	0.866	0.866
6.0	0.862	0.862	0.862	0.861	0.861	0.861	0.860	0.860	0.860
6.5	0.860	0.859	0.859	0.859	0.858	0.858	0.858	0.858	0.858
7.0	0.800	0.801	0.802	0.803	0.803	0.804	0.804	0.805	0.805
7.5	0.731	0.733	0.734	0.735	0.736	0.737	0.738	0.739	0.740
8.0	0.669	0.671	0.673	0.674	0.675	0.676	0.678	0.680	0.681
8.5	0.613	0.616	0.618	0.619	0.621	0.622	0.625	0.626	0.628
9.0	0.564	0.567	0.570	0.571	0.573	0.574	0.576	0.578	0.581
9.5	0.520	0.523	0.526	0.529	0.533	0.536	0.540	0.543	0.546
10.0	0.485	0.490	0.495	0.498	0.501	0.503	0.506	0.508	0.510
10.5	0.457	0.461	0.464	0.466	0.468	0.470	0.472	0.467	0.449
11.0	0.429	0.431	0.434	0.435	0.433	0.413	0.400	0.388	0.377
11.5	0.402	0.404	0.389	0.374	0.362	0.351	0.341	0.332	0.324
12.0	0.357	0.343	0.332	0.322	0.312	0.304	0.296	0.288	0.281
12.5	0.307	0.298	0.289	0.281	0.273	0.266	0.259	0.253	0.247
13.0	0.270	0.262	0.254	0.247	0.241	0.235	0.229	0.224	0.218
13.5	0.239	0.232	0.226	0.220	0.214	0.209	0.204	0.199	0.194
14.0	0.213	0.207	0.202	0.196	0.191	0.187	0.182	0.178	0.174
14.5	0.191	0.186	0.181	0.176	0.172	0.168	0.164	0.160	0.157
15.0	0.173	0.168	0.164	0.160	0.156	0.152	0.148	0.145	0.142
15.5	0.156	0.152	0.148	0.145	0.141	0.138	0.135	0.132	0.129
16.0	0.142	0.139	0.135	0.132	0.129	0.126	0.123	0.120	0.118
16.5	0.130	0.127	0.124	0.121	0.118	0.115	0.113	0.110	0.108
17.0	0.119	0.116	0.114	0.111	0.108	0.106	0.104	0.101	0.099
17.5	0.110	0.107	0.104	0.102	0.100	0.098	0.095	0.093	0.092
18.0	0.102	0.099	0.097	0.094	0.092	0.090	0.088	0.086	0.085
18.5	0.094	0.092	0.089	0.087	0.085	0.084	0.082	0.080	0.078
19.0	0.087	0.085	0.083	0.081	0.079	0.078	0.076	0.074	0.073
19.5	0.081	0.079	0.077	0.076	0.074	0.072	0.071	0.069	0.068
20.0	0.076	0.074	0.072	0.070	0.069	0.068	0.066	0.065	0.064
20.5*	0.070	0.068	0.067	0.065	0.064	0.063	0.061	0.060	0.059
21.0*	0.064	0.062	0.061	0.059	0.058	0.057	0.056	0.055	0.054
21.5*	0.057	0.056	0.054	0.053	0.052	0.051	0.050	0.049	0.048
22.0*	0.050	0.049	0.047	0.046	0.045	0.045	0.043	0.043	0.042
22.5*	0.043	0.041	0.040	0.039	0.039	0.038	0.037	0.036	0.036
23.0*	0.039	0.038	0.037	0.036	0.035	0.035	0.034	0.033	0.033
23.5*	0.037	0.036	0.035	0.034	0.033	0.033	0.032	0.031	0.031
24.0*	0.034	0.034	0.033	0.032	0.031	0.031	0.030	0.029	0.029
24.5*	0.032	0.031	0.031	0.030	0.029	0.029	0.028	0.028	0.027
25.0*	0.030	0.029	0.028	0.028	0.027	0.027	0.026	0.026	0.025

* These values are based on a yield and load optimized operation that is not feasible at all sites.

Nordex N131/3900 IEC S – Thrust curves – Mode 10

for hub heights 84 m, 114 m and 120 m (mode not available for 134 m)								
wind speed v_H [m/s]	Thrust coefficients c_T at air density ρ [kg/m ³]							
	1.125	1.150	1.175	1.200	1.225	1.250	1.275	1.300
3.0	0.908	0.909	0.910	0.911	0.911	0.912	0.913	0.914
3.5	0.902	0.902	0.903	0.904	0.904	0.904	0.905	0.905
4.0	0.893	0.893	0.893	0.894	0.894	0.894	0.894	0.894
4.5	0.884	0.884	0.884	0.884	0.884	0.884	0.884	0.884
5.0	0.875	0.875	0.875	0.875	0.875	0.875	0.875	0.875
5.5	0.865	0.865	0.865	0.865	0.864	0.864	0.864	0.864
6.0	0.860	0.859	0.859	0.859	0.859	0.859	0.858	0.858
6.5	0.857	0.857	0.857	0.857	0.857	0.856	0.856	0.856
7.0	0.806	0.807	0.808	0.809	0.810	0.811	0.811	0.812
7.5	0.741	0.743	0.745	0.747	0.750	0.751	0.752	0.754
8.0	0.682	0.685	0.688	0.690	0.694	0.696	0.697	0.700
8.5	0.629	0.632	0.636	0.638	0.643	0.646	0.648	0.651
9.0	0.584	0.589	0.594	0.597	0.601	0.604	0.606	0.608
9.5	0.548	0.552	0.556	0.558	0.561	0.564	0.552	0.535
10.0	0.512	0.515	0.499	0.484	0.470	0.458	0.446	0.435
10.5	0.436	0.423	0.412	0.401	0.392	0.382	0.374	0.365
11.0	0.367	0.358	0.349	0.341	0.333	0.326	0.319	0.312
11.5	0.316	0.308	0.301	0.294	0.288	0.282	0.276	0.270
12.0	0.275	0.268	0.262	0.256	0.251	0.246	0.241	0.236
12.5	0.241	0.236	0.231	0.226	0.221	0.216	0.212	0.208
13.0	0.213	0.209	0.204	0.200	0.196	0.192	0.188	0.185
13.5	0.190	0.186	0.182	0.178	0.175	0.171	0.168	0.165
14.0	0.170	0.167	0.163	0.160	0.157	0.154	0.151	0.148
14.5	0.154	0.150	0.147	0.144	0.142	0.139	0.136	0.134
15.0	0.139	0.136	0.133	0.131	0.128	0.126	0.124	0.121
15.5	0.126	0.124	0.121	0.119	0.117	0.115	0.113	0.111
16.0	0.115	0.113	0.111	0.109	0.107	0.105	0.103	0.101
16.5	0.106	0.104	0.102	0.100	0.098	0.096	0.094	0.093
17.0	0.097	0.095	0.094	0.092	0.090	0.088	0.087	0.085
17.5	0.090	0.088	0.086	0.085	0.083	0.082	0.080	0.079
18.0	0.083	0.081	0.080	0.078	0.077	0.076	0.074	0.073
18.5	0.077	0.076	0.074	0.073	0.072	0.070	0.069	0.068
19.0	0.072	0.070	0.069	0.068	0.066	0.065	0.064	0.063
19.5	0.067	0.066	0.064	0.063	0.062	0.061	0.060	0.059
20.0	0.062	0.061	0.060	0.059	0.058	0.057	0.056	0.055
20.5*	0.057	0.056	0.056	0.055	0.054	0.053	0.052	0.051
21.0*	0.052	0.051	0.051	0.050	0.049	0.048	0.047	0.046
21.5*	0.047	0.046	0.045	0.044	0.044	0.043	0.042	0.041
22.0*	0.041	0.040	0.039	0.039	0.038	0.037	0.037	0.036
22.5*	0.035	0.034	0.034	0.033	0.032	0.032	0.031	0.031
23.0*	0.032	0.031	0.031	0.030	0.030	0.029	0.029	0.028
23.5*	0.030	0.029	0.029	0.028	0.028	0.027	0.027	0.027
24.0*	0.028	0.028	0.027	0.027	0.026	0.026	0.025	0.025
24.5*	0.026	0.026	0.025	0.025	0.025	0.024	0.024	0.023
25.0*	0.024	0.024	0.024	0.023	0.023	0.023	0.022	0.022

* These values are based on a yield and load optimized operation that is not feasible at all sites.

Nordex N131/3900 IEC S – Thrust curves – Mode 11

for hub heights 84 m, 114 m and 120 m (mode not available for 134 m)									
wind speed v_H [m/s]	Thrust coefficients c_T at air density ρ [kg/m ³]								
	0.900	0.925	0.950	0.975	1.000	1.025	1.050	1.075	1.100
3.0	0.902	0.902	0.902	0.902	0.903	0.904	0.905	0.906	0.907
3.5	0.895	0.896	0.897	0.898	0.899	0.899	0.900	0.901	0.901
4.0	0.889	0.890	0.890	0.891	0.891	0.891	0.892	0.892	0.892
4.5	0.883	0.883	0.883	0.883	0.883	0.883	0.884	0.884	0.884
5.0	0.876	0.876	0.876	0.876	0.876	0.876	0.876	0.876	0.876
5.5	0.868	0.868	0.867	0.867	0.867	0.867	0.866	0.866	0.866
6.0	0.863	0.862	0.862	0.862	0.862	0.861	0.861	0.861	0.860
6.5	0.852	0.852	0.853	0.853	0.853	0.853	0.853	0.853	0.854
7.0	0.775	0.776	0.776	0.778	0.779	0.779	0.780	0.781	0.782
7.5	0.706	0.707	0.707	0.710	0.712	0.712	0.714	0.715	0.716
8.0	0.645	0.646	0.646	0.649	0.652	0.653	0.655	0.656	0.657
8.5	0.590	0.592	0.592	0.596	0.599	0.600	0.602	0.603	0.604
9.0	0.543	0.544	0.544	0.548	0.551	0.552	0.555	0.556	0.557
9.5	0.500	0.501	0.501	0.506	0.509	0.510	0.512	0.513	0.515
10.0	0.462	0.463	0.463	0.468	0.471	0.472	0.474	0.475	0.476
10.5	0.428	0.429	0.429	0.433	0.436	0.436	0.439	0.440	0.436
11.0	0.397	0.398	0.398	0.402	0.404	0.402	0.388	0.377	0.366
11.5	0.369	0.370	0.370	0.364	0.352	0.341	0.332	0.323	0.314
12.0	0.344	0.334	0.322	0.313	0.304	0.295	0.288	0.280	0.273
12.5	0.299	0.290	0.281	0.273	0.266	0.259	0.252	0.246	0.240
13.0	0.262	0.255	0.247	0.241	0.234	0.228	0.223	0.218	0.212
13.5	0.232	0.226	0.220	0.214	0.208	0.203	0.198	0.194	0.189
14.0	0.208	0.202	0.196	0.191	0.186	0.182	0.178	0.174	0.170
14.5	0.186	0.181	0.176	0.172	0.168	0.164	0.160	0.156	0.153
15.0	0.168	0.164	0.159	0.155	0.152	0.148	0.145	0.141	0.138
15.5	0.152	0.148	0.145	0.141	0.138	0.134	0.131	0.128	0.126
16.0	0.139	0.135	0.132	0.129	0.126	0.123	0.120	0.117	0.115
16.5	0.127	0.124	0.121	0.118	0.115	0.112	0.110	0.107	0.105
17.0	0.116	0.114	0.111	0.108	0.106	0.103	0.101	0.099	0.097
17.5	0.107	0.104	0.102	0.100	0.097	0.095	0.093	0.091	0.089
18.0	0.099	0.096	0.094	0.092	0.090	0.088	0.086	0.084	0.082
18.5	0.092	0.089	0.087	0.085	0.083	0.082	0.080	0.078	0.076
19.0	0.085	0.083	0.081	0.079	0.077	0.076	0.074	0.073	0.071
19.5	0.079	0.077	0.075	0.074	0.072	0.071	0.069	0.068	0.066
20.0	0.074	0.072	0.070	0.069	0.067	0.066	0.064	0.063	0.062
20.5*	0.068	0.067	0.065	0.064	0.062	0.061	0.059	0.058	0.057
21.0*	0.062	0.061	0.059	0.058	0.057	0.056	0.054	0.053	0.052
21.5*	0.056	0.054	0.053	0.052	0.050	0.050	0.048	0.047	0.047
22.0*	0.049	0.047	0.046	0.045	0.044	0.043	0.042	0.041	0.041
22.5*	0.041	0.040	0.039	0.039	0.038	0.037	0.036	0.035	0.035
23.0*	0.038	0.037	0.036	0.035	0.034	0.034	0.033	0.032	0.032
23.5*	0.036	0.035	0.034	0.033	0.032	0.032	0.031	0.030	0.030
24.0*	0.034	0.033	0.032	0.031	0.030	0.030	0.029	0.029	0.028
24.5*	0.031	0.031	0.030	0.029	0.028	0.028	0.027	0.027	0.026
25.0*	0.029	0.028	0.028	0.027	0.026	0.026	0.025	0.025	0.024

* These values are based on a yield and load optimized operation that is not feasible at all sites.

Nordex N131/3900 IEC S – Thrust curves – Mode 11

for hub heights 84 m, 114 m and 120 m (mode not available for 134 m)								
wind speed v_H [m/s]	Thrust coefficients c_T at air density ρ [kg/m ³]							
	1.125	1.150	1.175	1.200	1.225	1.250	1.275	1.300
3.0	0.908	0.909	0.910	0.910	0.911	0.912	0.913	0.913
3.5	0.902	0.903	0.903	0.904	0.904	0.905	0.905	0.906
4.0	0.893	0.893	0.894	0.894	0.894	0.894	0.894	0.895
4.5	0.884	0.884	0.884	0.884	0.884	0.884	0.884	0.885
5.0	0.875	0.875	0.875	0.875	0.875	0.875	0.875	0.875
5.5	0.866	0.866	0.865	0.865	0.865	0.865	0.865	0.864
6.0	0.860	0.860	0.860	0.860	0.859	0.859	0.859	0.859
6.5	0.854	0.854	0.854	0.854	0.854	0.854	0.854	0.854
7.0	0.782	0.783	0.785	0.786	0.787	0.788	0.789	0.790
7.5	0.717	0.719	0.721	0.723	0.725	0.727	0.728	0.730
8.0	0.658	0.661	0.664	0.666	0.669	0.672	0.672	0.675
8.5	0.606	0.609	0.612	0.614	0.618	0.621	0.621	0.624
9.0	0.559	0.562	0.565	0.568	0.572	0.574	0.575	0.578
9.5	0.516	0.520	0.523	0.525	0.529	0.531	0.532	0.516
10.0	0.478	0.481	0.484	0.468	0.455	0.443	0.432	0.422
10.5	0.422	0.410	0.399	0.389	0.380	0.371	0.362	0.354
11.0	0.357	0.348	0.339	0.331	0.324	0.316	0.310	0.303
11.5	0.307	0.299	0.292	0.286	0.280	0.274	0.268	0.263
12.0	0.267	0.261	0.255	0.249	0.244	0.239	0.234	0.230
12.5	0.234	0.229	0.224	0.220	0.215	0.211	0.206	0.202
13.0	0.208	0.203	0.199	0.195	0.191	0.187	0.183	0.180
13.5	0.185	0.181	0.177	0.174	0.170	0.167	0.164	0.161
14.0	0.166	0.162	0.159	0.156	0.153	0.150	0.147	0.144
14.5	0.150	0.146	0.143	0.141	0.138	0.135	0.133	0.130
15.0	0.135	0.133	0.130	0.127	0.125	0.123	0.120	0.118
15.5	0.123	0.121	0.118	0.116	0.114	0.112	0.110	0.108
16.0	0.112	0.110	0.108	0.106	0.104	0.102	0.100	0.099
16.5	0.103	0.101	0.099	0.097	0.095	0.094	0.092	0.090
17.0	0.095	0.093	0.091	0.089	0.088	0.086	0.085	0.083
17.5	0.087	0.086	0.084	0.083	0.081	0.080	0.078	0.077
18.0	0.081	0.079	0.078	0.076	0.075	0.074	0.072	0.071
18.5	0.075	0.074	0.072	0.071	0.070	0.068	0.067	0.066
19.0	0.070	0.068	0.067	0.066	0.065	0.064	0.063	0.062
19.5	0.065	0.064	0.063	0.062	0.061	0.060	0.059	0.058
20.0	0.061	0.060	0.059	0.058	0.057	0.056	0.055	0.054
20.5*	0.056	0.056	0.055	0.054	0.053	0.052	0.051	0.050
21.0*	0.051	0.051	0.050	0.049	0.048	0.047	0.046	0.046
21.5*	0.046	0.045	0.044	0.044	0.043	0.042	0.041	0.041
22.0*	0.040	0.039	0.039	0.038	0.037	0.037	0.036	0.035
22.5*	0.034	0.034	0.033	0.032	0.032	0.031	0.031	0.030
23.0*	0.031	0.031	0.030	0.030	0.029	0.029	0.028	0.028
23.5*	0.029	0.029	0.028	0.028	0.027	0.027	0.027	0.026
24.0*	0.028	0.027	0.027	0.026	0.026	0.025	0.025	0.024
24.5*	0.026	0.025	0.025	0.025	0.024	0.024	0.023	0.023
25.0*	0.024	0.024	0.023	0.023	0.023	0.022	0.022	0.021

* These values are based on a yield and load optimized operation that is not feasible at all sites.

Nordex N131/3900 IEC S – Thrust curves – Mode 12

for hub heights 84 m, 114 m and 120 m (mode not available for 134 m)									
wind speed v_H [m/s]	Thrust coefficients c_T at air density ρ [kg/m ³]								
	0.900	0.925	0.950	0.975	1.000	1.025	1.050	1.075	1.100
3.0	0.902	0.902	0.902	0.902	0.903	0.904	0.905	0.906	0.907
3.5	0.895	0.896	0.897	0.898	0.899	0.900	0.900	0.901	0.902
4.0	0.889	0.890	0.890	0.891	0.891	0.892	0.892	0.892	0.893
4.5	0.883	0.883	0.883	0.883	0.884	0.884	0.884	0.884	0.884
5.0	0.876	0.876	0.876	0.876	0.876	0.876	0.876	0.876	0.876
5.5	0.869	0.868	0.868	0.868	0.867	0.867	0.867	0.866	0.866
6.0	0.863	0.863	0.863	0.862	0.862	0.862	0.861	0.861	0.861
6.5	0.826	0.826	0.826	0.827	0.827	0.827	0.828	0.828	0.828
7.0	0.749	0.750	0.751	0.752	0.752	0.753	0.753	0.754	0.755
7.5	0.681	0.681	0.683	0.684	0.685	0.686	0.686	0.688	0.689
8.0	0.620	0.621	0.623	0.624	0.626	0.626	0.627	0.629	0.631
8.5	0.567	0.568	0.570	0.572	0.573	0.574	0.575	0.577	0.579
9.0	0.521	0.522	0.524	0.525	0.527	0.528	0.528	0.530	0.533
9.5	0.479	0.480	0.482	0.484	0.486	0.486	0.487	0.489	0.491
10.0	0.442	0.443	0.446	0.447	0.448	0.449	0.450	0.452	0.454
10.5	0.409	0.410	0.412	0.413	0.415	0.415	0.416	0.418	0.422
11.0	0.379	0.380	0.382	0.383	0.385	0.387	0.380	0.368	0.357
11.5	0.352	0.353	0.357	0.358	0.344	0.333	0.324	0.315	0.307
12.0	0.330	0.328	0.316	0.305	0.296	0.288	0.281	0.274	0.267
12.5	0.293	0.283	0.274	0.266	0.259	0.252	0.246	0.240	0.234
13.0	0.256	0.249	0.242	0.235	0.229	0.223	0.218	0.212	0.207
13.5	0.227	0.221	0.214	0.209	0.204	0.198	0.194	0.189	0.185
14.0	0.203	0.197	0.192	0.187	0.182	0.178	0.173	0.169	0.166
14.5	0.182	0.177	0.172	0.168	0.164	0.160	0.156	0.153	0.149
15.0	0.164	0.160	0.156	0.152	0.148	0.145	0.141	0.138	0.135
15.5	0.149	0.145	0.141	0.138	0.134	0.131	0.128	0.126	0.123
16.0	0.136	0.132	0.129	0.126	0.123	0.120	0.117	0.115	0.112
16.5	0.124	0.121	0.118	0.115	0.112	0.110	0.107	0.105	0.103
17.0	0.114	0.111	0.108	0.106	0.103	0.101	0.099	0.097	0.095
17.5	0.105	0.102	0.100	0.097	0.095	0.093	0.091	0.089	0.087
18.0	0.097	0.094	0.092	0.090	0.088	0.086	0.084	0.082	0.081
18.5	0.090	0.087	0.085	0.083	0.082	0.080	0.078	0.076	0.075
19.0	0.083	0.081	0.079	0.077	0.076	0.074	0.072	0.071	0.070
19.5	0.077	0.076	0.074	0.072	0.070	0.069	0.068	0.066	0.065
20.0	0.072	0.070	0.069	0.067	0.066	0.064	0.063	0.062	0.061
20.5*	0.067	0.065	0.064	0.062	0.061	0.059	0.058	0.057	0.056
21.0*	0.061	0.059	0.058	0.057	0.056	0.054	0.053	0.052	0.051
21.5*	0.054	0.053	0.052	0.050	0.050	0.048	0.047	0.047	0.046
22.0*	0.047	0.046	0.045	0.044	0.043	0.042	0.041	0.041	0.040

* These values are based on a yield and load optimized operation that is not feasible at all sites.

Nordex N131/3900 IEC S – Thrust curves – Mode 12

for hub heights 84 m, 114 m and 120 m (mode not available for 134 m)								
wind speed v_H [m/s]	Thrust coefficients c_T at air density ρ [kg/m ³]							
	1.125	1.150	1.175	1.200	1.225	1.250	1.275	1.300
3.0	0.908	0.909	0.910	0.911	0.911	0.912	0.913	0.913
3.5	0.902	0.903	0.903	0.904	0.904	0.905	0.905	0.906
4.0	0.893	0.893	0.894	0.894	0.894	0.894	0.895	0.895
4.5	0.884	0.884	0.884	0.884	0.885	0.885	0.885	0.885
5.0	0.876	0.876	0.876	0.876	0.876	0.876	0.875	0.875
5.5	0.866	0.866	0.866	0.866	0.865	0.865	0.865	0.865
6.0	0.861	0.860	0.860	0.860	0.860	0.860	0.859	0.859
6.5	0.829	0.829	0.830	0.830	0.831	0.831	0.831	0.831
7.0	0.757	0.758	0.759	0.760	0.762	0.762	0.763	0.764
7.5	0.691	0.694	0.695	0.697	0.698	0.700	0.700	0.702
8.0	0.633	0.636	0.637	0.640	0.642	0.644	0.644	0.647
8.5	0.582	0.584	0.586	0.589	0.591	0.593	0.594	0.596
9.0	0.535	0.538	0.540	0.543	0.545	0.547	0.548	0.550
9.5	0.494	0.497	0.498	0.501	0.503	0.506	0.507	0.502
10.0	0.456	0.459	0.462	0.456	0.443	0.431	0.420	0.410
10.5	0.412	0.400	0.389	0.379	0.370	0.361	0.353	0.345
11.0	0.348	0.339	0.331	0.323	0.316	0.308	0.302	0.296
11.5	0.299	0.292	0.285	0.279	0.273	0.267	0.262	0.256
12.0	0.260	0.254	0.249	0.243	0.238	0.233	0.229	0.224
12.5	0.229	0.224	0.219	0.214	0.210	0.206	0.202	0.198
13.0	0.203	0.198	0.194	0.190	0.186	0.182	0.179	0.176
13.5	0.181	0.177	0.173	0.170	0.166	0.163	0.160	0.157
14.0	0.162	0.159	0.155	0.152	0.149	0.146	0.144	0.141
14.5	0.146	0.143	0.140	0.137	0.135	0.132	0.130	0.127
15.0	0.132	0.130	0.127	0.124	0.122	0.120	0.118	0.116
15.5	0.120	0.118	0.116	0.113	0.111	0.109	0.107	0.105
16.0	0.110	0.108	0.106	0.104	0.102	0.100	0.098	0.096
16.5	0.101	0.099	0.097	0.095	0.093	0.092	0.090	0.088
17.0	0.093	0.091	0.089	0.087	0.086	0.084	0.083	0.082
17.5	0.086	0.084	0.082	0.081	0.079	0.078	0.076	0.075
18.0	0.079	0.078	0.076	0.075	0.073	0.072	0.071	0.070
18.5	0.073	0.072	0.071	0.069	0.068	0.067	0.066	0.065
19.0	0.068	0.067	0.066	0.065	0.064	0.062	0.061	0.060
19.5	0.064	0.062	0.061	0.060	0.059	0.058	0.057	0.056
20.0	0.060	0.058	0.057	0.056	0.055	0.054	0.054	0.053
20.5*	0.056	0.054	0.053	0.052	0.051	0.050	0.050	0.049
21.0*	0.051	0.049	0.048	0.047	0.046	0.046	0.046	0.045
21.5*	0.045	0.044	0.043	0.042	0.041	0.041	0.041	0.040
22.0*	0.039	0.038	0.037	0.037	0.036	0.035	0.035	0.035

* These values are based on a yield and load optimized operation that is not feasible at all sites.

Nordex N131/3900 IEC S – Thrust curves – Mode 13

for hub heights 84 m, 114 m, 120 m and 134 m									
wind speed v_H [m/s]	Thrust coefficients c_T at air density ρ [kg/m ³]								
	0.900	0.925	0.950	0.975	1.000	1.025	1.050	1.075	1.100
3.0	0.902	0.902	0.902	0.902	0.903	0.904	0.905	0.906	0.907
3.5	0.896	0.896	0.897	0.898	0.899	0.900	0.900	0.901	0.902
4.0	0.890	0.890	0.891	0.891	0.891	0.892	0.892	0.893	0.893
4.5	0.883	0.883	0.884	0.884	0.884	0.884	0.884	0.884	0.884
5.0	0.877	0.877	0.877	0.876	0.876	0.876	0.876	0.876	0.876
5.5	0.869	0.868	0.868	0.868	0.868	0.867	0.867	0.867	0.867
6.0	0.864	0.863	0.863	0.863	0.862	0.862	0.862	0.862	0.861
6.5	0.798	0.799	0.800	0.800	0.800	0.801	0.801	0.802	0.802
7.0	0.722	0.723	0.725	0.725	0.725	0.726	0.727	0.728	0.729
7.5	0.654	0.656	0.658	0.658	0.658	0.660	0.661	0.662	0.664
8.0	0.595	0.597	0.600	0.600	0.600	0.601	0.603	0.605	0.606
8.5	0.544	0.546	0.548	0.549	0.549	0.550	0.552	0.554	0.556
9.0	0.498	0.500	0.503	0.503	0.503	0.505	0.506	0.508	0.512
9.5	0.458	0.460	0.463	0.463	0.466	0.470	0.473	0.477	0.480
10.0	0.424	0.428	0.433	0.435	0.437	0.440	0.442	0.445	0.447
10.5	0.399	0.402	0.406	0.407	0.409	0.411	0.413	0.414	0.416
11.0	0.374	0.377	0.380	0.381	0.382	0.383	0.374	0.359	0.348
11.5	0.351	0.353	0.355	0.356	0.338	0.326	0.316	0.307	0.299
12.0	0.330	0.327	0.310	0.299	0.290	0.281	0.274	0.267	0.260
12.5	0.288	0.277	0.268	0.260	0.253	0.246	0.240	0.234	0.229
13.0	0.251	0.243	0.236	0.229	0.223	0.218	0.212	0.207	0.202
13.5	0.222	0.216	0.210	0.204	0.199	0.194	0.189	0.185	0.180
14.0	0.198	0.192	0.187	0.182	0.178	0.173	0.169	0.165	0.162
14.5	0.178	0.173	0.168	0.164	0.160	0.156	0.152	0.149	0.146
15.0	0.160	0.156	0.152	0.148	0.145	0.141	0.138	0.135	0.132
15.5	0.146	0.142	0.138	0.135	0.131	0.128	0.126	0.123	0.120
16.0	0.133	0.129	0.126	0.123	0.120	0.117	0.114	0.112	0.110
16.5	0.121	0.118	0.115	0.112	0.110	0.107	0.105	0.103	0.100
17.0	0.111	0.108	0.106	0.103	0.101	0.099	0.096	0.094	0.092
17.5	0.102	0.100	0.097	0.095	0.093	0.091	0.089	0.087	0.085
18.0	0.095	0.092	0.090	0.088	0.086	0.084	0.082	0.080	0.079
18.5	0.088	0.085	0.083	0.082	0.080	0.078	0.076	0.075	0.073
19.0	0.081	0.079	0.078	0.076	0.074	0.072	0.071	0.069	0.068
19.5	0.076	0.074	0.072	0.070	0.069	0.068	0.066	0.065	0.064
20.0	0.071	0.069	0.067	0.066	0.064	0.063	0.062	0.060	0.059

* These values are based on a yield and load optimized operation that is not feasible at all sites.

Nordex N131/3900 IEC S – Thrust curves – Mode 13

for hub heights 84 m, 114 m, 120 m and 134 m								
wind speed v_H [m/s]	Thrust coefficients c_T at air density ρ [kg/m ³]							
	1.125	1.150	1.175	1.200	1.225	1.250	1.275	1.300
3.0	0.908	0.909	0.910	0.911	0.911	0.912	0.913	0.914
3.5	0.902	0.903	0.903	0.904	0.904	0.905	0.905	0.906
4.0	0.893	0.894	0.894	0.894	0.894	0.895	0.895	0.895
4.5	0.884	0.885	0.885	0.885	0.885	0.885	0.885	0.885
5.0	0.876	0.876	0.876	0.876	0.876	0.876	0.876	0.876
5.5	0.866	0.866	0.866	0.866	0.866	0.866	0.865	0.865
6.0	0.861	0.861	0.861	0.860	0.860	0.860	0.860	0.860
6.5	0.803	0.804	0.804	0.805	0.806	0.806	0.807	0.808
7.0	0.730	0.731	0.733	0.734	0.736	0.737	0.738	0.739
7.5	0.665	0.667	0.669	0.670	0.673	0.674	0.676	0.677
8.0	0.607	0.610	0.612	0.614	0.616	0.618	0.620	0.622
8.5	0.556	0.559	0.562	0.563	0.567	0.570	0.573	0.576
9.0	0.515	0.519	0.523	0.526	0.530	0.532	0.535	0.537
9.5	0.482	0.485	0.488	0.490	0.493	0.494	0.496	0.490
10.0	0.449	0.451	0.453	0.448	0.432	0.420	0.409	0.399
10.5	0.404	0.390	0.379	0.369	0.360	0.352	0.344	0.336
11.0	0.339	0.330	0.322	0.315	0.307	0.301	0.294	0.288
11.5	0.292	0.285	0.278	0.272	0.266	0.260	0.255	0.250
12.0	0.254	0.248	0.243	0.237	0.232	0.228	0.223	0.219
12.5	0.223	0.218	0.214	0.209	0.205	0.201	0.197	0.193
13.0	0.198	0.194	0.189	0.186	0.182	0.178	0.175	0.171
13.5	0.176	0.173	0.169	0.166	0.162	0.159	0.156	0.153
14.0	0.158	0.155	0.152	0.149	0.146	0.143	0.140	0.138
14.5	0.143	0.140	0.137	0.134	0.132	0.129	0.127	0.124
15.0	0.129	0.127	0.124	0.122	0.119	0.117	0.115	0.113
15.5	0.118	0.115	0.113	0.111	0.109	0.107	0.105	0.103
16.0	0.107	0.105	0.103	0.101	0.099	0.098	0.096	0.094
16.5	0.098	0.096	0.095	0.093	0.091	0.090	0.088	0.086
17.0	0.091	0.089	0.087	0.086	0.084	0.082	0.081	0.080
17.5	0.084	0.082	0.080	0.079	0.078	0.076	0.075	0.074
18.0	0.077	0.076	0.074	0.073	0.072	0.070	0.069	0.068
18.5	0.072	0.070	0.069	0.068	0.067	0.066	0.064	0.063
19.0	0.067	0.066	0.064	0.063	0.062	0.061	0.060	0.059
19.5	0.062	0.061	0.060	0.059	0.058	0.057	0.056	0.055
20.0	0.058	0.057	0.056	0.055	0.054	0.053	0.052	0.052

* These values are based on a yield and load optimized operation that is not feasible at all sites.