

PLANIMETRIA DI TRACCIAMENTO NV05
 SCALA 1:2000



TABELLE TRACCIAMENTO NV05

566381.496 4433763.800	566330.354 4433812.661	566321.499 4433875.214	566185.570 4433895.820	566205.463 4433937.200
N 1.000 A 30.000 Sv 10.000 Prof 3.333333 m 0.046 Tl 4.666 Tc 3.334	N 1.000 A 25.000 Sv 8.889 Prof 4.147727 m 0.073 Tl 5.294 Tc 2.966	N 1.000 A 20.000 Sv 7.692 Prof 4.967273 m 0.100 Tl 5.922 Tc 2.598	N 1.000 A 15.000 Sv 6.667 Prof 5.793333 m 0.127 Tl 6.550 Tc 2.230	N 1.000 A 10.000 Sv 5.667 Prof 6.619333 m 0.154 Tl 7.178 Tc 1.862

PLANIMETRIA DI TRACCIAMENTO NV05a
 SCALA 1:2000



TABELLE TRACCIAMENTO NV05a

566204.900 4433908.070	566185.134 4433952.900	566154.170 4433916.764	566137.460 4433911.760
N 1.000 A 30.000 Sv 10.000 Prof 3.333333 m 0.046 Tl 4.666 Tc 3.334	N 1.000 A 25.000 Sv 8.889 Prof 4.147727 m 0.073 Tl 5.294 Tc 2.966	N 1.000 A 20.000 Sv 7.692 Prof 4.967273 m 0.100 Tl 5.922 Tc 2.598	N 1.000 A 15.000 Sv 6.667 Prof 5.793333 m 0.127 Tl 6.550 Tc 2.230



DETTAGLIO PAVIMENTAZIONE STRADALE TIPO 1
 SCALA 1:50

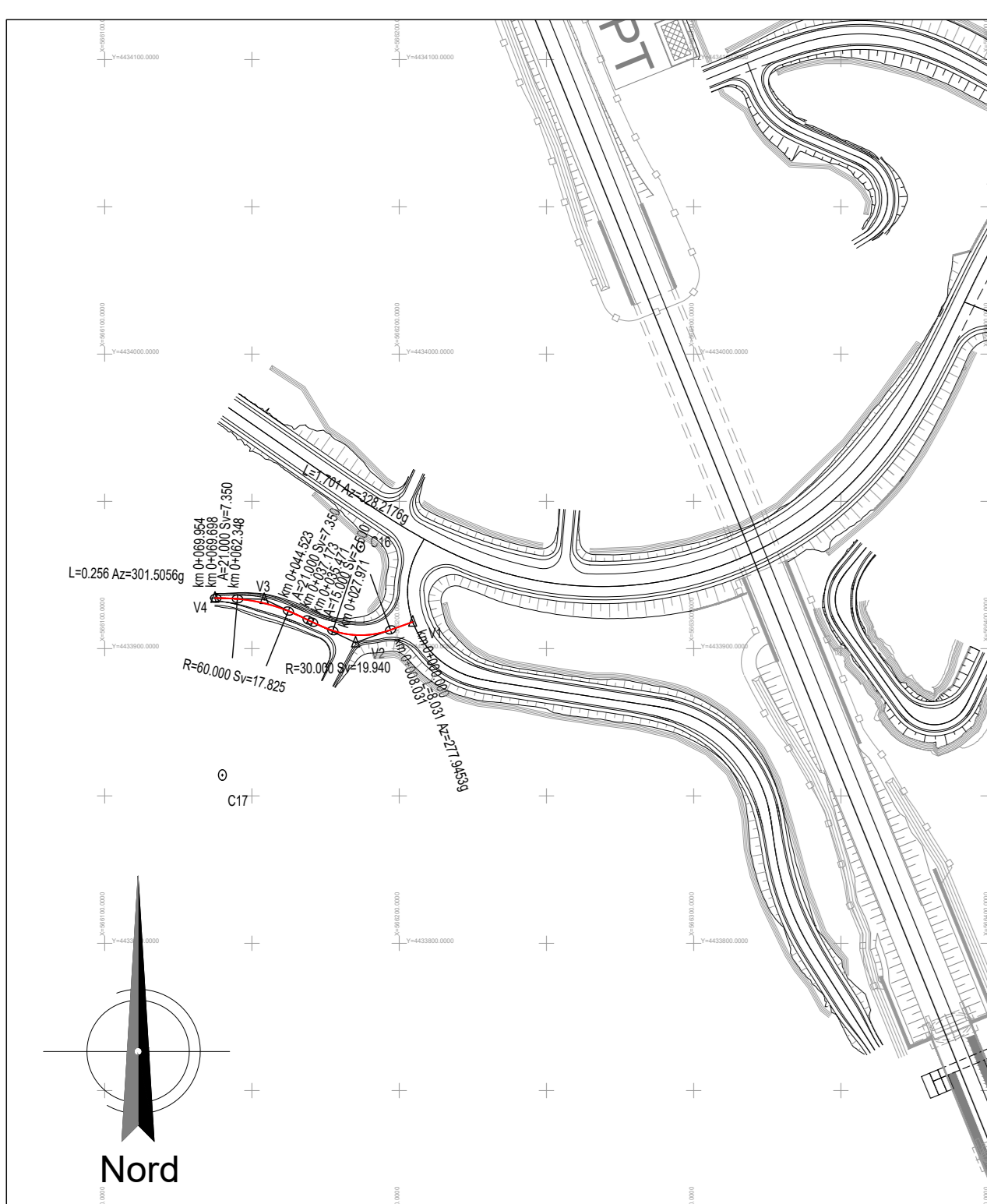
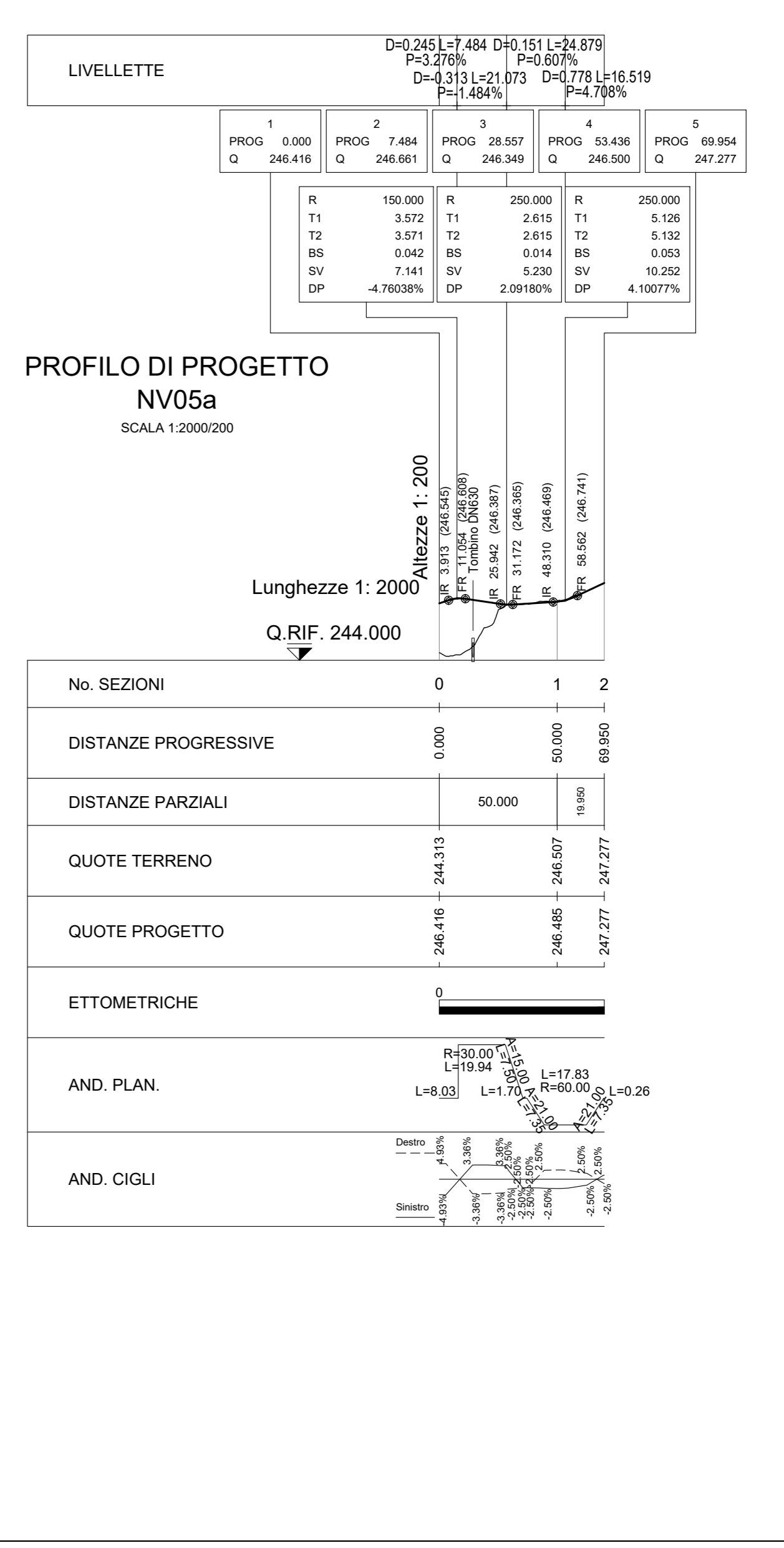
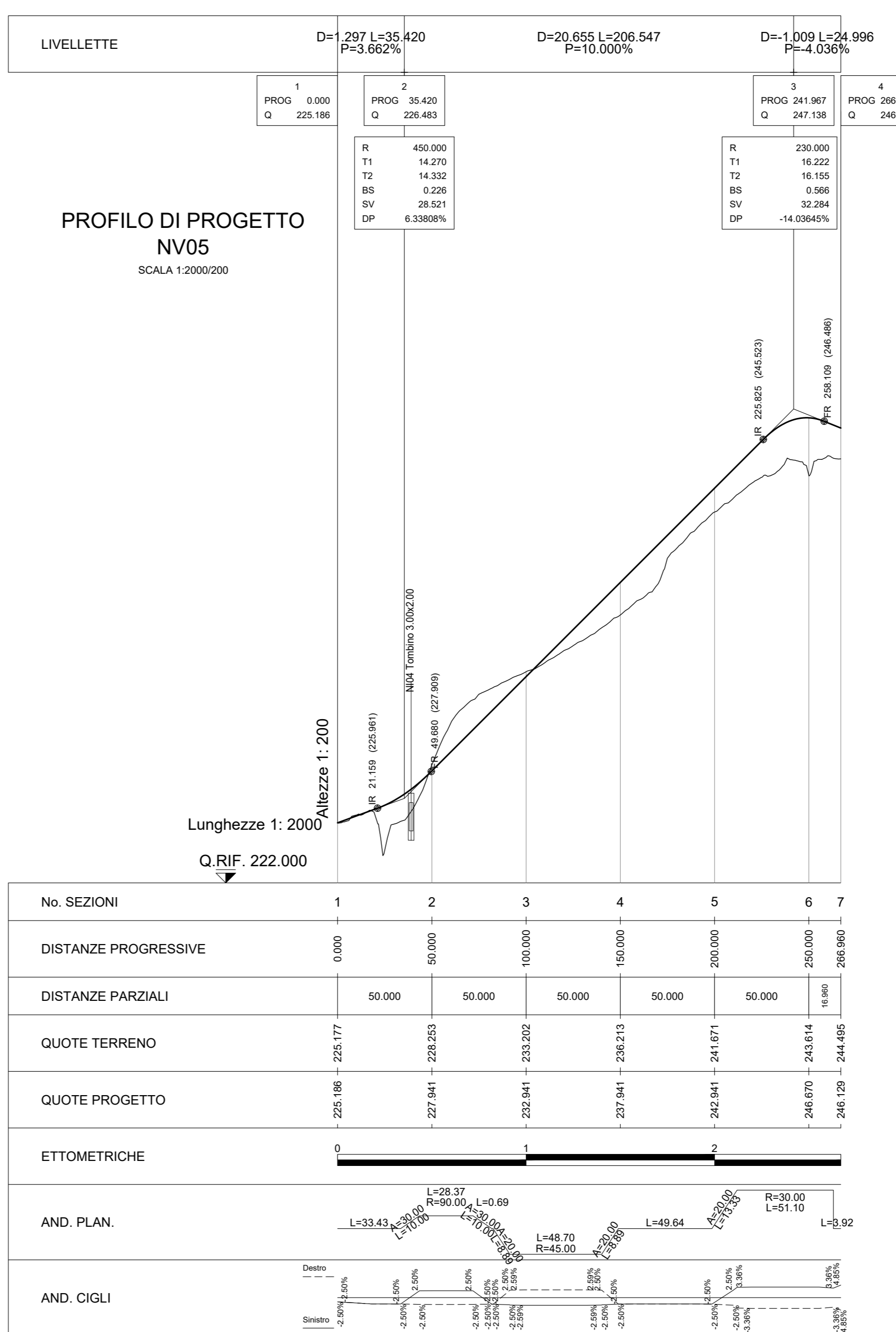
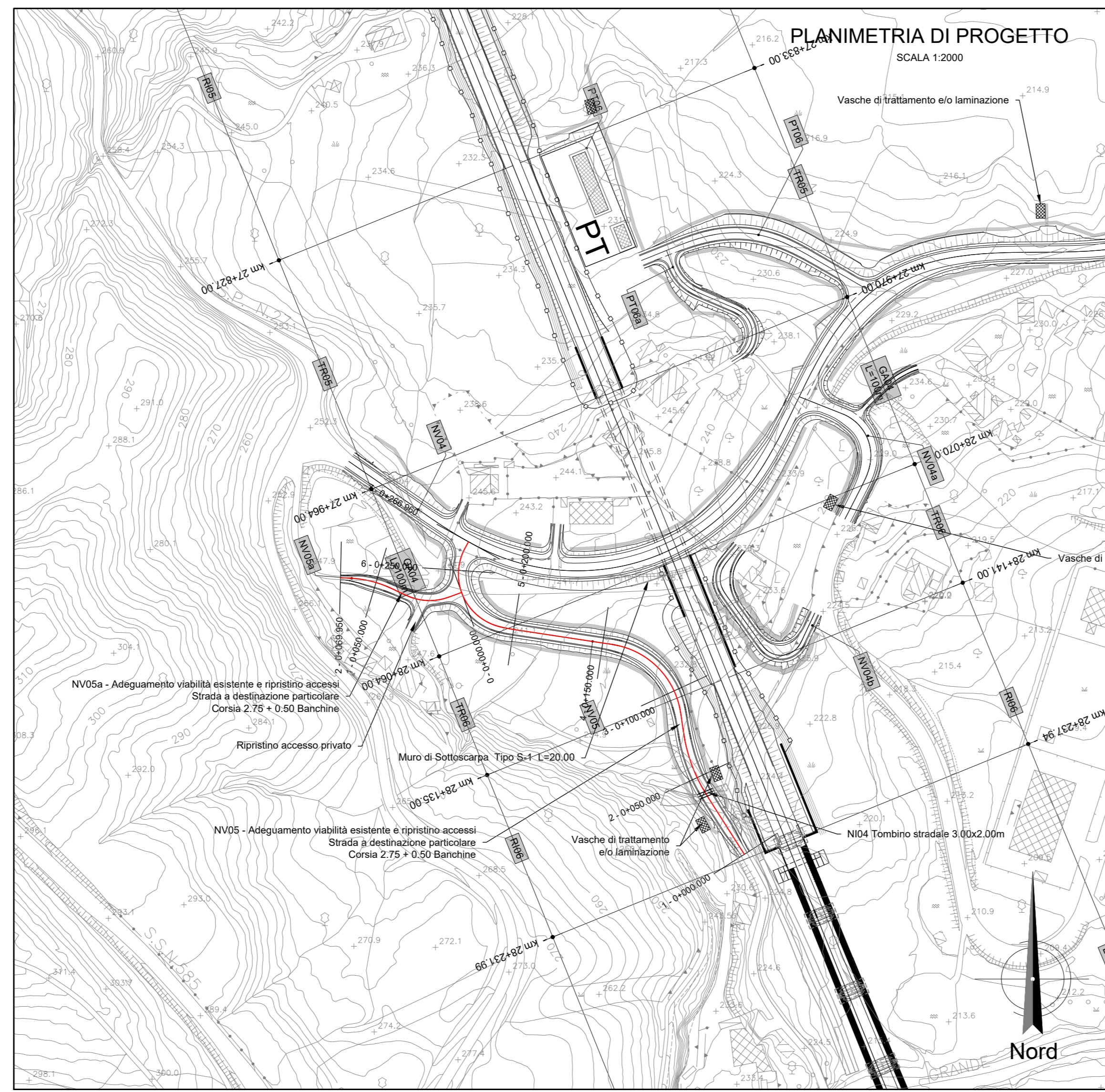
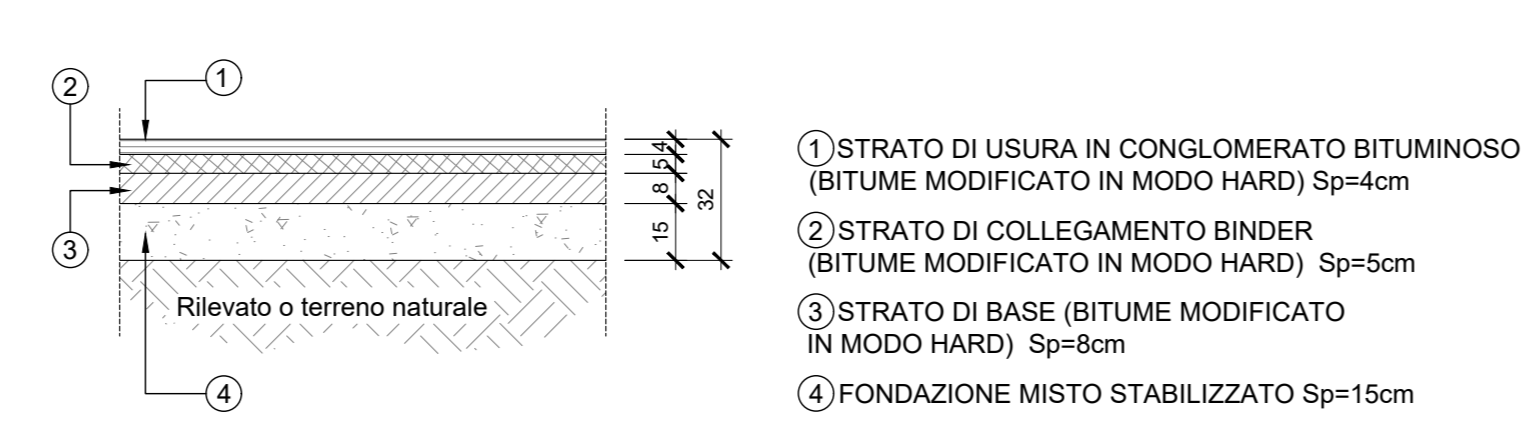

NV05, NV05a
 STRADA A DESTINAZIONE PARTICOLARE
 (L=6.50m - PAVIMENTATA)
 SEZIONE TIPO IN RILEVATO Hrl ≤ 4.00 m
 SCALA 1:50

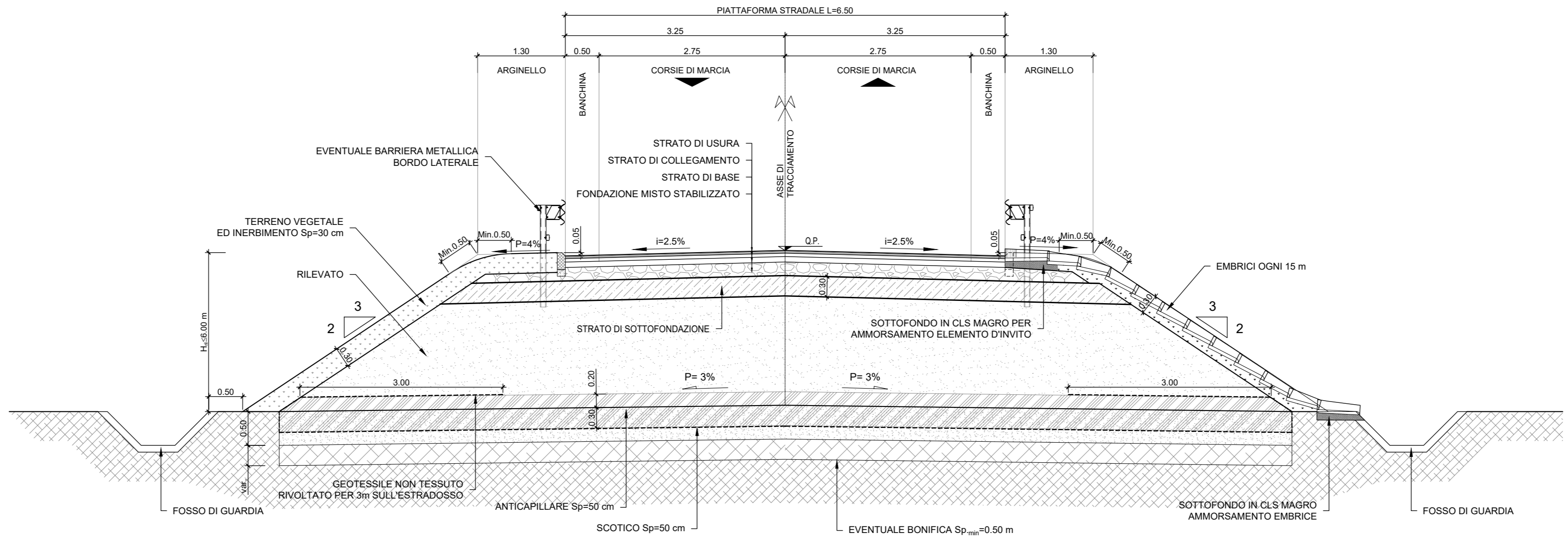

SEZIONE TIPO IN TRINCEA
 SCALA 1:50

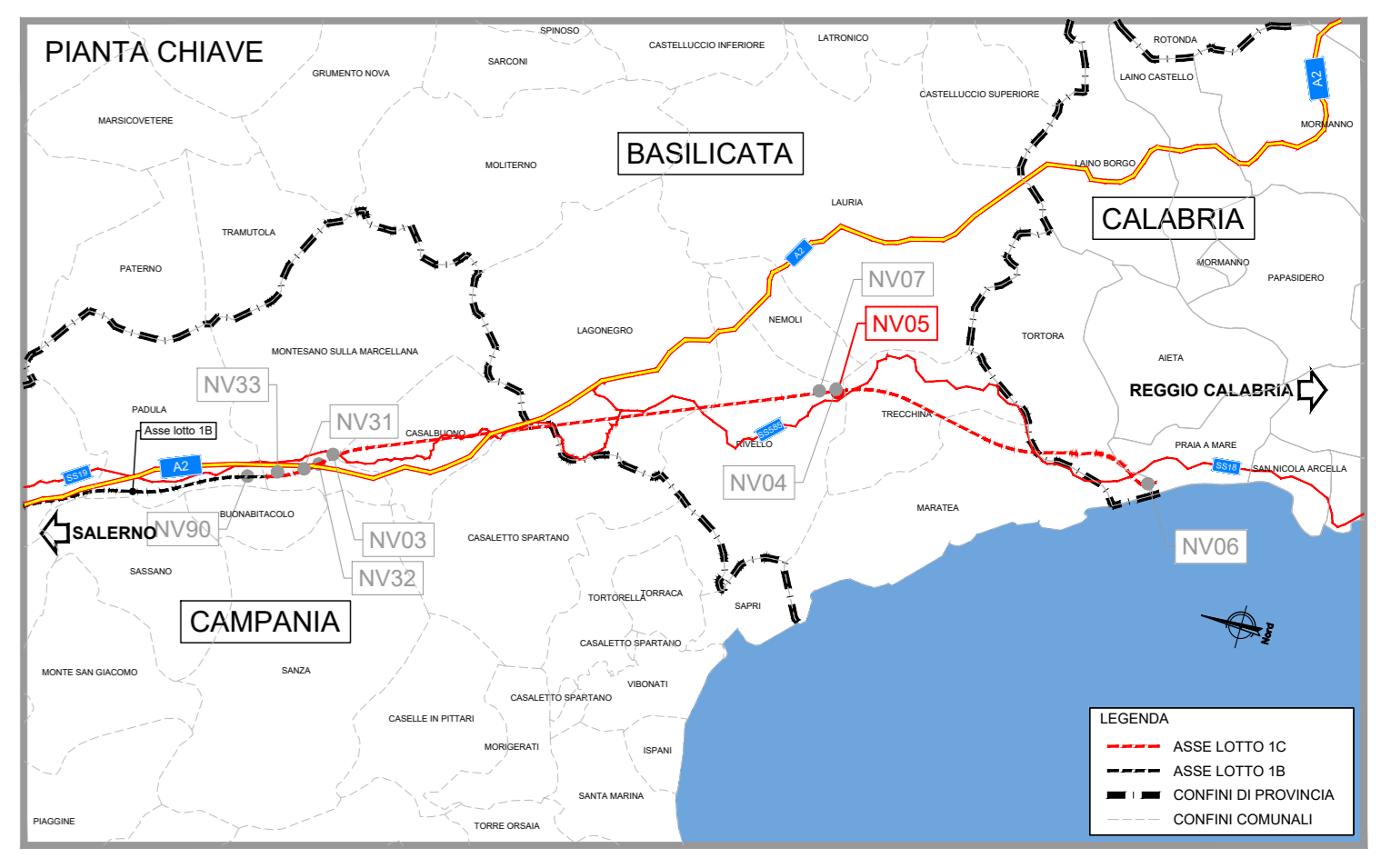
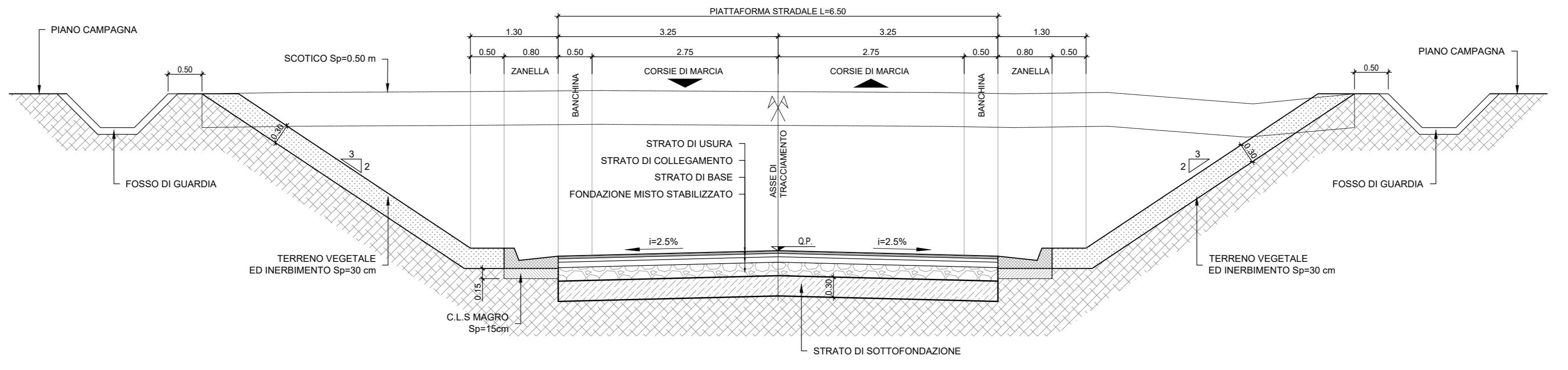

COMMITTENTE: **RFI** RETE FERROVIARIA ITALIANA GRUPPO FERROVIE DELLO STATO ITALIANE

PROGETTAZIONE: **ITALFER** GRUPPO FERROVIE DELLO STATO ITALIANE

U.O. PROGETTAZIONE LINEE, NODI E ARMAMENTO
 PROGETTO DI FATTIBILITA' TECNICA ED ECONOMICA
 LINEA SALERNO - REGGIO CALABRIA
 NUOVA LINEA AV SALERNO - REGGIO CALABRIA
 LOTTO 1C BATTIPAGLIA - PRAIA
 LOTTO 1C BUONABITACOLO - PRAIA
 VIABILITA' NV05/NV05a - Ricucitura viabilita' al km 28+173 e ripristino accessi
 Planoprofilo, tracciamento e sezione tipo

SCALA: varie

COMMESSA	LOTTO	FASE	ENTE	TIPO DOC.	OPERA/DISCIPLINA	PROGR.	REV.
RC2A	C1	R	13	LZ	NV0500	001	C

Rev.	Descrizione	Redatto	Data	Verificato	Data	Approvato	Data	Autorezzato Data
A	Emissione esecutiva	L. Pizzol	04/2021	F. Gatta	04/2021	L. Pizzol	04/2021	04/2021
B	Emissione esecutiva	L. Pizzol	05/2022	F. Gatta	05/2022	L. Pizzol	05/2022	05/2022
C	Emissione esecutiva	L. Pizzol	05/2023	F. Gatta	05/2023	L. Pizzol	05/2023	05/2023

File: RC2A.C.1.R.13.LZ.NV.05.0.0.001.C n. Elab.: