



REGIONE  
SICILIANA



LIBERO CONSORZIO  
COMUNALE DI PALERMO



COMUNE DI  
CORLEONE



COMUNE DI  
CONTESSA  
ENTELLINA



COMUNE DI  
MONREALE



COMUNE DI  
PIANA DEGLI  
ALBANESI



COMMITTENTE:

**RWE**

RWE RENEWABLES ITALIA S.R.L.  
via A. Doria, 41/G - 00192 ROMA (RM)  
P.IVA/C.F. 06400370968  
pec: rwerenewablesitaliasrl@legalmail.it

Titolo del Progetto:

**PARCO EOLICO CORLEONE-CONTESSA**

Documento:

**PROGETTO DEFINITIVO**

N° Documento:

**PELE-INT.6.1.a.01.3**

ID PROGETTO:

**PELE**

DISCIPLINA:

**P**

TIPOLOGIA:

FORMATO:

**A3**

TITOLO:

**Planimetria dell'occupazione del suolo del progetto**

FOGLIO:

**3/3**

SCALA:

**VARIE**

FILE:

**PELE-INT.6.1.a.01.3\_00.dwg**

**Progetto:**

ing. Riccardo Cangelosi



**REWIND ENERGY S.R.L.S.**  
viale Europa, 249 - 91011 ALCAMO (TP)  
P.IVA/C.F. 02785820818  
pec: rewindenergy@pec.it

ing. Gaetano Scurto

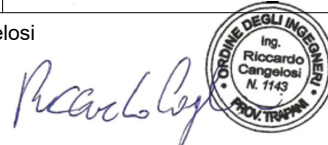

Rev:	Data Revisione	Descrizione Revisione	Redatto	Controllato	Approvato
01	19.02.2024	INTEGRAZIONE VIA	AB	GS	REWIND ENERGY
00	13.12.2022	PRIMA EMISSIONE	AB	GS	REWIND ENERGY

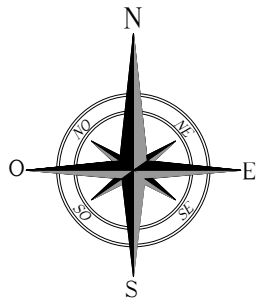

# INTERVENTI DI ADEGAMENTO VIABILITA' ESTERNA DI ACCESSO AL PARCO SU C.T.R. / CATASTALE





INT. 02

Comune di Monreale F.M. 164

STRADA PROVINCIALE n.27

lat. 37.881675°N long. 13.152083°E

**LEGENDA**

-  VIABILITA' ESISTENTE
-  AREA OCCUPAZIONE REVERSIBILE DI CANTIERE
-  AREA OCCUPAZIONE REVERSIBILE DI ESERCIZIO
-  AREA OCCUPAZIONE IRREVERSIBILE
-  CONFINE COMUNALE

Corografia – Scala 1:5.000

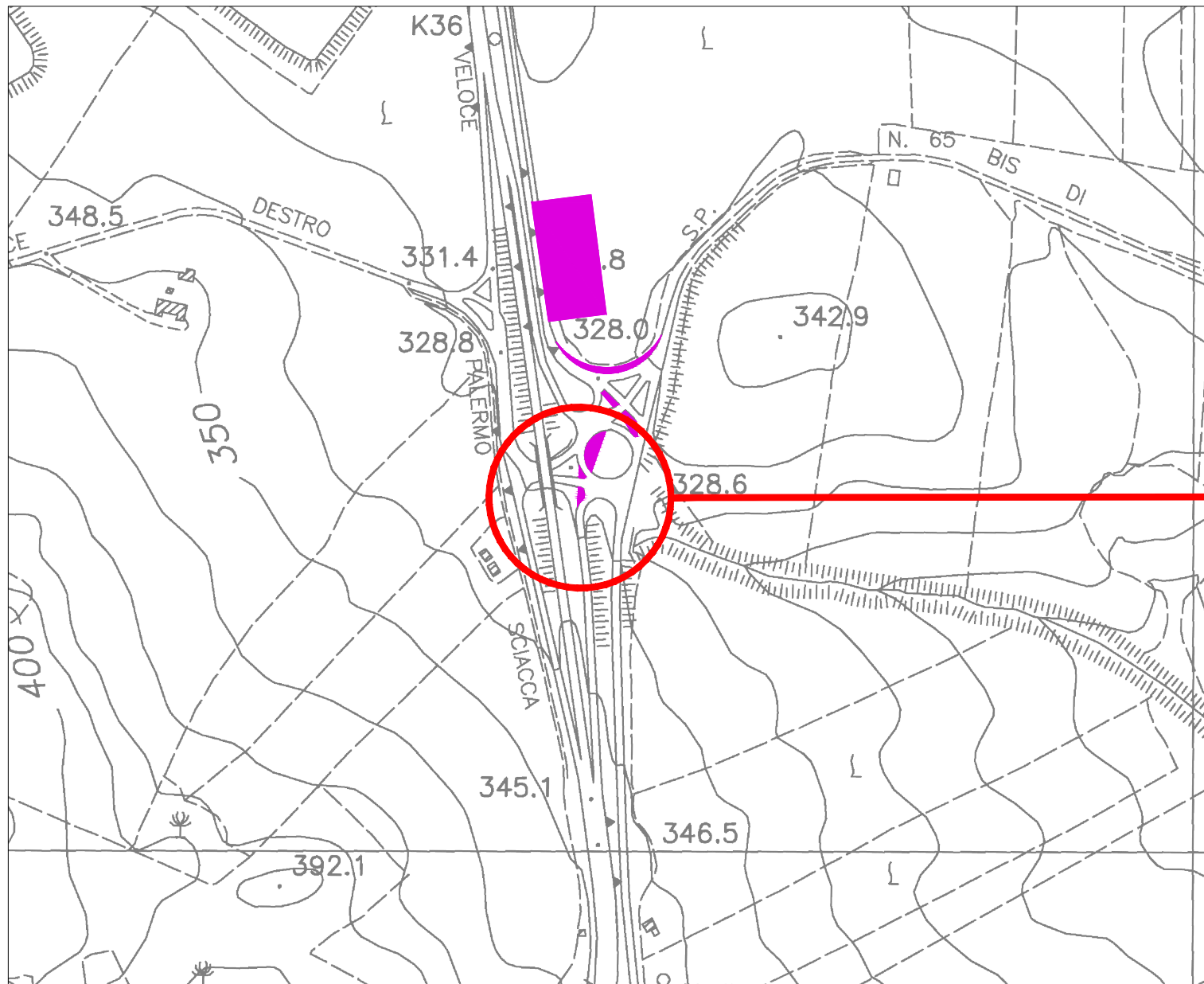

Planimetria catastale - Scala 1:500

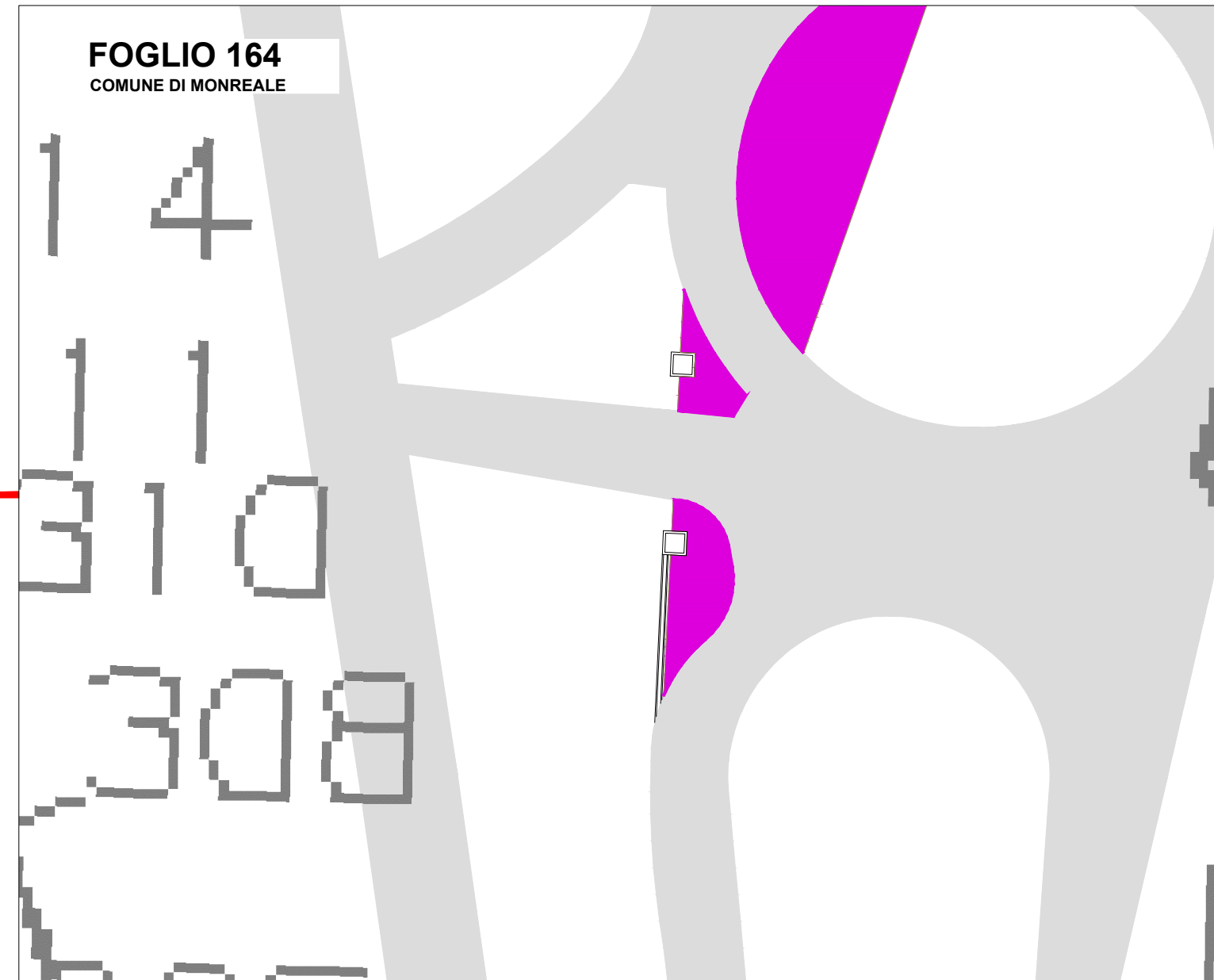

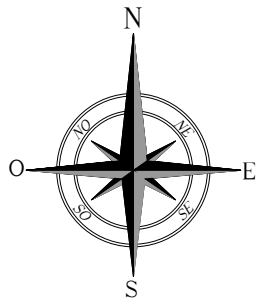

# INTERVENTI DI ADEGAMENTO VIABILITA' ESTERNA DI ACCESSO AL PARCO SU C.T.R. / CATASTALE





INT. 03

Comune di Monreale F.M. 164

STRADA PROVINCIALE n.27

lat. 37.881866°N long. 13.152041°E

**LEGENDA**

-  VIABILITA' ESISTENTE
-  AREA OCCUPAZIONE REVERSIBILE DI CANTIERE
-  AREA OCCUPAZIONE REVERSIBILE DI ESERCIZIO
-  AREA OCCUPAZIONE IRREVERSIBILE
-  CONFINE COMUNALE

Corografia – Scala 1:5.000

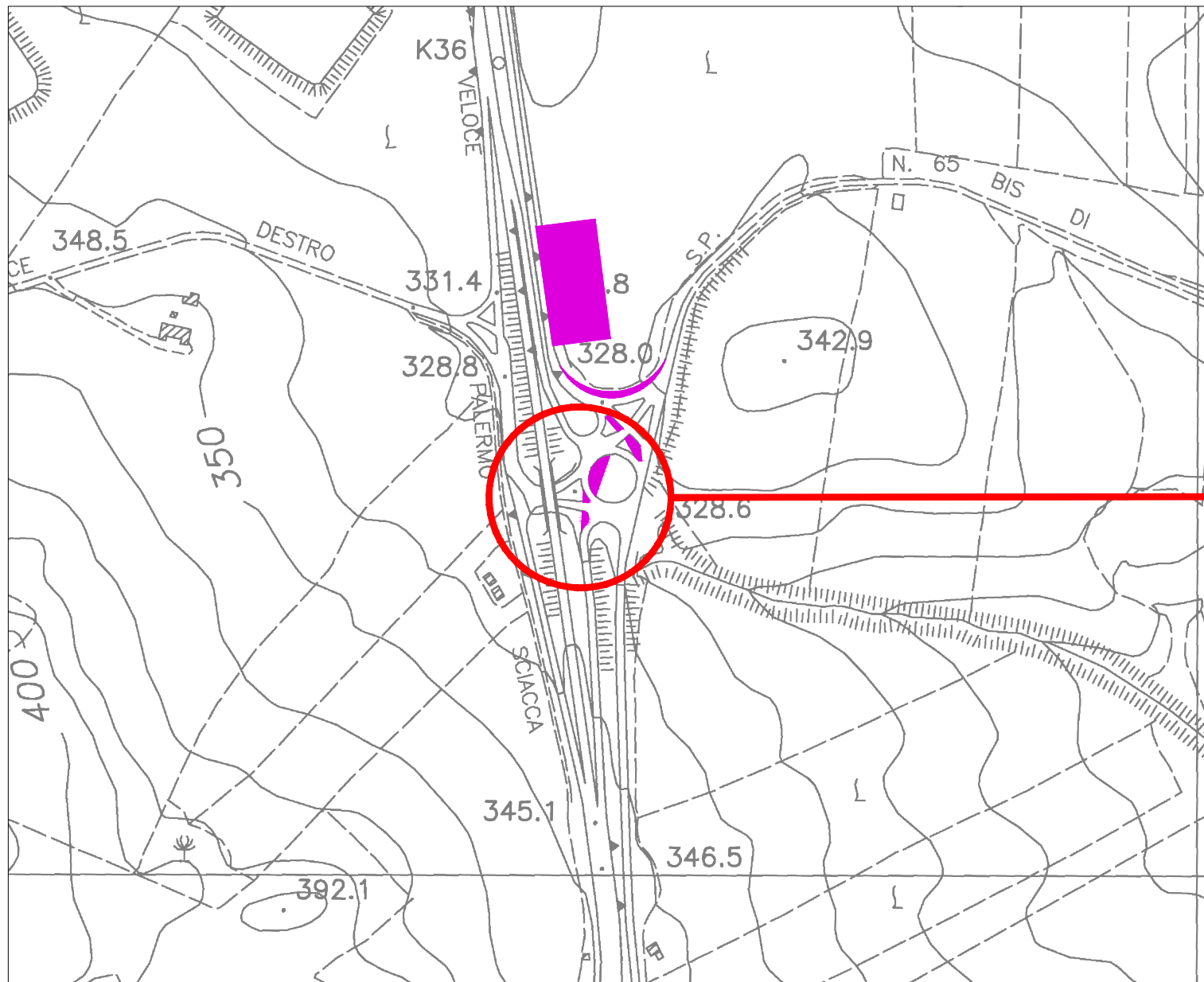

Planimetria catastale - Scala 1:500

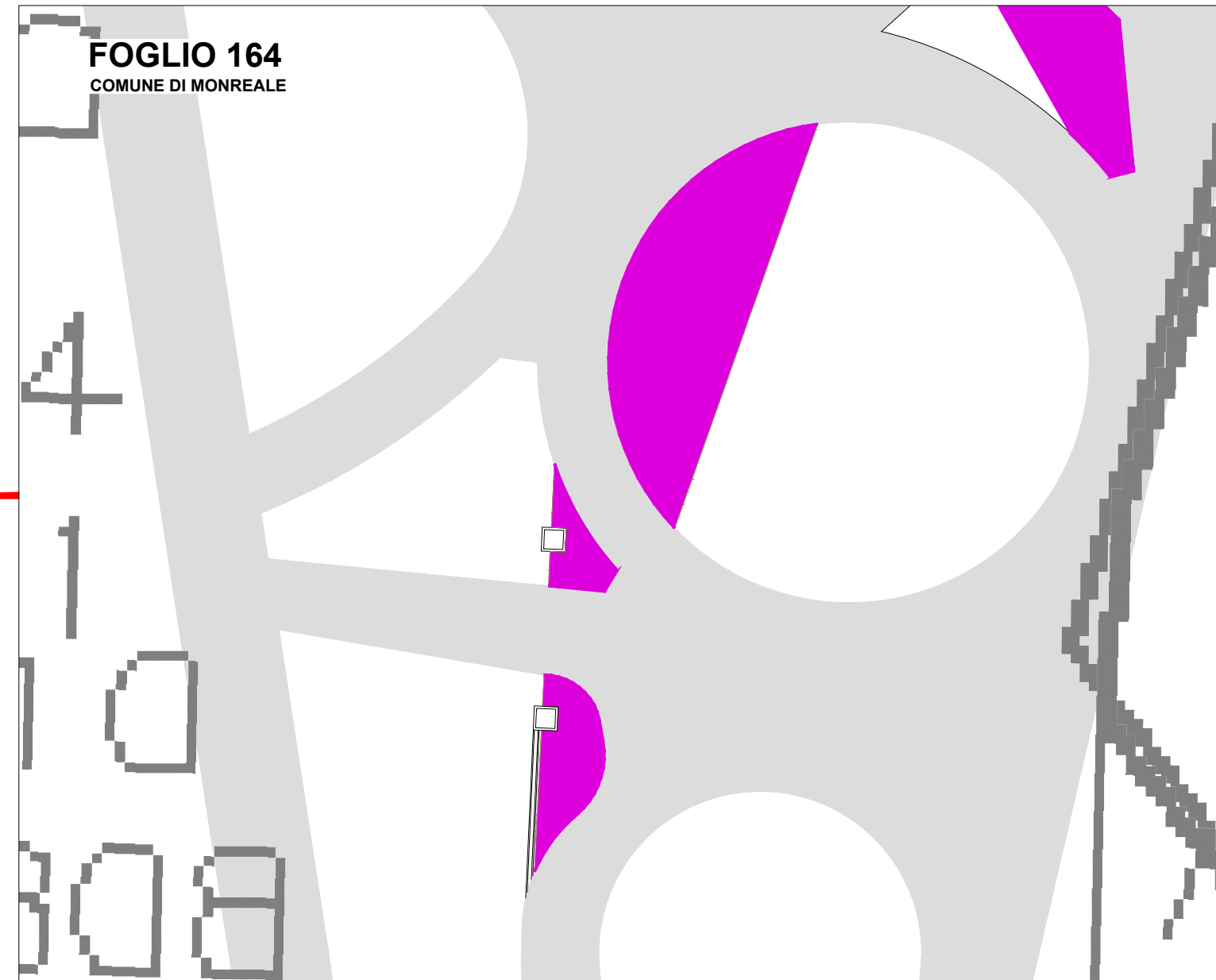

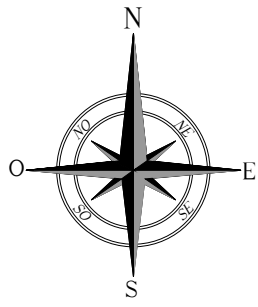

# INTERVENTI DI ADEGAMENTO VIABILITA' ESTERNA DI ACCESSO AL PARCO SU C.T.R. / CATASTALE





INT. 04

Comune di Monreale F.M. 164

STRADA PROVINCIALE n.27

lat. 37.881997°N long. 13.152193°E

**LEGENDA**

-  VIABILITA' ESISTENTE
-  AREA OCCUPAZIONE REVERSIBILE DI CANTIERE
-  AREA OCCUPAZIONE REVERSIBILE DI ESERCIZIO
-  AREA OCCUPAZIONE IRREVERSIBILE
-  CONFINE COMUNALE

Corografia – Scala 1:5.000

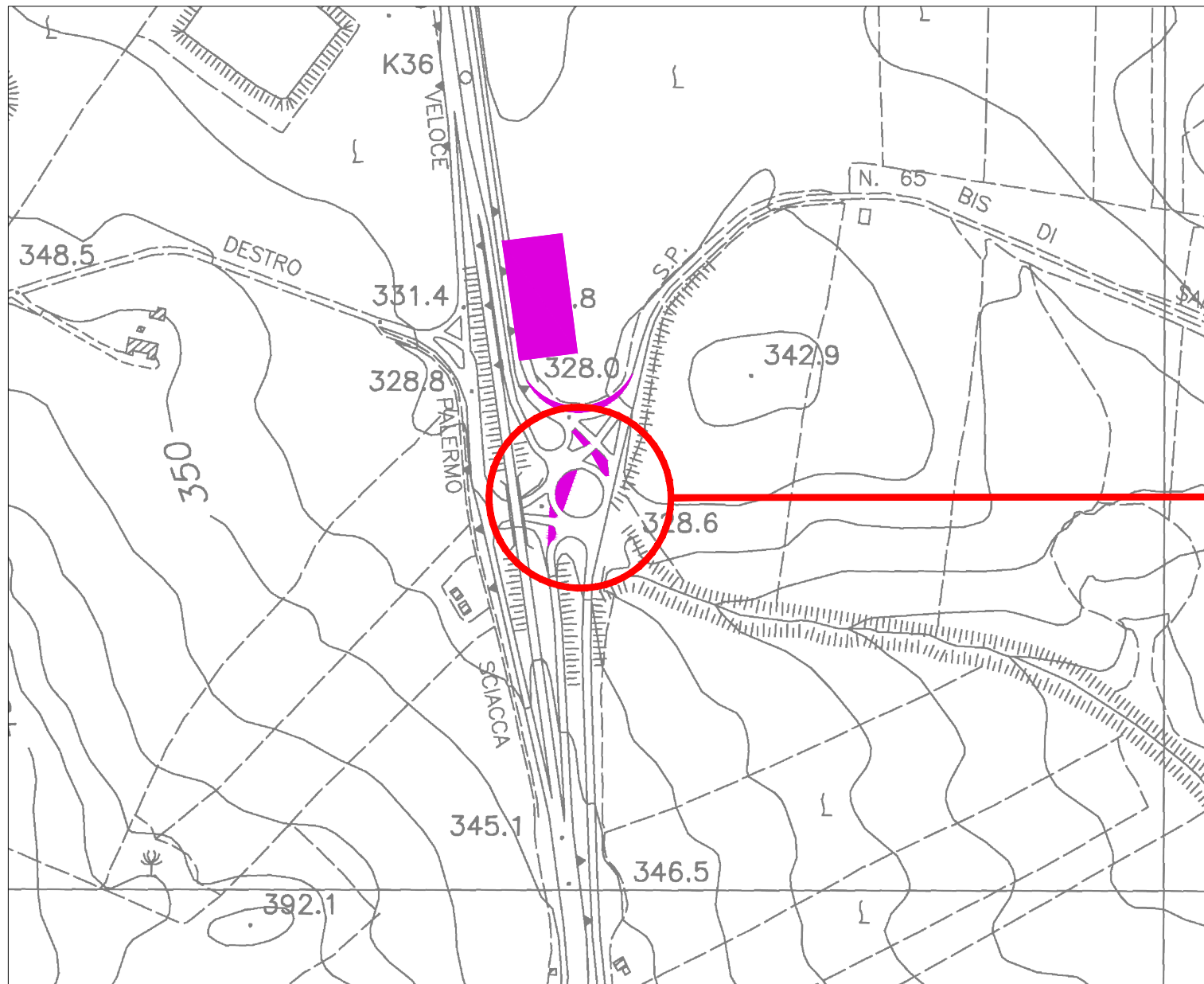

Planimetria catastale - Scala 1:500



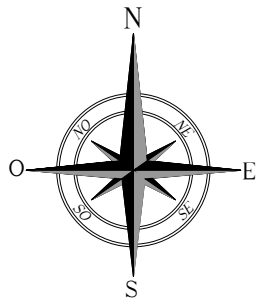

# INTERVENTI DI ADEGAMENTO VIABILITA' ESTERNA DI ACCESSO AL PARCO SU C.T.R. / CATASTALE





INT. 05

Comune di Monreale F.M. 164 - F.M. 144 p.lla 180

STRADA PROVINCIALE n.27

lat. 37.882668°N long. 13.152268°E

## LEGENDA

-  VIABILITA' ESISTENTE
-  AREA OCCUPAZIONE REVERSIBILE DI CANTIERE
-  AREA OCCUPAZIONE REVERSIBILE DI ESERCIZIO
-  AREA OCCUPAZIONE IRREVERSIBILE
-  CONFINE COMUNALE

Corografia – Scala 1:5.000

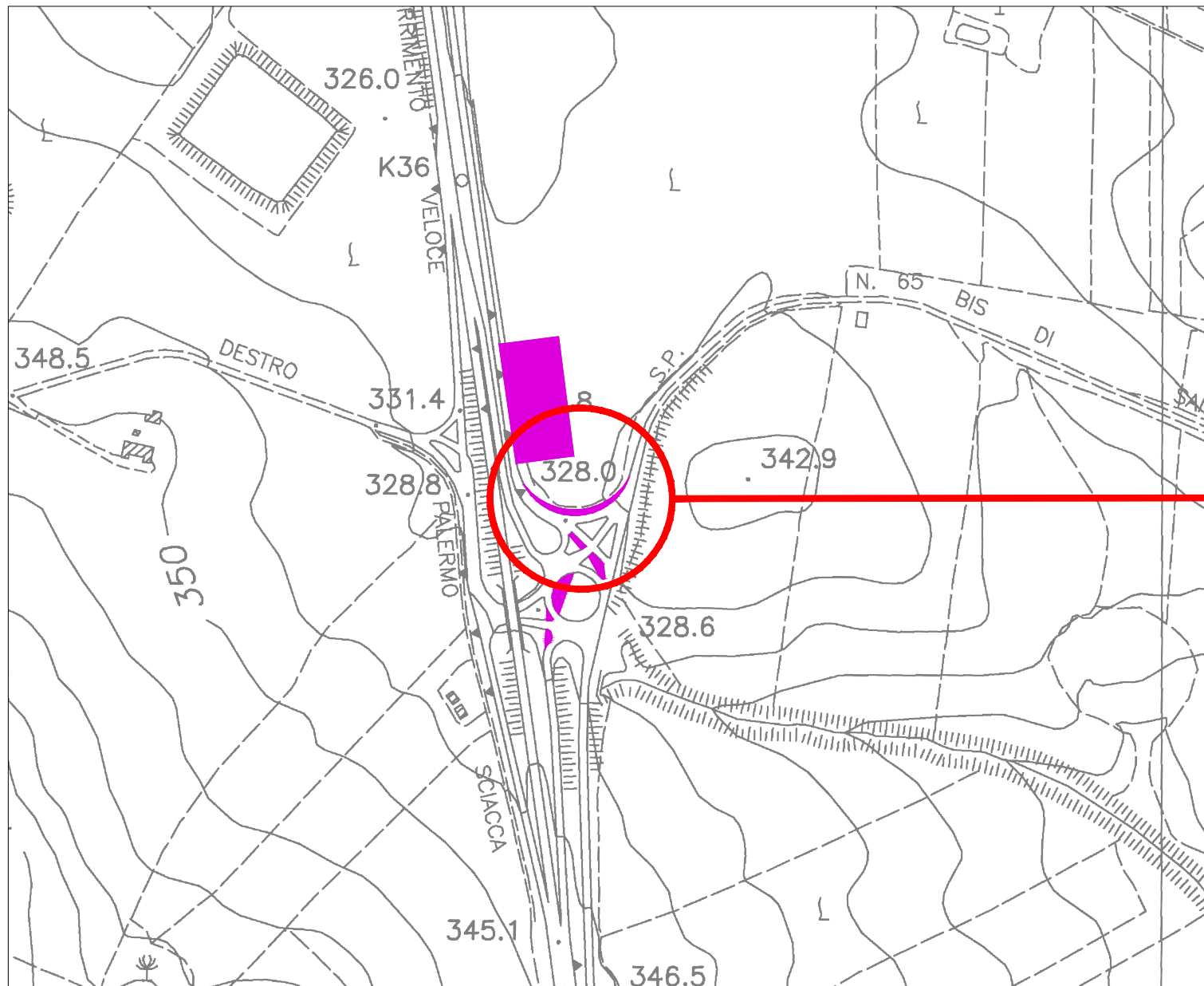

Planimetria catastale - Scala 1:500

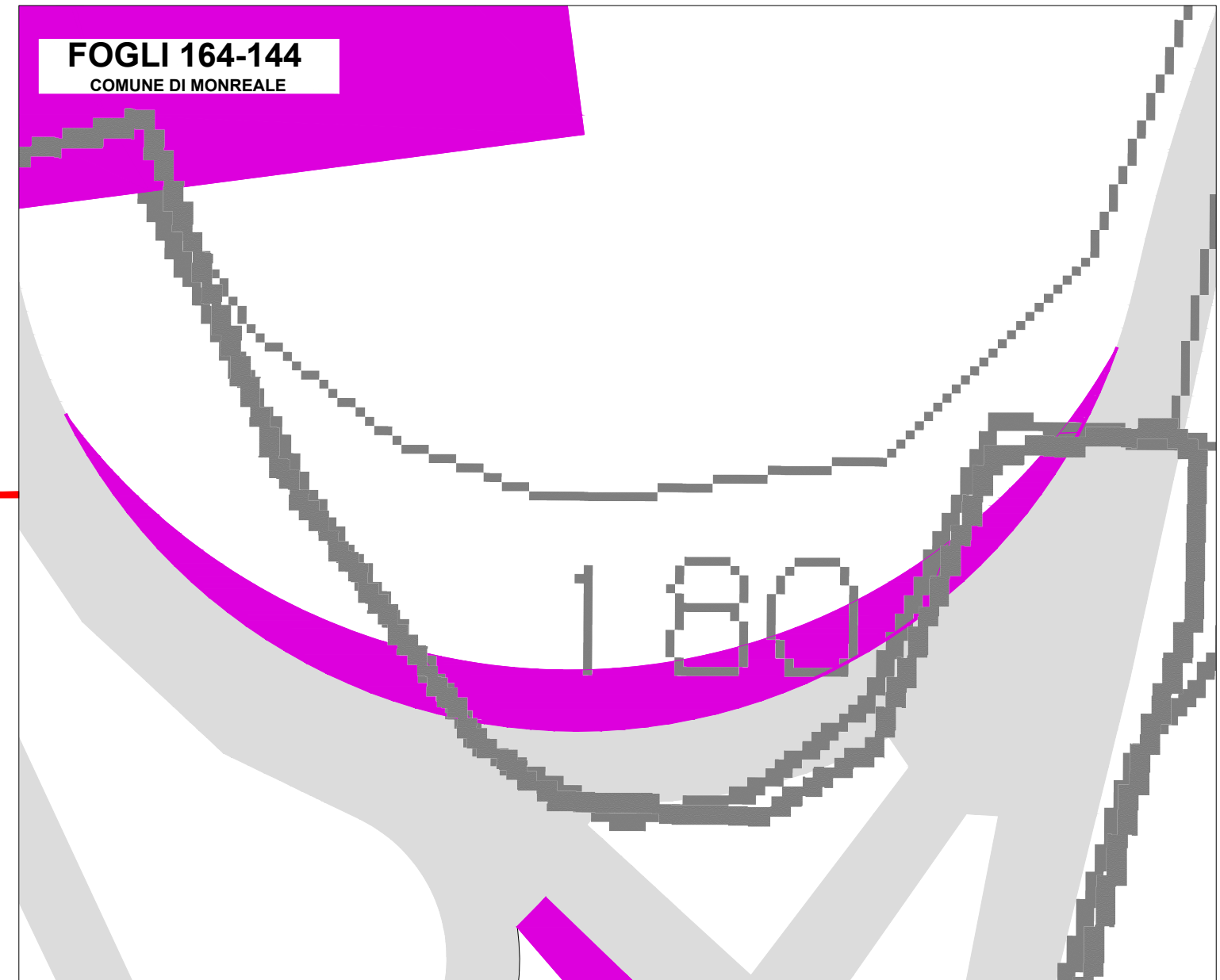

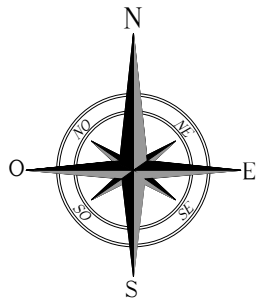

# INTERVENTI DI ADEGAMENTO VIABILITA' ESTERNA DI ACCESSO AL PARCO SU C.T.R. / CATASTALE





INT. 06

Comune di Monreale F.M. 164 -F.M. 143 - F.M. 144 p.lla 179

STRADA PROVINCIALE n.27

lat. 37.883966°N long. 13.151707°E

**LEGENDA**

-  VIABILITA' ESISTENTE
-  AREA OCCUPAZIONE REVERSIBILE DI CANTIERE
-  AREA OCCUPAZIONE REVERSIBILE DI ESERCIZIO
-  AREA OCCUPAZIONE IRREVERSIBILE
-  CONFINE COMUNALE

Corografia – Scala 1:5.000

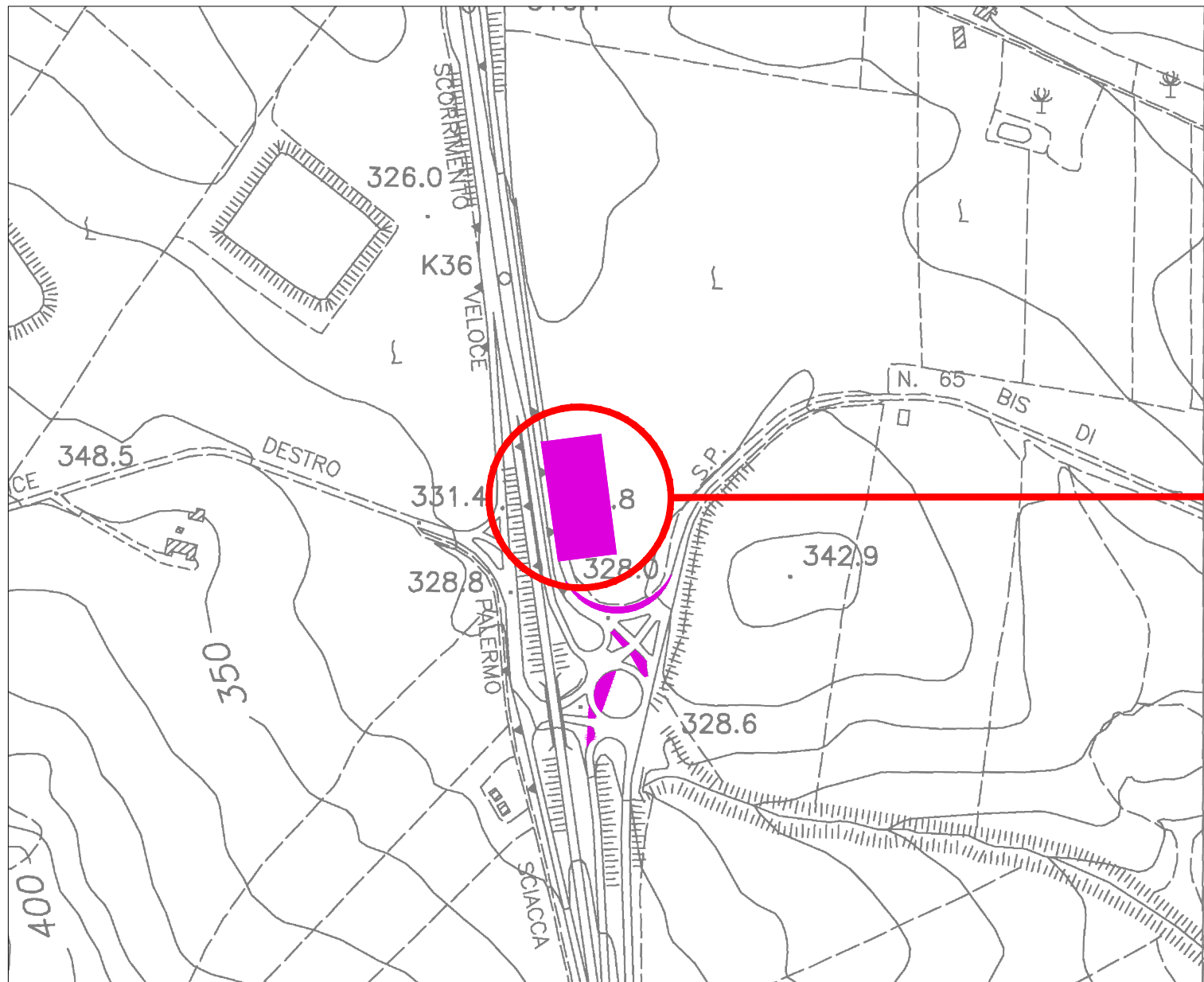

Planimetria catastale - Scala 1:1.000

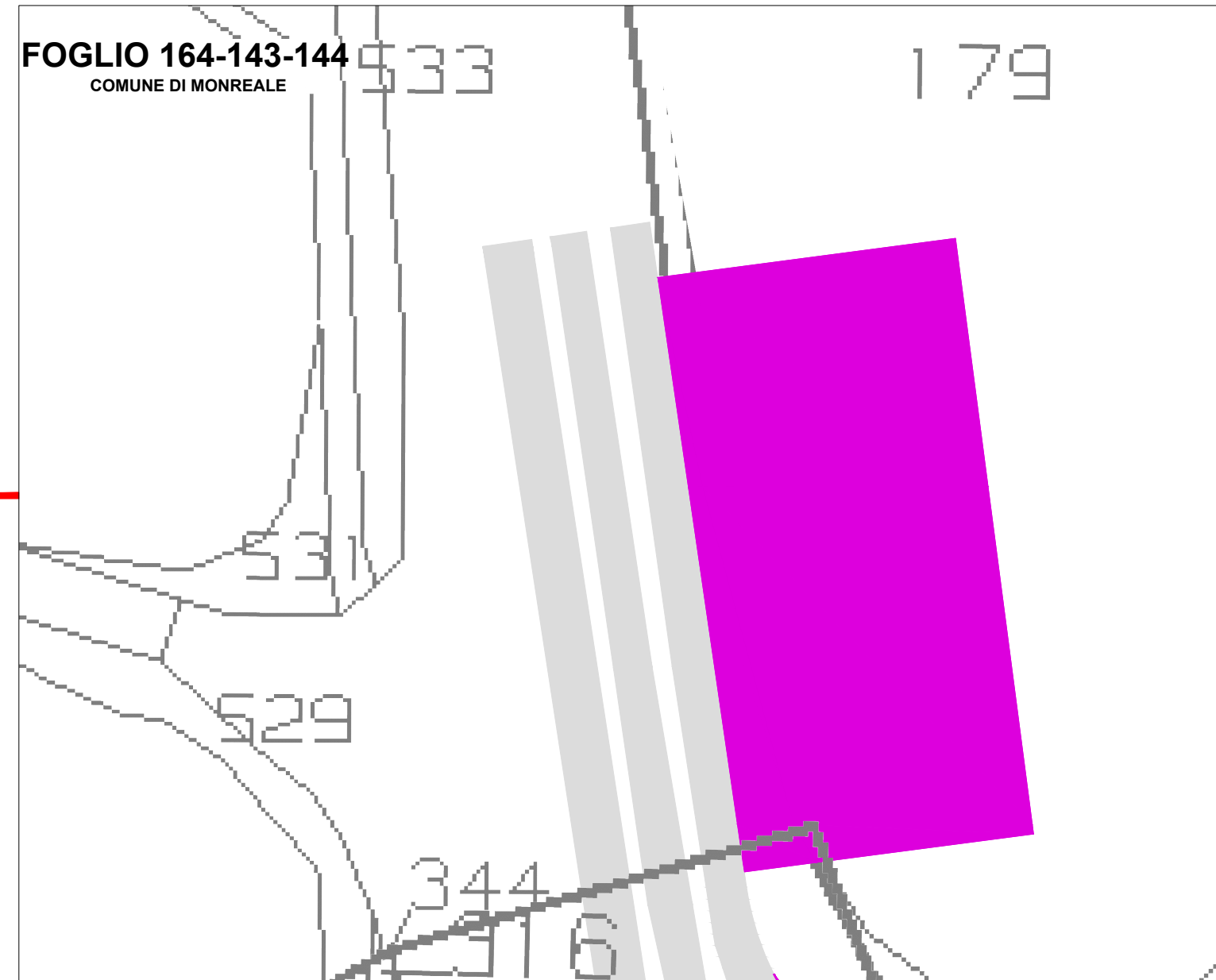

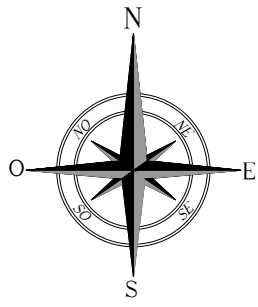

# INTERVENTI DI ADEGAMENTO VIABILITA' ESTERNA DI ACCESSO AL PARCO SU C.T.R. / CATASTALE





INT. 07

Comune di Monreale F.M. 164

STRADA PROVINCIALE n.27

lat. 37.882415°N long. 13.152364°E

**LEGENDA**

-  VIABILITA' ESISTENTE
-  AREA OCCUPAZIONE REVERSIBILE DI CANTIERE
-  AREA OCCUPAZIONE REVERSIBILE DI ESERCIZIO
-  AREA OCCUPAZIONE IRREVERSIBILE
-  CONFINE COMUNALE

Corografia – Scala 1:5.000

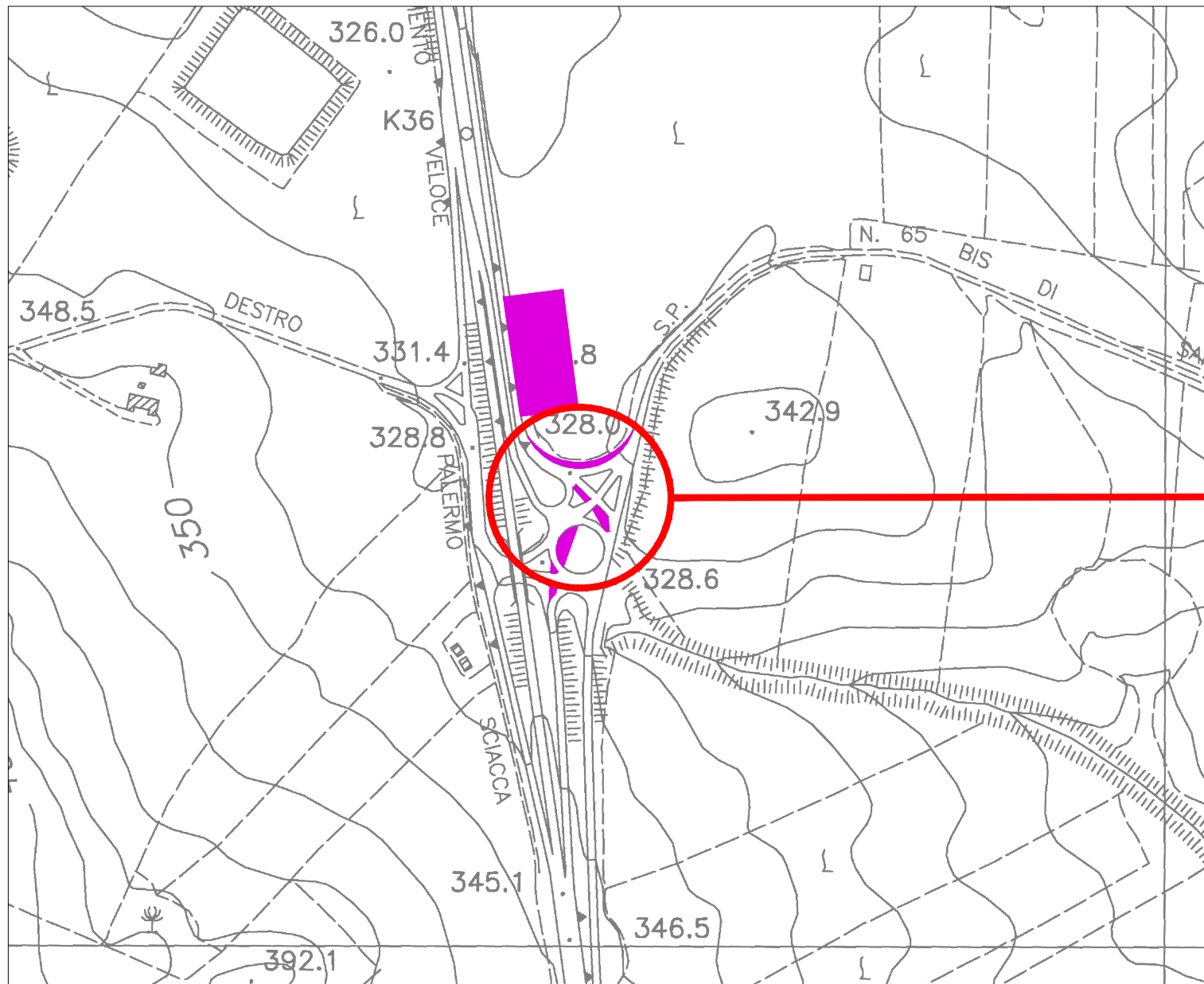

Planimetria catastale - Scala 1:1.000

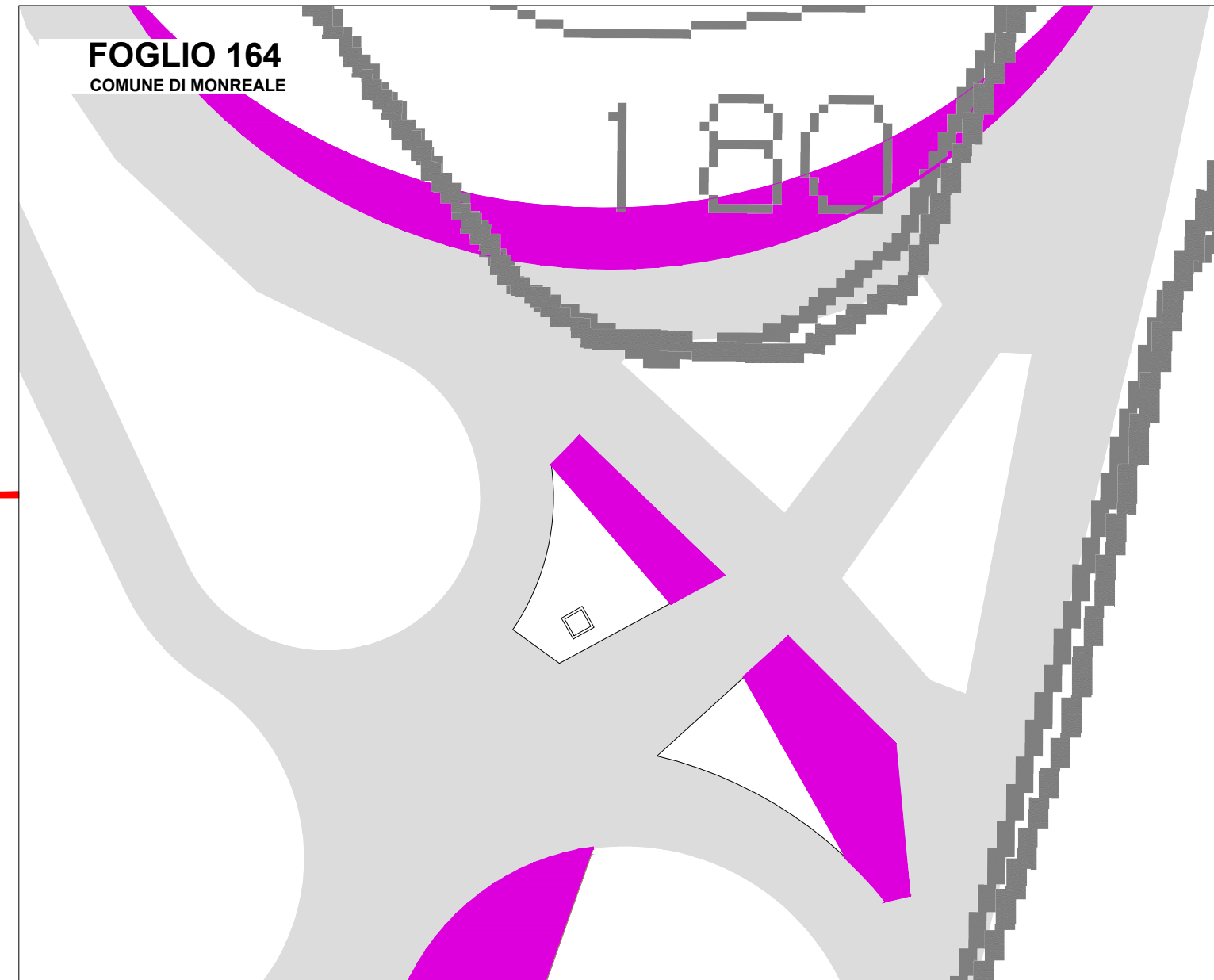

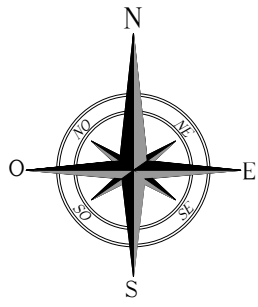

# INTERVENTI DI ADEGAMENTO VIABILITA' ESTERNA DI ACCESSO AL PARCO SU C.T.R. / CATASTALE





INT. 08

Comune di Monreale F.M. 164

STRADA PROVINCIALE n.27

lat. 37.882249°N long. 13.152559°E

**LEGENDA**

-  VIABILITA' ESISTENTE
-  AREA OCCUPAZIONE REVERSIBILE DI CANTIERE
-  AREA OCCUPAZIONE REVERSIBILE DI ESERCIZIO
-  AREA OCCUPAZIONE IRREVERSIBILE
-  CONFINE COMUNALE

Corografia – Scala 1:5.000

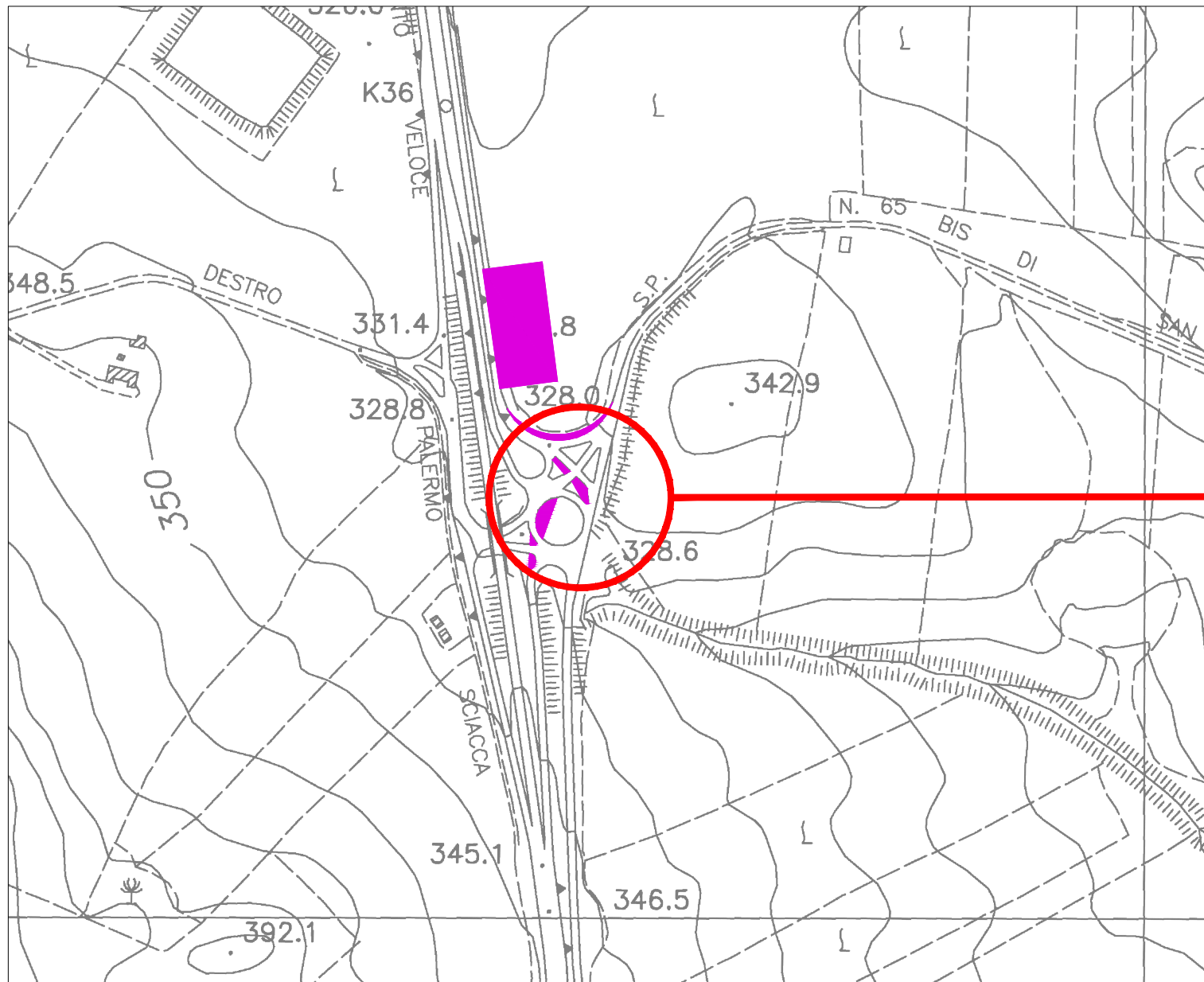

Planimetria catastale - Scala 1:1.000

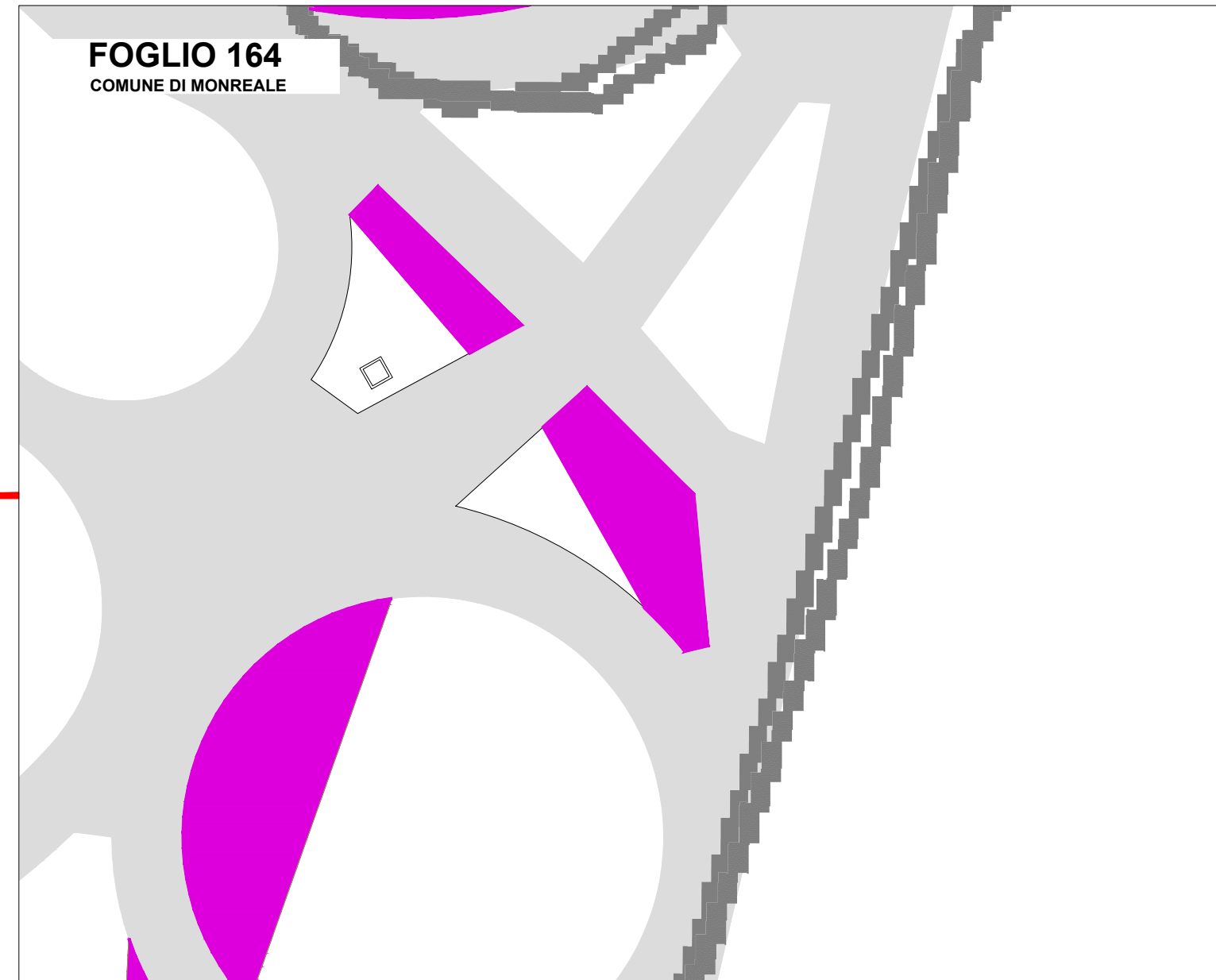



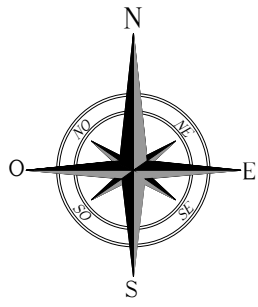

# INTERVENTI DI ADEGAMENTO VIABILITA' ESTERNA DI ACCESSO AL PARCO SU C.T.R. / CATASTALE





INT. 09

Comune di Monreale F.M. 164 p.lla 102

STRADA PROVINCIALE n.27

lat. 37.877637°N long. 13.152909°E

**LEGENDA**

-  VIABILITA' ESISTENTE
-  AREA OCCUPAZIONE REVERSIBILE DI CANTIERE
-  AREA OCCUPAZIONE REVERSIBILE DI ESERCIZIO
-  AREA OCCUPAZIONE IRREVERSIBILE
-  CONFINE COMUNALE

Corografia – Scala 1:5.000

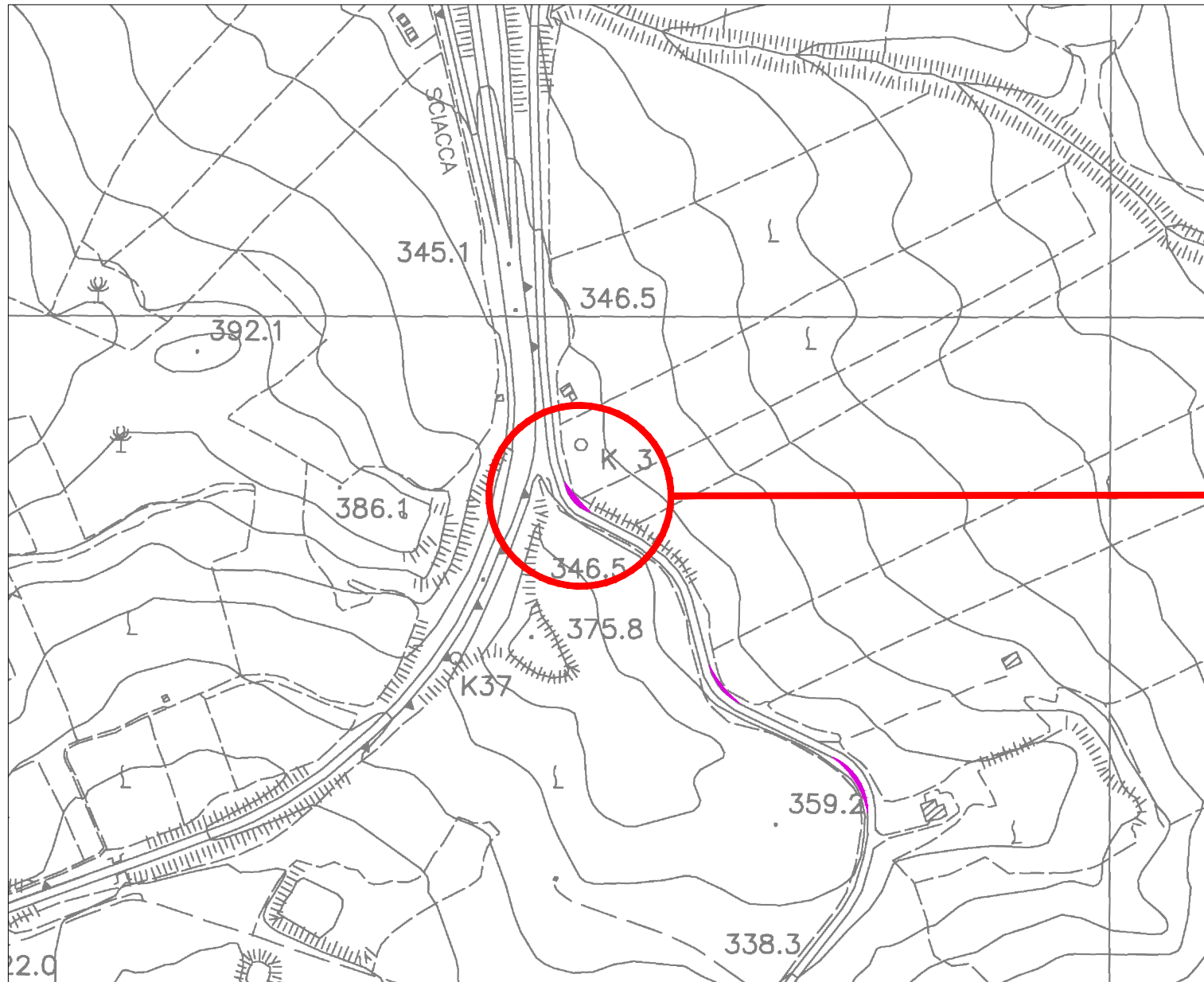

Planimetria catastale - Scala 1:1.000

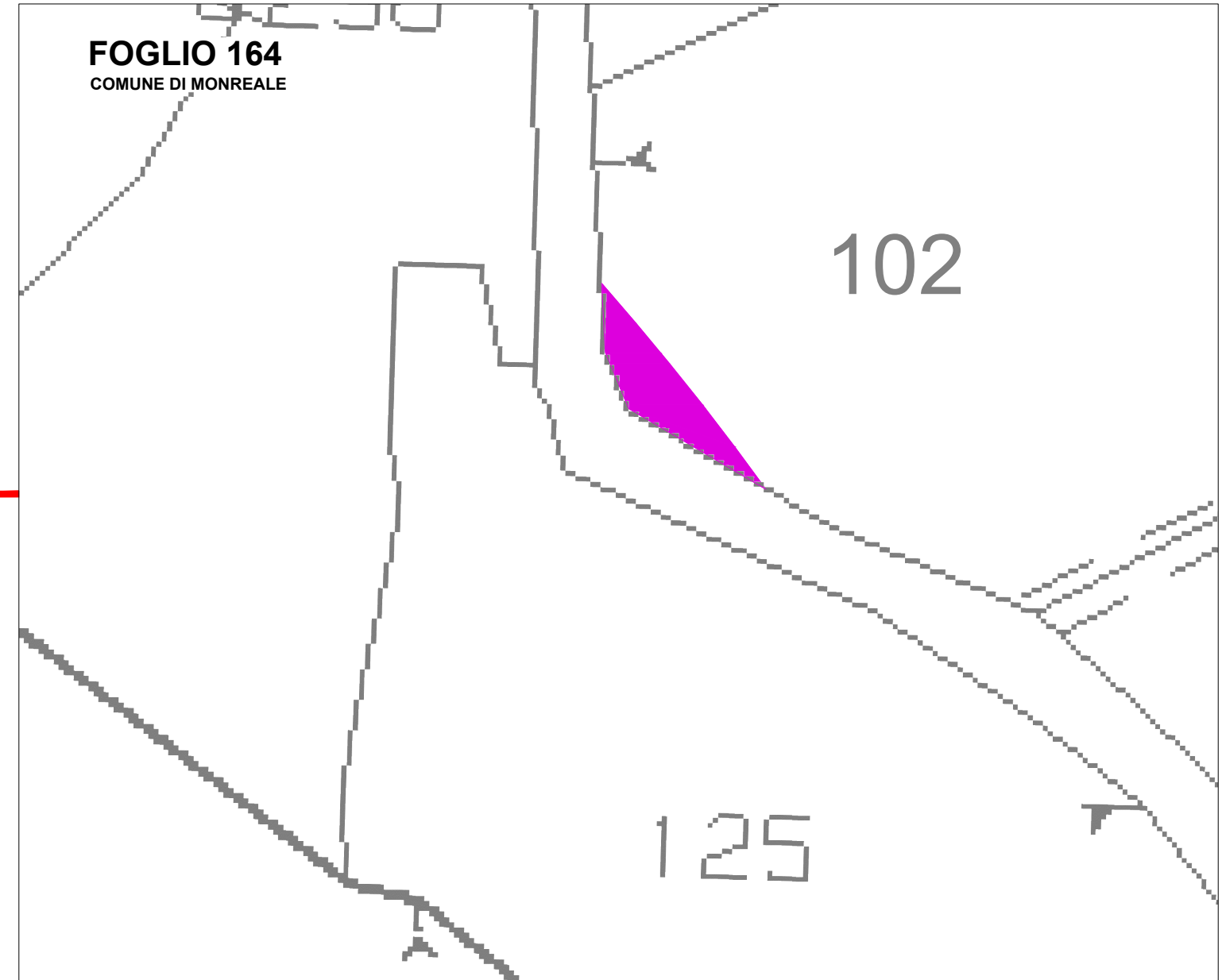

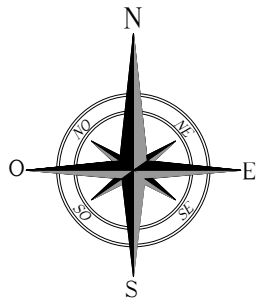

# INTERVENTI DI ADEGAMENTO VIABILITA' ESTERNA DI ACCESSO AL PARCO SU C.T.R. / CATASTALE





INT. 10

Comune di Monreale F.M. 164 p.lla 105

STRADA PROVINCIALE n.27

lat. 37.876274°N long. 13.154342°E

**LEGENDA**

-  VIABILITA' ESISTENTE
-  AREA OCCUPAZIONE REVERSIBILE DI CANTIERE
-  AREA OCCUPAZIONE REVERSIBILE DI ESERCIZIO
-  AREA OCCUPAZIONE IRREVERSIBILE
-  CONFINE COMUNALE

Corografia – Scala 1:5.000

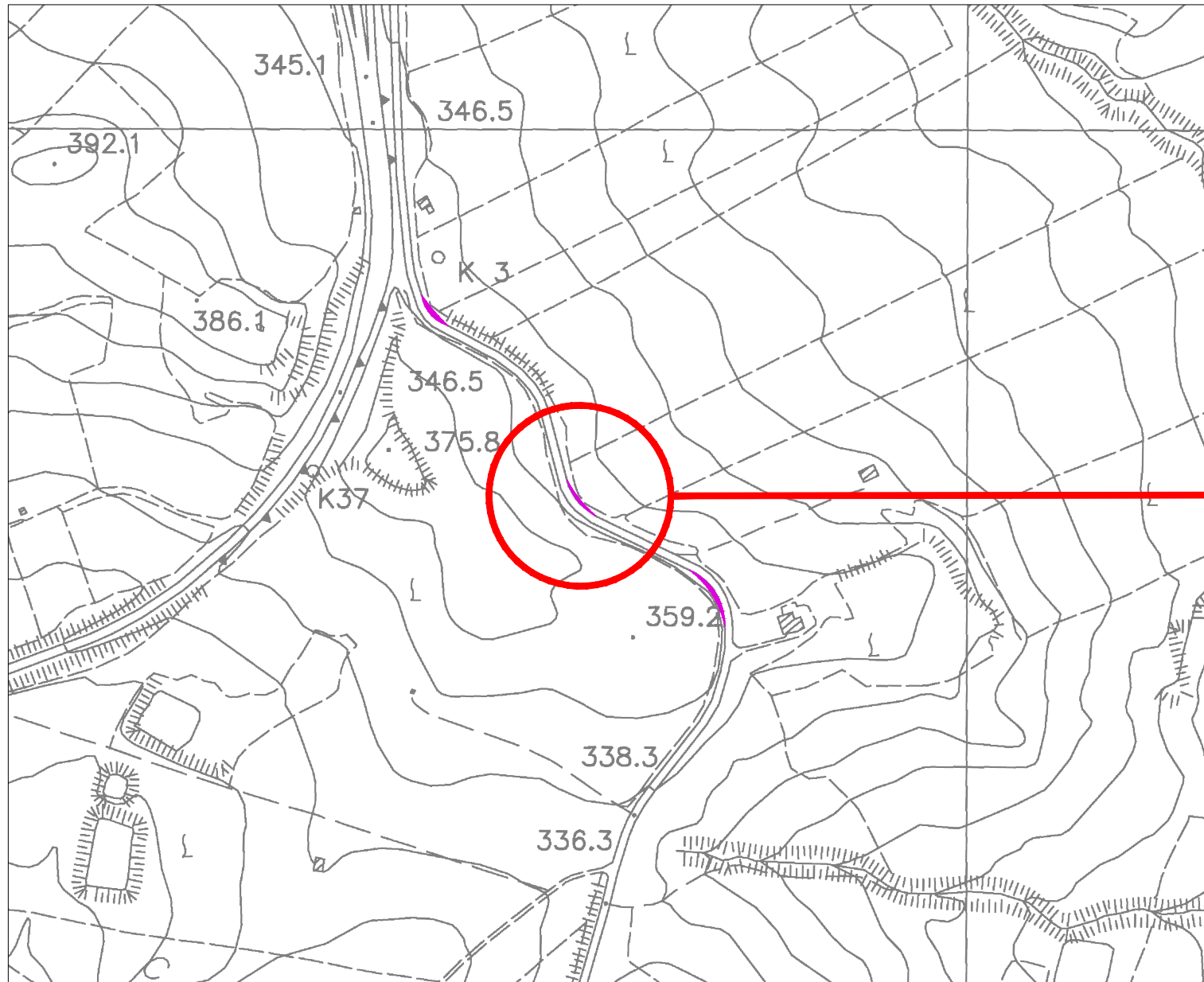

Planimetria catastale - Scala 1:1.000

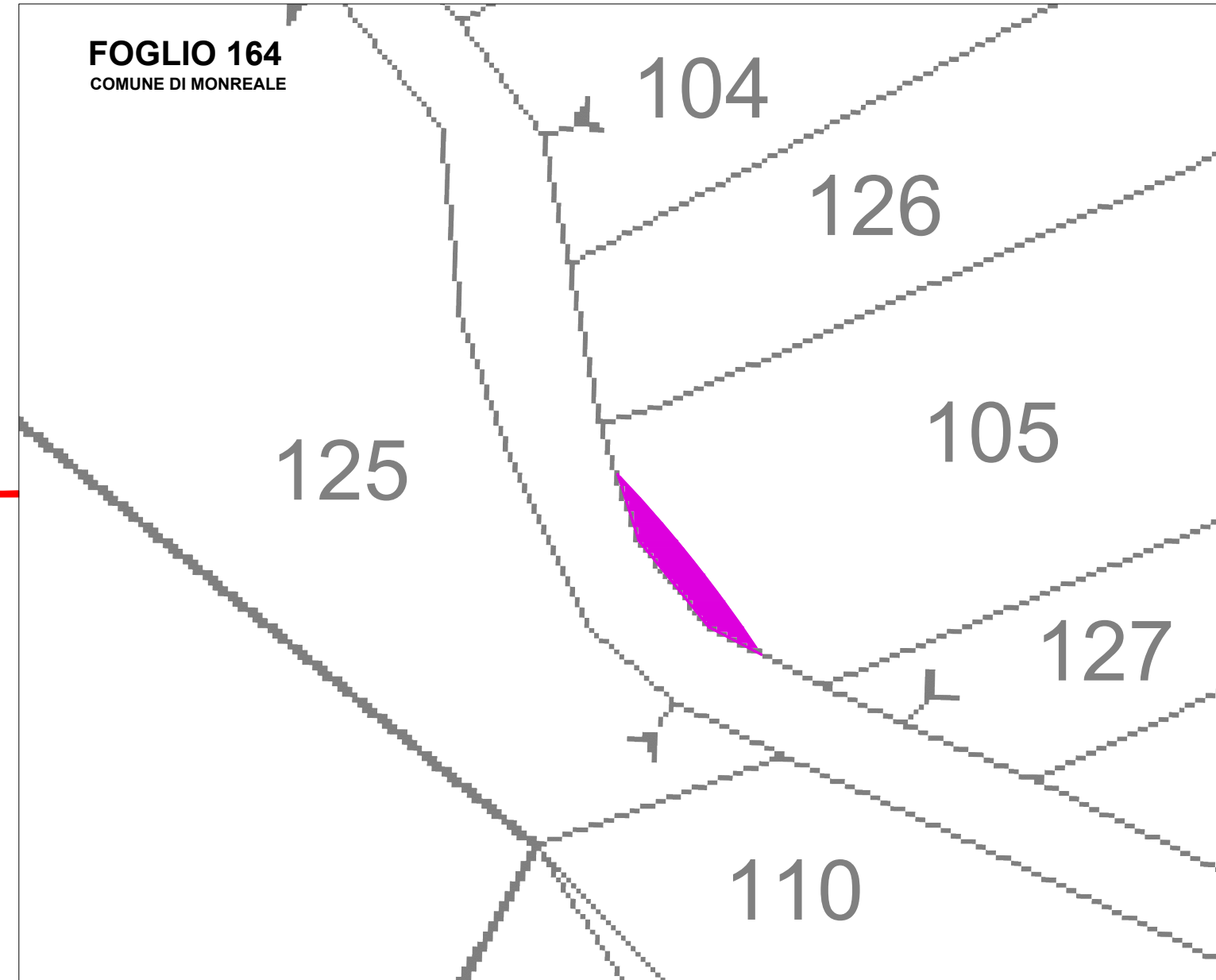

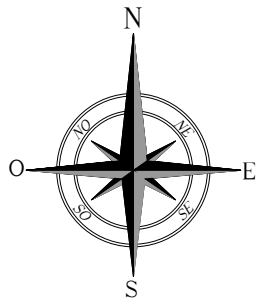

# INTERVENTI DI ADEGAMENTO VIABILITA' ESTERNA DI ACCESSO AL PARCO SU C.T.R. / CATASTALE





INT. 11

Comune di Monreale F.M. 164 p.lla 110

STRADA PROVINCIALE n.27

lat. 37.875439°N long. 13.155701°E

**LEGENDA**

-  VIABILITA' ESISTENTE
-  AREA OCCUPAZIONE REVERSIBILE DI CANTIERE
-  AREA OCCUPAZIONE REVERSIBILE DI ESERCIZIO
-  AREA OCCUPAZIONE IRREVERSIBILE
-  CONFINE COMUNALE

Corografia – Scala 1:5.000

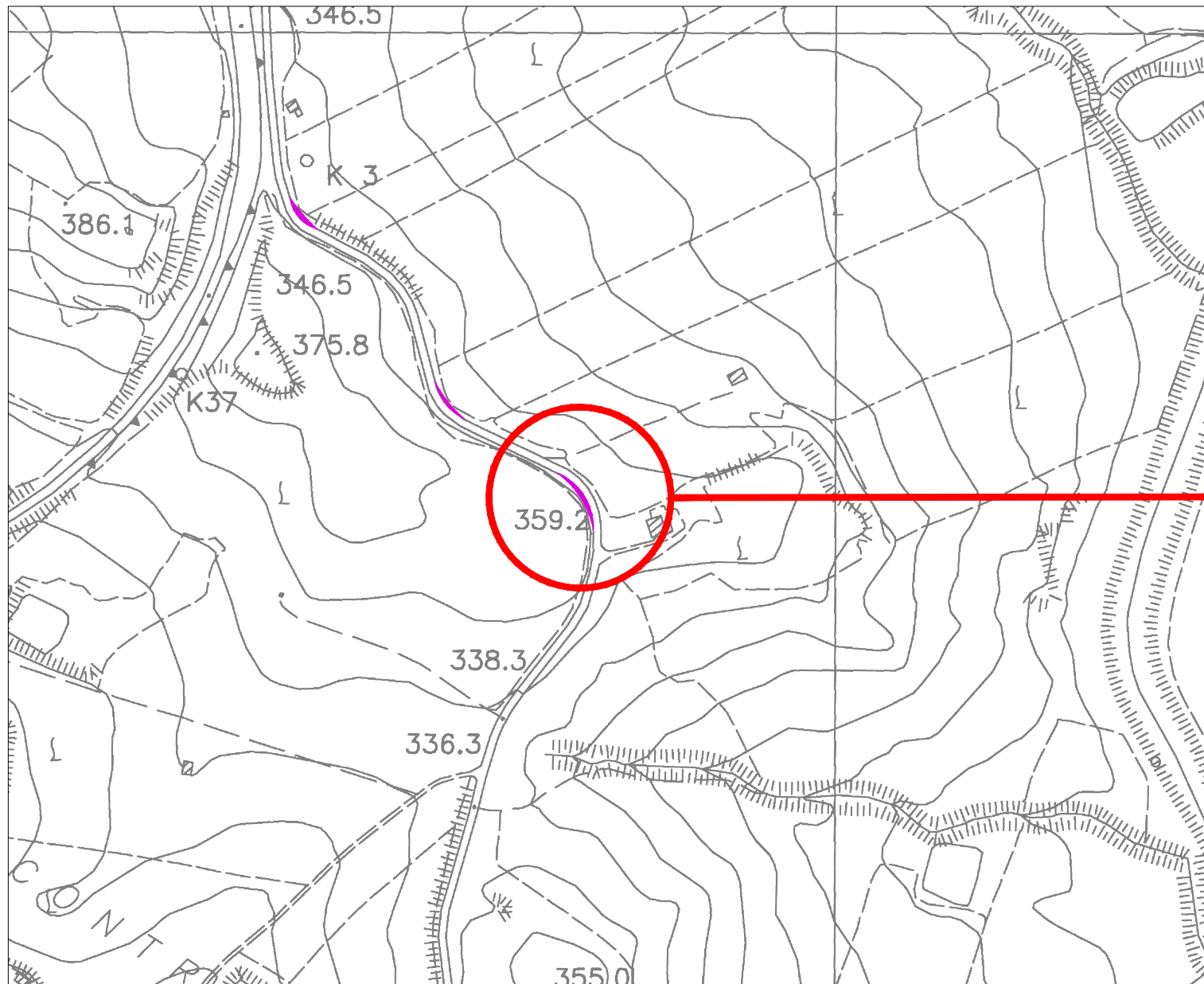

Planimetria catastale - Scala 1:1.000

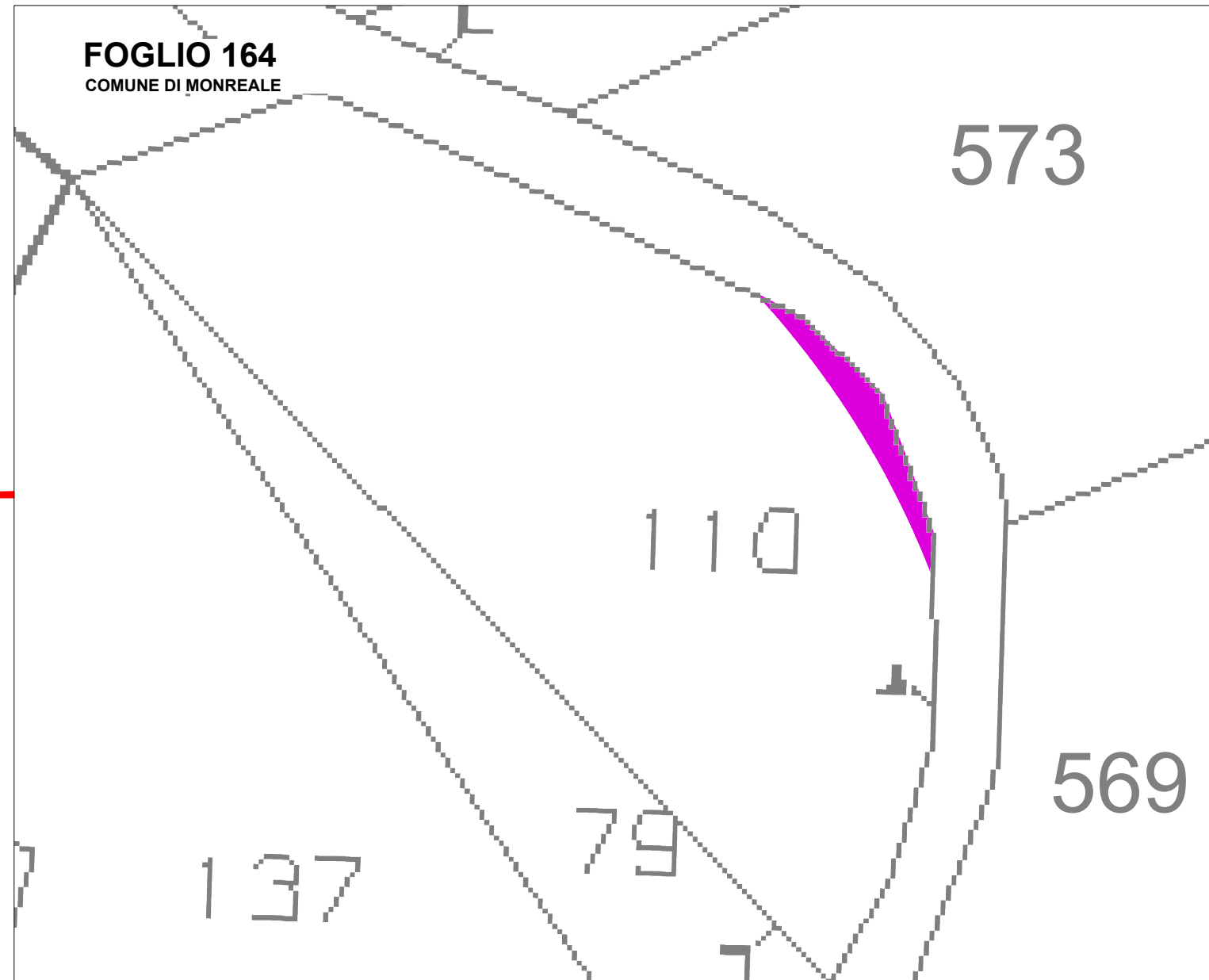

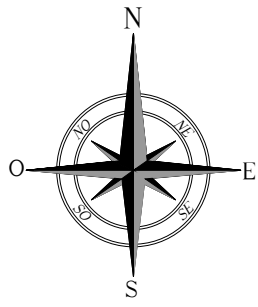

# INTERVENTI DI ADEGAMENTO VIABILITA' ESTERNA DI ACCESSO AL PARCO SU C.T.R. / CATASTALE

INT. 12

Comune di Monreale F.M. 164 p.lla 24, 120, 133

STRADA PROVINCIALE n.27

lat. 37.865541°N long. 13.156039°E

**LEGENDA**

- VIABILITA' ESISTENTE
- AREA OCCUPAZIONE REVERSIBILE DI CANTIERE
- AREA OCCUPAZIONE REVERSIBILE DI ESERCIZIO
- AREA OCCUPAZIONE IRREVERSIBILE
- CONFINE COMUNALE

Corografia – Scala 1:5.000

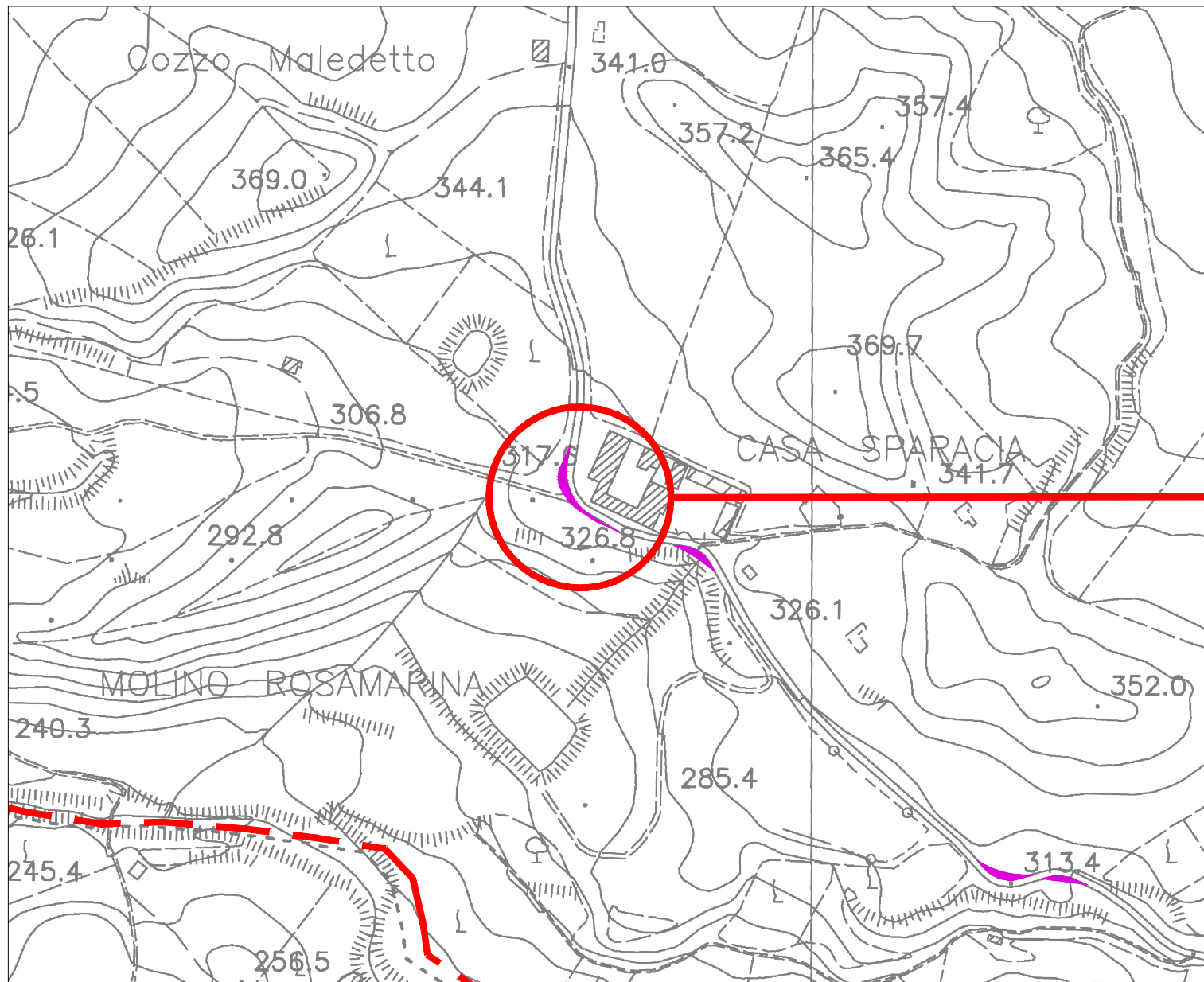

Planimetria catastale - Scala 1:1.000

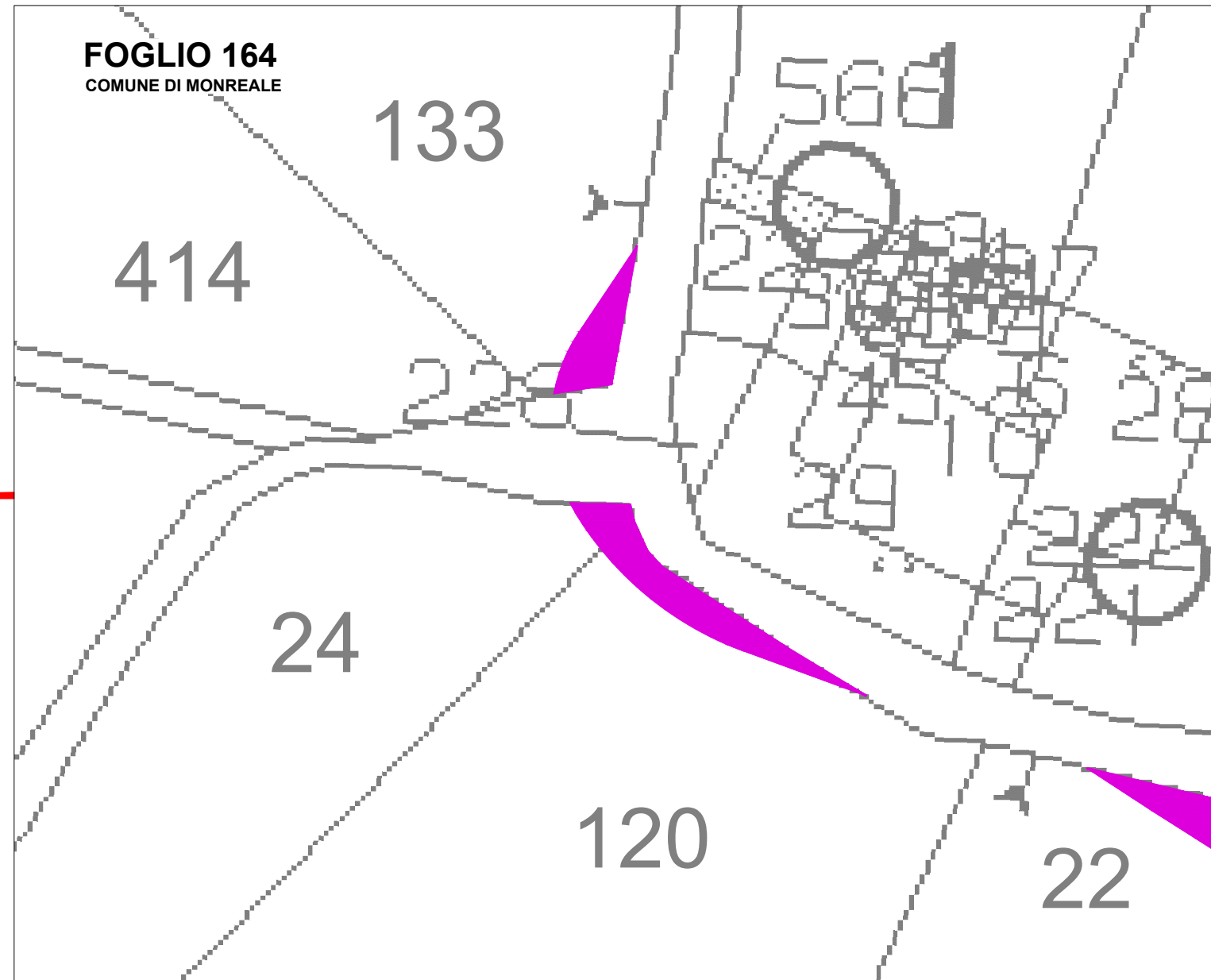

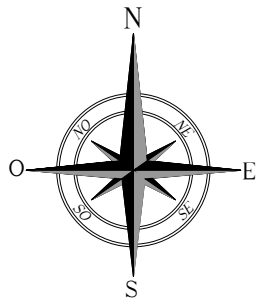

# INTERVENTI DI ADEGAMENTO VIABILITA' ESTERNA DI ACCESSO AL PARCO SU C.T.R. / CATASTALE





INT. 13

Comune di Monreale F.M. 164 p.lla 22

STRADA PROVINCIALE n.27

lat. 37.865126°N long. 13.157208°E

**LEGENDA**

-  VIABILITA' ESISTENTE
-  AREA OCCUPAZIONE REVERSIBILE DI CANTIERE
-  AREA OCCUPAZIONE REVERSIBILE DI ESERCIZIO
-  AREA OCCUPAZIONE IRREVERSIBILE
-  CONFINE COMUNALE

Corografia – Scala 1:5.000

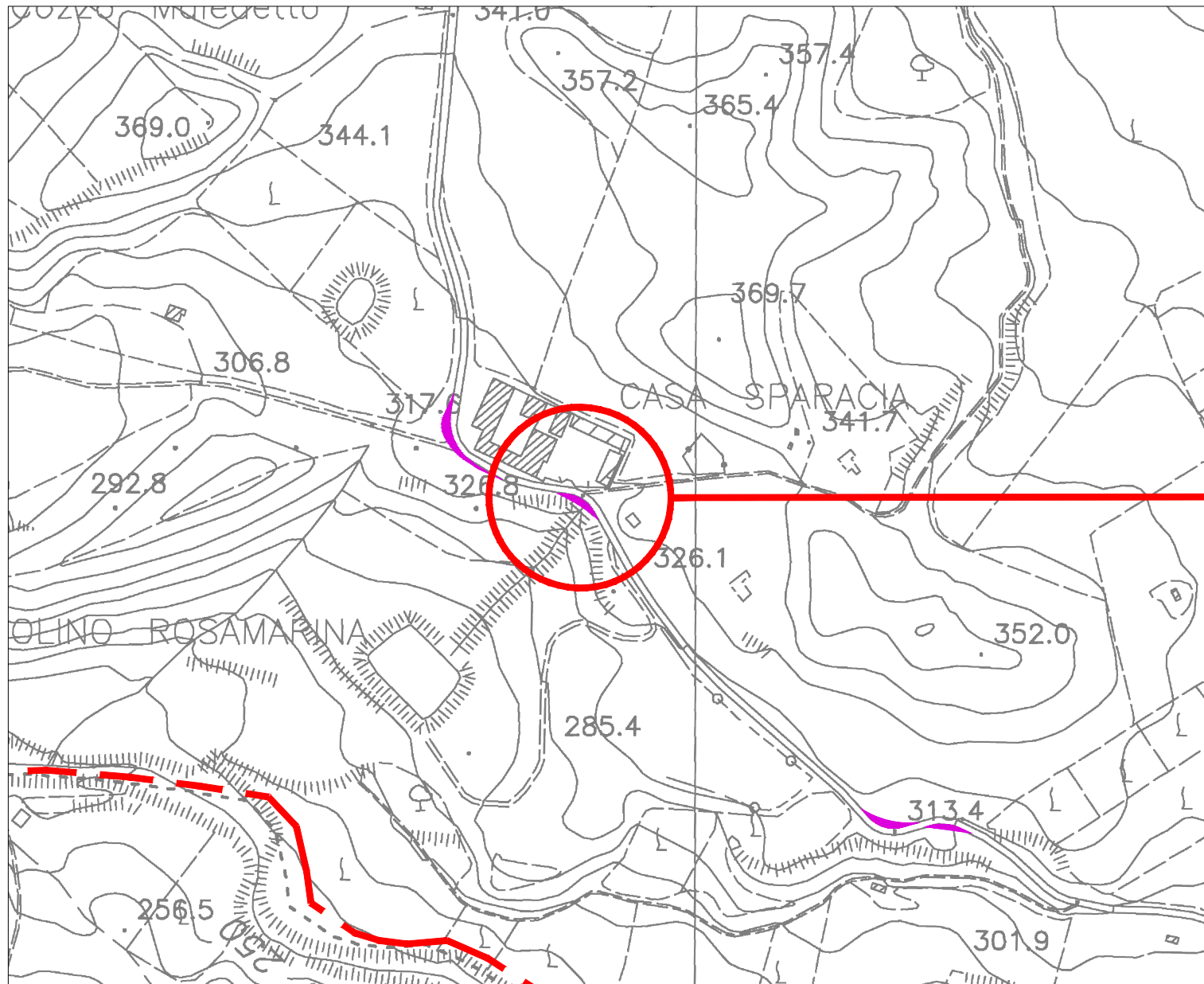

Planimetria catastale - Scala 1:1.000

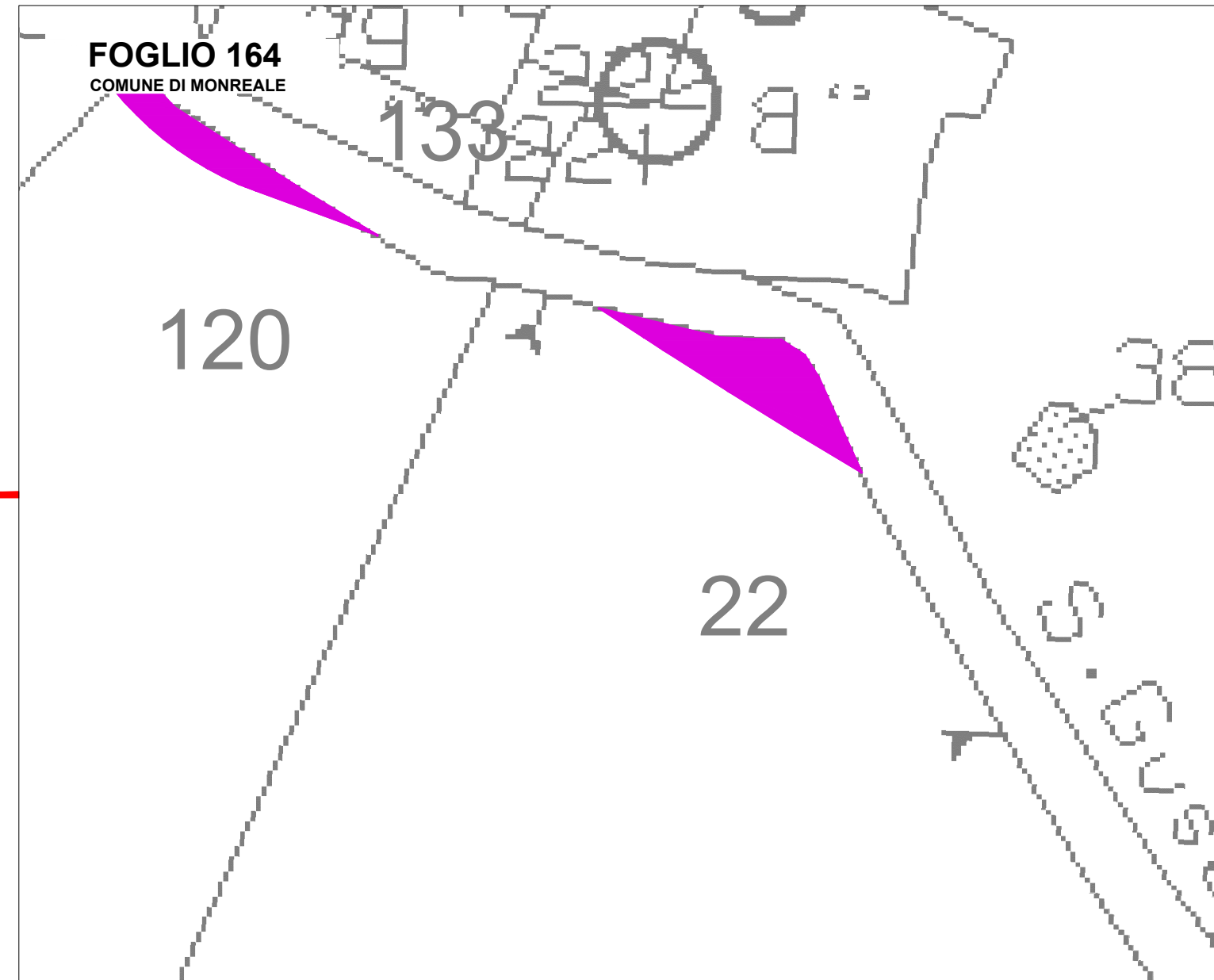

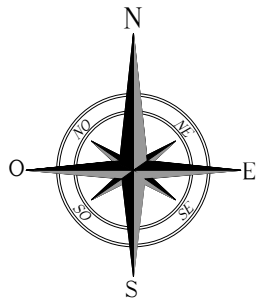

# INTERVENTI DI ADEGAMENTO VIABILITA' ESTERNA DI ACCESSO AL PARCO SU C.T.R. / CATASTALE





INT. 14

Comune di Monreale F.M. 164 p.lla 123

STRADA PROVINCIALE n.27

lat. 37.862801°N long. 13.160085°E

**LEGENDA**

-  VIABILITA' ESISTENTE
-  AREA OCCUPAZIONE REVERSIBILE DI CANTIERE
-  AREA OCCUPAZIONE REVERSIBILE DI ESERCIZIO
-  AREA OCCUPAZIONE IRREVERSIBILE
-  CONFINE COMUNALE

Corografia – Scala 1:5.000

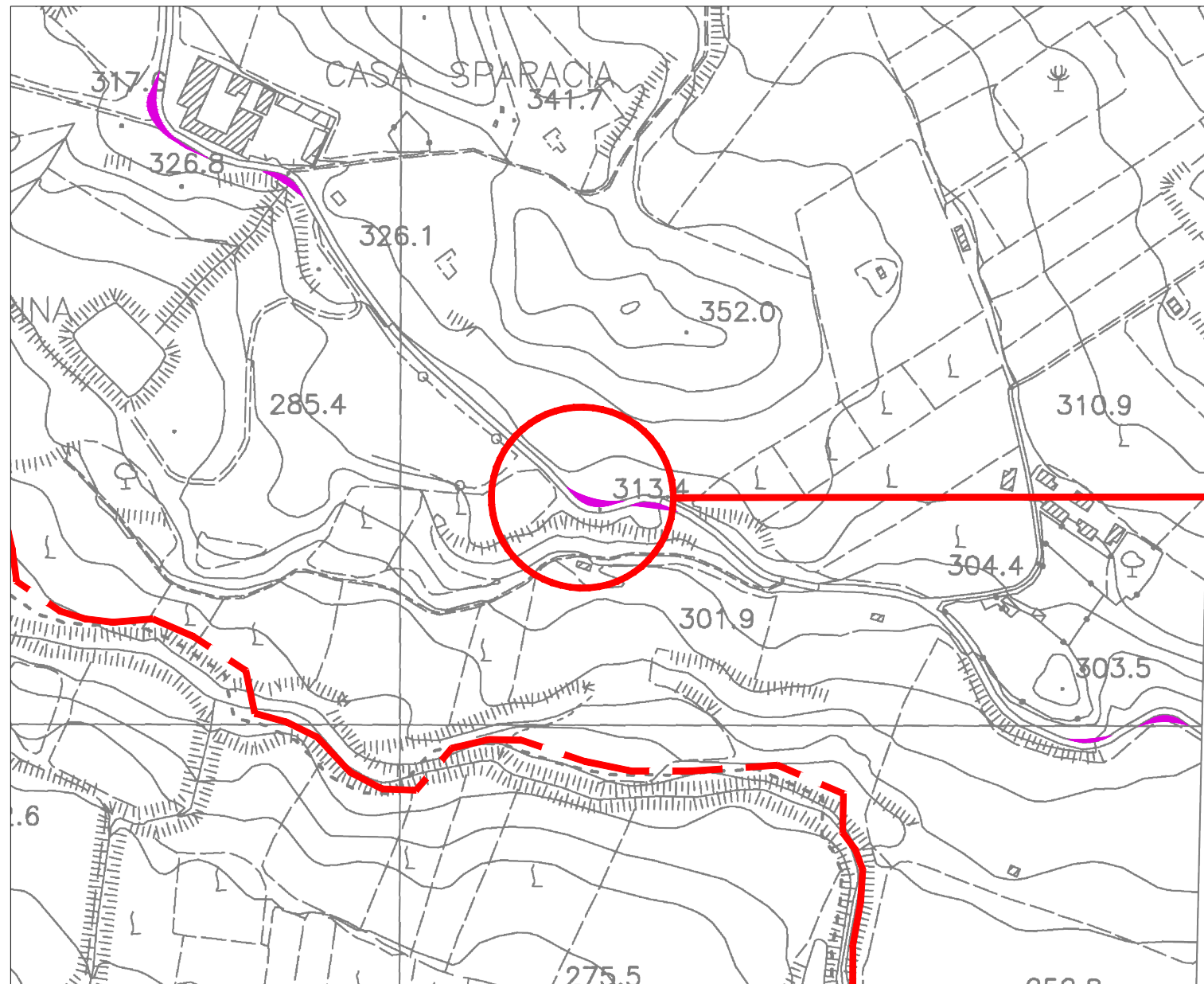

Planimetria catastale - Scala 1:1.000

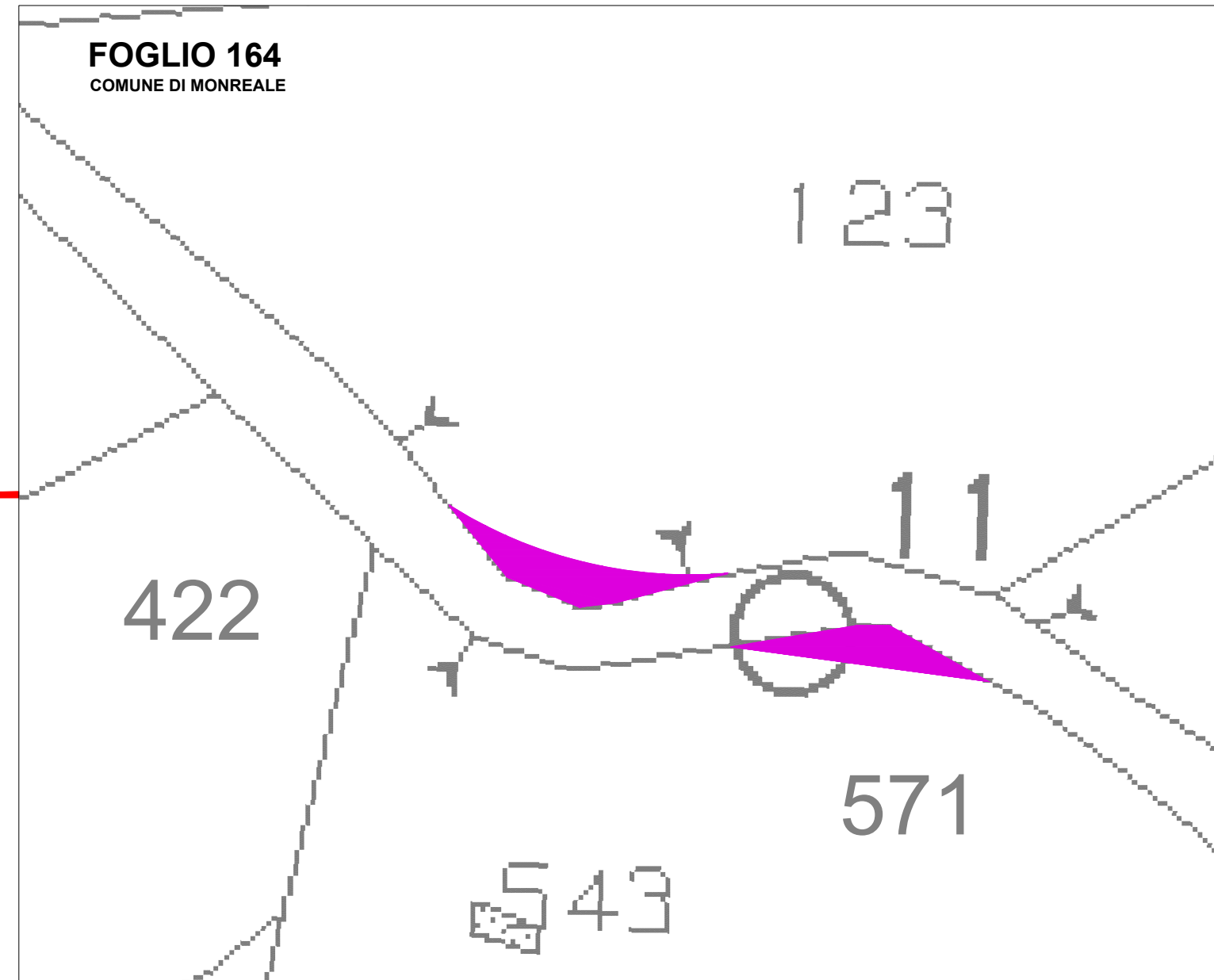

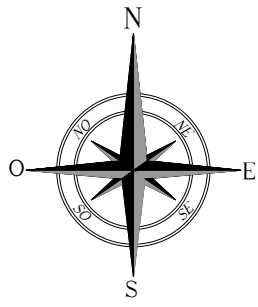

# INTERVENTI DI ADEGAMENTO VIABILITA' ESTERNA DI ACCESSO AL PARCO SU C.T.R. / CATASTALE





INT. 15

Comune di Monreale F.M. 164 p.lla 571

STRADA PROVINCIALE n.27

lat. 37.862722°N long. 13.160804°E

## LEGENDA

-  VIABILITA' ESISTENTE
-  AREA OCCUPAZIONE REVERSIBILE DI CANTIERE
-  AREA OCCUPAZIONE REVERSIBILE DI ESERCIZIO
-  AREA OCCUPAZIONE IRREVERSIBILE
-  CONFINE COMUNALE

Corografia – Scala 1:5.000

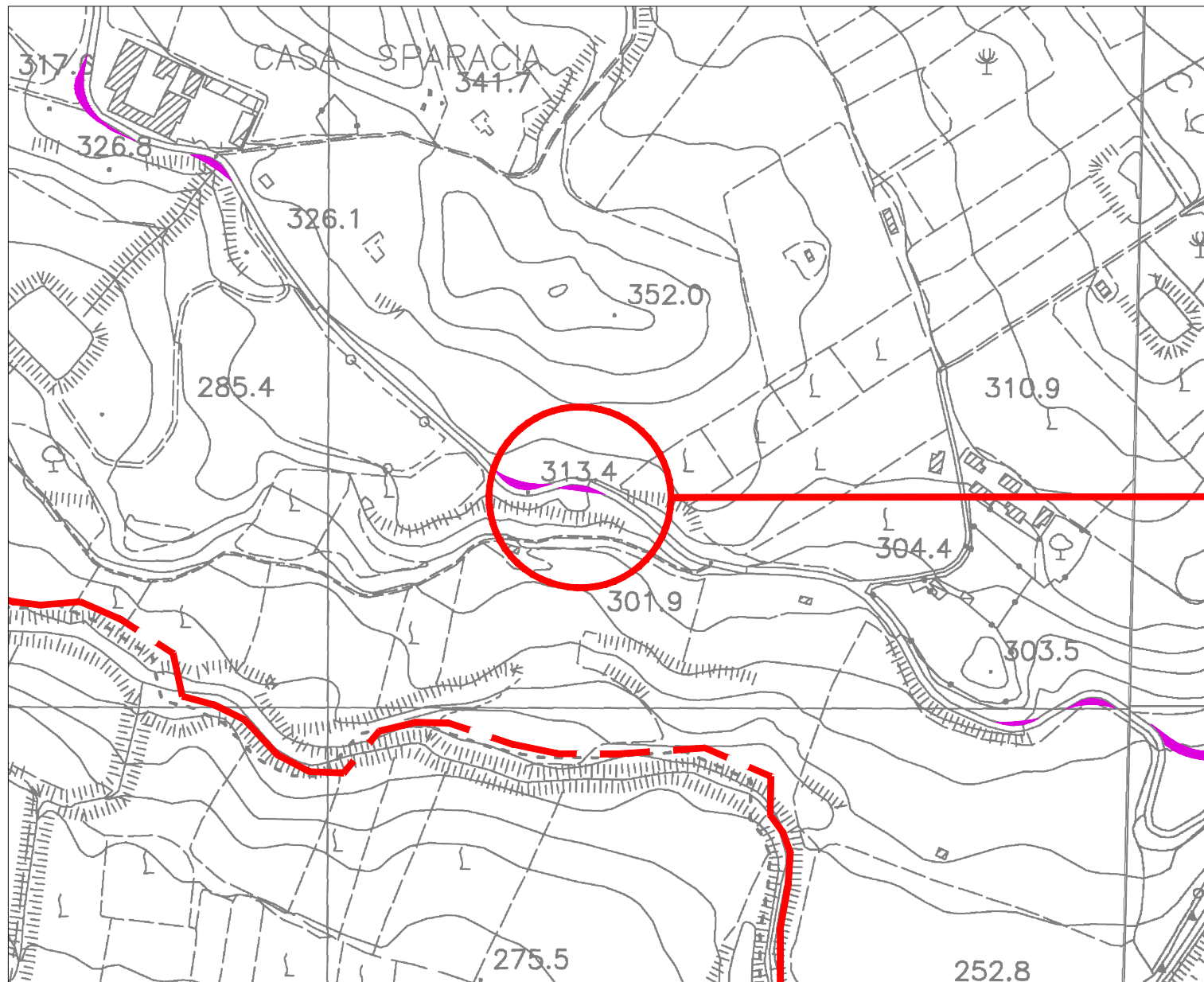

Planimetria catastale - Scala 1:1.000

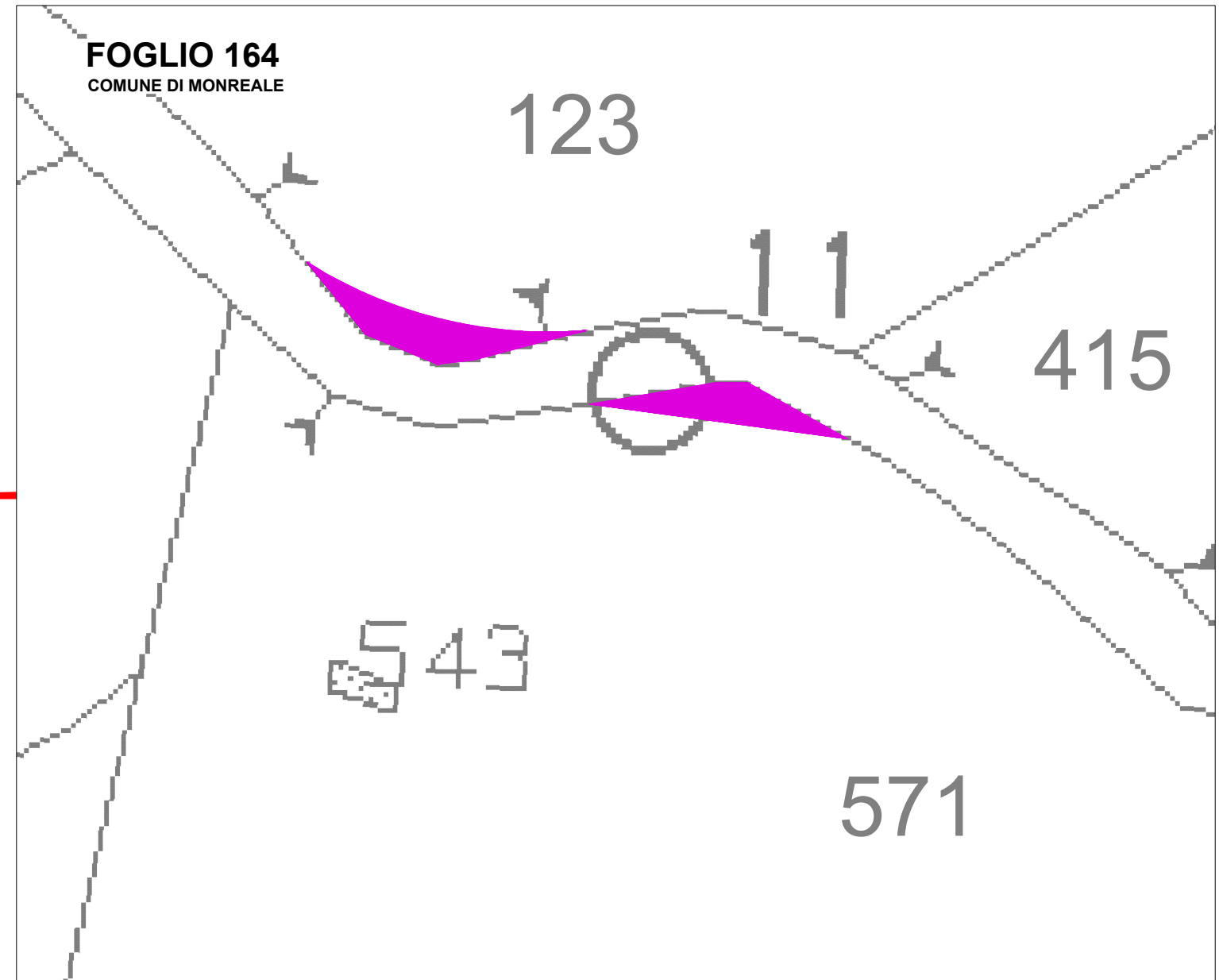

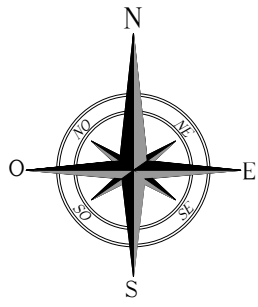

# INTERVENTI DI ADEGAMENTO VIABILITA' ESTERNA DI ACCESSO AL PARCO SU C.T.R. / CATASTALE





INT. 16

Comune di Monreale F.M. 164 p.lla 497

STRADA PROVINCIALE n.27

lat. 37.861092°N long. 13.164879°E

**LEGENDA**

-  VIABILITA' ESISTENTE
-  AREA OCCUPAZIONE REVERSIBILE DI CANTIERE
-  AREA OCCUPAZIONE REVERSIBILE DI ESERCIZIO
-  AREA OCCUPAZIONE IRREVERSIBILE
-  CONFINE COMUNALE

Corografia – Scala 1:5.000

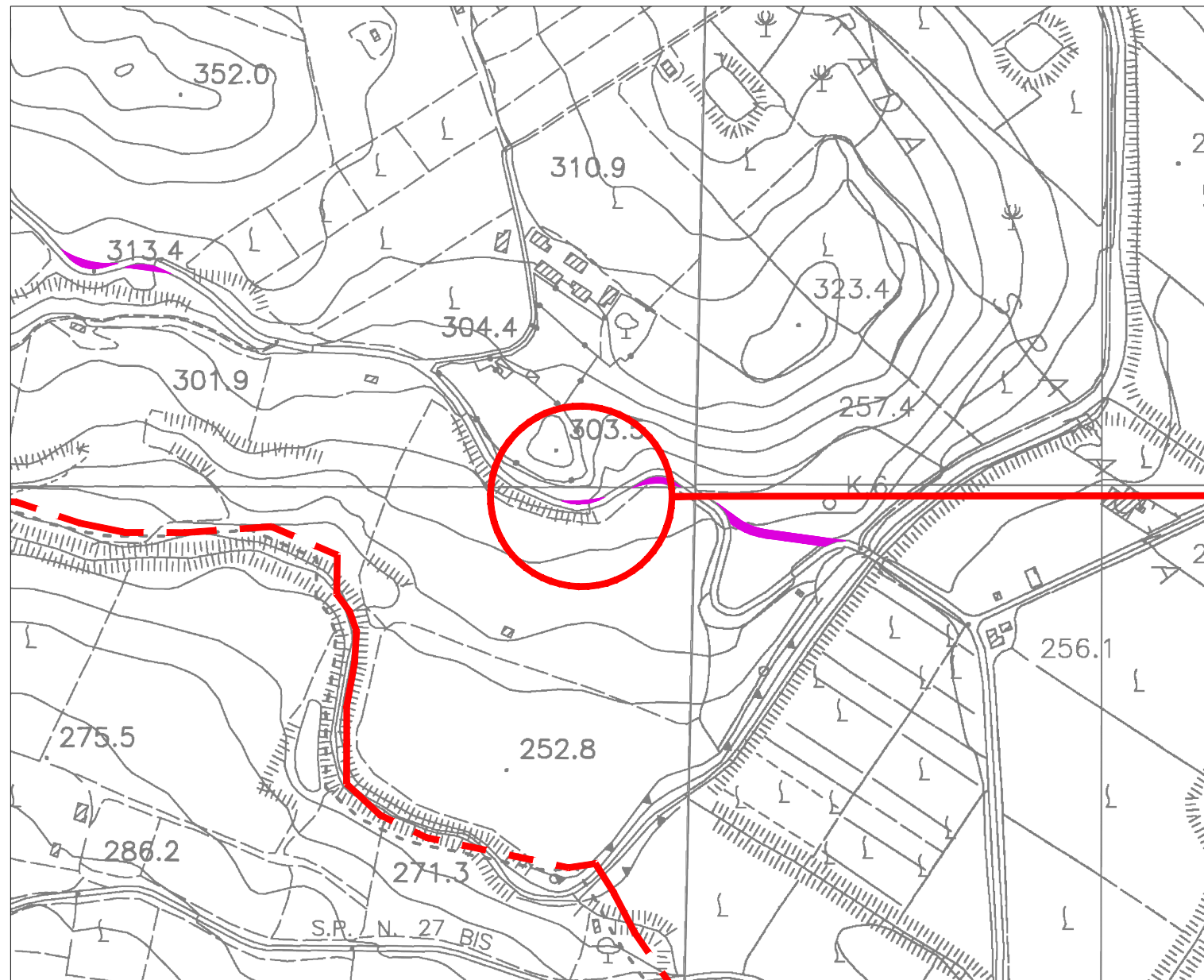

Planimetria catastale - Scala 1:1.000

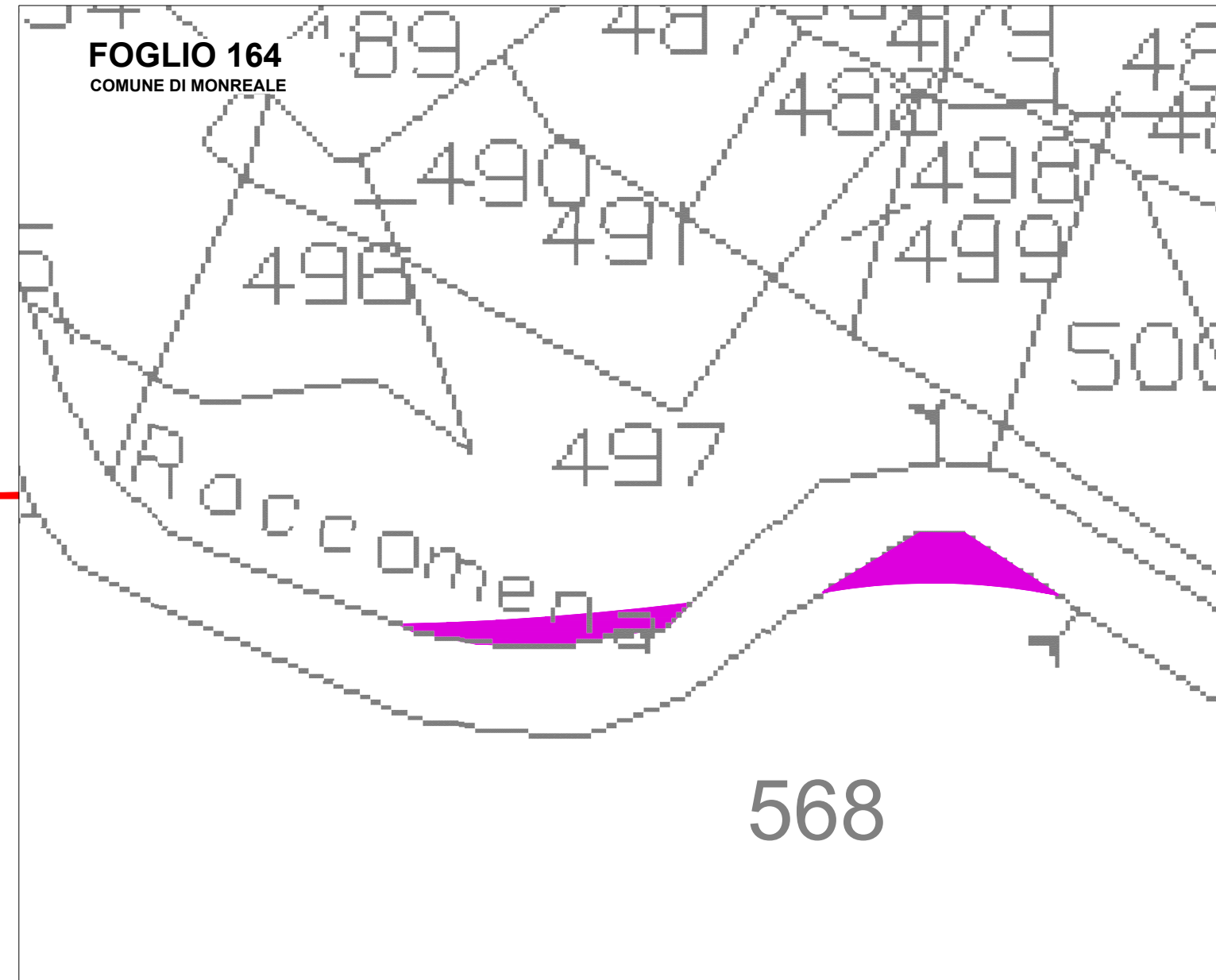



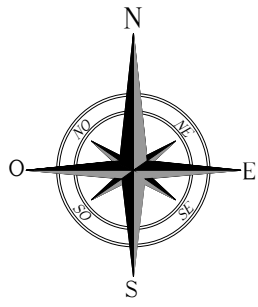

# INTERVENTI DI ADEGAMENTO VIABILITA' ESTERNA DI ACCESSO AL PARCO SU C.T.R. / CATASTALE





INT. 17

Comune di Monreale F.M. 164 p.lla 568

STRADA PROVINCIALE n.27

lat. 37.861255°N long. 13.165546°E

**LEGENDA**

-  VIABILITA' ESISTENTE
-  AREA OCCUPAZIONE REVERSIBILE DI CANTIERE
-  AREA OCCUPAZIONE REVERSIBILE DI ESERCIZIO
-  AREA OCCUPAZIONE IRREVERSIBILE
-  CONFINE COMUNALE

Corografia – Scala 1:5.000

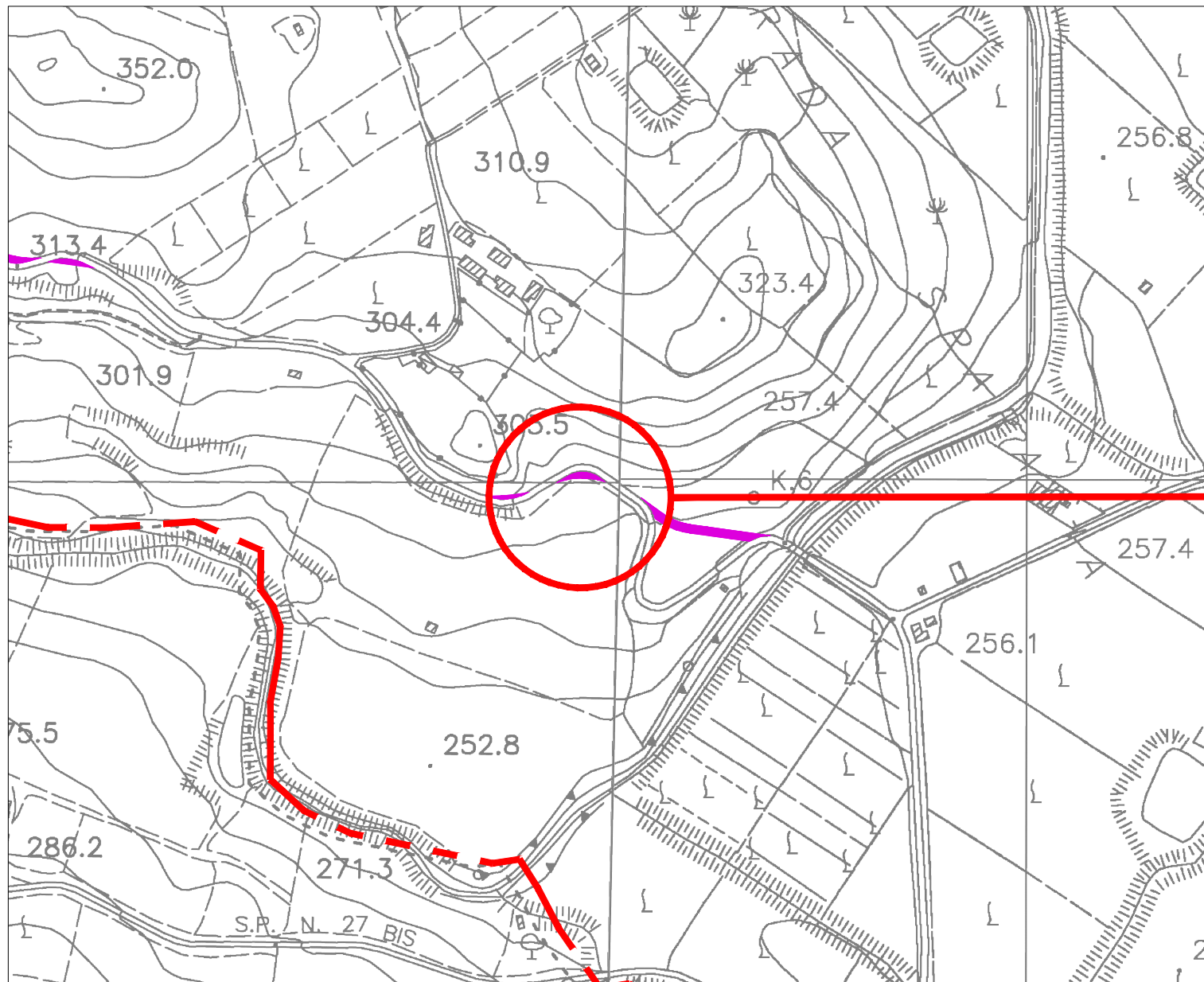

Planimetria catastale - Scala 1:1.000

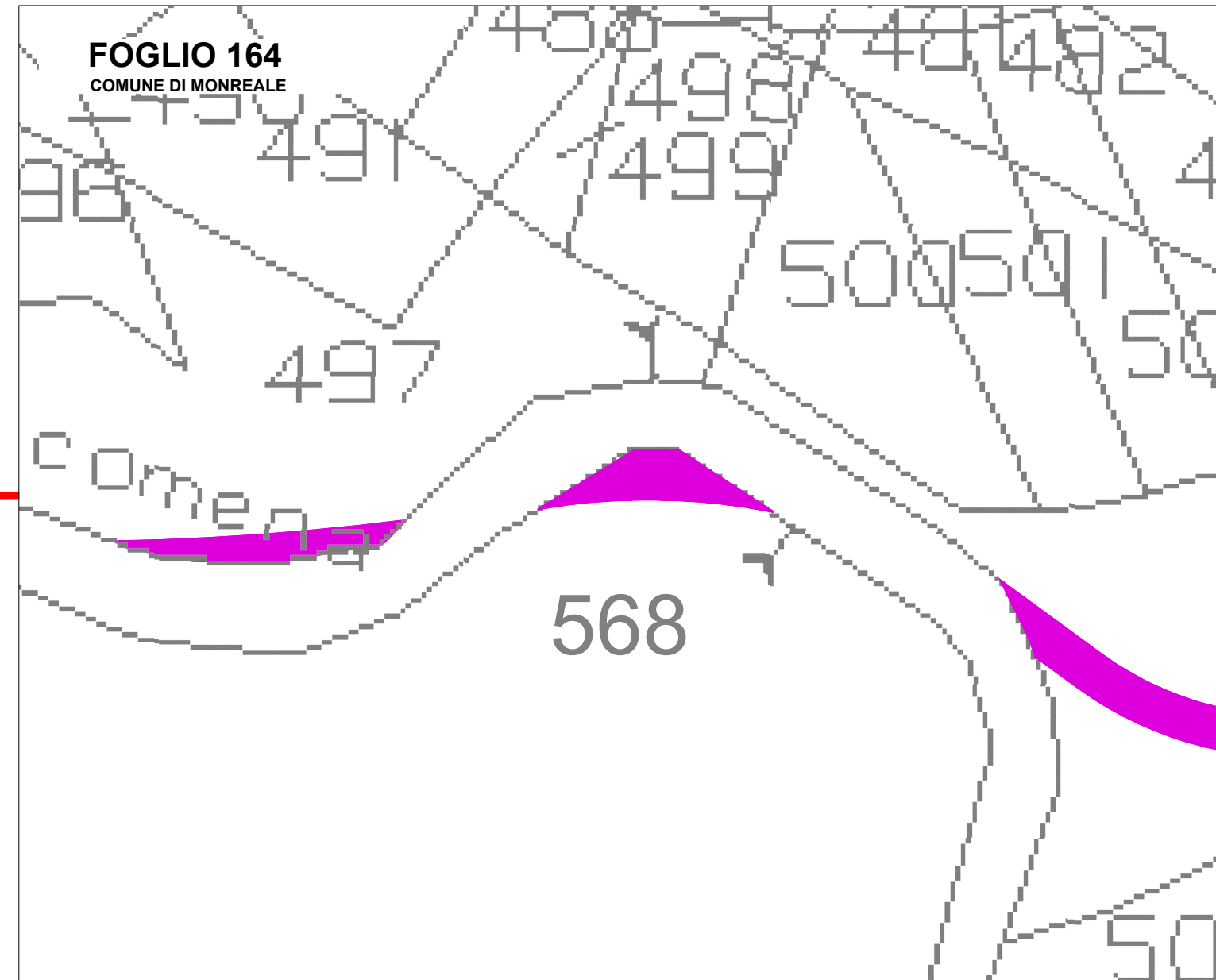

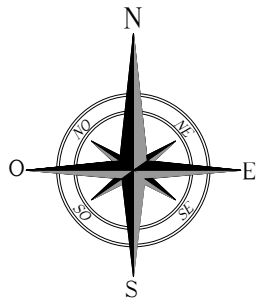

# INTERVENTI DI ADEGAMENTO VIABILITA' ESTERNA DI ACCESSO AL PARCO SU C.T.R. / CATASTALE





INT. 18

Comune di Monreale F.M. 164 p.lle 504, 505

STRADA PROVINCIALE n.27

lat. 37.860787°N long. 13.166706°E

**LEGENDA**

-  VIABILITA' ESISTENTE
-  AREA OCCUPAZIONE REVERSIBILE DI CANTIERE
-  AREA OCCUPAZIONE REVERSIBILE DI ESERCIZIO
-  AREA OCCUPAZIONE IRREVERSIBILE
-  CONFINE COMUNALE

Corografia – Scala 1:5.000

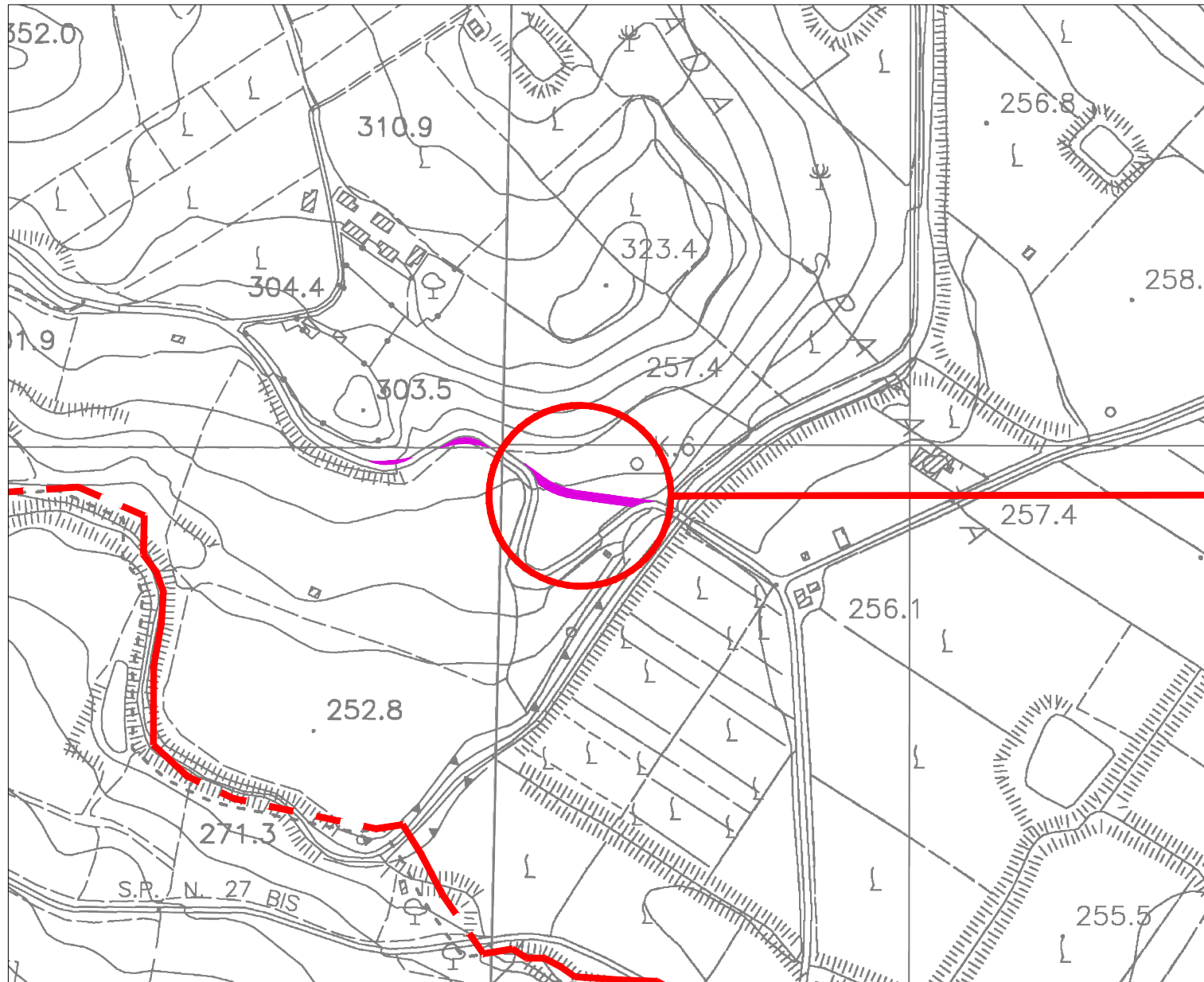

Planimetria catastale - Scala 1:1.000

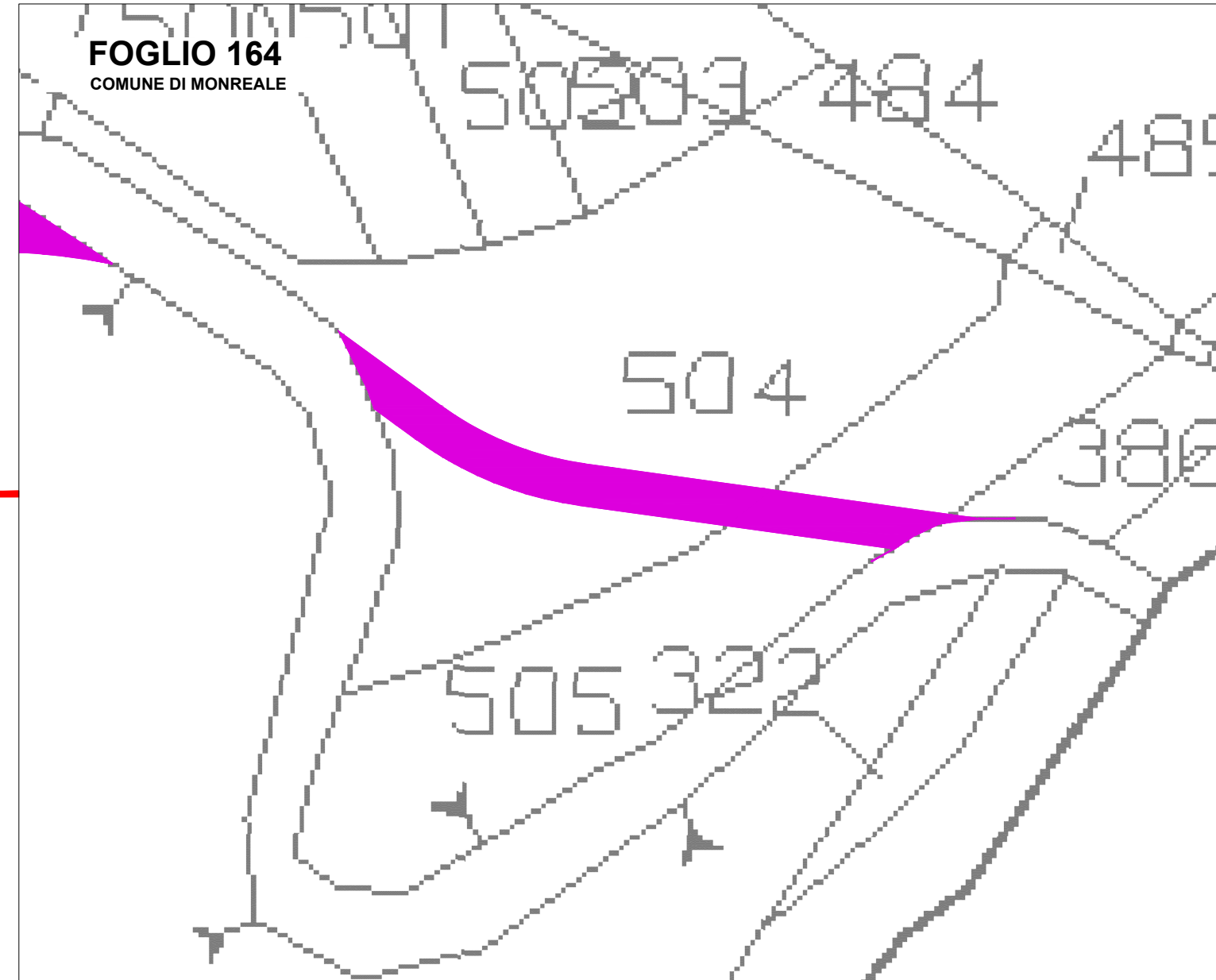

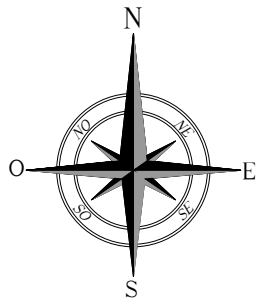

# INTERVENTI DI ADEGAMENTO VIABILITA' ESTERNA DI ACCESSO AL PARCO SU C.T.R. / CATASTALE





INT. 19

Comune di Roccamena F.M. 1 p.IIa 2

STRADA PROVINCIALE n.27

lat. 37.851055°N long. 13.175929°E

**LEGENDA**

-  VIABILITA' ESISTENTE
-  AREA OCCUPAZIONE REVERSIBILE DI CANTIERE
-  AREA OCCUPAZIONE REVERSIBILE DI ESERCIZIO
-  AREA OCCUPAZIONE IRREVERSIBILE
-  CONFINE COMUNALE

Corografia – Scala 1:5.000

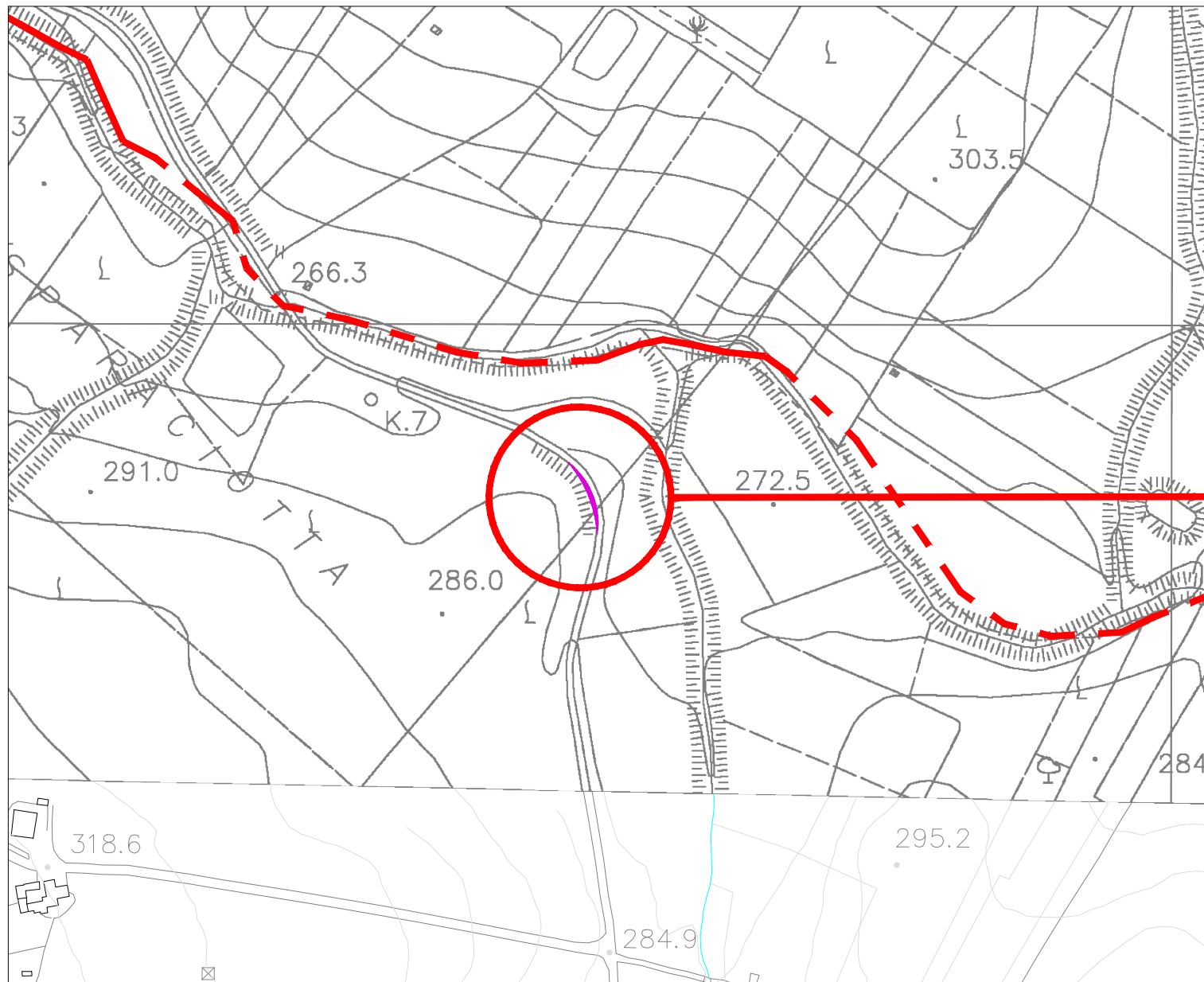

Planimetria catastale - Scala 1:1.000

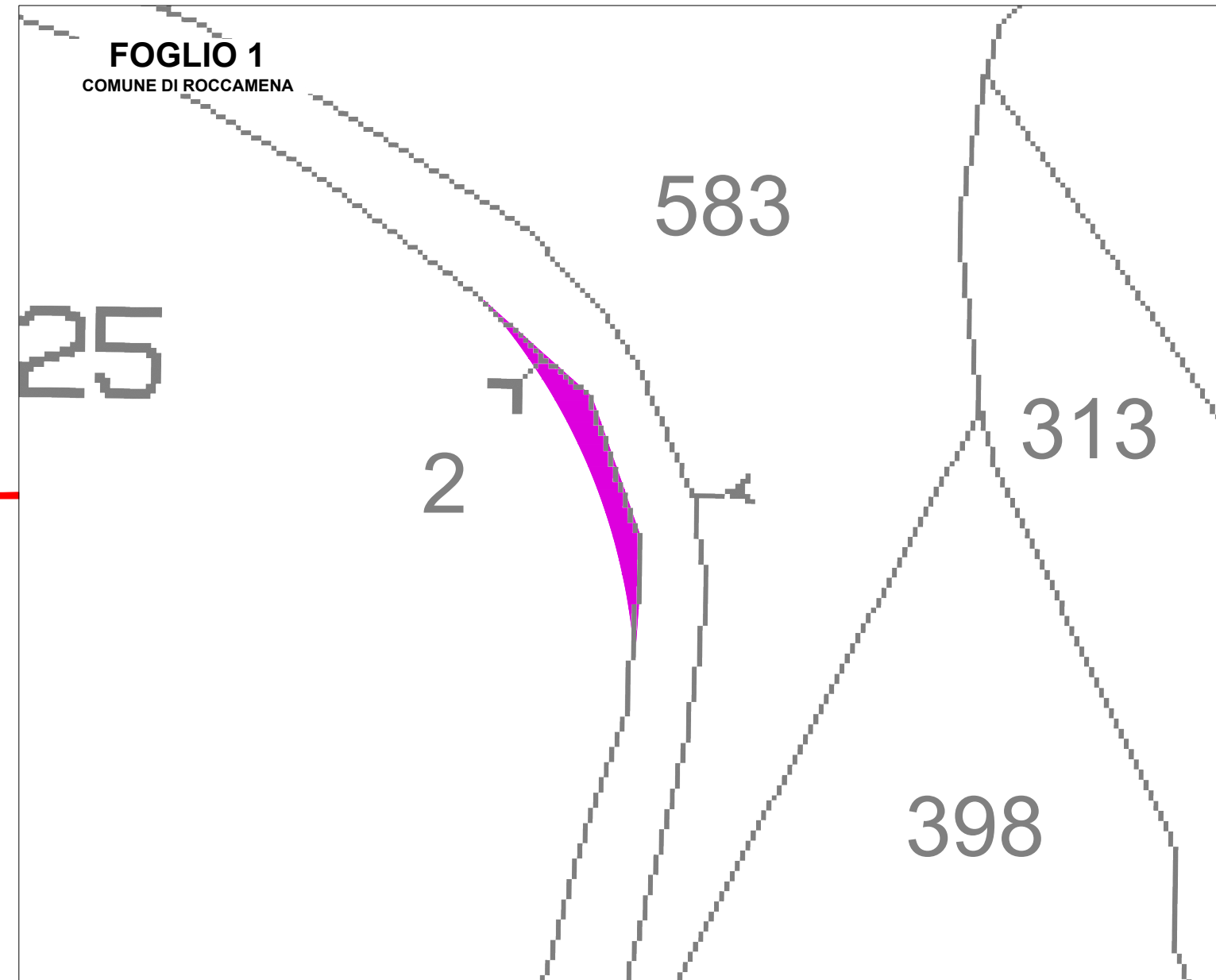

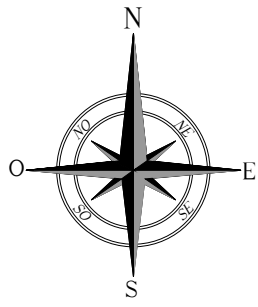

# INTERVENTI DI ADEGAMENTO VIABILITA' ESTERNA DI ACCESSO AL PARCO SU C.T.R. / CATASTALE





INT. 20

Comune di Roccamena F.M. 1 p.Ila 399

STRADA PROVINCIALE n.27

lat. 37.845483°N long. 13.177051°E

**LEGENDA**

-  VIABILITA' ESISTENTE
-  AREA OCCUPAZIONE REVERSIBILE DI CANTIERE
-  AREA OCCUPAZIONE REVERSIBILE DI ESERCIZIO
-  AREA OCCUPAZIONE IRREVERSIBILE
-  CONFINE COMUNALE

Corografia – Scala 1:5.000

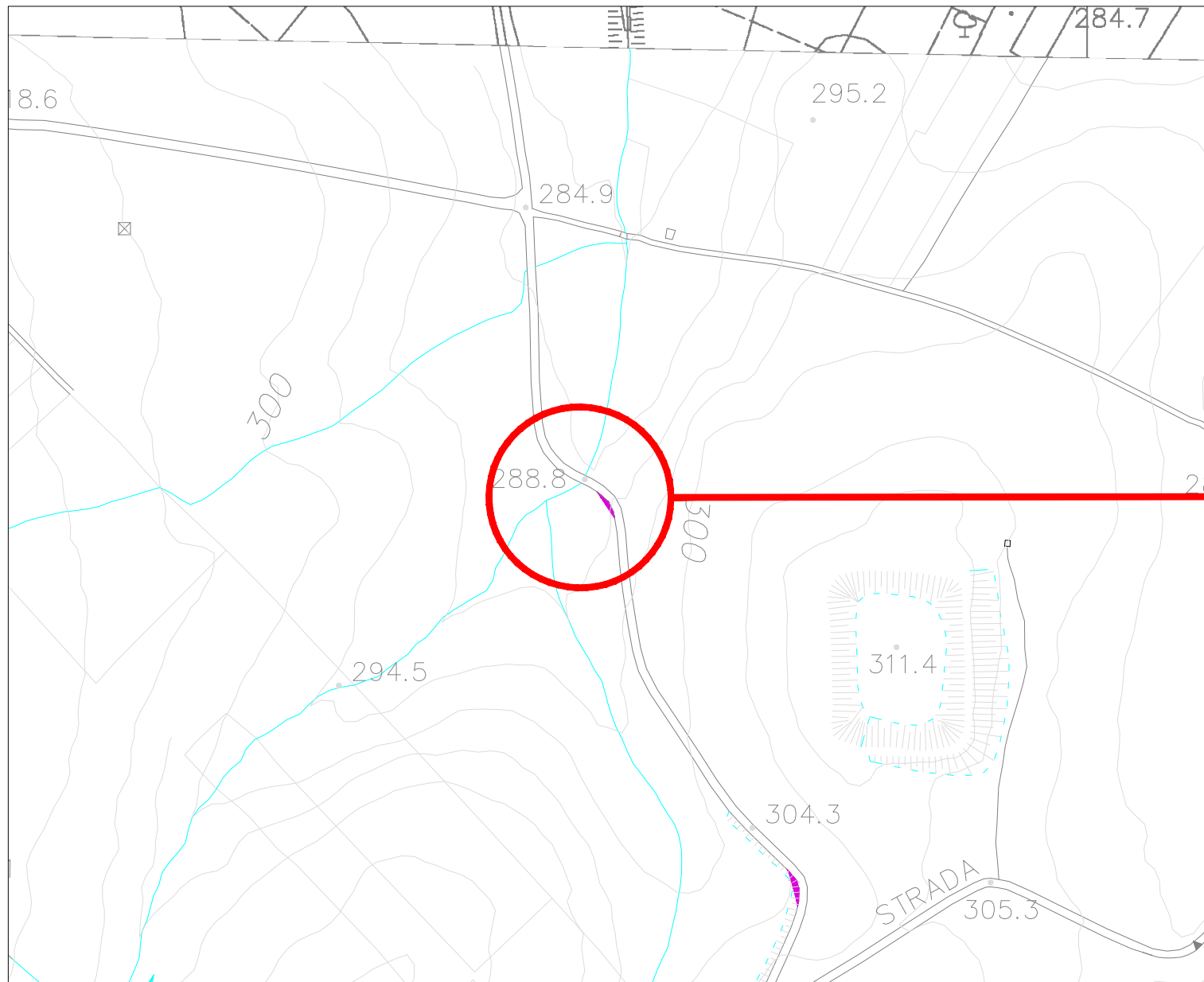

Planimetria catastale - Scala 1:1.000

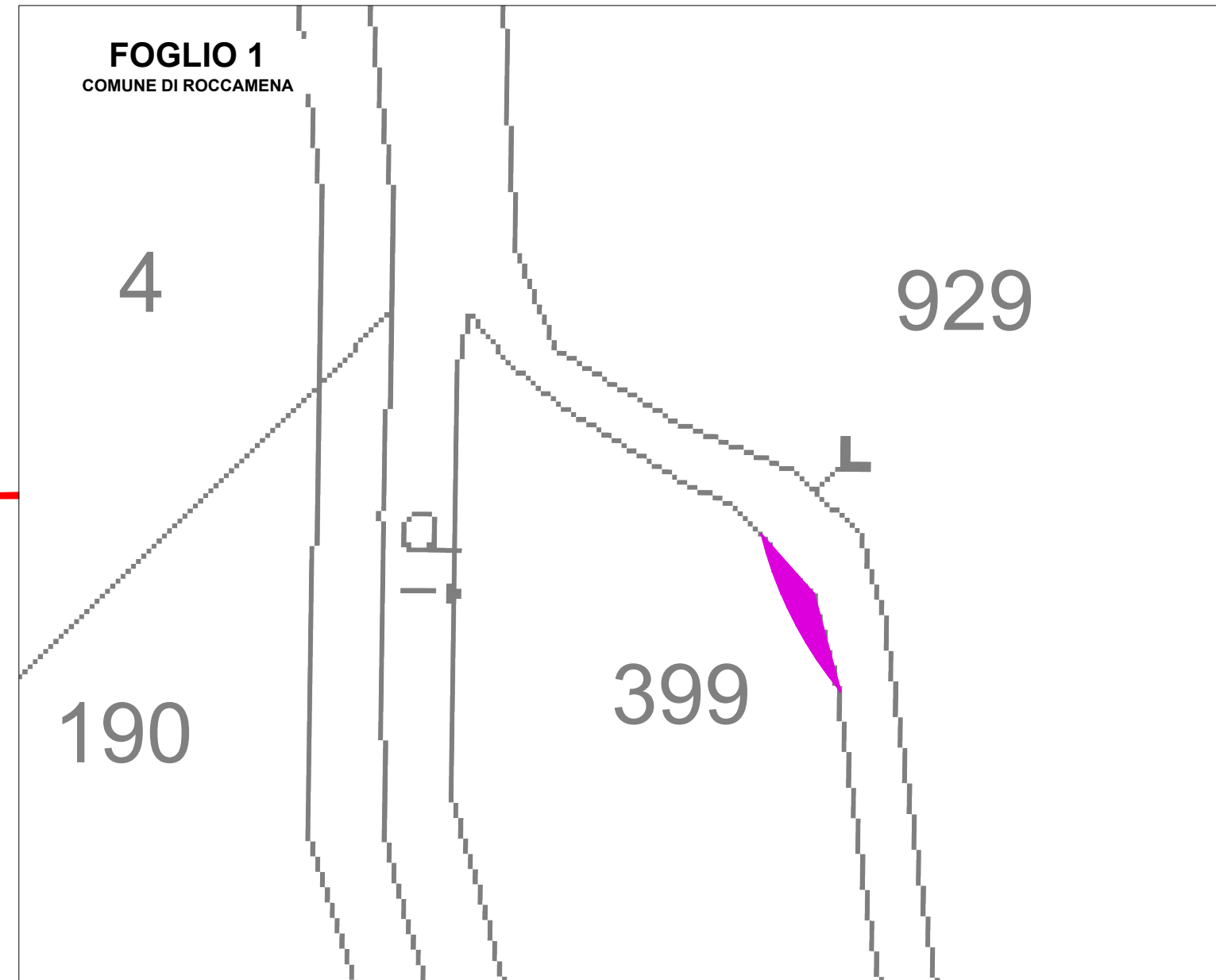

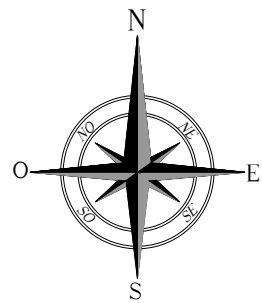

# INTERVENTI DI ADEGAMENTO VIABILITA' ESTERNA DI ACCESSO AL PARCO SU C.T.R. / CATASTALE





INT. 21

Comune di Roccamena F.M. 1 p.Ila 399

STRADA PROVINCIALE n.27

lat. 37.842573°N long. 13.178862°E

## LEGENDA

-  VIABILITA' ESISTENTE
-  AREA OCCUPAZIONE REVERSIBILE DI CANTIERE
-  AREA OCCUPAZIONE REVERSIBILE DI ESERCIZIO
-  AREA OCCUPAZIONE IRREVERSIBILE
-  CONFINE COMUNALE

Corografia – Scala 1:5.000

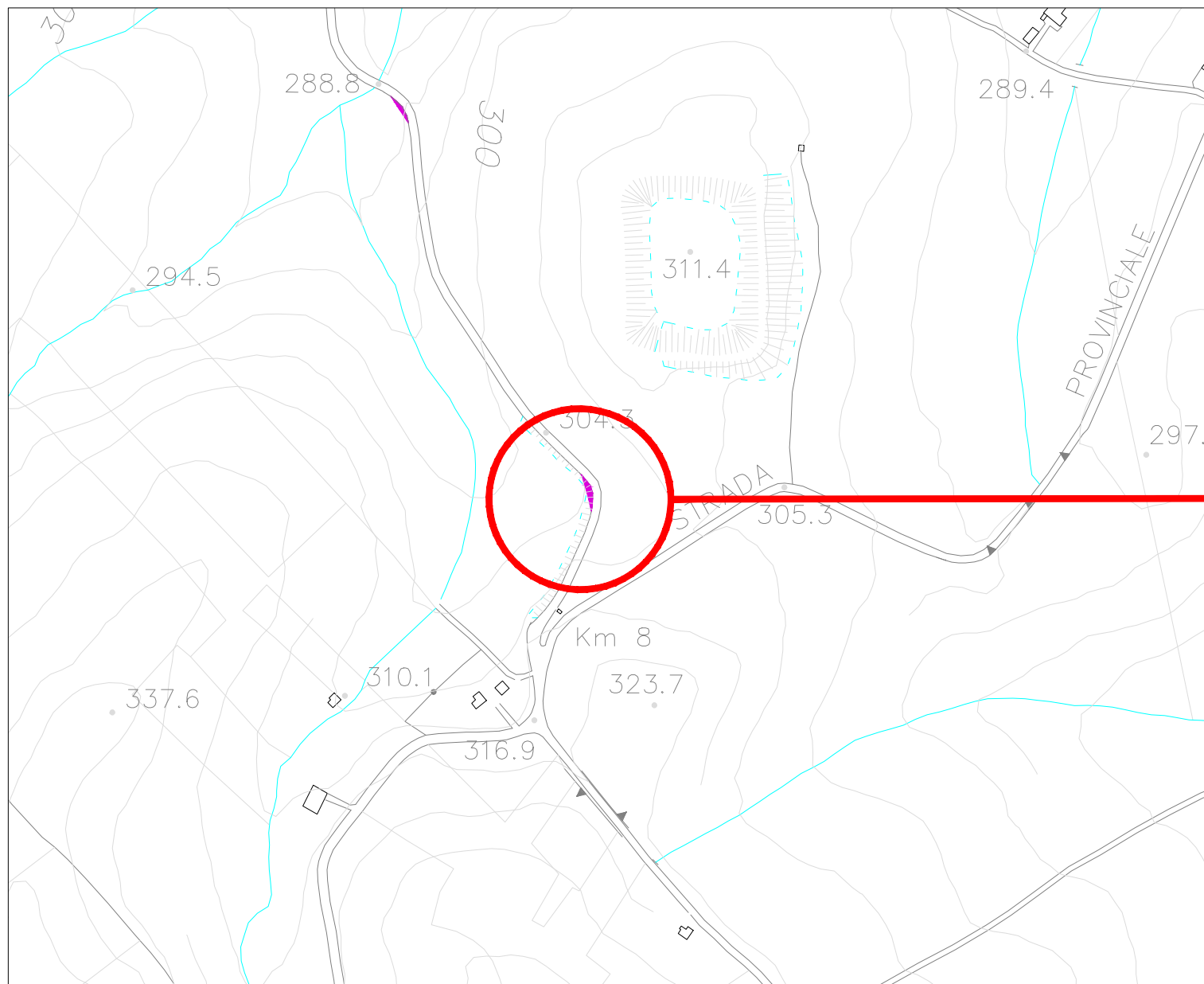

Planimetria catastale - Scala 1:1.000

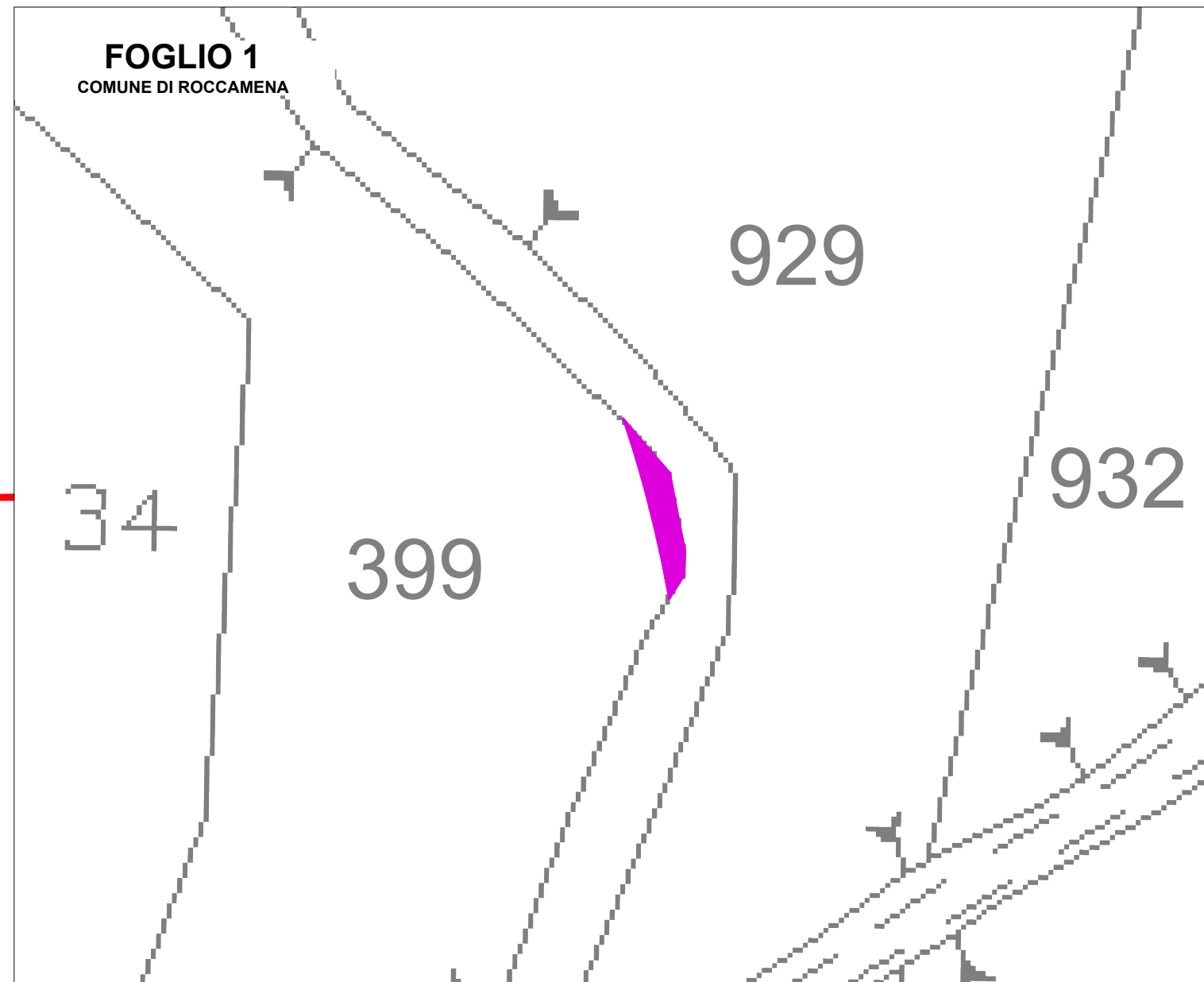

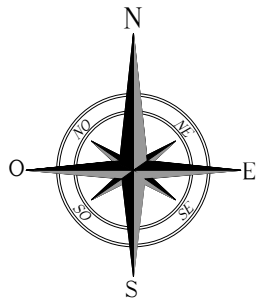

# INTERVENTI DI ADEGAMENTO VIABILITA' ESTERNA DI ACCESSO AL PARCO SU C.T.R. / CATASTALE

INT. 22

Comune di Roccamena F.M. 4 p.lla 192

REGIA TRAZZERA di Golardo - Golerdello

lat. 37.837519°N long. 13.181907°E

**LEGENDA**

- VIABILITA' ESISTENTE
- AREA OCCUPAZIONE REVERSIBILE DI CANTIERE
- AREA OCCUPAZIONE REVERSIBILE DI ESERCIZIO
- AREA OCCUPAZIONE IRREVERSIBILE
- CONFINE COMUNALE

Corografia – Scala 1:5.000

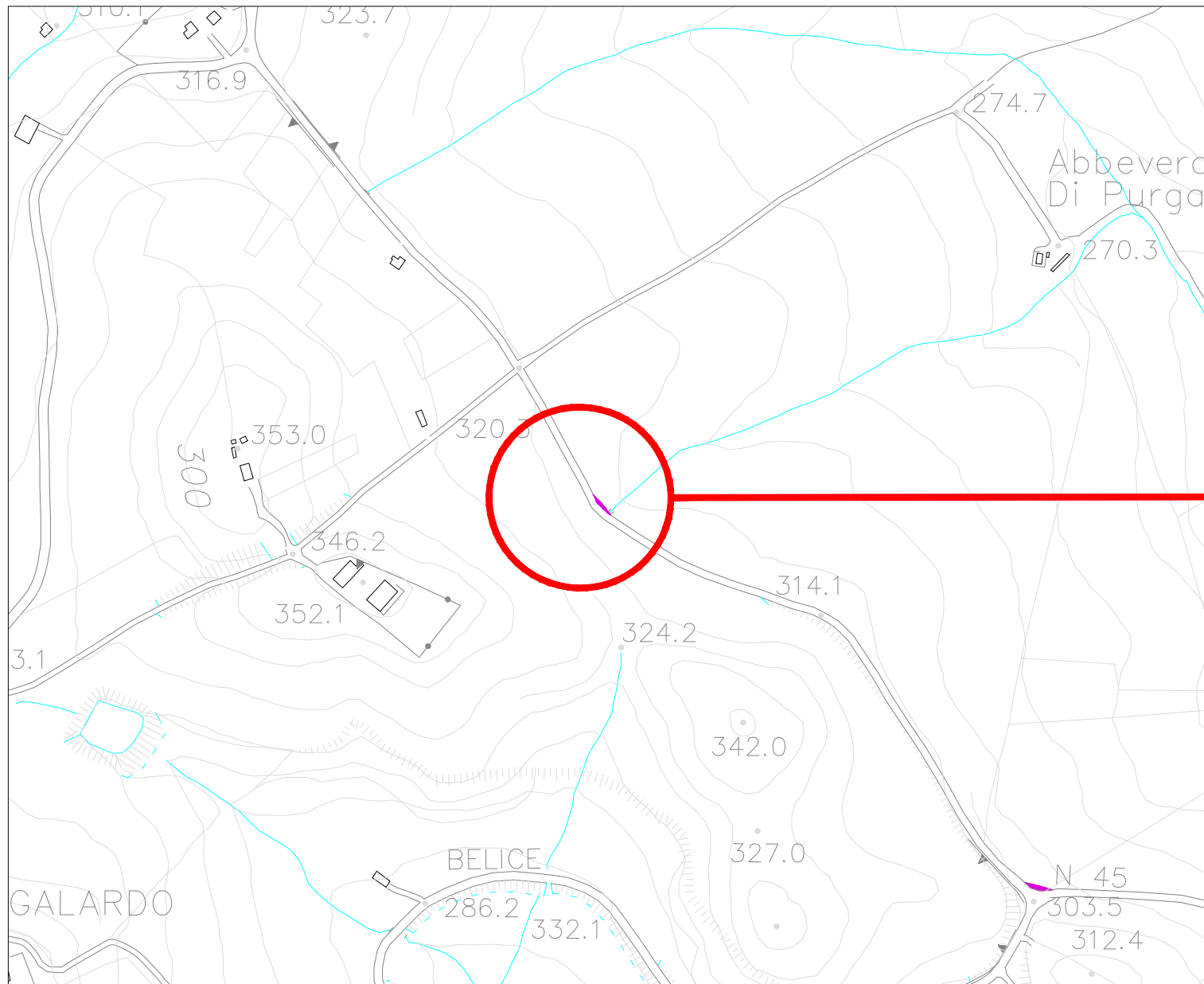

Planimetria catastale - Scala 1:1.000

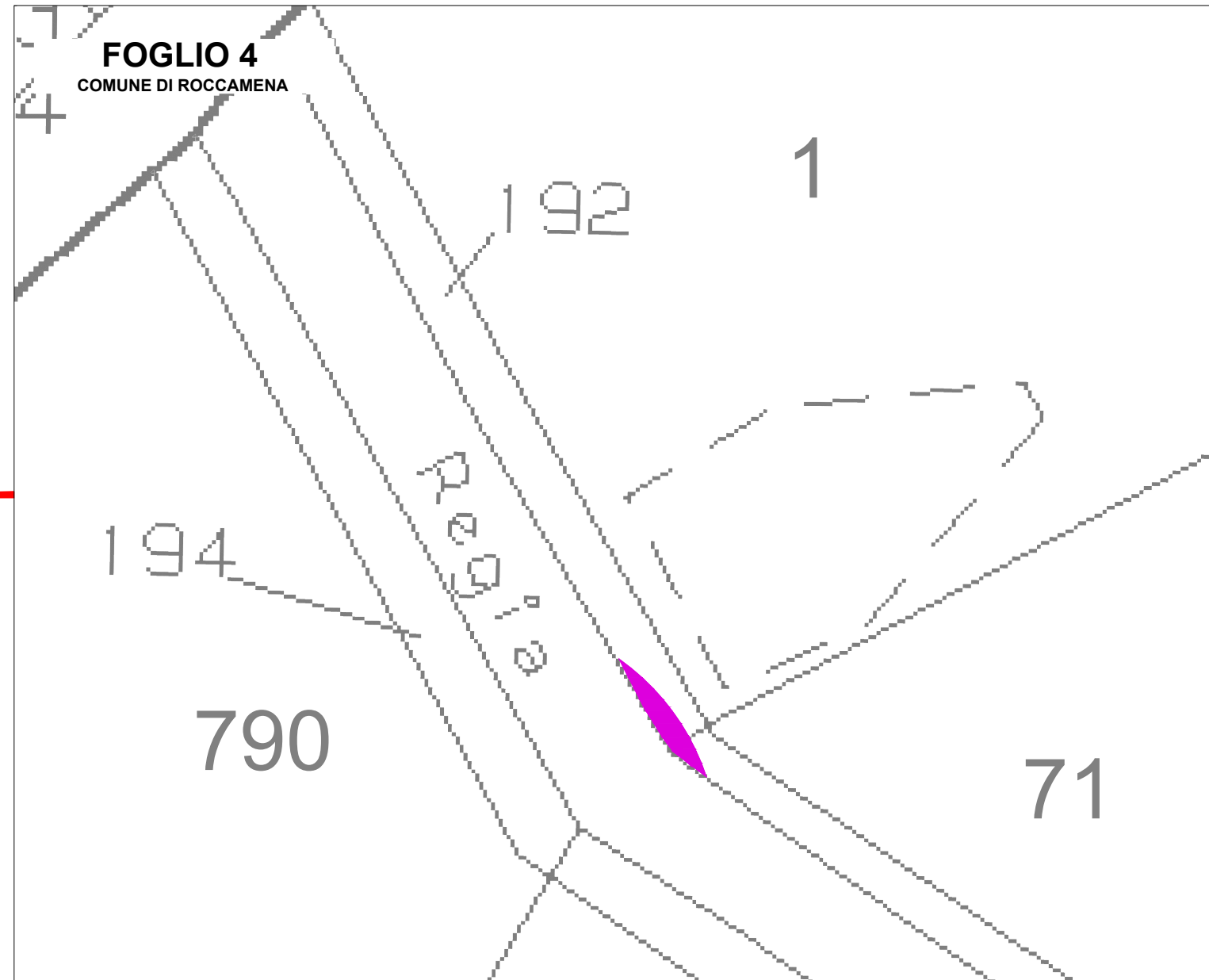

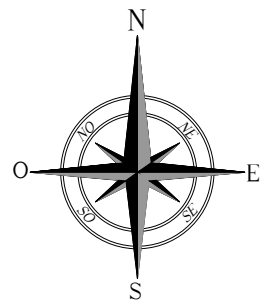

# INTERVENTI DI ADEGAMENTO VIABILITA' ESTERNA DI ACCESSO AL PARCO SU C.T.R. / CATASTALE





INT. 23

Comune di Roccamena F.M. 5 p.lla 7, 140, 184

incrocio tra REGIA TRAZZERA di Golardo - Golerdello e STRADA PROVINCIALE N.45

lat. 37.834771°N long. 13.186042°E

**LEGENDA**

-  VIABILITA' ESISTENTE
-  AREA OCCUPAZIONE REVERSIBILE DI CANTIERE
-  AREA OCCUPAZIONE REVERSIBILE DI ESERCIZIO
-  AREA OCCUPAZIONE IRREVERSIBILE
-  CONFINE COMUNALE

Corografia – Scala 1:5.000

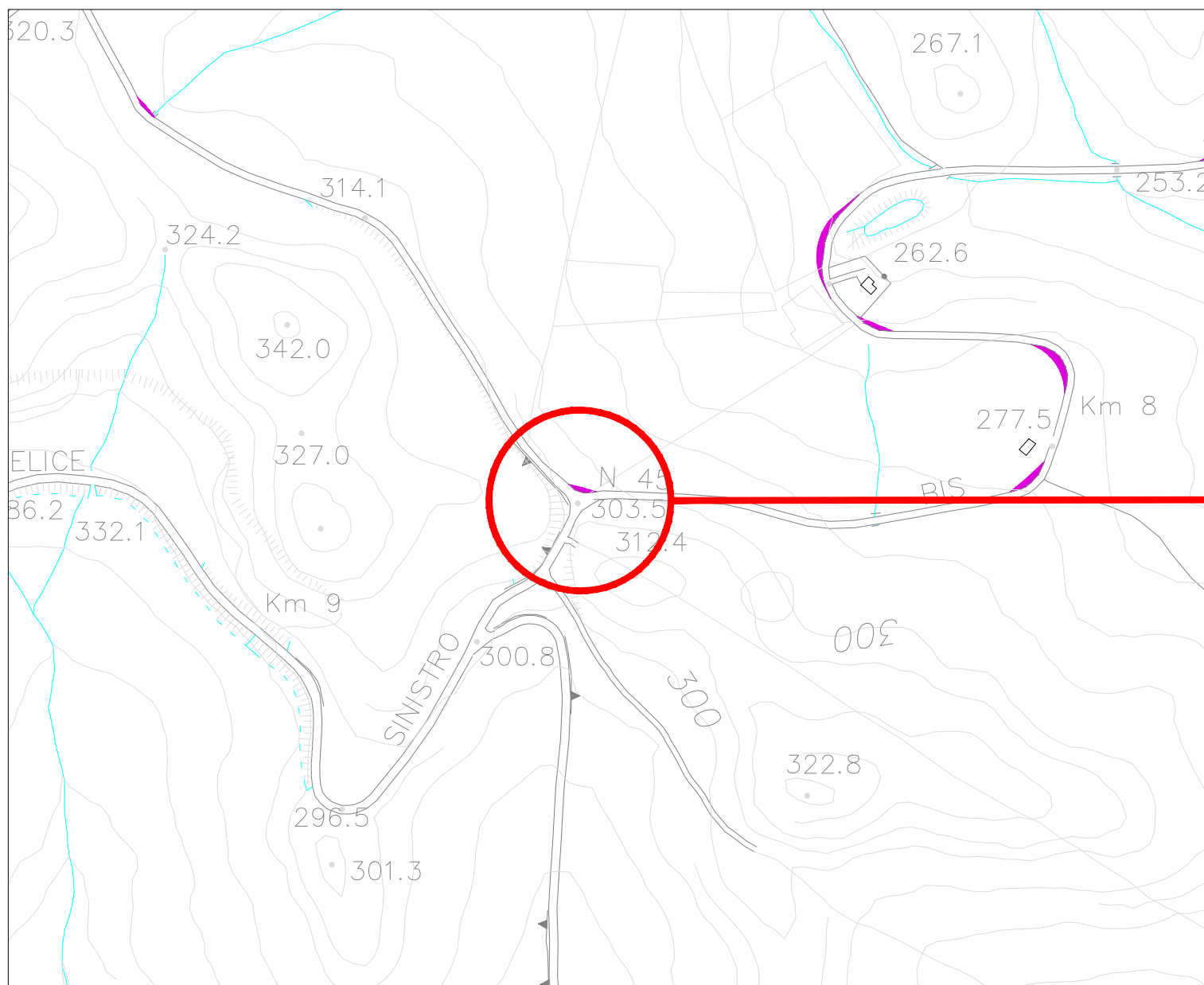

Planimetria catastale - Scala 1:1.000

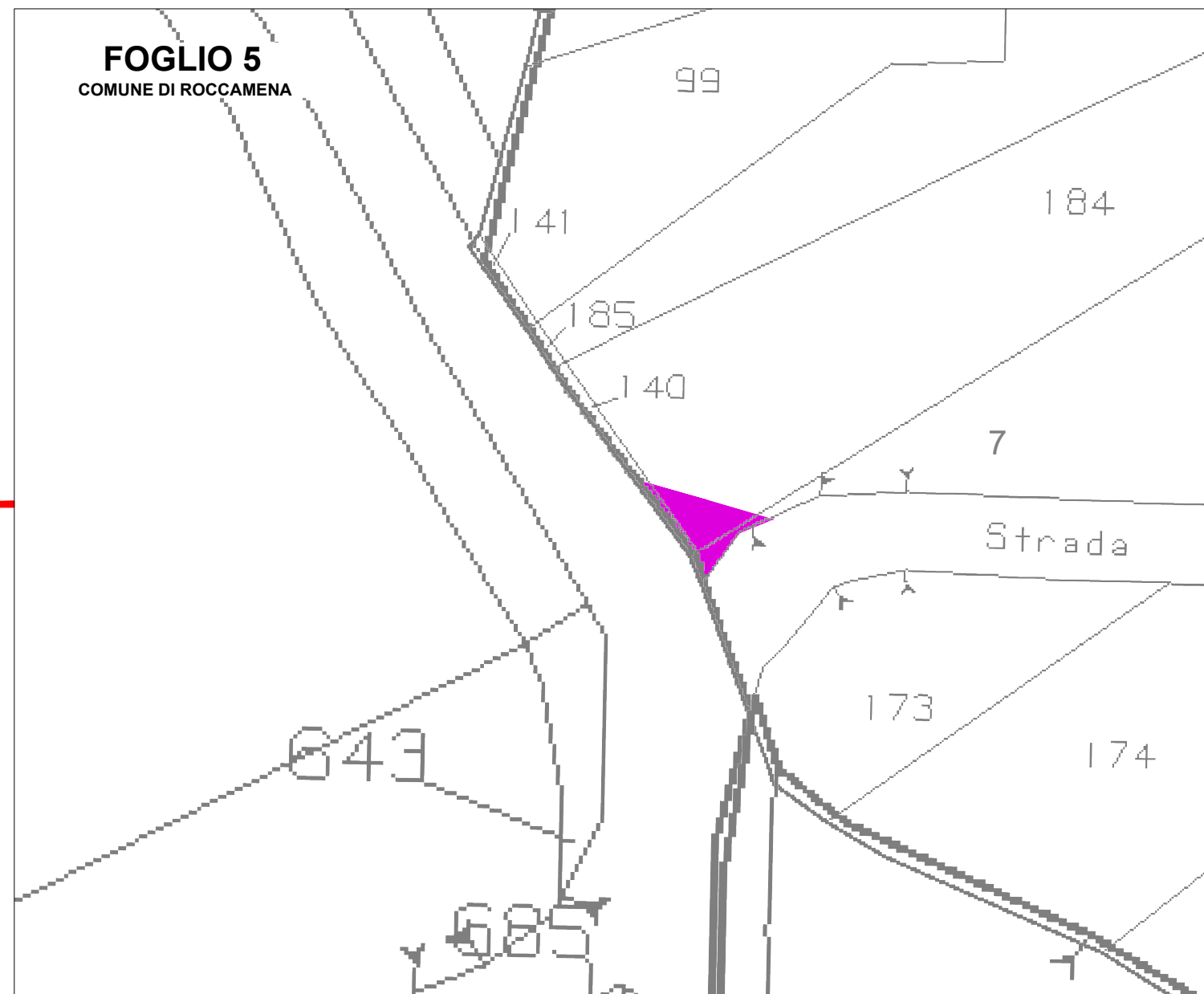

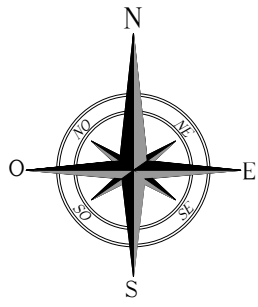

# INTERVENTI DI ADEGAMENTO VIABILITA' ESTERNA DI ACCESSO AL PARCO SU C.T.R. / CATASTALE

INT. 24

Comune di Roccamena F.M. 5 p.lla 160

STRADA PROVINCIALE N.45

lat. 37.834899°N long. 13.190255°E

**LEGENDA**

- VIABILITA' ESISTENTE
- AREA OCCUPAZIONE REVERSIBILE DI CANTIERE
- AREA OCCUPAZIONE REVERSIBILE DI ESERCIZIO
- AREA OCCUPAZIONE IRREVERSIBILE
- CONFINE COMUNALE

Corografia – Scala 1:5.000

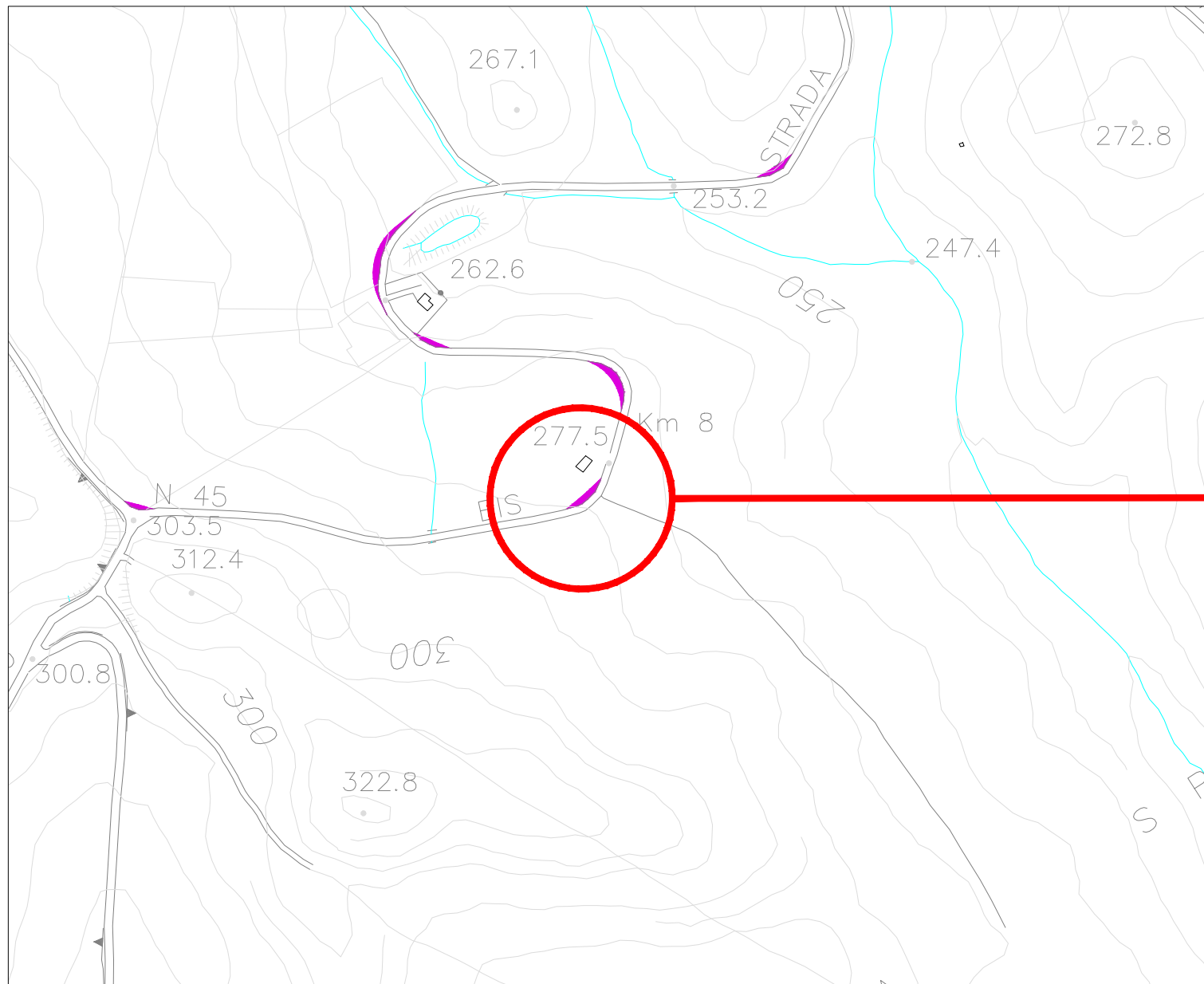

Planimetria catastale - Scala 1:1.000

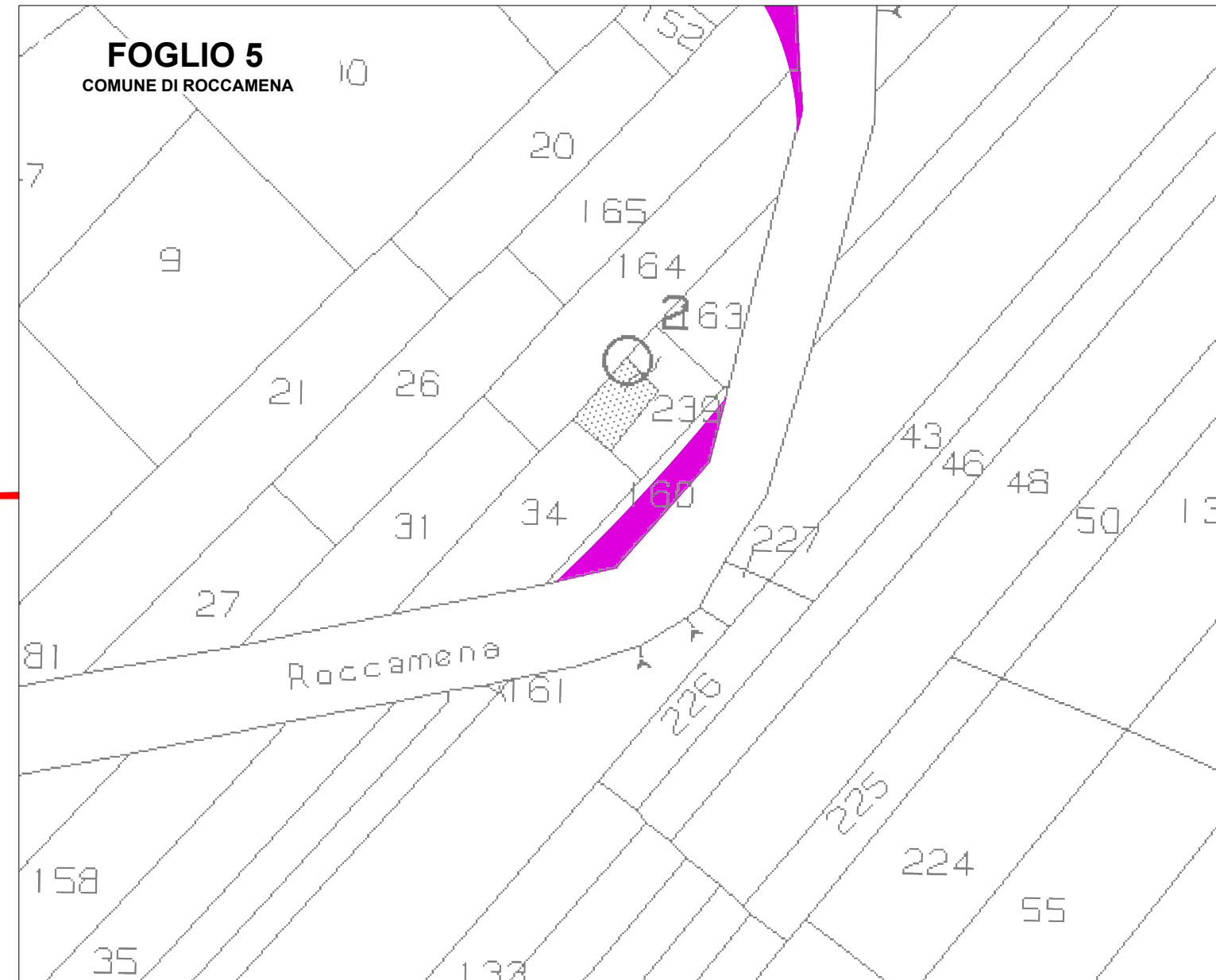



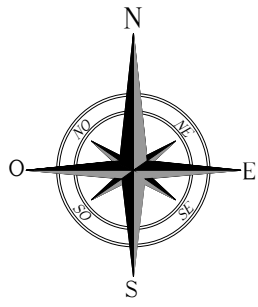

# INTERVENTI DI ADEGAMENTO VIABILITA' ESTERNA DI ACCESSO AL PARCO SU C.T.R. / CATASTALE

INT. 25

Comune di Roccamena F.M. 5 p.lle 19, 113, 164, 165

STRADA PROVINCIALE N.45

lat. 37.835858°N long. 13.190470°E

**LEGENDA**

- VIABILITA' ESISTENTE
- AREA OCCUPAZIONE REVERSIBILE DI CANTIERE
- AREA OCCUPAZIONE REVERSIBILE DI ESERCIZIO
- AREA OCCUPAZIONE IRREVERSIBILE
- CONFINE COMUNALE

Corografia – Scala 1:5.000

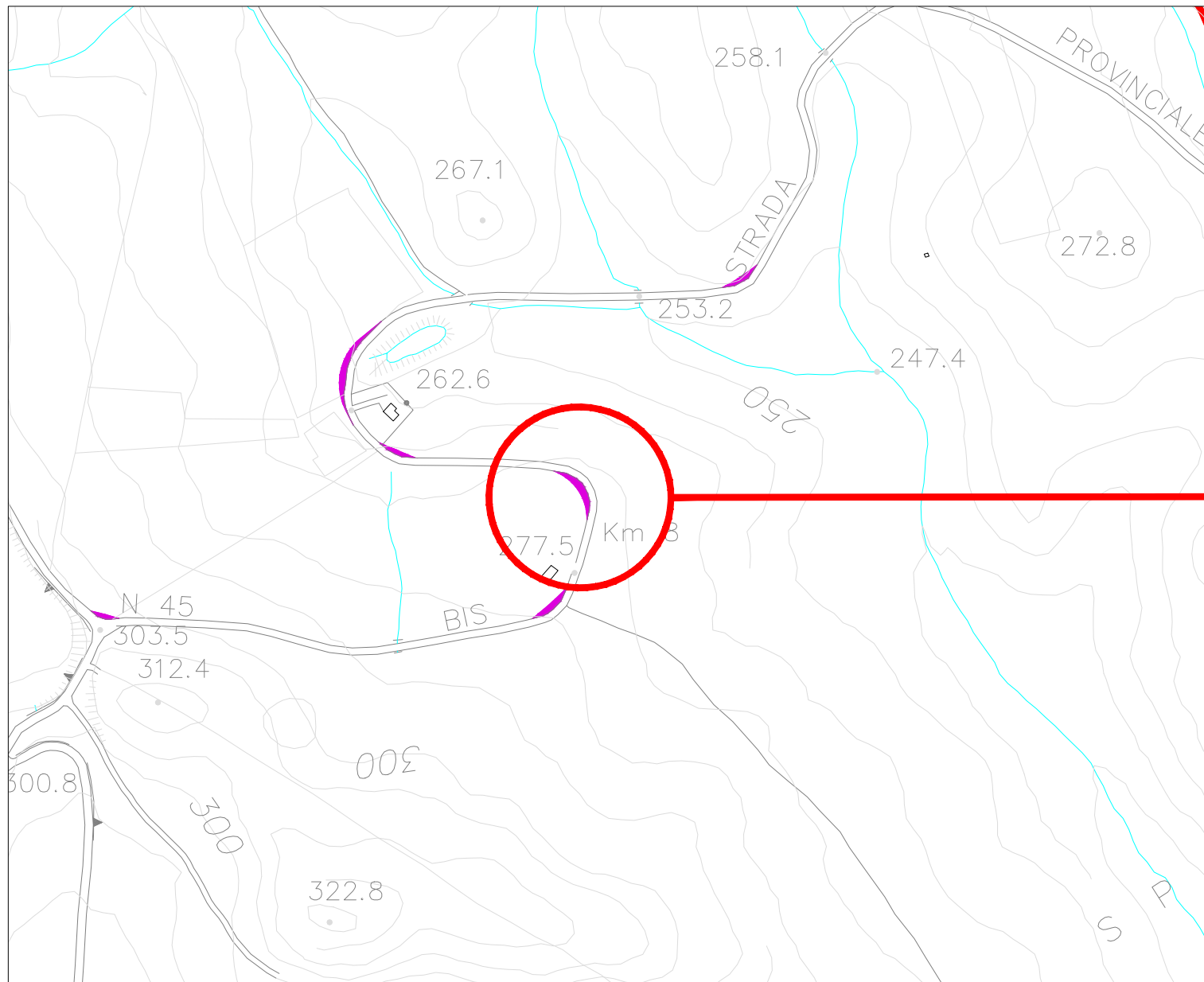

Planimetria catastale - Scala 1:1.000

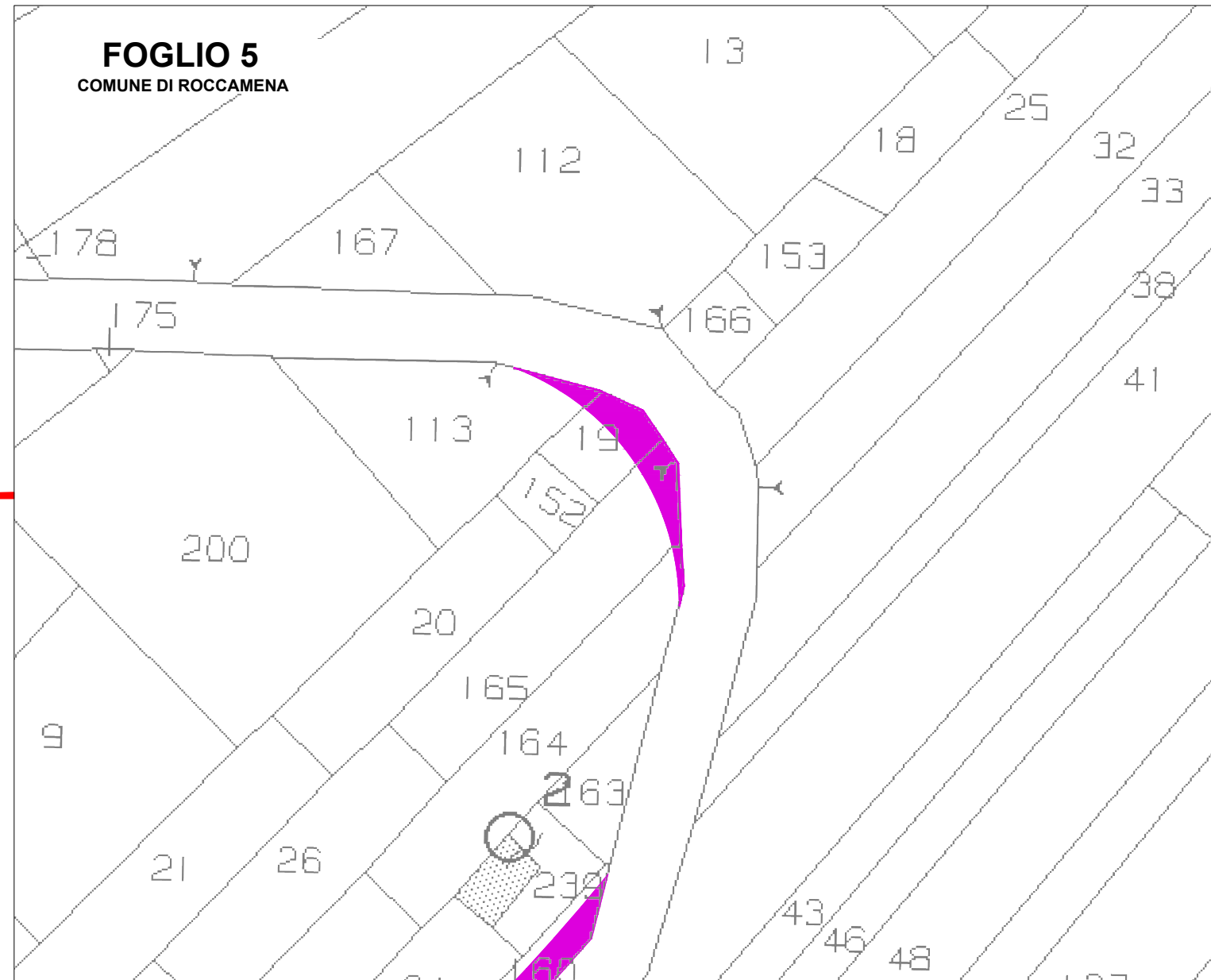

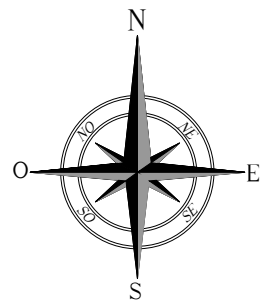

# INTERVENTI DI ADEGAMENTO VIABILITA' ESTERNA DI ACCESSO AL PARCO SU C.T.R. / CATASTALE

INT. 26





Comune di Roccamena F.M. 5 p.lle 6, 172, 238

STRADA PROVINCIALE N.45

lat. 37.836066°N

long. 13.188794°E

**LEGENDA**

-  VIABILITA' ESISTENTE
-  AREA OCCUPAZIONE REVERSIBILE DI CANTIERE
-  AREA OCCUPAZIONE REVERSIBILE DI ESERCIZIO
-  AREA OCCUPAZIONE IRREVERSIBILE
-  CONFINE COMUNALE

Corografia – Scala 1:5.000

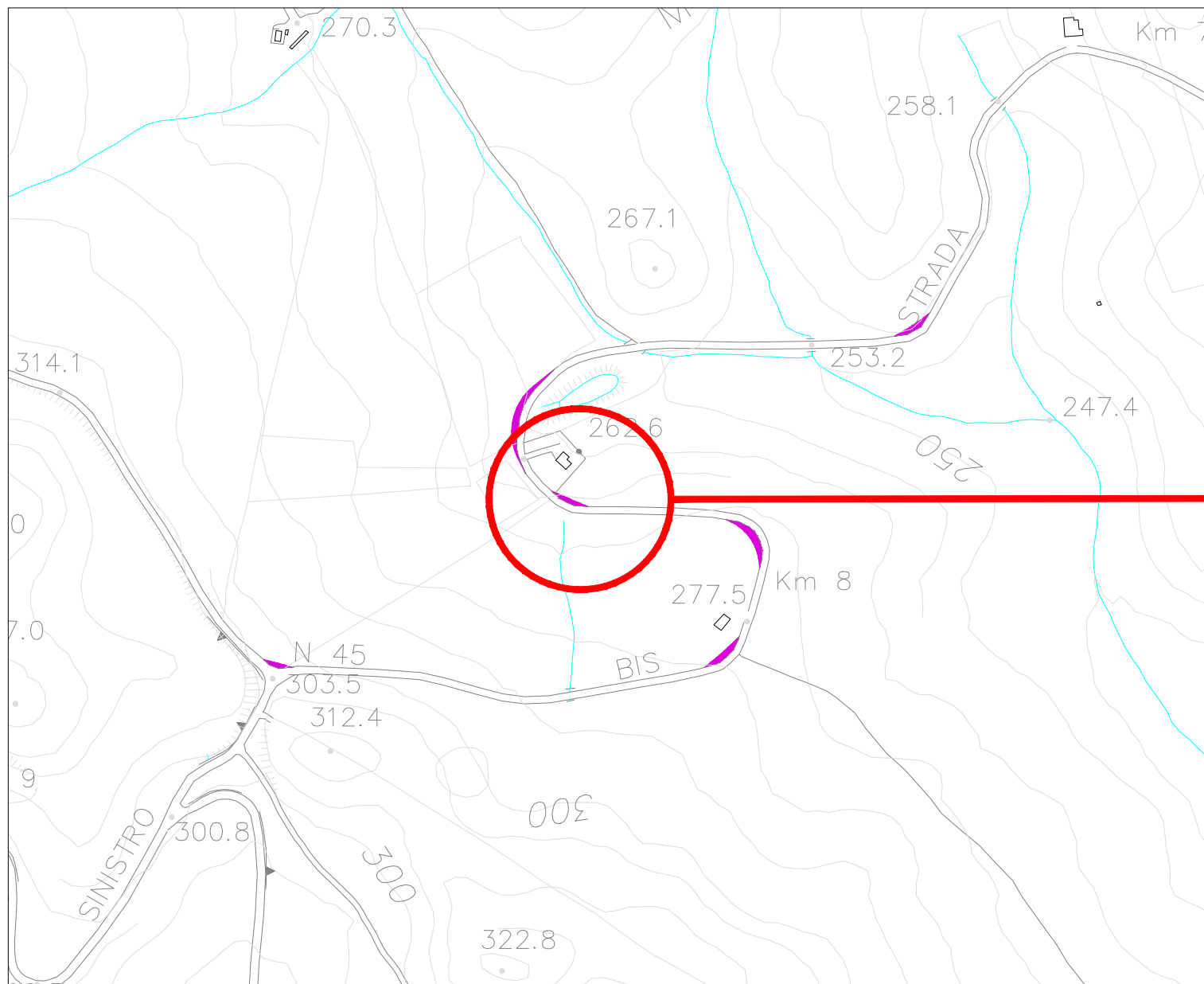

Planimetria catastale - Scala 1:1.000

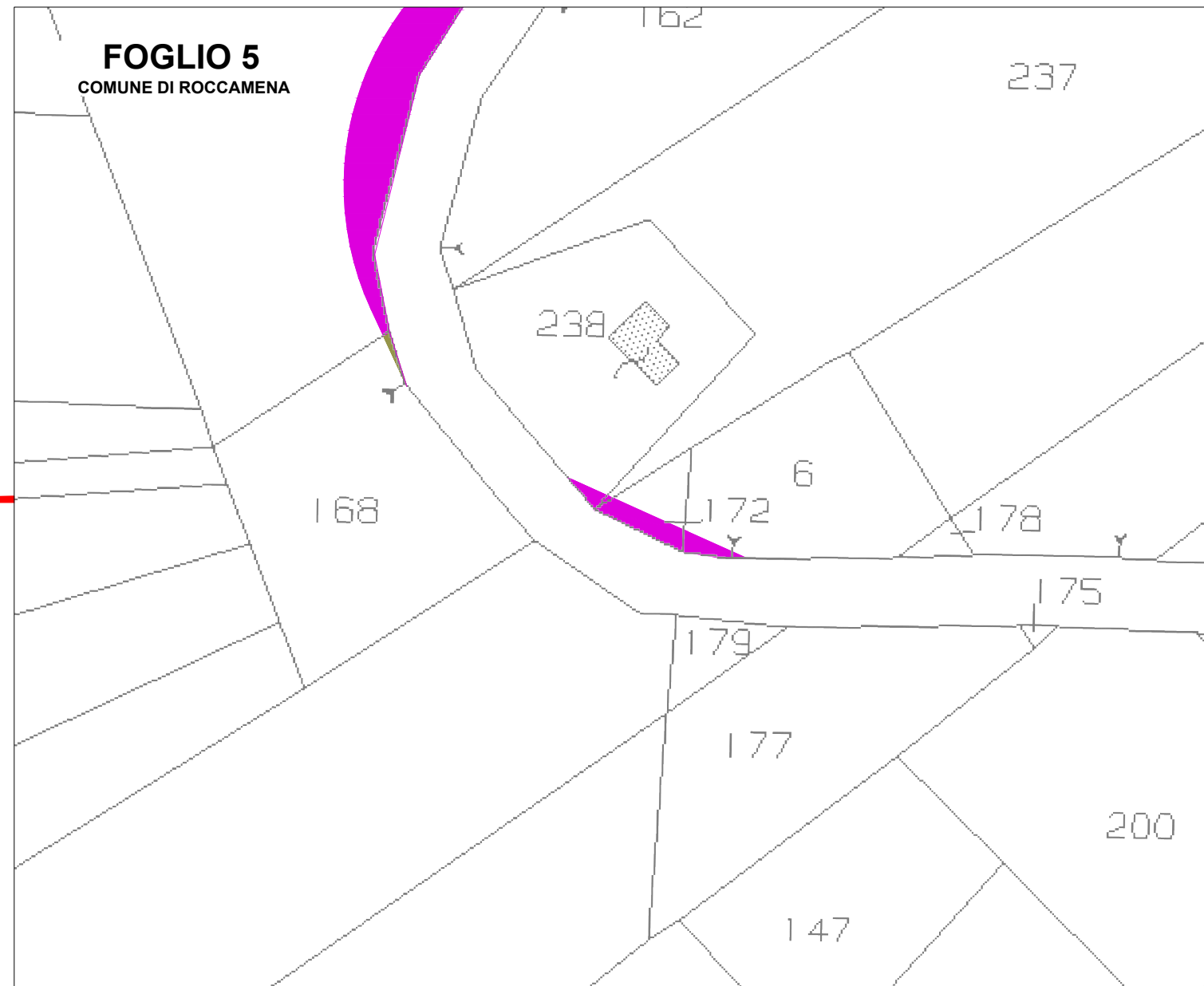

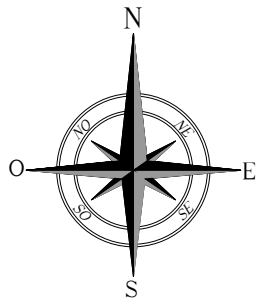

# INTERVENTI DI ADEGAMENTO VIABILITA' ESTERNA DI ACCESSO AL PARCO SU C.T.R. / CATASTALE





INT. 27

Comune di Roccamena F.M. 5 p.lle 62, 168

STRADA PROVINCIALE N.45

lat. 37.836662°N long. 13.188246°E

**LEGENDA**

-  VIABILITA' ESISTENTE
-  AREA OCCUPAZIONE REVERSIBILE DI CANTIERE
-  AREA OCCUPAZIONE REVERSIBILE DI ESERCIZIO
-  AREA OCCUPAZIONE IRREVERSIBILE
-  CONFINE COMUNALE

Corografia – Scala 1:5.000

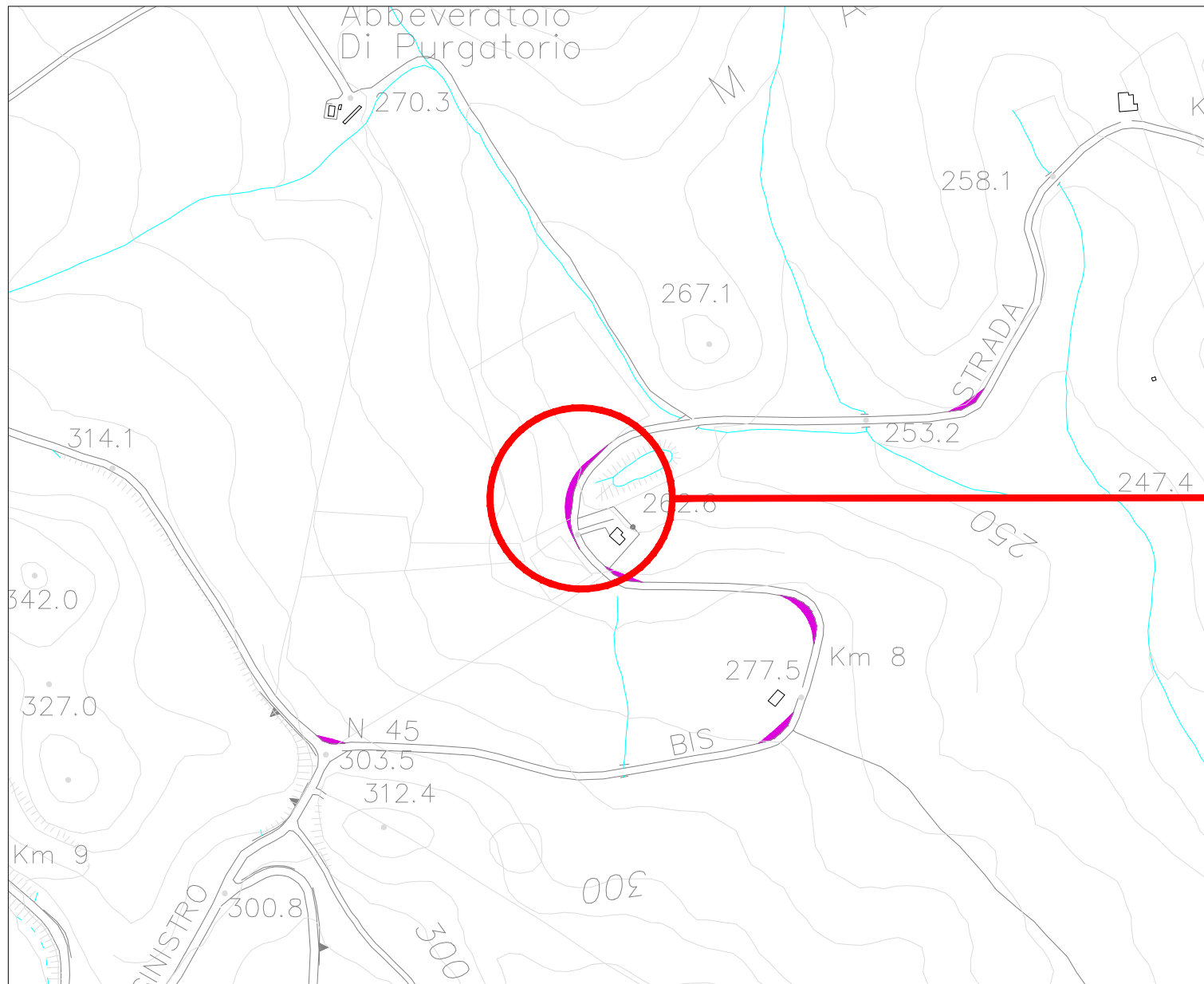

Planimetria catastale - Scala 1:1.000

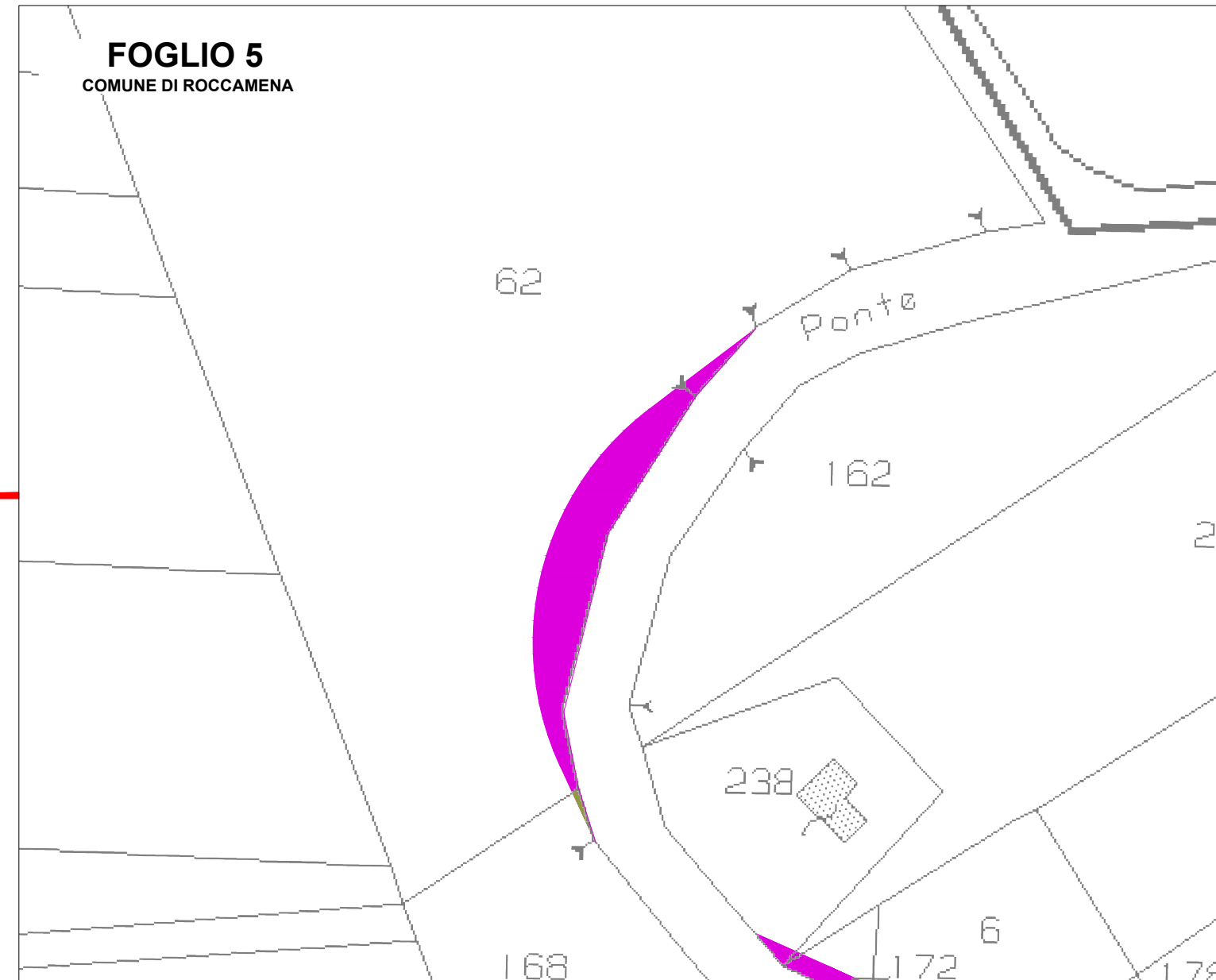

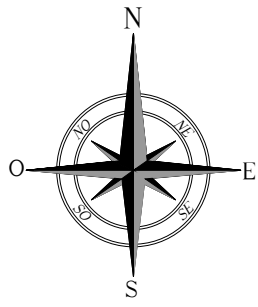

# INTERVENTI DI ADEGAMENTO VIABILITA' ESTERNA DI ACCESSO AL PARCO SU C.T.R. / CATASTALE

INT. 28





Comune di Roccamena F.M. 6 p.lle 151, 155

STRADA PROVINCIALE N.45

lat. 37.837403°N

long. 13.191955°E

**LEGENDA**

-  VIABILITA' ESISTENTE
-  AREA OCCUPAZIONE REVERSIBILE DI CANTIERE
-  AREA OCCUPAZIONE REVERSIBILE DI ESERCIZIO
-  AREA OCCUPAZIONE IRREVERSIBILE
-  CONFINE COMUNALE

Corografia – Scala 1:5.000

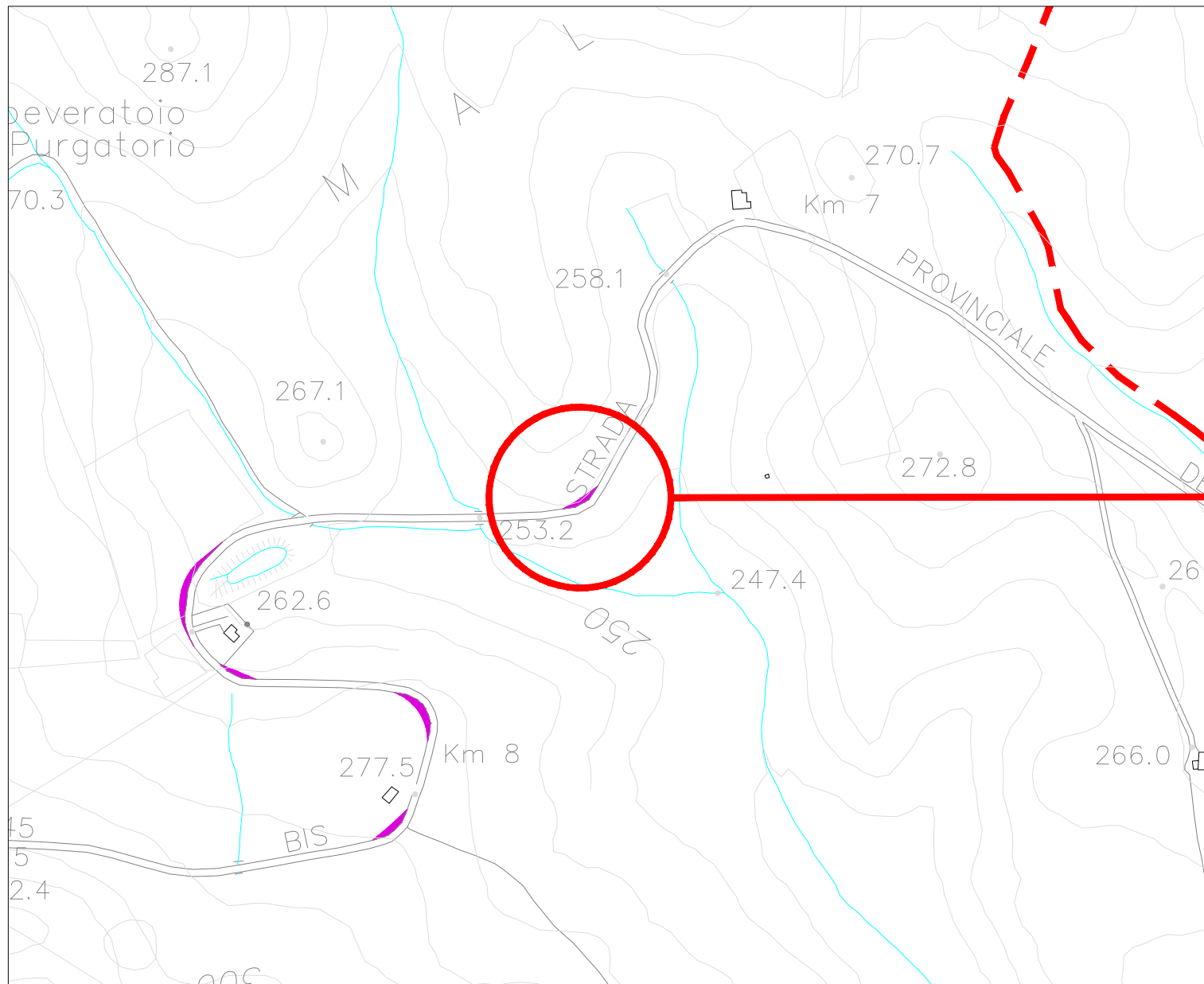

Planimetria catastale - Scala 1:1.000

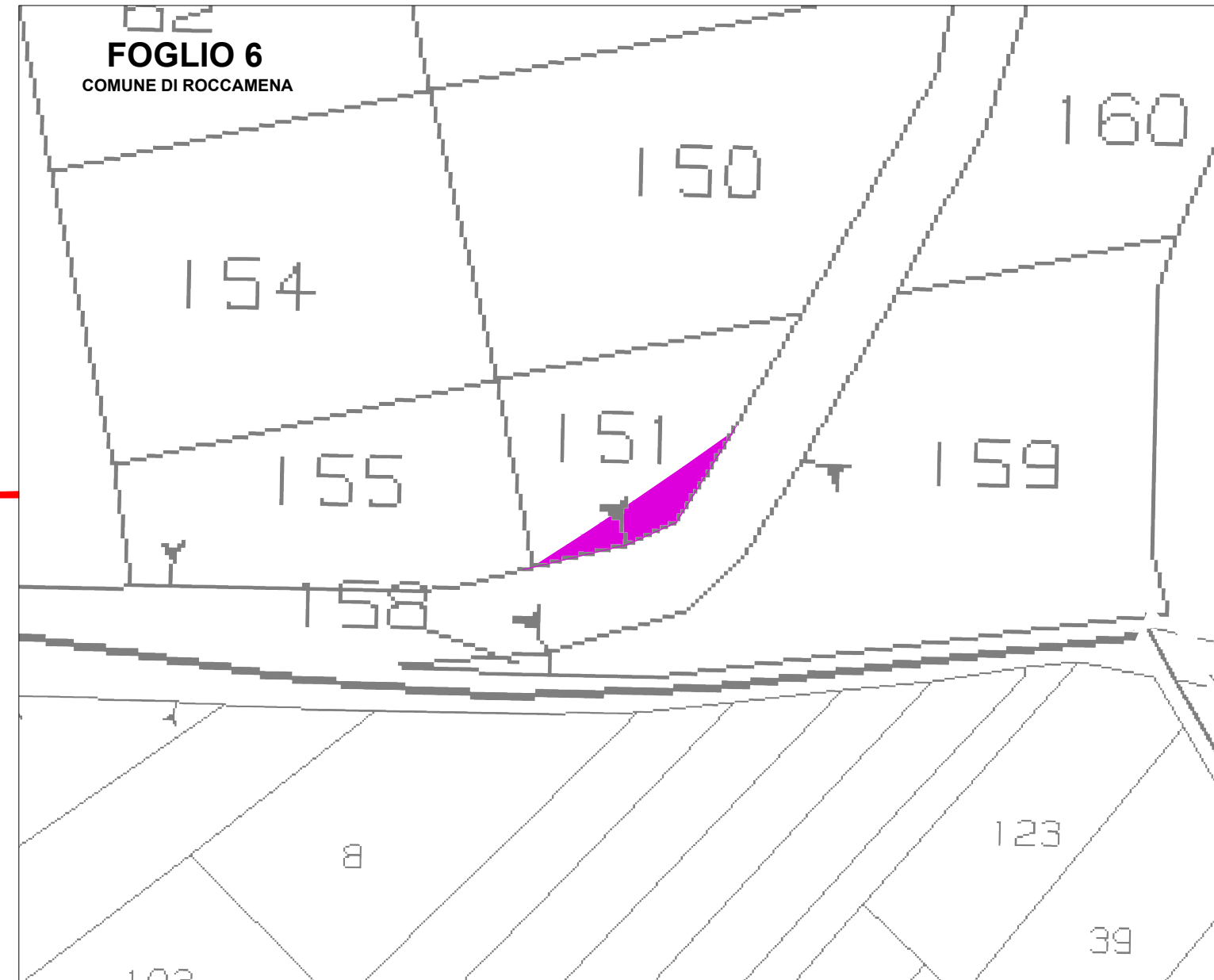

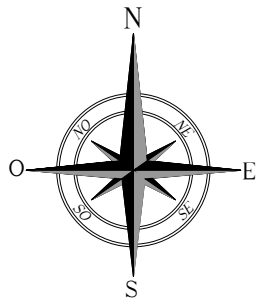

# INTERVENTI DI ADEGAMENTO VIABILITA' ESTERNA DI ACCESSO AL PARCO SU C.T.R. / CATASTALE

INT. 29





Comune di Roccamena F.M. 6 p.lle 161, 162

STRADA PROVINCIALE N.45

lat. 37.838774°N

long. 13.192558°E

## LEGENDA

-  VIABILITA' ESISTENTE
-  AREA OCCUPAZIONE REVERSIBILE DI CANTIERE
-  AREA OCCUPAZIONE REVERSIBILE DI ESERCIZIO
-  AREA OCCUPAZIONE IRREVERSIBILE
-  CONFINE COMUNALE

Corografia – Scala 1:5.000

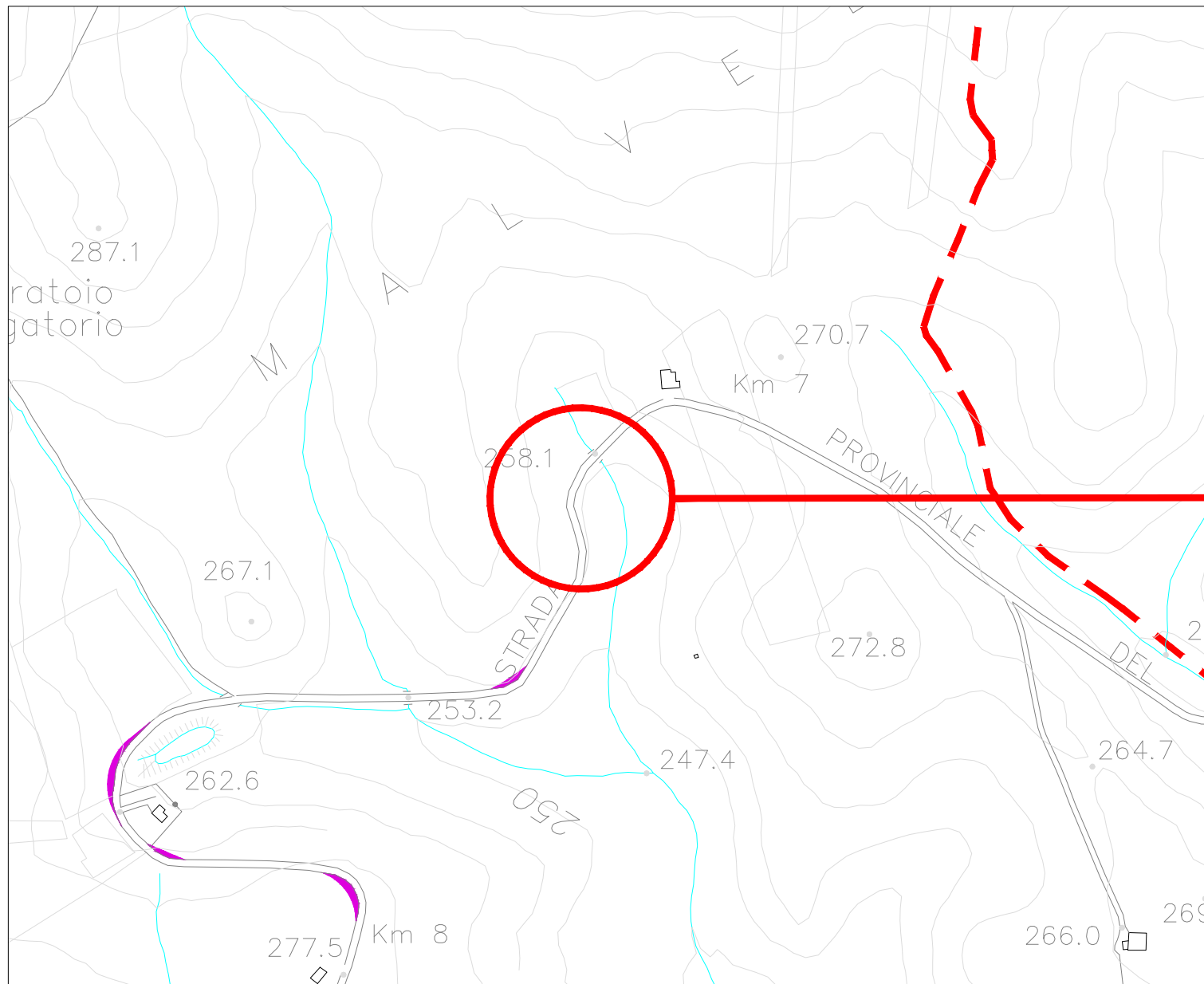

Planimetria catastale - Scala 1:1.000

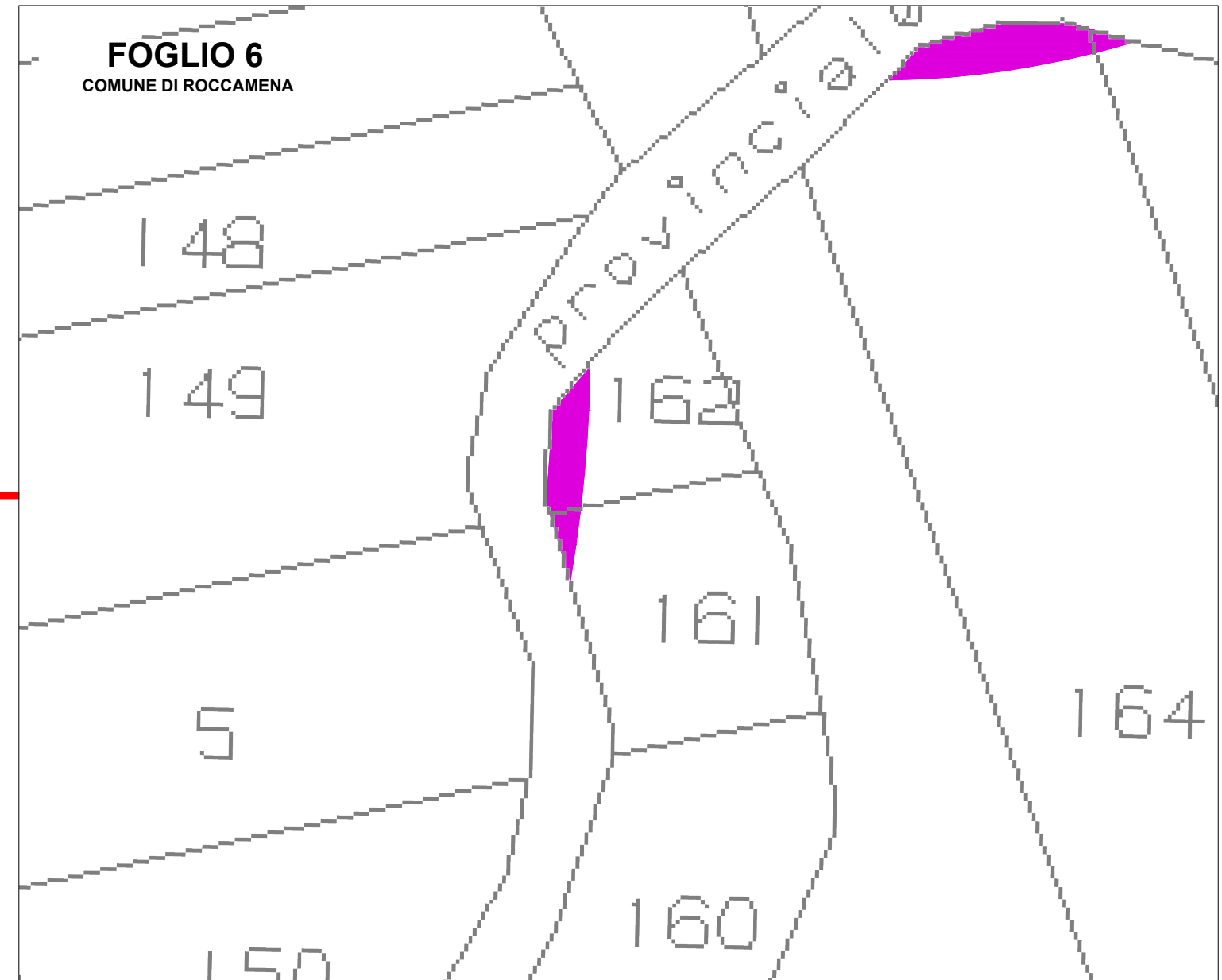

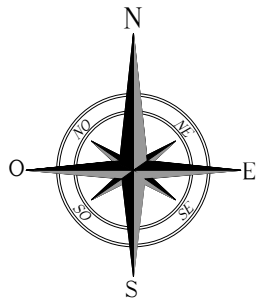

# INTERVENTI DI ADEGAMENTO VIABILITA' ESTERNA DI ACCESSO AL PARCO SU C.T.R. / CATASTALE





INT. 30

Comune di Roccamena F.M. 6 p.lle 164, 178

STRADA PROVINCIALE N.45

lat. 37.839463°N long. 13.193450°E

**LEGENDA**

-  VIABILITA' ESISTENTE
-  AREA OCCUPAZIONE REVERSIBILE DI CANTIERE
-  AREA OCCUPAZIONE REVERSIBILE DI ESERCIZIO
-  AREA OCCUPAZIONE IRREVERSIBILE
-  CONFINE COMUNALE

Corografia – Scala 1:5.000

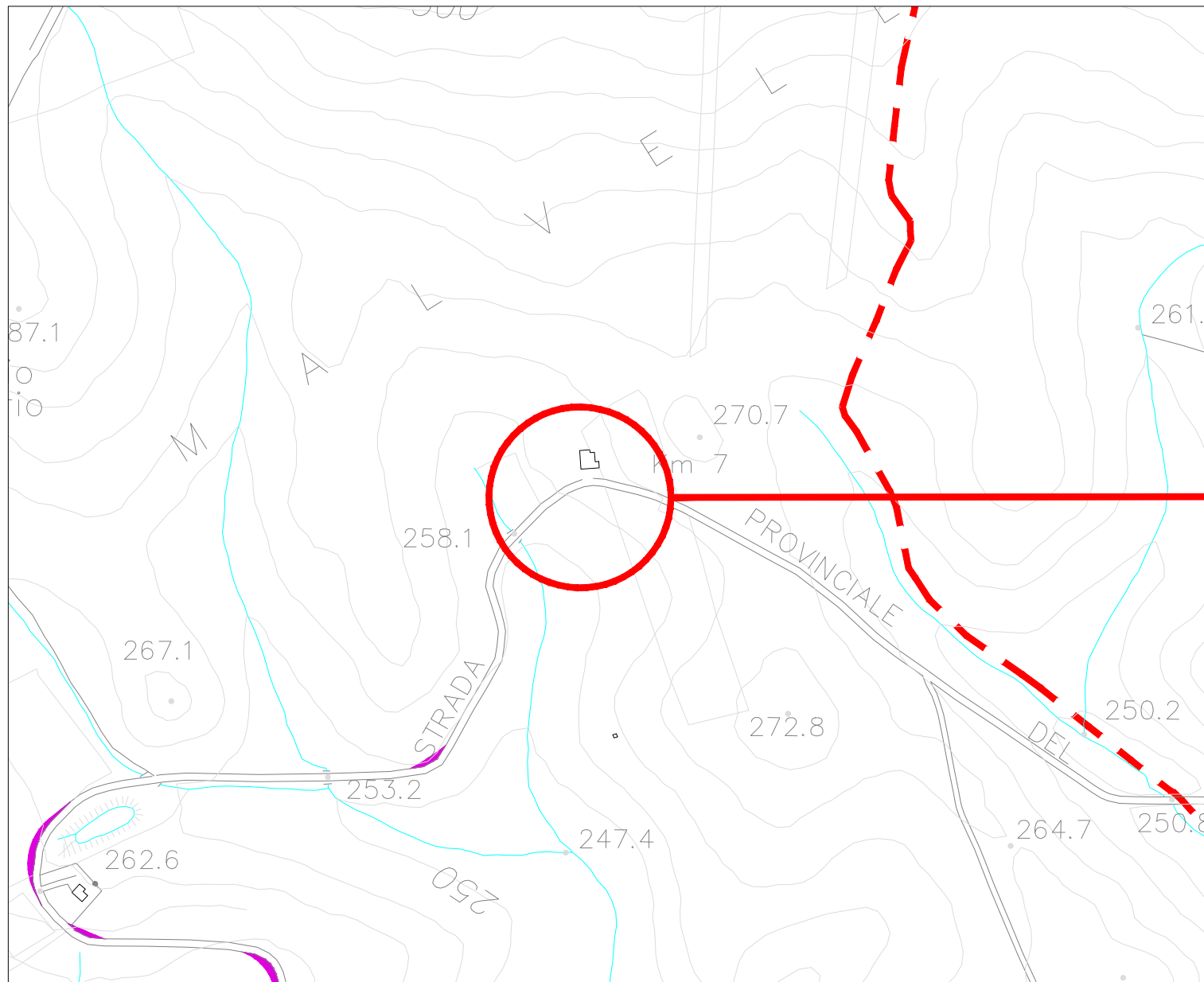

Planimetria catastale - Scala 1:1.000

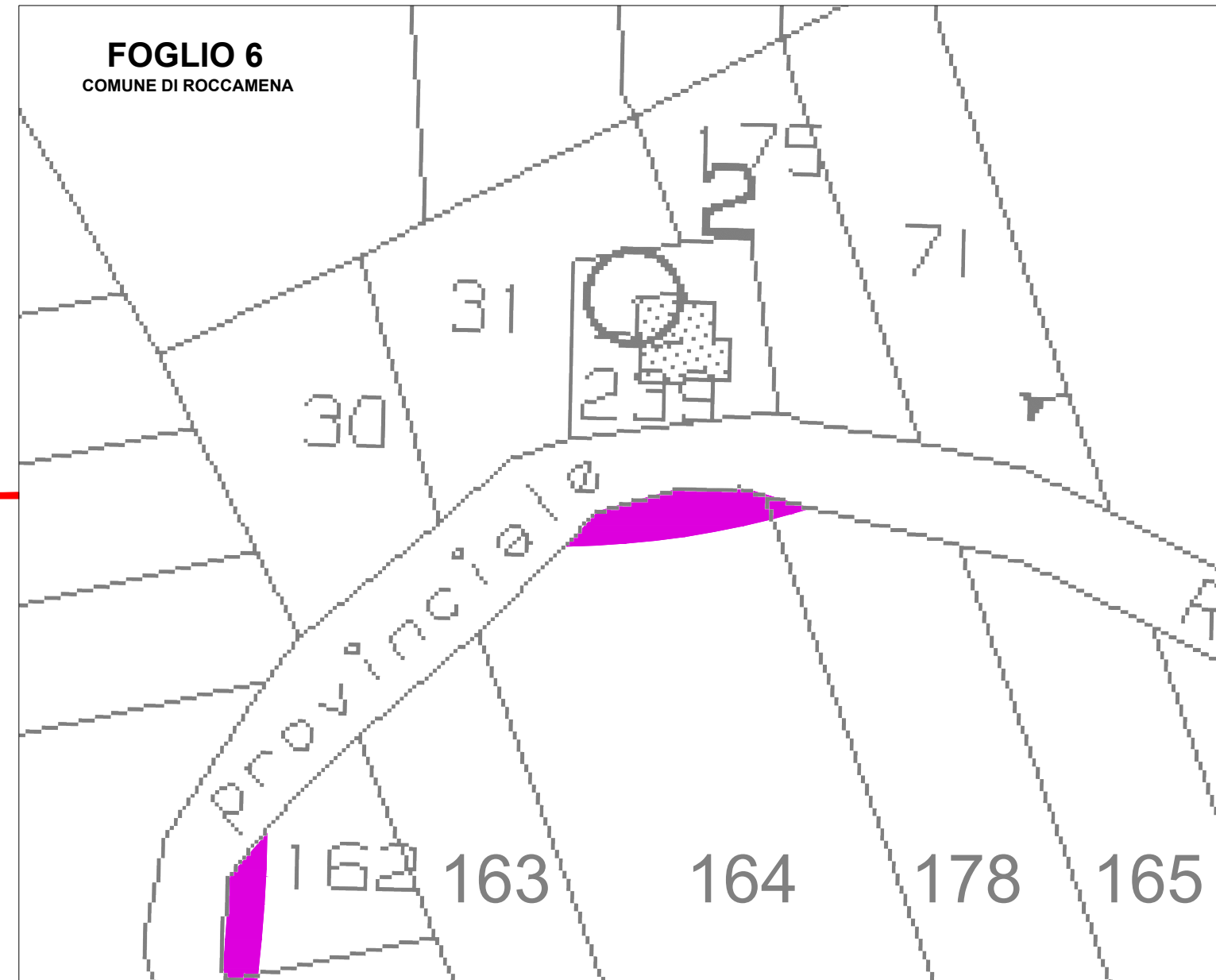

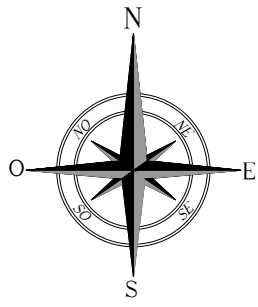

# INTERVENTI DI ADEGAMENTO VIABILITA' ESTERNA DI ACCESSO AL PARCO SU C.T.R. / CATASTALE

INT. 31





Comune di Roccamena F.M. 6 p.lla 33

STRADA PROVINCIALE N.45

lat. 37.837233°N

long. 13.198493°E

## LEGENDA

-  VIABILITA' ESISTENTE
-  AREA OCCUPAZIONE REVERSIBILE DI CANTIERE
-  AREA OCCUPAZIONE REVERSIBILE DI ESERCIZIO
-  AREA OCCUPAZIONE IRREVERSIBILE
-  CONFINE COMUNALE

Corografia – Scala 1:5.000

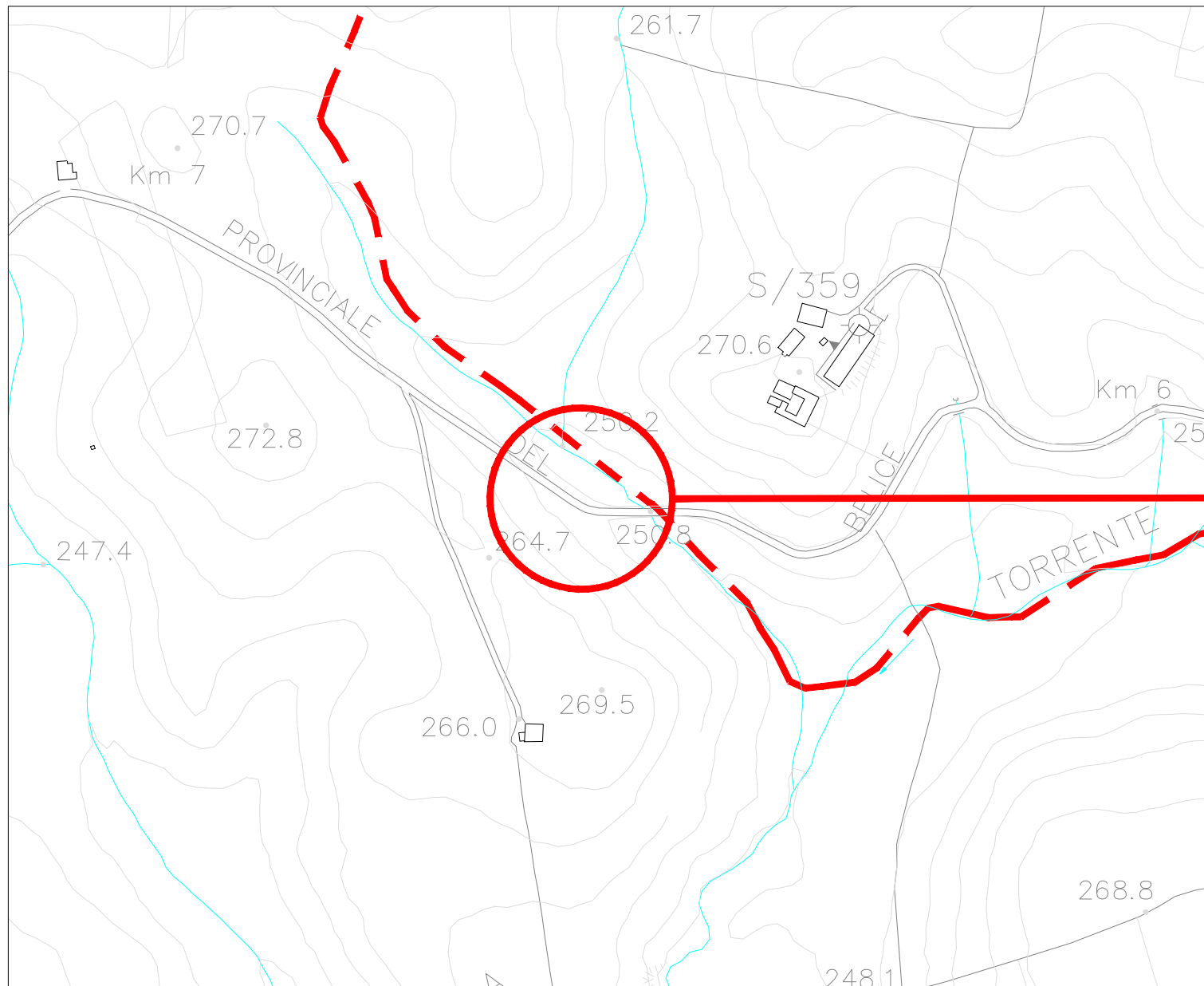

Planimetria catastale - Scala 1:1.000

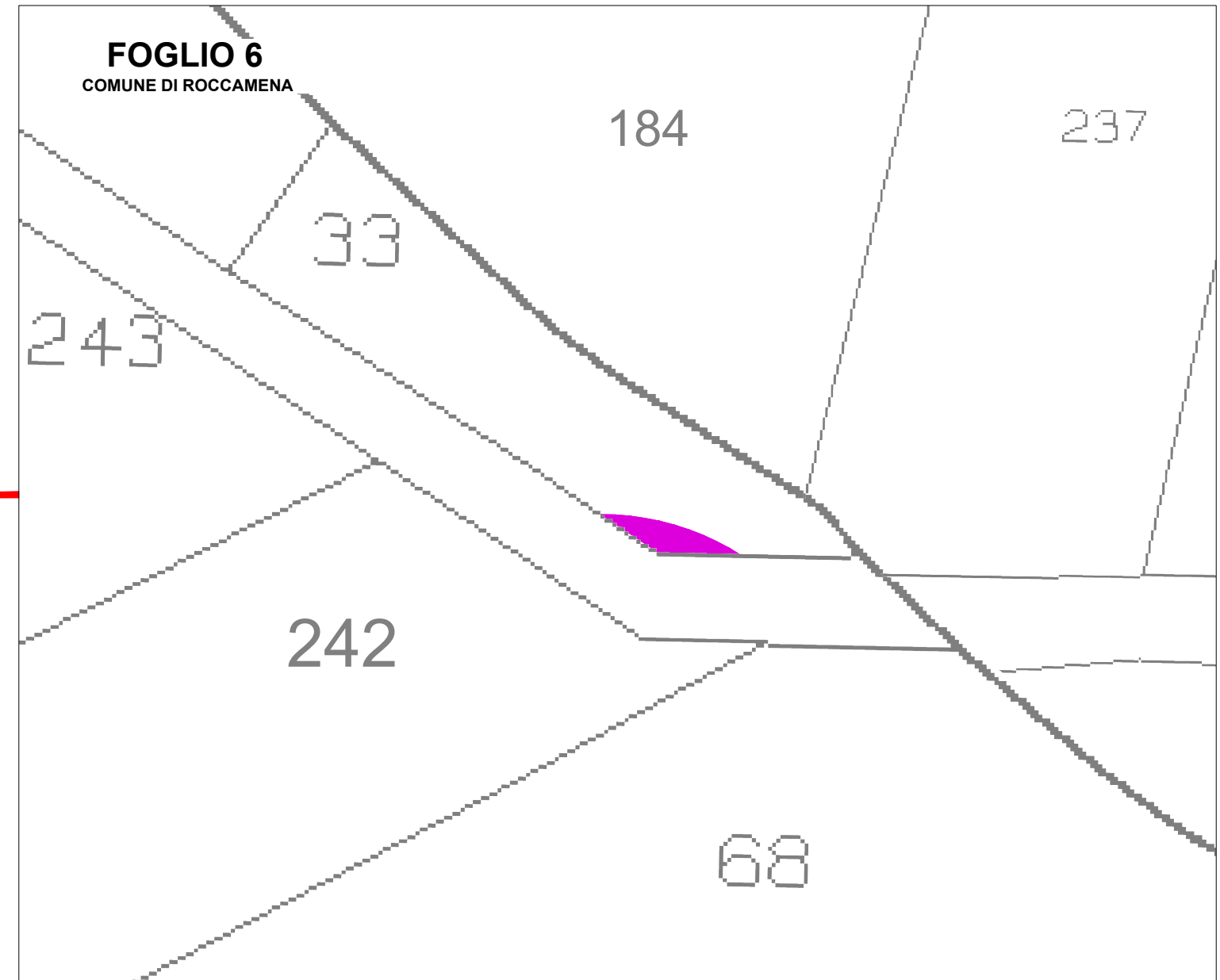

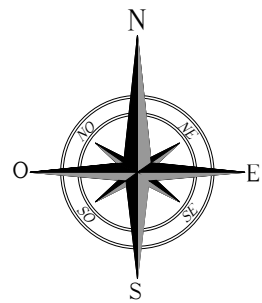

# INTERVENTI DI ADEGAMENTO VIABILITA' ESTERNA DI ACCESSO AL PARCO SU C.T.R. / CATASTALE





INT. 32

Comune di Corleone F.M. 24 p.lla 186

STRADA PROVINCIALE N.45

lat. 37.836957°N long. 13.200454°E

**LEGENDA**

-  VIABILITA' ESISTENTE
-  AREA OCCUPAZIONE REVERSIBILE DI CANTIERE
-  AREA OCCUPAZIONE REVERSIBILE DI ESERCIZIO
-  AREA OCCUPAZIONE IRREVERSIBILE
-  CONFINE COMUNALE

Corografia – Scala 1:5.000

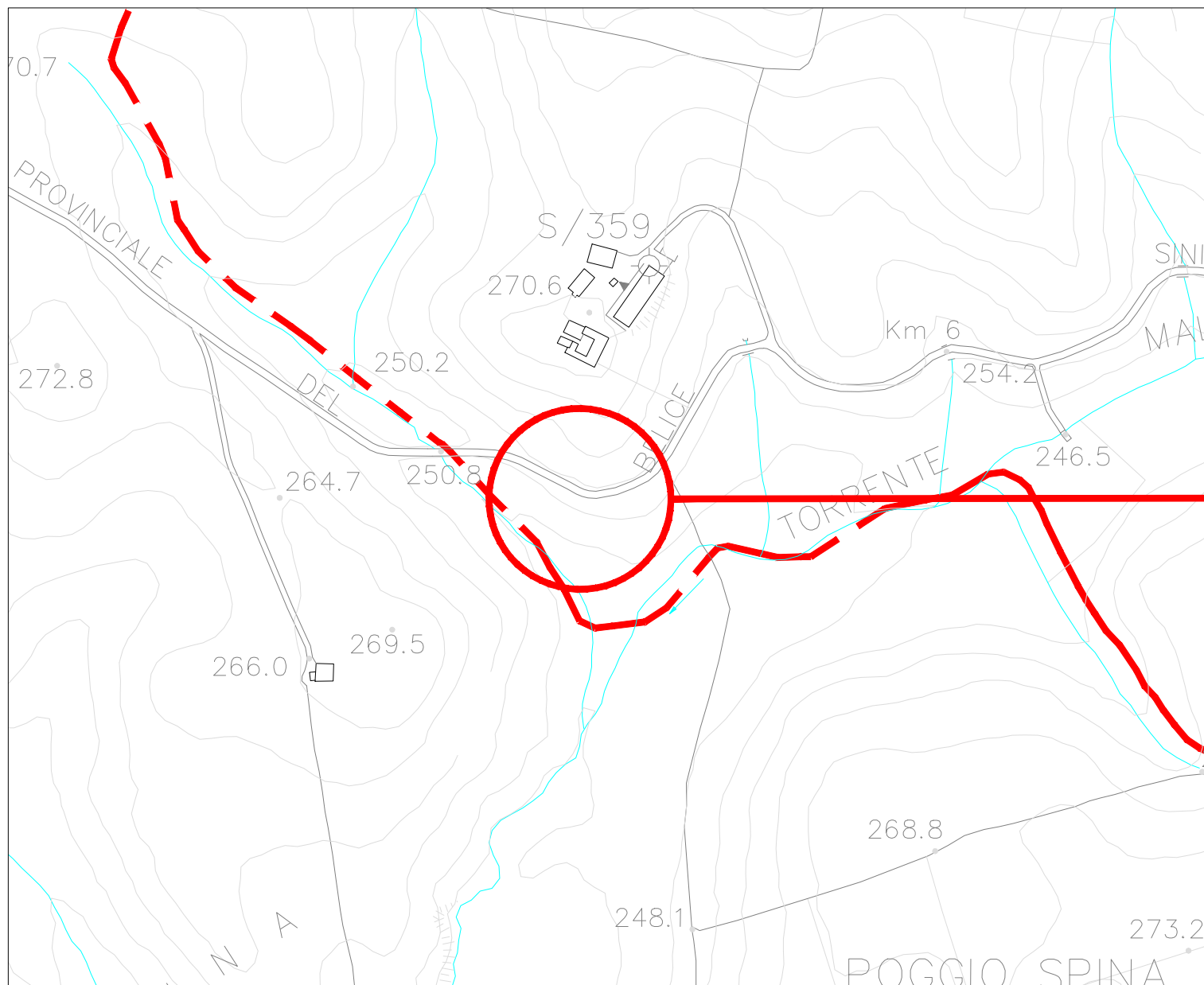

Planimetria catastale - Scala 1:1.000

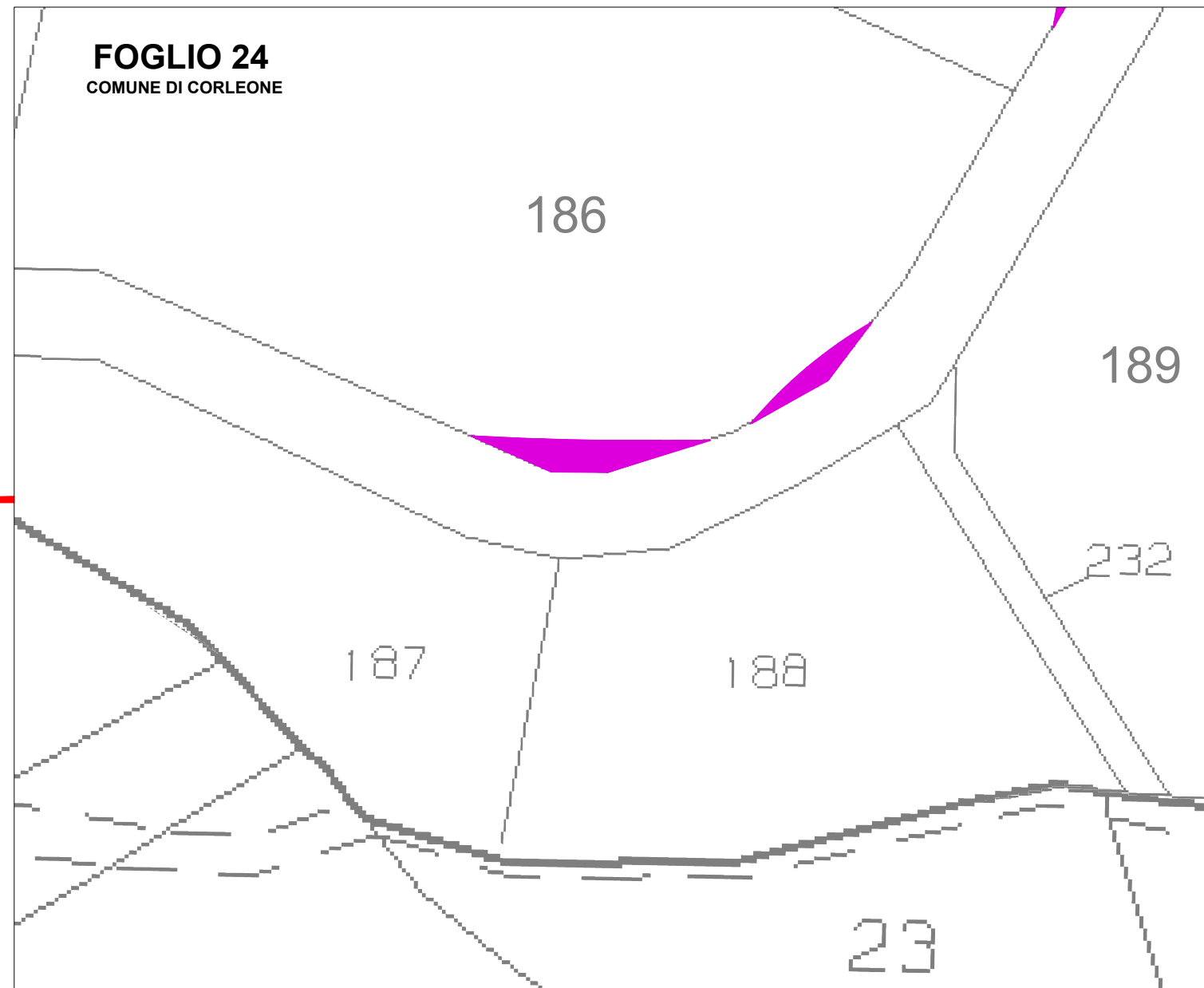



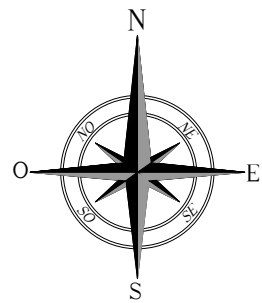

# INTERVENTI DI ADEGAMENTO VIABILITA' ESTERNA DI ACCESSO AL PARCO SU C.T.R. / CATASTALE

INT. 33





Comune di Corleone F.M. 24 p.lla 186

STRADA PROVINCIALE N.45

lat. 37.837173°N

long. 13.201006°E

**LEGENDA**

-  VIABILITA' ESISTENTE
-  AREA OCCUPAZIONE REVERSIBILE DI CANTIERE
-  AREA OCCUPAZIONE REVERSIBILE DI ESERCIZIO
-  AREA OCCUPAZIONE IRREVERSIBILE
-  CONFINE COMUNALE

Corografia – Scala 1:5.000

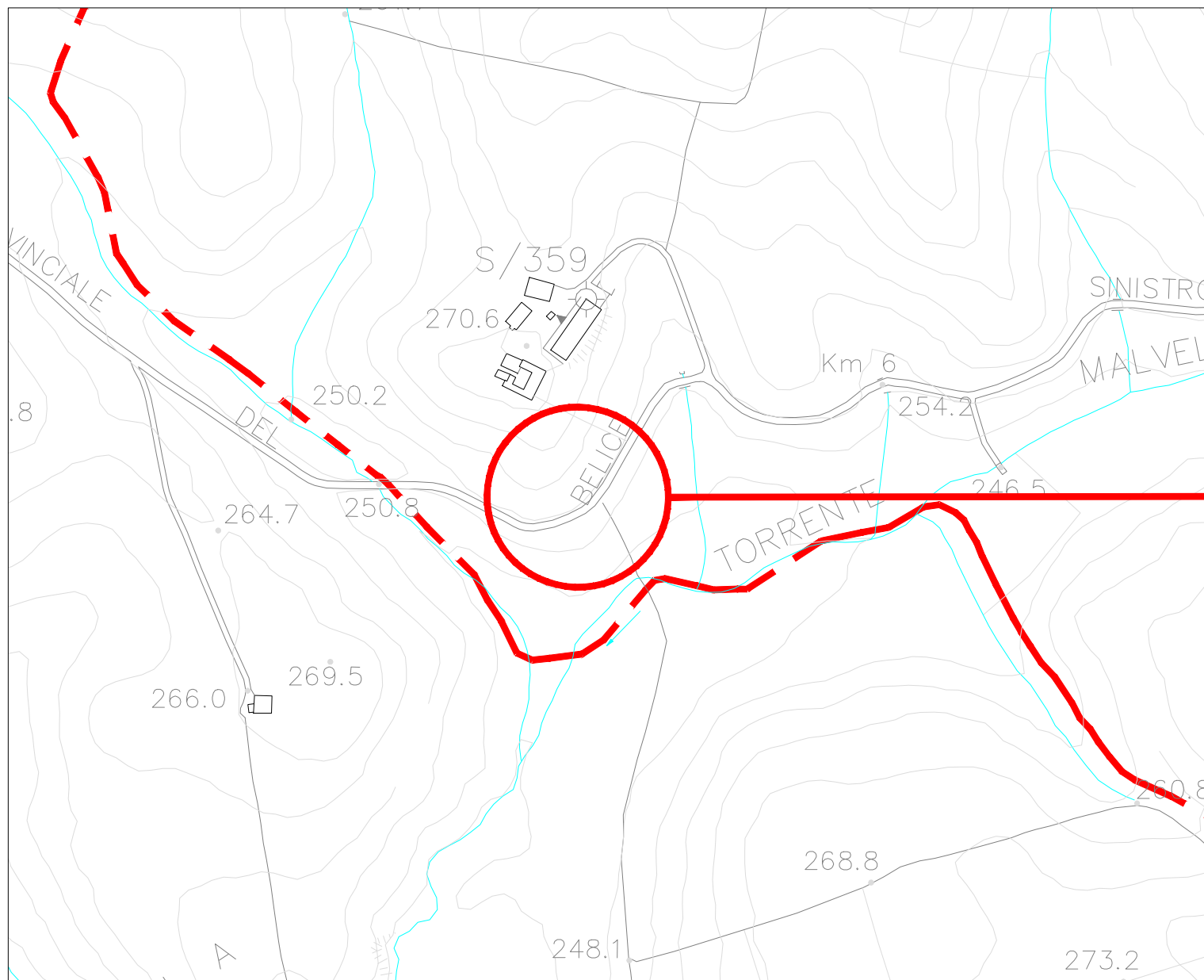

Planimetria catastale - Scala 1:1.000

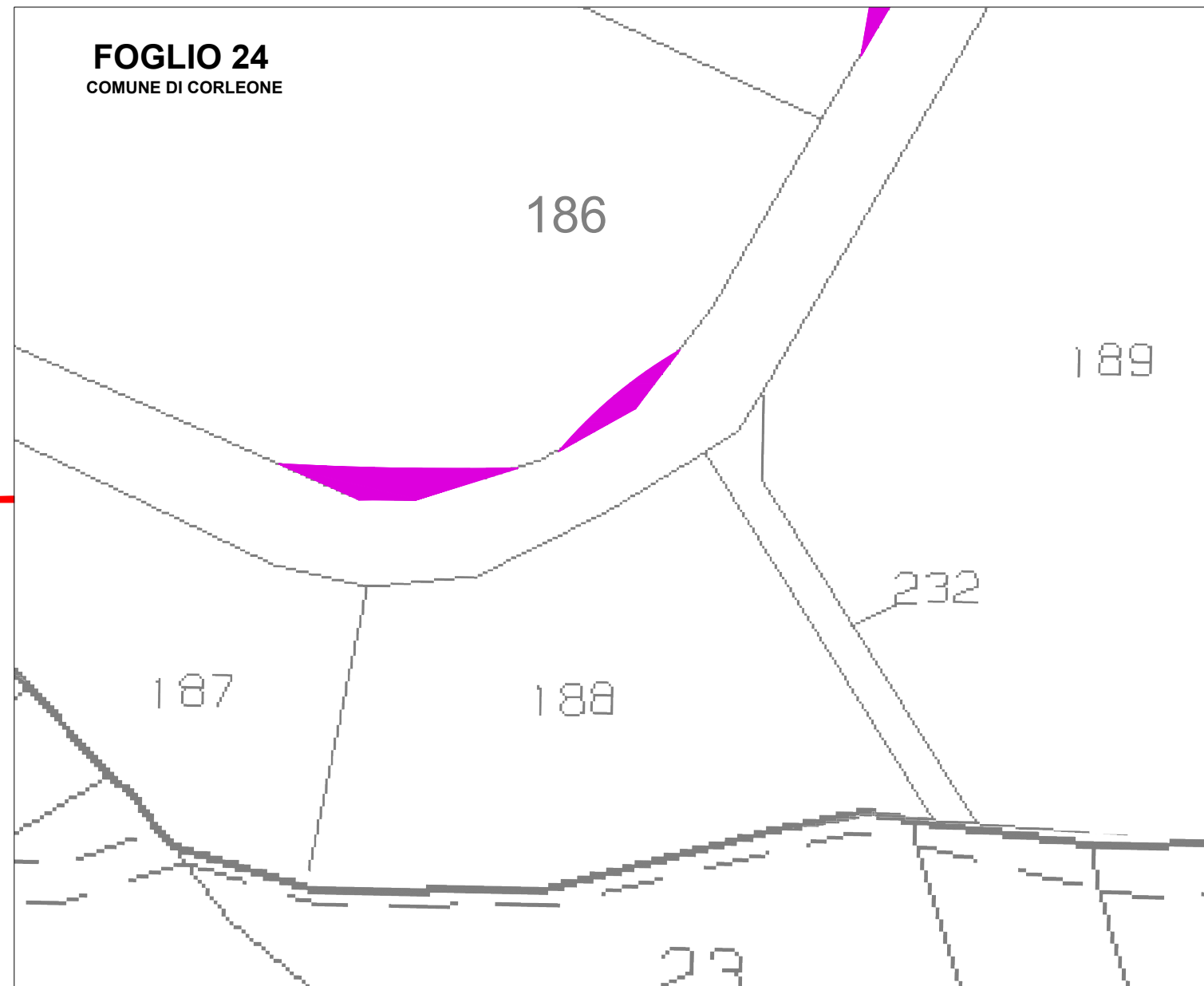

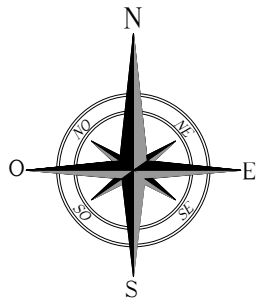

# INTERVENTI DI ADEGAMENTO VIABILITA' ESTERNA DI ACCESSO AL PARCO SU C.T.R. / CATASTALE





INT. 34

Comune di Corleone F.M. 24 p.lla 357

STRADA PROVINCIALE N.45

lat. 37.837982°N long. 13.201589°E

**LEGENDA**

-  VIABILITA' ESISTENTE
-  AREA OCCUPAZIONE REVERSIBILE DI CANTIERE
-  AREA OCCUPAZIONE REVERSIBILE DI ESERCIZIO
-  AREA OCCUPAZIONE IRREVERSIBILE
-  CONFINE COMUNALE

Corografia – Scala 1:5.000

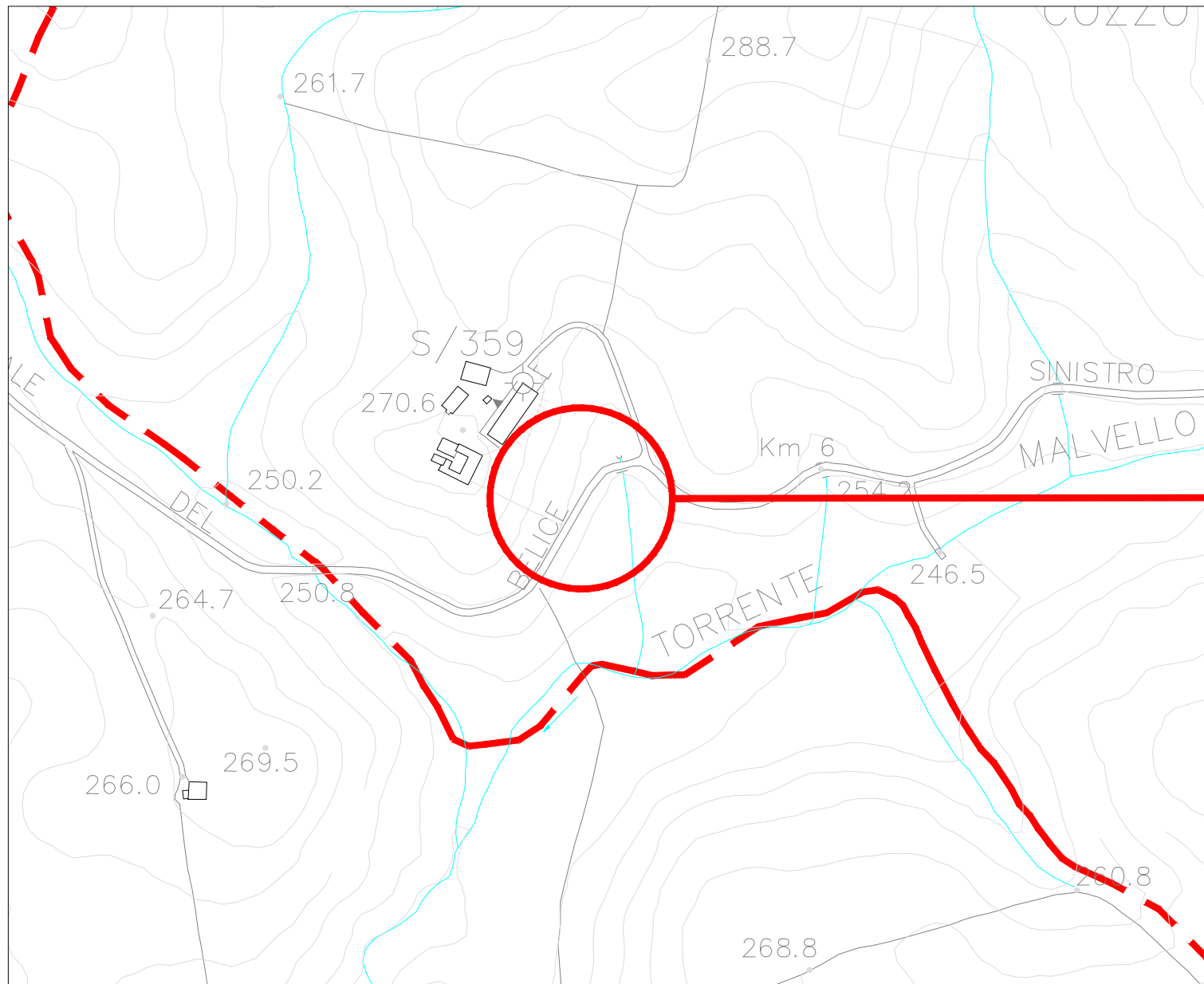

Planimetria catastale - Scala 1:1.000

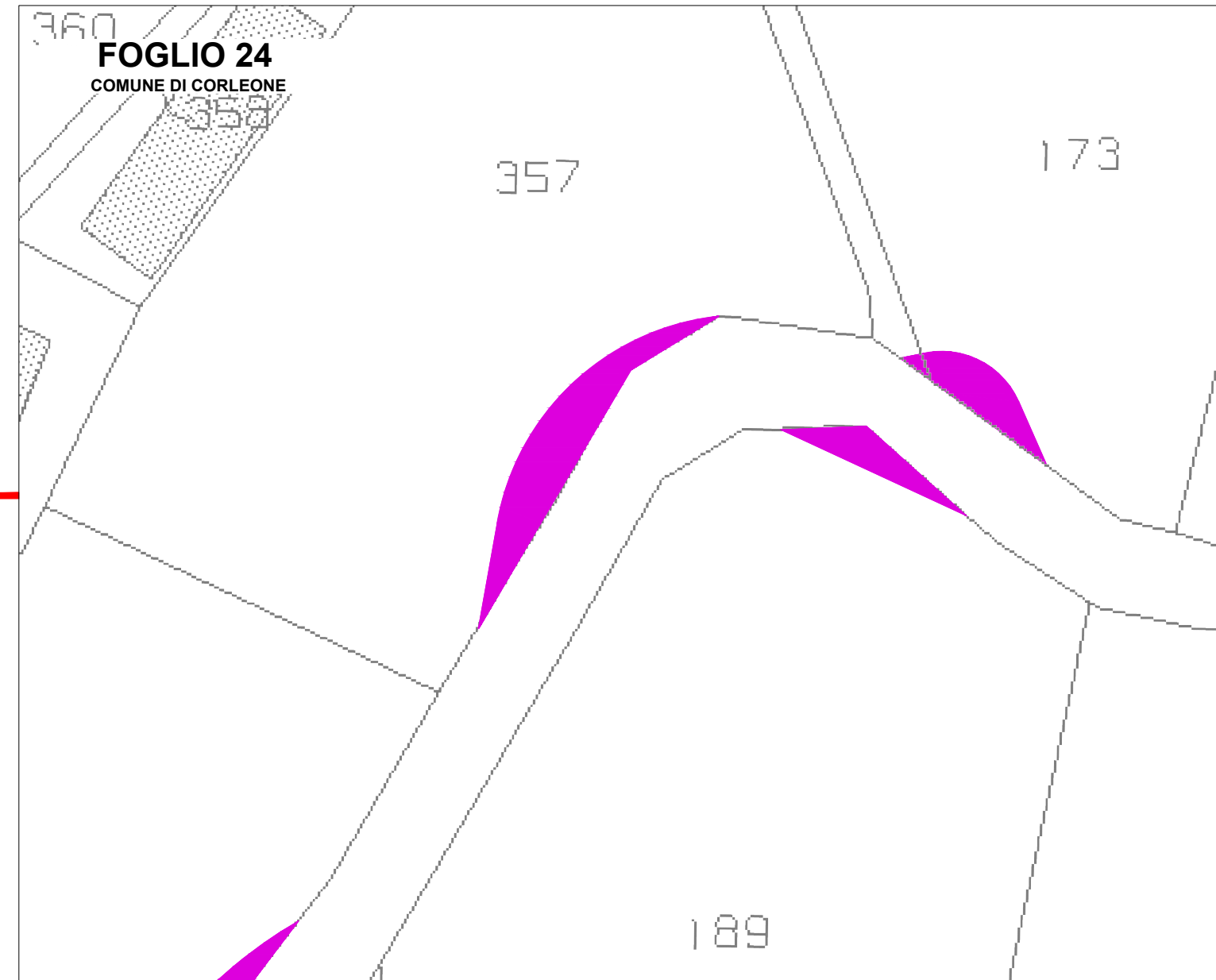

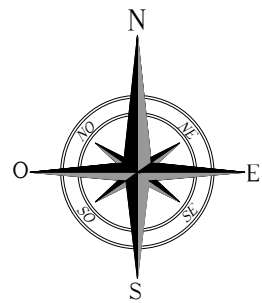

# INTERVENTI DI ADEGAMENTO VIABILITA' ESTERNA DI ACCESSO AL PARCO SU C.T.R. / CATASTALE





INT. 35

Comune di Corleone F.M. 24 p.lla 189

STRADA PROVINCIALE N.45

lat. 37.838000°N long. 13.202080°E

**LEGENDA**

-  VIABILITA' ESISTENTE
-  AREA OCCUPAZIONE REVERSIBILE DI CANTIERE
-  AREA OCCUPAZIONE REVERSIBILE DI ESERCIZIO
-  AREA OCCUPAZIONE IRREVERSIBILE
-  CONFINE COMUNALE

Corografia – Scala 1:5.000

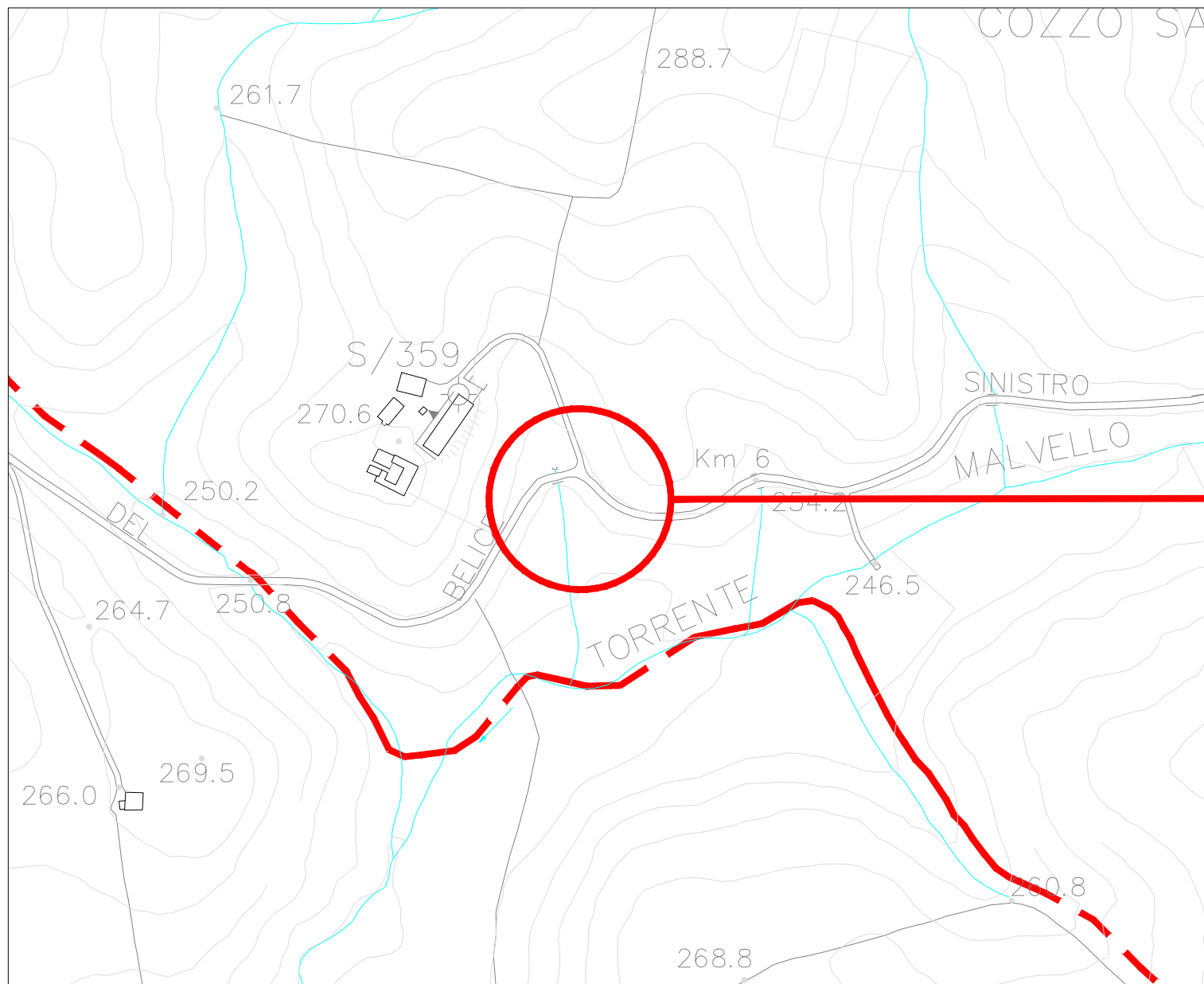

Planimetria catastale - Scala 1:1.000

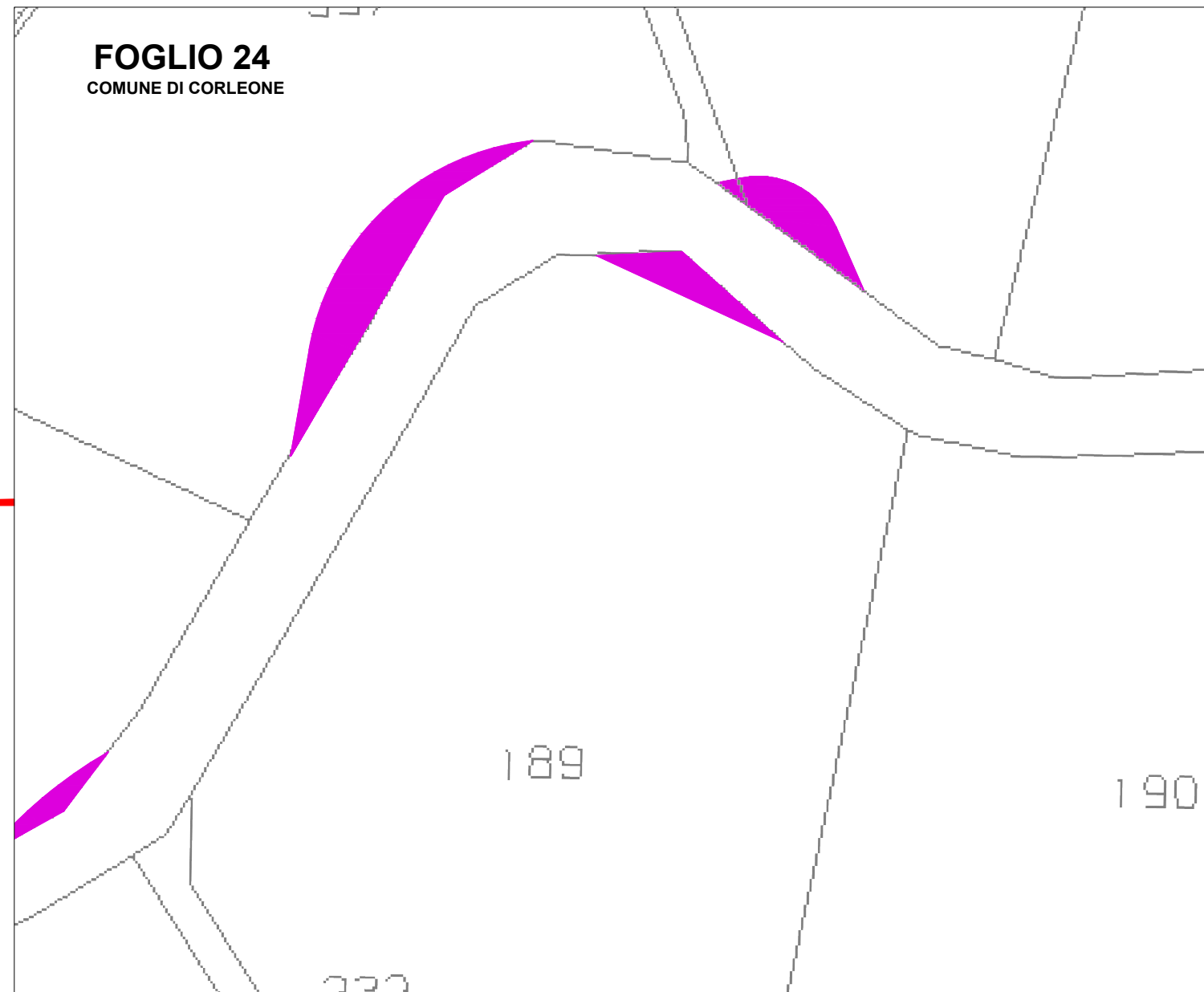

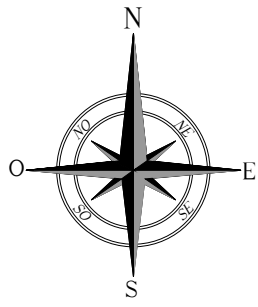

# INTERVENTI DI ADEGAMENTO VIABILITA' ESTERNA DI ACCESSO AL PARCO SU C.T.R. / CATASTALE





INT. 36

Comune di Corleone F.M. 24 p.lla 173

STRADA PROVINCIALE N.45

lat. 37.838052°N long. 13.202250°E

**LEGENDA**

-  VIABILITA' ESISTENTE
-  AREA OCCUPAZIONE REVERSIBILE DI CANTIERE
-  AREA OCCUPAZIONE REVERSIBILE DI ESERCIZIO
-  AREA OCCUPAZIONE IRREVERSIBILE
-  CONFINE COMUNALE

Corografia – Scala 1:5.000

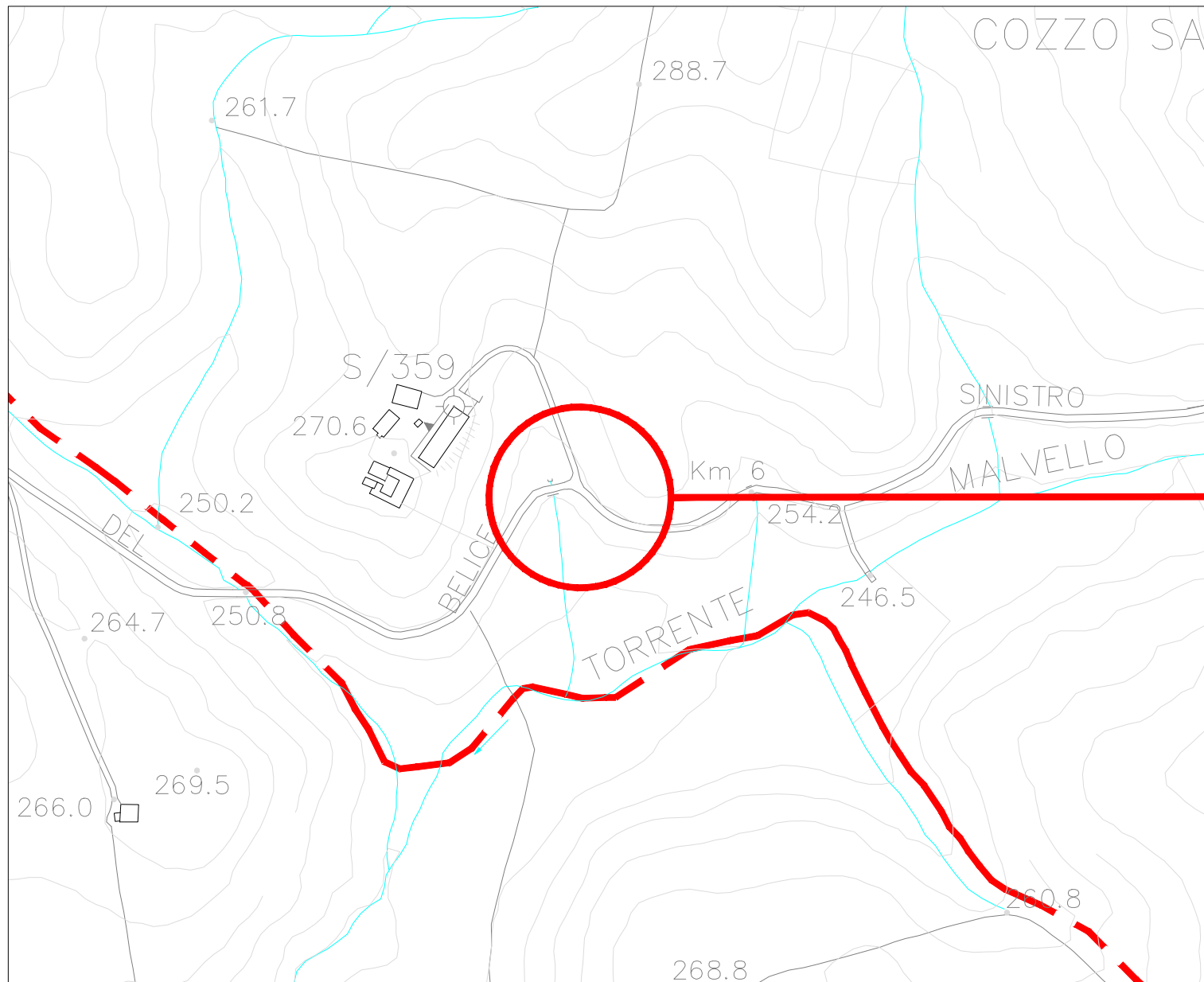

Planimetria catastale - Scala 1:1.000

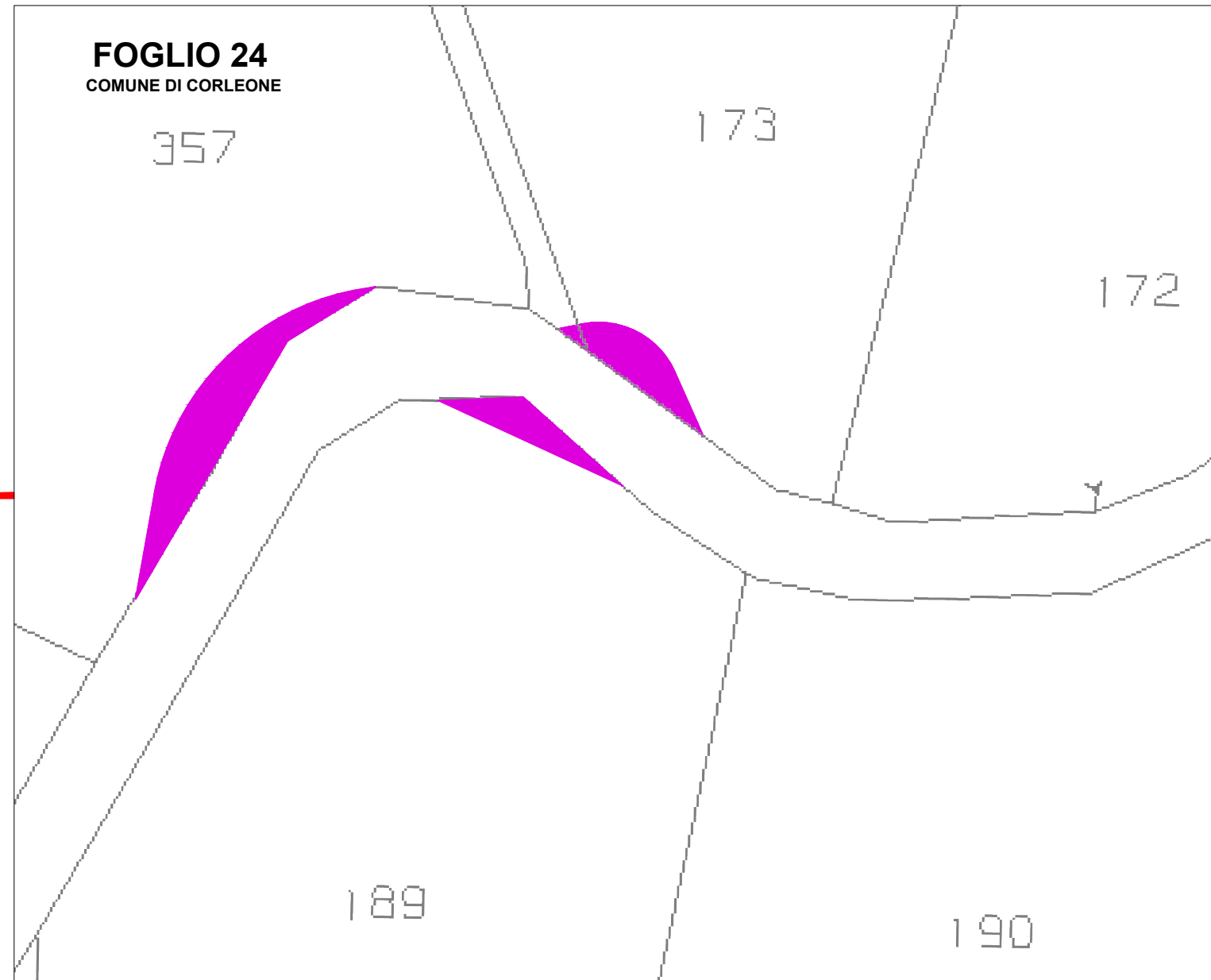

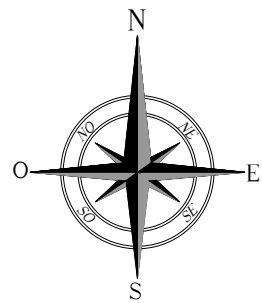

# INTERVENTI DI ADEGAMENTO VIABILITA' ESTERNA DI ACCESSO AL PARCO SU C.T.R. / CATASTALE

INT. 37

Comune di Corleone F.M. 24 p.lle 190, 191

STRADA PROVINCIALE N.45

lat. 37.838008°N long. 13.203803°E

**LEGENDA**

- VIABILITA' ESISTENTE
- AREA OCCUPAZIONE REVERSIBILE DI CANTIERE
- AREA OCCUPAZIONE REVERSIBILE DI ESERCIZIO
- AREA OCCUPAZIONE IRREVERSIBILE
- CONFINE COMUNALE

Corografia – Scala 1:5.000

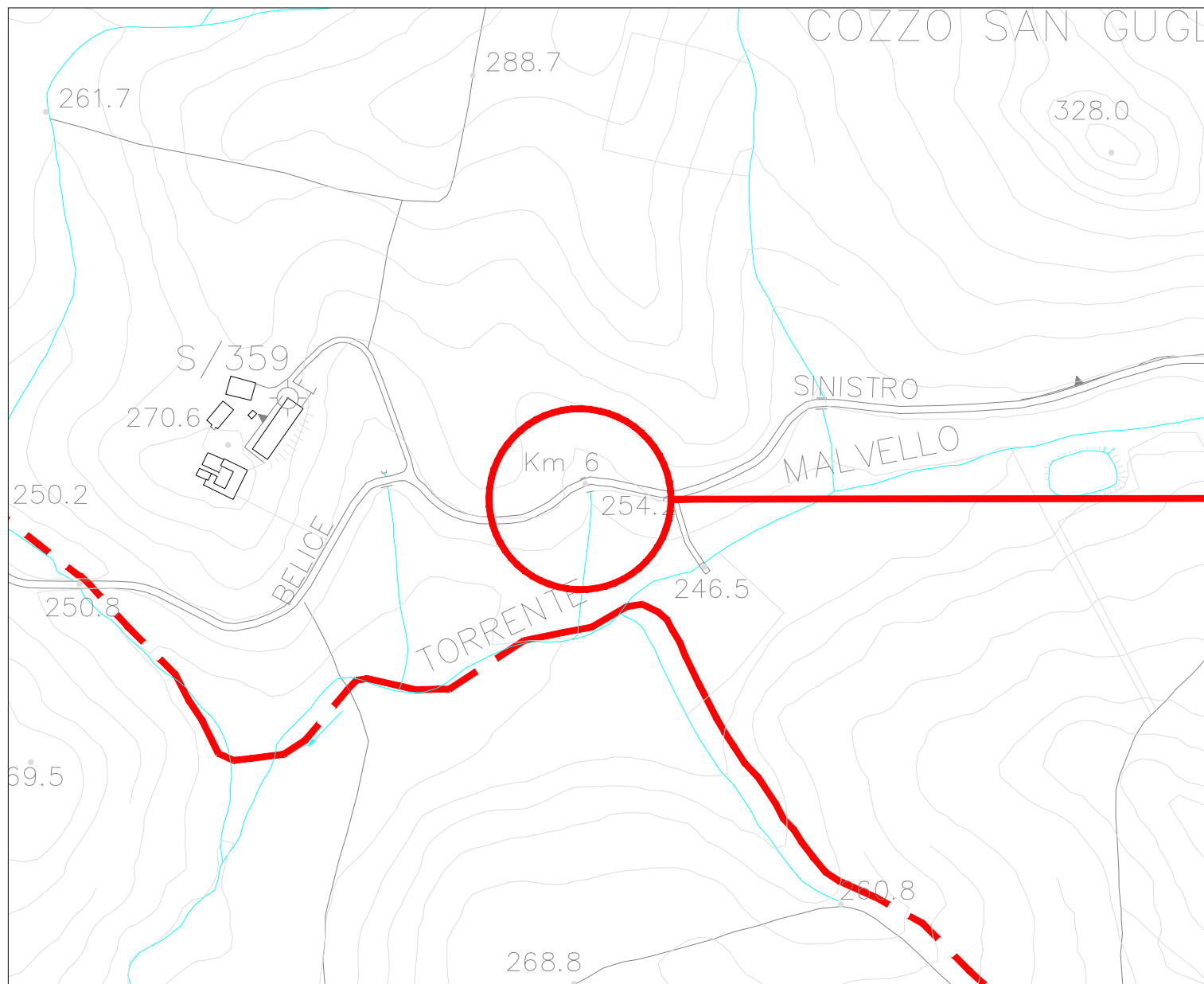

Planimetria catastale - Scala 1:1.000

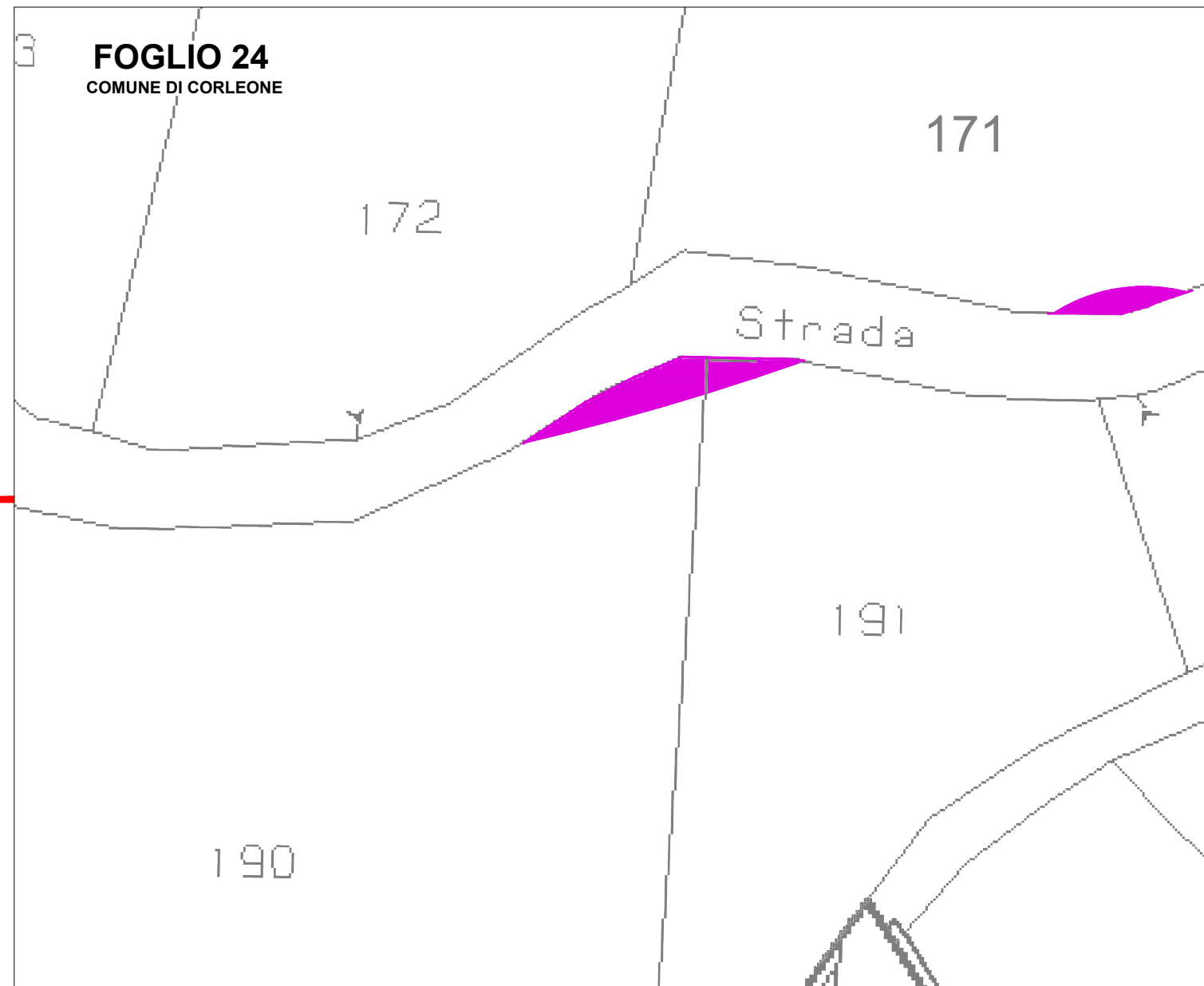

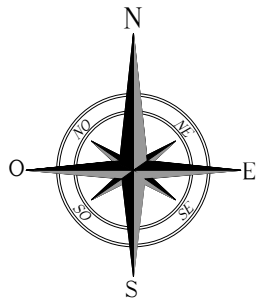

# INTERVENTI DI ADEGAMENTO VIABILITA' ESTERNA DI ACCESSO AL PARCO SU C.T.R. / CATASTALE





INT. 38

Comune di Corleone F.M. 24 p.lla 171

STRADA PROVINCIALE N.45

lat. 37.838012°N long. 13.204633°E

**LEGENDA**

-  VIABILITA' ESISTENTE
-  AREA OCCUPAZIONE REVERSIBILE DI CANTIERE
-  AREA OCCUPAZIONE REVERSIBILE DI ESERCIZIO
-  AREA OCCUPAZIONE IRREVERSIBILE
-  CONFINE COMUNALE

Corografia – Scala 1:5.000

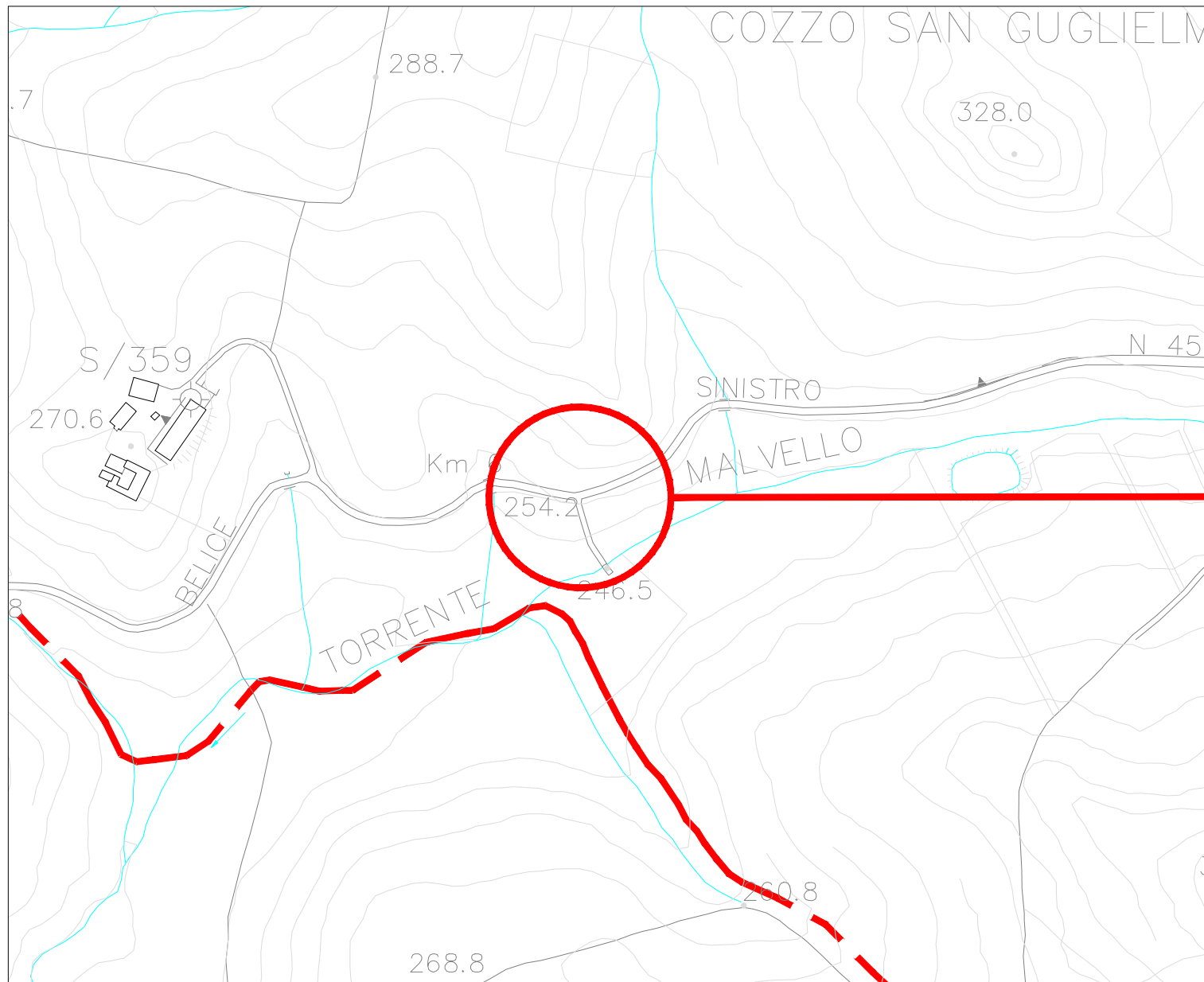

Planimetria catastale - Scala 1:1.000

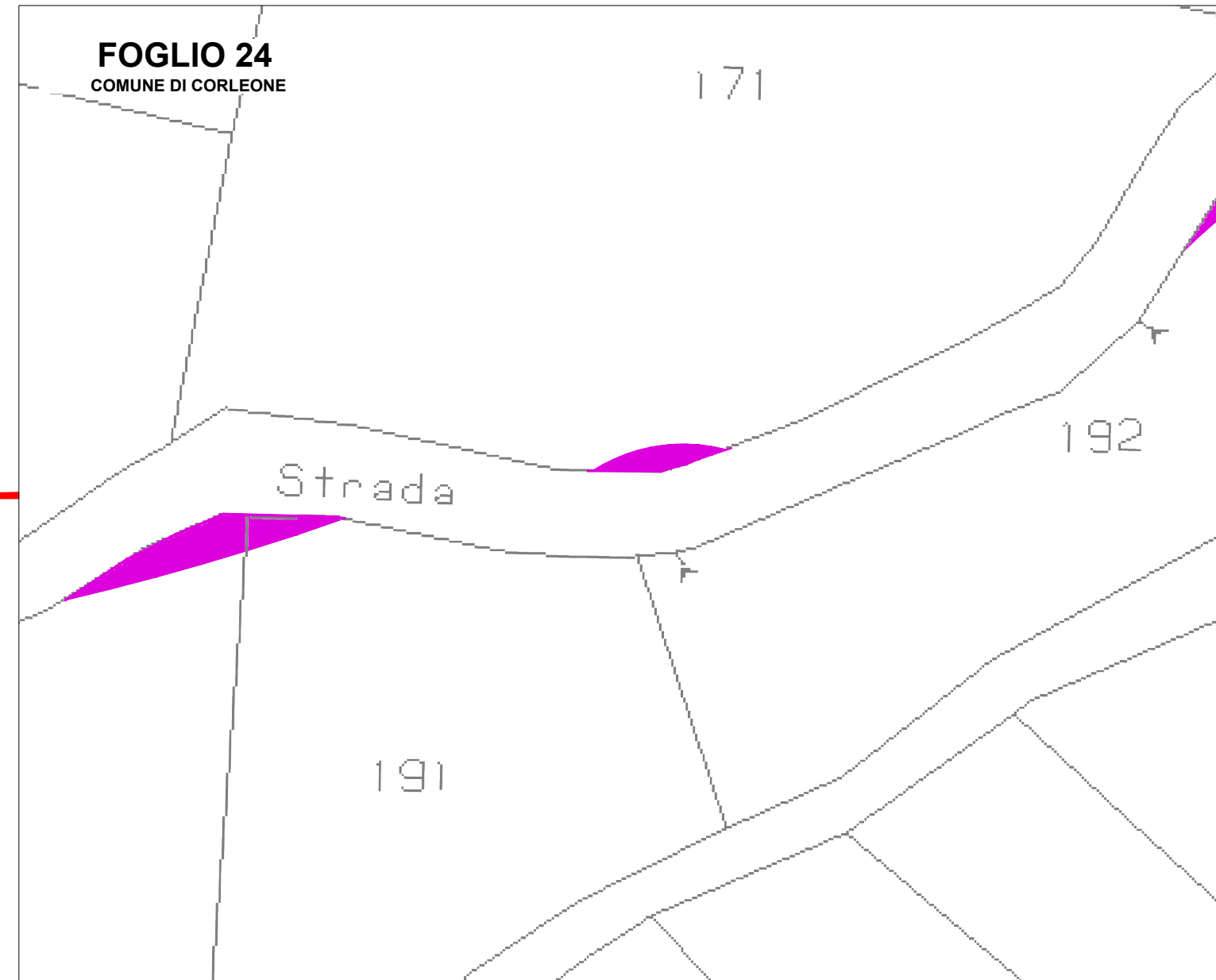

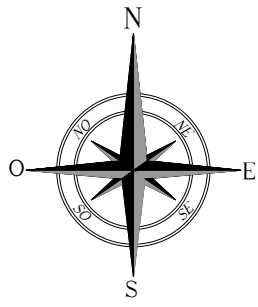

# INTERVENTI DI ADEGAMENTO VIABILITA' ESTERNA DI ACCESSO AL PARCO SU C.T.R. / CATASTALE

INT. 39

Comune di Corleone F.M. 24 p.lle 192, 230

STRADA PROVINCIALE N.45

lat. 37.838643°N long. 13.205833°E

**LEGENDA**

- VIABILITA' ESISTENTE
- AREA OCCUPAZIONE REVERSIBILE DI CANTIERE
- AREA OCCUPAZIONE REVERSIBILE DI ESERCIZIO
- AREA OCCUPAZIONE IRREVERSIBILE
- CONFINE COMUNALE

Corografia – Scala 1:5.000

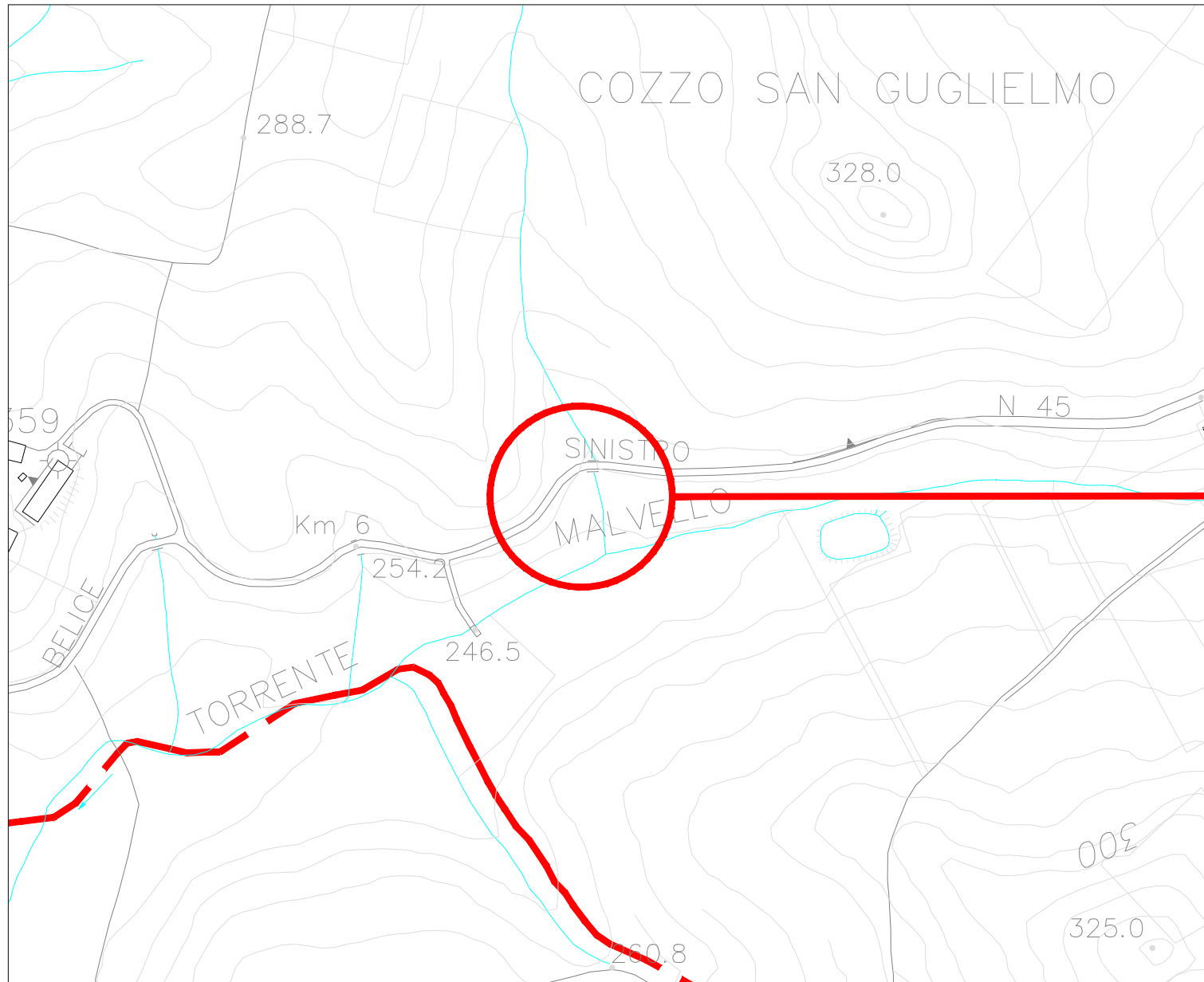

Planimetria catastale - Scala 1:1.000

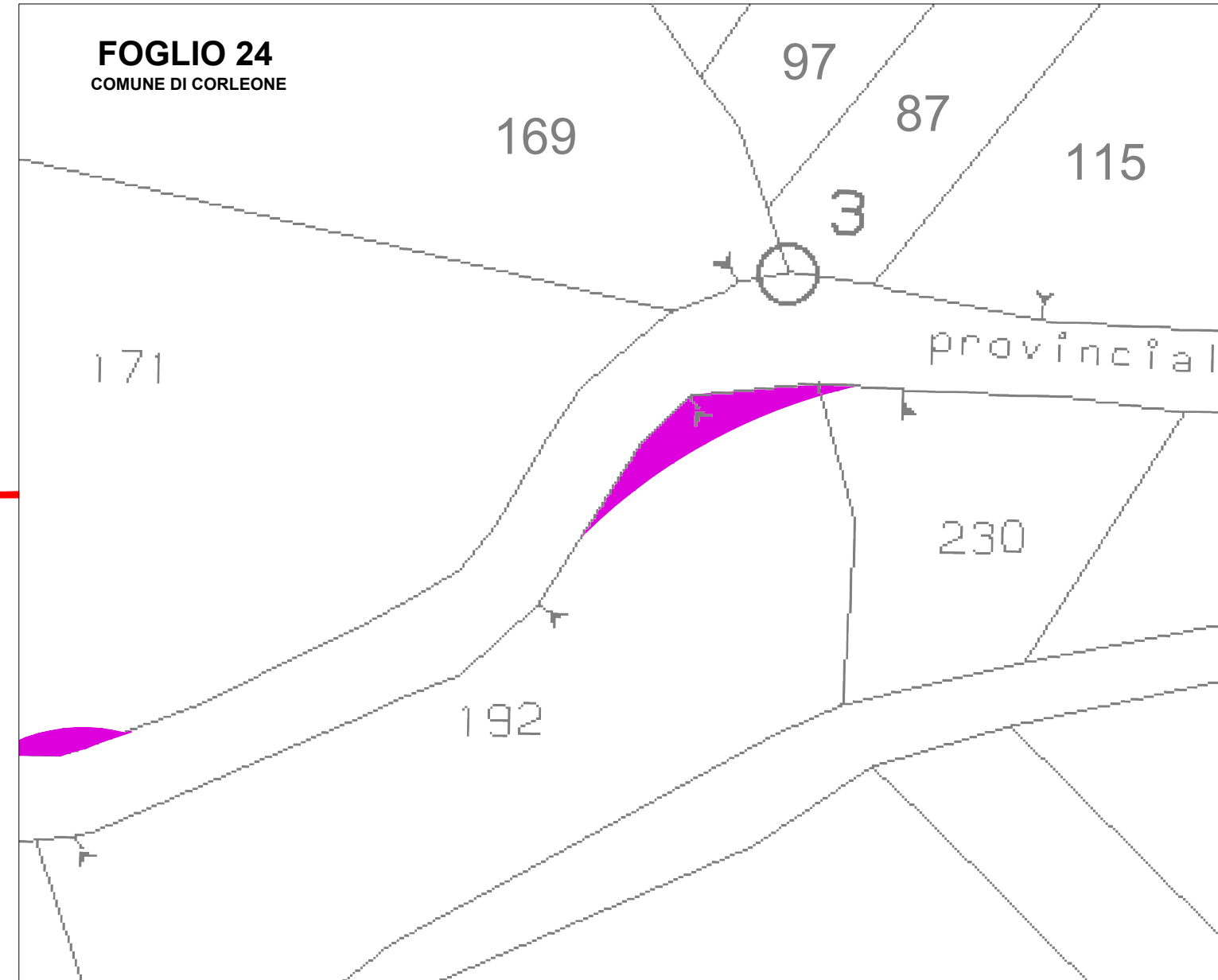

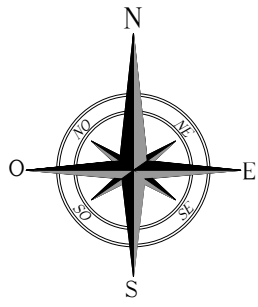

# INTERVENTI DI ADEGAMENTO VIABILITA' ESTERNA DI ACCESSO AL PARCO SU C.T.R. / CATASTALE





INT. 40

Comune di Corleone F.M. 23 p.lla 124

incrocio tra STRADA PROVINCIALE N.45 con EX C.LE n.49

lat. 37.836297°N long. 13.231867°E

**LEGENDA**

-  VIABILITA' ESISTENTE
-  AREA OCCUPAZIONE REVERSIBILE DI CANTIERE
-  AREA OCCUPAZIONE REVERSIBILE DI ESERCIZIO
-  AREA OCCUPAZIONE IRREVERSIBILE
-  CONFINE COMUNALE

Corografia – Scala 1:5.000

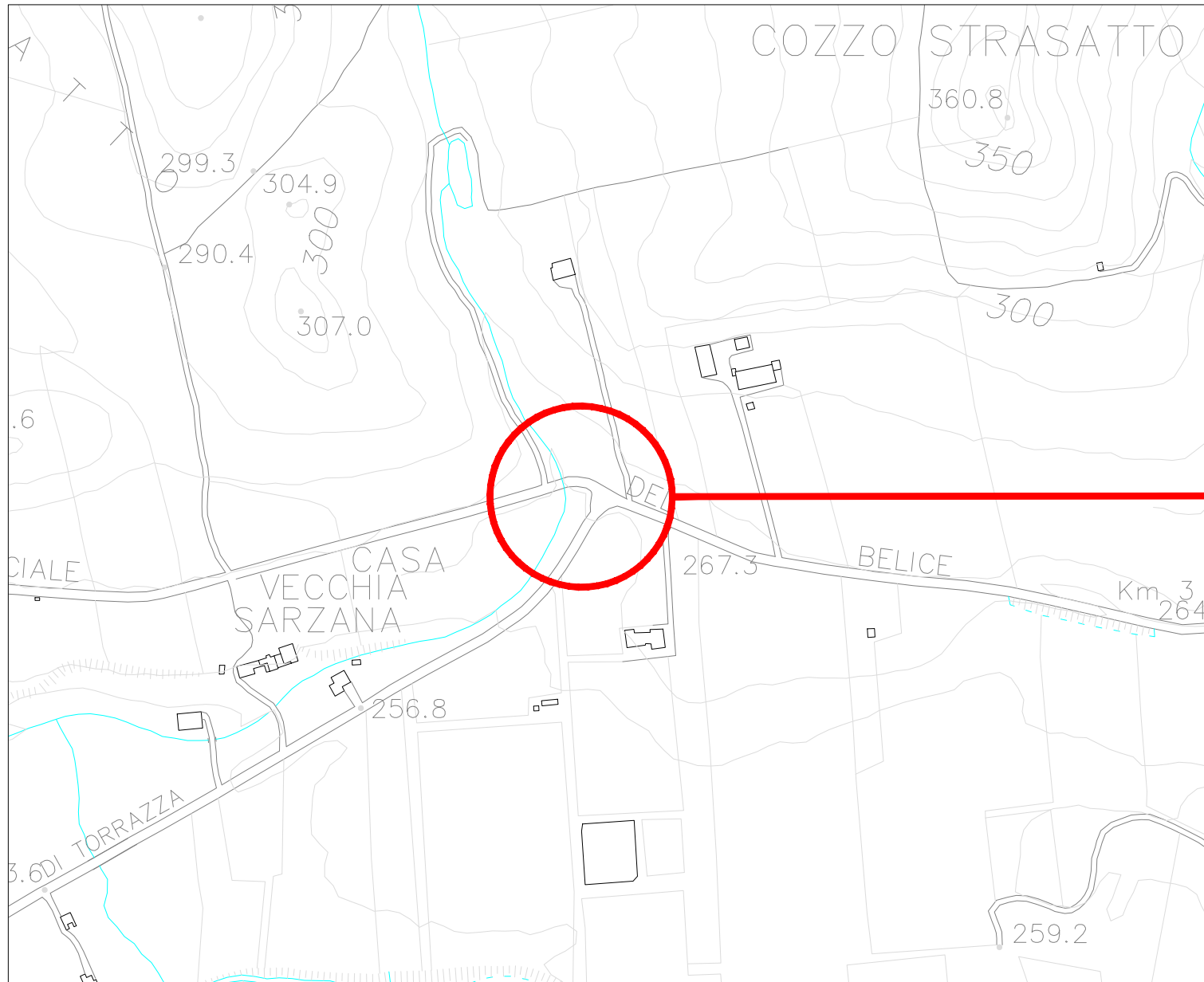

Planimetria catastale - Scala 1:1.000

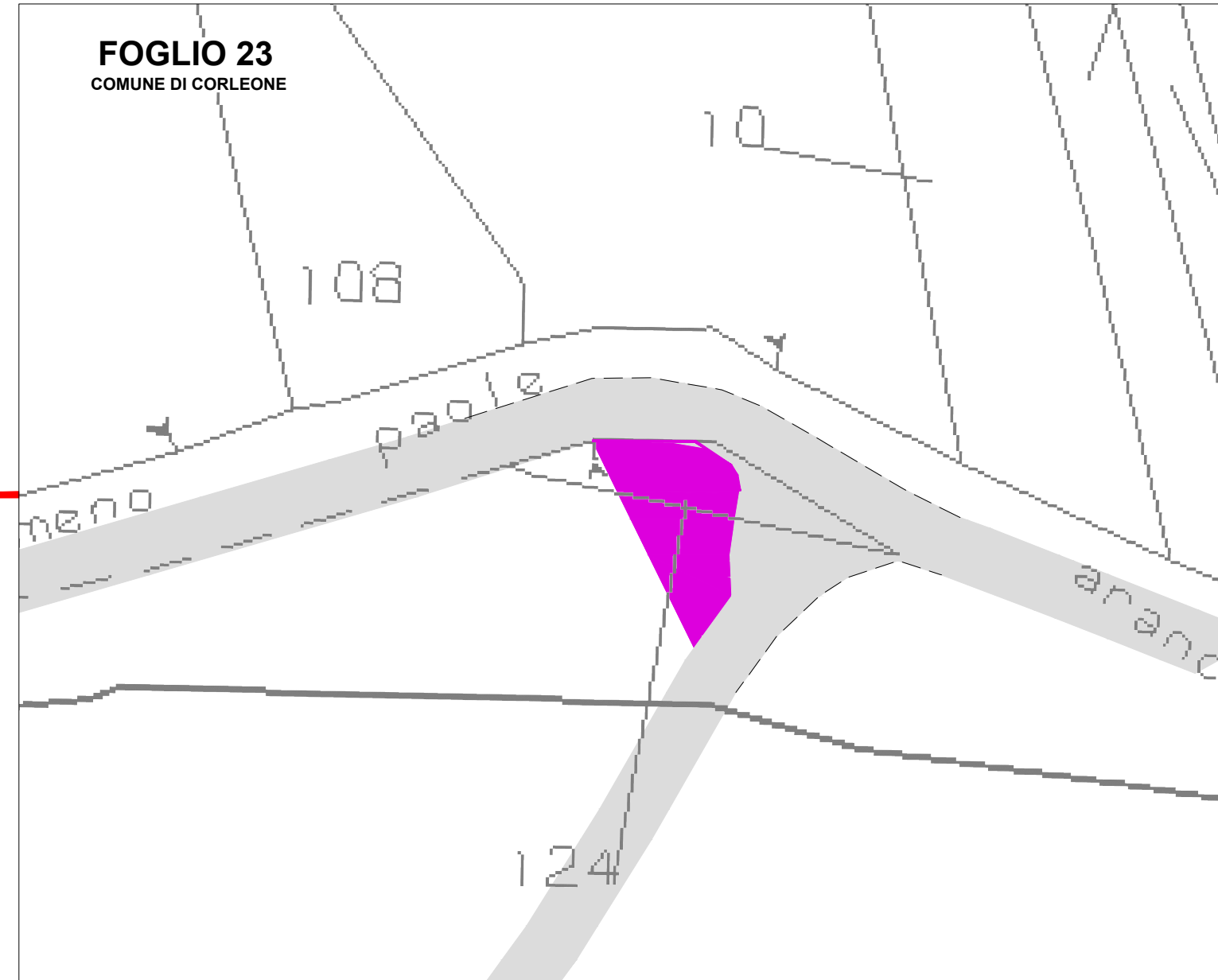



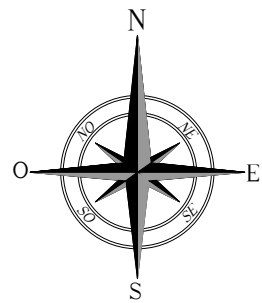

# INTERVENTI DI ADEGAMENTO VIABILITA' ESTERNA DI ACCESSO AL PARCO SU C.T.R. / CATASTALE





INT. 41

Comune di Corleone F.M. 44 p.IIa 6

STRADA PROVINCIALE N.97

lat. 37.817824°N long. 13.207508°E

**LEGENDA**

-  VIABILITA' ESISTENTE
-  AREA OCCUPAZIONE REVERSIBILE DI CANTIERE
-  AREA OCCUPAZIONE REVERSIBILE DI ESERCIZIO
-  AREA OCCUPAZIONE IRREVERSIBILE
-  CONFINE COMUNALE

Corografia – Scala 1:5.000

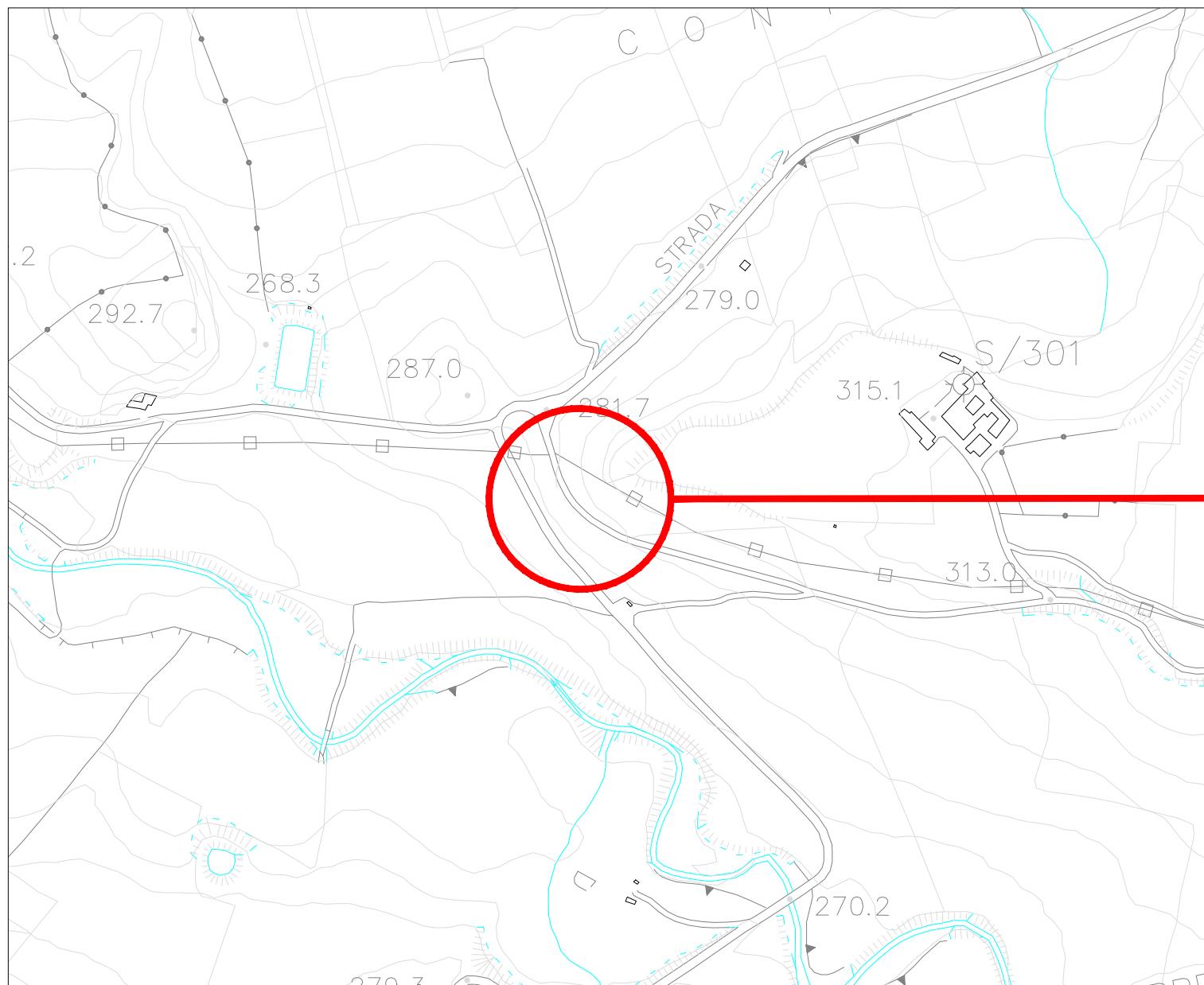

Planimetria catastale - Scala 1:1.000



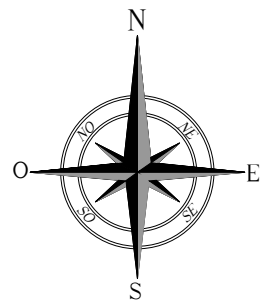

# INTERVENTI DI ADEGAMENTO VIABILITA' ESTERNA DI ACCESSO AL PARCO SU C.T.R. / CATASTALE





INT. 42

Comune di Corleone F.M. 44 p.lle 23, 112

STRADA PROVINCIALE N.97

lat. 37.816815°N long. 13.212860°E

## LEGENDA

-  VIABILITA' ESISTENTE
-  AREA OCCUPAZIONE REVERSIBILE DI CANTIERE
-  AREA OCCUPAZIONE REVERSIBILE DI ESERCIZIO
-  AREA OCCUPAZIONE IRREVERSIBILE
-  CONFINE COMUNALE

Corografia – Scala 1:5.000

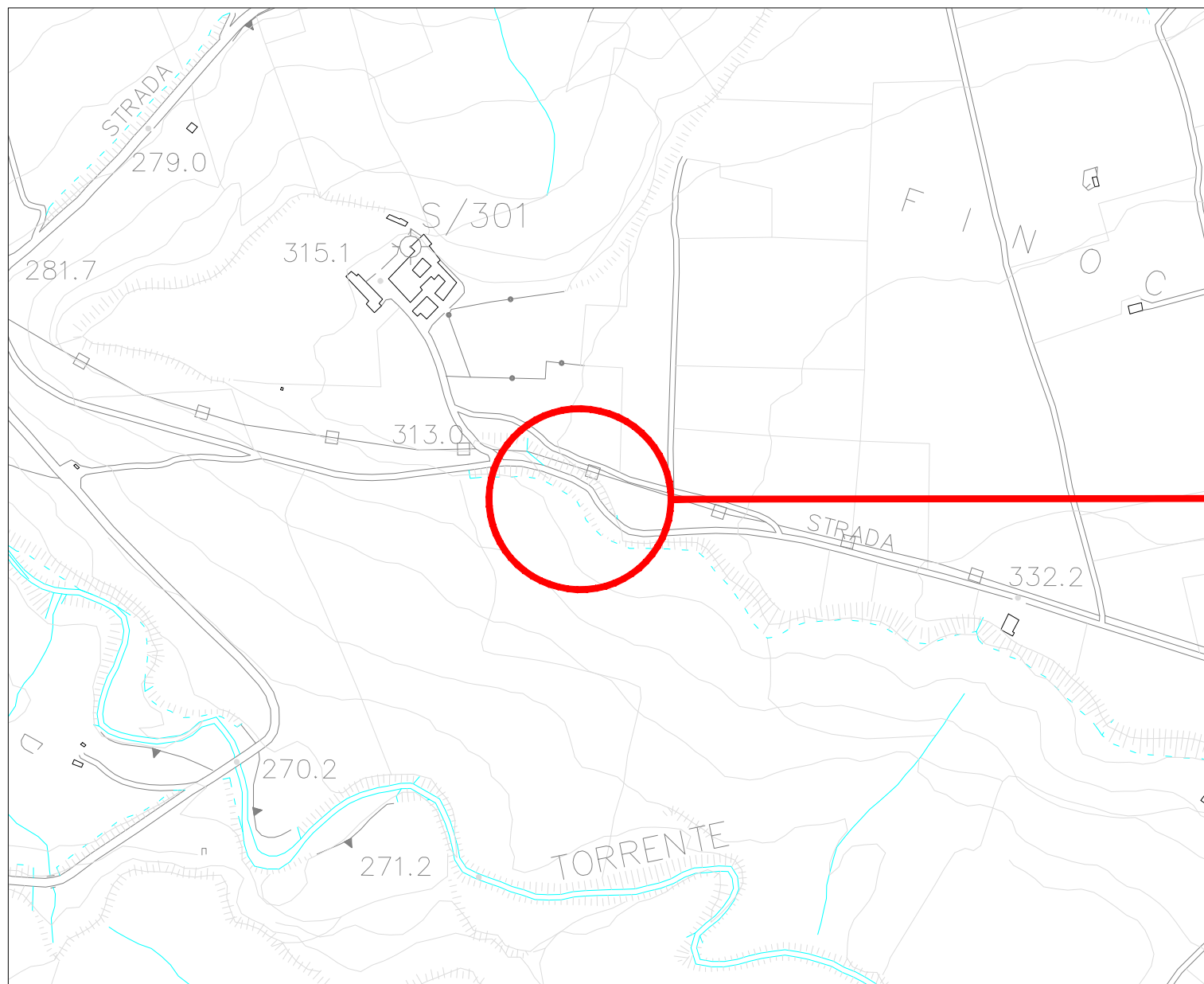

Planimetria catastale - Scala 1:1.000

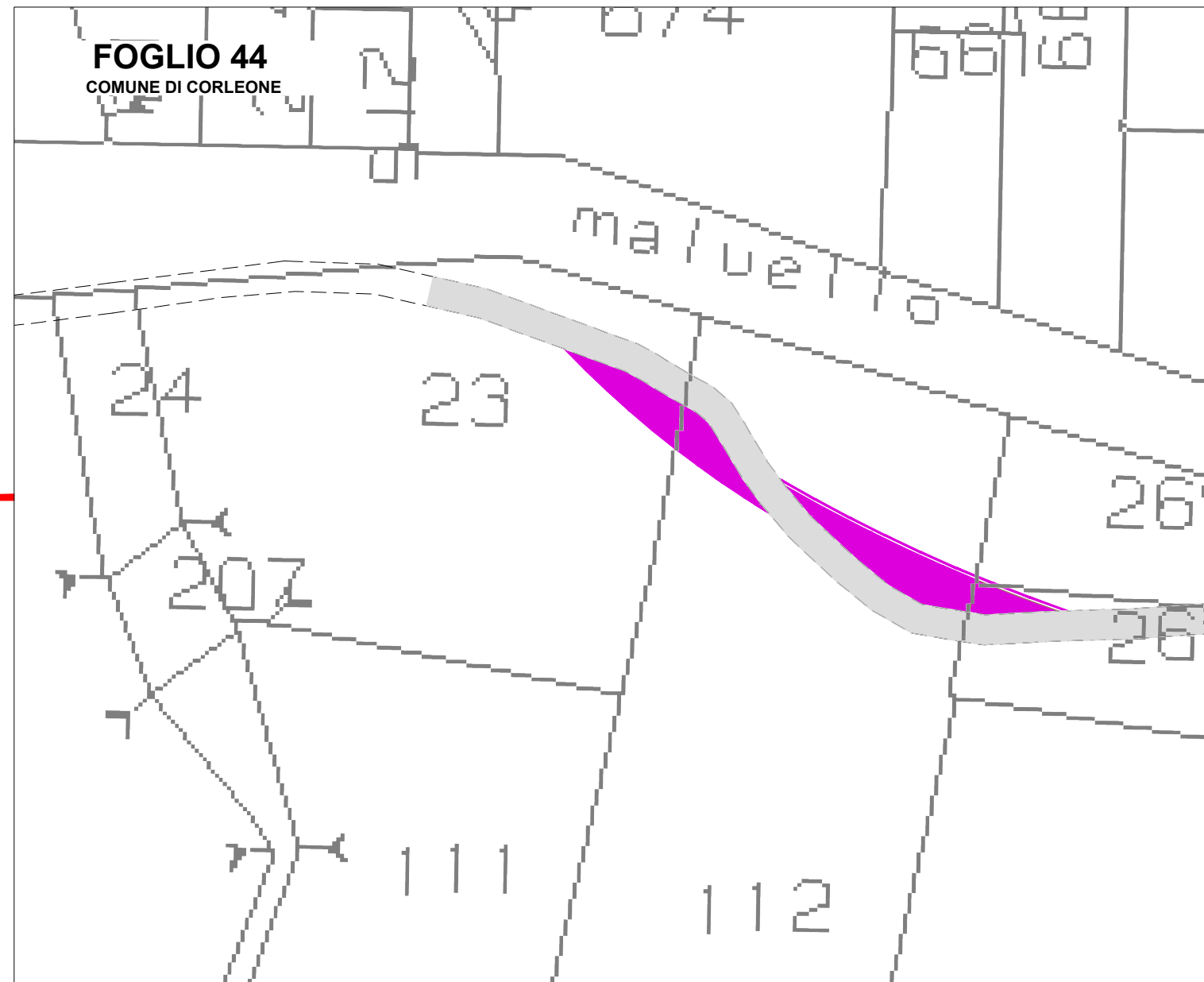

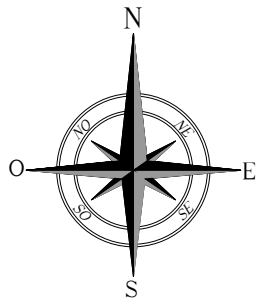

# INTERVENTI DI ADEGAMENTO VIABILITA' ESTERNA DI ACCESSO AL PARCO SU C.T.R. / CATASTALE





INT. 43

Comune di Corleone F.M. 44 p.lle 112, 268, 269

STRADA PROVINCIALE N.97

lat. 37.816516°N long. 13.213356°E

**LEGENDA**

-  VIABILITA' ESISTENTE
-  AREA OCCUPAZIONE REVERSIBILE DI CANTIERE
-  AREA OCCUPAZIONE REVERSIBILE DI ESERCIZIO
-  AREA OCCUPAZIONE IRREVERSIBILE
-  CONFINE COMUNALE

Corografia – Scala 1:5.000

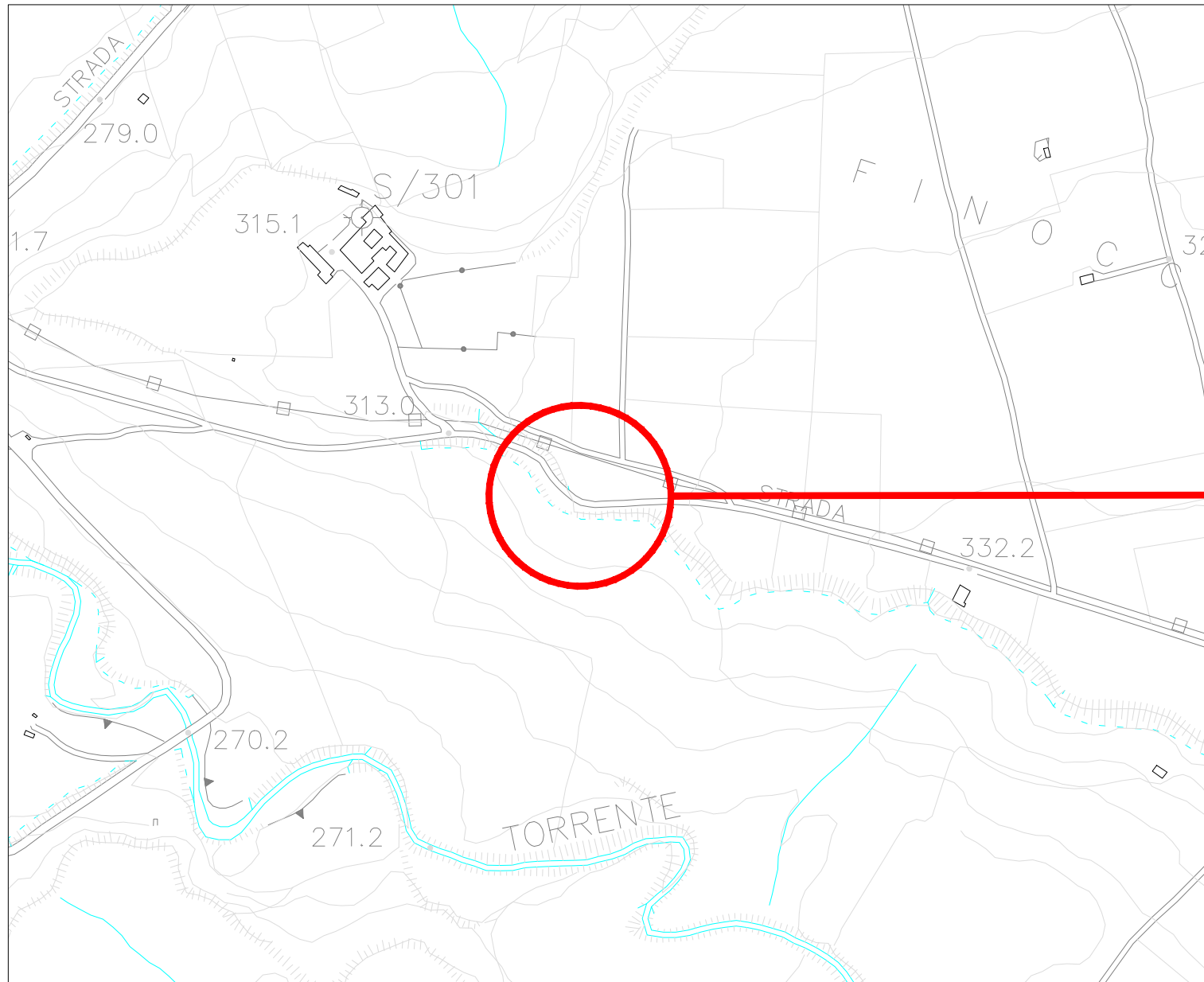

Planimetria catastale - Scala 1:1.000

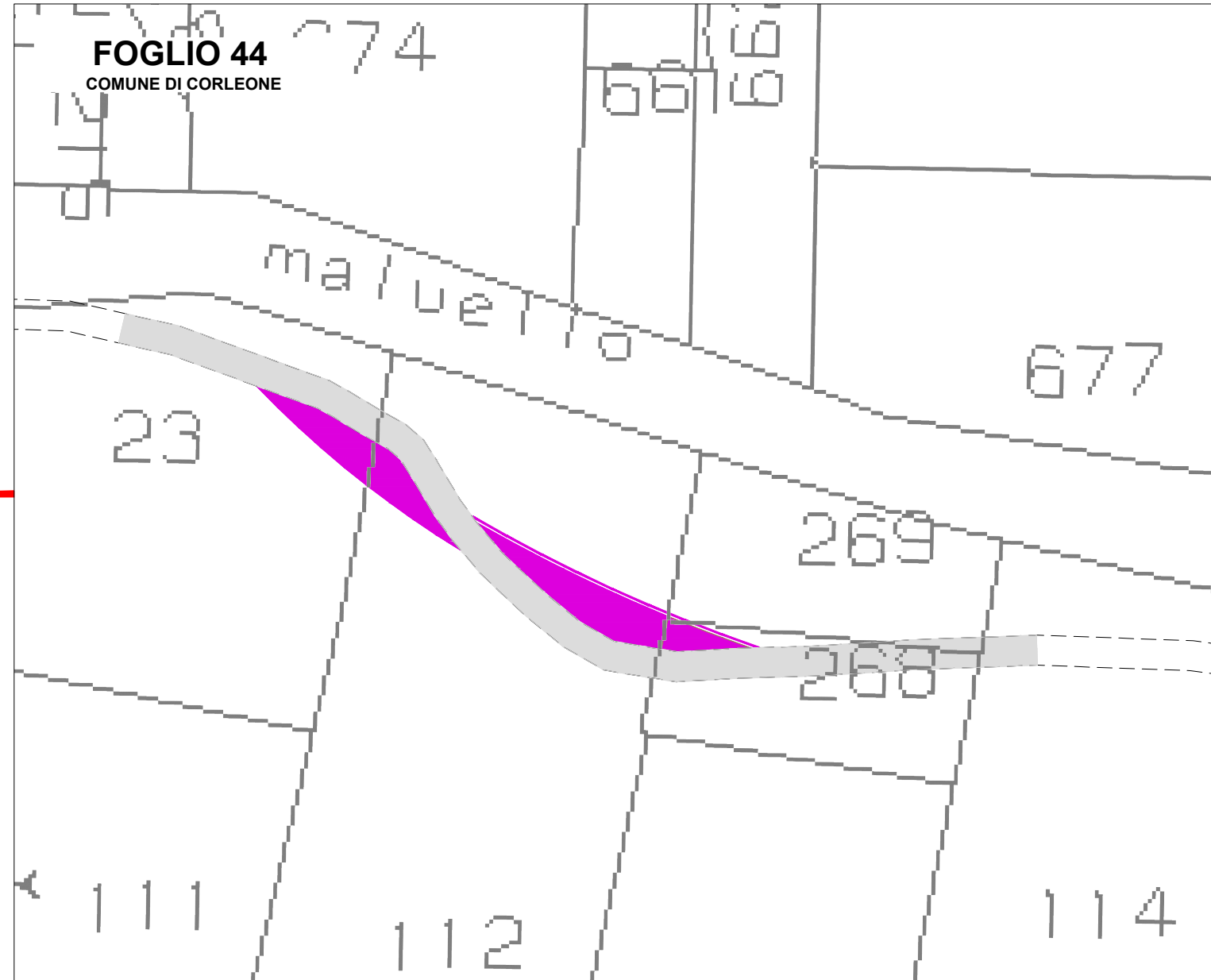

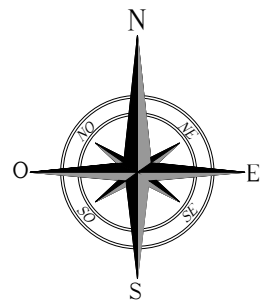

# INTERVENTI DI ADEGAMENTO VIABILITA' ESTERNA DI ACCESSO AL PARCO SU C.T.R. / CATASTALE





INT. 44

Comune di Corleone F.M. 67

STRADA PROVINCIALE N.97

lat. 37.814386°N long. 13.233457°E

## LEGENDA

-  VIABILITA' ESISTENTE
-  AREA OCCUPAZIONE REVERSIBILE DI CANTIERE
-  AREA OCCUPAZIONE REVERSIBILE DI ESERCIZIO
-  AREA OCCUPAZIONE IRREVERSIBILE
-  CONFINE COMUNALE

Corografia – Scala 1:5.000

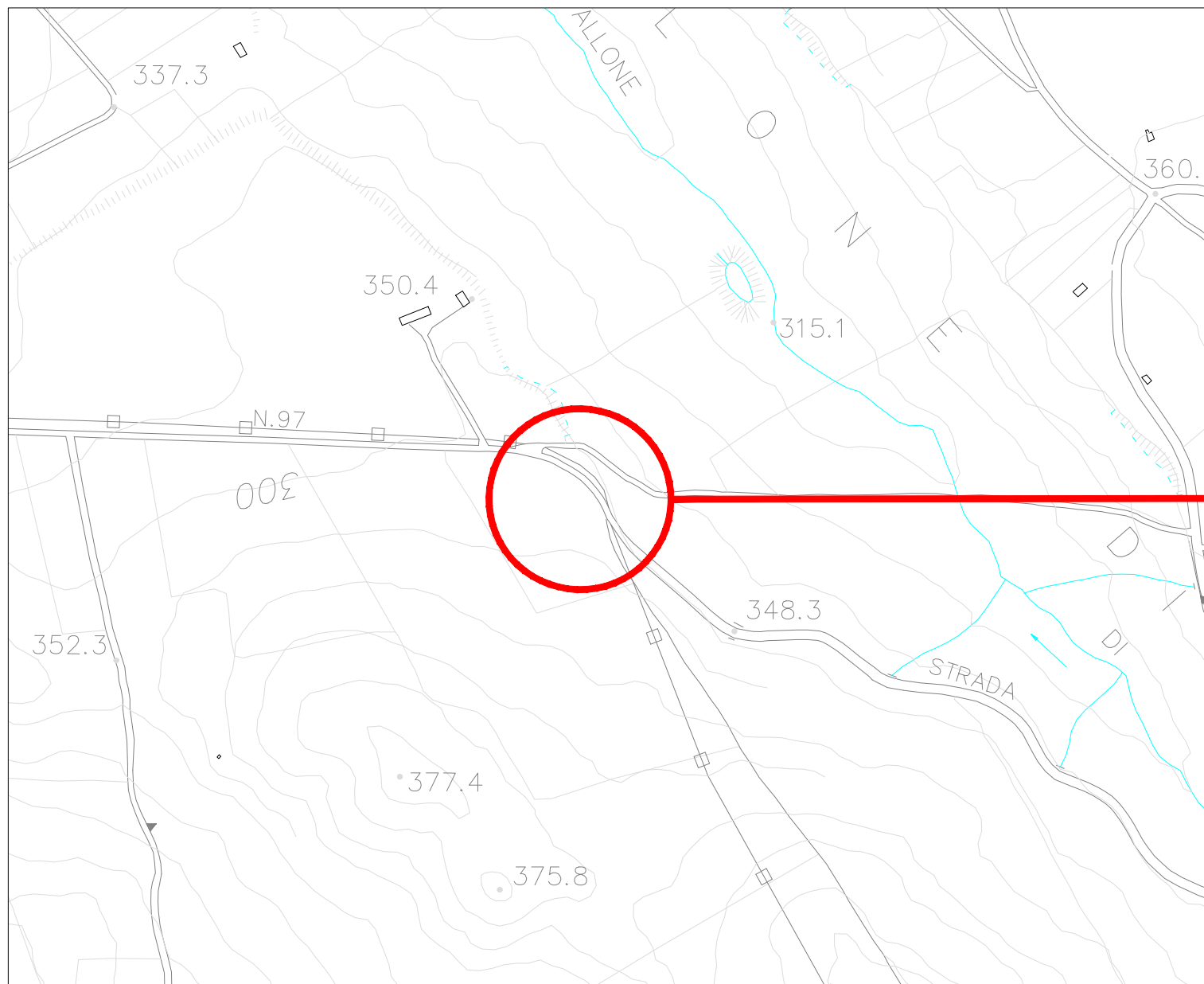

Planimetria catastale - Scala 1:1.000



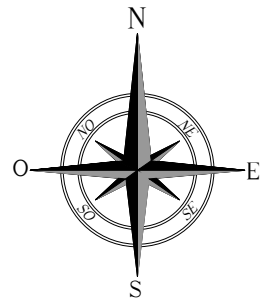

# INTERVENTI DI ADEGAMENTO VIABILITA' ESTERNA DI ACCESSO AL PARCO SU C.T.R. / CATASTALE

INT. 45





Comune di Corleone F.M. 67 p.lle 80, 572

STRADA PROVINCIALE N.97

lat. 37.811706°N

long. 13.240473°E

**LEGENDA**

-  VIABILITA' ESISTENTE
-  AREA OCCUPAZIONE REVERSIBILE DI CANTIERE
-  AREA OCCUPAZIONE REVERSIBILE DI ESERCIZIO
-  AREA OCCUPAZIONE IRREVERSIBILE
-  CONFINE COMUNALE

Corografia – Scala 1:5.000

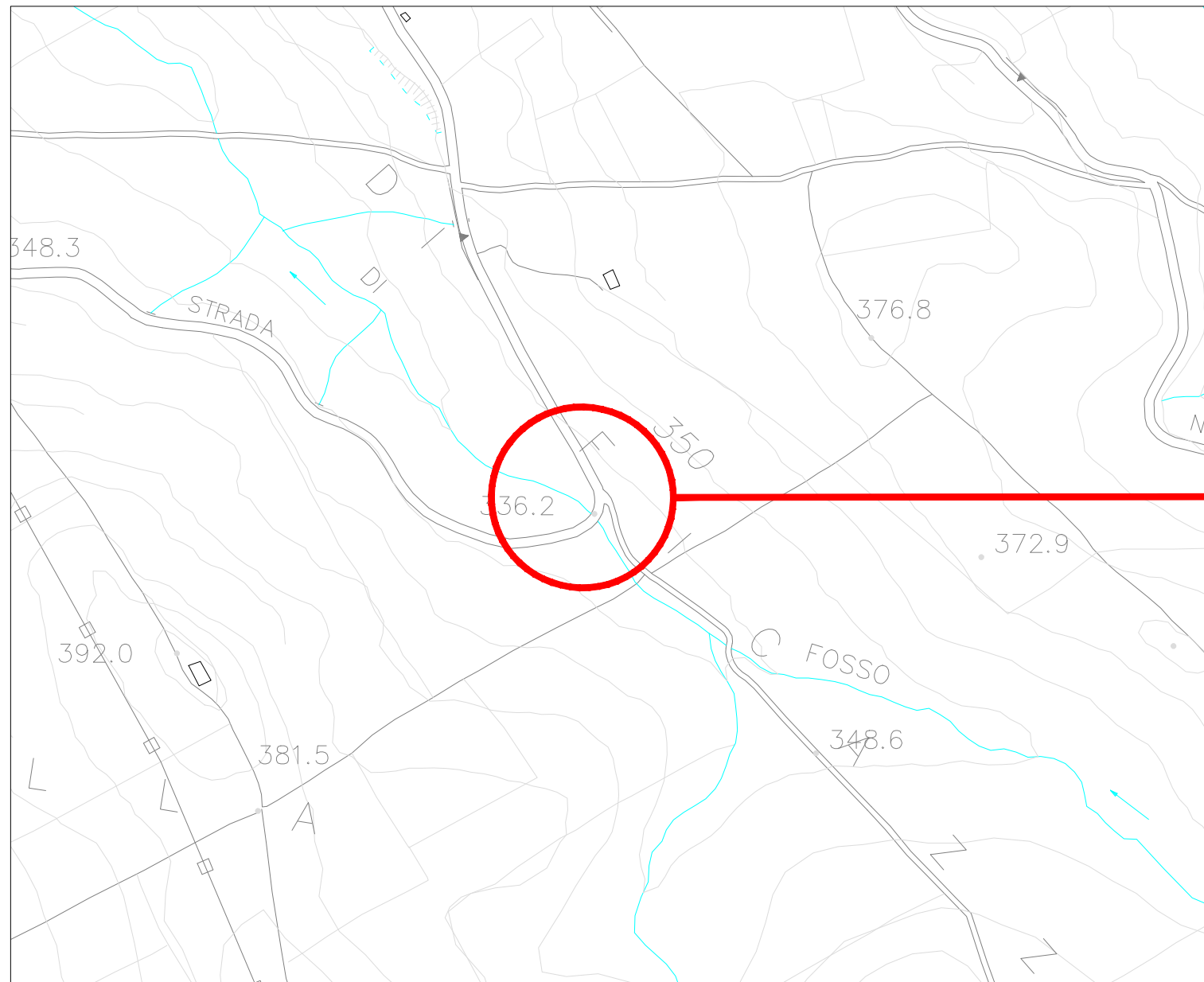

Planimetria catastale - Scala 1:1.000

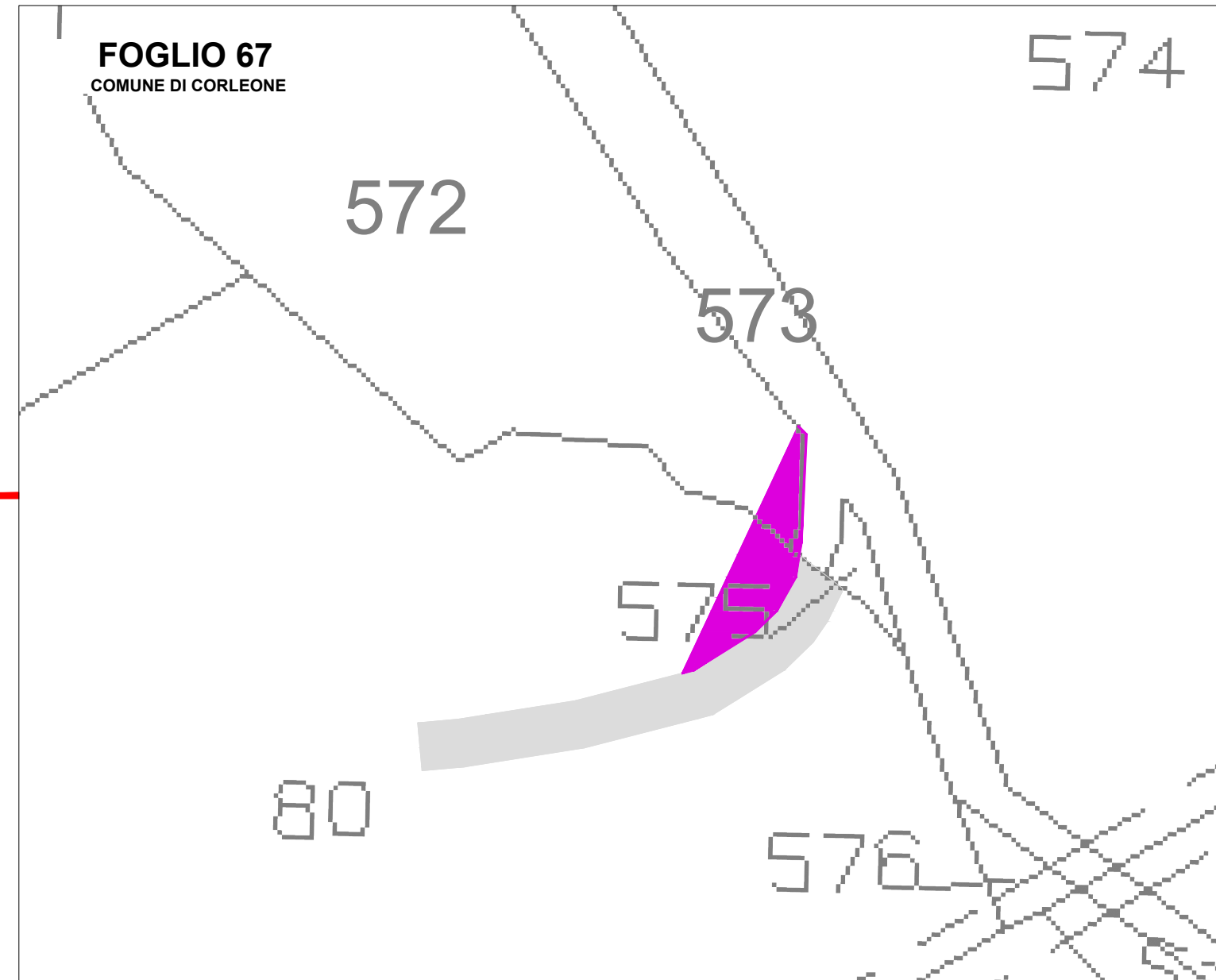

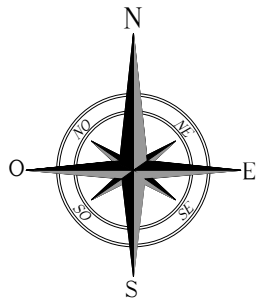

# INTERVENTI DI ADEGAMENTO VIABILITA' ESTERNA DI ACCESSO AL PARCO SU C.T.R. / CATASTALE

INT. 46

Comune di Corleone F.M. 47 p.lle 191, 470

STRADA PROVINCIALE N.97

lat. 37.816691°N long. 13.238719°E

**LEGENDA**

- VIABILITA' ESISTENTE
- AREA OCCUPAZIONE REVERSIBILE DI CANTIERE
- AREA OCCUPAZIONE REVERSIBILE DI ESERCIZIO
- AREA OCCUPAZIONE IRREVERSIBILE
- CONFINE COMUNALE

Corografia – Scala 1:5.000

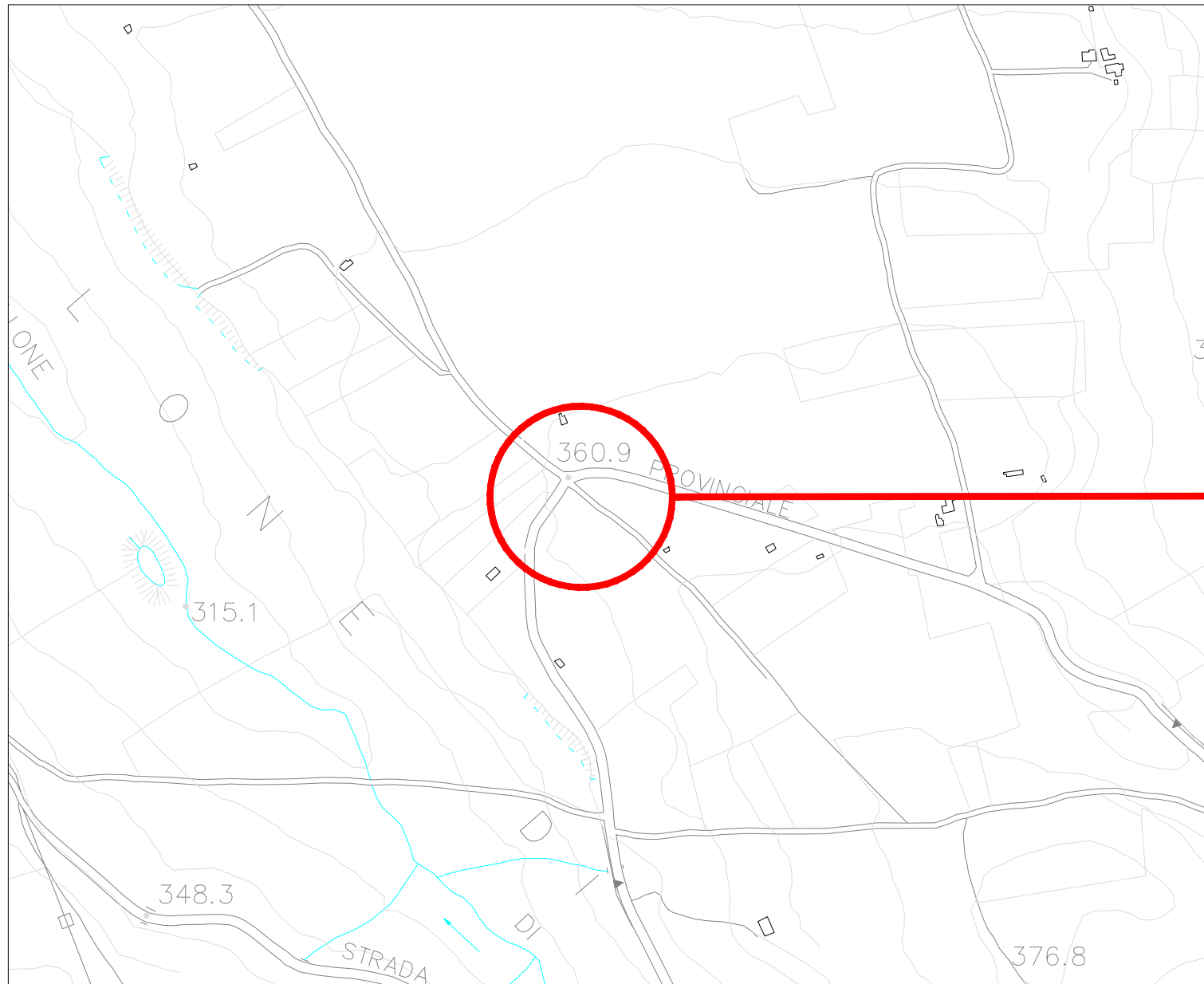

Planimetria catastale - Scala 1:1.000

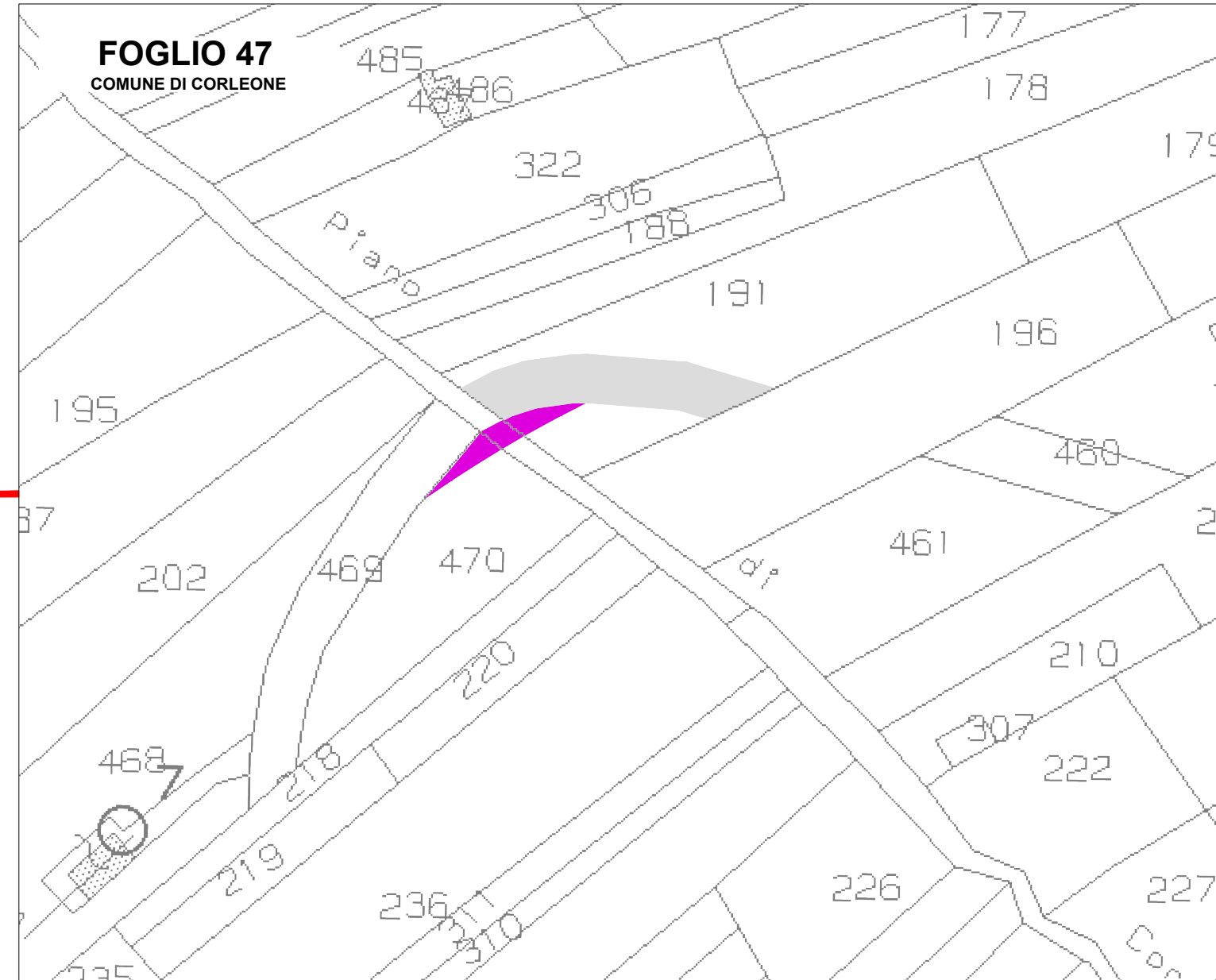

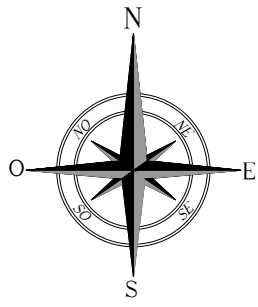

# INTERVENTI DI ADEGAMENTO VIABILITA' ESTERNA DI ACCESSO AL PARCO SU C.T.R. / CATASTALE





INT. 47

Comune di Corleone F.M. 47 p.lla 353 F.M. 68

STRADA PROVINCIALE N.97

lat. 37.814216°N long. 13.245639°E

**LEGENDA**

-  VIABILITA' ESISTENTE
-  AREA OCCUPAZIONE REVERSIBILE DI CANTIERE
-  AREA OCCUPAZIONE REVERSIBILE DI ESERCIZIO
-  AREA OCCUPAZIONE IRREVERSIBILE
-  CONFINE COMUNALE

Corografia – Scala 1:5.000

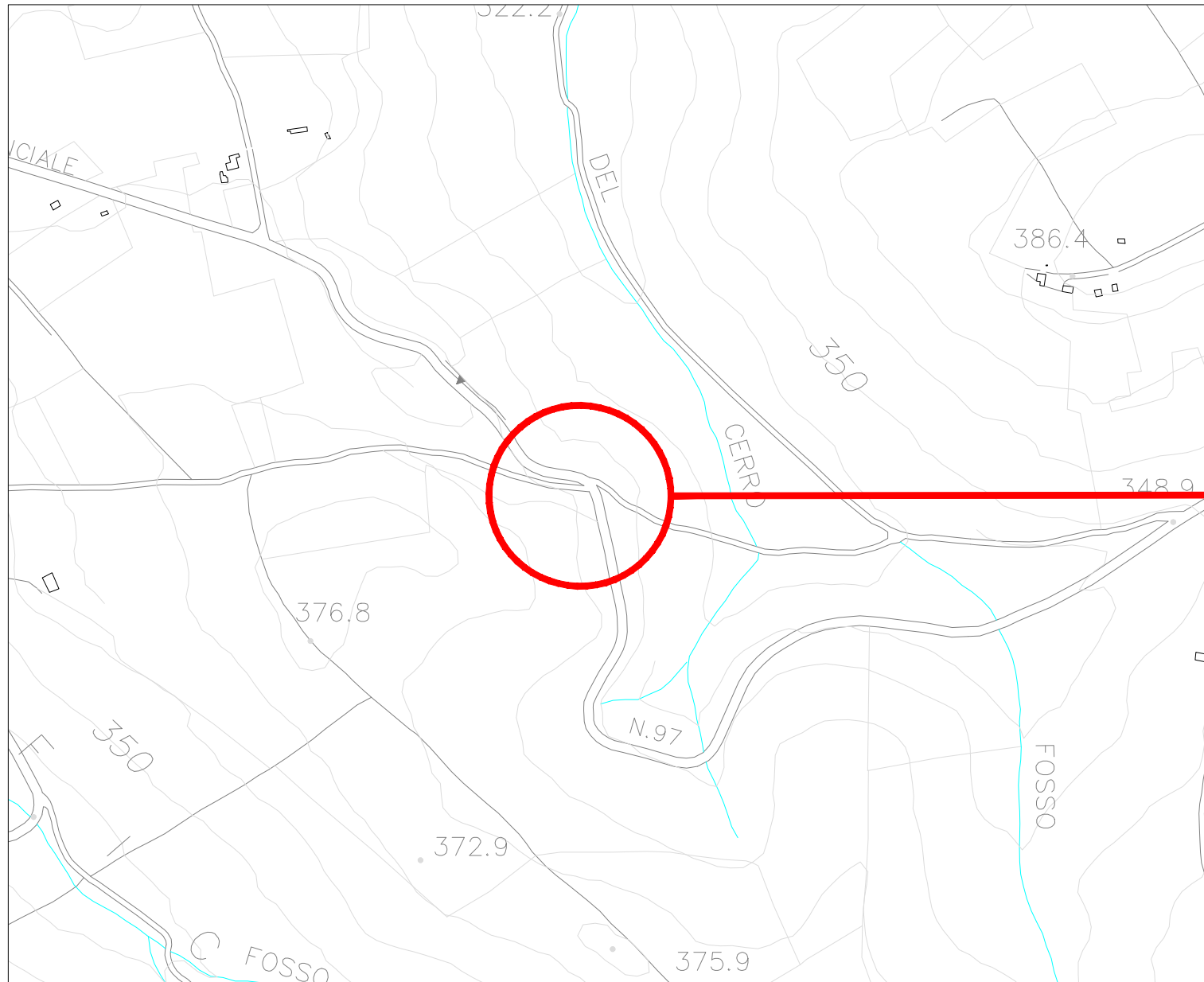

Planimetria catastale - Scala 1:1.000

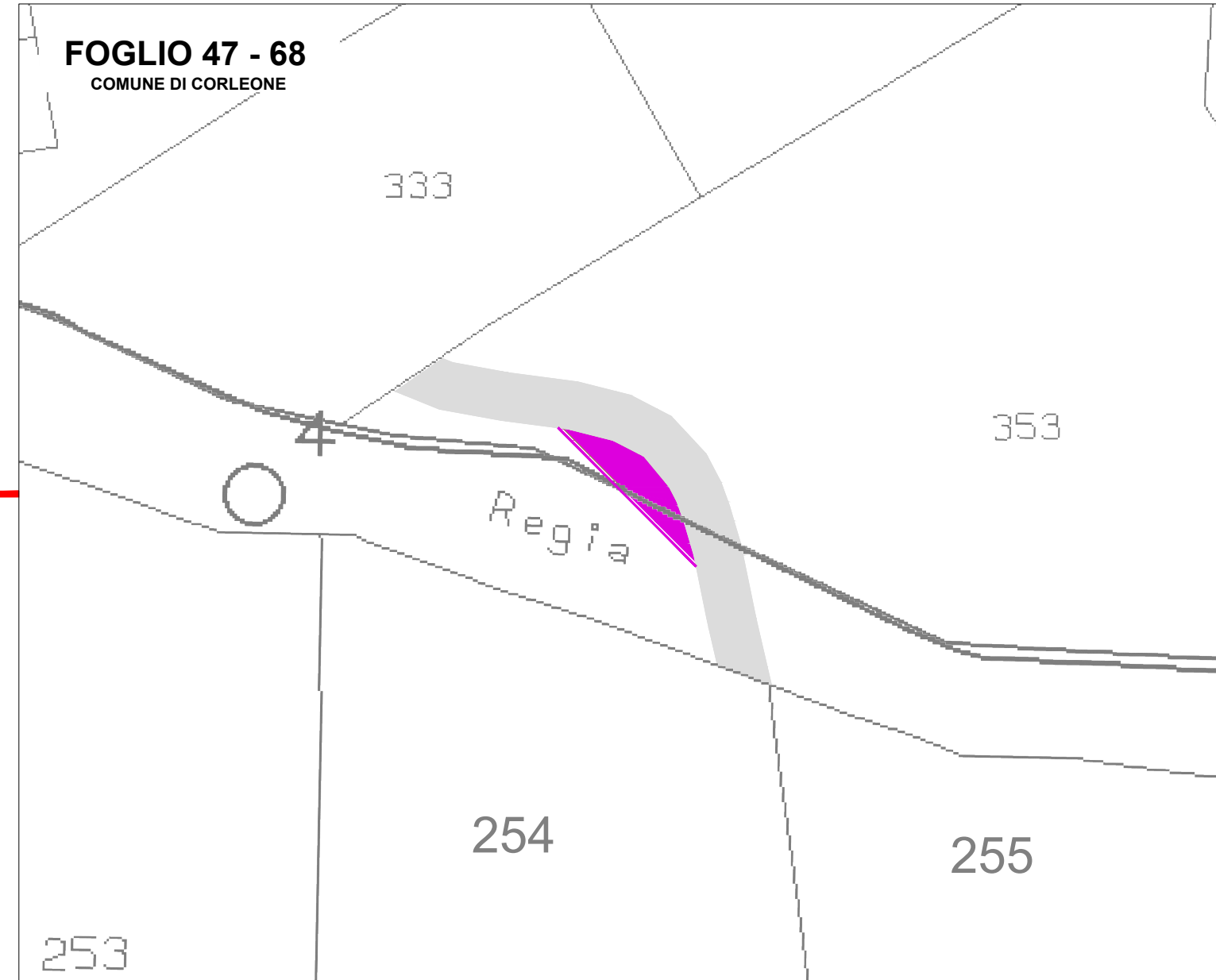

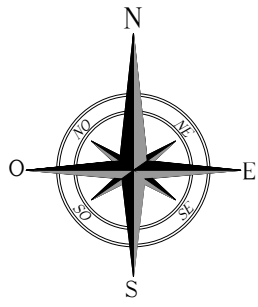

# INTERVENTI DI ADEGAMENTO VIABILITA' ESTERNA DI ACCESSO AL PARCO SU C.T.R. / CATASTALE





INT. 48

Comune di Corleone F.M. 68 p.lle 254, 259, 329

STRADA PROVINCIALE N.97

lat. 37.812461°N long. 13.245783°E

**LEGENDA**

-  VIABILITA' ESISTENTE
-  AREA OCCUPAZIONE REVERSIBILE DI CANTIERE
-  AREA OCCUPAZIONE REVERSIBILE DI ESERCIZIO
-  AREA OCCUPAZIONE IRREVERSIBILE
-  CONFINE COMUNALE

Corografia – Scala 1:5.000

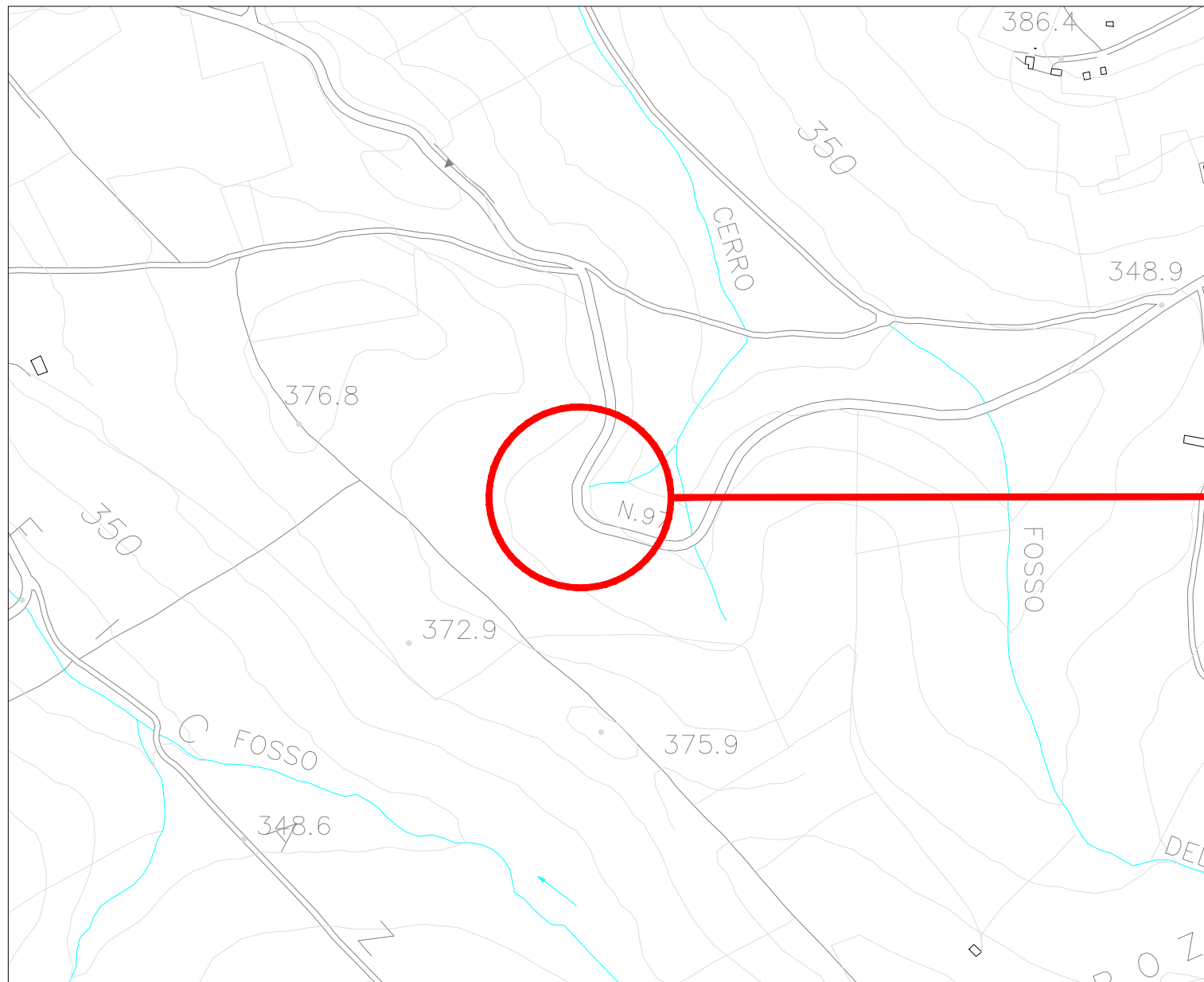

Planimetria catastale - Scala 1:1.000

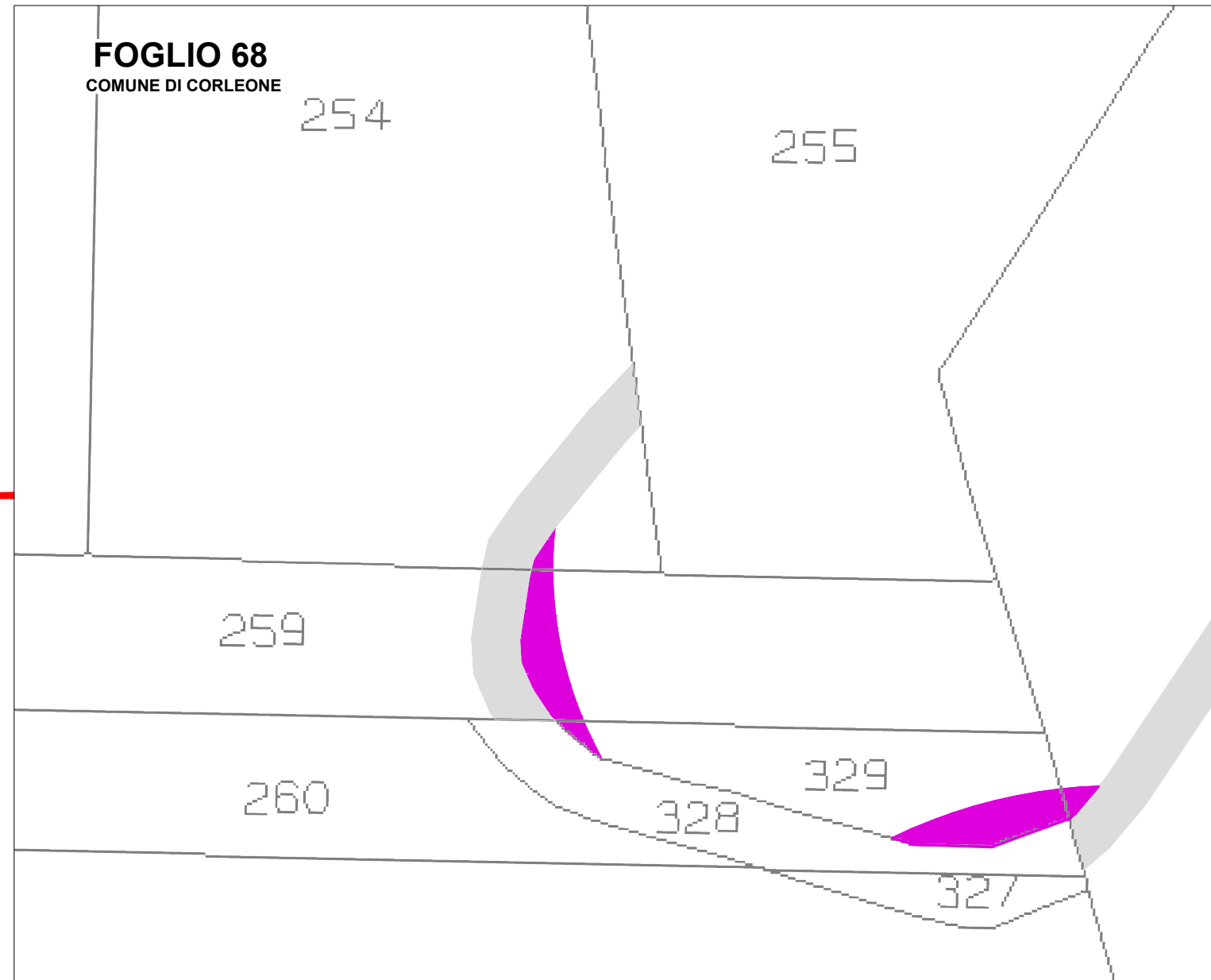



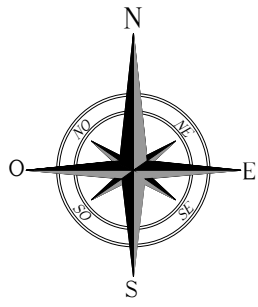

# INTERVENTI DI ADEGAMENTO VIABILITA' ESTERNA DI ACCESSO AL PARCO SU C.T.R. / CATASTALE





INT. 49

Comune di Corleone F.M. 68 p.lle 256, 329

STRADA PROVINCIALE N.97

lat. 37.812269°N long. 13.246799°E

**LEGENDA**

-  VIABILITA' ESISTENTE
-  AREA OCCUPAZIONE REVERSIBILE DI CANTIERE
-  AREA OCCUPAZIONE REVERSIBILE DI ESERCIZIO
-  AREA OCCUPAZIONE IRREVERSIBILE
-  CONFINE COMUNALE

Corografia – Scala 1:5.000

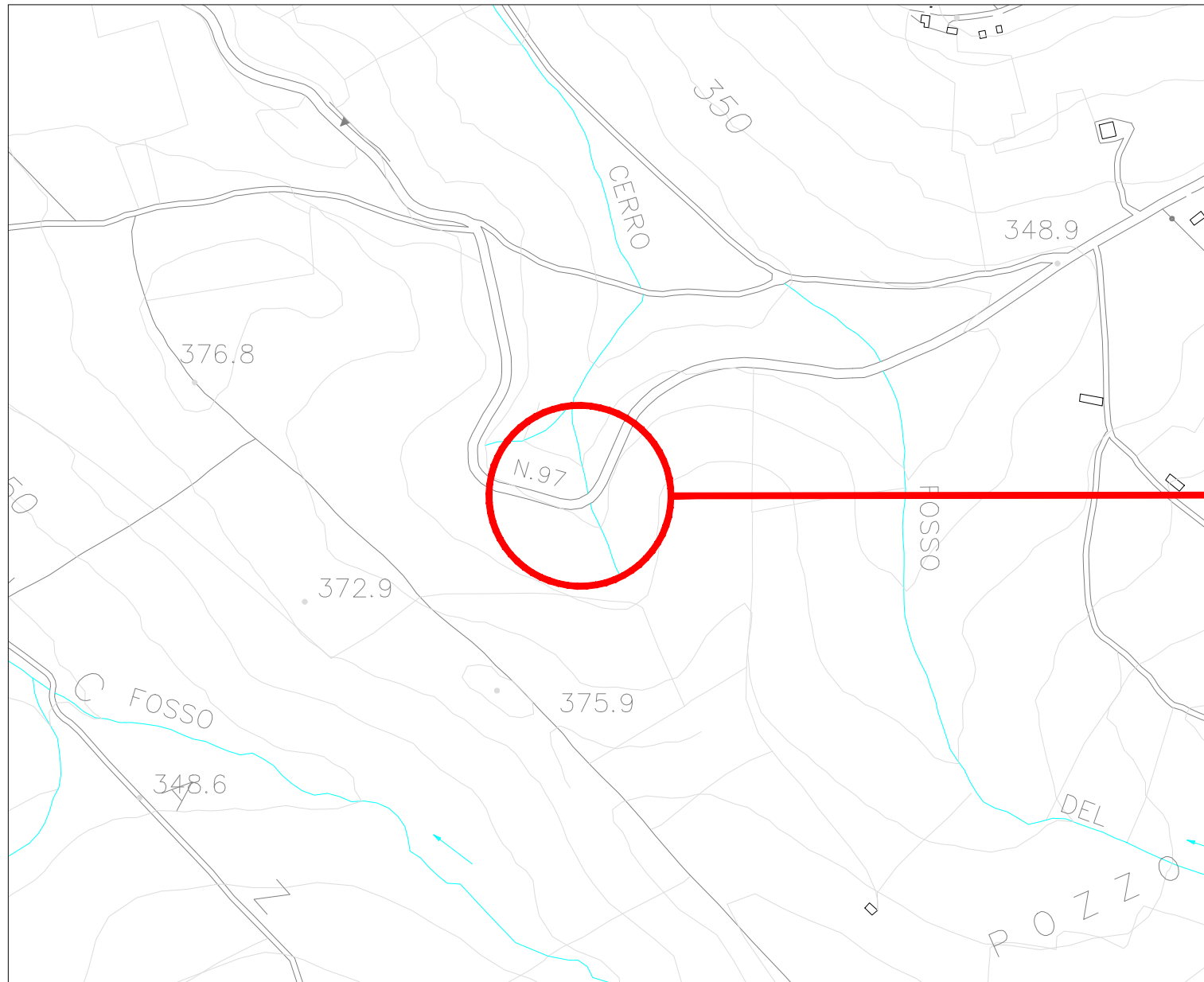

Planimetria catastale - Scala 1:1.000

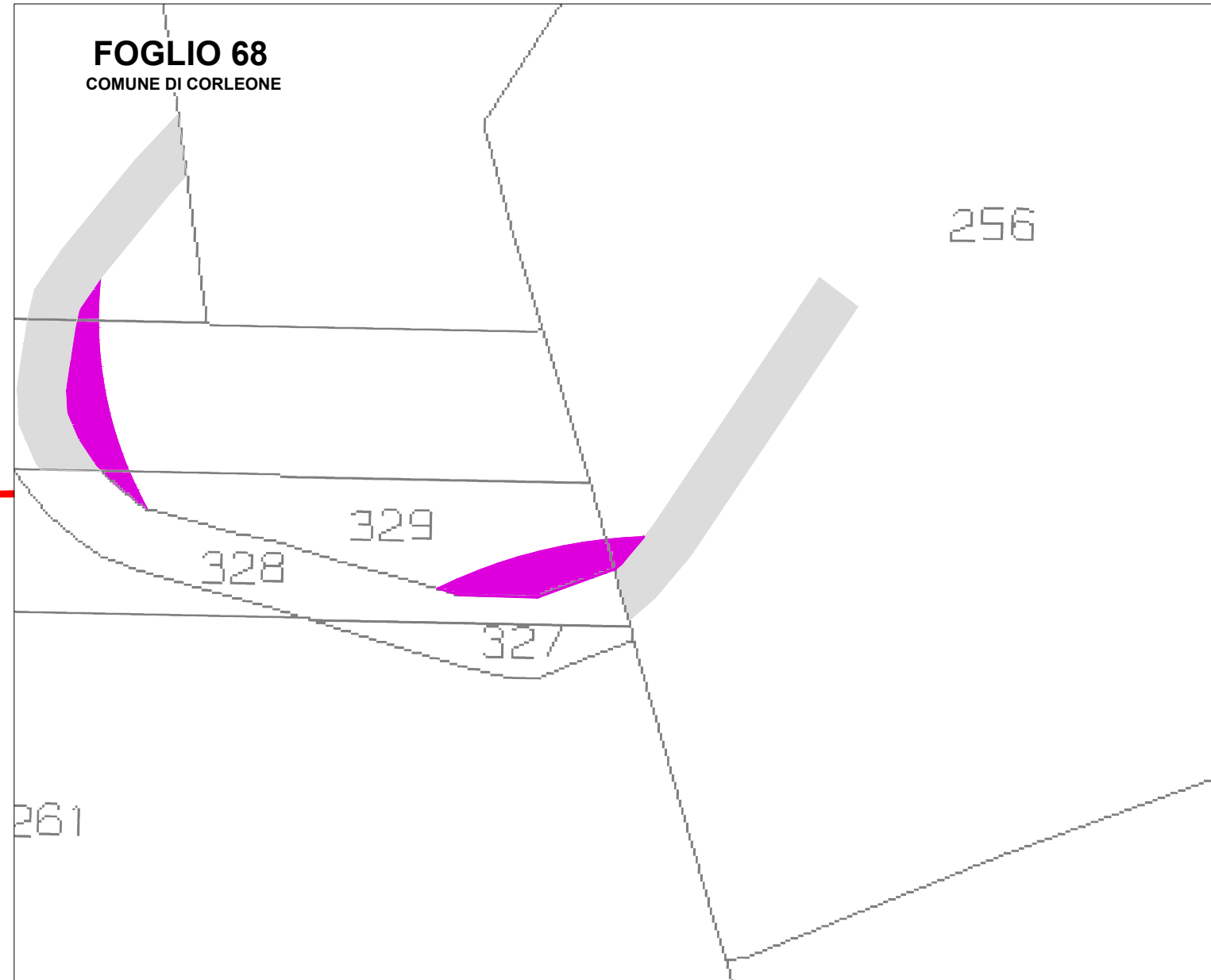

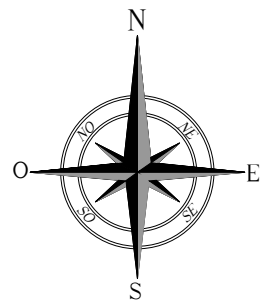

# INTERVENTI DI ADEGAMENTO VIABILITA' ESTERNA DI ACCESSO AL PARCO SU C.T.R. / CATASTALE





INT. 50

Comune di Corleone F.M. 69 p.lle 414, 438, 439, 440, 441, 517

incrocio tra STRADA PROVINCIALE N.97 e STRADA CONSORZIALE allacciante Manganelli

lat. 37.811970°N long. 13.265472°E

**LEGENDA**

-  VIABILITA' ESISTENTE
-  AREA OCCUPAZIONE REVERSIBILE DI CANTIERE
-  AREA OCCUPAZIONE REVERSIBILE DI ESERCIZIO
-  AREA OCCUPAZIONE IRREVERSIBILE
-  CONFINE COMUNALE

Corografia – Scala 1:5.000

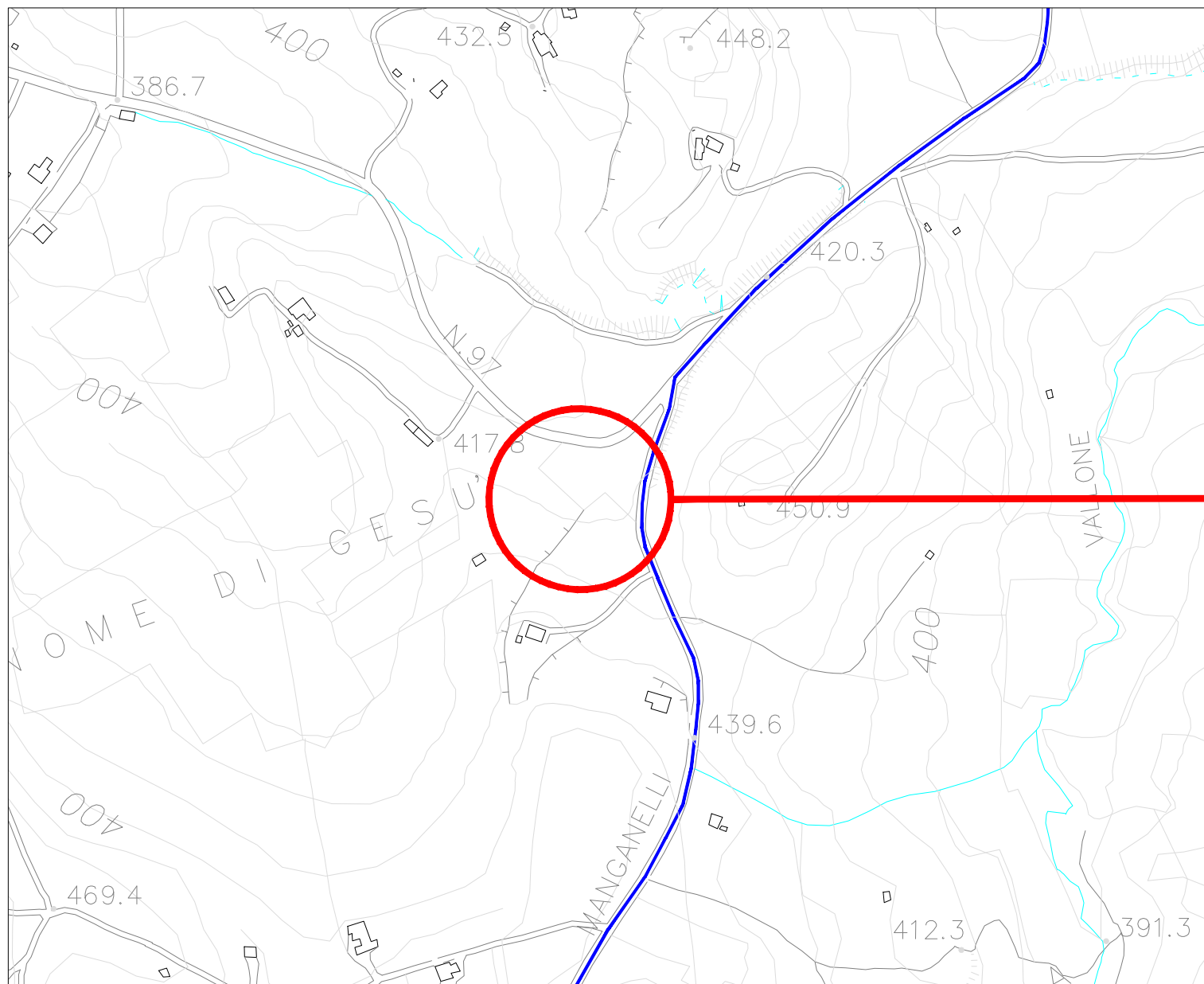

Planimetria catastale - Scala 1:1.000

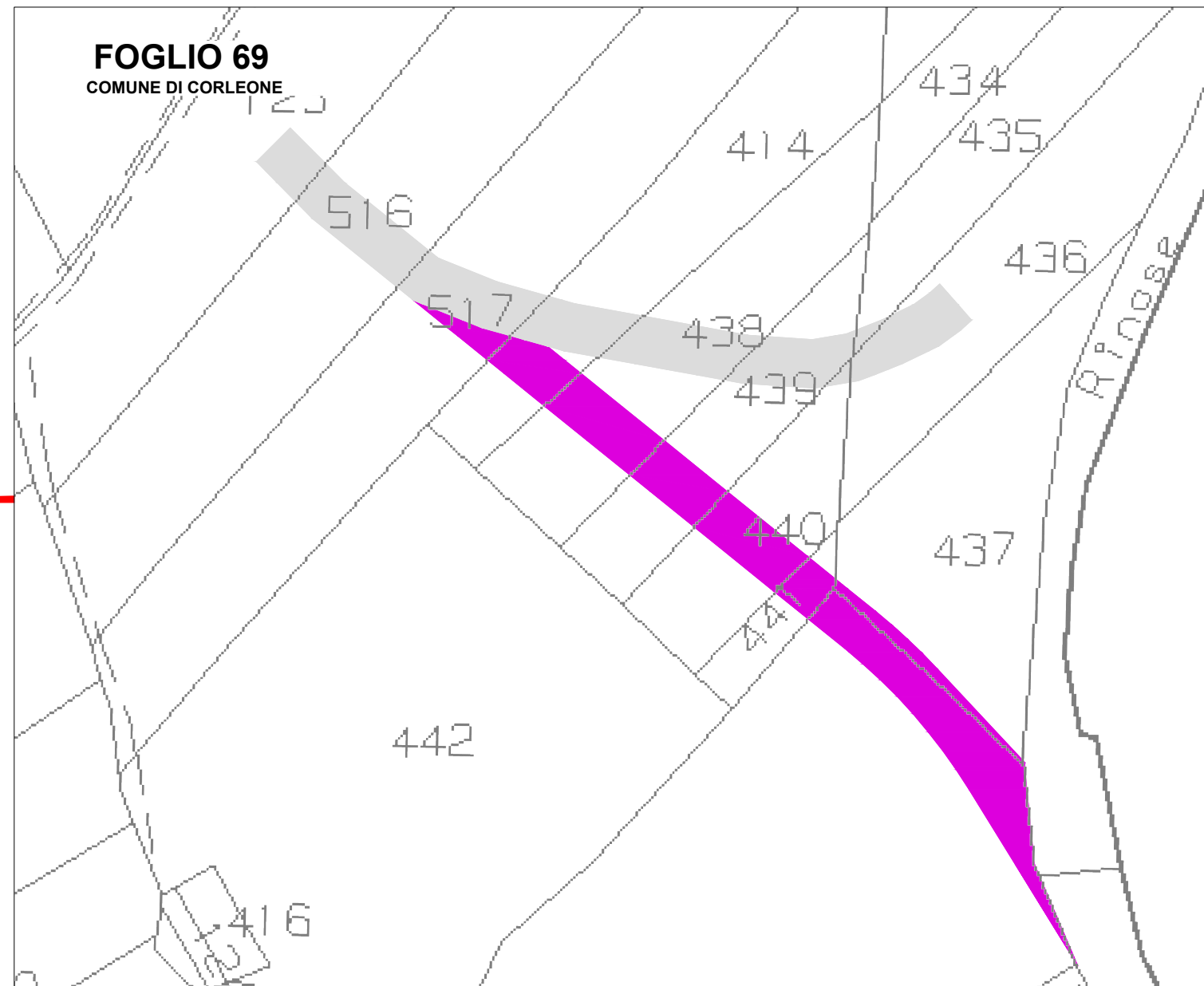

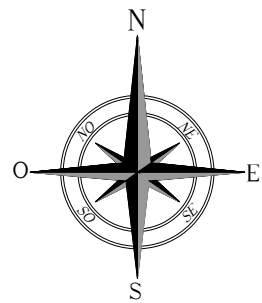

# INTERVENTI DI ADEGAMENTO VIABILITA' ESTERNA DI ACCESSO AL PARCO SU C.T.R. / CATASTALE

INT. 51

Comune di Corleone F.M. 70 p.lle 631, 644, 645

STRADA CONSORZIALE allacciante Manganelli

lat. 37.801253°N long. 13.258144°E

**LEGENDA**

- VIABILITA' ESISTENTE
- AREA OCCUPAZIONE REVERSIBILE DI CANTIERE
- AREA OCCUPAZIONE REVERSIBILE DI ESERCIZIO
- AREA OCCUPAZIONE IRREVERSIBILE
- CONFINE COMUNALE

Corografia – Scala 1:5.000

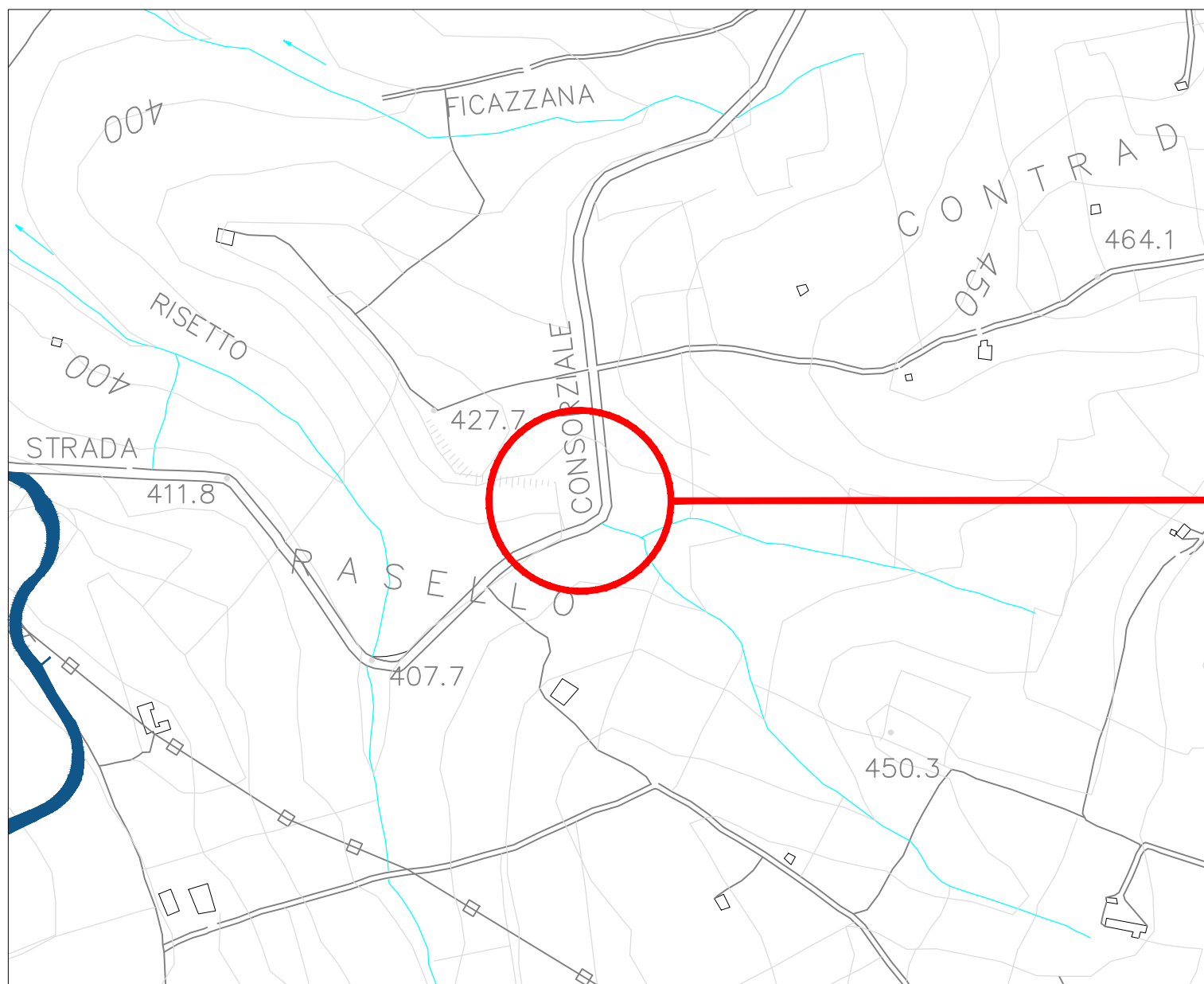

Planimetria catastale - Scala 1:1.000

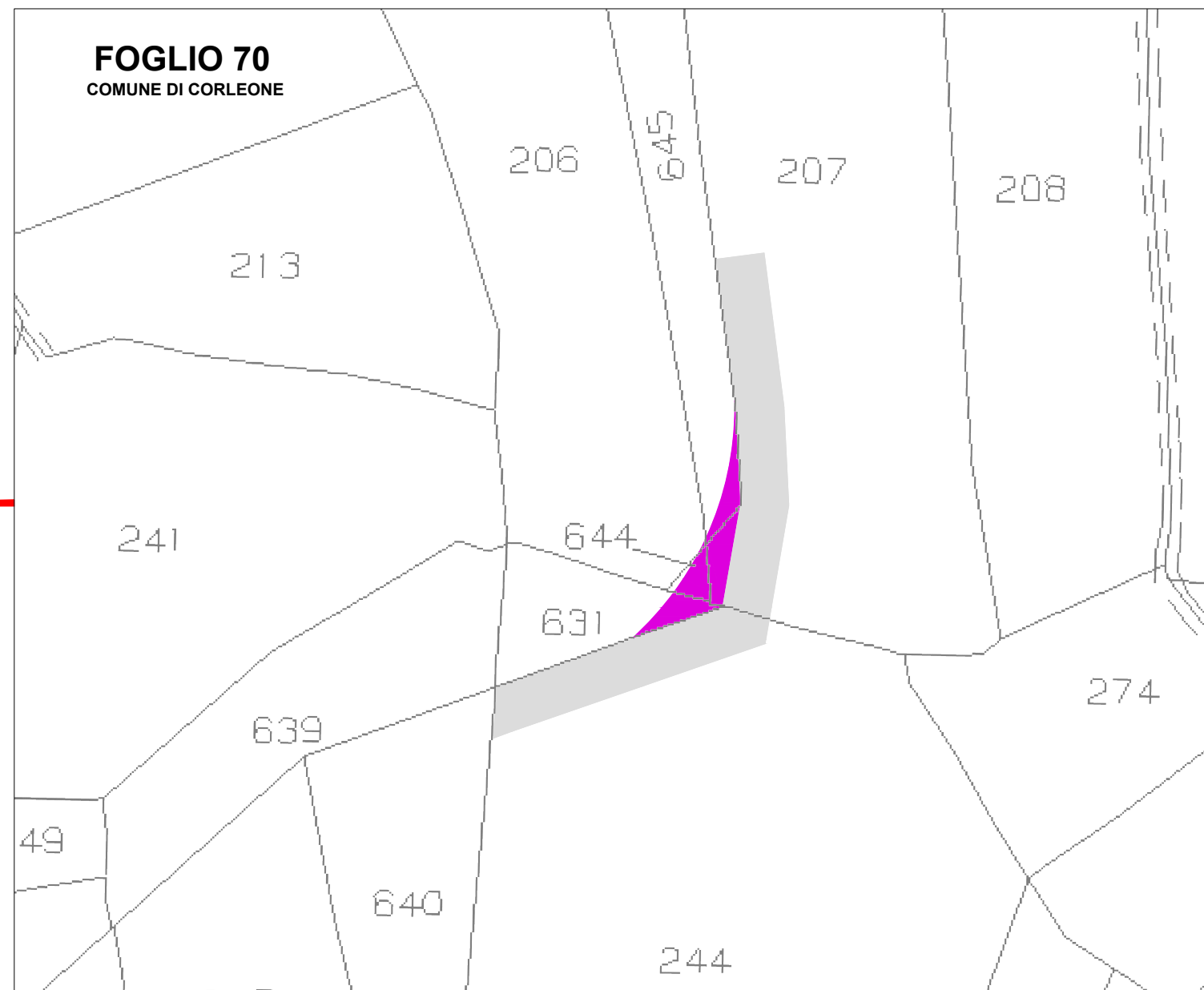

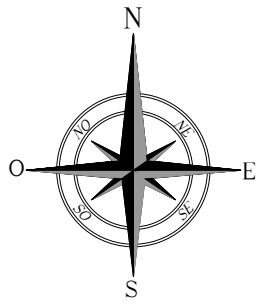

# INTERVENTI DI ADEGAMENTO VIABILITA' ESTERNA DI ACCESSO AL PARCO SU C.T.R. / CATASTALE





INT. 52

Comune di Corleone F.M. 70 p.lla 632 F.M. 88 p.lla 33

STRADA CONSORZIALE allacciante Manganelli

lat. 37.800134°N long. 13.256195°E

**LEGENDA**

-  VIABILITA' ESISTENTE
-  AREA OCCUPAZIONE REVERSIBILE DI CANTIERE
-  AREA OCCUPAZIONE REVERSIBILE DI ESERCIZIO
-  AREA OCCUPAZIONE IRREVERSIBILE
-  CONFINE COMUNALE

Corografia – Scala 1:5.000

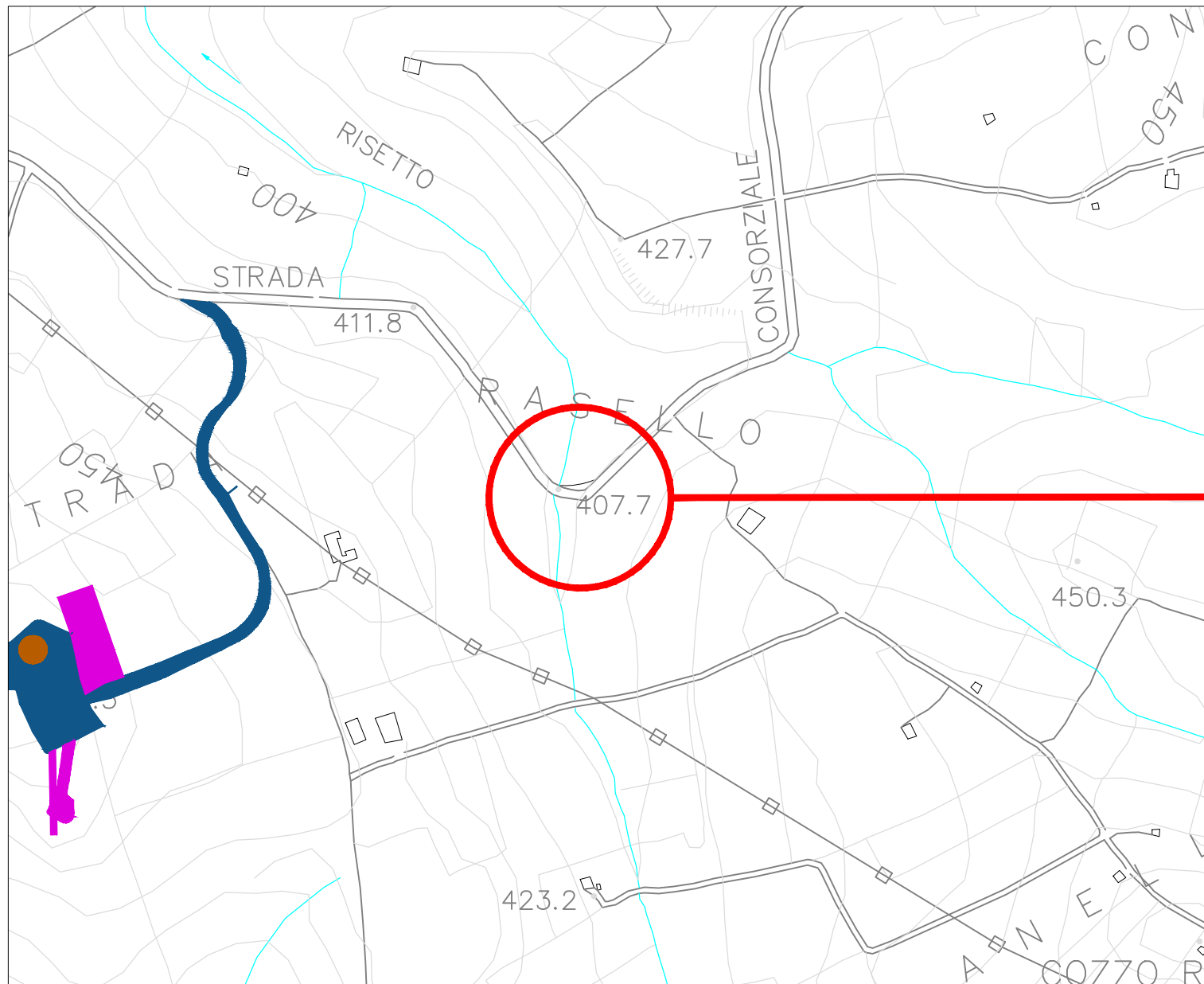

Planimetria catastale - Scala 1:1.000

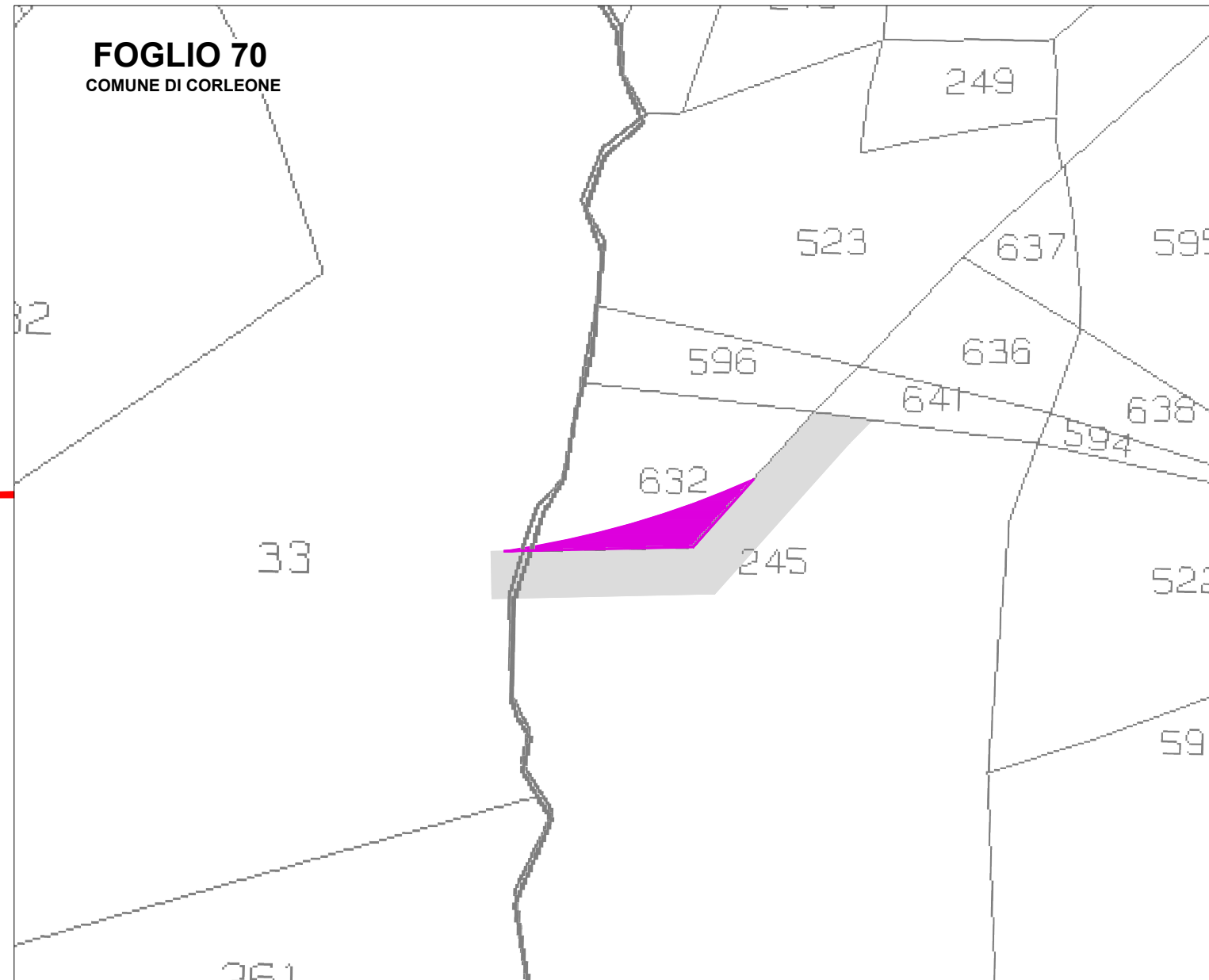

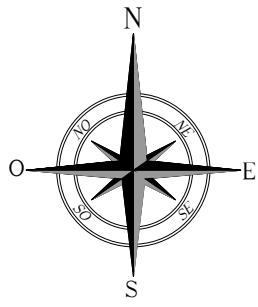

# INTERVENTI DI ADEGAMENTO VIABILITA' ESTERNA DI ACCESSO AL PARCO SU C.T.R. / CATASTALE





INT. 53

Comune di Corleone F.M. 88 p.lla 459, 462

STRADA CONSORZIALE allacciante Manganelli

lat. 37.801418°N long. 13.254822°E

**LEGENDA**

-  VIABILITA' ESISTENTE
-  AREA OCCUPAZIONE REVERSIBILE DI CANTIERE
-  AREA OCCUPAZIONE REVERSIBILE DI ESERCIZIO
-  AREA OCCUPAZIONE IRREVERSIBILE
-  CONFINE COMUNALE

Corografia – Scala 1:5.000

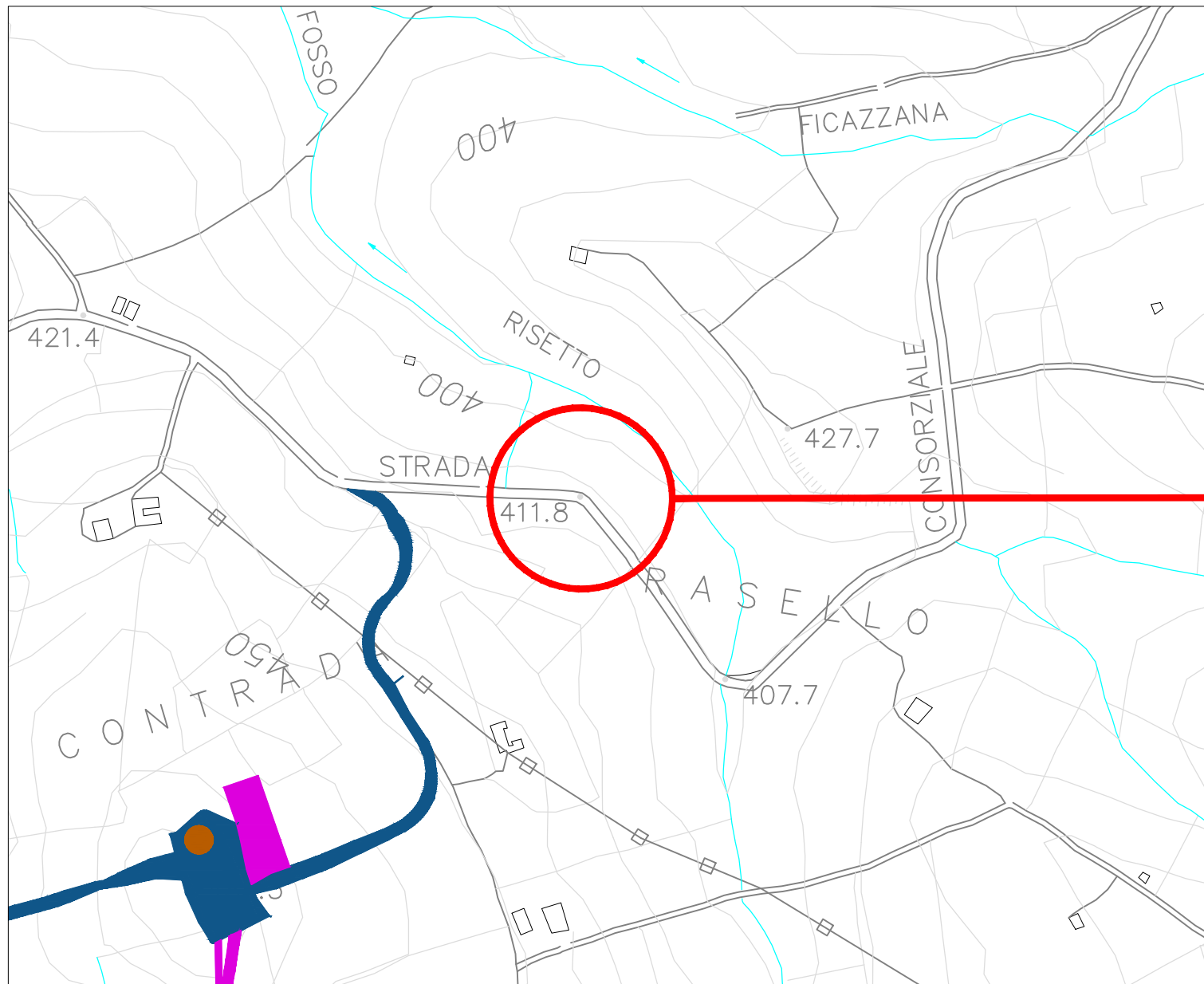

Planimetria catastale - Scala 1:1.000

