

P-SN8 PROGETTO
SEZIONI TRASVERSALI Tratto 3 - Tav 3/6
SCALA 1:200

NOTE GENERALI

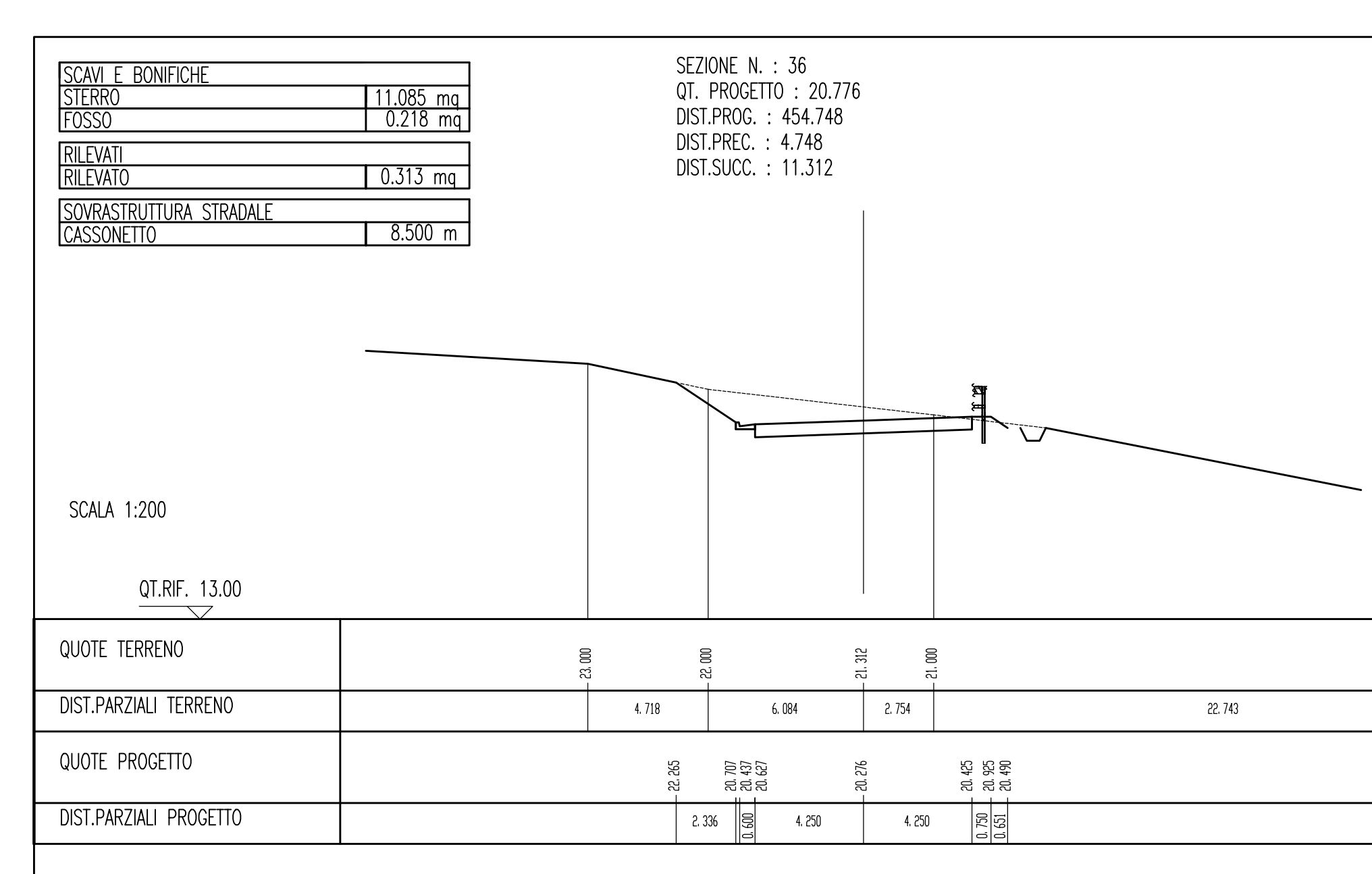
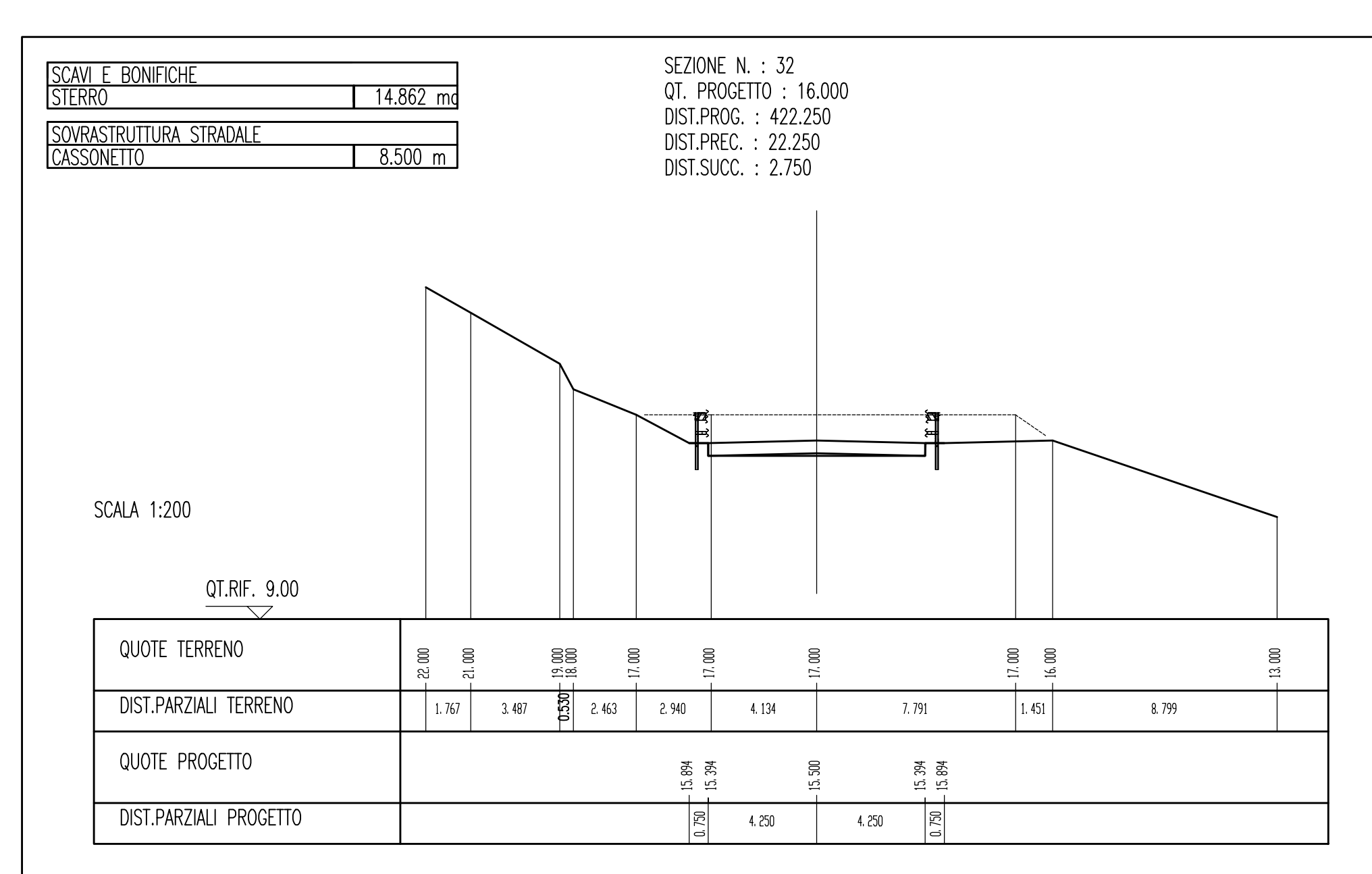
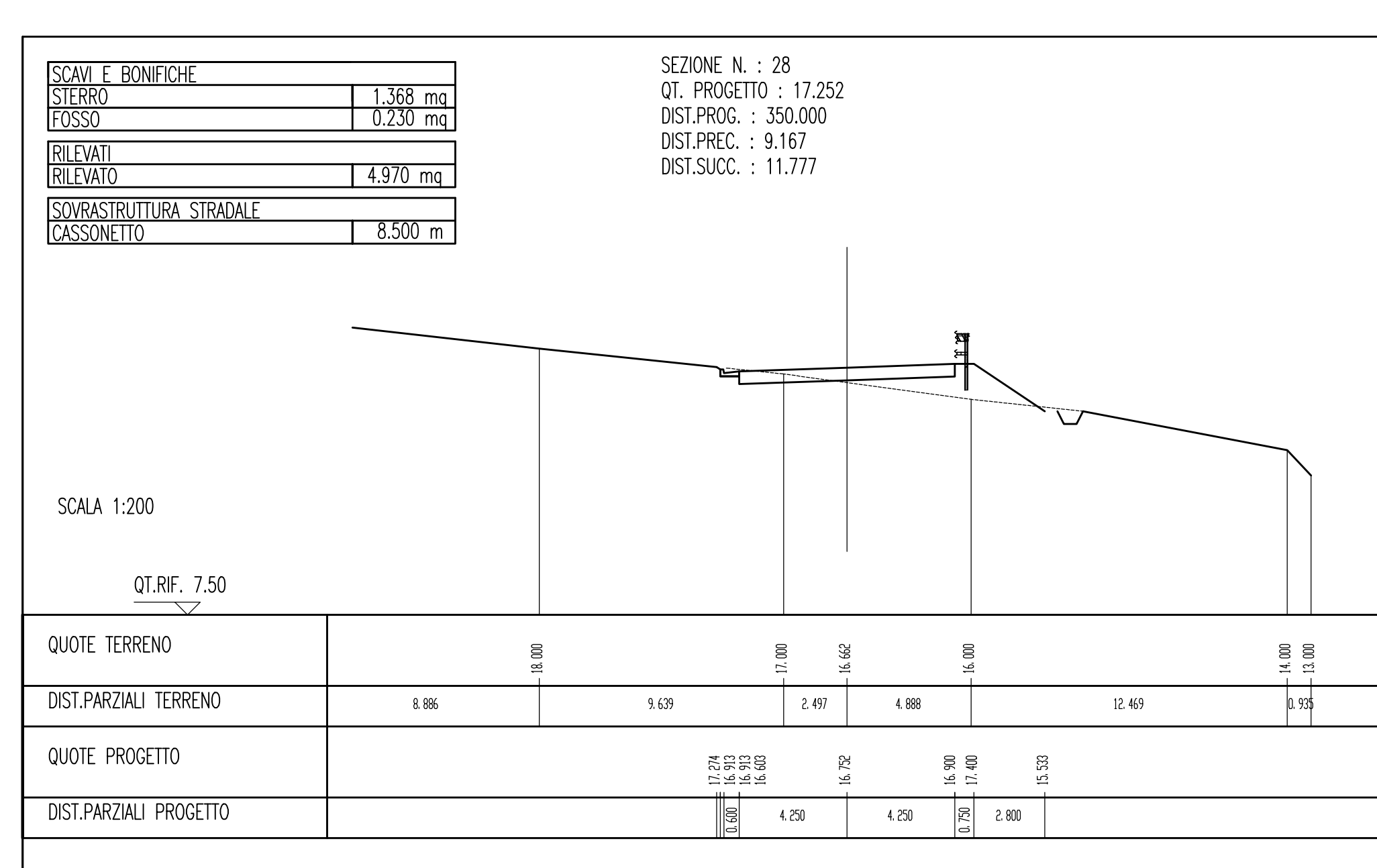
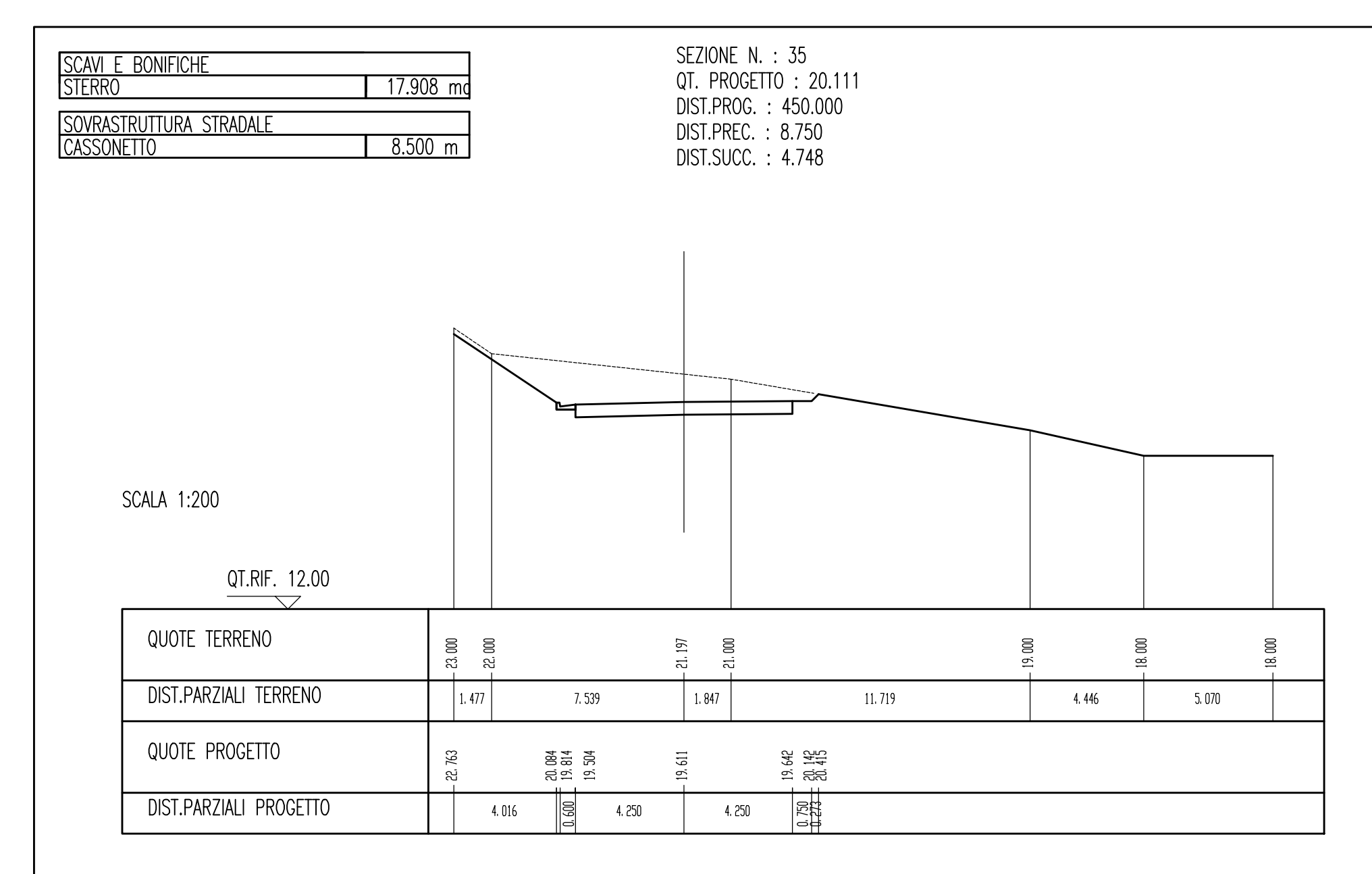
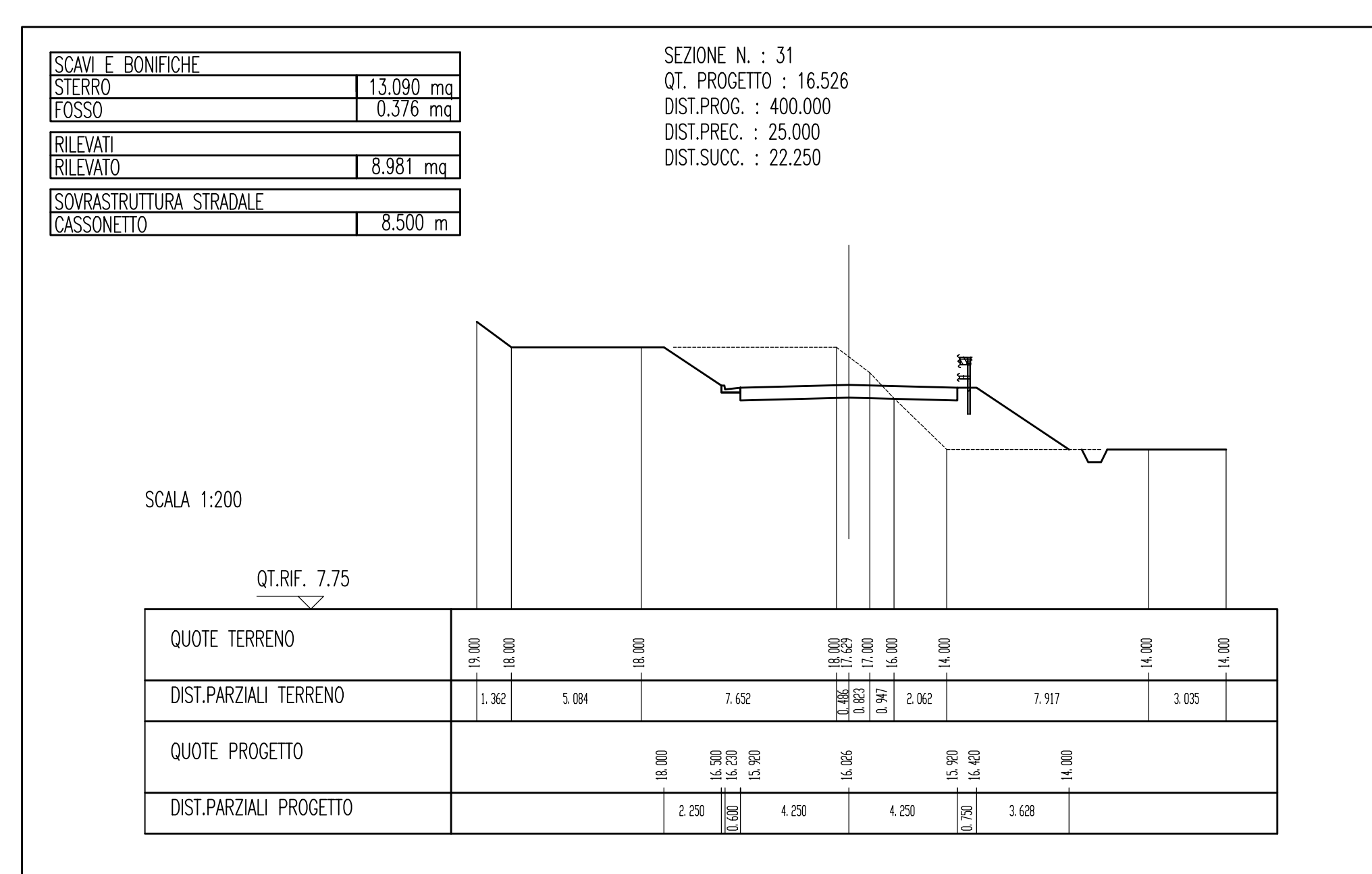
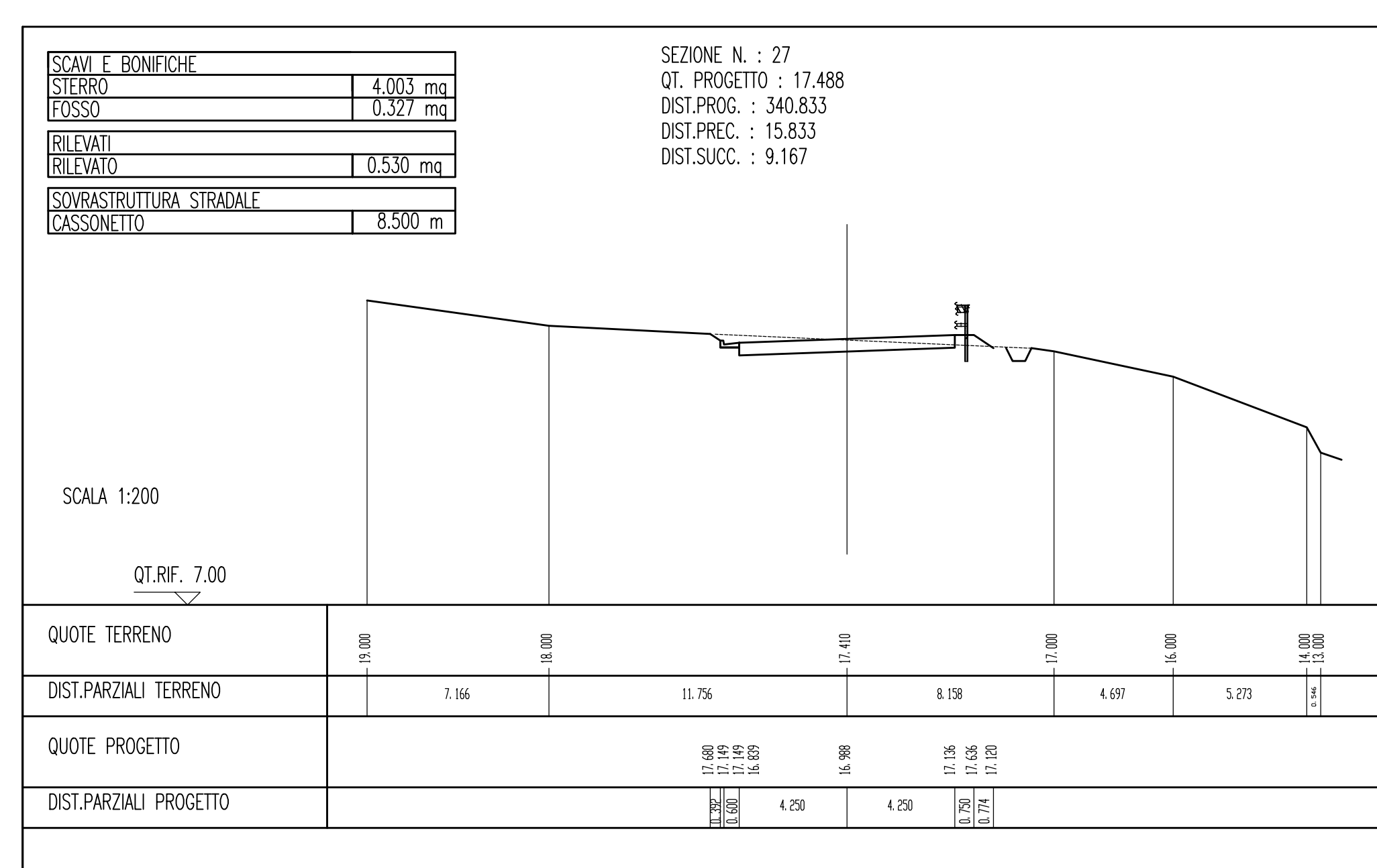
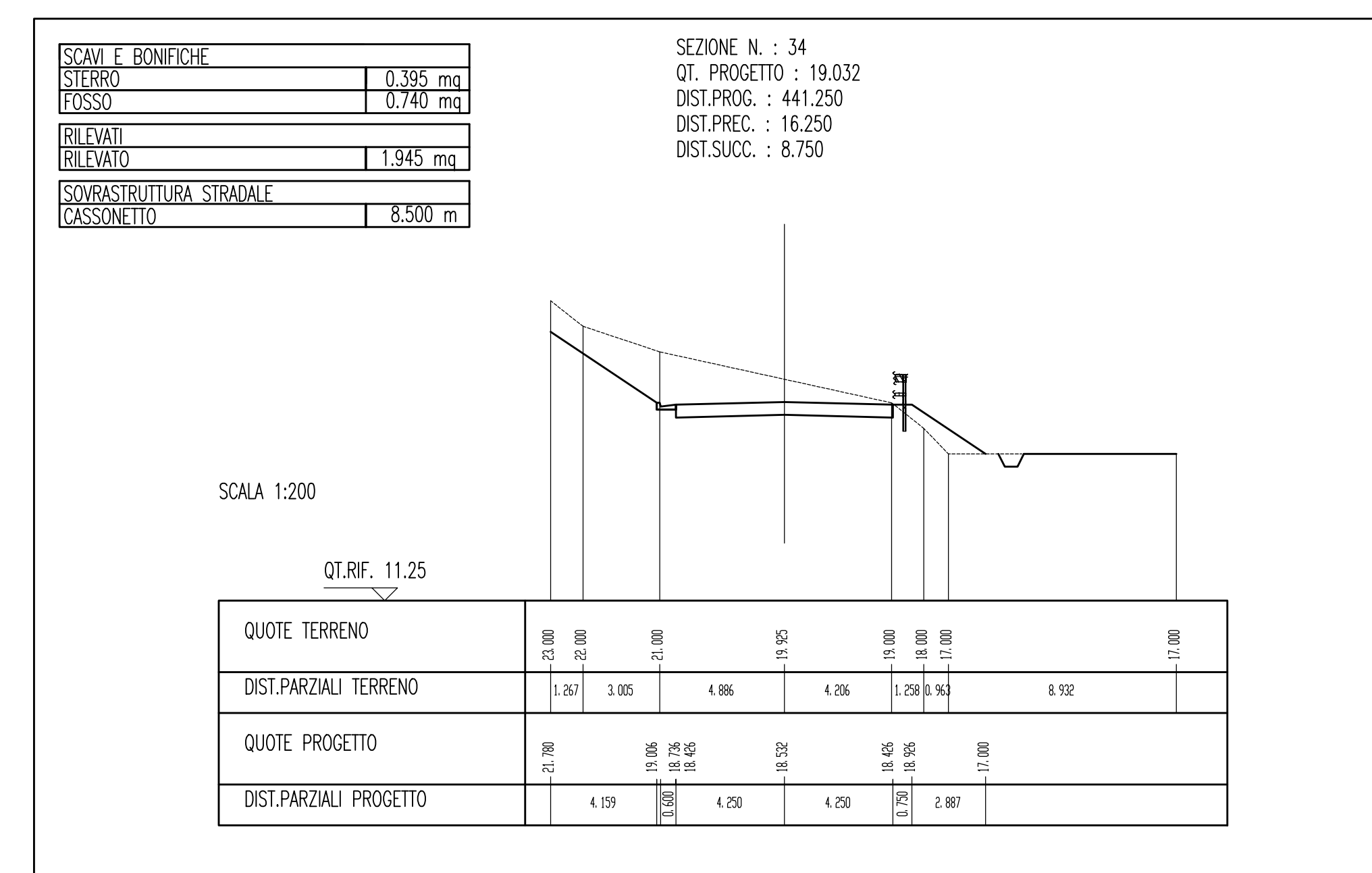
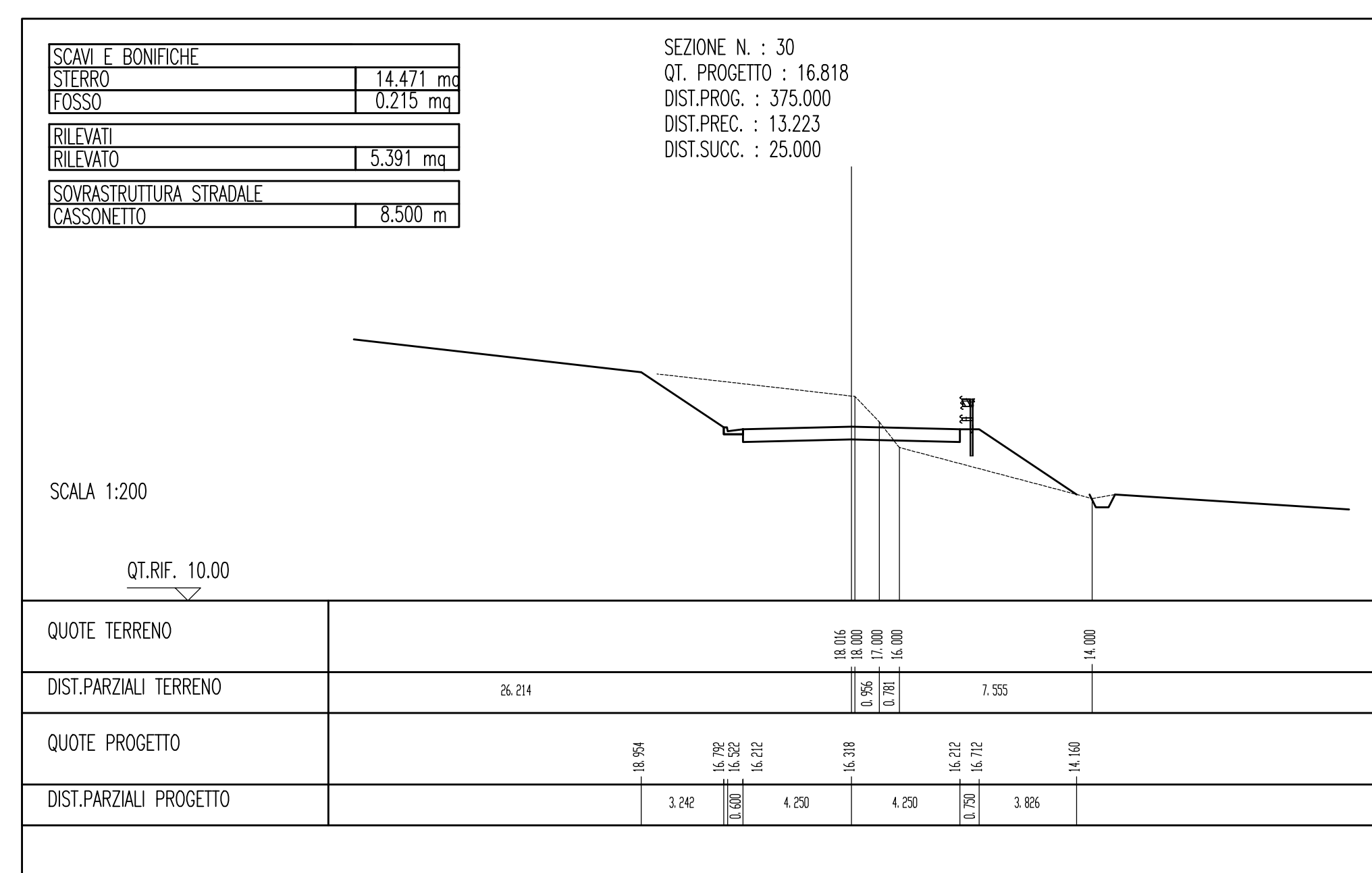
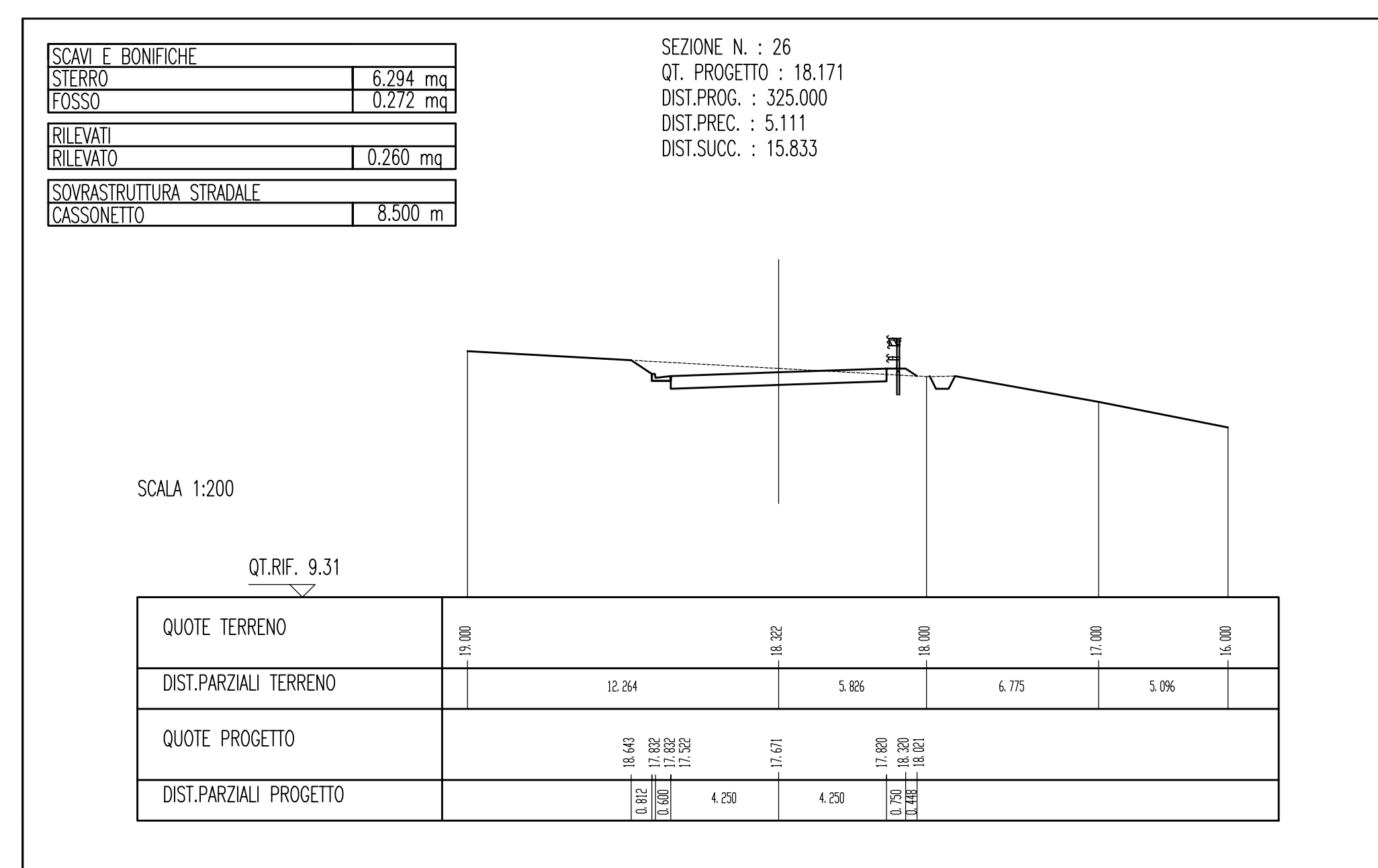
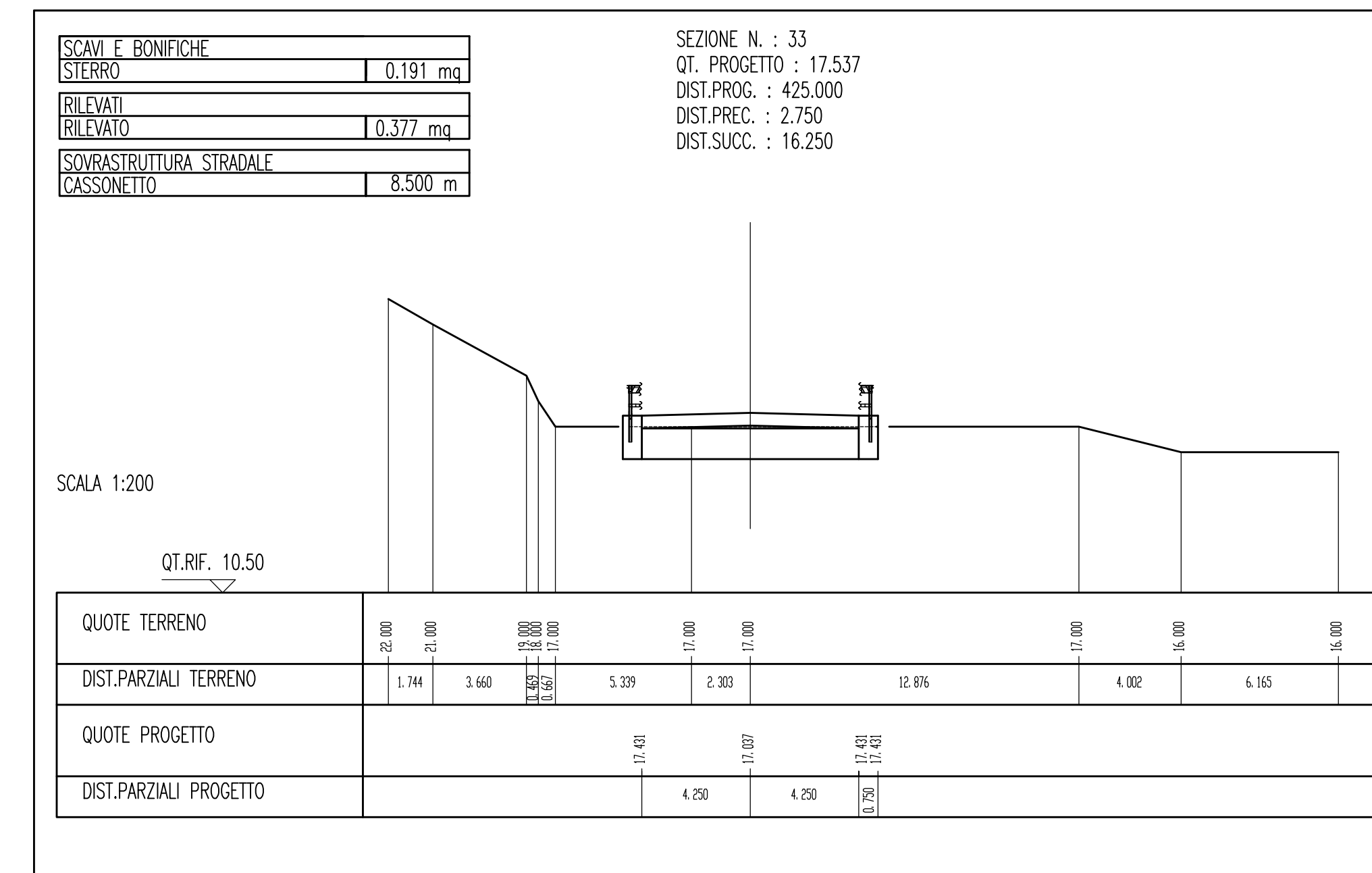
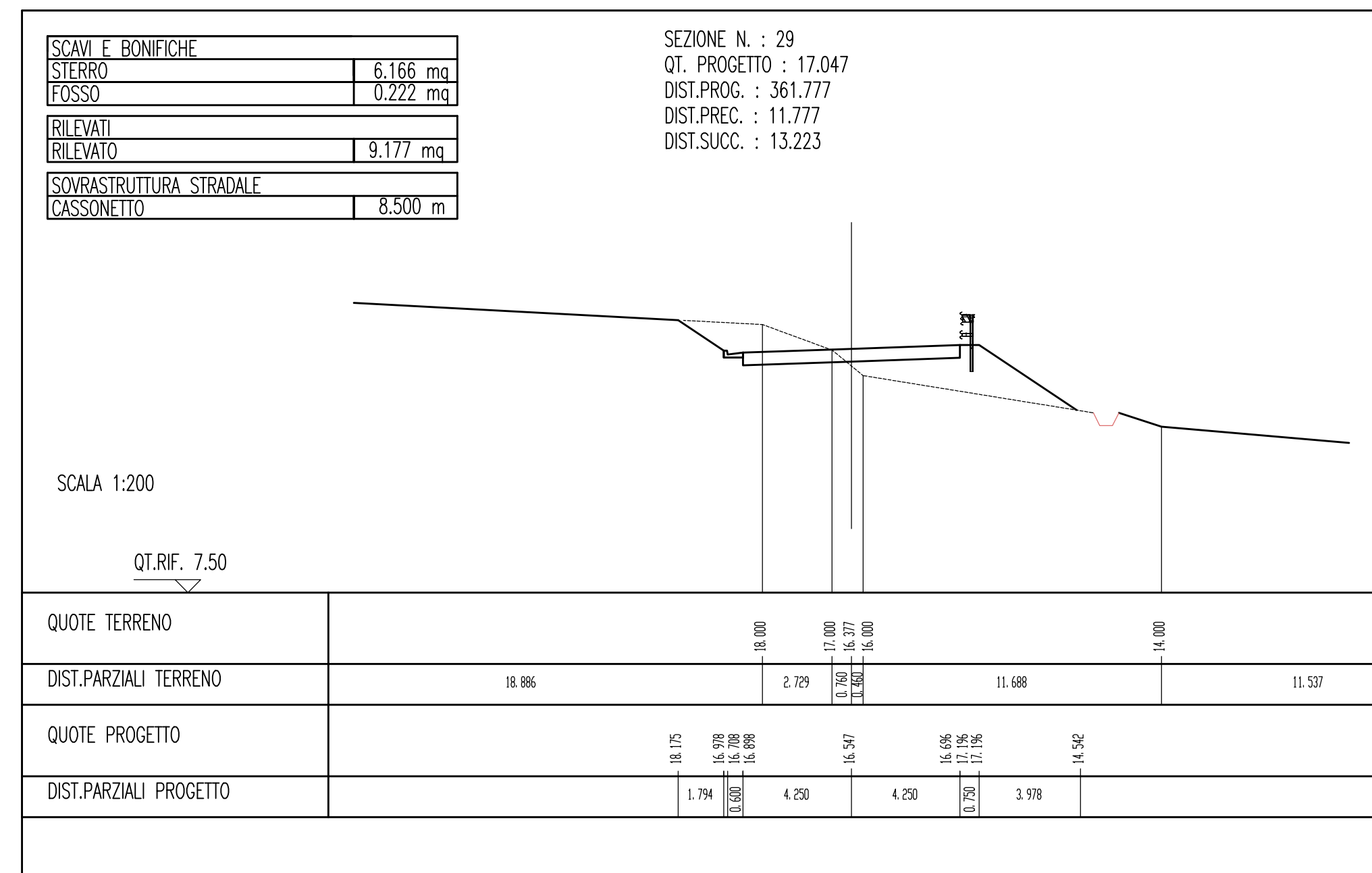
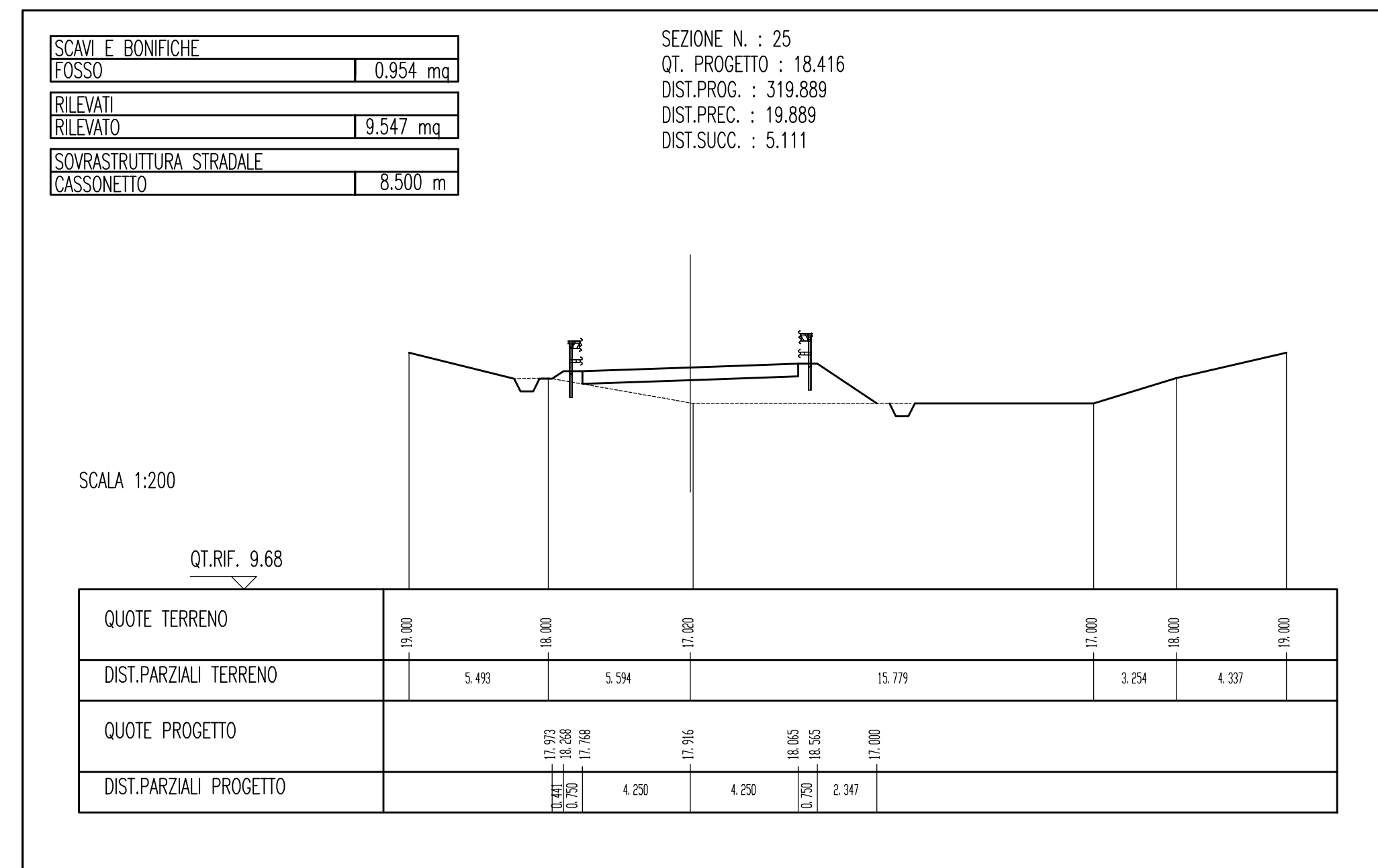

Stretto di Messina
Concessione per la progettazione, realizzazione e gestione del collegamento stabile tra lo Stretto e il Cardine
Organo di Diritto pubblico
(Legge n° 1158 del 17 dicembre 1971, modificata dal D.Lgs. n° 114 del 24 aprile 2003)

PONTE SULLO STRETTO DI MESSINA

PROGETTO DEFINITIVO

EUROLINK S.C.p.A.
IMPREGLIO S.p.A. (Mandataria)
SOCIETA' ITALIANA PER CONDOTTE D'ACQUA S.p.A. (Mandante)
COOPERATIVA MURATORI E CEMENTISTI - C.M.C. di Ravenna Soc. Coop. a.r.l. (Mandante)
SACYR S.A.U. (Mandante)
ISHIKAWAJIMA - HARIMA HEAVY INDUSTRIES CO. Ltd. (Mandante)
A.C.I. S.C.P.A. - CONSORZIO STABILE (Mandante)

<p>IL PROGETTISTA Ing. F. Cavallaro Ordine Ingegneri Messina n° 1110</p>	<p>IL CONTRAENTE GENERALE Project Manager (Ing. P.P. Marcheselli)</p>	<p>STRETTO DI MESSINA Direttore Generale e RUP Validazione (Ing. G. Timmenhri)</p>	<p>STRETTO DI MESSINA Amministratore Delegato (Dott. P. Gucci)</p>
--	---	--	--

COLLEGAMENTI VERSANTE SICILIA CZ0517_F0

CANTIERI
ITINERARI
NUOVI ITINERARI - NI.82
P-SN8 - SEZIONI TRASVERSALI TRATTO 3 - TAV 3/6

REV.	DATA	DESCRIZIONE	REDATTO	VERIFICATO	APPROVATO
FO	20-06-2011	EMISSIONE FINALE	CHIOVETTA	FLERES	BUIGLIO

NOME DEL FILE: CZ0517_F0.dwg