

SEZ. 2 - SCALETTA ALLA MARINARA IN ACCIAIO INOX AISI 316 L
SCALA 1:25

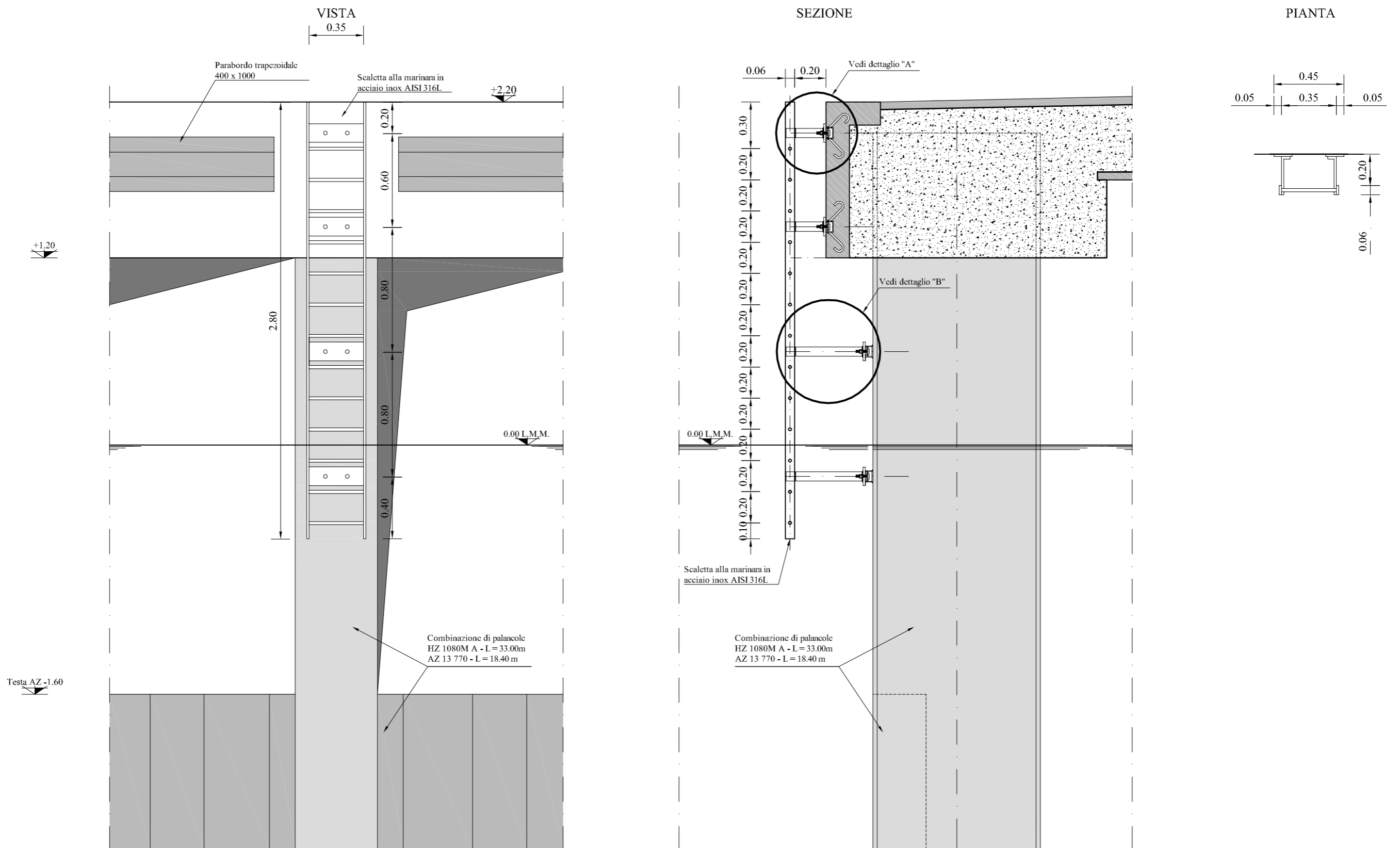

VISTA DETTAGLI "A" E "B"
SCALA 1:10

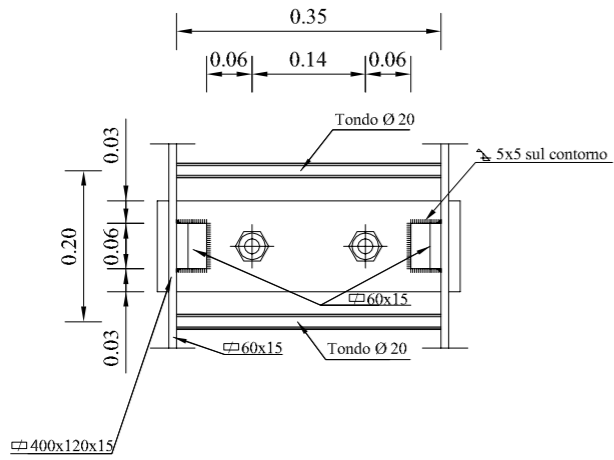

DETTAGLIO "A"
SCALA 1:10
SEZIONE

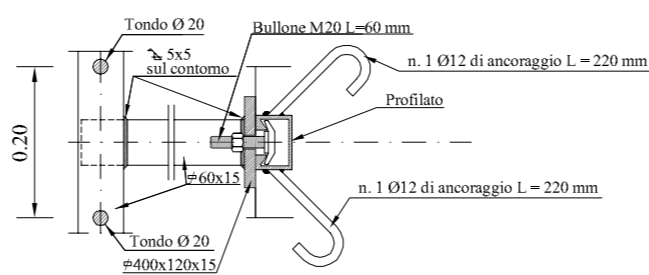

DETTAGLIO "B"
SCALA 1:10
SEZIONE

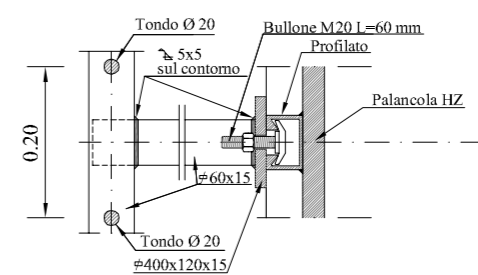

PARABORDO TRAPEZOIDALE 400 x 1000 - SCALA 1:10

Le misure sono espresse in mm.

PIANTA

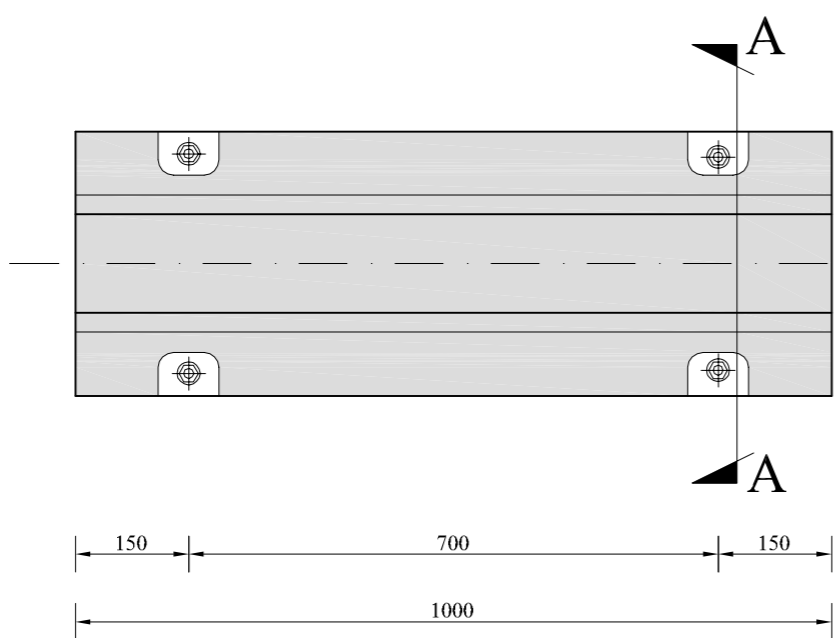

SEZIONE A - A

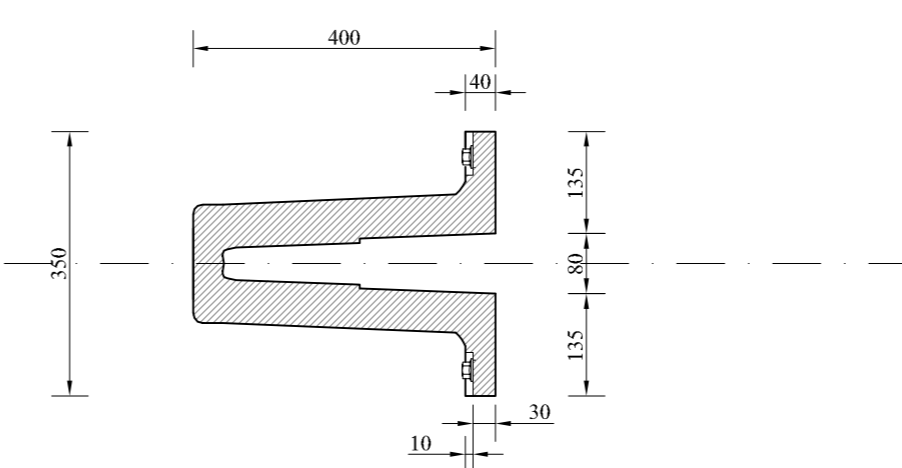

VISTA LATERALE

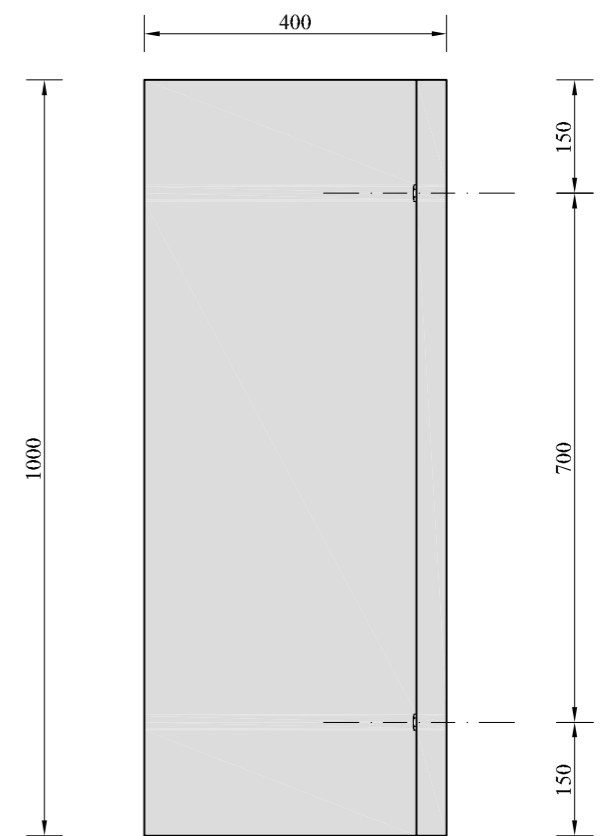

BITTA IN GHISA DA 200 kN - SCALA 1:20

VISTA LATERALE

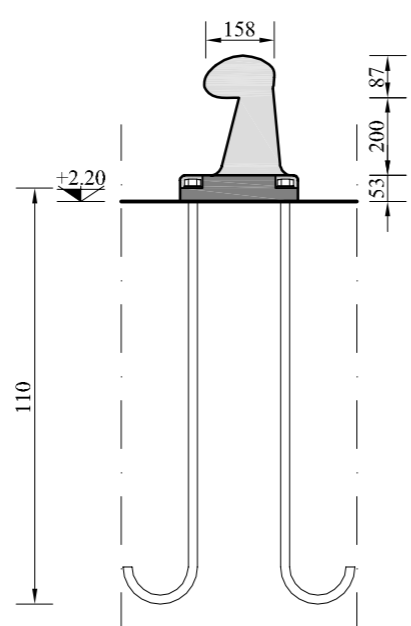

PIANTA

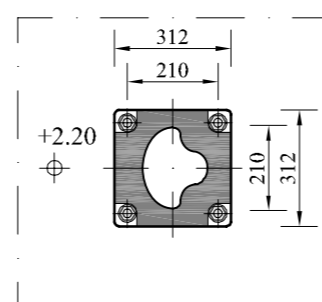

VISTA FRONTALE

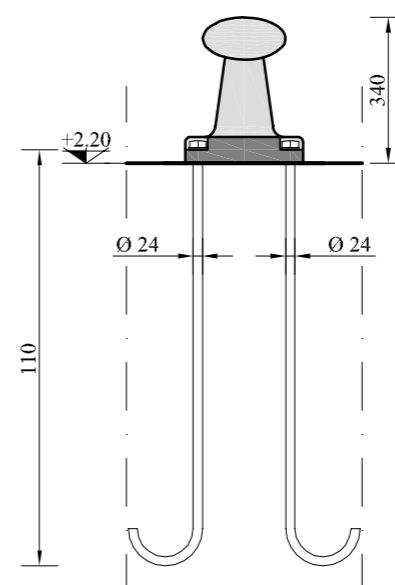

CARATTERISTICHE DELLA BITTA:

- PRODUZIONE CONFORME ALLE NORME ISO 9002
 - BITTA IN GHISA UNI 185 - ISO 1083
 - TIRANTI IN ACCIAIO ASTM A193 GR. B7
 - DADI IN ACCIAIO ASTM A 193 GR. 2H
- Le misure sono espresse in mm.

Tav. D27.4
Scala: Varia

ARREDI PORTUALI - PARTICOLARI

Data: MAGGIO 2010
SIGENCO SISTEMI GENERALI COSTRUZIONI